

H:\15158001\15860_21 2021 Road Bond Paving Project\Drawing Files\Engineering\Lathrup Base 2021.dwg

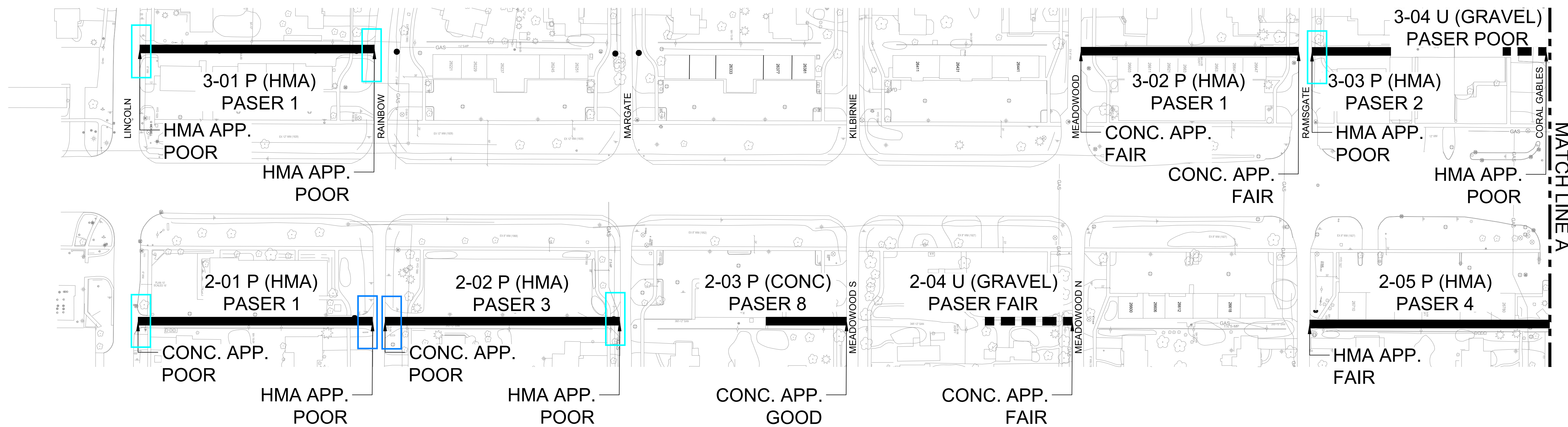

KEY: X-XX P/U

PAVED OR UNIMPROVED
ALLEY NUMBER

- 1 = NORTH OF 11 MILE AND EAST OF SOUTHFIELD
- 2 = SOUTH OF 11 MILE AND EAST OF SOUTHFIELD
- 3 = SOUTH OF 11 MILE AND WEST OF SOUTHFIELD
- 4 = NORTH OF 11 MILE AND WEST OF SOUTHFIELD

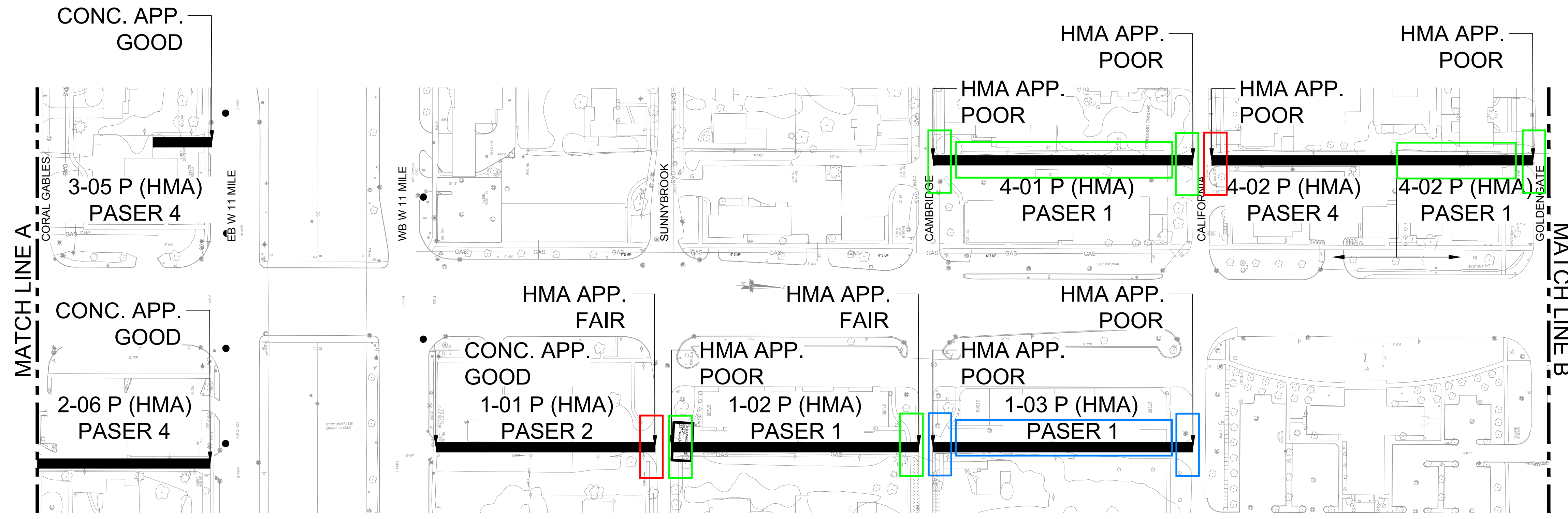
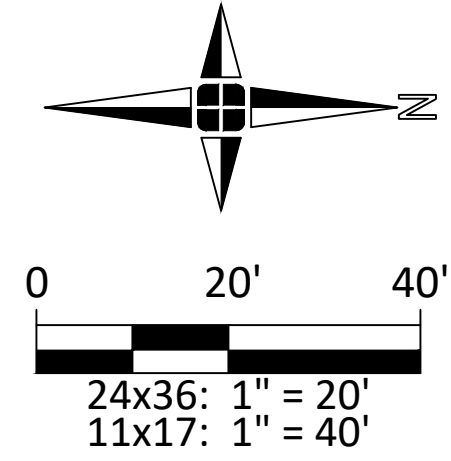

- 2021 (COMPLETED)
- 2022
- 2023
- 2024
- 2025

PROPOSED 5-YR CIP



Engineers
Surveyors
Planners
Landscape Architects

1025 East Maple Road
Suite 100
Birmingham, MI 48009
p (248) 852-3100
f (313) 962-5068
www.giffelswebster.com

Executive:	S.A.R.
Manager:	S.A.R.
Designer:	A.J.K.
Quality Control:	S.A.R.



Know what's below.
Call before you dig.

DATE:	ISSUE:

Developed For:
CITY OF LATHRUP VILLAGE
27400 SOUTHFIELD ROAD
LATHRUP VILLAGE, MI 48076
(248) 557-2600

ALLEY ASSESSEMENT (1 OF 2)

CITY OF LATHRUP VILLAGE
OAKLAND COUNTY
MICHIGAN

Date:	5.18.21
Scale:	AS SHOWN
Sheet:	1 of 2
Project:	18736.21

Copyright © 2021 Giffels Webster.
No reproduction shall be made without the prior written consent of Giffels Webster.

H:\1515800\15860\21 2021 Road Bord Paving Project\Drawing Files\Engineering\Lathrup Base 2021.dwg

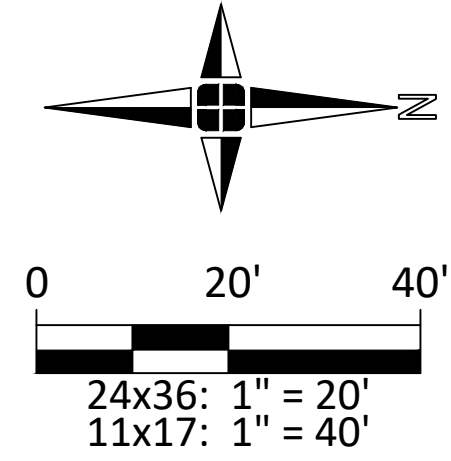
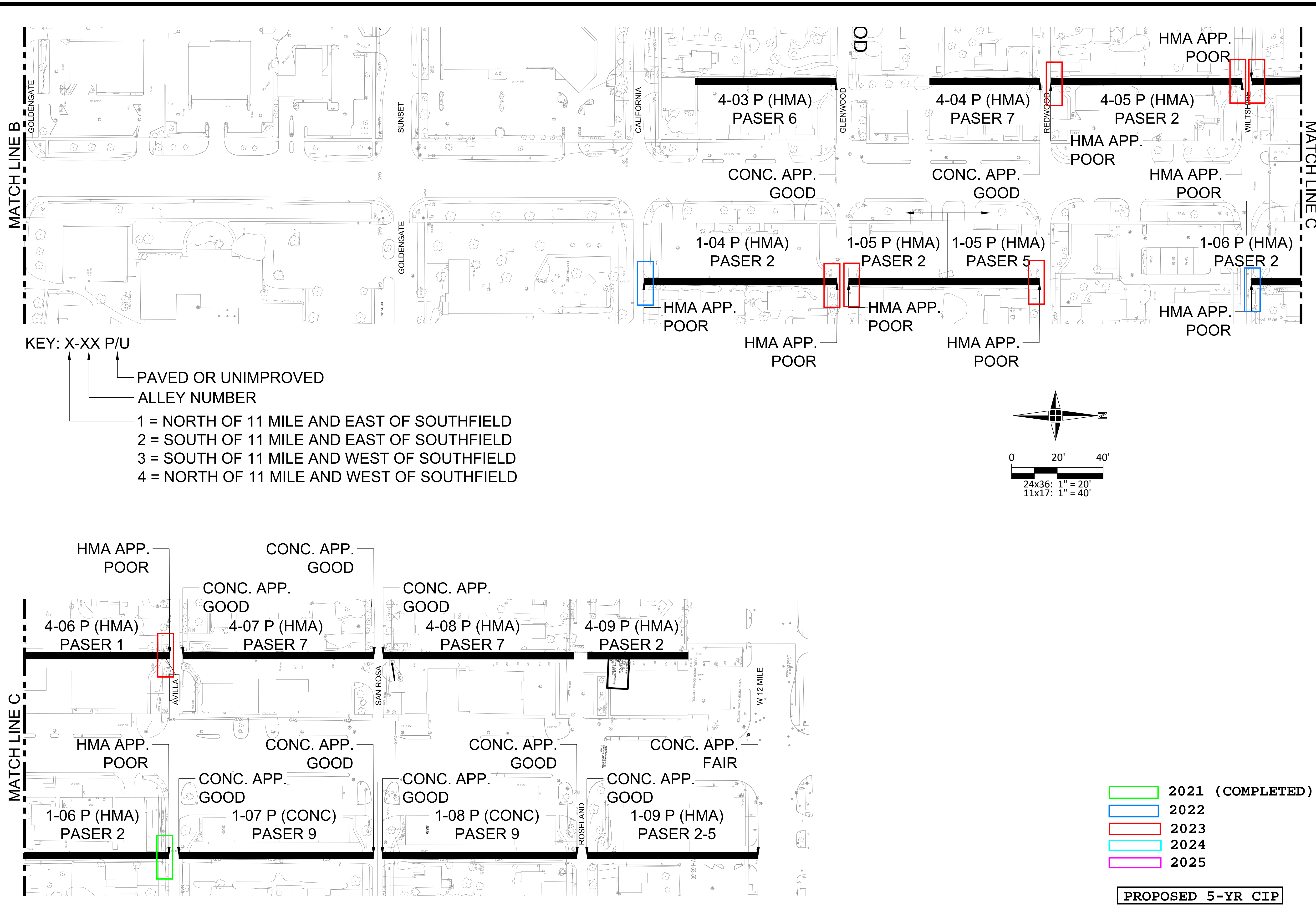

- 2021 (COMPLETED)
- 2022
- 2023
- 2024
- 2025

PROPOSED 5-YR CIP



Engineers
 Surveyors
 Planners
 Landscape Architects

1025 East Maple Road
 Suite 100
 Birmingham, MI 48009
 p (248) 852-3100
 f (313) 962-5068
 www.giffelswebster.com

Executive: S.A.R.
 Manager: S.A.R.
 Designer: A.J.K.
 Quality Control: S.A.R.



Know what's below.
 Call before you dig.

DATE:	ISSUE:

Developed For:
CITY OF LATHRUP VILLAGE
 27400 SOUTHFIELD ROAD
 LATHRUP VILLAGE, MI 48076
 (248) 557-2600

ALLEY ASSESSMENT (2 OF 2)

CITY OF LATHRUP VILLAGE
 OAKLAND COUNTY
 MICHIGAN

Date: 5.18.21
 Scale: AS SHOWN
 Sheet: 2 of 2
 Project: 18736.21
 Copyright © 2021 Giffels Webster.
 No reproduction shall be made without the prior written consent of Giffels Webster.