

# VILLAGE CIRCLE-VILLAGE SOLARS PDA - PHASE VII

## 1067 WARREN ROAD

### LANSING (T), NEW YORK

#### PLANNING/ZONING DATA - PHASE VII

SITE ZONING:	R-2 WITH 572 UNIT PDA
SITE AREA:	5.31 ACRES
PROP. IMPERMEABLE:	2.55 ACRES
PROP. OPEN SPACE:	2.76 ACRES
% OPEN SPACE:	52%
PROP. # OF UNITS:	138
PROPOSED PARKING SPACES	205
PARKING SPACES/UNIT	1.5

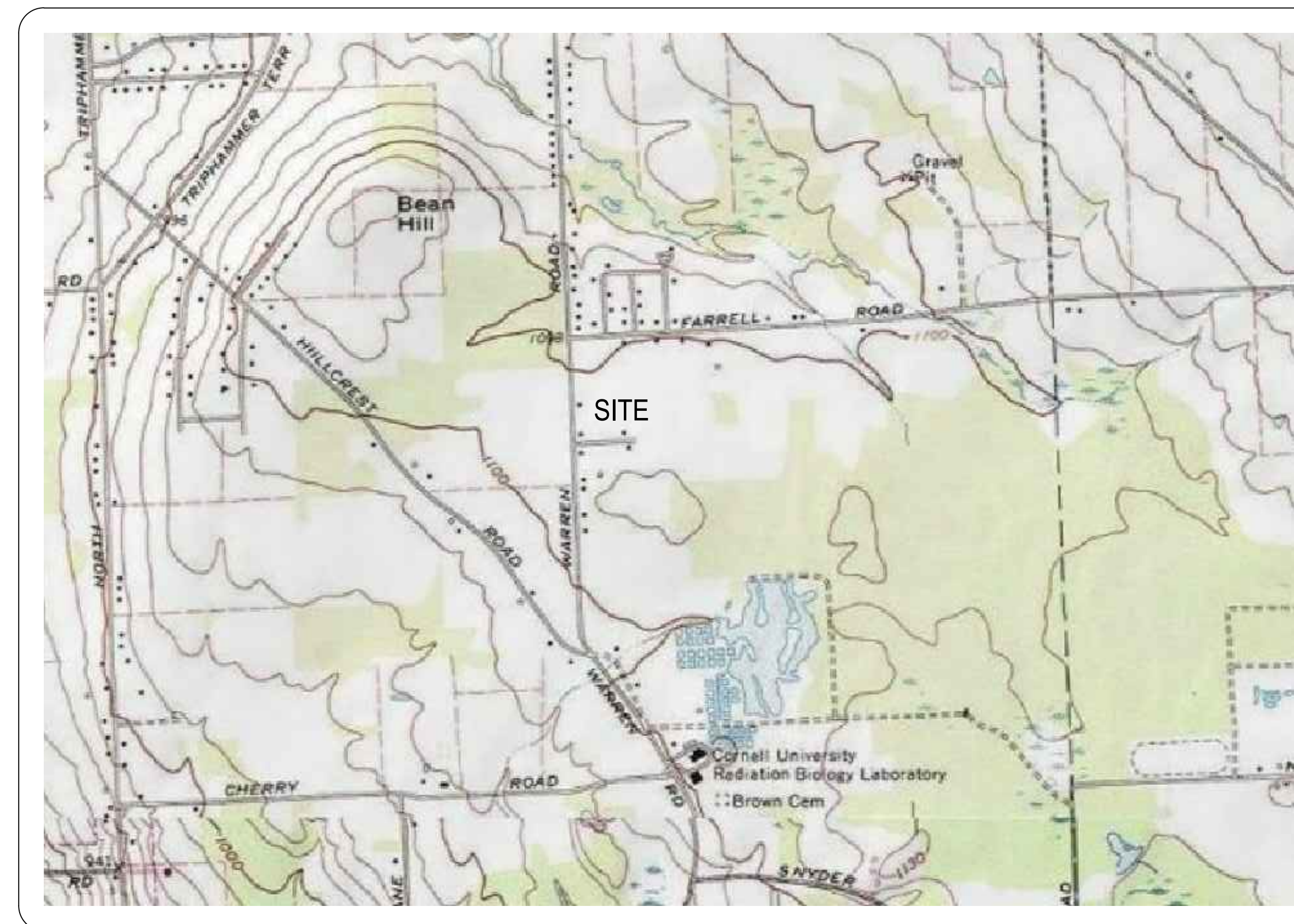

• LOCATION MAP •

N.T.S.

#### INDEX OF DRAWINGS

COVER SHEET	
ST-1	EXISTING SITE PLAN
ST-2 & 2A	PROPOSED SITE PLAN
ST-2B	PROPOSED SITE PLAN - 30 SCALE
ST-3	E&SC PLAN
ST-4	E&SC DETAILS
ST-5	BIORETENTION AREA DETAILS
ST-6 A & 6B	POND 1 & 4 DETAILS
ST-7	HYDROLOGIC & HYDRAULIC RUNOFF EXISTING
ST-8	HYDROLOGIC & HYDRAULIC RUNOFF - PROP 1
ST-9	HYDROLOGIC & HYDRAULIC RUNOFF - PROP 2
ST-10	TYP BUILDING EXTERIOR LIGHTING
ST-11	FITNESS TRAIL AND DUMPSTER LOCATIONS
ST-12	PLANTING PLAN

#### PREPARED FOR:

LUCENTE HOLDINGS, LLC.  
1067 WARREN ROAD, SUITE B  
LANSING, NY 14882

DATE: SEPTEMBER 6, 2022

#### PREPARED BY:

TIMOTHY C. BUHL P.E.  
35 FIRE LANE 24  
AUBURN, NY 13021











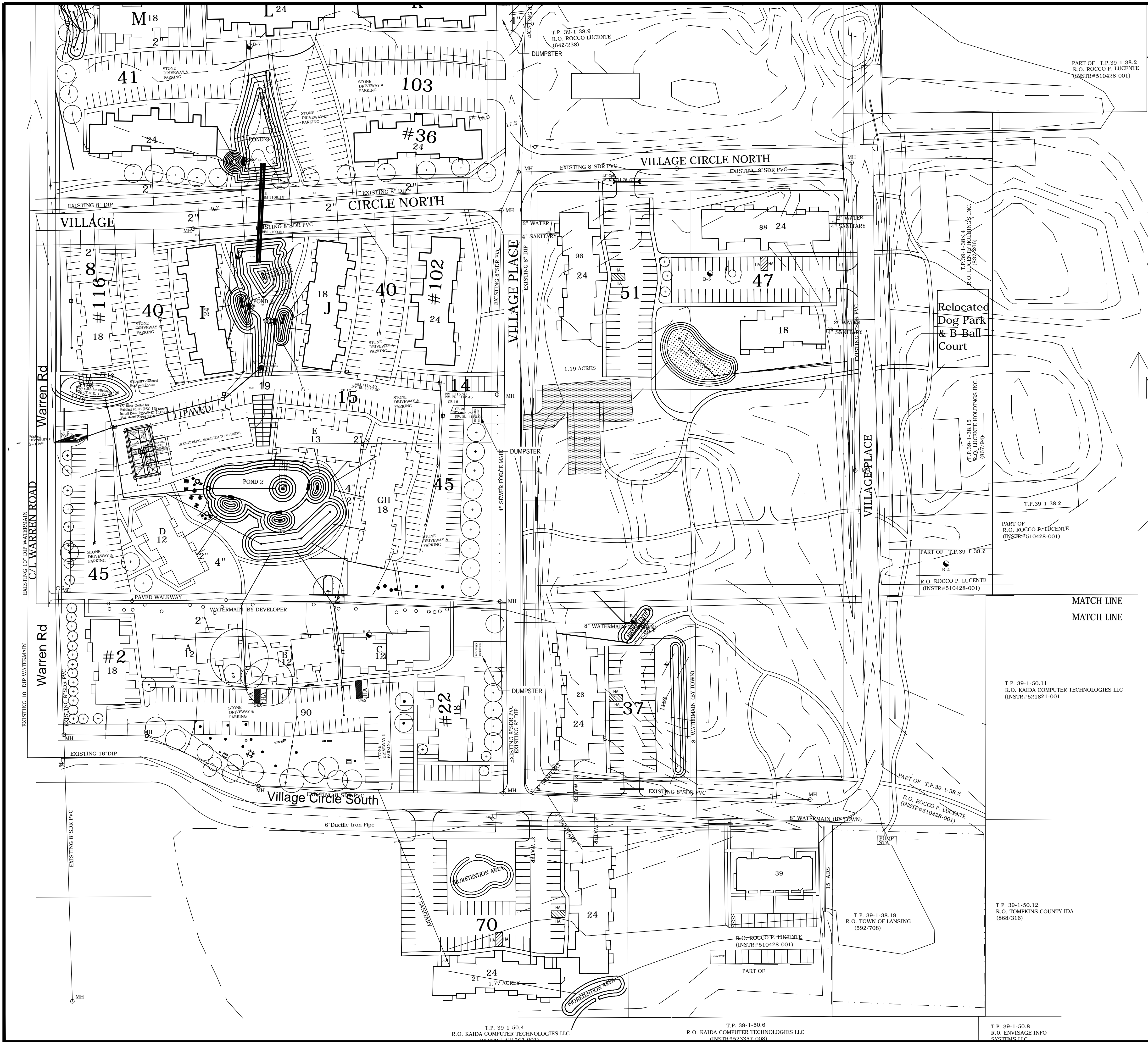

**NOTES (BLDG & PARKING)**

1. PUBLIC SEWER AND WATER MAINS ARE ALL EXISTING. SEE SHEET 2-A
2. WATER SERVICES AND SEWER LATERALS TO EACH PROPOSED BUILDING ARE NEW.
3. HANDICAPPED ACCESSIBLE PARKING INDICATED AS HA
4. NUMBERS INSIDE NEW BUILDINGS REPRESENT THE # OF DWELLINGS CONTAINED
5. BOLD NUMBERS IN PARKING AREAS REPRESENT THE NUMBER OF SPACES PROVIDED (205 TOTAL)

No.	Date	SYMBOL	DESCRIPTION

**PROPOSED SITE PLAN**  
 LUCENTE HOLDINGS, INC  
 381 HAGADORN HILL RD.  
 SPENCER, NY 14883

VILLAGE CIRCLE - PHASE 7  
 LUCENTE HOMES/VILLAGE SOLARS  
 LANSING (T) TOMPKINS CO. N.Y.

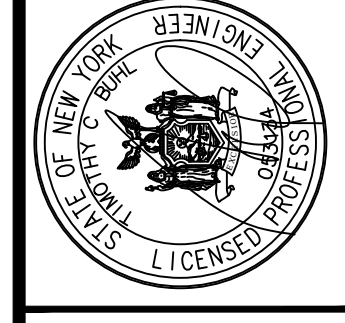

**TIMOTHY C. BUHL, P.E.**  
 35 FIRE LANE 24, AUBURN, NY 13021

DATE: Sept. 6, 2022  
 SCALE: 1" = 60'  
 DRAWN: SDG  
 JOB:  
 SHEET:











## GENERAL NOTES

NYS STANDARDS AND SPECIFICATIONS FOR EROSION AND SEDIMENT CONTROL, NOVEMBER 2016

1. PHYSICALLY MARK LIMITS OF LAND DISTURBANCE ON THE SITE WITH TAPE, SIGNS, OR ORANGE CONSTRUCTION FENCE, SO THAT WORKERS CAN SEE THE AREAS TO BE PROTECTED.

2. DIVERT OFF-SITE RUNOFF FROM HIGHLY ERODIBLE SOILS AND STEEP SLOPES TO STABLE AREAS.

3. CLEAR ONLY WHAT IS REQUIRED FOR IMMEDIATE CONSTRUCTION ACTIVITY. LARGE PROJECTS SHOULD BE CLEARED AND GRADED AS CONSTRUCTION PROGRESSES. AREAS EXCEEDING TWO ACRES IN SIZE SHOULD NOT BE DISTURBED WITHOUT A SEQUENCING PLAN THAT REQUIRES PRACTICES TO BE INSTALLED AND THE SOIL STABILIZED, AS DISTURBANCE BEYOND THE TWO ACRES CONTINUES. MASS CLEARINGS AND GRADING OF ENTIRE SITE SHOULD BE AVOIDED.

4. RE-STABILIZE DISTURBED AREAS AS SOON AS POSSIBLE AFTER CONSTRUCTION IS COMPLETED. ON SITES GREATER THAN TWO ACRES IN SIZE, WAITING UNTIL ALL DISTURBED AREAS ARE READY FOR SEEDING IS UNACCEPTABLE. FOURTEEN DAYS SHALL BE THE MAXIMUM EXPOSURE PERIOD. MAINTENANCE MUST BE PERFORMED AS NECESSARY TO ENSURE CONTINUED STABILIZATION. EXCEPT AS NOTED BELOW, ALL SITES SHALL BE SEEDED AND STABILIZED WITH EROSION CONTROL MATERIALS, SUCH AS STRAW MULCH, JUTE MESH, OR EXCELSIOR, INCLUDING AREAS WHERE CONSTRUCTION HAS BEEN SUSPENDED OR SECTIONS COMPLETED:

A. FOR ACTIVE CONSTRUCTION AREAS SUCH AS BORROW OR STOCKPILE AREAS, ROADWAY IMPROVEMENTS AND AREAS WITHIN 50 FT. OF A BUILDING UNDER CONSTRUCTION, A PERIMETER SEDIMENT CONTROL SYSTEM CONSISTING, FOR EXAMPLE, SILT FENCING, SHALL BE INSTALLED AND MAINTAINED TO CONTAIN SOIL. EXPOSED DISTURBED AREAS ADJACENT TO A CONVEYANCE THAT PROVIDES RAPID OFF-SITE DISCHARGE OF SEDIMENT, SUCH AS A CUT SLOPE AT AN ENTRANCE, SHALL BE COVERED WITH PLASTIC OR GEOTEXTILE FABRIC TO PREVENT SOIL LOSS UNTIL IT CAN BE STABILIZED. STABILIZED CONSTRUCTION ENTRANCES WILL BE MAINTAINED TO CONTROL VEHICLE TRACKING MATERIAL OFF-SITE.

B. ON THE CUT SIDE OF ROADS, DITCHES SHALL BE STABILIZED IMMEDIATELY WITH ROCK RIP-RAP OR OTHER NON-ERODIBLE LINERS (E.G. ROLLED EROSION PRODUCTS), OR WHERE APPROPRIATE, VEGETATIVE MEASURES SUCH AS SOD.

C. PERMANENT SEEDING SHOULD OPTIMALLY BE UNDERTAKEN IN THE SPRING FROM MARCH THROUGH MAY, AND IN LATE SUMMER AND EARLY FALL FROM SEPTEMBER THROUGH OCTOBER 15. DURING THE PEAK SUMMER MONTHS AND IN THE FALL AFTER OCTOBER 15, WHEN SEEDING IS FOUND TO BE IMPRACTICABLE, AN APPROPRIATE TEMPORARY MULCH SHALL BE APPLIED. PERMANENT SEEDING MAY BE UNDERTAKEN DURING THE SUMMER IF PLANS PROVIDE FOR ADEQUATE WATERING. TEMPORARY SEEDING WITH RYE CAN BE UTILIZED THROUGH NOVEMBER.

D. ALL SLOPES STEEPER THAN 3:1 (H:V), OR 33.3%, AS WELL AS PERIMETER DIKES, SEDIMENT BASINS AND TRAPS, AND EMBANKMENTS SHALL, UPON COMPLETION, BE IMMEDIATELY STABILIZED WITH SOD, SEED AND ANCHORED STRAW MULCH, OR OTHER APPROVED STABILIZATION MEASURES. AREAS OUTSIDE OF THE PERIMETER SEDIMENT CONTROL SYSTEM SHALL NOT BE DISTURBED. MAINTENANCE SHALL BE PERFORMED AS NECESSARY TO ENSURE CONTINUED STABILIZATION.

E. TEMPORARY SEDIMENT TRAPPING DEVICES SHALL NOT BE REMOVED UNTIL PERMANENT STABILIZATION IS ESTABLISHED IN ALL CONTRIBUTORY DRAINAGE AREAS. SIMILARLY, STABILIZATION SHALL BE ESTABLISHED PRIOR TO CONVERTING SEDIMENT TRAPS/BASINS INTO PERMANENT (POST-CONSTRUCTION) STORMWATER MANAGEMENT PRACTICES.

5. IF TEMPORARY WORK ROADS OR HAUL ROADS CROSS STREAM CHANNELS, ADEQUATE WATERWAY OPENINGS SHALL BE CONSTRUCTED USING SPANS, CULVERTS, WASHED ROCK BACKFILL, OR OTHER ACCEPTABLE, CLEAN METHODS THAT WILL ENSURE THAT ROAD CONSTRUCTION AND THEIR USE DO NOT RESULT IN TURBIDITY AND SEDIMENT DOWNSTREAM. ALL CROSSING ACTIVITIES AND APPURTENANCES ON STREAMS REGULATED BY ARTICLE 15 OF THE ENVIRONMENTAL CONSERVATION LAW SHALL BE IN COMPLIANCE WITH A PERMIT ISSUED PURSUANT TO ARTICLE 15 OF THE ECL.

6. MAKE SURE THAT ALL CONTRACTORS AND SUB-CONTRACTORS UNDERSTAND THE ESC PLAN AND SIGN THE CERTIFICATION STATEMENT REQUIRED BY NYSDEC GP.

7. DESIGNATE RESPONSIBILITY FOR THE ESC PLAN TO ONE INDIVIDUAL. THIS PERSON SHALL BE NAMED IN THE NOTICE OF INTENT.

8. AN ESC PLAN INSPECTION PROGRAM MEETING THE REQUIREMENTS OF THE NYSDEC GP, IS NECESSARY TO DETERMINE WHEN ESC MEASURES NEED MAINTENANCE OR REPAIR. PAY PARTICULAR ATTENTION TO INSPECTIONS REQUIRED AFTER RAINFALL. THE INSPECTION PROGRAM SHALL ALSO STATE THE COMPLETION OF IDENTIFIED REPAIR AND MAINTENANCE ITEMS.

9. IF CONSTRUCTION ACTIVITIES CONTINUE DURING WINTER, ACCESS POINTS SHOULD BE ENLARGED AND STABILIZED TO PROVIDE FOR SNOW STOCKPILING. IN ADDITION SNOW MANAGEMENT PLAN SHOULD BE PREPARED WITH ADEQUATE STORAGE AND CONTROL OF MELTWATER. A MINIMUM 25 FOOT BUFFER SHALL BE MAINTAINED FROM PERIMETER CONTROLS SUCH AS SILT FENCING. KEEP DRAINAGE STRUCTURES OPEN AND FREE OF SNOW AND ICE DAMS. INSPECTION AND MAINTENANCE ARE NECESSARY TO ENSURE THE FUNCTION OF THESE PRACTICES DURING RUNOFF EVENTS.

## LAND GRADING SPECIFICATIONS

1. ALL FILLS SHALL BE COMPACTED AS REQUIRED TO REDUCE EROSION, SLIPPAGE, SETTLEMENT, SUBSIDENCE OR OTHER RELATED PROBLEMS. FILL INTENDED TO SUPPORT BUILDINGS, STRUCTURES AND CONDUITS, ETC. SHALL BE COMPACTED IN ACCORDANCE WITH LOCAL REQUIREMENTS OR CODES.

2. ALL FILL TO BE PLACED AND COMPACTED IN LAYERS NOT TO EXCEED 9 INCHES IN THICKNESS.

3. FILL MATERIAL SHALL BE FREE OF FROZEN PARTICLES, BRUSH, ROOTS, SOD, OR OTHER FOREIGN OR OTHER OBJECTIONABLE MATERIALS THAT WOULD INTERFERE WITH OR PREVENT CONSTRUCTION OF SATISFACTORY FILLS.

4. SEEPS OR SPRINGS ENCOUNTERED DURING CONSTRUCTION SHALL BE HANDLED IN ACCORDANCE WITH THE STANDARD AND SPECIFICATION FOR SUBSURFACE DRAIN OR OTHER APPROVED METHOD.

5. STOCKPILES, BORROW AREAS AND SPOIL AREAS SHALL BE SHOWN ON THE PLANS AND SHALL BE SUBJECT TO THE PROVISIONS OF THIS STANDARD AND SPECIFICATION.

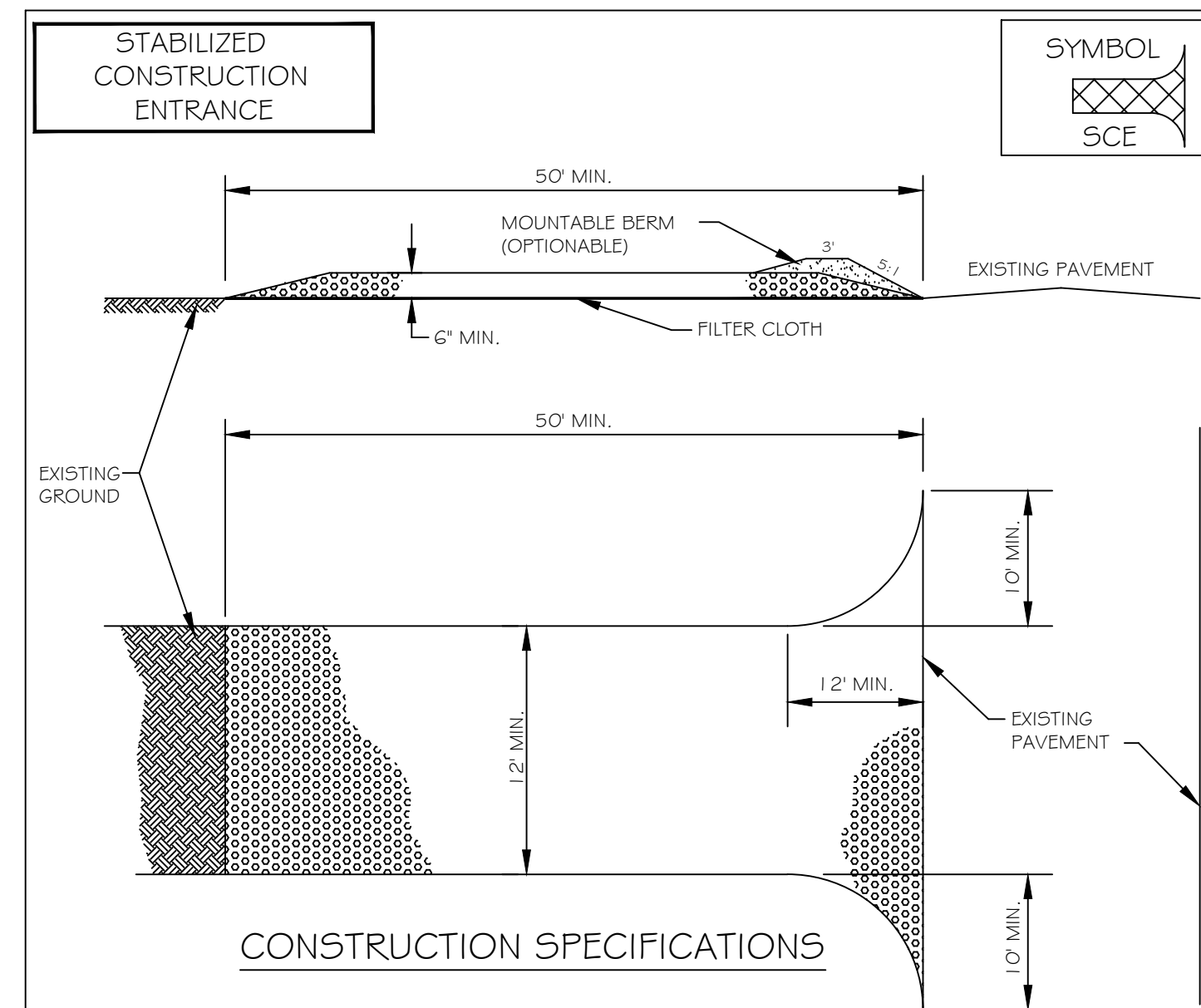

## CONSTRUCTION SPECIFICATIONS

1. STONE SIZE - USE 2" STONE OR RECLAIMED OR RECYCLED CONCRETE EQUIVALENT.
2. LENGTH - NOT LESS THAN 50 FEET (EXCEPT ON A SINGLE RESIDENCE LOT WHERE A 30 FOOT MIN. LENGTH WOULD APPLY).
3. THICKNESS - NOT LESS THAN SIX (6) INCHES.
4. WIDTH - TWELVE (12) FOOT MIN. BUT NOT LESS THAN THE FULL WIDTH AT POINTS WHERE INGRESS OR EGRESS OCCURS, TWENTY-FOUR (24) FOOT IF SINGLE ENTRANCE TO SITE.
5. FILTER CLOTH - WILL BE PLACED OVER THE ENTIRE AREA PRIOR TO PLACING OF STONE.
6. SURFACE WATER - ALL SURFACE WATER FLOWING OR DIVERTED TOWARD CONSTRUCTION ENTRANCES SHALL BE PIPED ACROSS THE ENTRANCE. IF PIPING IS IMPRACTICAL, A MOUNTABLE BERM WITH 5:1 SLOPES WILL BE PERMITTED.
7. MAINTENANCE - THE ENTRANCE SHALL BE MAINTAINED IN A CONDITION WHICH WILL PREVENT TRICKLING OR FLOWING OF SEDIMENT ONTO PUBLIC RIGHTS-OF-WAY. ALL SEDIMENT SPILLED, DROPPED, WASHED OR TRACED ONTO PUBLIC RIGHTS-OF-WAY MUST BE REMOVED IMMEDIATELY.
8. WHEN WASHING IS REQUIRED, IT SHALL BE DONE ON AN AREA STABILIZED WITH STONE AND WHICH DRAINS INTO AN APPROVED SEDIMENT TRAPPINGS DEVICE.
9. PERIODIC INSPECTION AND NEEDED MAINTENANCE SHALL BE PROVIDED AFTER EACH RAIN.
10. TEMPORARY CONSTRUCTION ENTRANCES, EXITS AND TEMPORARY ACCESS SHALL BE SUBJECT TO THE APPROVAL OF THE APPROPRIATE AUTHORITIES.

## TOP SOILING SPECIFICATIONS

1. PRESERVE EXISTING TOPSOIL IN PLACE WHERE POSSIBLE, THEREBY REDUCING THE NEED FOR ADDED TOPSOIL.
2. AS NEEDED, INSTALL EROSION CONTROL PRACTICES SUCH AS DIVERSIONS, CHANNELS, SEDIMENT TRAPS, AND STABILIZING MEASURES, OR MAINTAIN IF ALREADY INSTALLED.
3. COMPLETE ROUGH GRADING AND FINAL GRADE, ALLOWING FOR DEPTH OF TOPSOIL TO BE ADDED.
4. SCARIFY ALL COMPACT, SLOWLY PERMEABLE, MEDIUM AND FINE TEXTURED SUBSOIL AREAS. SCARIFY AT APPROXIMATELY RIGHT ANGLES TO THE SLOPE DIRECTION IN SOIL AREAS THAT ARE STEEPER THAN 5%. AREAS THAT HAVE BEEN OVERLY COMPACTED SHALL BE DECOMPACTED TO A MINIMUM DEPTH OF 12-INCHES WITH A DEEP RIPPER OR CHISEL FLOW PRIOR TO TOPSOILING.
5. REMOVE REFUSE, WOODY PLANT PARTS, STONES OVER 3-INCHES IN DIAMETER, AND OTHER LITTER.
6. TOPSOIL SHALL HAVE AT LEAST 6% BY WEIGHT OF FINE TEXTURED STABLE ORGANIC MATERIAL, AND NO GREATER THAN 20%. MUCK SOIL SHALL NOT BE CONSIDERED TOPSOIL.
7. TOPSOIL SHALL HAVE NOT LESS THAN 20% FINE TEXTURED MATERIAL (PASSING THE NO. 200 SIEVE) AND NOT MORE THAN 15% CLAY.
8. TOPSOIL TREATED WITH SOIL STERILANTS OR HERBICIDES SHALL BE SO IDENTIFIED TO THE PURCHASER.
9. TOPSOIL SHALL BE RELATIVELY FREE OF STONES OVER 1 1/2-INCHES IN DIAMETER, TRASH, NOXIOUS WEEDS SUCH AS NUT SEDGE AND QUACKGRASS, AND WILL HAVE LESS THAN 10% GRAVEL.
10. TOPSOIL CONTAINING SOLUBLE SALTS GREATER THAN 500 PARTS PER MILLION SHALL NOT BE USED.
11. TOPSOIL SHALL BE DISTRIBUTED TO A UNIFORM DEPTH OVER THE AREA. IT SHALL NOT BE PLACED WHEN IT IS PARTIALLY FROZEN, MUDDY, OR ON FROZEN SLOPES OR OVER ICE, SNOW, OR STANDING WATER PUDDLES.
12. TOPSOIL PLACED AND GRADED ON SLOPES STEEPER THAN 5% SHALL BE PROMPTLY FERTILIZED, SEEDED, MULCHED, AND STABILIZED BY "TRACKING" WITH SUITABLE EQUIPMENT.

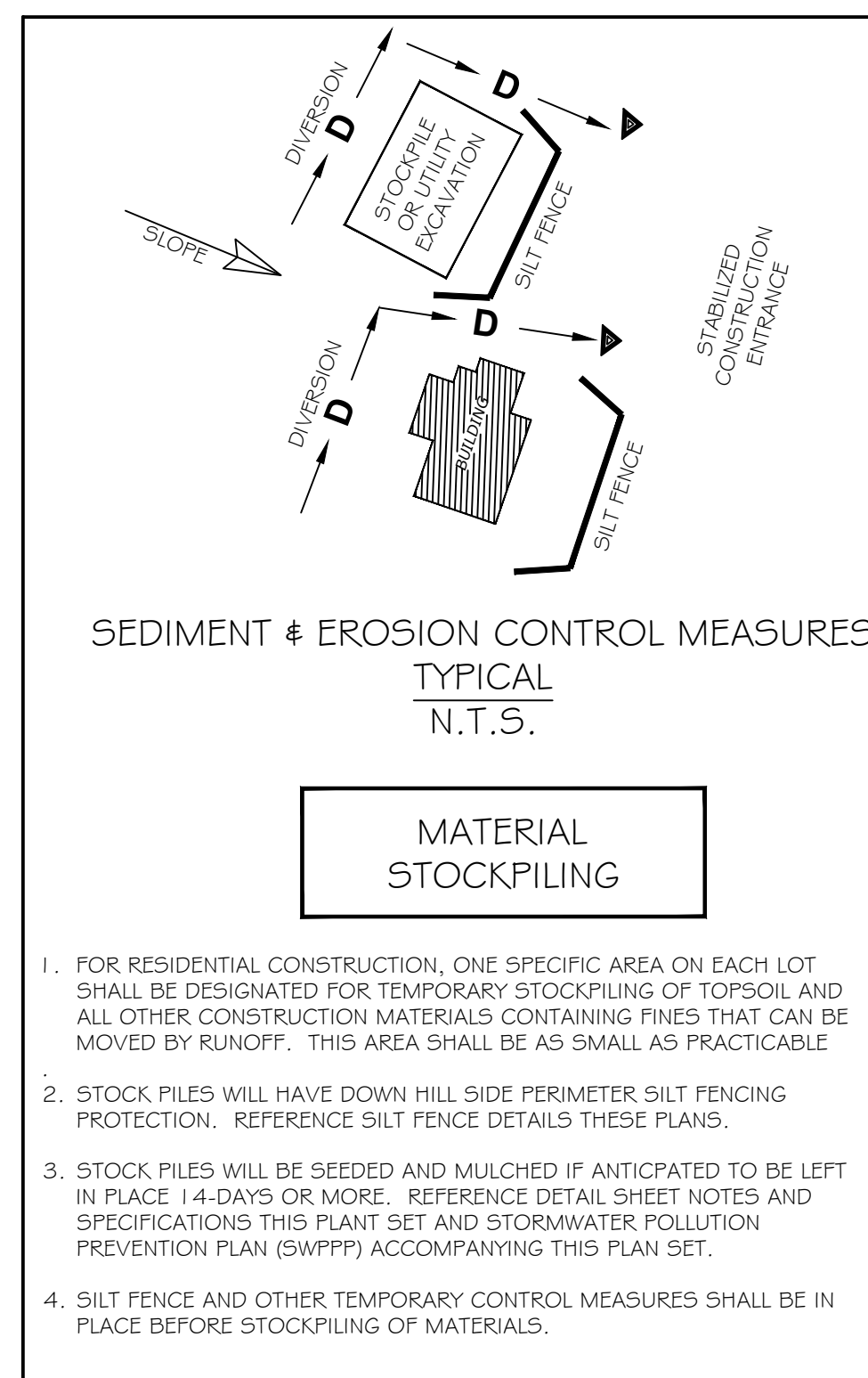

## SEDIMENT & EROSION CONTROL MEASURES TYPICAL N.T.S.

1. FOR RESIDENTIAL CONSTRUCTION, ONE SPECIFIC AREA ON EACH LOT SHALL BE DESIGNATED FOR TEMPORARY STOCKPILING OF TOPSOIL AND ALL OTHER CONSTRUCTION MATERIALS CONTAINING FINES THAT CAN BE MOVED BY RUNOFF. THIS AREA SHALL BE AS SMALL AS PRACTICABLE
2. STOCK PILES WILL HAVE DOWN HILL SIDE PERIMETER SILT FENCING PROTECTION. REFERENCE SILT FENCE DETAILS THESE PLANS.
3. STOCK PILES WILL BE SEEDED AND MULCHED IF ANTICIPATED TO BE LEFT IN PLACE 14-DAYS OR MORE. REFERENCE DETAIL SHEET NOTES AND SPECIFICATIONS THIS PLANT SET AND STORMWATER POLLUTION PREVENTION PLAN (SWPPP) ACCOMPANYING THIS PLAN SET.
4. SILT FENCE AND OTHER TEMPORARY CONTROL MEASURES SHALL BE IN PLACE BEFORE STOCKPILING OF MATERIALS.

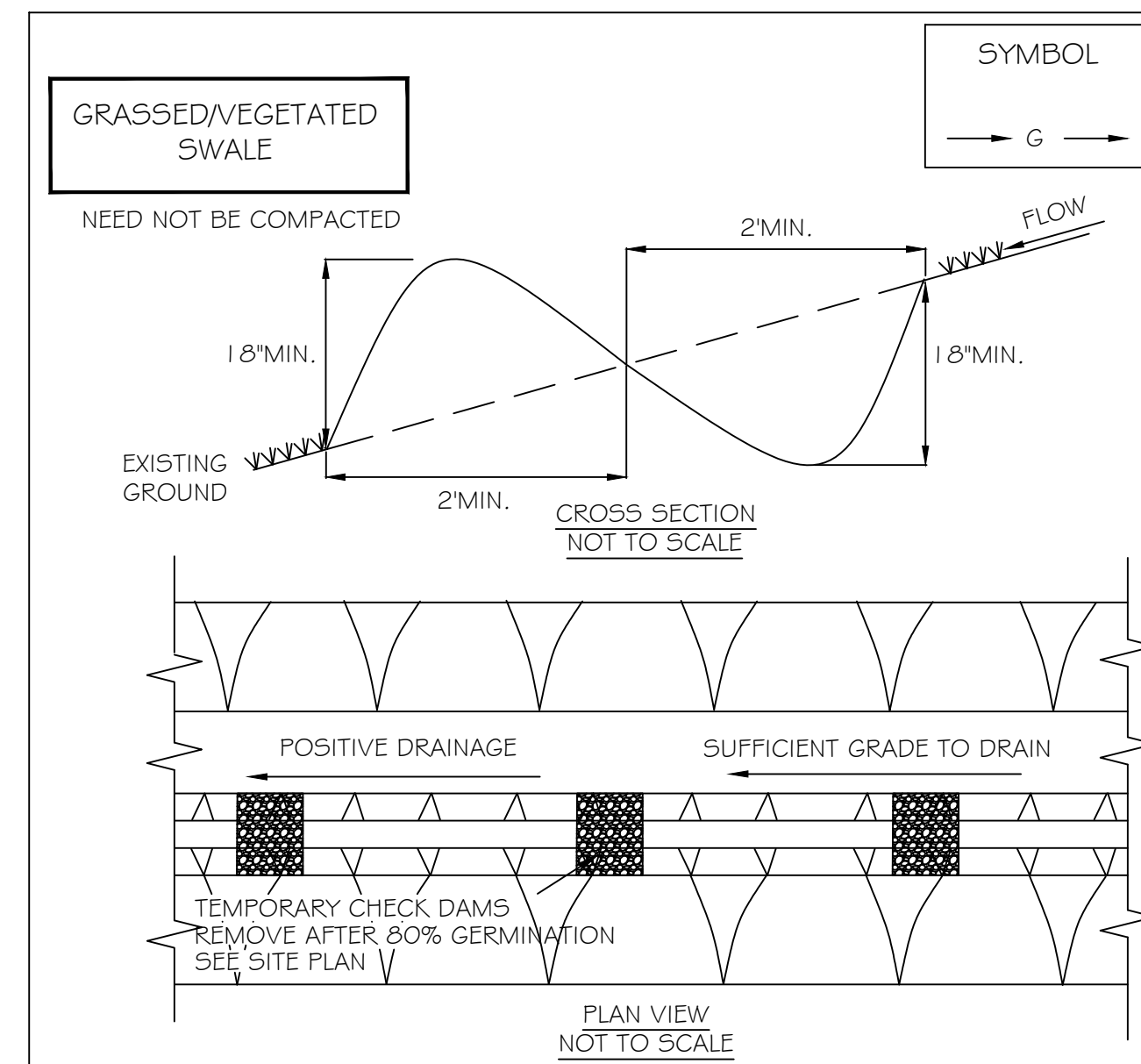

## CONSTRUCTION SPECIFICATIONS

### GRASSED/VEGETATED SWALE

1. DRAINAGE AREA SHALL BE LESS THAN 5 ACRES.
2. HEIGHT SHALL BE NO LESS THAN 18-INCHES FROM BOTTOM OF SWALE TO TOP OF DIKE EVENLY DIVIDED BETWEEN DIKE HEIGHT AND SWALE DEPTH.
3. BOTTOM WIDTH OF DIKE SHALL BE NO LESS THAN 2-FEET.
4. WIDTH OF SWALE SHALL BE NO LESS THAN 2-FEET.
5. SWALE SHALL HAVE POSITIVE DRAINAGE TO AN ADEQUATELY STABILIZED OUTLET TO AN UNDISTURBED AREA. MAXIMUM ALLOWABLE GRADE NOT TO EXCEED 8%.
6. THE DISTURBED AREA OF THE DIKE AND SWALE SHALL BE STABILIZED WITHIN 7 DAYS OF INSTALLATION, IN ACCORDANCE WITH THE STANDARD SPECIFICATIONS FOR TEMPORARY SWALES.
7. DIVERTED RUNOFF FROM A DISTURBED OR EXPOSED UPLAND AREA SHALL BE CONVEYED TO A SEDIMENT TRAPPING DEVICE SUCH AS A TRAP, BASIN, OR TO AN AREA PROTECTED BY ANY OF THESE PRACTICES
8. PERIODIC INSPECTION AND REQUIRED MAINTENANCE MUST BE PROVIDED AFTER EACH RAIN EVENT.

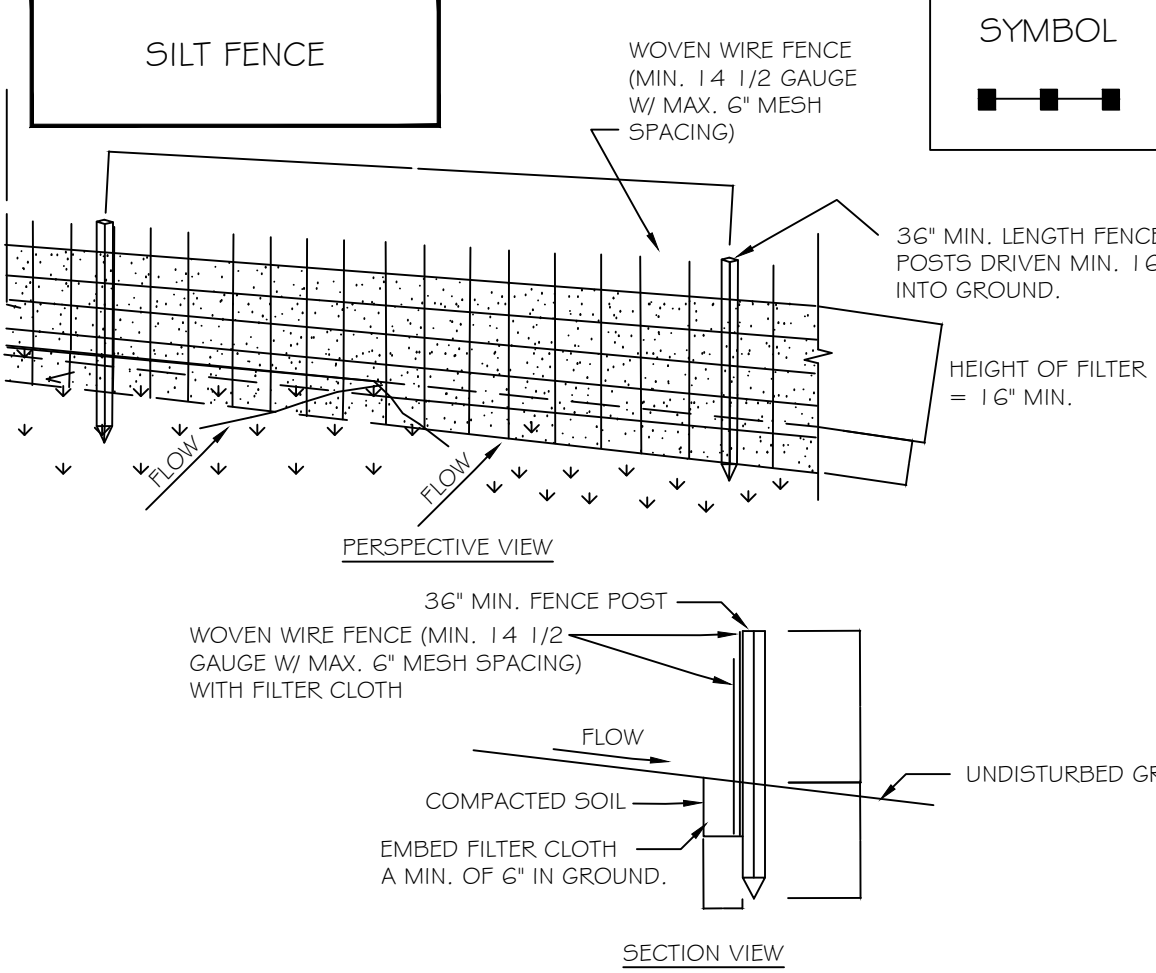

## CONSTRUCTION SPECIFICATIONS

1. WOVEN WIRE FENCE TO BE FASTENED SECURELY TO FENCE POSTS WITH WIRE TIES OR STAPLES. POSTS SHALL BE STEEL EITHER 1" OR 1 1/2" TYPE OR HARDWOOD.
2. FILTER CLOTH TO BE TO BE FASTENED SECURELY TO WOVEN WIRE FENCE WITH TIES SPACED EVERY 24" AT TOP AND MID SECTION. FENCE SHALL BE WOVEN WIRE, 1 1/2 GAUGE, 6" MAXIMUM MESH OPENING.
3. WHEN TWO SECTIONS OF FILTER CLOTH ADJOIN EACH OTHER THEY SHALL BE OVERLAPPED BY SIX INCHES AND FOLDED. FILTER CLOTH SHALL BE EITHER FILTER X, MIRAFL 100X, STABILINKA T140N, OR APPROVED EQUIVALENT.
4. PREFABRICATED UNITS SHALL BE GEOPAF, ENVIROFENCE, OR APPROVED EQUIVALENT.
5. MAINTENANCE SHALL BE PERFORMED AS NEEDED AND MATERIAL REMOVED WHEN "BULGES" DEVELOP IN THE SILT FENCE.

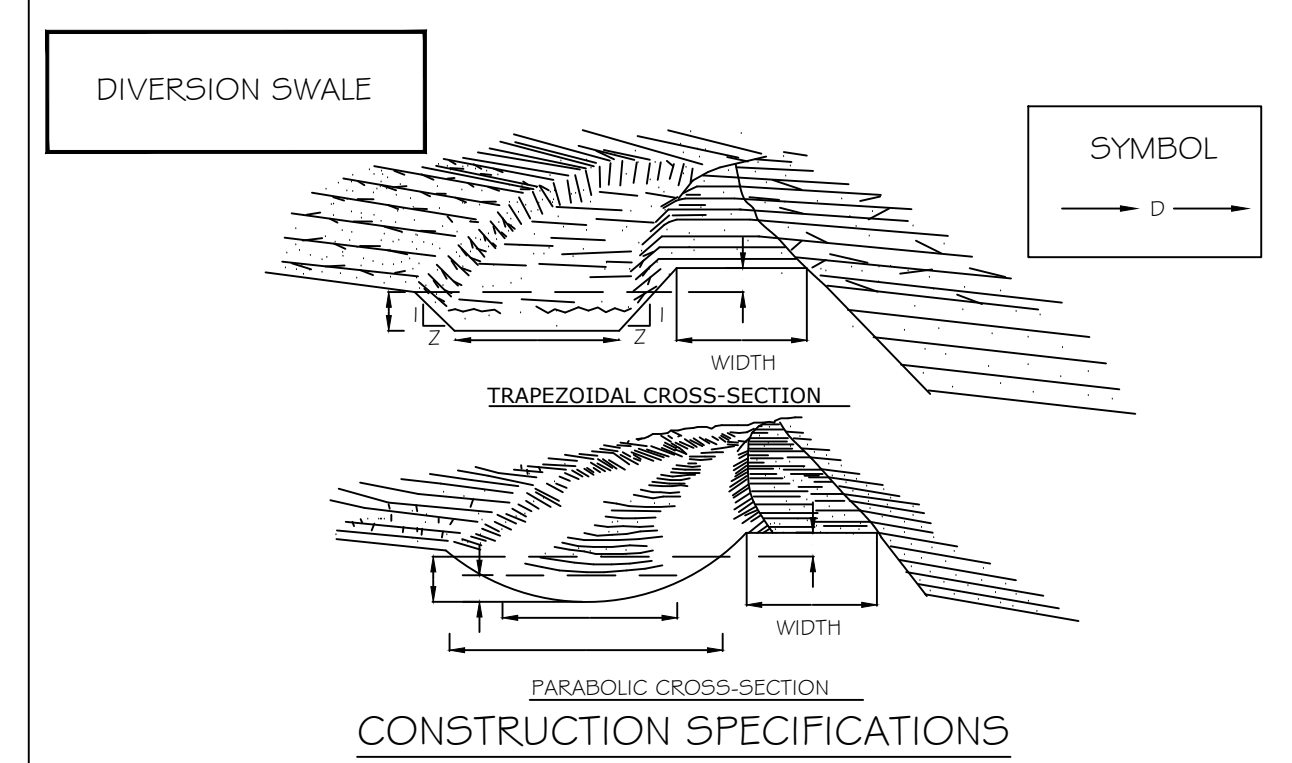

## CONSTRUCTION SPECIFICATIONS

1. ALL TREES, BRUSH, STUMPS, OBSTRUCTIONS, AND OTHER OBJECTIONABLE MATERIAL SHALL BE REMOVED AND DISPOSED OF SO AS NOT TO INTERFERE WITH THE PROPER FUNCTIONING OF THE DIVERSION.
2. THE DIVERSION SHALL BE EXCAVATED OR SHAPED TO LINE, GRADE, AND CROSS SECTION AS REQUIRED TO MEET THE CRITERIA SPECIFIED HEREIN, AND BE FREE OF BANK PROJECTIONS OR OTHER IRREGULARITIES WHICH WILL IMPEDE NORMAL FLOW.
3. FILLS SHALL BE COMPACTED AS NEEDED TO PREVENT UNEQUAL SETTLEMENT THAT WOULD CAUSE DAMAGE IN THE COMPLETE DIVERSION.
4. ALL EARTH REMOVED AND NOT NEEDED IN CONSTRUCTION SHALL BE SPREAD OR DISPOSED OF SO THAT IT WILL NOT INTERFERE WITH THE FUNCTIONING OF THE DIVERSION.
5. STABILIZATION SHALL BE DONE ACCORDING TO THE APPROPRIATE STANDARD AND SPECIFICATIONS FOR VEGETATIVE PRACTICES.
  - A. FOR DESIGN VELOCITIES OF LESS THAN 3.5 FT. PER. SEC., SEEDING AND MULCHING MAY BE USED FOR THE ESTABLISHMENT OF THE VEGETATION. IT IS RECOMMENDED THAT, WHEN CONDITIONS PERMIT, TEMPORARY DIVERSIONS OR OTHER MEANS SHOULD BE USED TO PREVENT WATER FROM ENTERING THE DIVERSION DURING THE ESTABLISHMENT OF THE VEGETATION.
  - B. FOR DESIGN VELOCITIES OF MORE THAN 3.5 FT. PER. SEC., THE DIVERSION SHALL BE STABILIZED WITH SOD, WITH SEEDING PROTECTED BY JUTE OR EXCELSIOR MATTING OR WITH SEEDING AND MULCHING INCLUDING TEMPORARY DIVERSION OF THE WATER UNTIL THE VEGETATION IS ESTABLISHED.

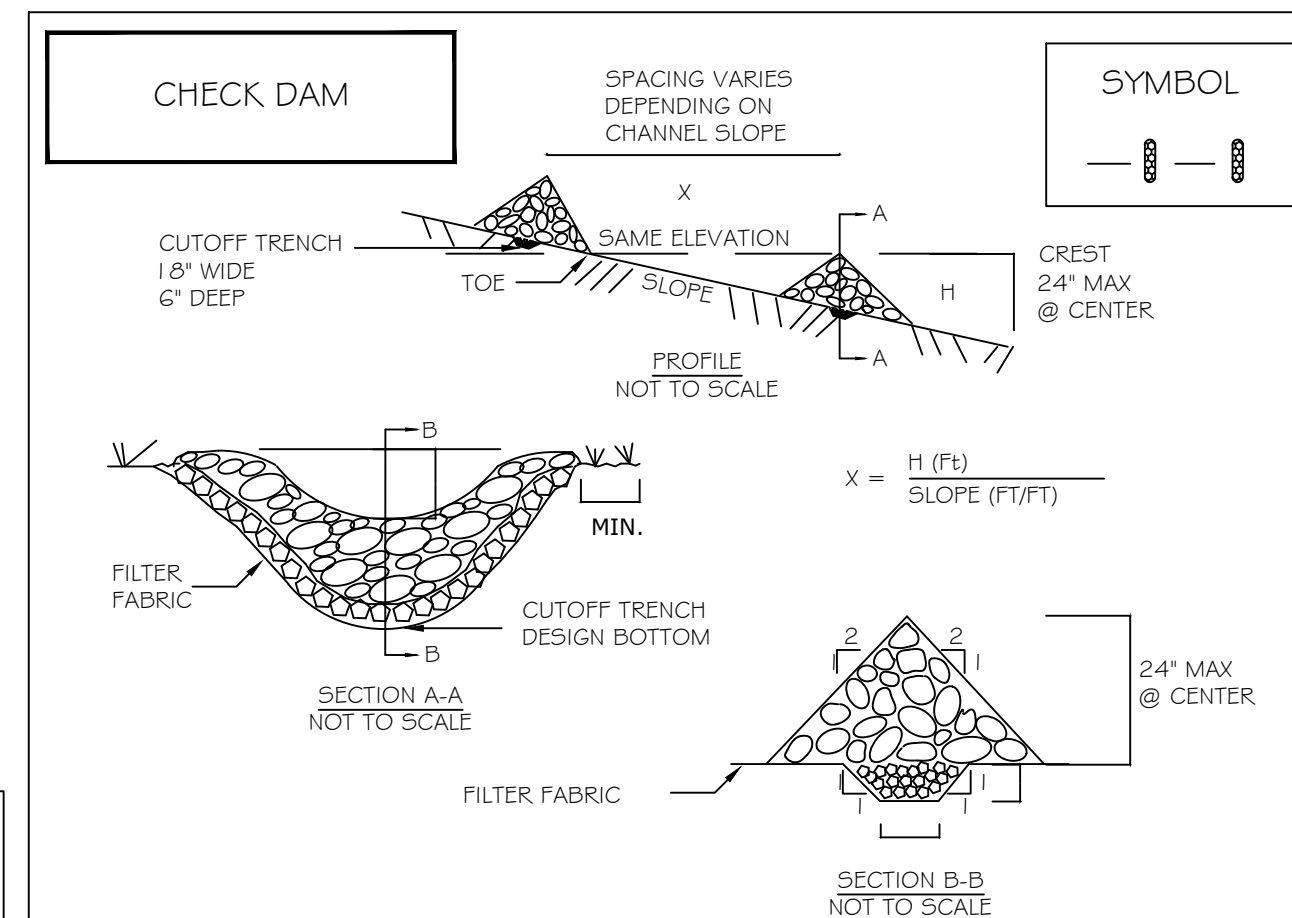

## CONSTRUCTION SPECIFICATIONS

1. STONE WILL BE PLACED ON A FILTER FABRIC FOUNDATION TO THE LINES, GRADES AND LOCATIONS SHOWN IN THE PLAN.
2. SET SPACING OF CHECK DAMS TO ASSUME THAT THE ELEVATIONS OF THE CREST OF THE DOWNSTREAM DAM IS AT THE SAME ELEVATION OF THE TOE OF THE UPSTREAM DAM.
3. EXTEND THE STONE A MINIMUM OF 1.5 FEET BEYOND THE DITCH BANKS TO PREVENT CUTTING AROUND THE DAM.
4. PROTECT THE CHANNEL DOWNSTREAM OF THE LOWEST CHECK DAM FROM SCOUR AND EROSION WITH STONE OR LINER AS APPROPRIATE.
5. ENSURE THAT CHANNEL APPURTENANCES SUCH AS CULVERT ENTRANCES BELOW CHECK DAMS ARE NOT SUBJECT TO DAMAGE OR BLOCKAGE FROM DISPLACED STONE. MAXIMUM DRAINAGE AREA 2 ACRES.



## CONSTRUCTION SPECIFICATIONS

### DESIGN CRITERIA

1. THE WASHOUT FACILITY SHOULD BE SIZED TO CONTAIN SOLIDS, WASHWATER AND RAINFALL AND SIZED TO ALLOW FOR THE EVAPORATION OF THE WASHWATER AND RAINFALL.
2. WASHWATER SHALL BE ESTIMATED AT 7 GALLONS PER CHUTE AND 50 GALLONS PER HOPPER OF CONCRETE PUMP TRUCK AND/OR DISCHARGING DRUM.
3. THE MINIMUM SIZE SHALL BE 8' X 8' AT THE BOTTOM AND 2' DEEP. IF EXCAVATED, THE SIDE SLOPES SHALL BE 2 HORIZONTAL : 1 VERTICAL.
4. LOCATE THE FACILITY A MINIMUM OF 100' FROM DRAINAGE SWALES, STORM DRAIN INLETS, WETLANDS, STREAMS AND OTHER SURFACE WATERS. PREVENT SURFACE WATER FROM ENTERING THE STRUCTURE EXCEPT FOR THE ACCESS ROAD.
5. PROVIDE APPROPRIATE ACCESS WITH A GRAVEL ACCESS ROAD SLOPED DOWN TO STRUCTURE.
6. SIGNS SHALL BE PLACED TO DIRECT DRIVERS TO THE FACILITY AFTER THEIR LOAD IS DISCHARGED.

THE LINER SHALL BE PLASTIC SHEETING WITH A MIN. THICKNESS OF 10 MILS WITH NO HOLES OR TEARS. ANCHOR THE LINER TO THE TOP OF THE PIT WITH AN EARTHEN BERM, SAND BAGS, STONE, ETC.

### MAINTENANCE

1. INSPECT ALL FACILITIES DAILY. REPAIR ALL DAMAGED OR LEAKING WASHOUT STATIONS IMMEDIATELY.
2. PUMP OUT ANY ACCUMULATED RAINWATER OVER HARDENED CONCRETE.
3. ACCUMULATED HARDENED MATERIAL SHALL BE REMOVED WHEN 75% OF THE STORAGE CAPACITY OF THE STRUCTURE IS FILLED.
4. DISPOSE OF HARDENED MATERIAL OFF-SITE IN A C&D LANDFILL. ON-SITE DISPOSAL IS ACCEPTABLE IF IT HAS BEEN APPROVED AND ACCEPTED AS PART OF THE SWPPP.
5. REPLACE THE PLASTIC LINER WITH EACH CLEANING OF WASHOUT FACILITY.
6. INSPECT THE PROJECT SITE FREQUENTLY TO ENSURE THAT NO CONCRETE DISCHARGES ARE TAKING PLACE IN NON-DESIGNATED AREAS.

## E&SC DETAILS

VILLAGE CIRCLE - PHASE 7  
LUCENTE HOMES/VILLAGE SOLARS  
LANSLING (T) TOMPKINS CO. N.Y.

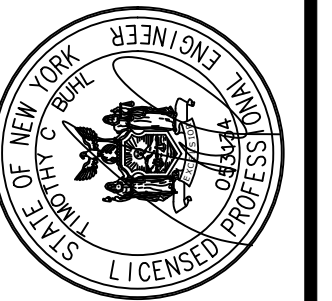

## TIMOTHY C. BUHL, P.E.

35 FIRE LANE 24, AUBURN, NY 13021

DATE: July 19, 2022

SCALE: N.T.S.

DRAWN: SDG

JOB:

SHEET:

ST-4



Bioretention Suggested Plantings -  
USDA Zone 5A

SHRUBS	HERBACEOUS PLANTS
Witch Hazel <i>Hamamelis virginiana</i>	Cinnamon Fern <i>Osmunda cinnamomea</i>
Winterberry <i>Ilex verticillata</i>	Cutleaf Coneflower <i>Rudbeckia laciniata</i>
Arrowwood <i>Viburnum dentatum</i>	Woolgrass <i>Scirpus cyperinus</i>
Brook-side Alder <i>Alnus serrulata</i>	New England Aster <i>Aster novae-angliae</i>
Red-Osier Dogwood <i>Cornus stolonifera</i>	Fox Sedge <i>Carex vulpinoidea</i>
Sweet Pepperbush <i>Clethra alrifolia</i>	Spotted Joe-Pye Weed <i>Eupatorium maculatum</i>
	Switch Grass <i>Panicum virgatum</i>
	Great Blue Lobelia <i>Lobelia siphatica</i>
	Wild Bergamot <i>Mondarda fistulosa</i>
	Red Milkweed <i>Asclepias incarnata</i>

NOTES:  
BASIN EMBANKMENT CONSTRUCTION:

1: EMBANKMENT MATERIAL SPECIFICATIONS: EMBANKMENT CORE AND CUT OFF TRENCH MATERIAL SHALL BE MATERIAL CONFORMING TO UNIFIED SOIL CLASSIFICATION GC, SC, CH, OR CL WITH AT LEAST 30% PASSING #200 SIEVE. CORE AND CUT OFF TRENCH MATERIAL SHALL BE STOCKPILED SEPARATELY FROM OUTER SHELL MATERIAL. MATERIAL SHALL BE FREE OF ROOTS, STUMPS, WOOD, RUBBISH, STONES GREATER THAN 6-INCHES, FROZEN OR OTHER OBJECTIONABLE MATERIALS. STOCKPILED MATERIAL SHALL BE COVERED AND PROTECTED FROM WATER, TRAFFIC AND OTHER DELETERIOUS SUBSTANCES OR PROCESSES.

2: EMBANKMENT COMPACTION: EMBANKMENT FILL SHALL BE PLACED IN 12-INCH LIFTS MAXIMUM AND COMPACTED. THE MINIMUM REQUIRED DENSITY SHALL NOT BE LESS THAN 95% OF MAXIMUM DRY DENSITY WITH A MOISTURE CONTENT WITHIN 2% OF OPTIMUM. ALL COMPACTION TO BE DETERMINED BY AASHTO METHOD 99 STANDARD PROCTOR.

3: EMBANKMENT CORE DIMENSIONS: THE CORE SHALL BE PARALLEL TO THE CENTERLINE OF THE EMBANKMENT AS SHOWN ON THE PLANS. THE TOP WIDTH OF THE CORE SHALL BE A MINIMUM OF FOUR FEET. THE HEIGHT SHALL EXTEND UP TO AT LEAST THE 10 YEAR WATER ELEVATION OR AS SHOWN ON THE PLANS. THE SIDE SLOPES SHALL BE 1 TO 1 OR FLATTER. THE CORE SHALL BE COMPACTED WITH CONSTRUCTION COMPACTION EQUIPMENT, ROLLERS, OR TAMPS TO ASSURE MAXIMUM DENSITY AND MINIMUM PERMEABILITY. THE CORE SHALL BE CONSTRUCTED/PLACED CONCURRENTLY WITH THE OUTER SHELL OF THE EMBANKMENT.

4: EMBANKMENT SURFACE: A 4-INCH LAYER OF TOPSOIL SHALL BE PLACED ON ENTIRE SURFACE AREA OF THE EMBANKMENT. GOOD GRASSSED COVER SHALL BE ESTABLISHED BY SEEDING, LIMING, FERTILIZING, MULCHING, ETC. IN ACCORDANCE WITH NEW YORK STATE STANDARDS AND SPECIFICATIONS FOR SOIL EROSION AND SEDIMENT CONTROL. EMBANKMENT SHALL BE KEPT FREE OF WOODY PLANT GROWTH AND TREES.

STONE LINING FOR STORMWATER CONVEYANCE SECTIONS						
MIN THICKNESS (THK)	STONE FILLING ITEM	V MAX*2 2' DEPTH	SEE NOTES	STONE SIZE <sup>1</sup>	PERCENT OF TOTAL BY WEIGHT	MANNING'S ROUGHNESS COEFF "N"
9"	FINE	11.0 FPS	2,3,4	SMALLER THAN 8" LARGER THAN 3" SMALLER THAN NO. 10 SIEVE	90-100 50-100 0-10	0.0314
15"	LIGHT	13.0 FPS	2,3,4	LIGHTER THAN 100 LBS LARGER THAN 6" SMALLER THAN 1/2"	90-100 50-100 0-10	0.0352
18"	MEDIUM	15.5 FPS	2,3,4	HEAVIER THAN 100 LBS SMALLER THAN 4"	50-100 0-10	0.0395
30"	HEAVY	17.0 FPS	2,3,4	HEAVIER THAN 100 LBS SMALLER THAN 6"	50-100 0-10	0.0423

\*1 SOURCE: HYDRAULIC ENGINEERING CIRCULAR NO. 15 DESIGN OF STABLE CHANNELS WITH FLEXIBLE LININGS  
\*2 SOURCE: SOILS DESIGN PROCEDURE SDP2, BANK AND CHANNEL PROTECTIVE LINING DESIGN PROCEDURES

NOTES:

- STONE SIZES, OTHER THAN WEIGHTS, REFER TO THE AVERAGE OF THE MAXIMUM AND MINIMUM DIMENSIONS OF A STONE PARTICLE AS ESTIMATED BY THE ENGINEER.
- MATERIALS SHALL CONTAIN LESS THAN 20 PERCENT OF STONES WITH A RATIO OF MAXIMUM TO MINIMUM DIMENSIONS GREATER THAN THREE.
- AIR-COOLED BLAST FURNACE SLAG, COBBLES OR GRAVEL HAVING AT LEAST ONE FRACTURED FACE PER ACCEPTABLE SUBSTITUTES FOR STONE UNDER THESE ITEMS, PROVIDED THAT SOUNDNESS AND GRADATION REQUIREMENTS ARE MET.
- MATERIALS SHALL CONTAIN A SUFFICIENT AMOUNT OF STONES SMALLER THAN THE AVERAGE STONE SIZE TO FILL THE SPACES BETWEEN THE STONES.

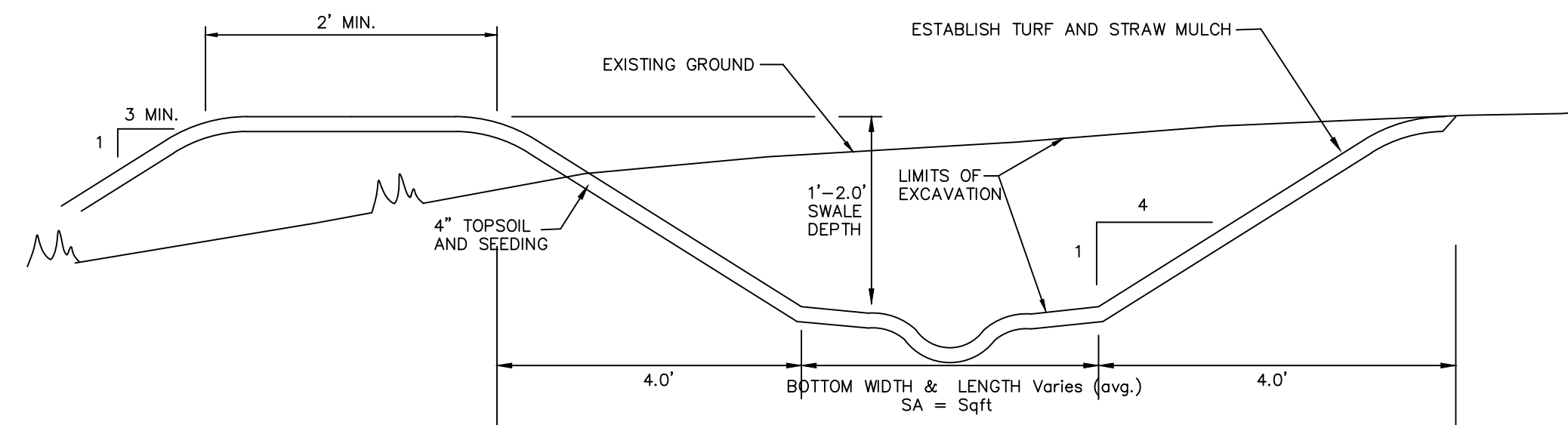

Bioretention Areas receiving flow from parking areas require a 2'W x 1' D pea stone lens at edge of practice

Cross-Section Bioretention Area

DIMENSIONS VARY AS PER PLAN

**SPECIFICATIONS FOR BIORETENTION SYSTEMS**

**Planting Soil**  
The soil shall be a uniform mix, free of stones, stumps, roots or other similar objects larger than two inches. No other materials or substances shall be mixed or dumped within the bioretention area that may be harmful to plant growth, or prove a hindrance to the planting or maintenance operations. The planting soil shall be free of noxious weeds.

Planting soil shall be of a sandy loam consistency containing approximately 75% concrete sand, 25% top soil and organics.

**Compaction**  
Minimize compaction of both the base of the bioretention area and the required backfill. Place soil in lifts 12" or great. Do not use heavy equipment within the bioretention area basin.

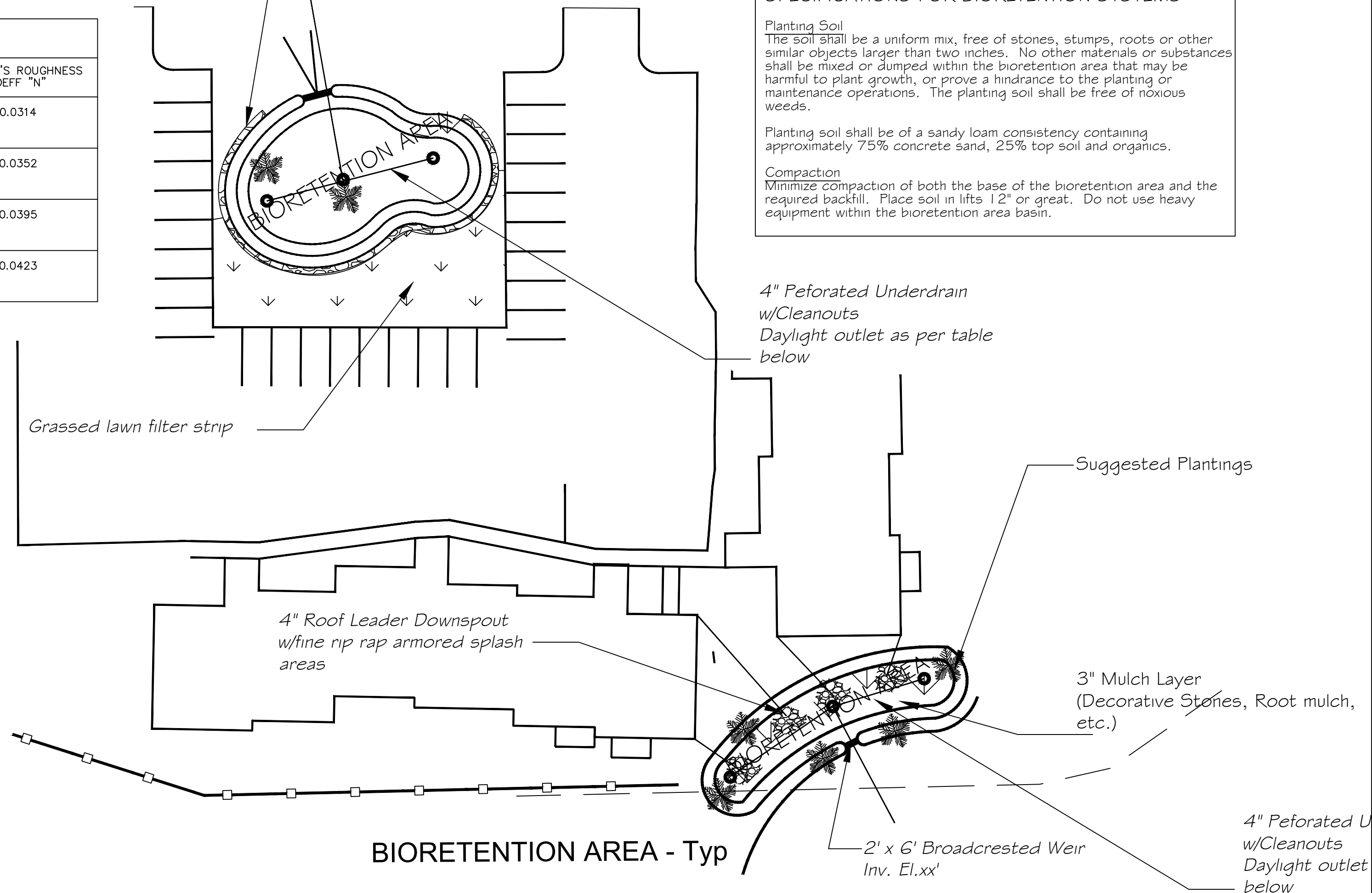

TYPICAL OUTLET, OVERFLOW, AND CHANNEL DETAILS  
REFERENCE THE BASIN PLAN & SECTION SHEETS FOR ELEVATIONS, DIMENSIONS, LINES & GRADES

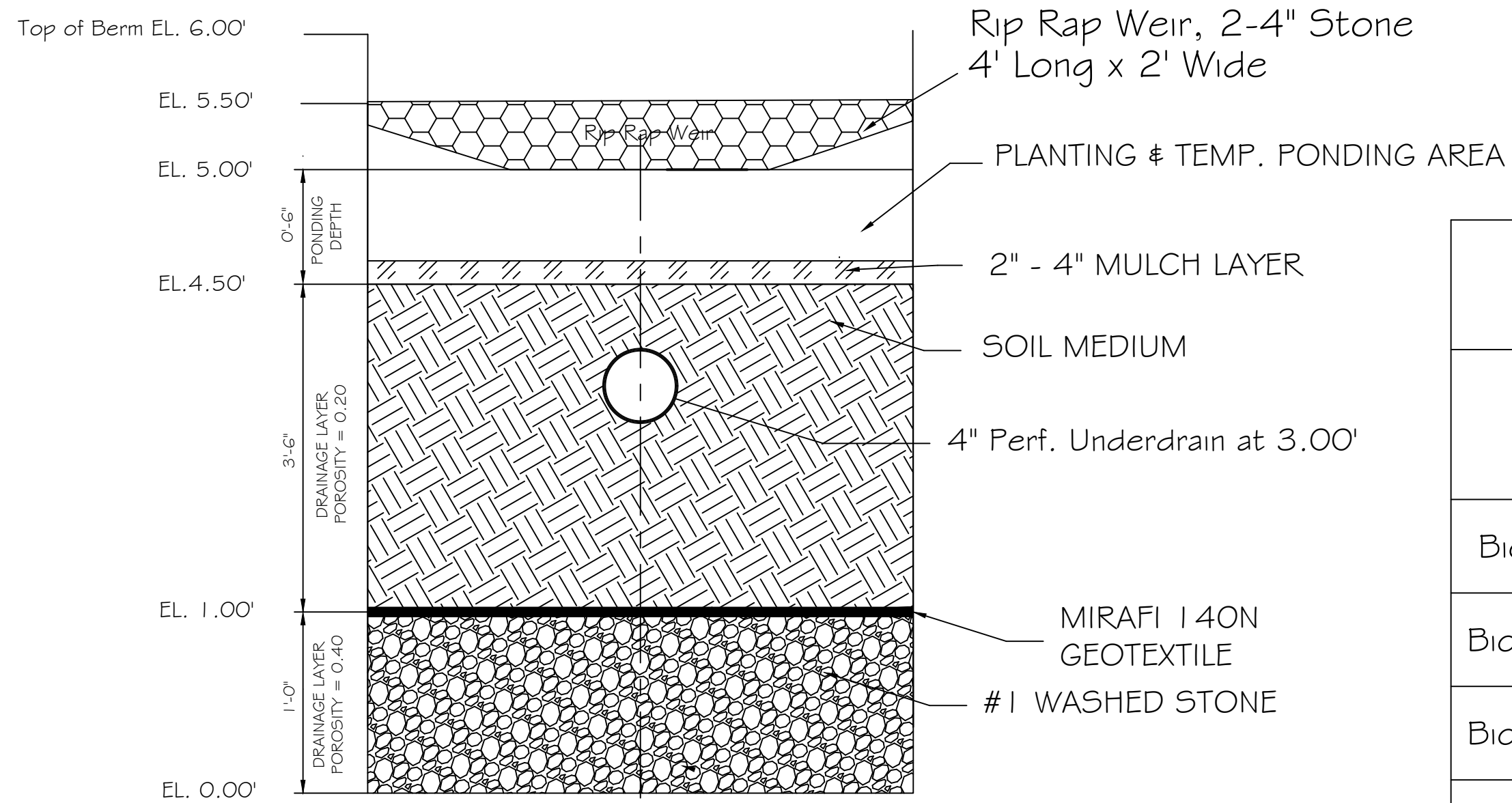

Bioretention Underdrain Layers, BR9, 12, 13, 14

Phase 7, Bioretention Area Details

Location	Bottom Length (ft)	Bottom Width (ft)	Bottom Surface Area (Sqft)	Floor of Practice El. (ft)	Bottom of Practice El. (ft)	Elevation of Underdrain El. (ft)	Underdrain Daylight El. (ft)	Berm El (ft)	Emergency Overflow Inv. El (ft)
Bioretention Area 9	48	12	600	1119.0	1115.5	1118.5	1118.0	1121.0	1119.5
Bioretention Area 12	70	17	1200	1119.0	1115.5	1118.5	1113.0	1121.0	1119.5
Bioretention Area 13	80	19	1500	1119.0	1115.5	1118.5	1118.0	1121.0	1119.5
Bioretention Area 14	65	34	2200	1364.0	1115.5	1118.5	1118.0	1121.0	1119.5

REVISIONS	
No.	Date (YY)

**BIORETENTION AREA DETAILS**

VILLAGE CIRCLE - PHASE 7  
LUCENTE HOMES/VILLAGE SOLARS  
LANSLING (T) TOMPKINS CO. N.Y.

LUCENTE HOLDINGS, INC  
381 HAGADORN HILL RD.  
SPICEY, NY 14883



**TIMOTHY C. BUHL, P.E.**  
35 FIRE LANE 24, AUBURN, NY 13021

DATE: Sept 6, 2022  
SCALE: 1"=50'  
DRAWN: SDG  
JOB:  
SHEET: ST-5



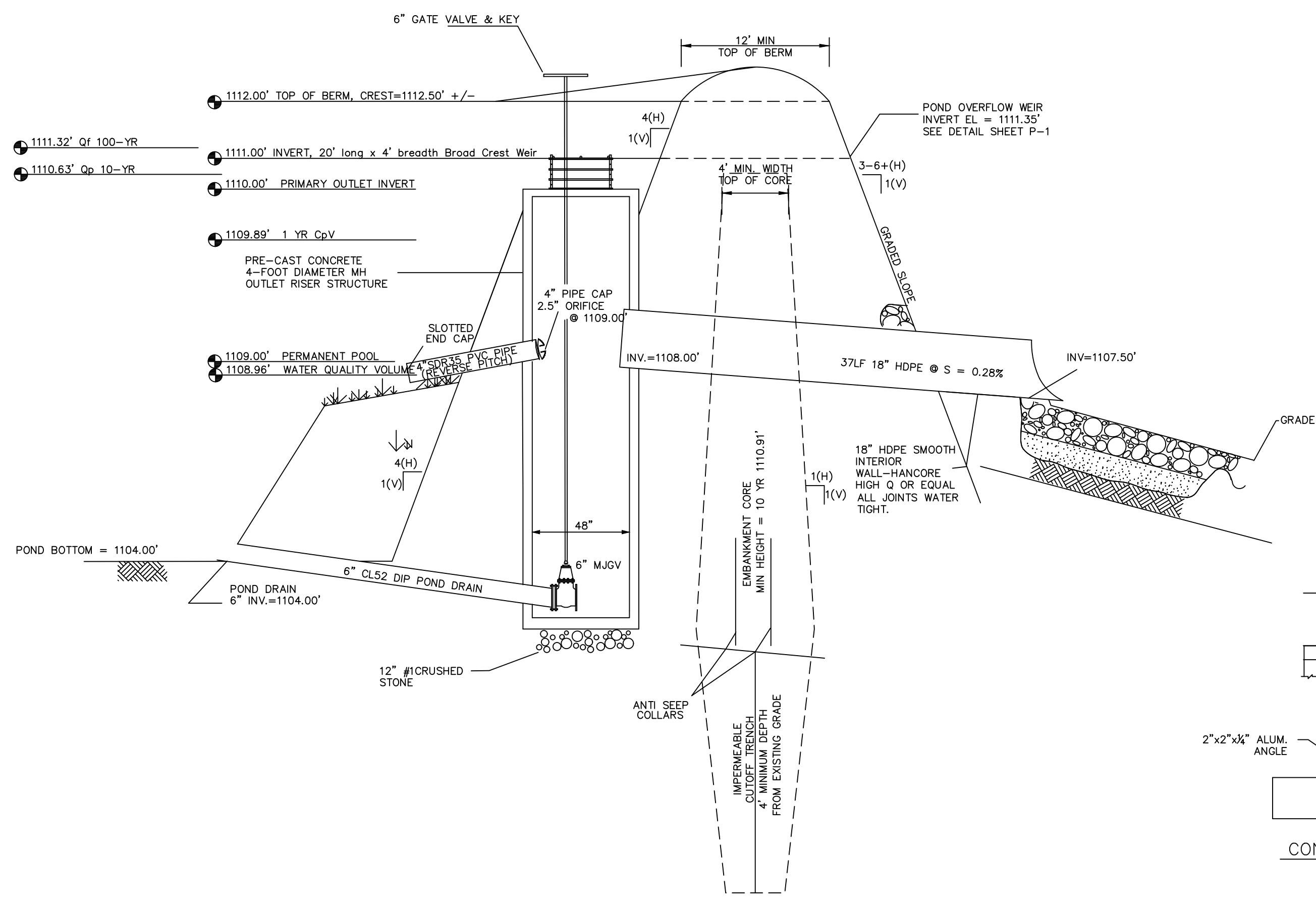

POND 1 OUTLET STRUCTURE

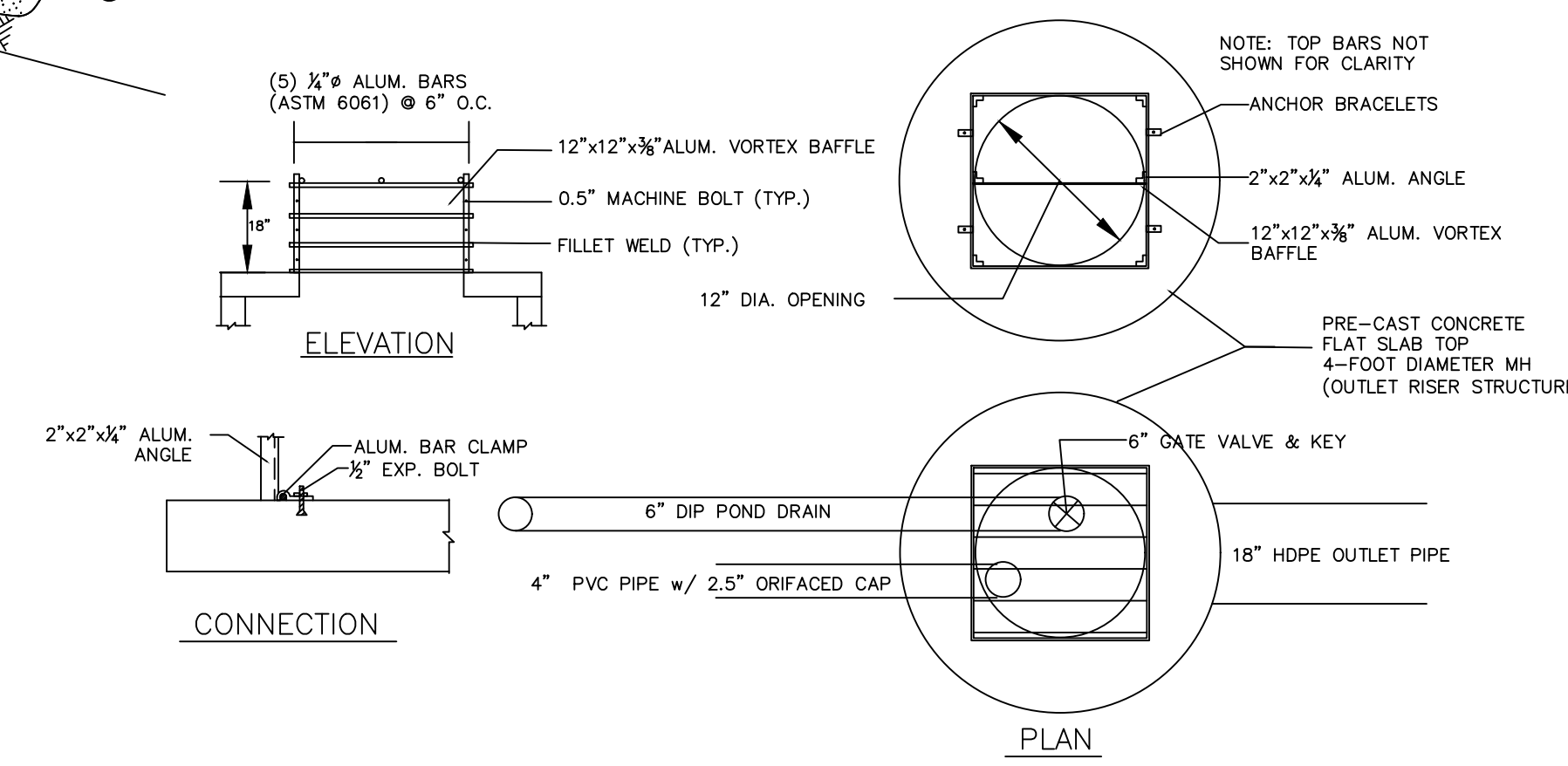

POND 1 OUTLET STRUCTURE & SECTION DETAILS

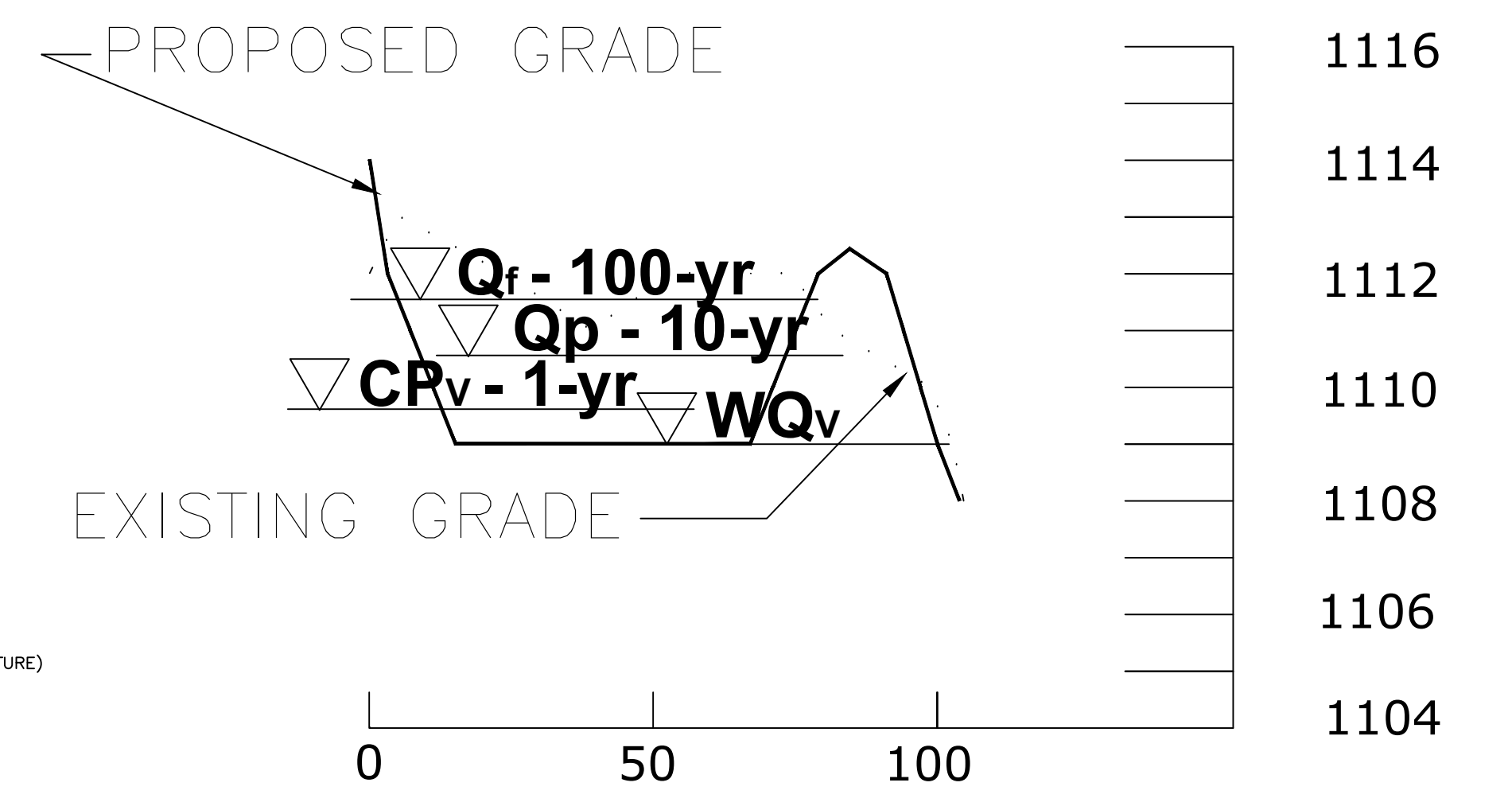

SECTION B - B  
Vertical Scale = 10X Horizontal

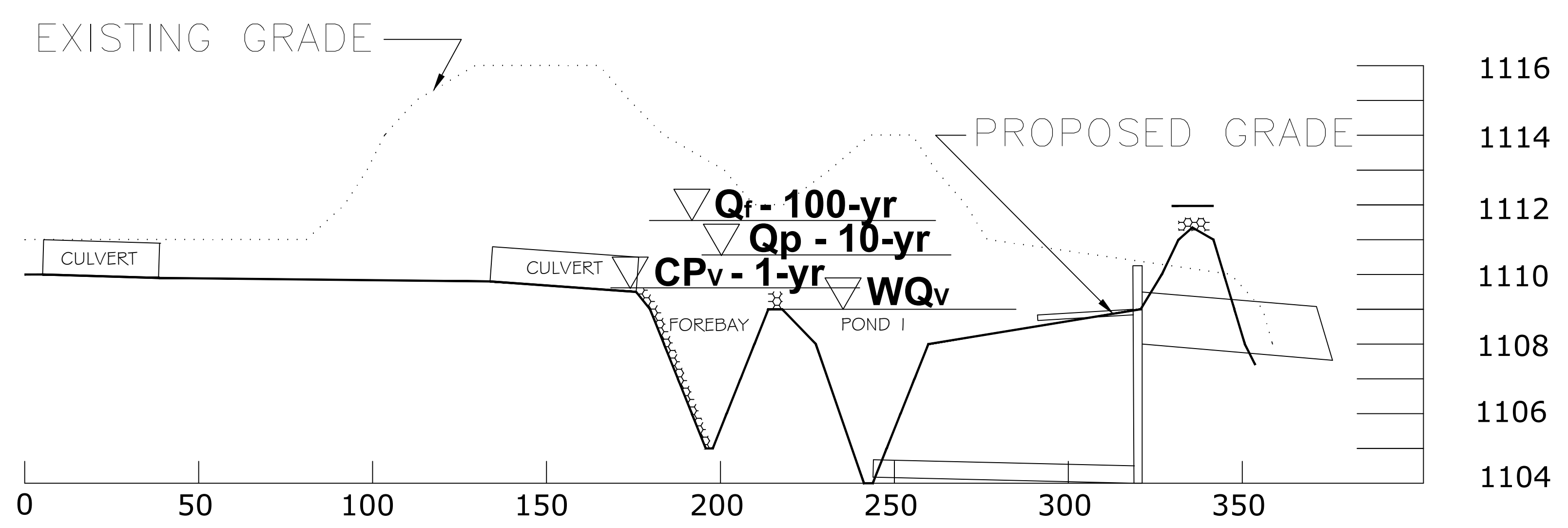
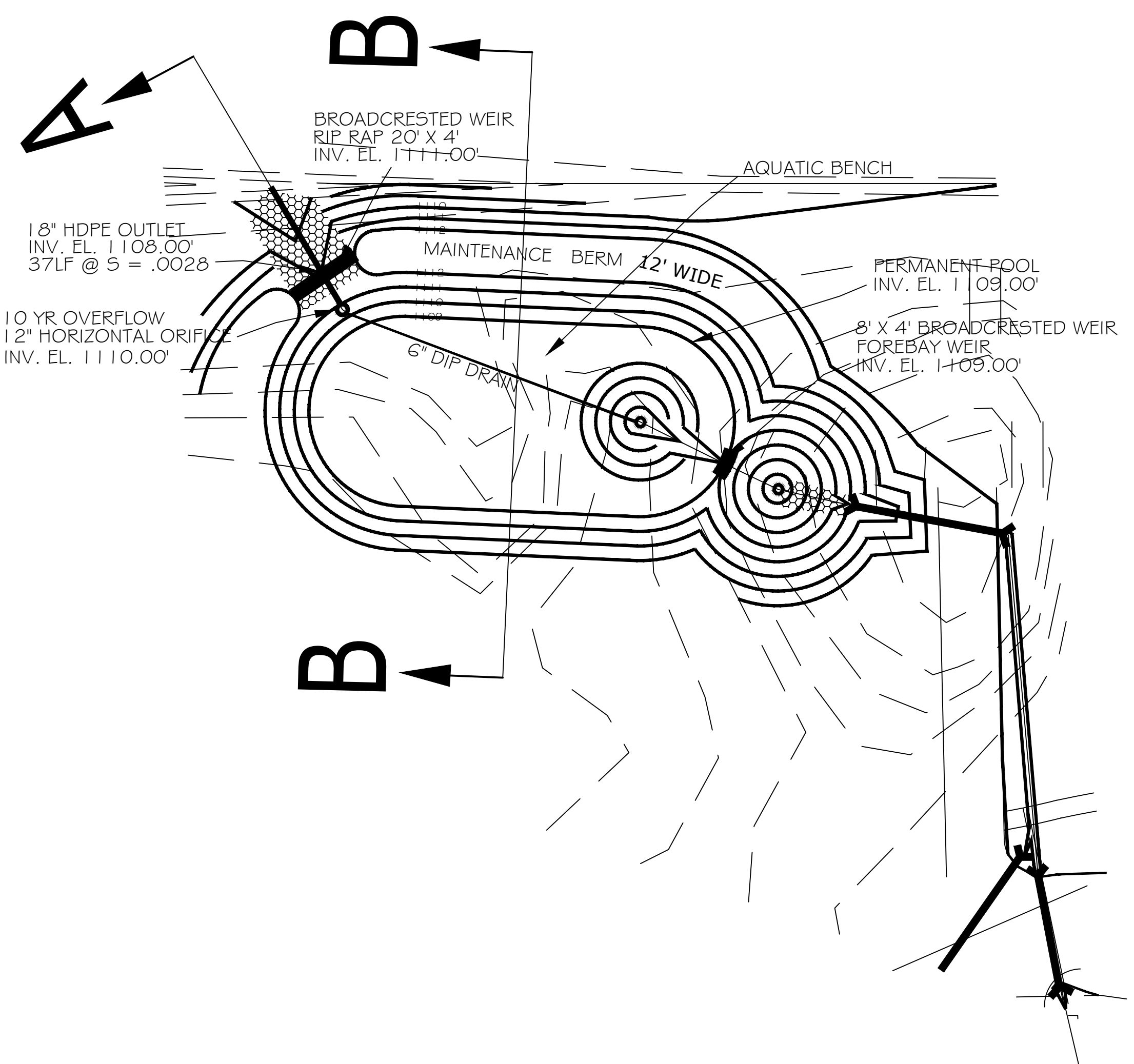

SECTION A - A  
Vertical Scale = 10X Horizontal

No.	Date	SYN.	Description

**POND 1 DETAILS**  
 LUCENTE HOLDINGS, INC  
 381 HAGADORN HILL RD.  
 SPENCER, NY 14883  
 VILLAGE CIRCLE - PHASE 7  
 LUCENTE HOMES/VILLAGE SOLARS  
 LANSLING (T) TOMPKINS CO. N.Y.

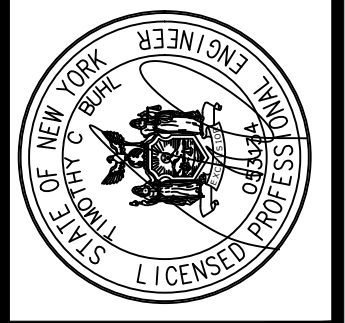

**TIMOTHY C. BUHL, P.E.**  
 35 FIRE LANE 24, AUBURN, NY 13021

DATE: Sept 6, 2022  
 SCALE: N.T.S.  
 DRAWN: SDG  
 JOB:  
 SHEET:  
**ST-6a**







**EXISTING FLOW CONDITIONS**  
AT DESIGN POINT - 1 (REACH DP-1 IN MODEL)

STORM EVENT	PEAK FLOW (CFS)	TOTAL VOLUME (CF)
1 YR, (2.3")	4.80	30,187
10 YR, (3.9")	20.87	103,368
100 YR, (5.5")	41.39	196,673

**PROPOSED FLOW CONDITIONS**  
AT DESIGN POINT - 1 (REACH DP-1 IN MODEL)

STORM EVENT	PEAK FLOW (CFS)	TOTAL VOLUME (CF)
1 YR, (2.3")	3.02	18,121
10 YR, (3.9")	12.93	83,156
100 YR, (5.5")	36.20	176,940

**EXISTING FLOW CONDITIONS**  
AT DESIGN POINT - 2 (REACH DP-2 IN MODEL)

STORM EVENT	PEAK FLOW (CFS)	TOTAL VOLUME (CF)
1 YR, (2.3")	3.49	17,380
10 YR, (3.9")	18.69	67,431
100 YR, (5.5")	39.35	134,470

**PROPOSED FLOW CONDITIONS**  
AT DESIGN POINT - 2 (REACH DP-2 IN MODEL)

STORM EVENT	PEAK FLOW (CFS)	TOTAL VOLUME (CF)
1 YR, (2.3")	4.76	20,604
10 YR, (3.9")	18.09	73,573
100 YR, (5.5")	38.69	158,428

Design Point  
1

Design Point  
2

Design Point  
3

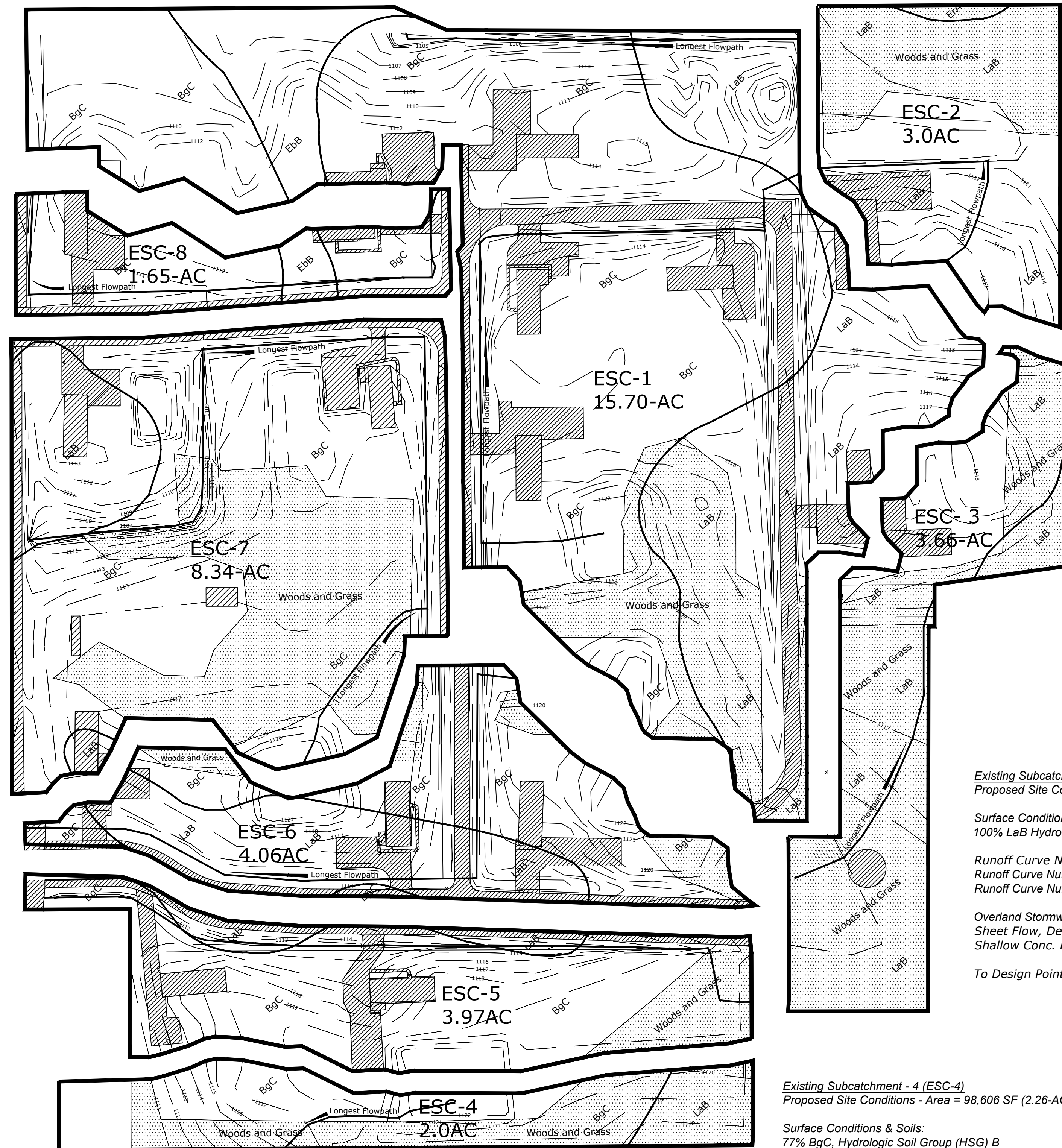

Existing Subcatchments

**Existing Subcatchment - 1 (ESC-1)**  
Proposed Site Conditions - Area = 683,765 SF (15.70-AC)

Surface Conditions & Soils:  
54% BgC Hydrologic Soil Group (HSG) B  
46% LaB, Ebb Hydrologic Soil Group (HSG) C

Runoff Curve Number = 98, Roofs, Parking, Sidewalks, etc., Good HSG B&C Soils  
Runoff Curve Number = 58, Woods and Grass Combination, Good HSG B Soils  
Runoff Curve Number = 72, Woods and Grass Combination, Good HSG C Soils  
Runoff Curve Number = 61, >75% Grass Cover, Good HSG B Soils  
Runoff Curve Number = 74, >75% Grass Cover, Good HSG C Soils

Overland Stormwater Runoff - Longest Flowpath = 1,893 lf +/-  
Sheet Flow, Dense Grass - 100 lf @ S = 3.5% avg.  
Sheet Flow, Dense Grass - 70 lf @ S = 7.8% avg.  
Trap/Vee Channel Flow - 488 lf @ S = 0.5% avg.  
Circular 8" Pipe - 31 lf @ S = 0.25% avg.  
Trap/Vee Channel Flow - 355 lf @ S = 0.80% avg.  
Circular 8" Pipe - 31 lf @ S = 0.25% avg.  
Sheet Flow, Grassed Channel - 818 lf @ S = 0.9% avg.

To Design Point 1 - (DP 1)

**Existing Subcatchment - 2 (ESC-2)**  
Proposed Site Conditions - Area = 130,953 SF (3.0-AC)

Surface Conditions & Soils:  
100% LaB, ErA, Hydrologic Soil Group (HSG) C

Runoff Curve Number = 98, Roofs, Parking, Sidewalks, etc., Good HSG C Soils  
Runoff Curve Number = 72, Woods and Grass Combination, Good HSG C Soils  
Runoff Curve Number = 74, >75% Grass Cover, Good HSG C Soils

Overland Stormwater Runoff - Longest Flowpath = 404 lf +/-  
Sheet Flow, Dense Grass - 100 lf @ S = 5.0% avg.  
Shallow Conc. Flow - Grass - 62 lf @ S = 4.1% avg.  
Trap Vee Channel Flow - 242 lf @ S = 0.5% avg.

To Design Point 1 - (DP 1)

**Existing Subcatchment - 3 (ESC-3)**  
Proposed Site Conditions - Area = 159,455 SF (3.66-AC)

Surface Conditions & Soils:  
100% LaB Hydrologic Soil Group (HSG) C

Runoff Curve Number = 98, Roofs, Parking, Sidewalks, etc., Good HSG C Soils  
Runoff Curve Number = 72, Woods and Grass Combination, Good HSG C Soils  
Runoff Curve Number = 74, >75% Grass Cover, Good HSG C Soils

Overland Stormwater Runoff - Longest Flowpath = 482 lf +/-  
Sheet Flow, Dense Grass - 100 lf @ S = 1.0% avg.  
Shallow Conc. Flow - Woodland - 382 lf @ S = 1.0% avg.

To Design Point 3 - (DP 3)

**Existing Subcatchment - 5 (ESC-5)**  
Proposed Site Conditions - Area = 173,660 SF (3.99-AC)

Surface Conditions & Soils:  
92.1% BgC, Hydrologic Soil Group (HSG) B  
7.9% LaB, Hydrologic Soil Group (HSG) C

Runoff Curve Number = 98, Roofs, Parking, Sidewalks, etc., Good HSG B&C Soils  
Runoff Curve Number = 58, Woods and Grass Combination, Good HSG B Soils  
Runoff Curve Number = 61, >75% Grass Cover, Good HSG B Soils  
Runoff Curve Number = 74, >75% Grass Cover, Good HSG C Soils

Overland Stormwater Runoff - Longest Flowpath = 1,089 lf +/-  
Sheet Flow, Dense Grass - 100 lf @ S = 1.4% avg.  
Shallow Conc. Flow - Woodland - 22 lf @ S = 0.5% avg.  
Trap/Vee Channel Flow - 464 lf @ S = 1.25% avg.  
Circular 8" Pipe - 30 lf @ S = 0.35% avg.  
Trap/Vee Channel Flow - 473 lf @ S = 1.05% avg.

To Design Point 3 - (DP 3)

**Existing Subcatchment - 4 (ESC-4)**  
Proposed Site Conditions - Area = 98,606 SF (2.26-AC)

Surface Conditions & Soils:  
77% BgC, Hydrologic Soil Group (HSG) B  
23% LaB, Hydrologic Soil Group (HSG) C

Runoff Curve Number = 58, Woods and Grass Combination, Good HSG B Soils  
Runoff Curve Number = 72, Woods and Grass Combination, Good HSG C Soils  
Runoff Curve Number = 61, >75% Grass Cover, Good HSG B Soils

Overland Stormwater Runoff - Longest Flowpath = 265 lf +/-  
Sheet Flow, Dense Grass - 100 lf @ S = 3.5% avg.  
Shallow Conc. Flow - Grassed Waterway - 100 lf @ S = 2.0% avg.  
Shallow Conc. Flow - Woodland - 62 lf @ S = 4.0% avg.

To Design Point 3 - (DP 3)

**Existing Subcatchment - 7 (ESC-7)**  
Proposed Site Conditions - Area = 363,256 SF (8.34-AC)

Surface Conditions & Soils:  
86.2% BgC Hydrologic Soil Group (HSG) B  
13.8% LaB Hydrologic Soil Group (HSG) C

Runoff Curve Number = 98, Roofs, Parking, Sidewalks, etc., Good HSG B&C Soils  
Runoff Curve Number = 58, Woods and Grass Combination, Good HSG B Soils  
Runoff Curve Number = 61, >75% Grass Cover, Good HSG B Soils  
Runoff Curve Number = 74, >75% Grass Cover, Good HSG C Soils

Overland Stormwater Runoff - Longest Flowpath = 1,494 lf +/-  
Sheet Flow, Dense Grass - 88 lf @ S = 6.0% avg.  
Sheet Flow, Woods - 12 lf @ S = 5.5% avg.  
Shallow Conc. Flow - Woodland - 195 lf @ S = 3.5% avg.  
Trap/Vee Channel Flow - 445 lf @ S = 1.0% avg.  
Circular 8" Pipe - 30 lf @ S = 0.50% avg.  
Trap/Vee Channel Flow - 724 lf @ S = 1.50% avg.

To Design Point 2 - (DP 2)

**Existing Subcatchment - 6 (ESC-6)**  
Proposed Site Conditions - Area = 176,894 SF (4.06-AC)

Surface Conditions & Soils:  
42% BgC Hydrologic Soil Group (HSG) B  
58% LaB Hydrologic Soil Group (HSG) C

Runoff Curve Number = 98, Roofs, Parking, Sidewalks, etc., Good HSG B&C Soils  
Runoff Curve Number = 58, Woods and Grass Combination, Good HSG B Soils  
Runoff Curve Number = 61, >75% Grass Cover, Good HSG B Soils  
Runoff Curve Number = 74, >75% Grass Cover, Good HSG C Soils

Overland Stormwater Runoff - Longest Flowpath = 1010 lf +/-  
Sheet Flow, Dense Grass - 56 lf @ S = 3.0% avg.  
Trap/Vee Channel Flow - 292 lf @ S = 0.5% avg.  
Circular 8" Pipe - 31 lf @ S = 0.25% avg.  
Trap/Vee Channel Flow - 631 lf @ S = 0.5% avg.

To Design Point 2 - (DP 2)

REFERENCE HYDROCAD (HYDRAULIC & HYDROLOGIC) MODELING RESULTS PRESENTED WITH THESE PLANS

REVISIONS

No. Date SYM. Description

HYDROLOGIC AND HYDRAULIC  
RUNOFF WORKSHEET EXISTING

LUCENTE HOLDINGS, INC  
381 HAGADORN HILL RD.  
SPENCER, NY 14883

VILLAGE CIRCLE - PHASE 7  
LUCENTE HOMES/VILLAGE SOLARS  
LANSLING (T) TOMPKINS CO. N.Y.

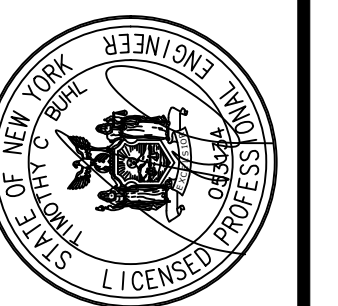

TIMOTHY C. BUHL, P.E.

35 FIRE LANE 24, AUBURN, NY 13021

DATE: Sept 6, 2022

SCALE: N.T.S.

DRAWN: SDG

JOB:

SHEET:

ST-7











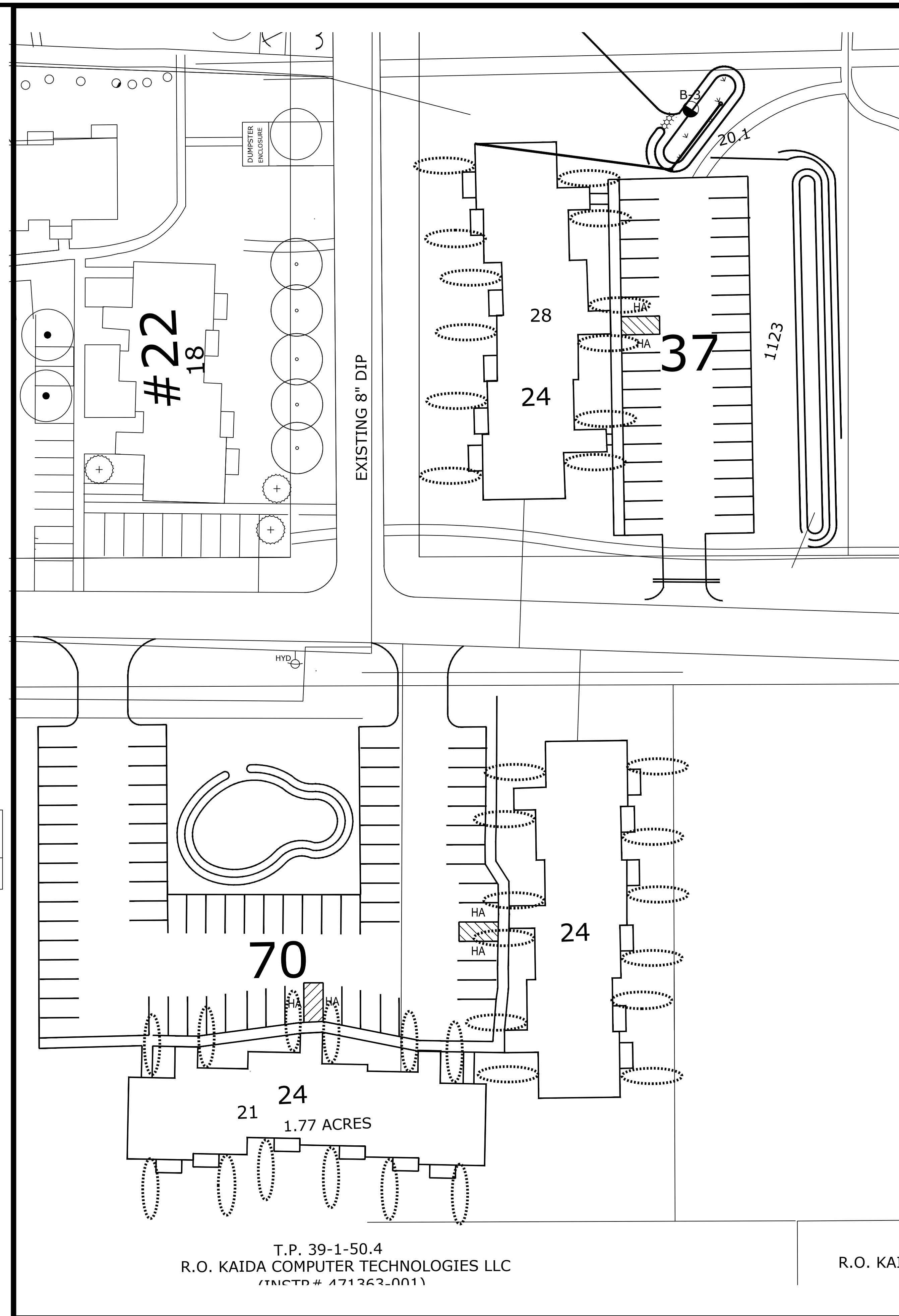
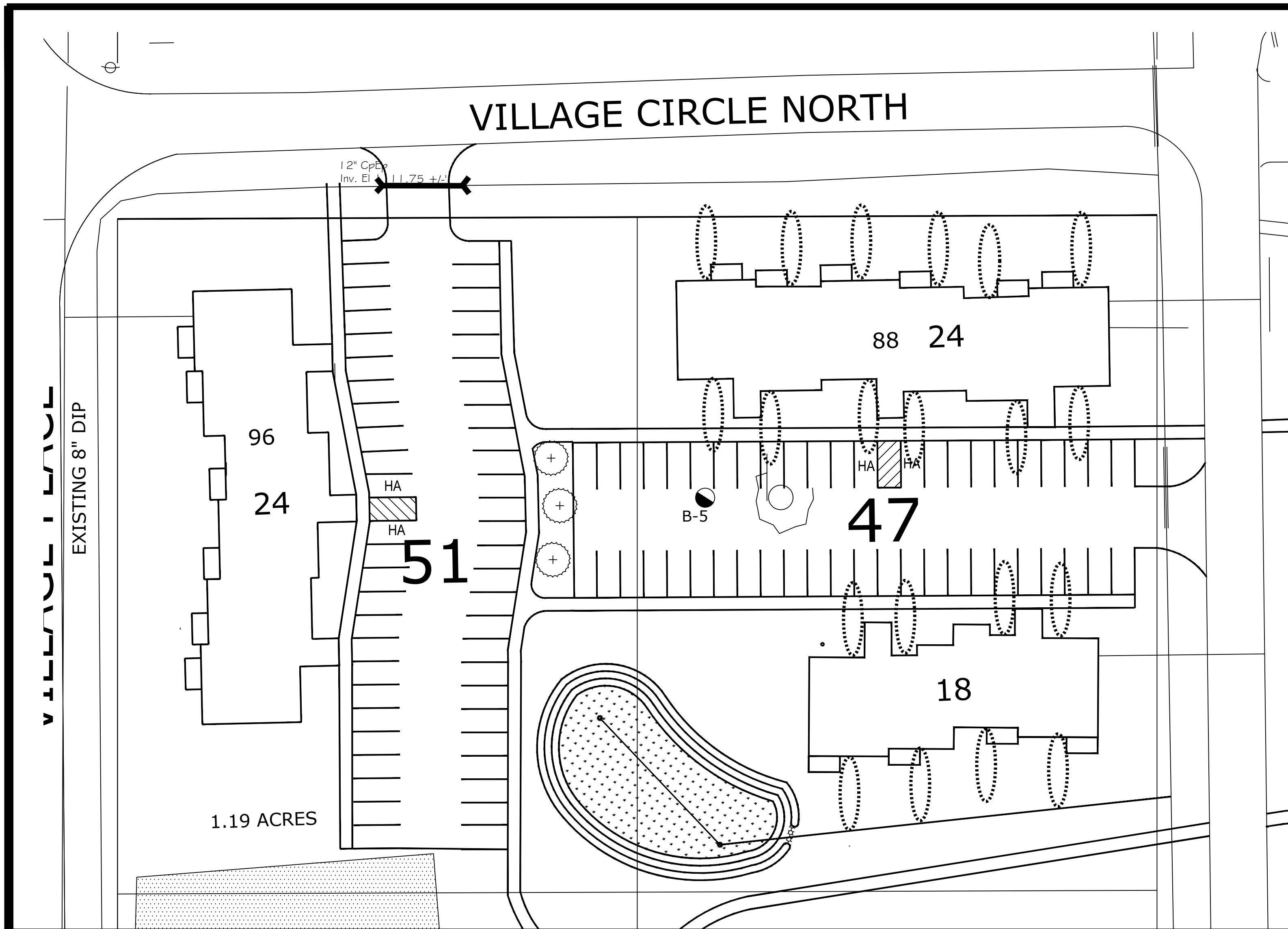

LIGHTING SCHEDULE

WATTS (W)	DESCRIPTION	COLOR TEMP (K)	LUMENS (lm)	EQUIV WATTAGE (W)	SIZE	BEAM ANGLE	COLOR	VOLTAGE	WET	ES
25	LED-FXSDWS25/33S/930/BK	3000K	1,750	250	5" x 7.5"	33°	BLACK	120-227V	*	*

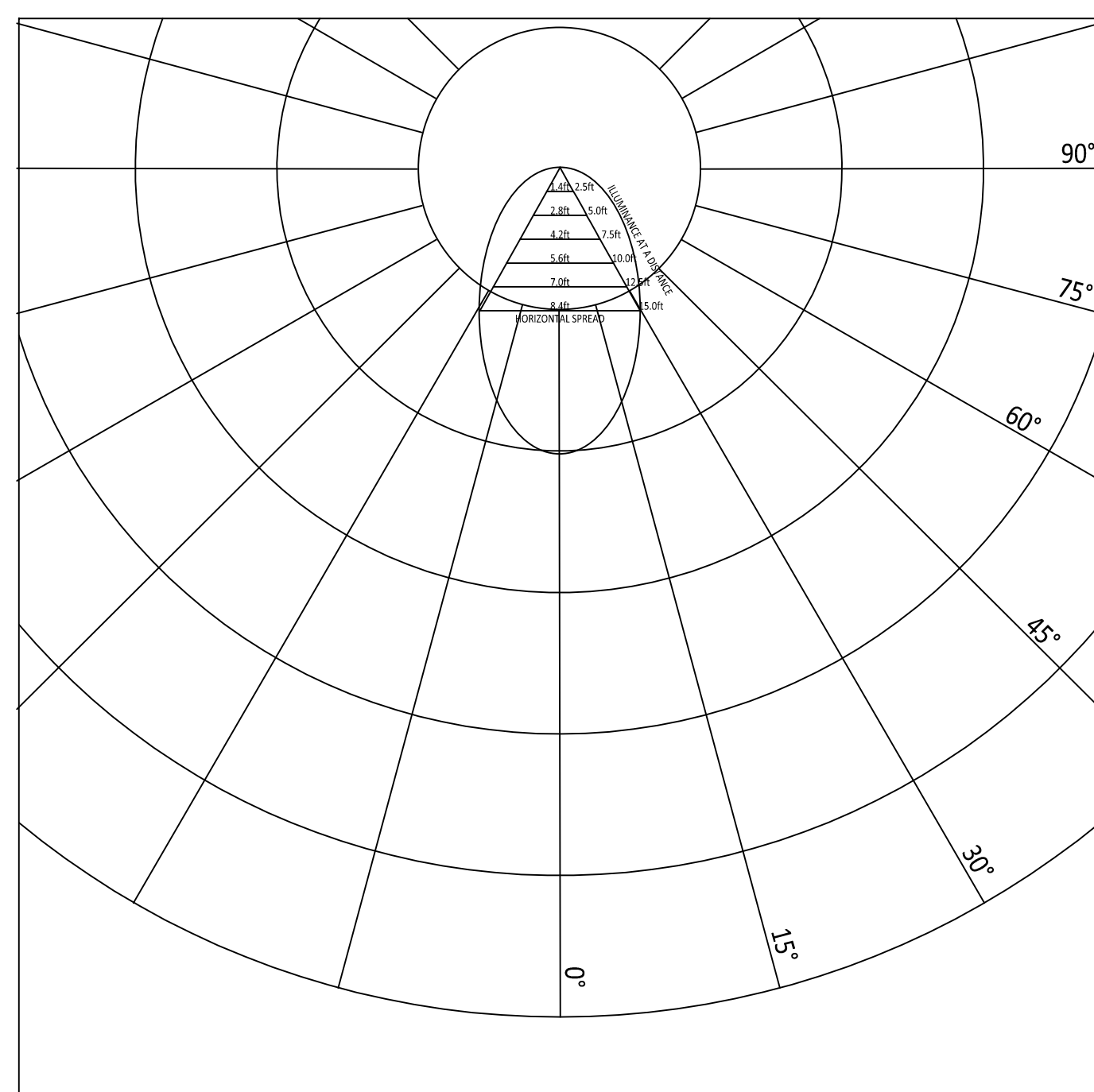

ILLUMINANCE AT A DISTANCE

DISTANCE	BEAM WIDTH
2.5FT	1.4FT
5.0FT	2.8FT
7.5FT	4.2FT
10.0FT	5.6FT
12.5FT	7.0FT
15.0FT	8.4FT

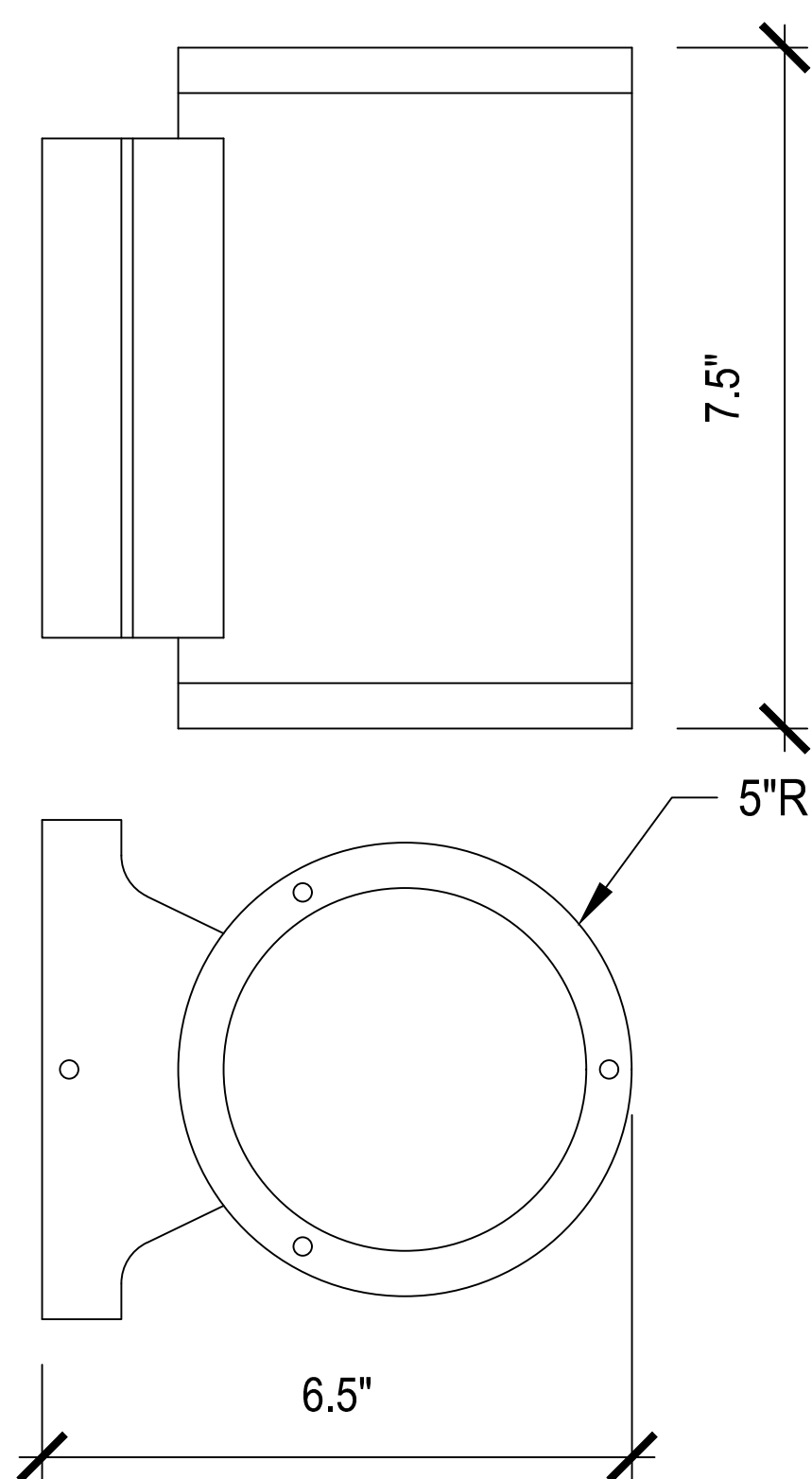

NOTE: SEE MANUFACTURER'S CUT SHEETS FOR DETAILS

REVISIONS

No.	Date	SYN.	Description

PHOTOMETRICS  
BUILDING EXTERIOR LIGHTING

LUCENTE HOLDINGS, INC.  
381 HAGADORN HILL RD.  
SPENCER, NY 14883

LUCENTE HOMES/VILLAGE SOLARS  
LANSEING (T) TOMPKINS CO. N.Y.

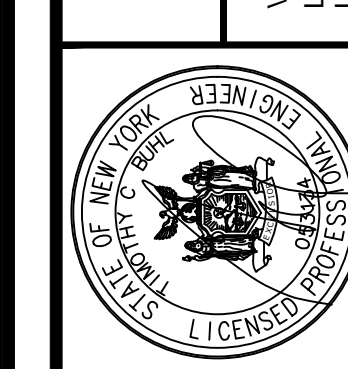

**TIMOTHY C. BUHL, P.E.**

35 FIRE LANE 24, AUBURN, NY 13021

DATE: JULY 11, 2022  
SCALE: N.T.S.  
DRAWN: SDG  
JOB:  
SHEET: **ST-10**



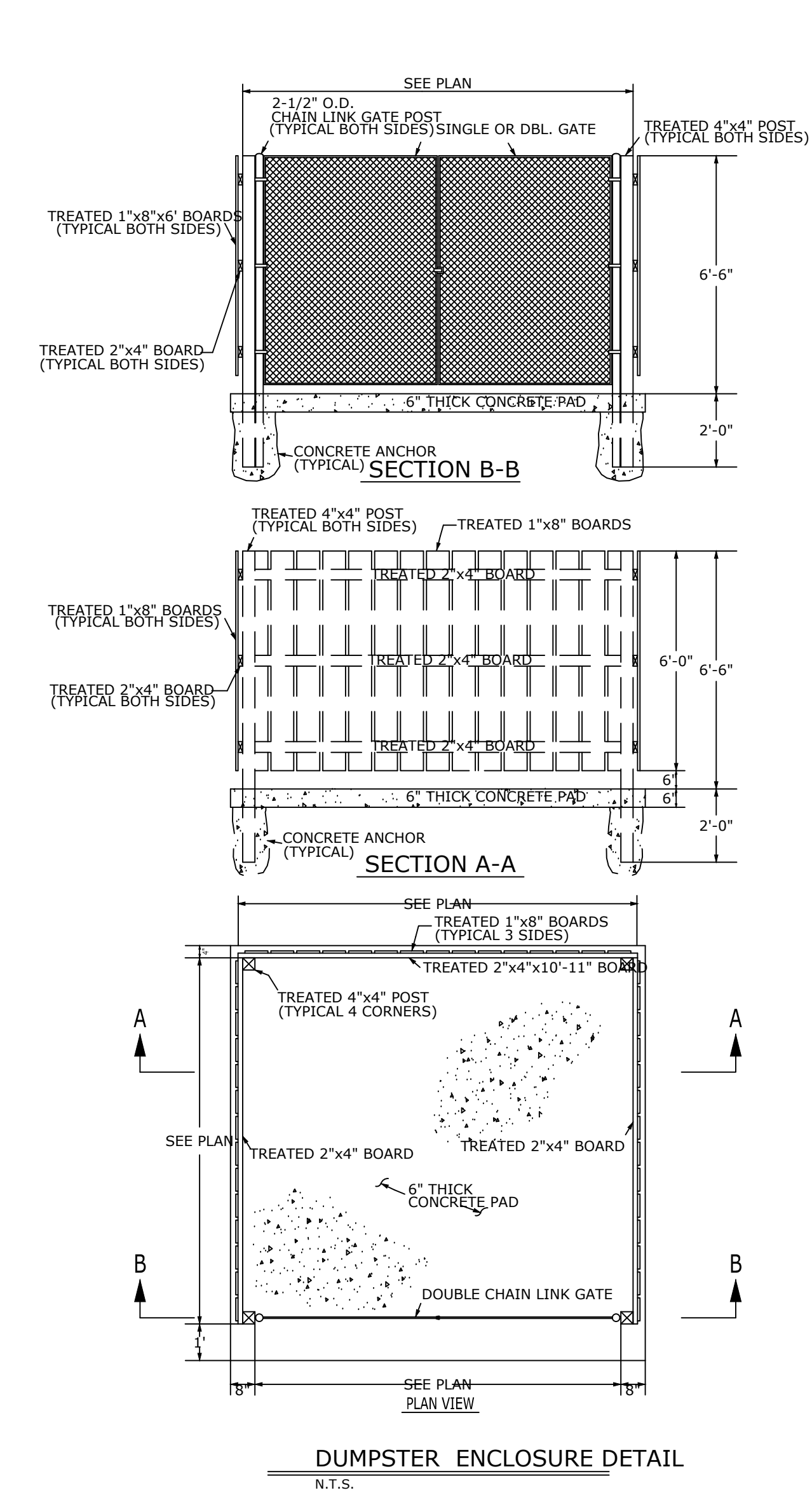
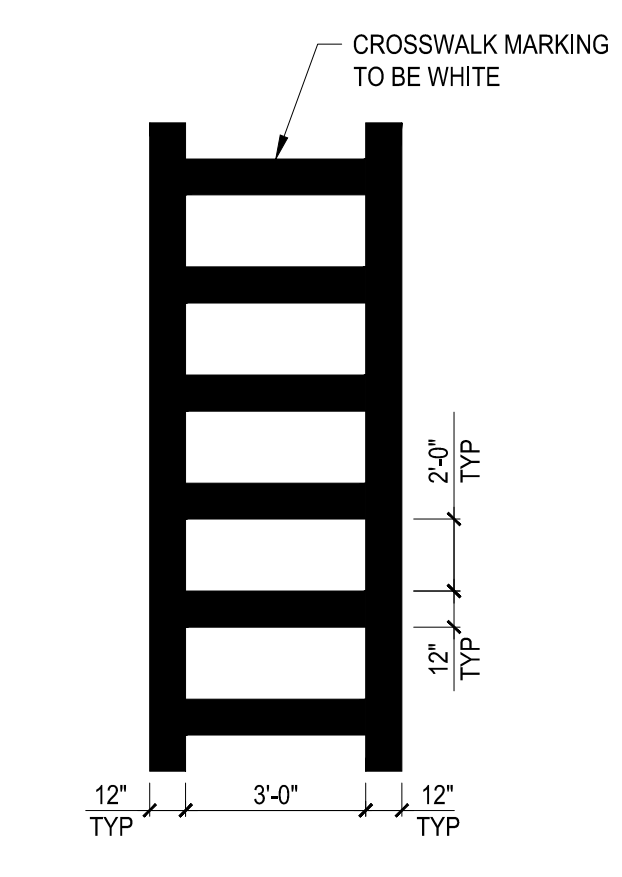
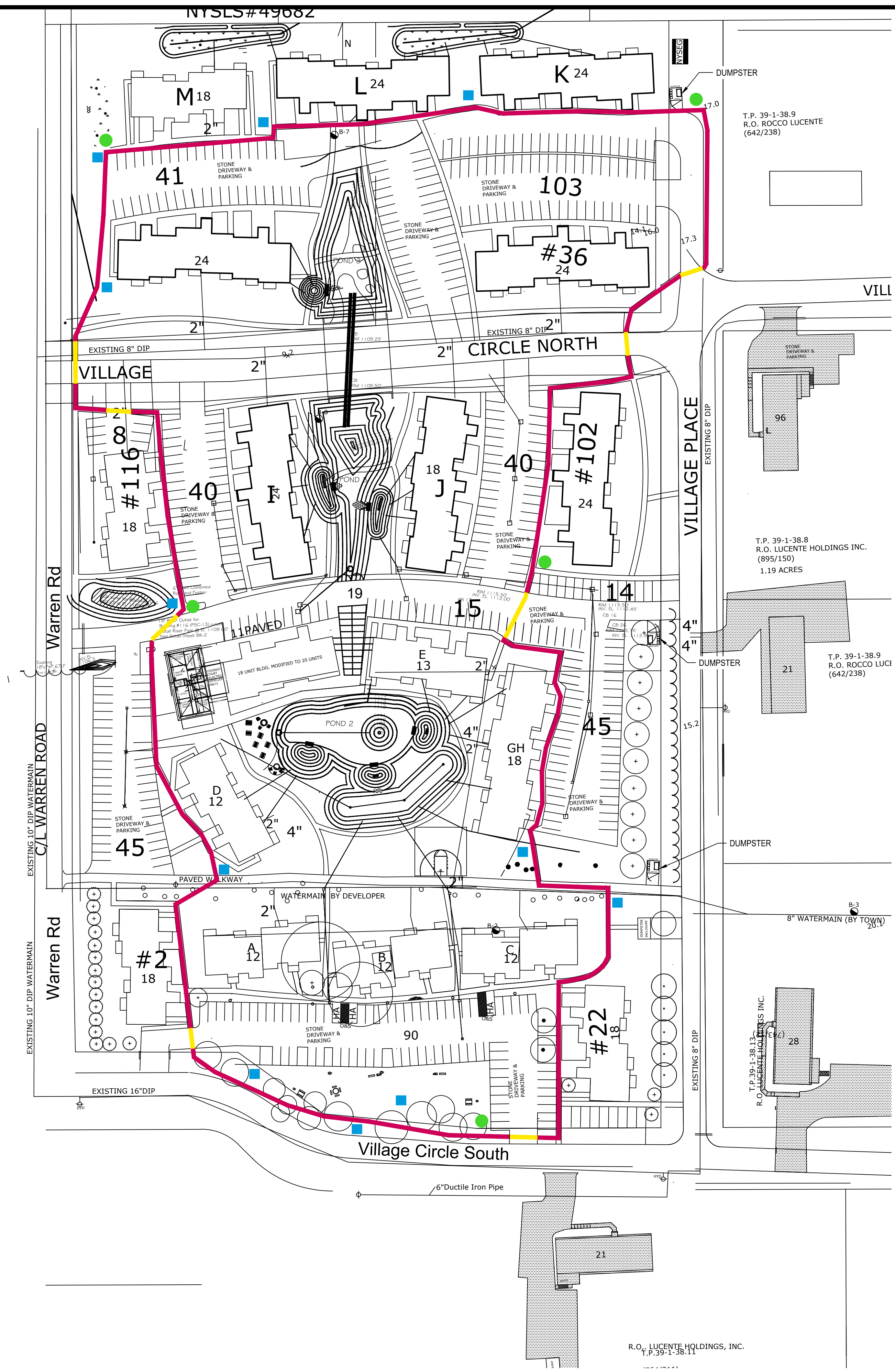

- LEGEND**
- FITNESS TRAIL
  - CROSSWALK
  - WAYFINDING
  - FITNESS STATION

REVISIONS	
No.	Description

**FITNESS TRAIL AND DUMPSTER LOCATIONS**

LUCENTE HOLDINGS, INC  
381 HAGADORN HILL RD.  
SPICER, NY 14883

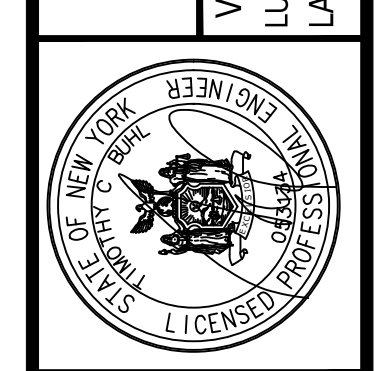

**TIMOTHY C. BUHL, P.E.**

35 FIRE LANE 24, AUBURN, NY 13021

DATE: JULY 11, 2022  
SCALE: 1"=60'  
DRAWN: JLB  
JOB:  
SHEET: ST-11



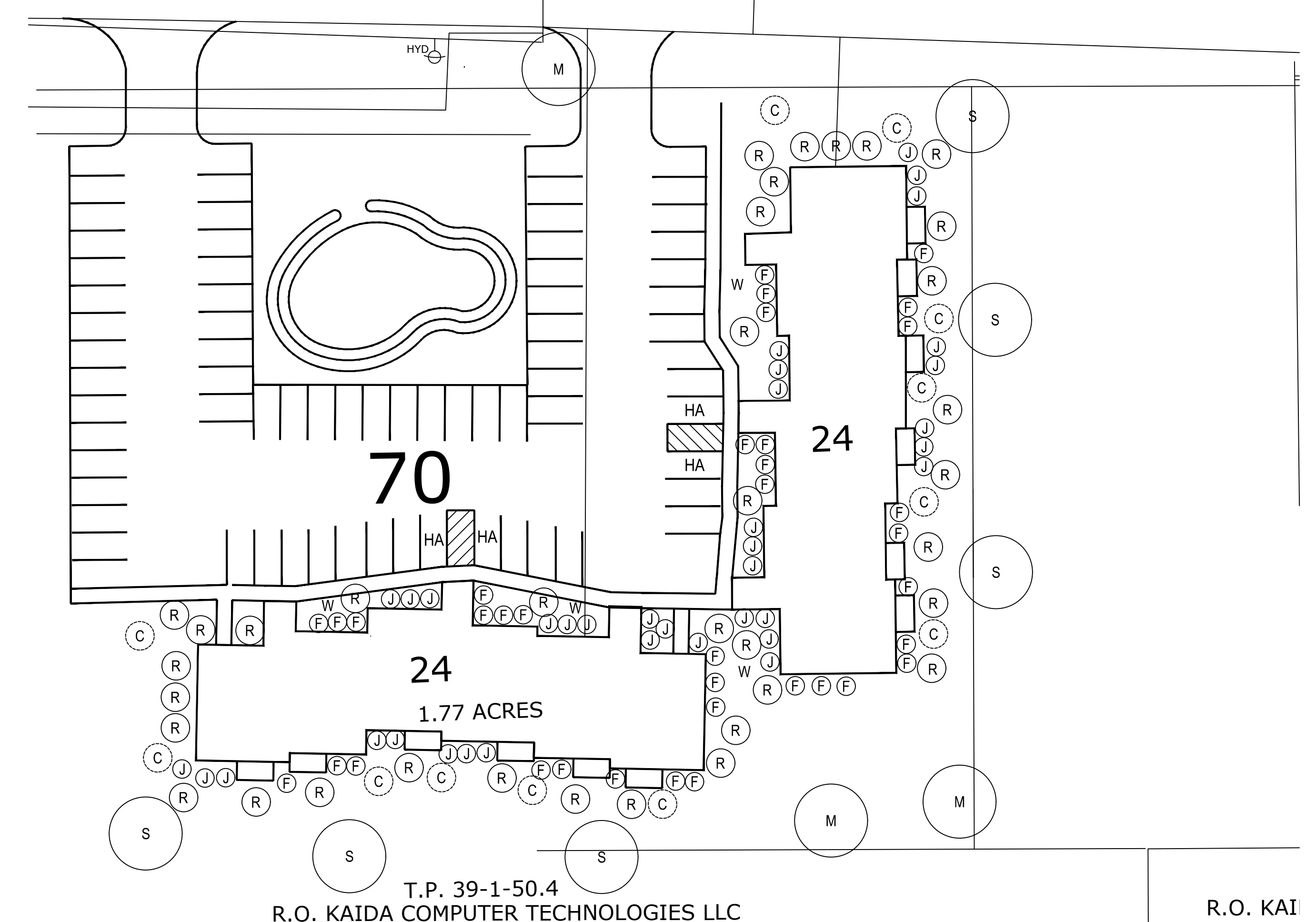
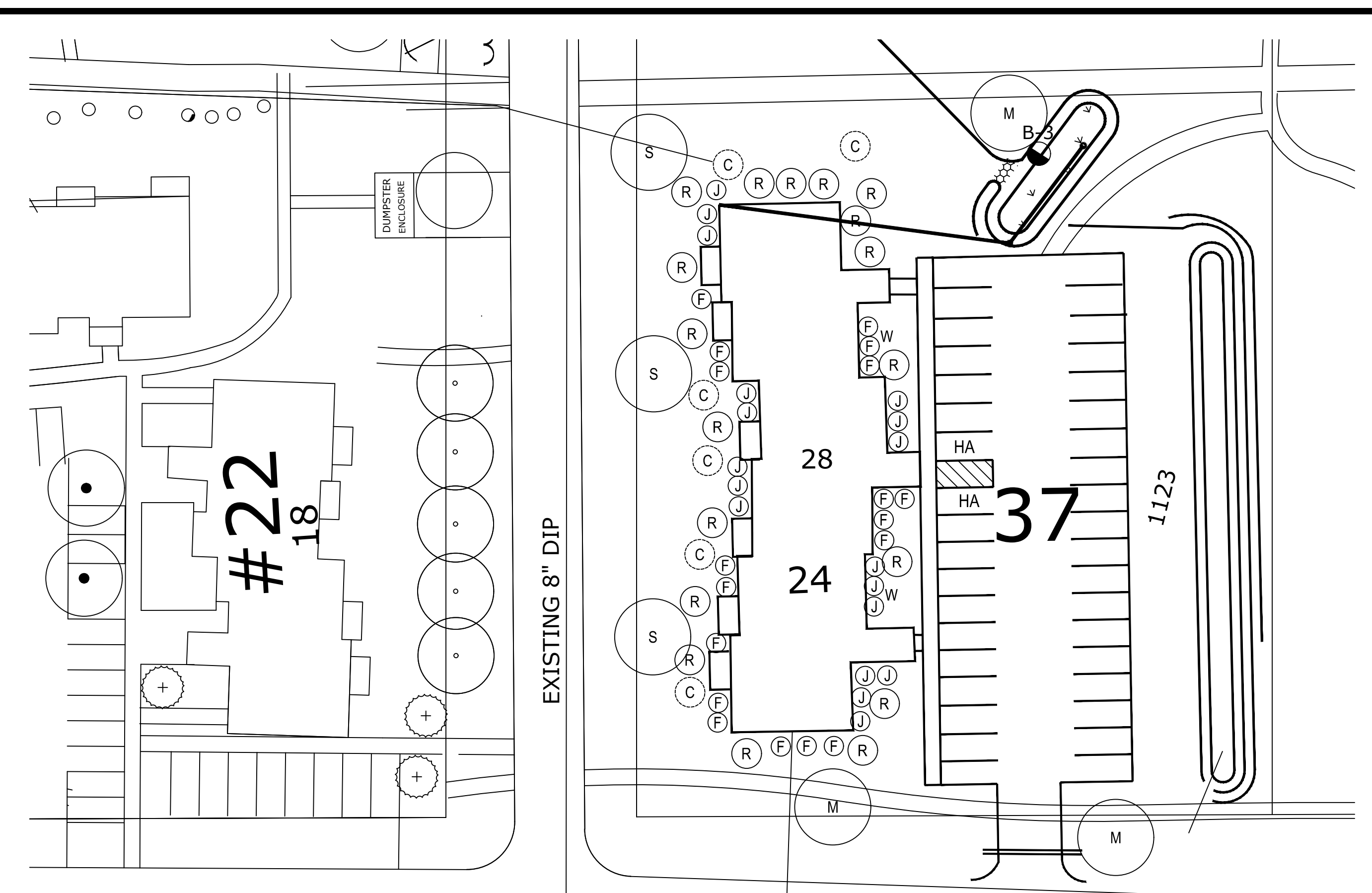
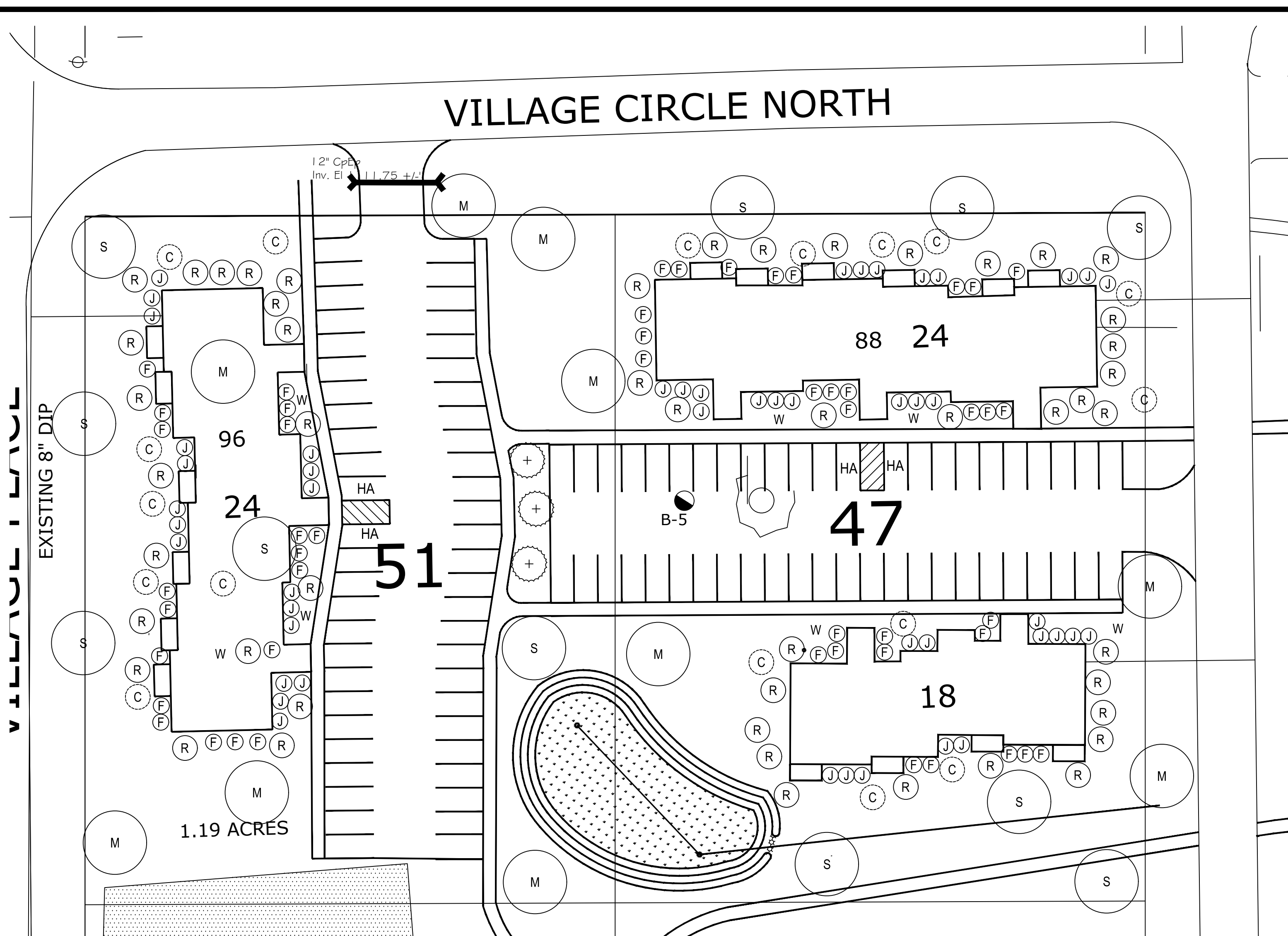

## PLANTING SCHEDULE

### 24 UNIT BUILDING PLANTINGS

PLANT TYPE	NUMBER OF PLANTS
FORSYTHIA SHRUBS	18 EA
JUNIPER SHRUBS	18 EA
ROSA SHARON SHRUBS	18 EA
WEeping CHERRY TREE	2 EA
CHERRY TREE	6 EA

### 18 UNIT BUILDING PLANTINGS

PLANT TYPE	NUMBER OF PLANTS
FORSYTHIA SHRUBS	12 EA
JUNIPER SHRUBS	12 EA
ROSA SHARON SHRUBS	12 EA
WEeping CHERRY TREE	2 EA
CHERRY TREE	4 EA

NOTE: SEE SUPPLEMENTAL LANDSCAPING CHART PREVIOUSLY SUBMITTED

<p>REVISIONS</p> <table border="1"> <thead> <tr> <th>No.</th> <th>Date</th> <th>SYM.</th> <th>Description</th> </tr> </thead> <tbody> <tr> <td> </td> <td> </td> <td> </td> <td> </td> </tr> </tbody> </table>		No.	Date	SYM.	Description				
No.	Date	SYM.	Description						
<p>PLANTING PLAN</p>									
<p>VILLAGE CIRCLE - PHASE 7 LUCENTE HOMES/VILLAGE SOLARS LANISING (T) TOMPKINS CO. N.Y.</p>									
<p>LUCENTE HOLDINGS, INC 381 HAGADORN HILL RD. SPICER, NY 14883</p>									
<p><b>TIMOTHY C. BUHL, P.E.</b> 35 FIRE LANE 24, AUBURN, NY 13021</p>									
<p>DATE: JULY 11, 2022 SCALE: 1"=60' DRAWN: JLB JOB: SHEET: <b>ST-12</b></p>									