

CHANGE ORDER NO.: 1

Owner:	Town of Landis	Owner's Project No.:	SRP-D-ARP-0201/25-05
Engineer:	Municipal Engineering, Inc.	Engineer's Project No.:	G22124
Contractor:	Maguire Iron, Inc.	Contractor's Project No.:	
Project:	100,000-gallon Elevated Water Tank		
Contract Name:	100,000-gallon Elevated Water Tank		
	Effective Date of Change		
Date Issued:	25 July 2025	Order:	25 July 2025

The Contract is modified as follows upon execution of this Change Order:

Description: **Adding a tubular corral on top of the water tower for a safety enclosure and potential future antenna mounts.**

Attachments: **Contractor's Change Proposal #1 - 30 June 2025, Sheets 100-4, 100-17, 100-18, 100-20.**

Change in Contract Price		Change in Contract Times <i>[State Contract Times as either a specific date or a number of days]</i>	
Original Contract Price: \$ 1,725,000.00	[Increase] [Decrease] from previously approved Change Orders No. 1 to No. N/A : \$ -0-	Original Contract Times: Substantial Completion: 15 January 2026 Ready for final payment: 14 February 2026	[Increase] [Decrease] from previously approved Change Orders No.1 to No. N/A : Substantial Completion: 0 days Ready for final payment: 0 days
Contract Price prior to this Change Order: \$ 1,725,000.00	[Increase] [Decrease] this Change Order: \$ -0-	Contract Times prior to this Change Order: Substantial Completion: 15 January 2026 Ready for final payment: 14 February 2026	[Increase] [Decrease] this Change Order: Substantial Completion: 30 days Ready for final payment: 30 days
Contract Price incorporating this Change Order: \$ 1,725,000.00		Contract Times with all approved Change Orders: Substantial Completion: 14 February 2026 Ready for final payment: 16 March 2026	

Recommended by Engineer (if required)

By: **Vincent J Tomaino** Digitally signed by Vincent J Tomaino
Date: 2025.07.25 13:33:49 -04'00'

Title: **Principal Project Engineer**

Date: **25 July 2025**

Accepted by Contractor

Project Manager

8.15.25

Authorized by Owner

By: _____

Title: _____

Date: _____

Approved by Funding Agency (not applicable)

By: _____

Title: _____

Date: _____

Contractor's Change Proposal #1 - 30 June 2025

CHANGE ORDER NO.: 1

Owner: Town of Landis Rowan County, NC
 Engineer: Municipal Engineering
 Contractor: Maguire Iron, Inc
 Project: Town of Landis - 100mg Tank
 Contract Name: 100,000 Gallon Water Tank
 Date Issued: 1/15/2025

Owner's Project No.: 25-05
 Engineer's Project No.: G22124
 Contractor's Project No.:

Effective Date of Change Order: 6/30/2025

The Contract is modified as follows upon execution of this Change Order: Description:

Adding a tubular coral on top of the water tower for a safety enclosure and future antenna mounts

Attachments:

Pages from Shop Drawings attached.

Change in Contract Price	Change in Contract Times [State Contract Times as either a specific date or a number of days]
Original Contract Price: \$ <u>1,725,000.00</u>	Original Contract Times: Substantial Completion: <u>1/15/2026</u> Ready for final payment: _____
[Increase] [Decrease] from previously approved Change Orders No. 1 to No. [Number of previous Change Order]: \$ _____	[Increase] [Decrease] from previously approved Change Orders No.1 to No. [Number of previous Change Order]: Substantial Completion: _____ Ready for final payment: _____
Contract Price prior to this Change Order: \$ <u>1,725,000.00</u>	Contract Times prior to this Change Order: Substantial Completion: <u>1/15/2026</u> Ready for final payment: _____
[Increase] [Decrease] this Change Order: \$ _____	[Increase] [Decrease] this Change Order: Substantial Completion: <u>3/2/2026</u> Ready for final payment: <u>4/1/2026</u>
Contract Price incorporating this Change Order: \$ <u>1,725,000.00</u>	Contract Times with all approved Change Orders: Substantial Completion: _____ Ready for final payment: _____

Recommended by Engineer (if required)

By: _____

Title: _____

Date: _____

Authorized by Owner

By: _____

Title: _____

Date: _____

Accepted by Contractor

Rafael Balayan

Project Manager

6/30/2025

Approved by Funding Agency (if applicable)

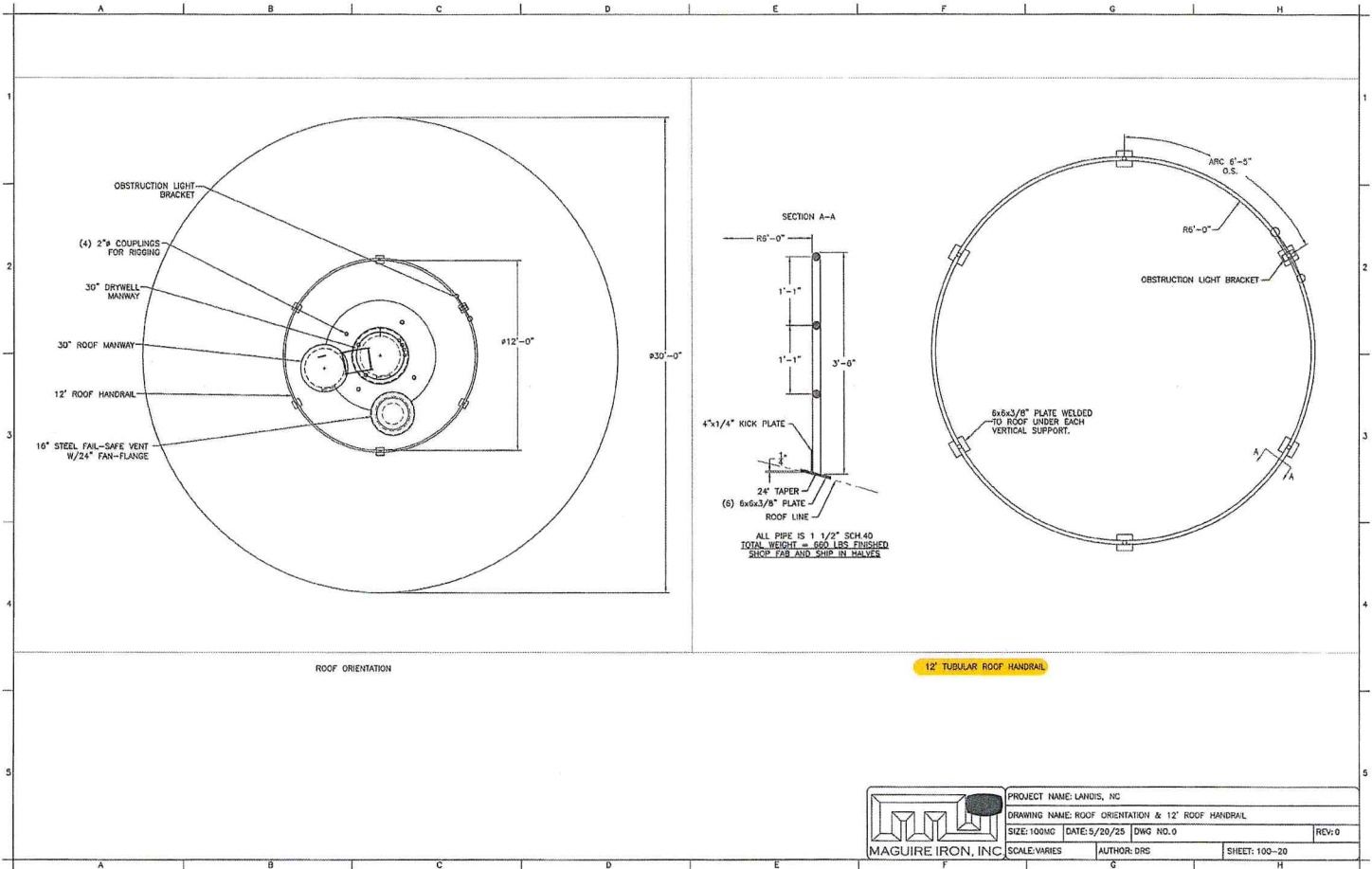

- OBSTRUCTION LIGHT BRACKET
- (4) 2" COUPLINGS FOR RIGGING
- 30" DRYWELL MANWAY
- 30" ROOF MANWAY
- 12' ROOF HANDRAIL
- 10" STEEL FAN-SAFE VENT W/24" FAN-FLANGE

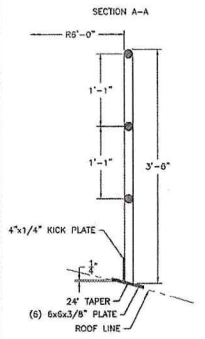

ALL PIPE IS 1 1/2" SCH 40
 TOTAL WEIGHT = 600 LBS FINISHED
 SHOP FAB AND SHIP IN PALLET

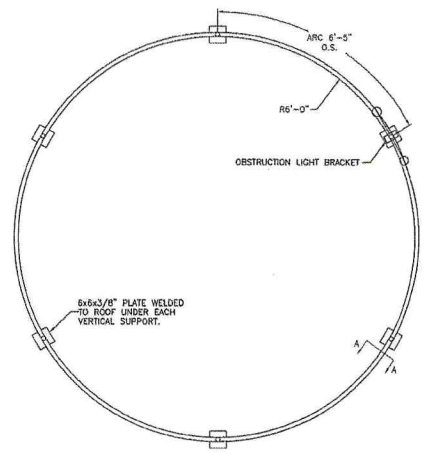

ROOF ORIENTATION

12' TUDULAR ROOF HANDRAIL

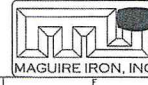

PROJECT NAME: LANDIS, NC			
DRAWING NAME: ROOF ORIENTATION & 12' ROOF HANDRAIL			
SIZE: 100MC	DATE: 9/20/25	DWG NO. 0	REV: 0
SCALE: VARIES	AUTHOR: DRS	SHEET: 100-20	

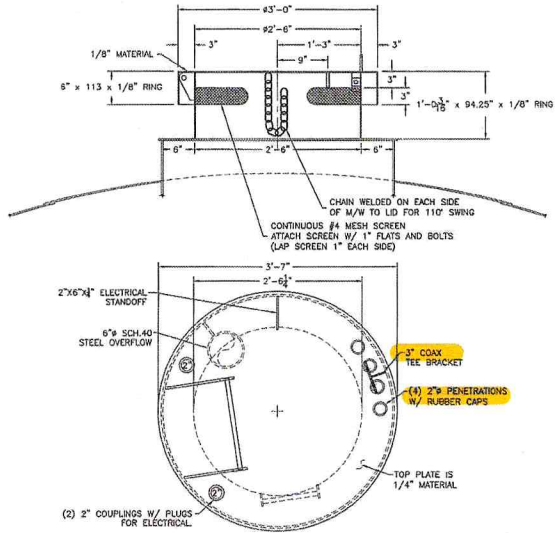
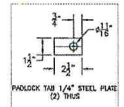
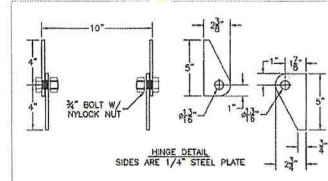
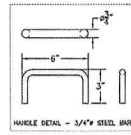
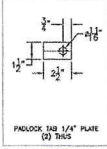
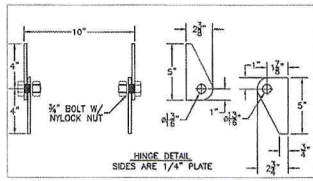
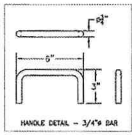

30" DRYWELL VENT/MANWAY

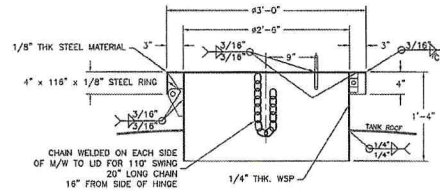
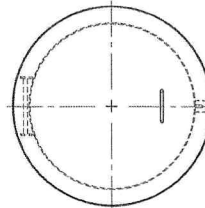

30" ROOF MANWAY



PROJECT NAME: LANDIS, NC
DRAWING NAME: ACCESS PATCHES
SIZE: 100MG DATE: 8/20/25 DWG NO. 0
SCALE: VARIES AUTHOR: DRS SHEET: 100-18

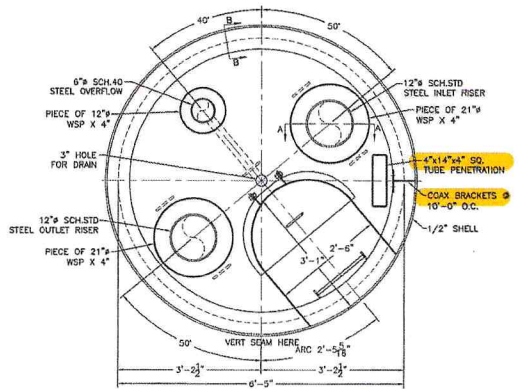
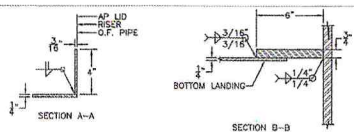

VIEW LOOKING DOWN
ONE ~ BOTTOM LANDING ~ THUS
APPROX. WT. 393# W/O CUTOUTS

ITEM OVERFLOW = 2'-0" RADIUS
RISERS = 2'-0"

NOTE: WELD (5) PADEYES UNDERSIDE OF LANDING 1'-0" ON EACH SIDE OF RISERS & (1) NEXT TO MANWAY FOR PAINTERS RIGGING

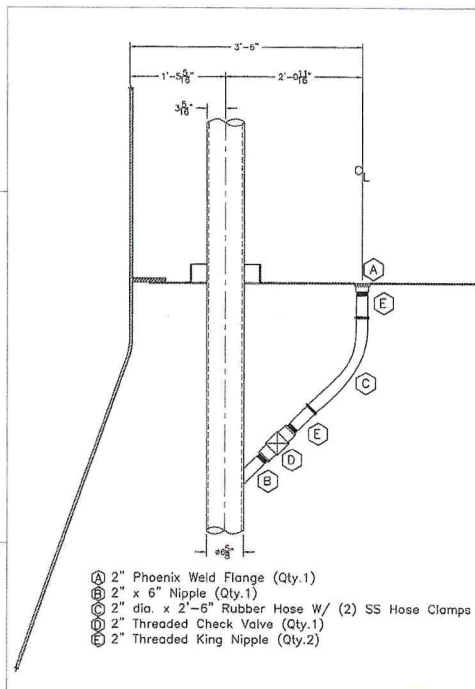
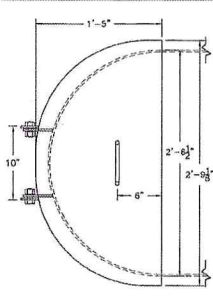

- (A) 2" Phoenix Weld Flange (Qty.1)
- (B) 2" x 6" Nipple (Qty.1)
- (C) 2" dia. x 2'-6" Rubber Hose W/ (2) SS Hose Clamps
- (D) 2" Threaded Check Valve (Qty.1)
- (E) 2" Threaded King Nipple (Qty.2)

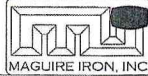

PROJECT NAME: LANDIS, NC			
DRAWING NAME: BOTTOM LANDING AND DRAIN ASSEMBLY			
SIZE: 100MG	DATE: 9/20/25	DWG NO. 0	REV: 0
SCALE: VARIES	AUTHOR: DRS	SHEET: 100-4	

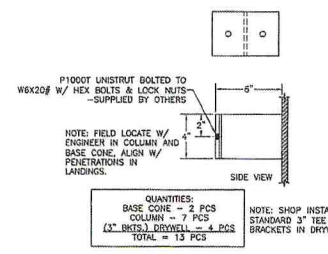
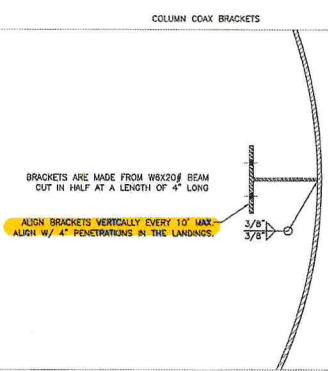
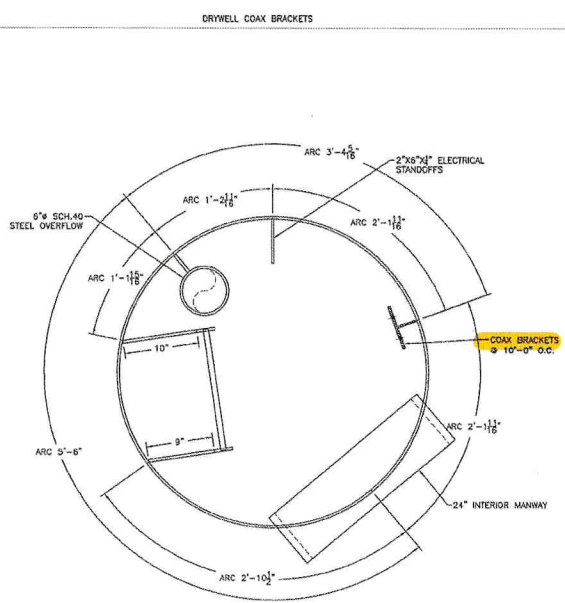

QUANTITIES	
BASE CONE	= 2 PCS
COLUMN	= 7 PCS
(3" BRKT) DRYWELL	= 4 PCS
TOTAL	= 13 PCS

NOTE: SHOP INSTALL STANDARD 3" TEE BRACKETS IN DRYWELL.

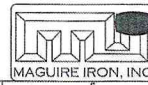

PROJECT NAME: LANDIS, NC	REV: 0
DRAWING NAME: COAXIAL CABLE BRACKETS	
SIZE: 100MMG	DATE: 5/20/25
SCALE: VARIES	AUTHOR: CRS
	SHEET: 100-17