

Change Order No. 3

Date of Issuance: 04/08/2026 Effective Date: Date Accepted by Owner

Project: Lincoln Street Improvement Project	Owner: State of Wyoming	Owner's Contract No.:E0624
Contract: Lincoln Street Improvement Project		Date of Contract: July 3, 2024
Contractor: High Country Construction		Engineer's Project No.: 17063

The Contract Documents are modified as follows upon execution of this Change Order:

Description:

WCD#8 was issued to clarify work on the 8th street irrigation crossing. It was discovered this work was shown in the plan set but not covered by a price in the Bid Schedule. Pricing was requested and provided on 3/25/26. Work commenced on 3/31.

Attachments (list documents supporting change):

3/17/26 WCD#8 cover sheet and irrigation plan sheets; HCC pricing letter dated 3/25/26.

CHANGE IN CONTRACT PRICE:

CHANGE IN CONTRACT TIMES:

Original Contract Price:

Original Contract Times: Working days Calendar days

\$ 7,296,256.80

Substantial completion (days or date): Oct. 31, 2025

Ready for final payment (days or date): Dec. 31, 2025

(Increase) [Decrease] from previously approved Change Orders No. 1 to No. 2:

(Increase) [Decrease] from previously approved Change Orders No. 1 to No. 2:

\$ 171,120.45

Substantial completion (days): 32 work days + winter

Ready for final payment (days): 32 work days + winter

Contract Price prior to this Change Order:

Contract Times prior to this Change Order:

\$ 7,467,377.25

Substantial completion (days or date): May 15, 2026

Ready for final payment (days or date): June 15, 2026

(Increase) [Decrease] of this Change Order:

[Increase] [Decrease] of this Change Order:

\$ 35,456.60

Substantial completion (days or date): 0

Ready for final payment (days or date): 0

Contract Price incorporating this Change Order:

Contract Times with all approved Change Orders:

\$ 7,502,833.85

Substantial completion (days or date): May 15, 2026

Ready for final payment (days or date): June 15, 2026

RECOMMENDED:

ACCEPTED:

ACCEPTED:

By: [Signature]
Engineer (Authorized Signature)

By: _____
Owner (Authorized Signature)

By: _____
Contractor (Authorized Signature)

Date: 4/8/26

Date: _____

Date: _____

Approved by Funding Agency (if applicable):

Date: _____

This page intentionally left blank.

-End of Section-

Work Change Directive

No. 8

Date of Issuance: 3/17/26 Effective Date: 3/17/26

Project: Lincoln Street Improvements	Owner: City of Lander	Owner's Contract No.: E0624
Contract: Lincoln Street Improvement Project		Date of Contract: July 3, 2024
Contractor: High Country Construction		Engineer's Project No.: 17063

Contractor is directed to proceed promptly with the following change(s):

Description:

- 1) Add (3) sewer services and (4) water services on 600 block. - To be paid according to CO#2 Pricing. These services were already counted in CO#2, but not yet delineated.
- 2) Adjust dimensions and/or relocate two (2) approaches on 800 block. – To be paid under bid unit price items 9,21,24,25,& 26 per field measured quantities.
- 3) Install irrigation box and pipe components according to clarifications detailed in attached revisions. – Notify engineer of any expected changes in price.

Attachments (list documents supporting change):

Sheets w/ Revisions marked: 3A, 3B, 3C, 3D, P-6, P-8, P-9, C-106, D-10



Purpose for Work Change Directive:

Authorization for Work described herein to proceed on the basis of Cost of the Work due to:

- Nonagreement on pricing of proposed change.
- Necessity to expedite Work described herein prior to agreeing to changes on Contract Price and Contract Time.

Estimated change in Contract Price and Contract Times:

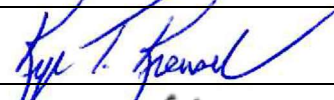
Contract Price \$ TBD (increase/ Contract Time _____ (increase/
decrease) days decrease)

Recommended for Approval by Engineer:		Date	<u>3/17/26</u>
Authorized for Owner by:		Date	<u>3/19/2026</u>
Received for Contractor by:		Date	
Received by Funding Agency (if applicable):		Date:	

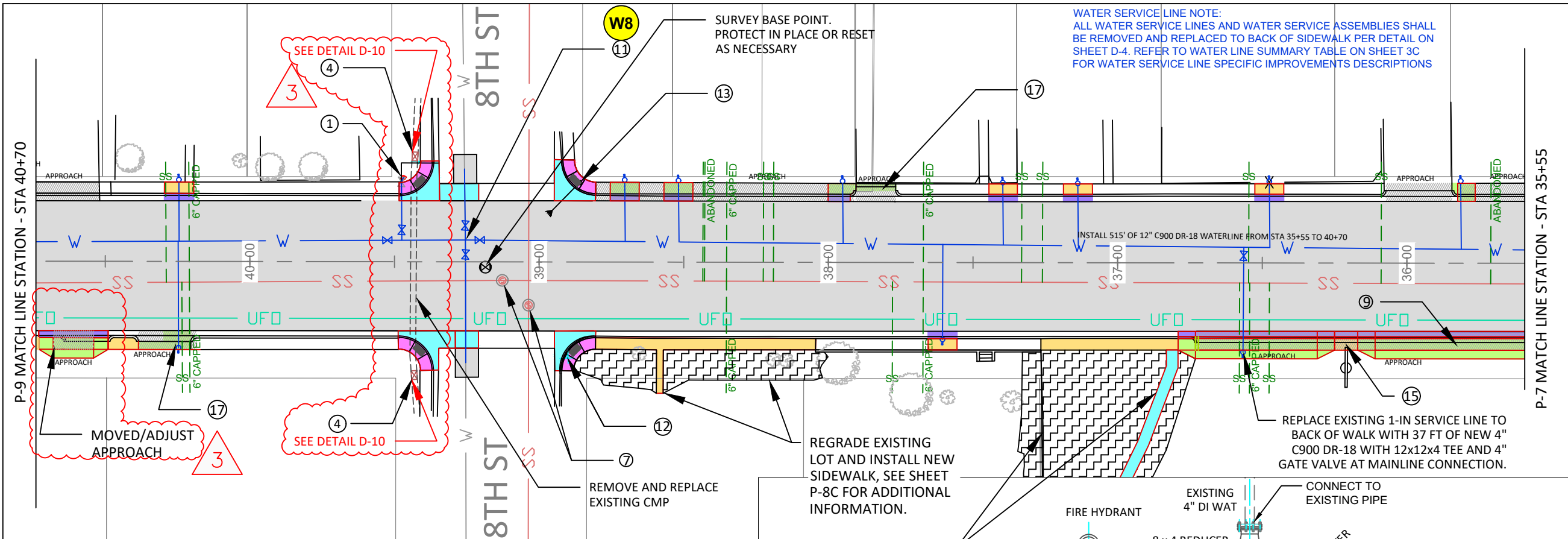

WATER SERVICE LINE NOTE:
 ALL WATER SERVICE LINES AND WATER SERVICE ASSEMBLIES SHALL BE REMOVED AND REPLACED TO BACK OF SIDEWALK PER DETAIL ON SHEET D-4. REFER TO WATER LINE SUMMARY TABLE ON SHEET 3C FOR WATER SERVICE LINE SPECIFIC IMPROVEMENTS DESCRIPTIONS

WHS
 ENGINEERING & SURVEYING & PLANNING
 1515 9th Street, Suite A | Rock Springs, WY 82901
 Phone 307-362-6065 | Fax 307-362-6064

CITY OF LANDER
 240 LINCOLN STREET
 LANDER, WY 82520

NOTES:

- ① REMOVE AND REPLACE HYDRANT ASSEMBLY COMPLETE, SEE DETAIL ON SHEET D-4.
- ② LOCATION OF WATER SERVICE UNKNOWN, REMOVE AND REPLACE WATER SERVICE ASSEMBLY COMPLETE TO BACK OF SIDEWALK, SEE DETAIL ON SHEET D-4.
- ④ REMOVE & REPLACE EXISTING CATCH BASIN.
- ⑦ ALL EXISTING MANHOLES SHALL BE ADJUSTED TO MATCH PROPOSED FINISHED GRADE. INSTALL NEW CONCRETE COLLARS AS NECESSARY, SEE DETAIL SHEET C-501.
- ⑪ REMOVE AND REPLACE 8" WATER LINE AND ALL APPURTENANCES WITH 12", SEE INSET FOR INTERSECTION DETAILS.
- ⑫ REMOVE AND RELOCATE EXISTING SIGN POST, SEE DETAIL ON SHEET D-9.
- ⑬ PROTECT EXISTING SIGN AND / OR POWER POLE. COORDINATE RELOCATIONS WITH CITY OF LANDER.
- ⑭ PROPOSED SANITARY SEWER REALIGNMENT, SEE SHEETS C-101 TO C-110.
- ⑮ REMOVE EXISTING APPROACH AND REPLACE W/ CURB, GUTTER & SIDEWALK, SEE DETAILS ON SHEET D-1
- ⑯ REPLACE APPROACH TO MATCH EXISTING, SEE VALLEY GUTTER APPROACH DETAIL ON SHEET D-2.
- ⑰ PROTECT & RETAIN EXISTING VALLEY GUTTER APPROACH.
- ⑱ REMOVE ELECTRICAL PULL BOX AND RESET AS REQUIRED.

	EXISTING CONCRETE SIDEWALK & APPROACH
	AREA OF PAVEMENT TO BE REPLACED
	CONSTRUCT NEW CONCRETE SIDEWALK, SEE DETAILS ON SHEET D-1
	CONSTRUCT NEW CONCRETE VALLEY GUTTER, SEE DETAILS ON SHEET D-1
	CONSTRUCT NEW HANDICAP RAMP, SEE DETAILS ON SHEET D-3
	CONSTRUCT NEW CONCRETE APPROACH, SEE DETAILS ON SHEET D-2
	CONSTRUCT NEW CONCRETE HIGH BACK CURB AND GUTTER, SEE DETAILS ON SHEET D-1



REGRADE PARKING LOT TO MATCH NEW SIDEWALK. DISPOSE OF EXCESS MATERIAL OFFSITE (APPROXIMATELY 150 CY OF MATERIAL). INSTALL NEW CONCRETE VALLEY GUTTER, SEE SHEET P-8B FOR ADDITIONAL INFORMATION.

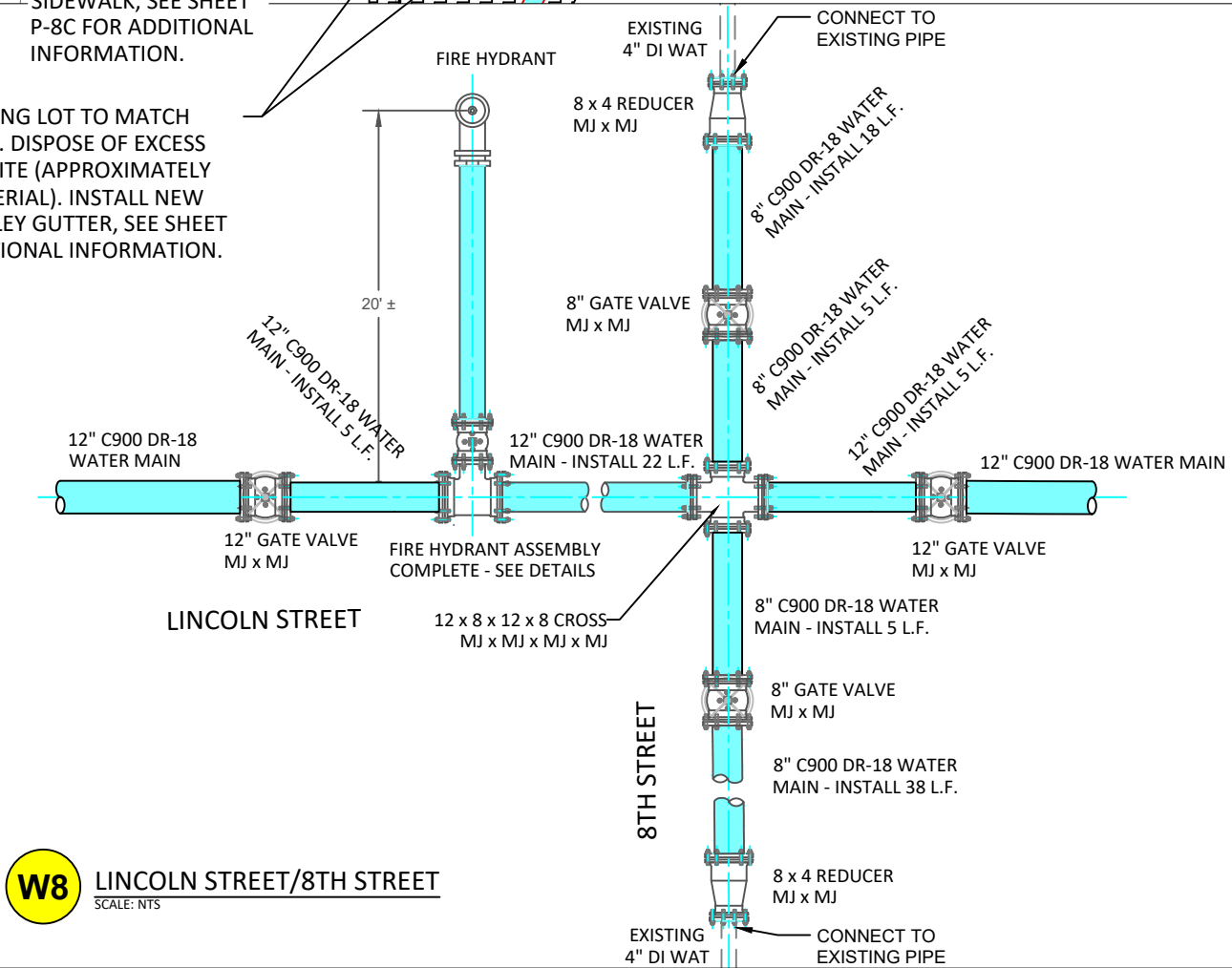

W8 LINCOLN STREET/8TH STREET
 SCALE: NTS

REV: - WCD#8

DATE: 03/17/2026

CITY OF LANDER

**LINCOLN STREET WATER REPAIR
 STREET RECONSTRUCTION PROJECT
 PLAN SHEET - STA 35+00 TO 40+00**

PROJECT NO.: +17063

DRAWN BY: MT
 REVIEWED BY: KTK

SHEET NO. **P-8**

- NOTES: (REFERS TO SINGLE AND DOUBLE CATCH BASINS)
- CATCH BASIN GRATE SHALL BE D & L I-3517 OR D & L I-3519 OR APPROVED EQUAL.
 - GROUT ALL PENETRATIONS. PIPES SHALL BE CUT SMOOTH WITHIN 2 INCHES OF CATCH BASIN INNER WALL.
 - KNOCK-OUTS SHALL BE AT LEAST 6 INCHES LARGER IN DIAMETER THAN OUTSIDE DIAMETER OF PROPOSED PIPE LINE MATERIAL.
 - REINFORCING SHALL BE PER PRECAST MANUFACTURER, LIVE LOADING SHALL BE MINIMUM ASSHTO HS-20 LOADING.
 - FOR BOXES WIDER THAN 24", INSTALL HSS 6x6x3/8 SET IN CONCRETE POCKETS. STEEL SHALL BEAR ON MINIMUM OF 6" WIDE CONCRETE. INLET FRAMES SHALL BEAR EQUALLY ON STEEL.

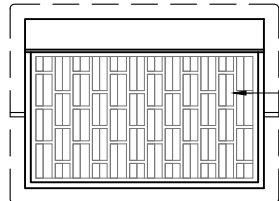

D & L I-3517 (VANED GRATE)	D & L I-3519 (SUMP GRATE)
P-8 (2)	P-5B (2) CB-1 & CB-2

SEE SHEET D-12 FOR ADDITIONAL INFORMATION RELATED TO THE CATCH BASINS ON SHEET P-5B

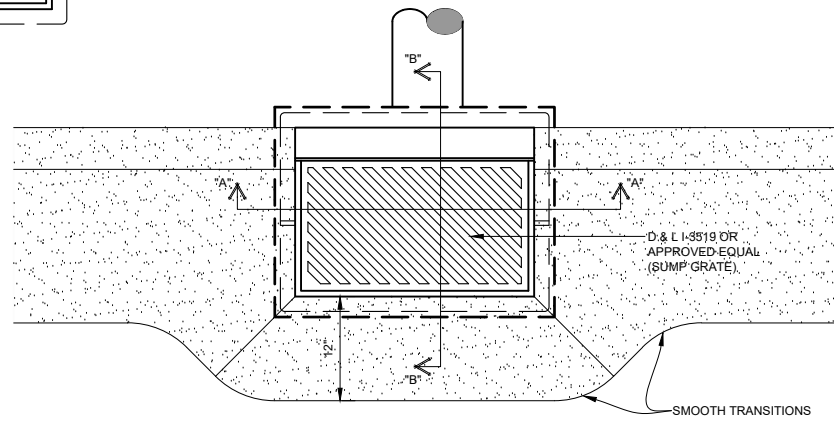

PLAN

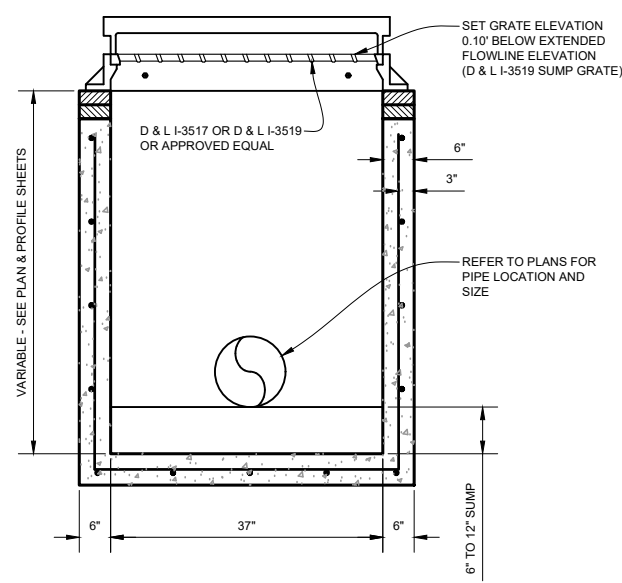

SECTION "A"

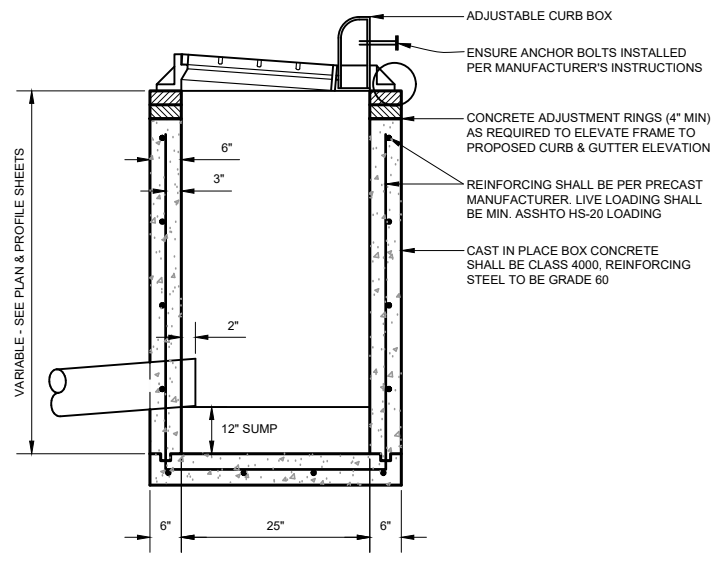

SECTION "B"

INLET/CATCH BASIN - (FOR CURB AND GUTTER SECTION)
SCALE: NTS

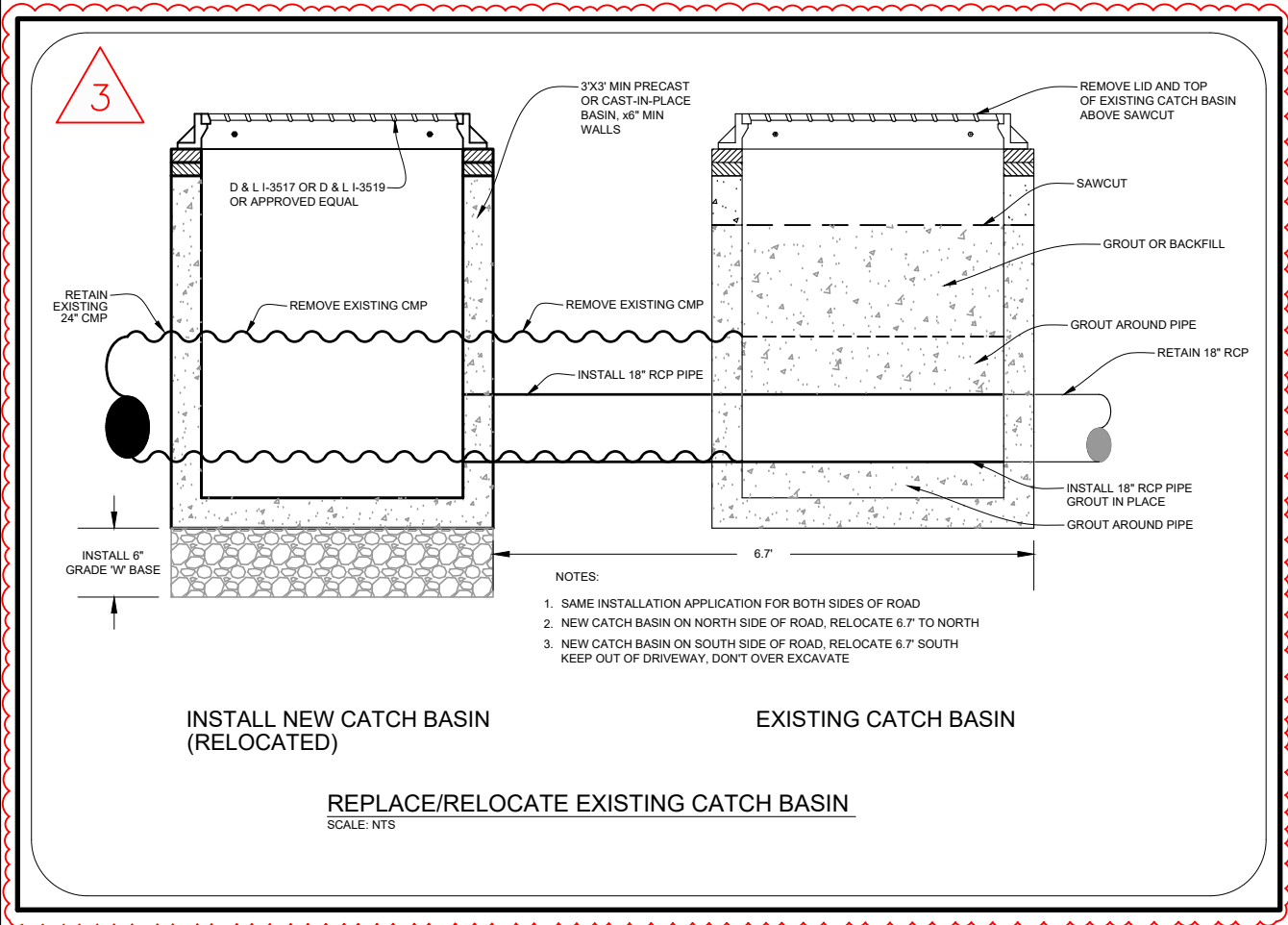



High Country Construction
Lander, Wyoming
307-332-4933

March 25, 2026

WHS

Attn : Kye T Kreusel

205 County Rd 128A Suite 400

Cheyenne, WY 82007

RE: 8th & Lincoln Street Irrigation Replacement
Lincoln Street project

Dear Kye,

High Country Construction is providing this quote for work associated with the replacement of the existing RCP culvert and two cast in place boxes located at the 8th and Lincoln Street intersection on the West side. Proposed cost for the work and all associated tasks is as follows:

- Demolition and Removal of existing RCP & cast in place boxes - \$3772.00
- Replacement of RCP with 24-inch CMP - \$16,776.00
 - Includes 24-inch CMP
 - Includes Flowable Fill over the length of pipe
 - Includes Watertight bands for CMP
- Ellis Concrete to place 2 new cast in place boxes cast around the pipe - \$14,908.60

TOTAL COST - \$35,456.60

As part of this proposal, High Country Construction is also asking for two additional construction days be added. One day is asked for the removal and installation of pipe, and one day for preparation and completion of the cast in place boxes.

Sincerely,

Nicholas Newman

Nick Newman

Project Manager
High Country Construction, Inc.