



WATER UTILITIES DEPARTMENT
301 COLLEGE STREET
LAKE WORTH BEACH, FL 33460
561.586.1710

CHANGE ORDER

Project Number: SG1804 **Contractor:** R&D Paving, LLC

Project Name: Boutwell Road Lake Worth Park of Commerce – Phase II

Change Order Number: 03

Change Order Effective Date: 06/1/2021 **Contractor Phone:** (561)588-6681

Change Order Type: Price and Time **Existing Purchase Order Number:** 183518

Description of Change:

To repair the current swale drainage overflow at Corona St. just south of 7th Ave., City of Lake Worth Beach decided to connect a new swale structure to the new S-54 structure. Therefore, the City of Lake Worth Beach negotiated with the Contractor for the additional costs to install new swale structure, connecting pipe work and restoration.

1	2	3	4	5	6
Item No.	Description	Qty	Unit	Unit Price	Increase in Contract Price
DM-1	Clearing and Grubbing, Inc. Asphalt and Base)	0.080	AC	\$19,626.00	\$1,570.08
R-1	Regular Excavation	47.000	CY	\$11.00	\$517.00
D-8	Connect to Existing Structure	1.000	EA	\$2,090.00	\$2,090.00
R-5	12" Rock Base Course (2 Lifts)	45.800	SY	\$22.40	\$1,025.92
R-6	12" Stabilized Subgrade	45.800	SY	\$11.05	\$506.09
R-2	Superpave Asphaltic Concrete 1-1/2" SP 12.5	33.500	TN	\$138.00	\$4,623.00
R-3	Superpave Asphaltic Concrete 1" SP 9.5	22.300	TN	\$125.00	\$2,787.50
425-1-551	Inlet - Drainage: Ditch Bottom Type E	1.000	EA	\$5,376.69	\$5,376.69
D-9	RCP, Round, 18" S/CD	158.000	LF	\$210.00	\$33,180.00
L-9	Sod, Bahia	25.000	SY	\$5.45	\$136.25
D-5	Type P-7 Manhole	1.000	EA	\$8,140.00	\$8,140.00
Total Amount:					\$ 59,952.53

Price of Original Contract: \$ 2,533,028.77 (authorized by Commission on June 16, 2020
Agenda Item (Consent Agenda)

Current Price of Contract (including Change Orders): \$ 2,539,541.76

Price of Current Change Order: \$ 59,952.53

New Contract Price: \$ 2,599,494.29

Basis of Price Change: Unit Price Time & Material Lump Sum

Contract Time Change

No Change Extended Decreased by 12 work days

The CONTRACTOR and the OWNER agree that this CHANGE ORDER represents the complete agreement of the parties with respect to these matters as of the date of this CHANGE ORDER. By approving this Change Order, the CONTRACTOR releases any and all claims that it may have against the OWNER under the subject contract including, but not limited to claims for equitable adjustments, which occurred or accrued prior to the effective date of this CHANGE ORDER.

This Change Order may be executed in counterparts and is not effective until approved by either the City Manager or City Commission (as designated on the last page of this Change Order).

Reviewed and Accepted by: R&D Paving, LLC
(Contractor Name)

Contractor Representative (Signature)

Managing Member 4/21/2021
Title Date



Approved by:

_____ (Water Department Director)

_____ (Date)

IN WITNESS WHEREOF, the OWNER/CITY has approved this
Change Order No. 03 to the SG1804 Project on
_____, 20__.

CITY OF LAKE WORTH BEACH, FLORIDA

ATTEST:

By: _____
Deborah M. Andrea, City Clerk

By: _____
Betty Resch, Mayor

APPROVED AS TO FORM AND
LEGAL SUFFICIENCY:

APPROVED FOR FINANCIAL
SUFFICIENCY

By: _____
Glen J. Torcivia, City Attorney

By: _____
Bruce T. Miller, Financial Services Director

CONTRACT MODIFICATION (CHANGE ORDER)

City of Lake Worth Beach
 1749 3rd Avenue South
 Lake Worth, FL 33460

Project Name: Boutwell Road Lake Worth Park of Commerce – Phase II
Project Number: G1J19
FM Number: 442094-1-58-01
Owner: City of Lake Worth Beach
Contractor: R&D Paving, LLC

Contract No. #: SG1804
Date: 3/25/2021

Change Order No. #: 3

The following modifications to the CONTRACT are hereby ordered:

Item No. 01

To repair the current swale drainage overflow at Corona St. just south of 7th Ave., City of Lake Worth Beach decided to connect a new swale structure to the new S-54 structure. Therefore, the City of Lake Worth Beach negotiated with the Contractor for the additional costs to install new swale structure.

Change Order No. 01 involves the following additions / deductions to the Original Contract:

Item	Description	Quantity	Unit	Unit Price	Amount	Add/Delete
1	Installation of new swale structure	1	LS	\$ 59,952.53	\$ 59,952.53	Add
Total					\$ 59,952.53	

Change order No. 01 results in a net change to the Contract in the amount of

\$ 59,952.53

<u>Contract Amount</u>	<u>Contract Time (Calendar Days)</u>
Original \$ 2,533,028.77	Original Contract Time 270
Previous Changes (+/-) \$ 6,512.99	Previous Change (+/-) 0
This Change Order (+/-) \$ 59,952.53	This Change Order (+/-) 12
Revised Contract Amount \$ 2,599,494.29	Revised Contract Time 282

Original Contract Completion Date 5/13/2021

Revised Contract Completion Date 5/25/2021

OWNER	CONTRACTOR	ENGINEER
	<i>R&D PAVING LLC</i>	<i>AE Engineering Inc.</i>

 Digitally signed
 by Felipe Lofaso
 Date: 2021.04.21
 06:44:04 -04'00'

Date: _____

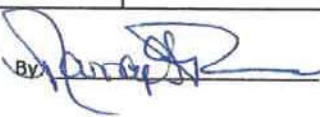
By: 
 Date: 4-6-21

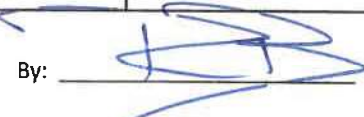
By: 
 Date: 4-8-21

FDOT Reviewed by and Signature:



Date: 4/20/2021

for concurrence without participation

Engineer's Estimate Summary - Change Order No. 01

Contract No.:

SG1804

County

Palm Beach County

Description

Boutwell Road Lake Worth Park of Commerce – Phase II

Item	Description	No. of Days
1	Additional days needed to repair the current swale drainage overflow at corona street	12
Total Days Granted:		12 days

Item	Description	Amount	FDOT Participating
1	Installation of new swale structure	\$59,952.53	
Total Amount for this Change Order:		\$59,952.53	

ENGINEER'S ESTIMATE/ BASIS FOR ESTIMATE

Contract No.: SG1804
County Palm Beach County
Description Boutwell Road Lake Worth Park of Commerce – Phase II

Issue: Installation of new swale structure

<u>Description:</u>					
To repair the current swale drainage overflow at Corona St. just south of 7th Ave., City of Lake Worth Beach decided to connect a new swale structure to the new S-54 structure. Therefore, the City of Lake Worth Beach negotiated with the Contractor for the additional costs to install new swale structure.					
<u>Engineer's Estimate:</u>					
Item	Description	Qty	Unit	Unit Price	Amount
DM-1	Clearing and Grubbing (Inc. Asphalt and Base)	0.08	AC	\$19,626.00	\$1,570.08
R-1	Regular Excavation	47.00	CY	\$11.00	\$517.00
D-8	Connect to Existing Structure	1.00	EA	\$2,090.00	\$2,090.00
R-5	12" Rock Base Course (2 Lifts)	45.80	SY	\$22.40	\$1,025.92
R-6	12" Stabilized Subgrade	45.80	SY	\$11.05	\$506.09
R-2	Superpave Asphaltic Concrete 1-1/2" SP 12.5	33.50	TN	\$138.00	\$4,623.00
R-3	Superpave Asphaltic Concrete 1" SP 9.5	22.30	TN	\$125.00	\$2,787.50
425-1551	Inlet - Drainage: Ditch Bottom Type E	1.00	EA	\$5,376.69	\$5,376.69
D-9	RCP, Round, 18" S/C/D	158.00	LF	\$210.00	\$33,180.00
L-9	SOD, Bahia	25.00	SY	\$5.45	\$136.25
D-5	Type P-7 Manhole	1.00	EA	\$8,140.00	\$8,140.00
Total Amount of Engineer's Estimate:					<u>\$59,952.53</u>

Basis of Estimate:

This cost was derived by implementing contract unit price for all the existing pay items in the contract and Statewide Averages for all the non-existing Pay Items in the contract.

Ricardo Baraybar
Digitally signed by Ricardo Baraybar
 DN: CN=Ricardo Baraybar,
 OU=A01410C0000016E1CBDD40E0000A9F2,
 O=Unaffiliated, C=US
 Date: 2021.03.25 17:28:03-04'00'

3/25/2021

Ricardo Baraybar, P.E.
 AE Engineering, Inc.
 Senior Project Engineer

Date



S/WBE - M/WBE

400 EXECUTIVE CENTER DR. STE 210
WEST PALM BEACH, FL 33401
(561) 588-6681
Fax (561) 284-6541

CO/7 - Additional Drainage on Corona Street

March 26, 2021

To: City of Lake Worth Beach
7 North Dixie Highway
Lake Worth Beach, FL 33460

Project: Boutwell Rd. LW POC Pha
Project #: SG1804
FIN # :442094-1-58-01

ITEM #	BID ITEM: FURNISH AND INSTALL	QUANTITY	UNIT	UNIT PRICE	TOTAL
DM-1	Clearing & Grubbing Inc Asphalt & Base	0.08	AC	\$19,626.00	\$ 1,570.08
R-1	Regular Excavation	47	CY	\$ 11.00	\$ 517.00
D-8	Connect to Existing Structure	1	EA	\$ 2,090.00	\$ 2,090.00
R-5	12" Rock Base Course (2 Lifts)	45.8	SY	\$ 22.40	\$ 1,025.92
R-6	12" Stabilized Subgrade	45.8	SY	\$ 11.05	\$ 506.09
R-2	Superpave Asphaltic Concrete 1-1/2" SP 12.5	33.5	TN	\$ 138.00	\$ 4,623.00
R-3	Superpave Asphaltic Concrete 1" SP 9.5	22.3	TN	\$ 125.00	\$ 2,787.50
425-1-551	Inlet-Drainage; Ditch Bottom Type E	1	EA	\$ 5,376.69	\$ 5,376.69
D-9	RCP, Round, 18" S/CD	158	LF	\$ 210.00	\$33,180.00
L-9	Sod, Bahia	25	SY	\$ 5.45	\$ 136.25
D-5	Type P-7 Manhole	1	EA	\$ 8,140.00	\$ 8,140.00
TOTAL					\$59,952.53

Nancy G. Rosso
Managing Member

JOHNSON-DAVIS, INC.
 604 HILLBRATH DRIVE
 LANTANA, FL. 33462

DATE: 6 April, 2021

Lake Worth Park Of Commerce Project

Additional Drainage On Corona Street To 7th. Ave.

ITEM	Quantity	Price	AMOUNT
18" RCP	190.00	128	24,320.00
Type E Drain Structure	1.00	6500	6,500.00
New Structure w/ MH Top	1.00	6300	6,300.00
TOTAL Costs For This Work			\$ 37,120.00
All exclusions on original contract to apply to this proposal.			

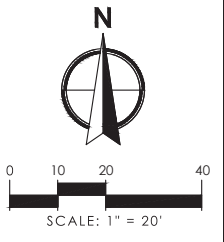
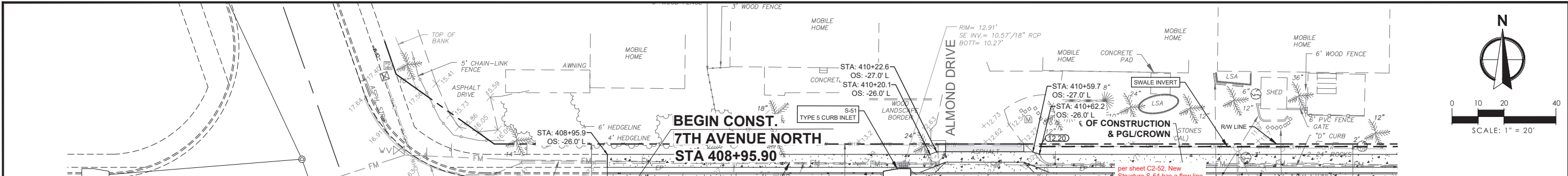

line of sight from proposed drainage location to new S-54 Drainage location below stop sign

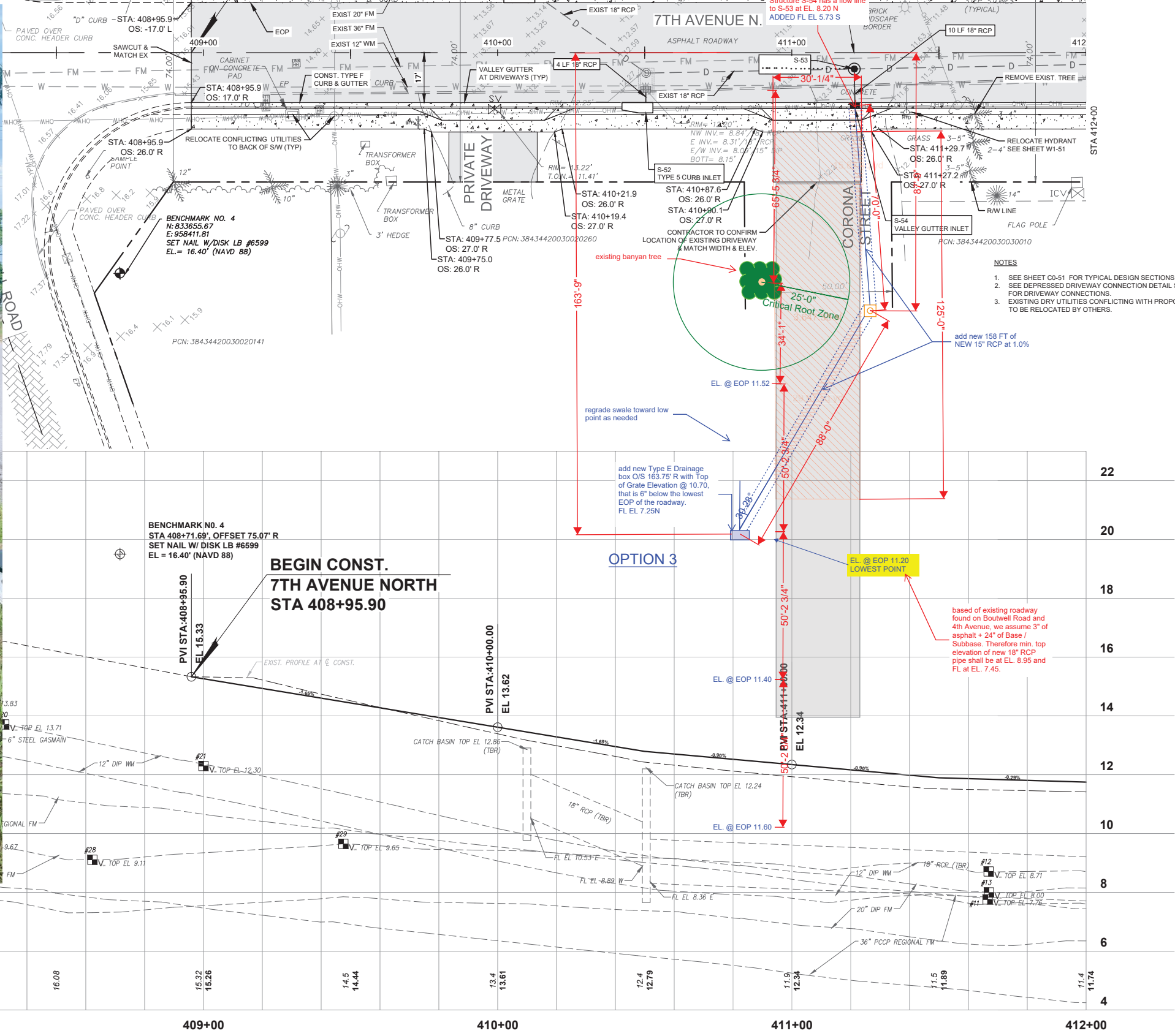

DWGI
2035 Vista Parkway, West Palm Beach, FL 33411
Phone No. 866.909.2220 www.dwginc.com
Cert No. 6091 - LB No. 7055

NO.	DATE	DESCRIPTION

CAD 25/450-400.DWG
JOB NO. 2974.05
DRAWN BY CAC
CHECK BY TEM
DATE 10/7/2019

ENGINEER OF RECORD
THOMAS MUELLER, P.E.
PE# 58119

PRODUCTION PLANS

CITY OF LAKE WORTH PARK OF COMMERCE - PHASE 2

PLAN & PROFILE VIEW - 7TH AVENUE NORTH

SHEET:
C1-51

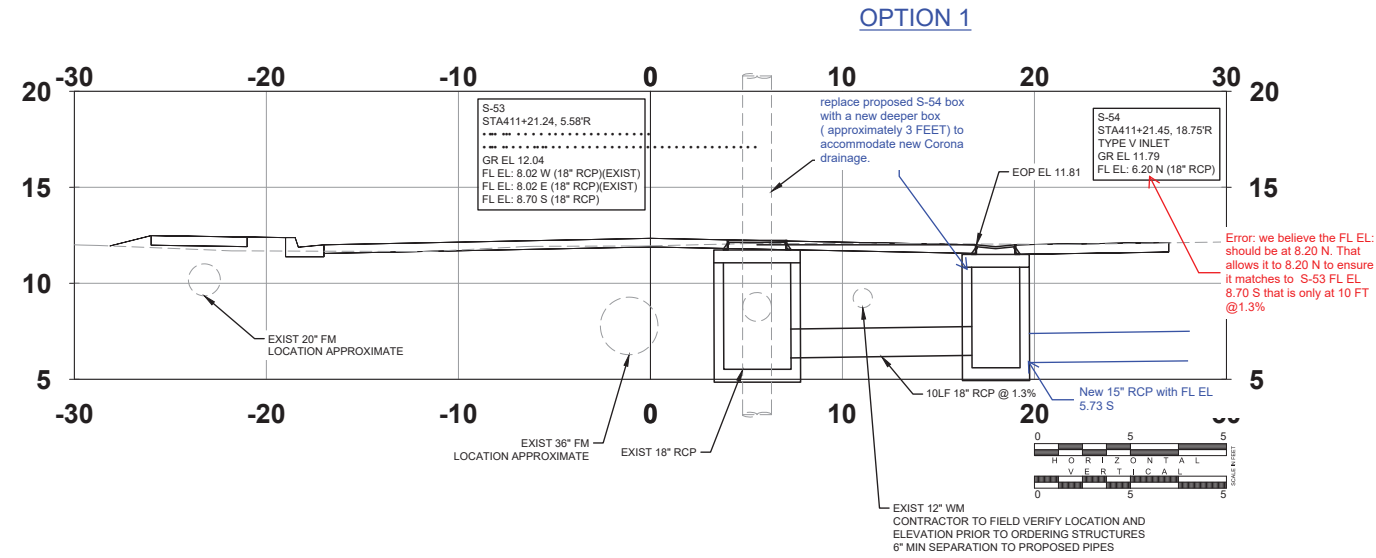
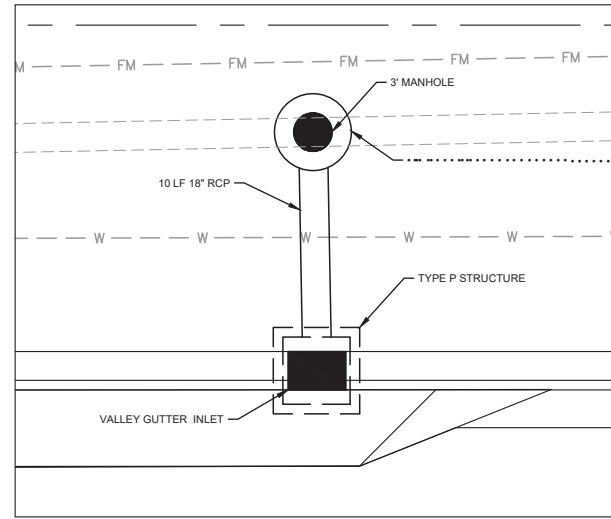

- NOTES**
- SEE SHEET C0-51 FOR DESIGN SECTIONS.
 - EXISTING UTILITIES CONFLICTING WITH PROPOSED WORK TO BE RELOCATED.
 - LOCATIONS OF EXISTING WATER MAINS AND FORCE MAINS SHOWN ARE APPROXIMATE AND TO BE FIELD VERIFIED PRIOR TO ORDERING MATERIALS.

DETAIL
STRUCTURES S-53 & S-54

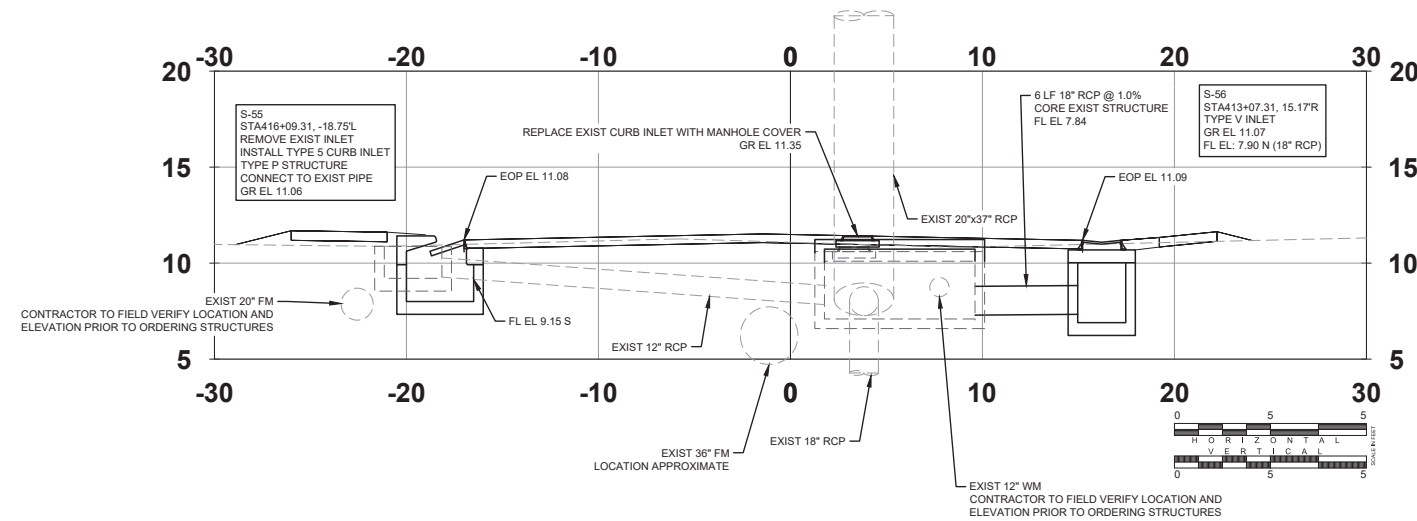
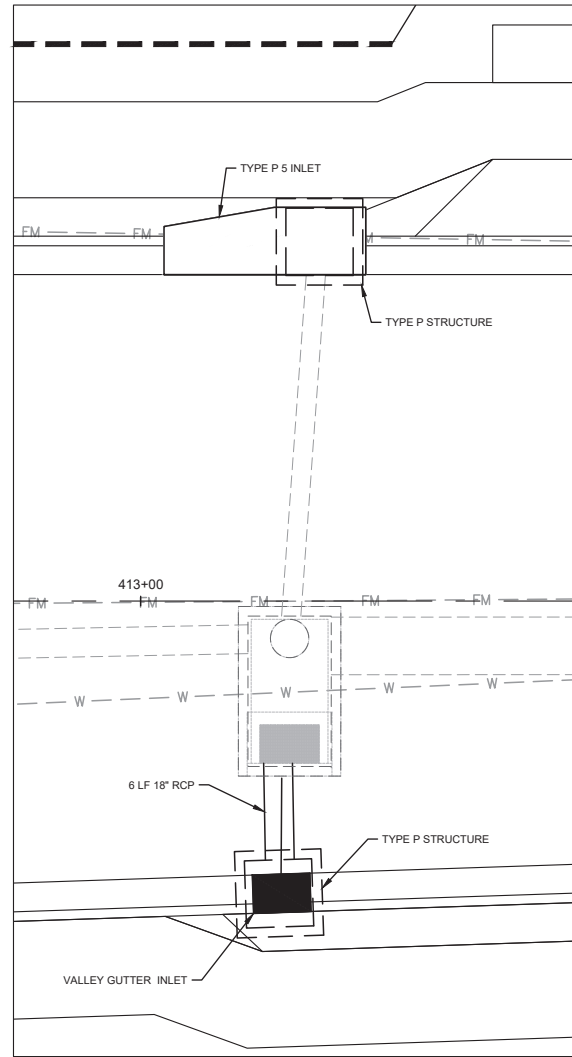

DETAIL
STRUCTURES S-55 & S-56

NO.	DATE	DESCRIPTION	BY
CAD 2074050/4000/DWG			
JOB NO.	2974-05		
DRAWN BY	CAC		
CHECK BY	TEM		
DATE	10/7/2019		

ENGINEER OF RECORD
THOMAS MUELLER, P.E.
PE# 58119