



GROWTH MANAGEMENT
 35 North Marion Ave.
 Lake City, FL 32055
 Telephone: (386)719-5750
 E-Mail:
 growthmanagement@lcfla.com

FOR PLANNING USE ONLY

Application # SPR 23-14
 Application Fee: \$200.00
 Receipt No. 2024-00001142
 Filing Date 10/02/23
 Completeness Date _____

Site Plan Application

A. PROJECT INFORMATION

1. Project Name: Tractor Supply Company
2. Address of Subject Property: TBD E. Duval St., Lake City, FL
3. Parcel ID Number(s): 33-3S-17-13061-000; 33-3S-17-13070-000; 33-3S-17-13079-000; 33-3S-17-13092-000
4. Future Land Use Map Designation: Commercial
5. Zoning Designation: Commercial Intensive (CI)
6. Acreage: ±3.57 AC
7. Existing Use of Property: Vacant
8. Proposed use of Property: Single Commercial Retail
9. Type of Development (Check All That Apply):
 - Increase of floor area to an existing structure: Total increase of square footage _____
 - New construction: Total square footage 21,930
 - Relocation of an existing structure: Total square footage _____

B. APPLICANT INFORMATION

1. Applicant Status Owner (title holder) Agent
2. Name of Applicant(s): H. Ray Hix, Jr. Title: Member
 Company name (if applicable): HSC Lake City, LLC
 Mailing Address: 805 Trione Ave
 City: Daphne State: AL Zip: 36526
 Telephone: (251) 243-0708 Fax: () Email: Johna@hixsnedeker.com

PLEASE NOTE: Florida has a very broad public records law. Most written communications to or from government officials regarding government business is subject to public records requests. Your e-mail address and communications may be subject to public disclosure.

3. If the applicant is agent for the property owner*.
 Property Owner Name (title holder): BORIS PATRICIA FAYE REVOCABLE LIVING TRUST
 Mailing Address: PO BOX 2095
 City: LAKE CITY State: FL Zip: 32056
 Telephone: () Fax: () Email: _____

PLEASE NOTE: Florida has a very broad public records law. Most written communications to or from government officials regarding government business is subject to public records requests. Your e-mail address and communications may be subject to public disclosure.

***Must provide an executed Property Owner Affidavit Form authorizing the agent to act on behalf of the property owner.**

C. ADDITIONAL INFORMATION

1. Is there any additional contract for the sale of, or options to purchase, the subject property?
If yes, list the names of all parties involved: No
If yes, is the contract/option contingent or absolute: Contingent Absolute
2. Has a previous application been made on all or part of the subject property? Yes No
Future Land Use Map Amendment: Yes _____ No _____
Future Land Use Map Amendment Application No. _____
Site Specific Amendment to the Official Zoning Atlas (Rezoning): Yes _____ No _____
Site Specific Amendment to the Official Zoning Atlas (Rezoning) Application No. Z23-04
Variance: Yes _____ No _____
Variance Application No. _____
Special Exception: Yes _____ No _____
Special Exception Application No. _____

D. ATTACHMENT/SUBMITTAL REQUIREMENTS

1. Vicinity Map – Indicating general location of the site, abutting streets, existing utilities, complete legal description of the property in question, and adjacent land use.
2. Site Plan – Including, but not limited to the following:
 - a. Name, location, owner, and designer of the proposed development.
 - b. Present zoning for subject site.
 - c. Location of the site in relation to surrounding properties, including the means of ingress and egress to such properties and any screening or buffers on such properties.
 - d. Date, north arrow, and graphic scale not less than one inch equal to 50 feet.
 - e. Area and dimensions of site (Survey).
 - f. Location of all property lines, existing right-of-way approaches, sidewalks, curbs, and gutters.
 - g. Access to utilities and points of utility hook-up.
 - h. Location and dimensions of all existing and proposed parking areas and loading areas.
 - i. Location, size, and design of proposed landscaped areas (including existing trees and required landscaped buffer areas).
 - j. Location and size of any lakes, ponds, canals, or other waters and waterways.
 - k. Structures and major features fully dimensioned including setbacks, distances between structures, floor area, width of driveways, parking spaces, property or lot lines, and percent of property covered by structures.
 - l. Location of trash receptacles.
 - m. For multiple-family, hotel, motel, and mobile home park site plans:
 - i. Tabulation of gross acreage.
 - ii. Tabulation of density.
 - iii. Number of dwelling units proposed.
 - iv. Location and percent of total open space and recreation areas.
 - v. Percent of lot covered by buildings.

- vi. Floor area of dwelling units.
 - vii. Number of proposed parking spaces.
 - viii. Street layout.
 - ix. Layout of mobile home stands (for mobile home parks only).
3. Stormwater Management Plan—including the following:
 - a. Existing contours at one foot intervals based on U.S. Coast and Geodetic Datum.
 - b. Proposed finished elevation of each building site and first floor level.
 - c. Existing and proposed stormwater management facilities with size and grades.
 - d. Proposed orderly disposal of surface water runoff.
 - e. Centerline elevations along adjacent streets.
 - f. Water management district surface water management permit.
 4. Fire Department Access and Water Supply Plan: The Fire Department Access and Water Supply Plan must demonstrate compliance with Chapter 18 of the Florida Fire Prevention Code, be located on a separate signed and sealed plan sheet, and must be prepared by a professional fire engineer licensed in the State of Florida. The Fire Department Access and Water Supply Plan must contain fire flow calculations in accordance with the Guide for Determination of Required Fire Flow, latest edition, as published by the Insurance Service Office (“ISO”) and/or Chapter 18, Section 18.4 of the Florida Fire Prevention Code, whichever is greater.
 5. Concurrency Impact Analysis: Concurrency Impact Analysis of impacts to public facilities. For commercial and industrial developments, an analysis of the impacts to Transportation, Potable Water, Sanitary Sewer, and Solid Waste impacts are required.
 6. Comprehensive Plan Consistency Analysis: An analysis of the application’s consistency with the Comprehensive Plan (analysis must identify specific Goals, Objectives, and Policies of the Comprehensive Plan and detail how the application complies with said Goals, Objectives, and Policies).
 7. Legal Description with Tax Parcel Number (In Word Format).
 8. Proof of Ownership (i.e. deed).
 9. Agent Authorization Form (signed and notarized).
 10. Proof of Payment of Taxes (can be obtained online via the Columbia County Tax Collector’s Office).
 11. Fee. The application fee for a Site and Development Plan Application is \$200.00. No application shall be accepted or processed until the required application fee has been paid.

NOTICE TO APPLICANT

All eleven (11) attachments are required for a complete application. Once an application is submitted and paid for, a completeness review will be done to ensure all the requirements for a complete application have been met. If there are any deficiencies, the applicant will be notified in writing. If an application is deemed to be incomplete, it may cause a delay in the scheduling of the application before the Planning & Zoning Board.

A total of ten (10) copies of proposed site plan application and all support materials must be submitted along with a PDF copy on a CD. See City of Lake City submittal guidelines for additional submittal requirements.

THE APPLICANT ACKNOWLEDGES THAT THE APPLICANT OR AGENT MUST BE PRESENT AT THE PUBLIC HEARING BEFORE THE PLANNING AND ZONING BOARD, AS ADOPTED IN THE BOARD RULES AND PROCEDURES. OTHERWISE THE REQUEST MAY BE CONTINUED TO A FUTURE HEARING DATE.

I hereby certify that all of the above statements and statements contained in any documents or plans submitted herewith are true and accurate to the best of my knowledge and belief.

H. Ray Hix, Jr.

Applicant/Agent Name (Type or Print)

[Handwritten Signature]

Applicant/Agent Signature

9/21/23

Date

Applicant/Agent Name (Type or Print)

Applicant/Agent Signature

Date

STATE OF FLORIDA *Alabama*
COUNTY OF *Baldwin*

The foregoing instrument was acknowledged before me this *21st* day of *September*, 20*23*, by (name of person acknowledging).

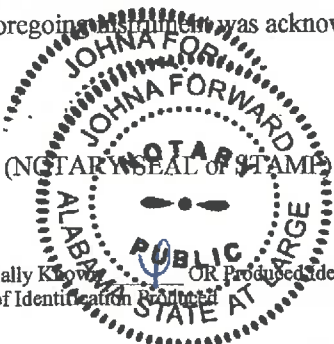

John Forward

Signature of Notary

Printed Name of Notary

exp. 2/24/26

Personally Known _____
Type of Identification Produced Identification _____



Columbia County Property Appraiser Jeff Hampton | Lake City, Florida | 386-758-1083

PARCEL: 33-3S-17-13061-000 (41581) | VACANT COMMERCIAL (1000) | 2.267 AC
 E DIV BEG INTERS S DUVAL ST & W RW WALDRON ST, RUN SE 18.86 FT, SW ALONG RW 512 FT TO N RW ST JOHN ST, W ALONG RW 187.32 FT, N 506.17 FT TO S RW

Owner: BORIS PATRICIA FAYE REVOCABLE LIVING TRUST
 LAKE CITY, FL 32056

Site: \$100 V(U) \$16/2007

2024 Working Values		2024 Working Values	
Mkt Lnd	Appraised	Mkt Lnd	Appraised
Ag Lnd	\$0	Ag Lnd	\$151,545
Bldg	\$0	Bldg	\$0
XFOB	\$0	XFOB	\$0
Just	\$151,545	Just	\$151,545
Total		Total	
Taxable		Taxable	
		county:	\$151,545
		city:	\$151,545
		other:	\$0
		school:	\$151,545

NOTES:

This information, was derived from data which was compiled by the Columbia County Property Appraiser Office solely for the governmental purpose of property assessment. This information should not be relied upon by anyone as a determination of the ownership of property or market value. No warranties, expressed or implied, are provided for the accuracy of the data herein, it's use, or it's interpretation. Although it is periodically updated, this information may not reflect the data currently on file in the Property Appraiser's office.

Columbia County, FL
GrizzlyLogic.com

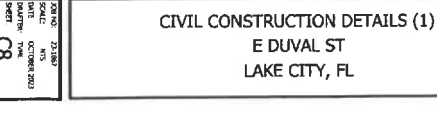
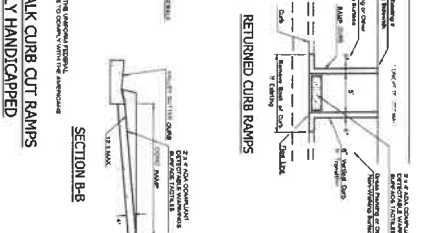
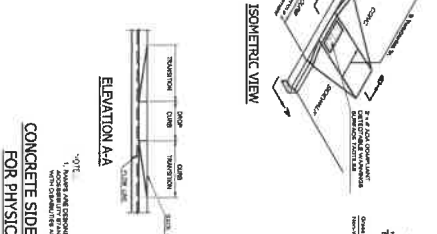
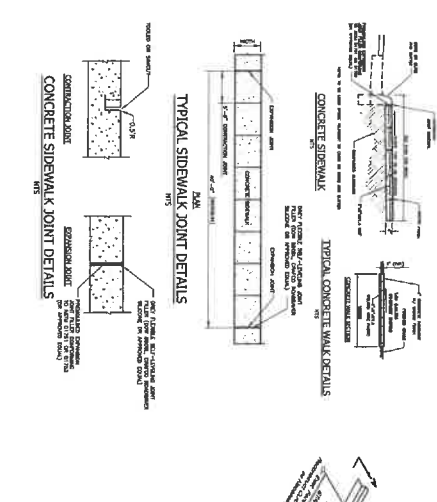
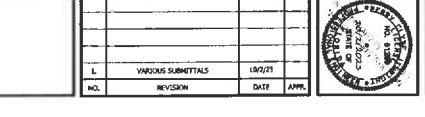
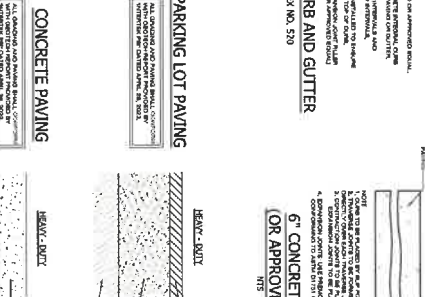
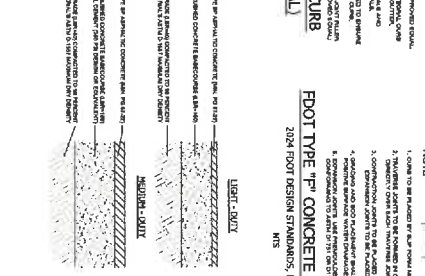
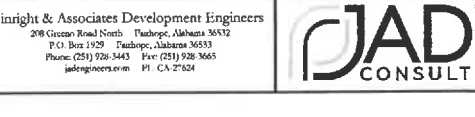
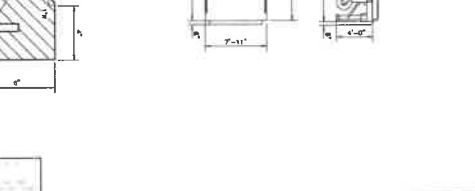
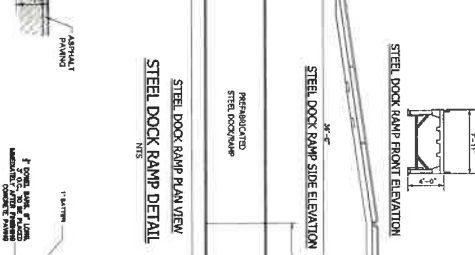
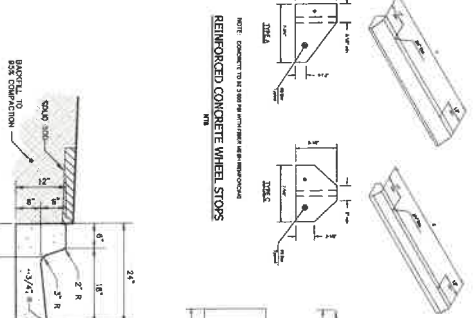
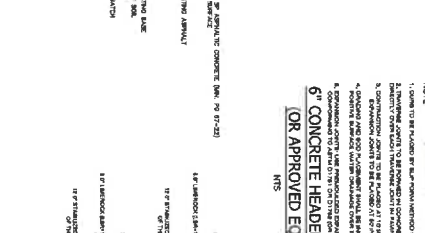
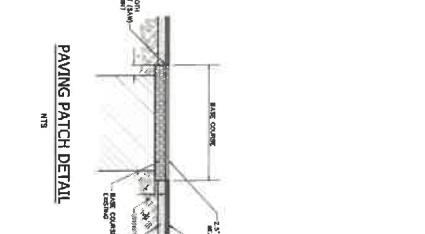
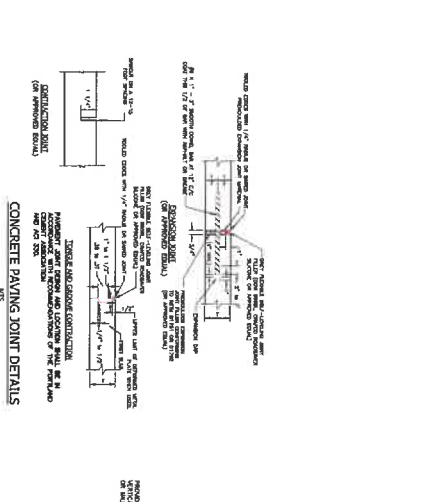
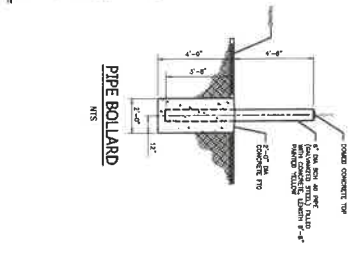
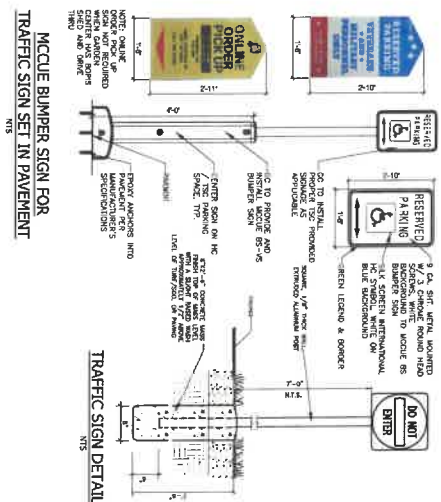

GENERAL NOTE:
 1. ALL DIMENSIONS ARE IN FEET AND INCHES UNLESS OTHERWISE NOTED.
 2. ALL DIMENSIONS ARE TO FACE UNLESS OTHERWISE NOTED.
 3. ALL DIMENSIONS ARE TO CENTERLINE UNLESS OTHERWISE NOTED.
 4. ALL DIMENSIONS ARE TO CENTERLINE UNLESS OTHERWISE NOTED.
 5. ALL DIMENSIONS ARE TO CENTERLINE UNLESS OTHERWISE NOTED.

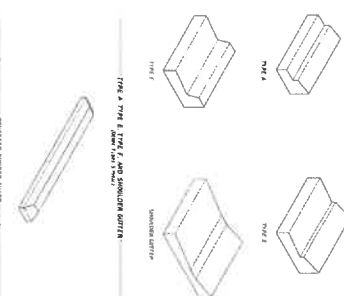

FIG. 1 TYPE 1, 2, 3 CURB AND GUTTER

CONCRETE CURB AND GUTTER

DATE: 10/20/2023
 PROJECT: STANFORD PLANS
 SHEET: 127.3
 DRAWN BY: [Name]
 CHECKED BY: [Name]

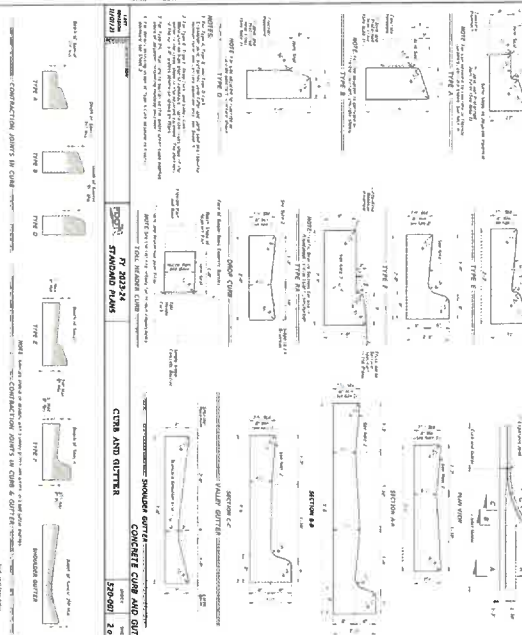

FIG. 2 TYPE 4, 5, 6 CURB AND GUTTER

CONCRETE CURB AND GUTTER

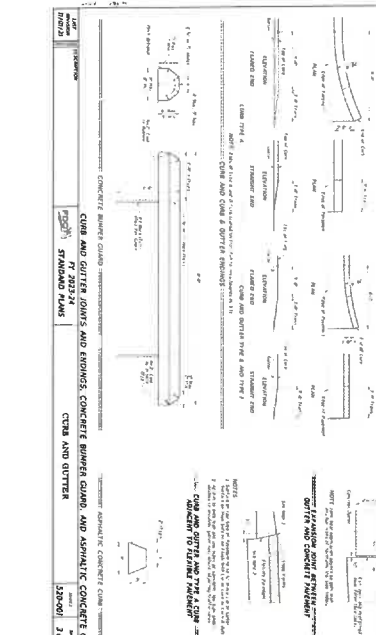
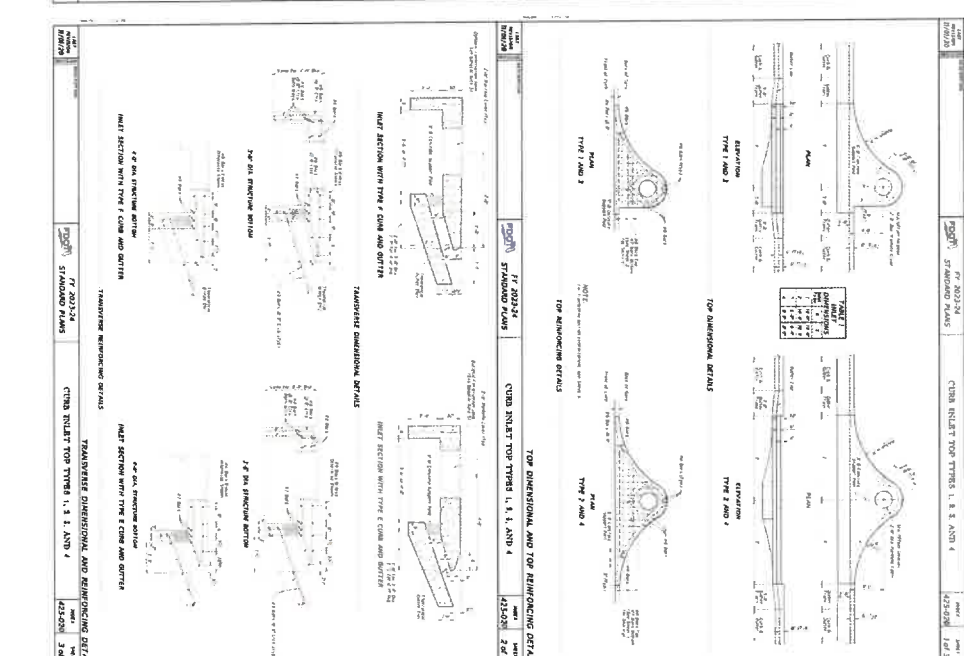

FIG. 3 TYPE 7, 8, 9 CURB AND GUTTER

CONCRETE CURB AND GUTTER



DATE: 10/20/2023
 PROJECT: STANFORD PLANS
 SHEET: 127.3
 DRAWN BY: [Name]
 CHECKED BY: [Name]

GENERAL NOTE:
 1. ALL DIMENSIONS ARE IN FEET AND INCHES UNLESS OTHERWISE NOTED.
 2. ALL DIMENSIONS ARE TO FACE UNLESS OTHERWISE NOTED.
 3. ALL DIMENSIONS ARE TO CENTERLINE UNLESS OTHERWISE NOTED.
 4. ALL DIMENSIONS ARE TO CENTERLINE UNLESS OTHERWISE NOTED.
 5. ALL DIMENSIONS ARE TO CENTERLINE UNLESS OTHERWISE NOTED.

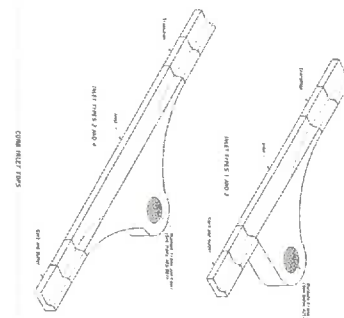

FIG. 4 TYPE 10, 11 CURB AND GUTTER

CONCRETE CURB AND GUTTER

DATE: 10/20/2023
 PROJECT: STANFORD PLANS
 SHEET: 127.3
 DRAWN BY: [Name]
 CHECKED BY: [Name]

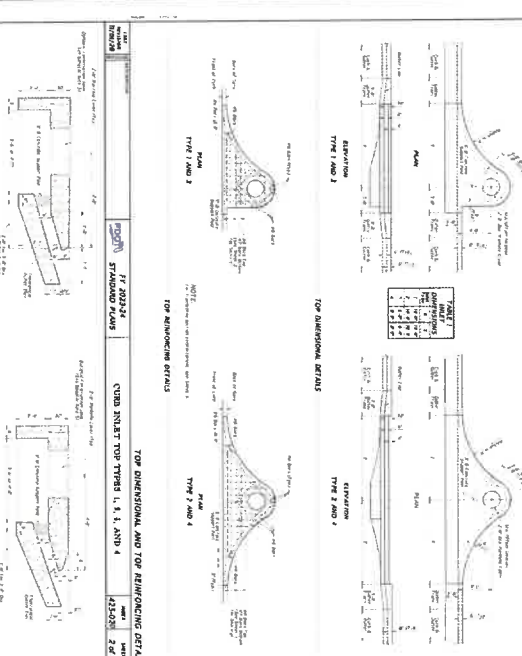

FIG. 5 TYPE 12, 13, 14 CURB AND GUTTER

CONCRETE CURB AND GUTTER

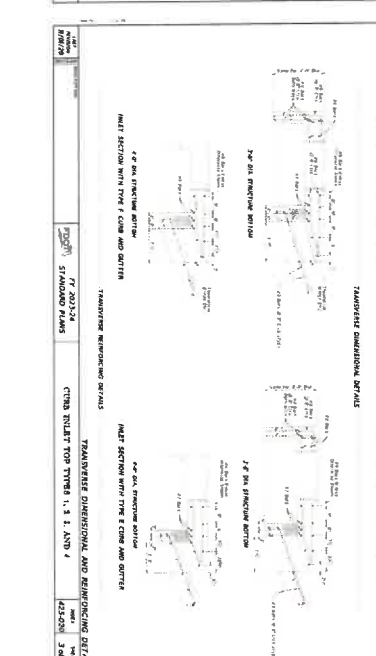

FIG. 6 TYPE 15, 16, 17 CURB AND GUTTER

CONCRETE CURB AND GUTTER

TABLE OF CONTENTS

NO.	DESCRIPTION	SHEET NO.
1	GENERAL NOTES	127.1
2	TYPE 1, 2, 3 CURB AND GUTTER	127.2
3	TYPE 4, 5, 6 CURB AND GUTTER	127.3
4	TYPE 7, 8, 9 CURB AND GUTTER	127.4
5	TYPE 10, 11 CURB AND GUTTER	127.5
6	TYPE 12, 13, 14 CURB AND GUTTER	127.6
7	TYPE 15, 16, 17 CURB AND GUTTER	127.7
8	TOP DIMENSIONAL AND TOP REINFORCING DETAILS	127.8
9	TRANSVERSE DIMENSIONAL DETAILS	127.9
10	TRANSVERSE DIMENSIONAL AND REINFORCING DETAILS	127.10
11	WRAPPED PIPE JOINT DETAIL	127.11

TOP AND BOTTOM REINFORCING - TYPE 1

NO.	DESCRIPTION	QUANTITY
1	REINFORCING BAR	100
2	REINFORCING BAR	100
3	REINFORCING BAR	100
4	REINFORCING BAR	100
5	REINFORCING BAR	100
6	REINFORCING BAR	100
7	REINFORCING BAR	100
8	REINFORCING BAR	100
9	REINFORCING BAR	100
10	REINFORCING BAR	100

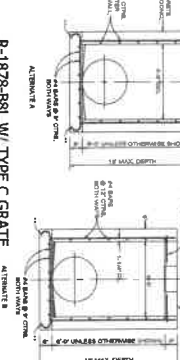
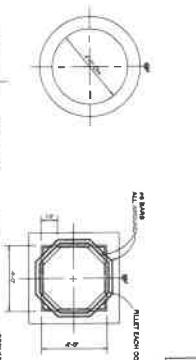

R-1878-881 W/ TYPE C GRATE WITH TYPE "P" BOTTOM DETAIL

1. ALL DIMENSIONS ARE IN FEET AND INCHES UNLESS OTHERWISE NOTED.
 2. ALL DIMENSIONS ARE TO FACE UNLESS OTHERWISE NOTED.
 3. ALL DIMENSIONS ARE TO CENTERLINE UNLESS OTHERWISE NOTED.
 4. ALL DIMENSIONS ARE TO CENTERLINE UNLESS OTHERWISE NOTED.
 5. ALL DIMENSIONS ARE TO CENTERLINE UNLESS OTHERWISE NOTED.

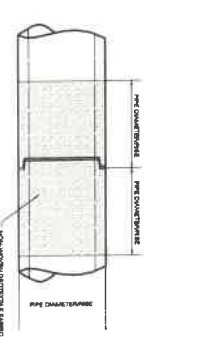

WRAPPED PIPE JOINT DETAIL

CONCRETE CURB AND GUTTER

GENERAL NOTES

1. Refer to the project manual for Section 05100.
2. All work shall be in accordance with the project manual and the applicable building codes.
3. All work shall be in accordance with the project manual and the applicable building codes.
4. All work shall be in accordance with the project manual and the applicable building codes.
5. All work shall be in accordance with the project manual and the applicable building codes.
6. All work shall be in accordance with the project manual and the applicable building codes.
7. All work shall be in accordance with the project manual and the applicable building codes.
8. All work shall be in accordance with the project manual and the applicable building codes.
9. All work shall be in accordance with the project manual and the applicable building codes.
10. All work shall be in accordance with the project manual and the applicable building codes.

REINFORCEMENT NOTES

1. Refer to the project manual for Section 05100.
2. All work shall be in accordance with the project manual and the applicable building codes.
3. All work shall be in accordance with the project manual and the applicable building codes.
4. All work shall be in accordance with the project manual and the applicable building codes.
5. All work shall be in accordance with the project manual and the applicable building codes.
6. All work shall be in accordance with the project manual and the applicable building codes.
7. All work shall be in accordance with the project manual and the applicable building codes.
8. All work shall be in accordance with the project manual and the applicable building codes.
9. All work shall be in accordance with the project manual and the applicable building codes.
10. All work shall be in accordance with the project manual and the applicable building codes.

TABLE OF CONTENTS

SECTION	DESCRIPTION
05100	CONCRETE
05110	FORMWORK
05120	REINFORCEMENT
05130	CAST-IN-PLACE CONCRETE
05140	PRECAST/PRECASTER CONCRETE
05150	CONCRETE CURING
05160	CONCRETE PROTECTION
05170	CONCRETE REPAIR
05180	CONCRETE TESTING
05190	CONCRETE CURB
05200	CONCRETE CURB
05210	CONCRETE CURB
05220	CONCRETE CURB
05230	CONCRETE CURB
05240	CONCRETE CURB
05250	CONCRETE CURB
05260	CONCRETE CURB
05270	CONCRETE CURB
05280	CONCRETE CURB
05290	CONCRETE CURB
05300	CONCRETE CURB

PROJECT: **RY 2023-24**
 STANDARD PLANS
 STRUCTURE BOTTOMS TYPE J AND P
 SHEET: **425-010**
 OF: **4**

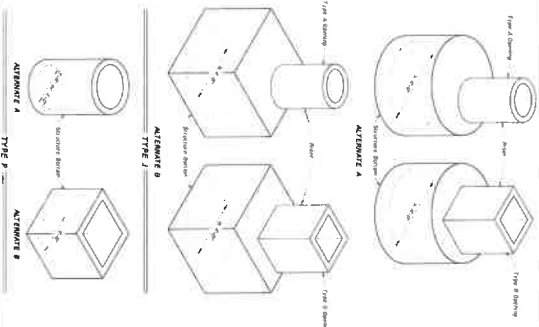

TABLE 1 - ALTERNATE A - STRUCTURES

SECTION	DESCRIPTION	REMARKS
1
2
3
4
5
6
7
8
9
10

TABLE 2 - ALTERNATE B - STRUCTURES

SECTION	DESCRIPTION	REMARKS
1
2
3
4
5
6
7
8
9
10

TABLE 3 - REINFORCING SCHEDULE

SECTION	DESCRIPTION	REMARKS
1
2
3
4
5
6
7
8
9
10

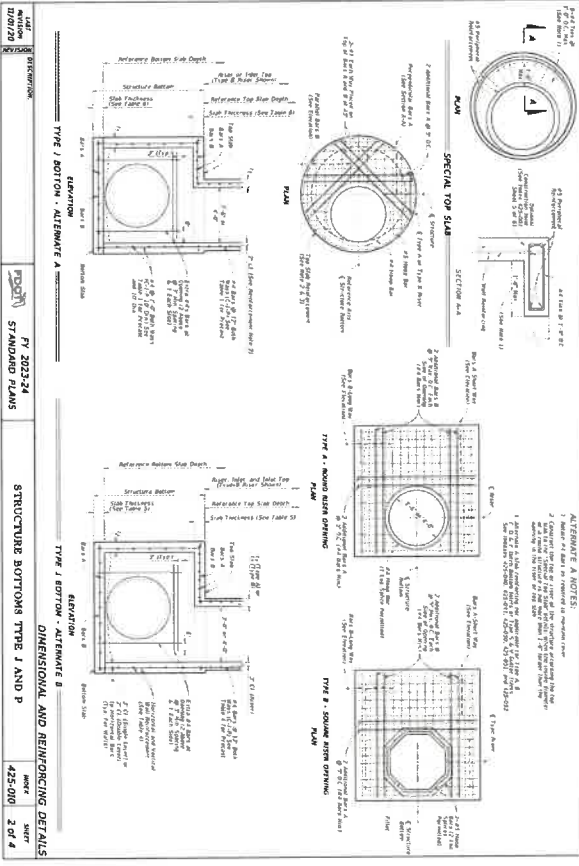

TABLE 4 - SLAB DESIGNS - SQUARE AND RECTANGULAR STRUCTURES

SECTION	DESCRIPTION	REMARKS
1
2
3
4
5
6
7
8
9
10

TABLE 5 - SLAB DESIGNS - SQUARE AND RECTANGULAR STRUCTURES

SECTION	DESCRIPTION	REMARKS
1
2
3
4
5
6
7
8
9
10

TABLE 6 - SLAB DESIGNS - ROUND STRUCTURES

SECTION	DESCRIPTION	REMARKS
1
2
3
4
5
6
7
8
9
10

Jinright & Associates Development Engineers
 208 Greeno Road North, Tallapoosa, Alabama 36555
 P.O. Box 1929, Tallapoosa, Alabama 36555
 Phone: (251) 926-5443 Fax: (251) 926-5665
 www.jinright.com

JADE CONSULTING

CIVIL CONSTRUCTION DETAILS (3)
 E DUVAL ST
 LAKE CITY, FL

DATE: 10/23/23
 REVISION: 1

PROJECT: **RY 2023-24**
 STANDARD PLANS
 STRUCTURE BOTTOMS TYPE J AND P
 SHEET: **425-010**
 OF: **4**

PIPE SIZE	SLOPE	A	B	(A/B)	(B/A)
12"	4:1	6'-0"	6'-0"	1.0	1.0
18"	4:1	6'-0"	9'-0"	1.5	0.67
24"	4:1	6'-0"	12'-0"	2.0	0.5

GENERAL NOTES:
 1. MATERIAL SHALL BE AS SHOWN AND THE SHOP AND ALL SPECIFICATIONS SHALL BE MET.
 2. QUANTITIES SHOWN INCLUDES TWO (2) CONCRETE HEADWALLS, UNLESS NOTED OTHERWISE.
 3. WHERE A 1:1 SLOPE IS REQUIRED, THE SLOPE SHALL BE ADJUSTED AS NECESSARY TO FIT.
 4. A 1:1 SLOPE SHALL BE MAINTAINED TO THE TOP OF THE WALL AND THE SLOPE SHALL BE MAINTAINED TO THE TOP OF THE WALL.
 5. DETAILS AND QUANTITIES SHOWN ON THIS DRAWING APPLY TO REINFORCED CONCRETE AND CONCRETE PIPE PIPES.
 6. SLOPE HEADS WITHOUT GATES SHALL BE CLASS 1. HEADWALLS WITH GATES SHALL BE CLASS 2.
 7. HEADWALLS SHALL BE CONSTRUCTED TO THE TOP OF THE HEADWALL AND SHALL BE REINFORCED FOR THE ENTIRE HEIGHT.
 8. HEADWALLS SHALL BE REINFORCED TO THE TOP OF THE HEADWALL AND SHALL BE REINFORCED TO THE TOP OF THE HEADWALL.
 9. A HEADWALL OF 12" PIPE SHALL BE 12" HIGH FROM THE TOP OF THE HEADWALL TO THE TOP OF THE HEADWALL.
 10. ADJACENT PIPES SHALL HAVE A CLEAR SPACE WHICH SHALL BE AT LEAST ONE (1) FOOT FROM THE PIPE.

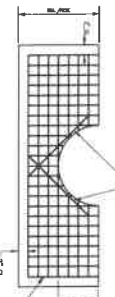
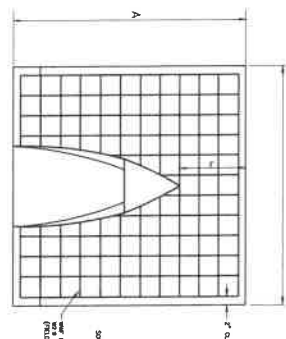

END VIEW - CONCRETE PIPE
SLOPE PAVED HEADWALL FOR REINFORCED CONCRETE PIPE

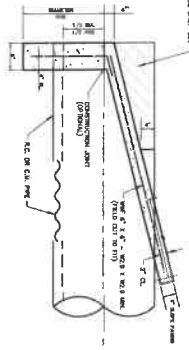

SIDE VIEW

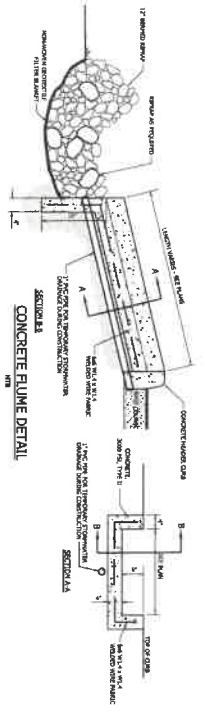

SECTION A-A
CONCRETE PIPE DETAIL

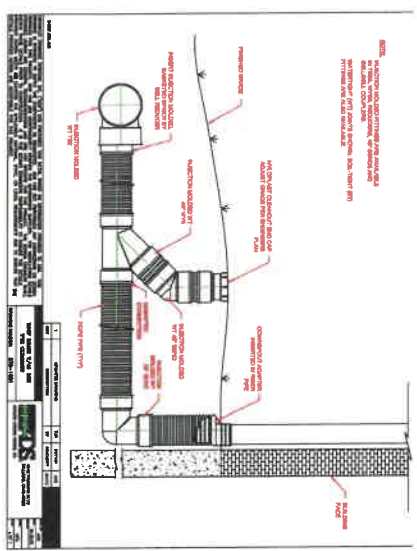

SECTION B-B

12-30" NYLON LAST DRAIN BASIN WITH DOME GRATE AND CONCRETE POUR BASIN

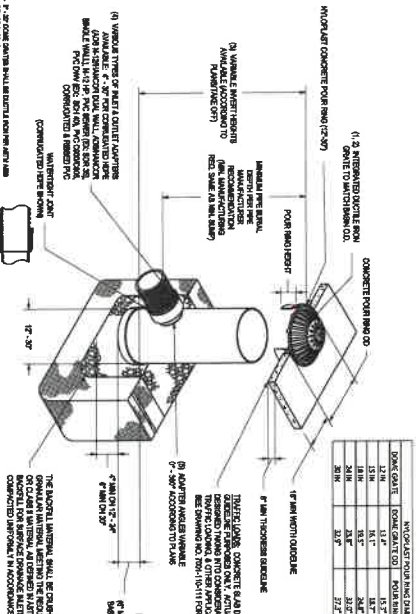

DRAIN SIZE	CONCRETE POUR BASIN DIMENSIONS	CONCRETE POUR BASIN DIMENSIONS
12" DIA	12" x 12" x 12"	12" x 12" x 12"
18" DIA	18" x 18" x 18"	18" x 18" x 18"
24" DIA	24" x 24" x 24"	24" x 24" x 24"
30" DIA	30" x 30" x 30"	30" x 30" x 30"
36" DIA	36" x 36" x 36"	36" x 36" x 36"
42" DIA	42" x 42" x 42"	42" x 42" x 42"

1. THE CONCRETE SHALL BE REINFORCED WITH #4 BARS AT 12" ON CENTER.
 2. THE CONCRETE SHALL BE REINFORCED WITH #4 BARS AT 12" ON CENTER.
 3. THE CONCRETE SHALL BE REINFORCED WITH #4 BARS AT 12" ON CENTER.
 4. THE CONCRETE SHALL BE REINFORCED WITH #4 BARS AT 12" ON CENTER.
 5. THE CONCRETE SHALL BE REINFORCED WITH #4 BARS AT 12" ON CENTER.
 6. THE CONCRETE SHALL BE REINFORCED WITH #4 BARS AT 12" ON CENTER.
 7. THE CONCRETE SHALL BE REINFORCED WITH #4 BARS AT 12" ON CENTER.
 8. THE CONCRETE SHALL BE REINFORCED WITH #4 BARS AT 12" ON CENTER.
 9. THE CONCRETE SHALL BE REINFORCED WITH #4 BARS AT 12" ON CENTER.
 10. THE CONCRETE SHALL BE REINFORCED WITH #4 BARS AT 12" ON CENTER.

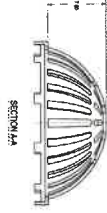
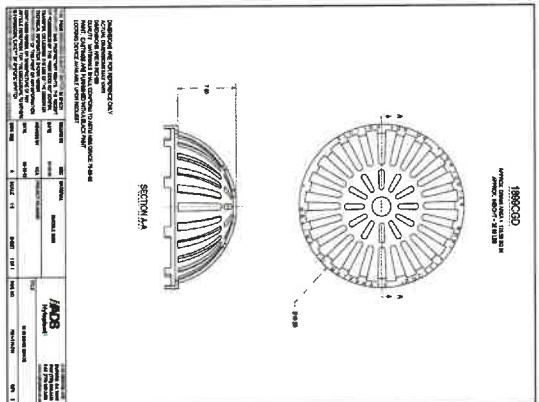

DRAIN SIZE	CONCRETE POUR BASIN DIMENSIONS	CONCRETE POUR BASIN DIMENSIONS
12" DIA	12" x 12" x 12"	12" x 12" x 12"
18" DIA	18" x 18" x 18"	18" x 18" x 18"
24" DIA	24" x 24" x 24"	24" x 24" x 24"
30" DIA	30" x 30" x 30"	30" x 30" x 30"
36" DIA	36" x 36" x 36"	36" x 36" x 36"
42" DIA	42" x 42" x 42"	42" x 42" x 42"

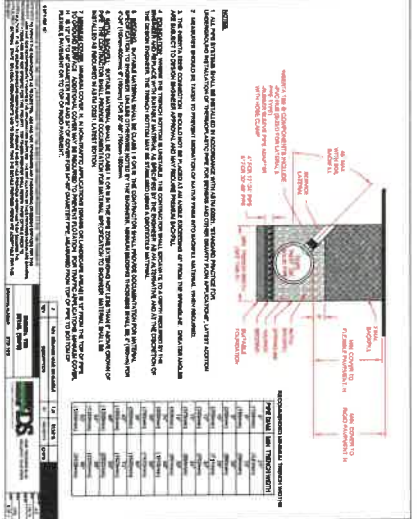

SECTION C-C

NO.	DESCRIPTION	DATE	BY	CHKD.
1	ISSUED FOR PERMIT	10/20/23	JAS	JAS
2	ISSUED FOR CONSTRUCTION	10/20/23	JAS	JAS
3	ISSUED FOR AS-BUILT	10/20/23	JAS	JAS



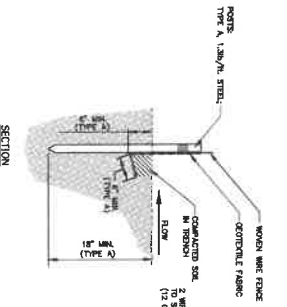
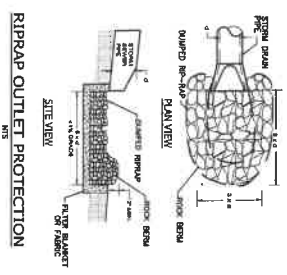
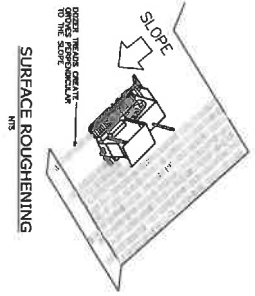

TYPICAL SILT FENCE INSTALLATION
N/S

GENERAL NOTES

- TYPE "X" SILT FENCE SHALL NOT BE USED IN AREAS OF CONCENTRATED FLOW.
- SILT FENCES ARE TEMPORARY EROSION CONTROL. THEY SHALL NOT BE USED TO PERMANENTLY STABILIZE EROSION CONTROL. ALL SITES AND ADJACENT TO EROSION CONTROL SHALL BE REPAIRED OR REPLACED DURING FENCE AND SUPPORTS AS NEEDED TO RESTORE THE EROSION CONTROL TO ORIGINAL CONDITION. THE EROSION CONTROL SHALL BE REMOVED OR REPAIRED WITHIN 30 DAYS OF THE END OF CONSTRUCTION.
- WHEREVER POSSIBLE, SILT FENCES SHALL BE CONSTRUCTED ACROSS A FLOW PATH IN THE SLOPE OF A HILLSIDE. THIS AID IN PROMOTING A FLOW PATH TO THE BOTTOM OF THE SLOPE.
- AFTER THE CONSTRUCTION AREA IS STABILIZED AND EROSION ACTIVITY CESSATED, SILT FENCES SHALL BE REMOVED.
- WALK PATHWAYS USED TO SECURE OBJECTS TO WOOD PILES SHALL BE 12 IN. WIDE.
- WALK PATHWAYS USED TO SECURE OBJECTS TO WOOD PILES SHALL BE 17 IN. WIDE.
- POSTS SHALL BE 1 1/2 IN. DIA. GALV. STEEL AND 1/2 IN. DIA. GALV. STEEL SHALL BE IN 40 IN. DIA. GALV. STEEL. 1" DIA. GALV. STEEL SHALL BE IN 1 1/2 IN. DIA. GALV. STEEL.
- WOOD PILES TO BE 12 1/2 IN. DIA. (MINIMUM).

SPECIFICATIONS

CONCRETE FLOOR, CURB, AND TYPICAL EROSION CONTROL, AND STORMWATER MANAGEMENT ON CONSTRUCTION SITES AND NEIGHBORHOODS

BLOCK & GRAVEL CURB INLET SEDIMENT FILTER

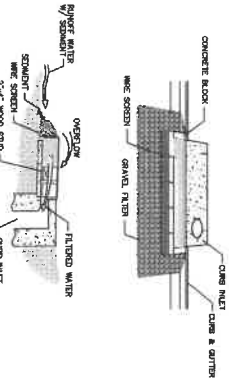

INSTALLATION OF BLOCK AND GRAVEL CURB INLET SEDIMENT FILTER SHALL BE AS SHOWN IN THIS DETAIL. THE FILTER SHALL BE INSTALLED IN FRONT OF THE STRUCTURE. THE STRUCTURE SHALL BE INSPECTED AFTER EACH RAIN AND REPAIRS AS NECESSARY.

- THE STRUCTURE SHALL BE INSPECTED AFTER EACH RAIN AND REPAIRS AS NECESSARY.
- REPAIRS SHALL BE MADE TO THE STRUCTURE TO THE ORIGINAL CONDITION.
- REPAIRS SHALL BE MADE TO THE ORIGINAL CONDITION.
- REPAIRS SHALL BE MADE TO THE ORIGINAL CONDITION.

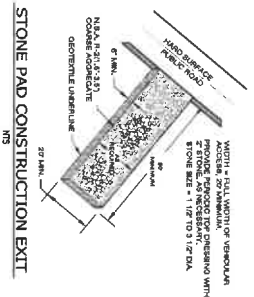

TYPICAL INLET EROSION CONTROL

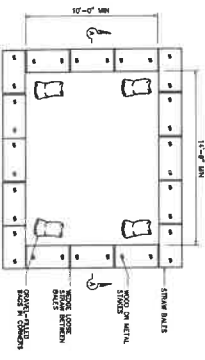
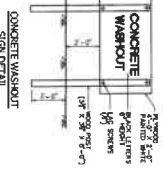
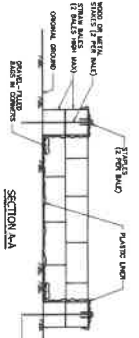
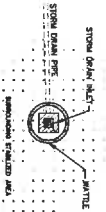

TEMPORARY CONCRETE WASHOUT FACILITY
(SEE DETAIL)

EROSION CONTROL DETAILS
E DUVAL ST
LAKE CITY, FL

NO.	REVISION	DATE	APP.
1	VARIOUS SUBMITTALS	10/2/20	



Jinright & Associates Development Engineers
206 Green Road North, Dothan, Alabama 36532
P.O. Box 1929, Enterprise, Alabama 36533
Phone: (251) 928-3443 Fax: (251) 928-3665
jadesj@earthlink.net P1: CA 27824



DATE: 10/2/20
SCALE: 1" = 4'-0"
DRAWN BY: J. M. JADE
CHECKED BY: J. M. JADE
PROJECT: C15
EROSION CONTROL DETAILS

E DUVAL ST
 SPEED LIMIT
45
 POSTED SPEED LIMIT

TRAFFIC CONTROL PLAN
 ALL TEMPORARY TRAFFIC CONTROL SHALL COMPLY WITH PART 8 OF THE
 MANUAL ON UNIFORM TRAFFIC CONTROL DEVICES (MUTCD) CURRENT EDITION AND 1997 REQUIREMENTS.
 POSTED SPEED LIMIT OF E DUVAL ST (06 MPH 80) IS 40 MPH

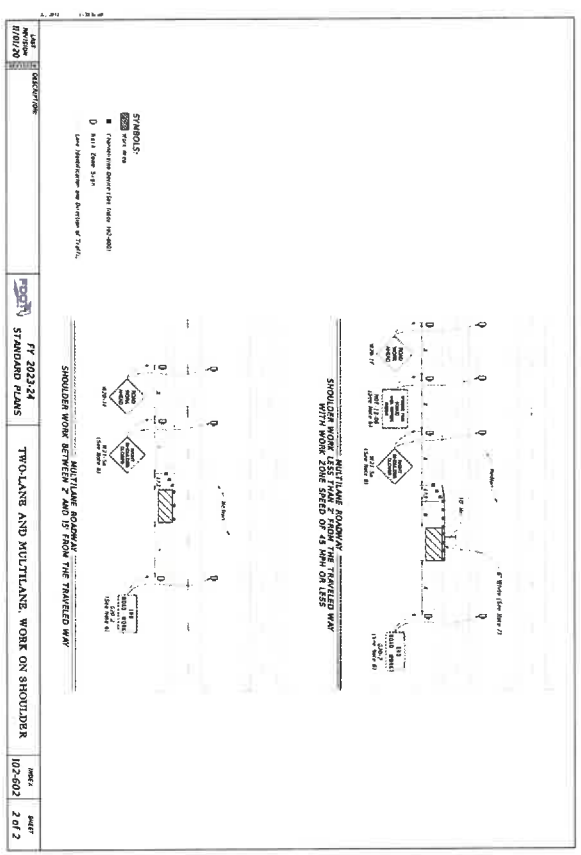
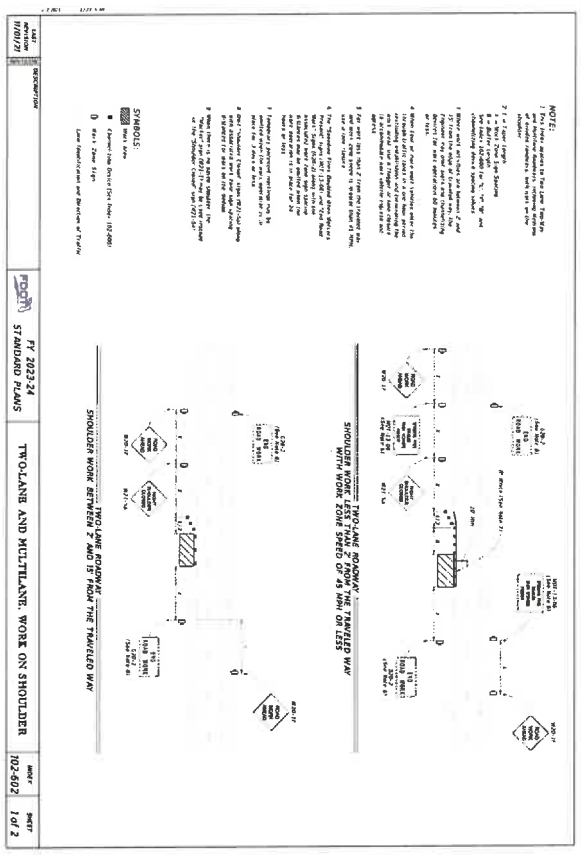

NO.	REVISION	DATE	APP.
1	VARIOUS SUBMITTALS	WAZ/CL	



Jinright & Associates Development Engineers
 298 Green Road North, Prichard, Alabama 36132
 P.O. Box 1929, Prichard, Alabama 36133
 Phone: (251) 928-3443 Fax: (251) 928-3665
 jinrightengineers.com P. O. Box 27024



TRAFFIC CONTROL PLAN
 E DUVAL ST
 LAKE CITY, FL

DATE: 10/26/23
 SCALE: 1" = 30'
 SHEETS: 2 OF 2
 PROJECT: C16
 DRAWING: C16

TRACTOR SUPPLY COMPANY

Comprehensive Plan

Justification Report

Prepared for:
City of Lake City

Prepared on behalf of:
Hix Snedeker Companies
And property owners:
Patricia Faye Boris Revocable Living Trust

Prepared by:



Post Office Box 1929 Fairhope, AL 36533

PHONE: (251) 928-3443

Table of Contents

1. Executive Summary
2. Statement of Proposed Change
3. Concurrency Impact Analysis
4. Analysis of the Requirements of Article 12 of the Land Development Regulations

List of Tables

Table 1: Surrounding and Future Land Use and Zoning Designations

Table 2: Concurrency Segment Analysis: US-90 from US-441 to Colburn Avenue

List of Figures

Figure 1: Aerial Map

Figure 2: Existing Future Land Use Map

Figure 3: Existing Zoning Designation

Appendices

Appendix A: FDOT Segment AADT Projections

Appendix B: Historical Tractor Supply Company Water Usage Data

1. EXECUTIVE SUMMARY

City Representative: Robert Angelo, City of Lake City Growth Management

Developer: Ken Fioretti, Hix Snedeker Companies

Engineer: Paul Marcinko, JADE Consulting

Owner: Patricia Faye Boris Revocable Living Trust

Date: June 21, 2023

RE: Tractor Supply Company – Lake City, FL

<p>Jurisdiction: City of Lake City</p>	<p>Intent of Application: To amend the Official Zoning Atlas of the Land Development Regulations by changing the zoning district from Commercial General to Commercial Intensive.</p>
<p>Description of Location: On the south side of E Duval St., west of SE Colburn Ave. and east of NE Chestnut Ave.</p>	
<p>Parcel Numbers: 33-3S-17-13061-000; 33-3S-17-13070-000; 33-3S-17-13079-000; 33-3S-17-13092-000; also including the right-of-way located in the center of these parcels, which was vacated at the June 20, 2023 City Council Meeting, and will be deeded over to the owner from the City.</p>	<p>Acres: ±3.56 acres (AC) <i>Source: Stinson & Associates Survey</i></p>
<p>Existing Zoning District: <i>Commercial General (CG) (±3.56 AC)</i></p> <p>The Commercial General zoning district is intended for general retail commercial, office, and service activities, which serve a market area larger than a neighborhood. Development in CG is limited to a 1.0 FAR.</p>	<p>Proposed Zoning District: <i>Commercial Intensive (CI) (±3.56 AC)</i></p> <p>The Commercial Intensive zoning district is intended for intensive, highly automotive-oriented uses that require a conspicuous and accessible location convenient to streets carrying large volumes of traffic. Development in CI is limited to a 1.0 FAR.</p>
<p>Existing Max. Permitted Intensity: <i>Commercial General (±3.56 AC)</i> ±3.56 AC * 1.0 FAR = ±155,073.60 sq. ft.</p>	<p>Proposed Max. Permitted Intensity: <i>Commercial Intensive (±3.56 AC)</i> ±3.56 AC * 1.0 FAR = ±155,073.60 sq. ft.</p>
<p>Net Change:</p> <p>Amendment of the zoning district from Commercial General to Commercial Intensive. No net change in maximum permitted intensity.</p>	
<p>Criteria for Analysis:</p> <ol style="list-style-type: none"> 1) FDOT 2023 Quality/Level of Service (LOS) Handbook, Generalized Service Volume Table for C4 Context Classification at LOS C for a Four-Lane Roadway 2) Historical Tractor Supply Company Water Usage Data from the City of Lake City, FL 	

2. STATEMENT OF PROPOSED CHANGE

This application requests to change the Official Zoning Atlas of the Land Development Regulations by changing the zoning district classification of ±3.56 acres of land in the City of Lake City from Commercial General to Commercial Intensive. The Columbia County Tax Parcels subject to this application are Tax Parcels: 33-3S-17-13061-000, 33-3S-17-13070-000, 33-3S-17-13079-000, 33-3S-17-13092-000, as well as the existing right-of-way located in the center of these parcels, which was vacated at the June 20, 2023 City Council Meeting, and will be deeded over to the owner from the City, herein after referred to as "the Subject Property". An aerial map is provided as **Figure 1** that shows the site's location and conditions.



Figure 1: Aerial Map

Existing FLU and zoning designations of adjacent parcels are identified in **Table 1** and illustrated in **Figures 2** and **3**, respectively.

Table 1. Surrounding Future Land Use and Zoning Designations

Direction	Future Land Use Designation	Zoning Designation
North	Commercial	Commercial General (City)
South	Residential Medium	Residential, (Conventional) Single Family
East	Commercial	Commercial General (City); Residential, (Conventional) Single Family
West	Commercial; Residential Medium	Commercial General (City)

Figure 2: Existing Future Land Use Map

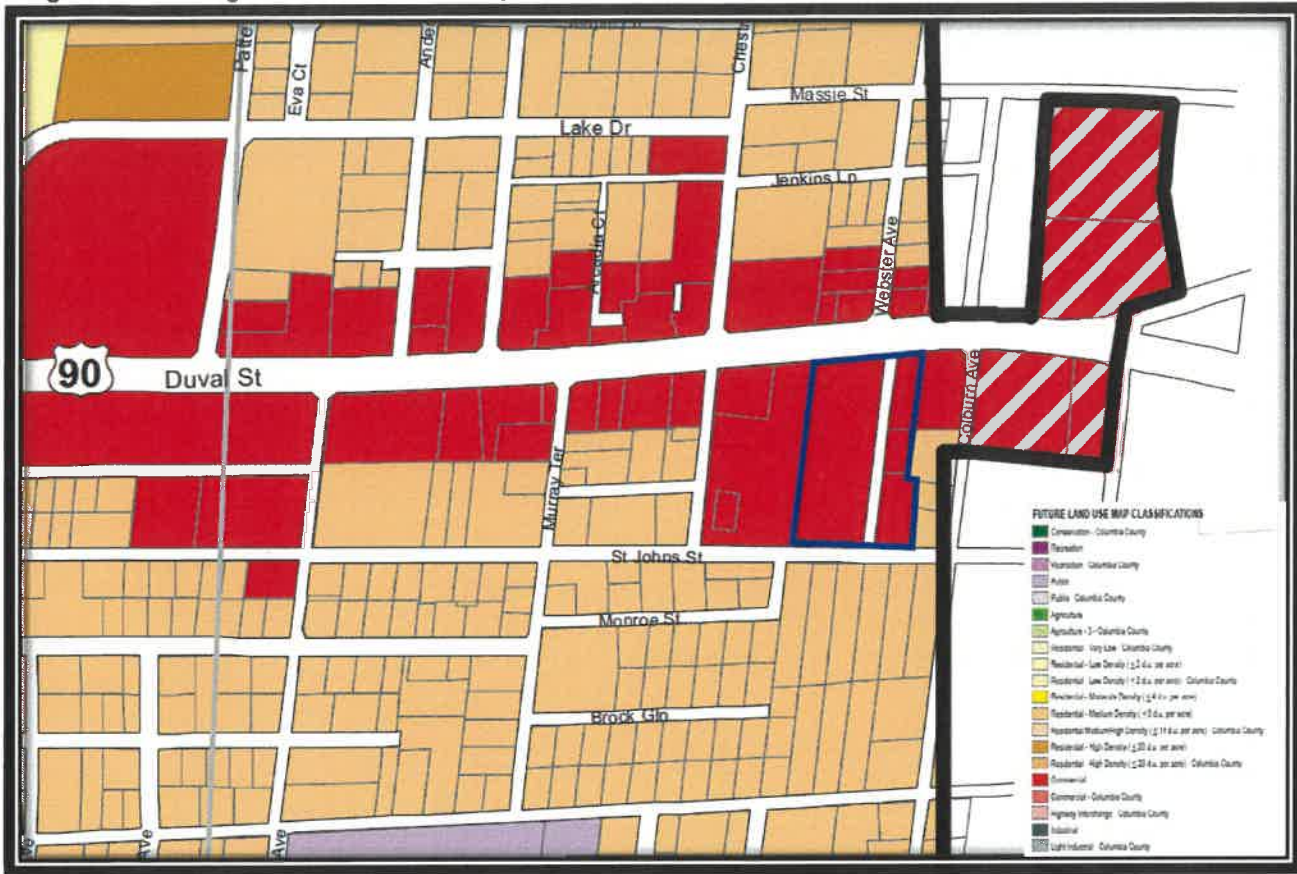
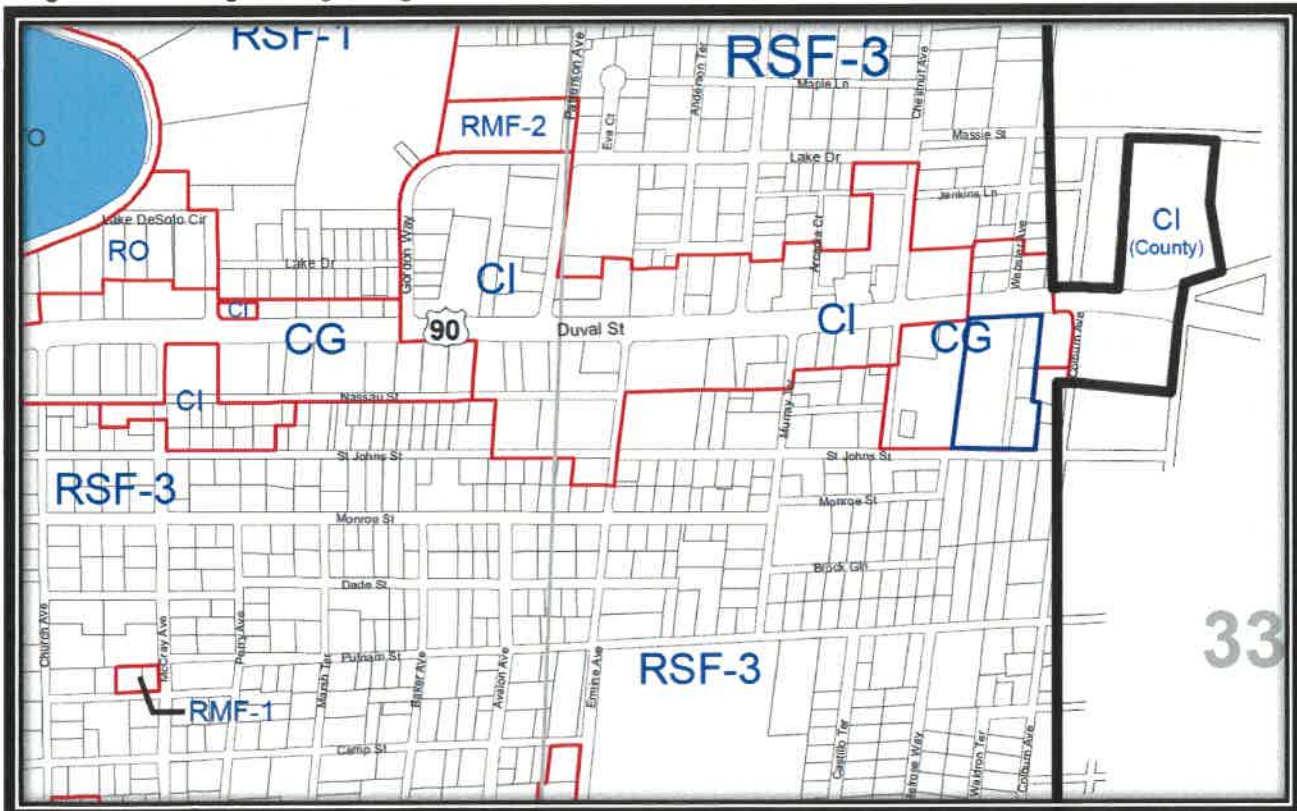

Figure 3: Existing Zoning Designation



3. CONCURRENCY IMPACT ANALYSIS

This Comprehensive Plan Amendment requests to amend the Official Zoning Atlas of the Land Development Regulations by changing the zoning district of the ±3.56-acre property from Commercial General to Commercial Intensive.

The following sections demonstrate the potential impacts of the proposed change on the public facilities, including Transportation, Potable Water, Sanitary Sewer, and Solid Waste in accordance with application requirement D.3.

Potential Transportation Impacts

In accordance with the *City of Lake City Land Development Regulations*, a transportation concurrency analysis was undertaken to determine if there is sufficient roadway capacity along US-90 (E Duval Street) to accommodate the proposed Tractor Supply Company store. Capacity was based on the *FDOT 2023 Quality/Level of Service Handbook*, Generalized Service Volume Tables for C4 context classification at LOS C for a four-lane roadway.

FDOT AADT projections along US-90 (see **Appendix A** for FDOT segment AADT projections) for the year 2027 (the year closest to opening year), and the projected daily site trip assignment along US-90 (E Duval Street), are shown in **Table 2**.

Table 2. Concurrency Segment Analysis: US-90 from US-441 to Colburn Avenue

Year	FDOT AADT	Site Daily Trips	Total with Project	Segment Capacity at LOS C	Without Project LOS	With Project LOS
US-90 from US-441 to Site Driveway #1 (West of the Site)						
Year 2027	14,250	176	14,426	23,180	C	C
US-90 from Site Driveway #1 to Colburn Avenue (East of the Site)						
Year 2027	14,250	176	14,426	23,180	C	C

Conclusion: As shown in **Table 2**, the segment along US-90 is projected to operate under capacity at Level of Service (LOS) C. Therefore, the concurrency LOS standard is met both with and without the project for the year 2027.

Potential Potable Water Impacts

Historical data obtained from the City of Lake City (see **Appendix B**) from the time period of June 2022 – June 2023 for the existing Tractor Supply Company, located at 5359 W US Hwy 90, Lake City, FL 32055, indicated that a total of 288,498 gallons of water was used, however, one month shows an anomaly of 181,740 gallons of usage. From this data, the highest and lowest month's usage was removed, and an average gallons per day usage was generated from the remaining numbers, with the highest month's usage totaling 181,740 gallons, and the lowest month's usage totaling 2,986 gallons. This results in an average expected use of 316.86 gallons per day.

Potential Sanitary Sewer Impacts

Historical data obtained from the City of Lake City (see **Appendix B**) from the time period of June 2022 – June 2023 for the existing Tractor Supply Company, located at 5359 W US Hwy 90, Lake City, FL 32055, indicated that a total of 288,498 gallons of water was used, however, one month shows an anomaly of 181,740 gallons of usage. From this data, the highest and lowest month's usage was removed, and an average gallons per day usage was generated from the remaining numbers, with the highest month's usage totaling 181,740 gallons, and the lowest month's usage totaling 2,986 gallons. This results in an average expected use of 316.86 gallons per day.

Potential Solid Waste Impacts

The Subject Property will not have an impact on the City's solid waste facilities, as it will be served via a private waste management company for solid waste removal.

4. AN ANALYSIS OF THE REQUIREMENTS OF ARTICLE 12 OF THE LAND DEVELOPMENT REGULATIONS

- A) Whether the proposed change would be in conformance with the County's Comprehensive Plan and would have an adverse effect on the County's Comprehensive Plan.**

Analysis: The proposed zoning change is in conformance with the Comprehensive Plan and will not cause any adverse effects to the plan, as outlined herein.

- B) The existing land use pattern.**

Analysis: The Subject Property and surrounding properties have an existing future land use of Commercial and Residential Medium. The parcel to the west that is adjacent to the Subject Property is zoned Commercial General. The parcels to the east that are adjacent to the Subject Property are zoned Commercial General and Residential, (Conventional) Single Family. To the south of the Subject Property, parcels are zoned Residential, (Conventional) Single Family. In addition, the Subject Property is one parcel away, on both the east and west sides, from parcels that are zoned Commercial Intensive (County) and Commercial Intensive (City), respectively.

- C) Possible creation of an isolated district unrelated to adjacent and nearby districts.**

Analysis: As stated in Section B, the Subject Property centrally located between parcels zoned Commercial Intensive, and would not create an isolated district unrelated to adjacent and nearby districts.

- D) The population density pattern and possible increase of overtaxing of the load on public facilities, such as schools, utilities, streets, etc.**

Analysis: The proposed zoning change is in conformance with the Comprehensive Plan, and will not cause any adverse effects to the plan. No additional students in schools will result from the change. The increase in water and sewer will be negligible.

- E) Whether existing district boundaries are illogically drawn in relation to existing conditions on the property proposed for change.**

Analysis: The Subject Property is centrally located between other parcels zoned Commercial Intensive, and does not exist within district boundaries that are illogically drawn.

- F) Whether changed or changing conditions make the passage of the proposed amendment necessary.**

Analysis: All properties in the immediate area fronting US-90 (E Duval Street) have a Future Land Use of Commercial, and are either zoned Commercial General (CG) or Commercial Intensive (CI).

- G) Whether the proposed change will adversely influence living conditions in the neighborhood.**

Analysis: The proposed change will not adversely affect the living conditions in the nearby neighborhood, and traffic from the site will predominantly use US-90 (E Duval Street). The delivery area of the existing development, Save-A-Lot, will be combined with the proposed delivery area of the Tractor Supply Company store to maintain the existing conditions and operations of the site. Therefore the proposed change will not adversely affect the living conditions of the nearby neighborhood, by sharing the impacts of delivery and refuse collection.

H) Whether the proposed change will create or excessively increase traffic congestion or otherwise affect public safety.

Analysis: As noted in the Traffic portion of the Concurrency Impact Analysis, Table 2 shows that the segment along US-90 is projected to operate under capacity at Level of Service (LOS) C. Therefore, the proposed zoning change will not create or excessively increase traffic congestion, or otherwise affect public safety.

I) Whether the proposed change will create a drainage problem.

Analysis: No drainage problems will be created with the zoning change. A portion of the Subject Property currently drains to the FDOT right-of-way, and stormwater management facilities are being designed to meet FDOT 100-year Design Storms, and Level of Service requirements for attenuation and freeboard. St. John's River Water Management District treatment requirements will also be met.

J) Whether the proposed change will seriously reduce light and air to adjacent areas.

Analysis: The site development will not cause a reduction in light or air to adjacent areas.

K) Whether the proposed change will adversely affect property values in the adjacent area.

Analysis: The zoning change will not adversely affect property values in the area. The existing site is undeveloped, with remnants of previous development. The improvements on this property will share an access with the neighboring development, and will reduce the number of driveways along the highway, providing an improved corridor, as well as improved site conditions.

L) Whether the proposed change will be a deterrent to the improvement or development of adjacent property in accordance with existing regulations.

Analysis: As the Subject Property is surrounded by other properties zoned Commercial Intensive (CI), the proposed zoning change will not be a deterrent to the improvement or development of adjacent properties, in accordance with existing regulations.

M) Whether the proposed change will constitute a grant of special privilege to an individual or owner, as contrasted with the public welfare.

Analysis: The proposed zoning change will not grant special privileges to the owner, as it is situated closely to other properties zoned Commercial Intensive (CI).

N) Whether there are substantial reasons why the property cannot be used in accordance with the existing zoning.

Analysis: Current zoning, Commercial General, does not allow for the sale of ATVs, UTVs, and equipment, which is a standard development feature of the nationally recognized retailer, Tractor Supply Company, nor does it allow outdoor display areas. Rezoning to Commercial Intensive will allow for these sales and display areas, and aligns with nearby zoning patterns.

O) Whether the change suggested is out of scale with the needs of the neighborhood or the City.

Analysis: The proposed zoning change is in line with the needs of the City.

P) Whether it is impossible to find other adequate sites in the city for the proposed use in districts already permitting such use. Then pertaining to other proposed amendments of these land development regulations. The Planning & Zoning Board shall consider and study:

- a. The need and justification for the change.
- b. The relationship of the proposed amendment to the purposes and objectives of the comprehensive planning program and to the City's comprehensive plan, with appropriate consideration as to whether the proposed change will further the purposes of these land development regulations and other ordinances, regulations, and actions designed to implement the City's comprehensive plan.

Analysis: The developer has conducted extensive market research in the Lake City area, and has determined that the Subject Property provides adequate acreage for the selected development at the most reasonable price-point. Rezoning this property from Commercial General to Commercial Intensive will make possible the reasonable use of the land, and will be in harmony with the general intent and purpose of the Land Development Regulations of the City of Lake City, FL.

APPENDIX A

FDOT Segment AADT Projection



ALL TRAFFIC DATA SERVICES

(303) 216-2439

www.alltrafficdata.net

Location: 1 CHESTNUT AVENUE & DUVAL ROAD /

Date: Tuesday, May 16, 2023

Peak Hour: 07:15 AM - 08:15 AM

Peak 15-Minutes: 07:30 AM - 07:45 AM

Peak Hour - Motorized Vehicles

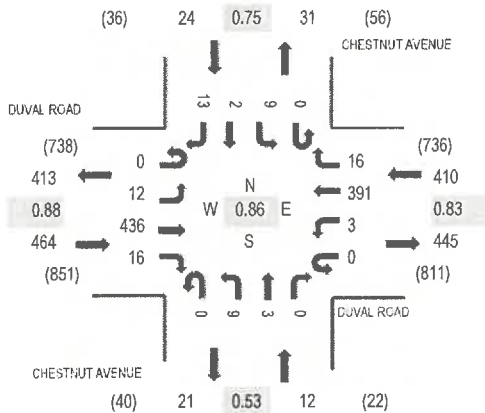

Peak Hour - Bicycles

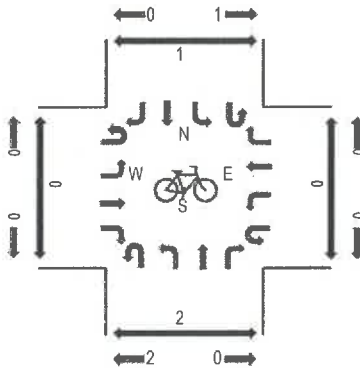

Peak Hour - Pedestrians

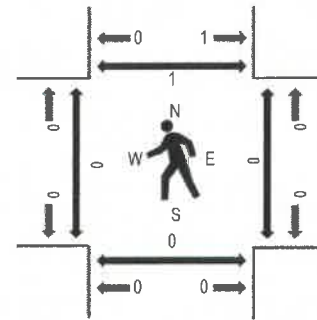

Note: Total study counts contained in parentheses.

Traffic Counts - Motorized Vehicles

Interval Start Time	DUVAL ROAD Eastbound				DUVAL ROAD Westbound				CHESTNUT AVENUE Northbound				CHESTNUT AVENUE Southbound				Total	Rolling Hour	Pedestrian Crossings			
	U-Turn	Left	Thru	Right	U-Turn	Left	Thru	Right	U-Turn	Left	Thru	Right	U-Turn	Left	Thru	Right			West	East	South	North
7:00 AM	0	1	99	0	0	0	71	3	0	0	1	0	0	1	0	0	176	889	0	0	0	1
7:15 AM	0	3	119	2	0	0	102	6	0	0	0	0	0	4	0	3	239	910	0	0	0	0
7:30 AM	0	3	127	2	0	0	120	3	0	2	1	0	0	2	0	6	256	853	0	0	0	0
7:45 AM	0	5	93	5	0	1	92	6	0	1	0	0	0	2	1	2	208	787	0	0	0	0
8:00 AM	0	1	97	7	0	2	77	1	0	6	2	0	0	1	1	2	197	756	0	0	0	1
8:15 AM	0	6	96	3	0	1	66	1	0	4	0	0	0	1	2	2	182		0	0	0	0
8:30 AM	0	2	75	6	0	1	87	4	0	0	0	2	0	0	0	3	180		0	0	0	0
8:45 AM	0	3	90	6	0	0	90	2	0	0	2	1	0	1	0	2	197		0	0	0	1

Peak Rolling Hour Flow Rates

Vehicle Type	Eastbound				Westbound				Northbound				Southbound				Total
	U-Turn	Left	Thru	Right	U-Turn	Left	Thru	Right	U-Turn	Left	Thru	Right	U-Turn	Left	Thru	Right	
Articulated Trucks	0	0	13	2	0	0	11	0	0	0	0	0	0	0	0	0	26
Lights	0	12	406	14	0	3	371	16	0	8	3	0	0	9	2	13	857
Mediums	0	0	17	0	0	0	9	0	0	1	0	0	0	0	0	0	27
Total	0	12	436	16	0	3	391	16	0	9	3	0	0	9	2	13	910

Heavy Vehicle Percentage and Peak Hour Factor

	Eastbound				Westbound				Northbound				Southbound				Total
	U-Turn	Left	Thru	Right	U-Turn	Left	Thru	Right	U-Turn	Left	Thru	Right	U-Turn	Left	Thru	Right	
Heavy Vehicle %	6.9%				4.9%				8.3%				0.0%				5.8%
Heavy Vehicle %	0.0%	0.0%	6.9%	12.5%	0.0%	0.0%	5.1%	0.0%	0.0%	11.1%	0.0%	0.0%	0.0%	0.0%	0.0%	0.0%	5.8%
Peak Hour Factor	0.88				0.83				0.53				0.75				0.86
Peak Hour Factor	0.00	0.63	0.86	0.79	0.00	0.63	0.81	0.75	0.00	0.54	0.50	0.38	0.00	0.56	0.50	0.54	0.86



ALL TRAFFIC DATA SERVICES

(303) 216-2439
www.alltrafficdata.net

Location: 1 CHESTNUT AVENUE & DUVAL ROAD

Date: Tuesday, May 16, 2023

Peak Hour: 04:15 PM - 05:15 PM

Peak 15-Minutes: 04:30 PM - 04:45 PM

Peak Hour - Motorized Vehicles

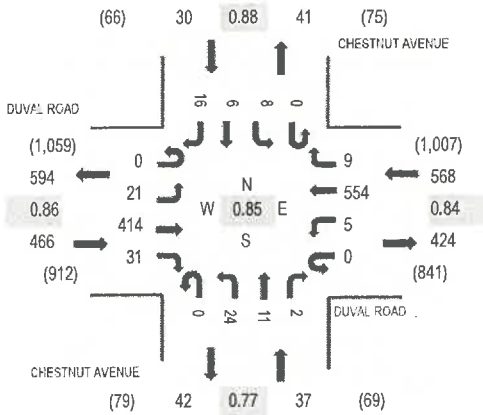

Peak Hour - Bicycles

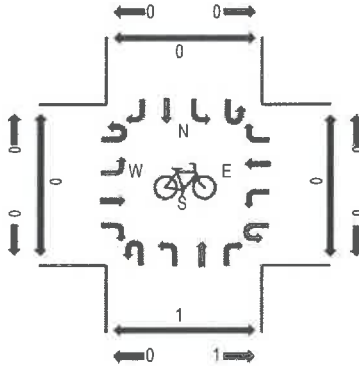

Peak Hour - Pedestrians

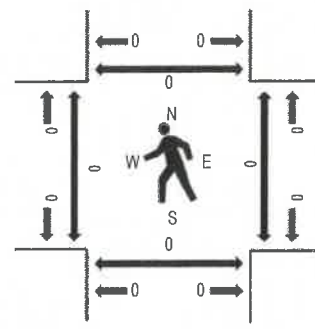

Note: Total study counts contained in parentheses.

Traffic Counts - Motorized Vehicles

Interval Start Time	DUVAL ROAD Eastbound				DUVAL ROAD Westbound				CHESTNUT AVENUE Northbound				CHESTNUT AVENUE Southbound				Total	Rolling Hour	Pedestrian Crossings			
	U-Turn	Left	Thru	Right	U-Turn	Left	Thru	Right	U-Turn	Left	Thru	Right	U-Turn	Left	Thru	Right			West	East	South	North
4:00 PM	0	4	106	9	0	2	130	3	0	6	2	0	0	2	2	6	272	1,089	0	0	1	0
4:15 PM	0	8	90	7	0	0	137	1	0	9	2	1	0	4	0	6	285	1,101	0	0	0	0
4:30 PM	0	5	125	8	0	3	161	5	0	5	2	0	0	3	3	2	323	1,080	0	0	0	0
4:45 PM	0	3	80	5	0	2	124	2	0	5	1	0	0	0	2	5	229	1,000	0	0	0	0
5:00 PM	0	5	119	11	0	0	132	0	0	5	6	1	0	1	1	3	284	965	0	0	0	0
5:15 PM	0	3	105	5	0	1	109	3	0	8	0	2	0	4	1	3	244		0	1	1	0
5:30 PM	0	4	107	5	0	2	103	2	0	6	2	1	0	3	3	5	243		0	0	0	0
5:45 PM	0	7	87	4	0	0	81	3	0	4	1	0	0	0	3	4	194		0	0	0	0

Peak Rolling Hour Flow Rates

Vehicle Type	Eastbound				Westbound				Northbound				Southbound				Total
	U-Turn	Left	Thru	Right	U-Turn	Left	Thru	Right	U-Turn	Left	Thru	Right	U-Turn	Left	Thru	Right	
Articulated Trucks	0	0	11	0	0	0	14	0	0	0	0	0	0	0	0	0	25
Lights	0	21	397	31	0	5	535	9	0	24	11	2	0	8	6	16	1,065
Mediums	0	0	6	0	0	0	5	0	0	0	0	0	0	0	0	0	11
Total	0	21	414	31	0	5	554	9	0	24	11	2	0	8	6	16	1,101

Heavy Vehicle Percentage and Peak Hour Factor

	Eastbound				Westbound				Northbound				Southbound				Total
	U-Turn	Left	Thru	Right	U-Turn	Left	Thru	Right	U-Turn	Left	Thru	Right	U-Turn	Left	Thru	Right	
Heavy Vehicle %	3.6%				3.3%				0.0%				0.0%				3.3%
Heavy Vehicle %	0.0%	0.0%	4.1%	0.0%	0.0%	0.0%	3.4%	0.0%	0.0%	0.0%	0.0%	0.0%	0.0%	0.0%	0.0%	0.0%	3.3%
Peak Hour Factor	0.86				0.84				0.77				0.88				0.85
Peak Hour Factor	0.00	0.66	0.86	0.70	0.00	0.58	0.86	0.50	0.00	0.69	0.46	0.50	0.00	0.56	0.67	0.79	0.85

Site Code: 1
Station ID: 1
ST JOHN STREET WEST OF
COLBURN AVENUE

Start Time	16-May-23 Tue	EB		Hour Totals		WB		Hour Totals		Combined Totals	
		Morning	Afternoon	Morning	Afternoon	Morning	Afternoon	Morning	Afternoon	Morning	Afternoon
12:00		0	2			0	3				
12:15		0	3			0	4				
12:30		0	4			0	4				
12:45		0	4	0	13	0	2	0	13	0	26
01:00		0	2			0	4				
01:15		0	4			0	3				
01:30		0	2			0	4				
01:45		0	4	0	12	0	4	0	15	0	27
02:00		0	6			0	6				
02:15		0	4			0	4				
02:30		0	6			0	4				
02:45		0	1	0	17	1	0	1	14	1	31
03:00		0	4			0	1				
03:15		0	1			0	2				
03:30		1	3			0	3				
03:45		0	4	1	12	0	4	0	10	1	22
04:00		0	4			0	5				
04:15		0	4			0	4				
04:30		0	5			0	3				
04:45		0	2	0	15	0	3	0	15	0	30
05:00		0	3			0	6				
05:15		0	1			0	1				
05:30		0	2			2	3				
05:45		0	2	0	8	1	5	3	15	3	23
06:00		1	4			2	4				
06:15		1	4			0	2				
06:30		0	1			0	3				
06:45		1	3	3	12	1	2	3	11	6	23
07:00		3	5			4	2				
07:15		3	2			3	5				
07:30		3	2			2	3				
07:45		0	6	9	15	3	3	12	13	21	28
08:00		0	2			3	1				
08:15		2	4			3	2				
08:30		2	0			4	0				
08:45		1	1	5	7	0	1	10	4	15	11
09:00		2	2			0	1				
09:15		2	0			1	0				
09:30		1	2			2	1				
09:45		3	2	8	6	2	2	5	4	13	10
10:00		2	1			2	0				
10:15		4	2			2	1				
10:30		6	0			5	1				
10:45		5	3	17	6	5	1	14	3	31	9
11:00		2	0			3	1				
11:15		2	0			4	0				
11:30		3	1			4	0				
11:45		0	0	7	1	2	0	13	1	20	2
Total		50	124			61	118			111	242
Percent		28.7%	71.3%			34.1%	65.9%			31.4%	68.6%
Grand Total		50	124			61	118			111	242
Percent		28.7%	71.3%			34.1%	65.9%			31.4%	68.6%

ADT

ADT 353

AADT 353

2022 PEAK SEASON FACTOR CATEGORY REPORT - REPORT TYPE: ALL
 CATEGORY: 2900 COLUMBIA COU WIDE

MOCF: 0.98

WEEK	DATES	SF	PSCF
1	01/01/2022 - 01/01/2022	1.02	1.04
2	01/02/2022 - 01/08/2022	1.05	1.07
3	01/09/2022 - 01/15/2022	1.08	1.10
4	01/16/2022 - 01/22/2022	1.07	1.09
5	01/23/2022 - 01/29/2022	1.05	1.07
6	01/30/2022 - 02/05/2022	1.03	1.05
7	02/06/2022 - 02/12/2022	1.02	1.04
8	02/13/2022 - 02/19/2022	1.00	1.02
9	02/20/2022 - 02/26/2022	1.00	1.02
10	02/27/2022 - 03/05/2022	0.99	1.01
11	03/06/2022 - 03/12/2022	0.99	1.01
*12	03/13/2022 - 03/19/2022	0.98	1.00
*13	03/20/2022 - 03/26/2022	0.98	1.00
*14	03/27/2022 - 04/02/2022	0.98	1.00
*15	04/03/2022 - 04/09/2022	0.97	0.99
*16	04/10/2022 - 04/16/2022	0.97	0.99
*17	04/17/2022 - 04/23/2022	0.97	0.99
*18	04/24/2022 - 04/30/2022	0.97	0.99
*19	05/01/2022 - 05/07/2022	0.97	0.99
*20	05/08/2022 - 05/14/2022	0.97	0.99
*21	05/15/2022 - 05/21/2022	0.98	1.00
*22	05/22/2022 - 05/28/2022	0.98	1.00
*23	05/29/2022 - 06/04/2022	0.99	1.01
*24	06/05/2022 - 06/11/2022	0.99	1.01
25	06/12/2022 - 06/18/2022	1.00	1.02
26	06/19/2022 - 06/25/2022	1.00	1.02
27	06/26/2022 - 07/02/2022	1.01	1.03
28	07/03/2022 - 07/09/2022	1.02	1.04
29	07/10/2022 - 07/16/2022	1.03	1.05
30	07/17/2022 - 07/23/2022	1.02	1.04
31	07/24/2022 - 07/30/2022	1.01	1.03
32	07/31/2022 - 08/06/2022	1.01	1.03
33	08/07/2022 - 08/13/2022	1.00	1.02
34	08/14/2022 - 08/20/2022	0.99	1.01
35	08/21/2022 - 08/27/2022	1.00	1.02
36	08/28/2022 - 09/03/2022	1.00	1.02
37	09/04/2022 - 09/10/2022	1.01	1.03
38	09/11/2022 - 09/17/2022	1.01	1.03
39	09/18/2022 - 09/24/2022	1.00	1.02
40	09/25/2022 - 10/01/2022	0.99	1.01
41	10/02/2022 - 10/08/2022	0.98	1.00
42	10/09/2022 - 10/15/2022	0.97	0.99
43	10/16/2022 - 10/22/2022	0.98	1.00
44	10/23/2022 - 10/29/2022	0.99	1.01
45	10/30/2022 - 11/05/2022	1.00	1.02
46	11/06/2022 - 11/12/2022	1.01	1.03
47	11/13/2022 - 11/19/2022	1.02	1.04
48	11/20/2022 - 11/26/2022	1.02	1.04
49	11/27/2022 - 12/03/2022	1.02	1.04
50	12/04/2022 - 12/10/2022	1.02	1.04
51	12/11/2022 - 12/17/2022	1.02	1.04
52	12/18/2022 - 12/24/2022	1.05	1.07
53	12/25/2022 - 12/31/2022	1.08	1.10

* PEAK SEASON

23-FEB-2023 09:11:19

830UPD

2_2900_PKSEASON.TXT



US 90 from US 441 to Colburn Ave

Attribute	Value
Segment ID:	193
Segment Length (miles):	1.033 mi
Location:	Lake City
County:	Columbia
Roadway ID:	29010000
Begin MP:	10.055
End MP:	11.088
SIS:	No
SIS Type:	Non SIS
Median Treatment:	Divided
Directionality:	Two-Way
Posted Speed:	45 mph
Facility Type:	Arterial
Area Type:	Transition
FDOT LOS Standard:	C
Max. Service Vol. Adj. Factor:	0.00



Data Sources: RCI; TCI; NERPM AB; GUATS; FLSWM
 Google Street View:
<http://maps.google.com/maps?z=8&layer=c&cbll=30.1892984985974,-82.6284216083561>

Projected Values	2021	2027	2030	2035	2040	2045
Number of Lanes	4	4	4	4	4	4
AADT	13,532	14,250	14,646	15,306	15,965	16,625
Peak Hour Maximum Service Volume at LOS Standard	3,060	3,060	3,060	3,060	3,060	3,060
Peak Hour Traffic Volume	1,218	1,283	1,318	1,378	1,437	1,496
Peak Hour LOS	C	C	C	C	C	C

Notes:



APPENDIX B

Historical Tractor Supply Company Water Usage Data

From: [Pelham, Shasta](#)
To: [Sarah Moore](#)
Cc: [Paul Marcinko](#); [Thomas Luce](#); [Medearis, Katrina](#); [McGhin, Brandy](#)
Subject: RE: Tractor Supply Company - Historical Water Usage - Lake City, FL
Date: Friday, June 16, 2023 7:20:31 AM
Attachments: [image002.png](#)
[image003.png](#)

Good Morning,

The requested consumption history is shown below.

Consumption Information	GAL
06/06/2023	17,328
05/09/2023	9,264
04/04/2023	9,589
03/07/2023	5,919
02/07/2023	101,740
01/10/2023	4,817
12/06/2022	9,402
11/08/2022	5,358
10/04/2022	2,966
09/08/2022	8,508
08/09/2022	3,735
07/05/2022	9,107
06/07/2022	20,745
Total	288,498

***The highest and lowest usage numbers were struck from this list, and an average of the remaining numbers was used to generate gallons per day.

Shasta M. Pelham
Utility Service Coordinator
173 NW Hillsboro St.
Lake City, FL 32055
pelhams@lcfla.com
Phone: (386) 719-5786



PLEASE NOTE: Florida has a very broad public records law. Most written communications to or from City officials regarding City business are public records available to the public and media upon

request. Your email communications may be subject to public disclosure.

From: Sarah Moore <smoore@jadengineers.com>
Sent: Thursday, June 15, 2023 4:59 PM
To: Pelham, Shasta <PelhamS@lcfla.com>
Cc: Paul Marcinko <pmarcinko@jadengineers.com>; Thomas Luce <tluce@jadengineers.com>
Subject: Tractor Supply Company - Historical Water Usage - Lake City, FL

Hi Shasta,

I am working on the Concurrency Impact Analysis required for the rezoning of our property on which the new Tractor Supply Company will be located.

There is another Tractor Supply Company store on the west side of town, located at 5359 W US Hwy 90, Lake City, FL 32055, and I was wondering if it is possible to pull some historical data on the water usage for that location that I could use as supporting documentation for our concurrency analysis. Please let me know if this is possible, and thank you for your help!

Sarah Moore



JADE Consulting, LLC

208 Greeno Road North, Suite C (36532)

P.O. Box 1929

Fairhope, AL 36533

smoore@JADEngineers.com

251.422.6744 (cell)

251.928.3443 (office)

251.928.3665 (fax)

CONFIDENTIALITY NOTICE- The information contained in this e-mail and any attachments to it may be legally privileged and include confidential information. If you are not the intended recipient, be aware that any disclosure, distribution or copying of this e-mail or its attachments is prohibited. If you have received this e-mail in error, please notify the sender immediately of that fact by return e-mail and permanently delete the e-mail and any attachments to it.

USE OF DIGITAL FILES: Any digital files attached to this transmission have been provided for your convenience. JADE Consulting, LLC. makes no express or implied warranties as to its suitability of the attached electronic files for any specific purpose. Although we believe the attached files to be accurate and safe at the time of transfer these files can be easily changed or corrupted. Therefore, it is the user's responsibility to examine these electronic files for corruption or virus contamination prior to use. Coordination for updates is the responsibility of the recipient. We are also not responsible to the recipient or any other users allowed by the recipient to employ this data for updating the files or for compatibility with the user's hardware and/or software.

LEGAL DESCRIPTION (TAKEN FROM TITLE COMMITMENT NO. 7222-6391623, DATED 04/01/2023 @ 8:00 AM; ISSUING AGENT: PENNINGTON, P.A.)

The Land referred to herein below is situated in the County of COLUMBIA, State of Florida, and is described as follows:

PARCEL 1:
33-3S-17-13061-000

COMMENCE AT THE INTERSECTION OF THE SOUTH LINE OF DUVAL STREET AND THE WEST LINE OF COLBURN AVENUE, SAID COLBURN AVENUE BEING 30 FEET IN WIDTH, AND RUN WEST ALONG THE SOUTH LINE OF SAID DUVAL STREET, A DISTANCE OF 212.5 FEET FOR A POINT OF BEGINNING; RUN SOUTH 07 DEG. 48 MIN. WEST, 527 FEET TO THE NORTH LINE OF ST. JOHNS STREET; RUN NORTH 88 DEG. 35 MIN. WEST ALONG THE NORTH LINE OF SAID ST. JOHNS STREET, 211 FEET; RUN NORTH 07 DEG. 40 MIN. EAST, 508 FEET TO THE SOUTH LINE OF DUVAL STREET; RUN NORTH 86 DEG. 16 MIN. EAST ALONG THE SOUTH LINE OF SAID DUVAL STREET, 212.5 FEET TO THE POINT OF BEGINNING; SAID LANDS BEING BOUNDED ON THE WEST BY LAND FORMERLY OWNED BY C. B. MESSER AND KNOWN AS DUVAL TOURIST CAMP, ALL OF THE ABOVE DESCRIBED LANDS LYING AND BEING WHOLLY WITHIN THE SOUTHEAST 1/4 OF THE NORTHWEST 1/4 OF SECTION 33, TOWNSHIP 3 SOUTH, RANGE 17 EAST, COLUMBIA COUNTY, FLORIDA.

LESS ADDITIONAL RIGHT OF WAY FOR STATE ROAD 10 (US 90) PER OR BOOK 772, PAGE 1800 OF THE PUBLIC RECORDS OF COLUMBIA COUNTY, FLORIDA.

PARCEL 2:
33-3S-17-13070-000

COMMENCE AT THE SOUTH LINE OF DUVAL STREET AT ITS INTERSECTION WITH THE WEST LINE OF COLBURN AVENUE AND RUN SOUTH 86 DEG. 16 MIN. WEST ALONG THE SOUTH LINE OF DUVAL STREET, A DISTANCE OF 127.3 FEET FOR A POINT OF BEGINNING; AND THENCE RUN SOUTH 86 DEG. 16 MIN. WEST ALONG THE SOUTH LINE OF DUVAL STREET A DISTANCE OF 70 FEET; THENCE RUN SOUTH 07 DEG. 48 MIN. WEST ALONG THE EAST LINE OF WALDRON STREET, A DISTANCE OF 170 FEET; THENCE RUN NORTH 86 DEG. 16 MIN. EAST, 70 FEET; THENCE RUN NORTH 07 DEG. 48 MIN. EAST, 170 FEET TO THE SOUTH LINE OF DUVAL STREET AND THE POINT OF BEGINNING. ALL LYING AND BEING IN SECTION 33, TOWNSHIP 3 SOUTH, RANGE 17 EAST, COLUMBIA COUNTY, FLORIDA.

LESS ADDITIONAL RIGHT OF WAY FOR STATE ROAD 10 (US 90) PER OR BOOK 772, PAGE 1798, OF THE PUBLIC RECORDS OF COLUMBIA COUNTY, FLORIDA.

ALSO:

A PARCEL OF LAND LYING IN THE SOUTHEAST 1/4 OF THE NORTHWEST 1/4 OF SECTION 33, TOWNSHIP 3 SOUTH, RANGE 17 EAST, LAKE CITY, FLORIDA, BEING MORE PARTICULARLY DESCRIBED AS FOLLOWS:

COMMENCE AT THE INTERSECTION OF THE SOUTH RIGHT OF WAY LINE OF DUVAL STREET (U.S. HIGHWAY NO. 90) AND THE EAST RIGHT OF WAY LINE OF WALDRON STREET AND RUN SOUTH 08 DEG. 41 MIN. 21 SEC. WEST ALONG SAID EAST RIGHT OF WAY LINE OF WALDRON STREET, 170.49 FEET TO THE POINT OF BEGINNING; THENCE RUN NORTH 88 DEG. 48 MIN. 31 SEC. EAST, A DISTANCE OF 70.97 FEET; THENCE RUN SOUTH 08 DEG. 48 MIN. 58 SEC. WEST, A DISTANCE OF 44.11 FEET; THENCE RUN NORTH 88 DEG. 00 MIN. 52 SEC. WEST, A DISTANCE OF 69.83 FEET TO THE EAST RIGHT OF WAY LINE OF WALDRON STREET; THENCE RUN NORTH 08 DEG. 41 MIN. 21 SEC. WEST ALONG SAID EAST RIGHT OF WAY LINE 37.65 FEET TO THE POINT OF BEGINNING.

PARCEL 4:
33-3S-17-13092-000

COMMENCE AT THE SOUTH LINE OF DUVAL STREET AT ITS INTERSECTION WITH THE EAST LINE OF WALDRON STREET AND RUN SOUTH ALONG THE EAST LINE OF WALDRON STREET FOR A POINT OF BEGINNING, A DISTANCE OF 207.83 FEET; THENCE SOUTH ALONG THE SAID EAST LINE OF WALDRON STREET A DISTANCE OF 120 FEET; THENCE EAST ALONG A LINE PARALLEL WITH THE NORTH LINE OF EAST ST. JOHNS STREET, A DISTANCE OF 100 FEET; THENCE NORTH ALONG A LINE PARALLEL WITH THE EAST LINE OF WALDRON STREET, A DISTANCE OF 120 FEET; THENCE WEST ALONG A LINE PARALLEL WITH THE NORTH LINE OF EAST ST. JOHNS STREET, A DISTANCE OF 100 FEET TO THE POINT OF BEGINNING. SAID LANDS LYING AND BEING WHOLLY WITHIN THE SOUTHEAST 1/4 OF THE NORTHWEST 1/4 OF SECTION 33, TOWNSHIP 3 SOUTH, RANGE 17 EAST, COLUMBIA COUNTY, FLORIDA.

LESS AND EXCEPT:

COMMENCE AT THE INTERSECTION OF THE SOUTH RIGHT OF WAY LINE OF DUVAL STREET (U.S. HIGHWAY NO. 90) AND THE EAST RIGHT OF WAY LINE OF WALDRON STREET AND RUN SOUTH 08 DEG. 41 MIN. 21 SEC. WEST ALONG THE EAST RIGHT OF WAY LINE OF WALDRON STREET, 208.14 FEET; THENCE RUN SOUTH 88 DEG. 00 MIN. 52 SEC. EAST, A DISTANCE OF 69.83 FEET TO THE POINT OF BEGINNING; THENCE CONTINUE SOUTH 88 DEG. 00 MIN. 52 SEC. EAST, A DISTANCE OF 30.00 FEET; THENCE RUN SOUTH 08 DEG. 36 MIN. 19 SEC. WEST, A DISTANCE OF 137.72 FEET; THENCE RUN NORTH 81 DEG. 53 MIN. 00 SEC. WEST, A DISTANCE OF 30.30 FEET; THENCE RUN NORTH 08 DEG. 48 MIN. 58 SEC. EAST, A DISTANCE OF 134.52 FEET TO THE POINT OF BEGINNING.

PARCEL 6:
33-35-17-13079-000

COMMENCE AT THE INTERSECTION OF THE WEST LINE OF COLBURN STREET AND THE NORTH LINE OF ST. JOHNS STREET AND RUN NORTH 88 DEG. 52 MIN. WEST, ALONG THE NORTH LINE OF SAID ST. JOHNS STREET, 95.85 FEET FOR POINT OF BEGINNING; RUN NORTH 88 DEG. 52 MIN. WEST, 100 FEET; RUN NORTH 07 DEG. 48 MIN. EAST, ALONG THE EAST LINE OF WALDRON STREET, 200 FEET; RUN SOUTH 88 DEG. 52 MIN. EAST, 100 FEET; RUN SOUTH 07 DEG. 48 MIN. WEST, 200 FEET TO THE POINT OF BEGINNING, SAID LANDS BEING WHOLLY WITHIN THE SOUTHEAST 1/4 OF THE NORTHWEST 1/4 OF SECTION 33, TOWNSHIP 3 SOUTH, RANGE 17 EAST, COLUMBIA COUNTY, FLORIDA.

LESS AND EXCEPT BOOK 1293, PAGE 1291

BEING FURTHER DESCRIBED AS FOLLOWS AND BEING BASED ON RECENT FIELD SURVEY, PERFORMED BY S. STINSON & ASSOCIATES, INC., DATED MAY 3, 2023:

COMMENCE AT A FOUND 4"X4" CONCRETE MONUMENT MARKING THE INTERSECTION OF THE WESTERLY RIGHT-OF-WAY BOUNDARY OF SE COLBURN AVENUE AND THE NORTHERLY RIGHT-OF-WAY BOUNDARY OF SE ST. JOHNS STREET, THENCE RUN ALONG THE NORTHERLY RIGHT-OF-WAY BOUNDARY OF SAID SE ST. JOHNS STREET NORTH 89 DEGREES 54 MINUTES 19 SECONDS WEST 95.53 FEET TO A FOUND 4"X4" CONCRETE MONUMENT MARKING THE POINT OF BEGINNING.

THENCE FROM SAID POINT OF BEGINNING AND LEAVING THE NORTHERLY RIGHT-OF-WAY OF SAID SE SAINT JOHNS STREET RUN NORTH 06 DEGREES 13 MINUTES 11 SECONDS EAST 181.58 FEET TO A SET 5/8" IRON ROD AND CAP (LB #8393) MARKING THE NORTHWEST CORNER OF THAT PARCEL BEING DESCRIBED IN OFFICIAL RECORDS BOOK 821, PAGE 1822 OF THE PUBLIC RECORDS OF COLUMBIA COUNTY, FLORIDA; THENCE NORTH 83 DEGREES 03 MINUTES 50 SECONDS WEST 28.59 FEET TO A FOUND 4"X4" CONCRETE MONUMENT MARKING THE SOUTHWEST CORNER OF THAT PARCEL BEING DESCRIBED IN OFFICIAL RECORDS BOOK 1293, PAGE 1291 OF THE AFORESAID PUBLIC RECORDS; THENCE ALONG THE WEST BOUNDARY OF SAID PARCEL RUN NORTH 06 DEGREES 55 MINUTES 27 SECONDS EAST 348.35 FEET TO A FOUND 5/8" IRON ROD AND CAP (LB #7042) MARKING A POINT OF INTERSECTION WITH THE SOUTHERLY RIGHT-OF-WAY BOUNDARY OF STATE ROAD NO. 10 (E DUVAL STREET); THENCE ALONG SAID SOUTHERLY RIGHT-OF-WAY RUN SOUTH 85 DEGREES 43 MINUTES 13 SECONDS WEST 55.94 FEET TO A SET 5/8" IRON ROD AND CAP (LB #8393); THENCE SOUTH 46 DEGREES 15 MINUTES 38 SECONDS WEST 23.40 FEET TO A SET PK NAIL AND DISK (LB #8393); THENCE SOUTH 84 DEGREES 47 MINUTES 48 SECONDS WEST 28.11 FEET TO A SET 5/8" IRON ROD AND CAP (LB #8393); THENCE NORTH

43 DEGREES 57 MINUTES 40 SECONDS WEST 18.86 FEET TO A SET PK NAIL AND DISK (LB #8393); THENCE SOUTH 84 DEGREES 53 MINUTES 05 SECONDS WEST 184.06 FEET TO A SET 5/8" IRON ROD AND CAP (LB #8393); THENCE LEAVING THE SOUTHERLY RIGHT-OF-WAY BOUNDARY OF SAID STATE ROAD NO. 10 RUN SOUTH 06 DEGREES 08 MINUTES 42 SECONDS WEST 506.10 FEET TO A FOUND X-CUT IN CONCRETE MARKING A POINT OF INTERSECTION WITH THE NORTHERLY RIGHT-OF-WAY BOUNDARY OF SAID SE SAINT JOHNS STREET; THENCE ALONG SAID RIGHT-OF-WAY RUN SOUTH 89 DEGREES 49 MINUTES 15 SECONDS EAST 187.62 FEET TO A FOUND 5/8" IRON ROD; THENCE NORTH 89 DEGREES 49 MINUTES 54 SECONDS EAST 30.00 FEET TO A FOUND 4"X4" CONCRETE MONUMENT; THENCE CONTINUE ALONG SAID NORTHERLY RIGHT-OF-WAY SOUTH 89 DEGREES 48 MINUTES 11 SECONDS EAST 100.37 FEET TO THE POINT OF BEGINNING, CONTAINING 3.56 ACRES, MORE OR LESS, AND LYING WHOLLY IN SECTION 33, TOWNSHIP 3 SOUTH, RANGE 17 EAST, COLUMBIA COUNTY, FLORIDA.

Warranty Deed

This instrument prepared by and return to:
Gary D. Grunder
Attorney at Law
23349 Northwest CR 236, Suite 10
High Springs, Florida 32643

Inst:2007011637 Date:05/24/2007 Time:14:29
Doc Stamp-Deed : 0.70
GDG DC, P. DeWitt Cason, Columbia County B:1120 P:405

Tax Identification # See each Parcel description

This Indenture made this 16th day of May, 2007 by

Patricia Faye Boris, an unmarried widow, whose post office address is P.O. Box 2095, Lake City, Florida 32056, GRANTOR, and

Patricia Faye Boris as Trustee of The Patricia Faye Boris Revocable Living Trust Dated September 14, 2005 whose post office address is P.O. Box 2095, Lake City, Florida 32056, GRANTEE.

Witnesseth that said Grantor, for and in consideration of the sum of TEN AND NO/100 (\$10.00) Dollars and other good and valuable considerations to said Grantor in hand paid by said Grantee, the receipt whereof is hereby acknowledged, has granted, bargained and sold to the said Grantee, and Grantee's heirs and assigns forever, the following described land, situate, lying and being in Columbia County, Florida, to-wit:

Parcel 1: Corporate Offices, Parcel No.: R07087-000:

Lots 4, 5, 16 and 17 of Block 21, Country Club Estates, a subdivision according to Map or Plat thereof on file in the office of the Clerk of the Circuit Court, Columbia County, Florida, in Plat Book 1, Page 7, Public Records of Columbia County, Florida. *GDG*

Parcel 2: Home, Parcel No.: R02306-003:

That part of Section 26, Township 3 South, Range 16 East as described as follows:

Lot 1 of Lake Jeffrey South, an unrecorded subdivision:

Commence at the Northwest corner of Section 26, and run South 73 deg. 14 min. 14 sec. East, 2248.26 feet for a point of beginning; thence continue South 73 deg. 14 min. 14 sec. East, 348.34 feet to its intersection with the occupied west line extension of that parcel described in Official Records Book 458, page 265 of the Public Records of Columbia County, Florida; thence South 03 deg. 44 min. 14 sec. East along said occupied line 992.97 feet to the Northerly right of way line of a 60.00 foot road; thence North 73 deg. 29 min. 52 sec. West along said right of way line 374.13 feet; thence North 02 deg. 22 min. 57 sec. West, 985.81 feet to the Point of Beginning. *GDG*

Together with a non-exclusive perpetual easement for ingress and egress over and upon the following described property:

A strip of land 60 feet wide lying 30 feet right and 30 feet left of the following described centerline:

Begin at the Northern terminal point of Harris Lake Drive per plat of Fairway View Unit 2-A, as recorded in Plat Book 4, Page 115 of the Public Records of Columbia County, Florida, said point being also on the arc of a curve concave to the Southwest having a radius of 320.00 feet and a total central angle of 82 deg. 36 min. 00 sec.; thence Northwesterly along the arc of said curve 144.92 feet to the point of reverse curve of a curve concave to the Northeast having a radius of 305.00 feet and a total central angle of 79 deg. 51 min. 04 sec.; thence Northwesterly along the arc of said curve 425.07 feet to the point of tangency of said curve, thence North 03 deg. 55 min. 49 sec. East, 150.00 feet to the point of curve of a curve concave to the East having a radius of 410.00 feet and a total central angle of 09 deg. 57 min. 00 sec.; thence Northerly along the arc of said curve 71.20 feet to the point of tangency of said curve; thence North 06 deg. 01 min. 11 sec. East, 98.20 feet to its intersection with the arc of a curve concave to the North having a radius of 530.00 feet and a total central angle of 47 deg. 59 min. 37

sec.; thence Easterly along the arc of said curve 132.15 feet to the point of tangency of said curve, thence North 81 deg. 43 min. 31 sec. East, 177.76 feet to the point of curve of a curve concave to the South having a radius of 460.00 feet and a total central angle of 24 deg. 52 min. 14 sec.; thence easterly along the arc of said curve 199.67 feet to the point of tangency of said curve; thence South 73 deg. 24 min. 13 sec. East, 257.41 feet; thence North 16 deg. 35 min. 47 sec. East, 290.07 feet to the point of beginning of said strip of land; thence North 22 deg. 03 min. 40 sec. East, 47.54 feet to the point of tangency of a curve concave to the Southeast having a radius of 62.00 feet and a total central angle of 97 deg. 42 min. 12 sec.; thence Northerly, Easterly and Southeasterly along the arc of said curve 105.73 feet to the point of tangency of said curve; thence South 60 deg. 14 min. 08 sec. East, 18.67 feet to the point of curve of a curve concave to the North having a radius of 625.00 feet and a total central angle of 12 deg. 54 min. 40 sec.; thence Southeasterly along the arc of said curve 140.84 feet to the point of tangency of said curve, thence South 73 deg. 08 min. 48 sec. East, 587.05 feet to the point of tangency of a curve concave to the Northwest having a radius of 100.00 feet and a total central angle of 103 deg. 47 min. 35 sec.; thence Northerly along the arc of said curve 181.15 feet to the point of tangency of said curve; thence North 03 deg. 03 min. 37 sec. East, 506.17 feet to the point of curve of a curve concave to the Southeast having a radius of 130.00 feet and a total central angle of 43 deg. 50 min. 24 sec.; thence Northeasterly along the arc of said curve 99.47 feet to the point of tangency of said curve; thence North 46 deg. 54 min. 01 sec. East, 295.93 feet; thence North 42 deg. 47 min. 49 sec. East, 335.82 feet to the point of curve of a curve concave to the Northwest having a radius of 320.00 feet and a total central angle of 32 deg. 08 min. 15 sec.; thence Northeasterly along the arc of said curve 179.49 feet to the point of tangency of said curve; thence North 10 deg. 39 min. 34 sec. East, 99.94 feet to the point of curve of a curve concave to the Southeast having a radius of 480.00 feet and a total central angle of 11 deg. 48 min. 00 sec.; thence Northerly along the arc of said curve 98.86 feet to the point of tangency of said curve; thence North 22 deg. 27 min. 34 sec. East, 90.46 feet to the point of curve of a curve concave to the Northwest having a radius of 620.00 feet and a total central angle of 26 deg. 34 min. 30 sec.; thence Northerly along the arc of said curve 287.57 feet to the point of tangency of said curve; thence North 04 deg. 06 min. 56 sec. West, 537.15 feet to the point of curve of a curve concave to the Southeast having a radius of 250.00 feet and a total central angle of 47 deg. 36 min. 15 sec.; thence Northerly along the arc of said curve 207.71 feet to the point of tangency of said curve; thence North 43 deg. 29 min. 19 sec. East, 825.97 feet to the Southwesterly right of way line of State Road No. 250 and the terminal point of said centerline. 

Also:

A part of the Northwest 1/4 of Section 26, Township 3 South, Range 16 East, more particularly described as follows: Commence at the Northwest corner of said Section 26 and run South 02 deg. 22 min. 57 sec. East, along the West line thereof 954.34 feet, thence run South 73 deg. 29 min. 52 sec. East, parallel with the North right of way of the S.C.L. Railroad and 60.00 feet therefrom as measured perpendicular thereto, 224.13 feet for a point of beginning; thence continue South 73 deg. 29 min. 52 sec. East, parallel with said right of way line a distance of 524.13 feet to a point of curve for a curve to the left, having a radius of 1146.91 feet, an included angle of 10 deg. 12 min. 50 sec.; thence Southeasterly along the arc of said curve for an arc distance of 204.45 feet to the end of said curve; thence South 88 deg. 42 min. 42 sec. East, 83.00 feet to a point of curve for a curve to the right; thence Southeasterly along the arc of said curve whose radius is 337.71 feet, through an included angle of 37 deg. 42 min. 10 sec., for an arc distance of 222.22 feet to a point of reverse curve; thence Southeasterly along the arc of a curve to the left having a radius of 389.54 feet, an included angle of 27 deg. 29 min. 20 sec. for an arc distance of 186.89 feet to the end of said curve; thence South 73 deg. 29 min. 52 sec. East, 1217.70 feet; thence South 03 deg. 44 min. 14 sec. East, 63.99 feet to the North right of way line of the said S.C.L. Railroad; thence North 73 deg. 29 min. 52 sec. West, along said railroad right of way, 1742.74 feet to the South line of the Northwest 1/4 of said Northwest 1/4, thence North 88 deg. 42 min. 44 sec. East, along said South line 130.92 feet; thence continue along said right of way line North 73 deg. 29 min. 52 sec. West, 790.38 feet; thence North 02 deg. 22 min. 57 sec. West, 63.41 feet to the point of beginning, Columbia County, Florida. 

Parcel 3: South Town Square, Parcel No. R07610-002:

Land lying and being in the Southwest 1/4, Section 5, Township 4 South, Range 17 East, Columbia County (Lake City), Florida, more fully described as follows:

Beginning at the Northeast corner of the NW 1/4 of the SW 1/4 of Section 5, Township 4 South, Range 17 East, Columbia County, Florida, said point being further described as lying in the Southern line of St. Margaret Road; thence North 89 deg. 56 min. 43 sec. East along the Southern line of St. Margaret Road, 181.45 feet to a point; thence South 6 deg. 24 min. 25 sec. West, 149.56 feet to a point, said point being the Northwest corner of the property of Columbia Arms, Inc.; thence South 6 deg. 57 min. 11 sec. West along the Western line of the Columbia Arms property, 685.70 feet to a point, said point lying in the Northern line of a 50 foot drainage easement previously granted to the City of Lake City, Florida;

thence North 84 deg. 10 min. 30 sec. West along the Northern line of said easement, 464.47 feet to a point in the Eastern line of U.S. Highway No. 41 (State Road No. 25); thence North 9 deg. 53 min. 30 sec. East along the Eastern line of said U.S. Highway No. 41, 794.24 feet to the South right-of-way line of St. Margaret Road ; thence North 89 deg. 56 min. 43 sec. East along the Southern right-of-way line of St. Margaret Road, 244.00 feet, more or less to the Point of Beginning.

LESS AND EXCEPT the property described in Official Records Book 777 at Page 2370 of the Public Records of Columbia County, Florida.

Parcel 4: South Town Square, Parcel No. R07610-005:

Commence at the Northeast corner of the NW 1/4 of the SW 1/4 of Section 5, Township 4 South, Range 17 East, said point being further described as lying in the Southern line of St. Margaret Road; run thence North 89 deg. 56 min. 43 sec. East along the Southern line of St. Margaret Road, 181.45 feet to the true point of beginning; thence North 89 deg. 56 min. 43 sec. East along the Southern line of St. Margaret Road 91.0 feet to a point; thence South 0 deg. 03 min. 17 sec. East, 161.9 feet to a point in the Northern line of the property of Columbia Arms, Inc.; thence North 83 deg. 01 min. 59 sec. West along the Northern line of the said Columbia Arms property, 108.65 feet to the Northwestern corner thereof; thence North 06 deg. 24 min. 25 sec. East, 149.56 feet to the Point of Beginning.

Parcel 5: Two-unit retail buildings, Parcel Nos: R12997-000 and R12997-001:

That tract, piece or parcel of land more particularly described as follows:

Begin at the NE corner of SW 1/4 of the NW 1/4 of Section 33, Township 3 South, Range 17 East and run thence South 8 deg. 3 min. West a distance of 49 feet for a Point of Beginning; thence run South 8 deg. 3 min. West a distance of 508 feet to the North line of St. Johns Street; thence Westerly along the North line of said St. Johns Street a distance of 244 feet to the East line of Chestnut Street; thence North 7 deg. 47 min. East along the East line of Chestnut Street a distance of 484 feet to the South line of Duval Street; thence North 86 deg. 16 min. East along the South line of said Duval Street, a distance of 249.9 feet to the Point of Beginning; except a tract of land in the Northwest corner thereof measuring 150 feet East and West on Duval Street and 150 feet North and South on Chestnut Street, all of the above lying and being in the SW 1/4 of the NW 1/4 of Section 33, Township 3 South, Range 17 East, Columbia County, Florida.

Parcel 6: Vacant, Parcel No.: R12998-000:

Situate in the City of Lake City, Florida, being a portion of the SW 1/4 of the NW 1/4 of Section 33, Township 3 South, Range 17 East, Columbia County, Florida, and being more particularly described as follows:

Beginning at a set straight-cut in concrete walk at the intersection of the Southerly right of way line of East Duval Street (U.S. Highway #90) (42 foot right of way) with the Easterly right of way line of Chestnut Street (33 foot right of way); running thence (1) along said right of way line of East Duval Street North 86 deg. 16 min. East 150 feet to a set concrete monument in a line of land now or formerly of Chestnut Street Plaza, Inc., thence (2) along said line of land of Chestnut Street Plaza, Inc., South 07 deg. 47 min. West 150 feet to a set iron in another line of land of Chestnut Street Plaza, Inc.; thence (3) along said other line of land of Chestnut Street Plaza, Inc. North 82 deg. 13 min. West 145.69 feet to a set concrete monument in the said right of way line of Chestnut Street; and thence (4) along said right of way line of Chestnut Street, North 07 deg. 10 min. East 120.06 feet to the Place of Beginning.

Less additional right of way for State Road 10 (US 90) per O.R. Book 772, Page 1800 of the Public Records of Columbia County, Florida.

Parcel 7: Vacant, Parcel No.: R13061-000:

Section 33, Township 3 South, Range 17 East: Commence at the intersection of the South line of Duval Street and the West line of Colburn Avenue, said Colburn Avenue being 30 feet in width, and run West along the South line of said Duval Street, a distance of 212.5 feet for a Point of Beginning; run South 7 deg. 48 min. West 527 feet to the North line of St. Johns Street; run North 88 deg. 35 min. West along the North line of said St. Johns Street, 211 feet; run North 7 deg. 40 min. East 508 feet to the South line of Duval Street; run North 86 deg. 16 min. East along the South line of said Duval Street, 212.5 feet to Point of Beginning; said lands being bounded on the West by land formerly owned by C.B. Messer and known as Duval Tourist Camp, all of the above described lands lying and being wholly within the SE 1/4 of NW 1/4 of Section 33, Township 3 South, Range 17 East, Columbia County, Florida.

Less additional right of way for State Road 10 (US 90) per O.R. Book 772, Page 1800 of the Public Records of Columbia County, Florida.

Parcel 8: Vacant, Parcel No.: R13079-000:

Section 33, Township 3 South, Range 17 East: Commence at the intersection of the West line of Colburn Street and the North line of St. Johns Street and run North 88 deg. 52 min. West along the North line of said St. Johns Street, 95.85 feet for a Point of Beginning; run North 88 deg. 52 min. West 100 feet; run North 7 deg. 48 min. East, along the East line of Waldron Street, 200 feet; run South 88 deg. 52 min. East 100 feet; run South 7 deg. 48 min. West 200 feet to Point of Beginning, said lands being wholly within the SE 1/4 of the NW 1/4 of Section 33, Township 3 South, Range 17 East, Columbia County, Florida.

Parcel 9: Vacant, Parcel No. R13070-000:

Commence at the South line of Duval Street at its intersection with the West line of Colburn Avenue and run thence South 86 deg. 16 min. West along the South line of Duval Street, a distance of 127.3 feet for a Point of Beginning; and thence run South 86 deg. 16 min. West along the South line of Duval Street, a distance of 70 feet; thence run South 07 deg. 48 min. West along the East line of Waldron Street a distance of 170 feet; thence run North 86 deg. 16 min. East 70 feet; thence run North 07 deg. 48 min. East 170 feet to the South line of Duval Street and the Point of Beginning. All lying and being in Section 33, Township 3 South, Range 17 East, Columbia County, Florida.

Less additional right of way for State Road 10 (US 90) per O.R. Book 772, Page 1798, of the Public Records of Columbia County, Florida.

Also:

A parcel of land lying in the Southeast 1/4 of the Northwest 1/4 of Section 33, Township 3 South, Range 17 East, Lake City, Florida, being more particularly described as follows:

Commence at the intersection of the South right of way line of Duval Street (U.S. Highway No. 90) and the East right of way line of Waldron Street and run South 8 deg. 41 min. 21 sec. West along said East right of way line of Waldron Street, 170.49 feet to the Point of Beginning; thence run North 86 deg. 48 min. 31 sec. East, a distance of 70.97 feet; thence run South 8 deg. 48 min. 58 sec. West, a distance of 44.11 feet; thence run North 88 deg. 00 min. 52 sec. West, a distance of 69.83 feet to the East right of way line of Waldron Street; thence run North 8 deg. 41 min. 21 sec. West along said East right of way line 37.65 feet to the Point of Beginning.

Parcel 10: Vacant, Parcel No. R13092-000:

Section 33, Township 3 South, Range 17 East: Commence at the South line of Duval Street at its intersection with the East line of Waldron Street and run South along the East line of Waldron Street for a Point of Beginning, a distance of 207.83 feet, thence South along the said East line of Waldron Street, a distance of 120 feet; thence East along a line parallel with the North line of East St. Johns Street, a distance of 100 feet; thence North along a line parallel with the East line of Waldron Street, a distance of 120 feet; thence West along a line parallel with the North line of East St. Johns Street, a distance of 100 feet to the Point of Beginning, said lands lying and being wholly within the SE 1/4 of NW 1/4 of Section 33, Columbia County, Florida.

Less and Except:

A parcel of land lying in the Southeast 1/4 of the Northwest 1/4 of Section 33, Township 3 South, Range 17 East, Lake City, Florida, being more particularly described as follows:

Commence at the intersection of the South right of way line of Duval Street (U.S. Highway No. 90) and the East right of way line of Waldron Street and run South 8 deg. 41 min. 21 sec. West along said East right of way line of Waldron Street 208.14 feet; thence run South 88 deg. 00 min. 52 sec. East, a distance of 69.83 feet to the Point of Beginning; thence continue South 88 deg. 00 min. 52 sec. East, a distance of 30.00 feet; thence run South 8 deg. 36 min. 19 sec. West, a distance of 137.72 feet; thence run North 81 deg. 53 min. 00 sec. West, a distance of 30.30 feet; thence run North 8 deg. 48 min. 58 sec. East, a distance of 134.52 feet to the Point of Beginning.

Grantor herein reserves a life estate in and to Parcel 2: Home, Parcel No.: R02306-003 described above.

Grantor and Harvey L. Boris were continuously and uninterruptedly married from the date they acquired said property until the date of death of Harvey L. Boris on February 7, 2005.

N.B. This deed has been prepared at Grantor's request without examination or legal opinion of title.

In the event Patricia Faye Boris cannot continue to serve as Trustee, the successor trustee shall be Michael Harvey Boris and Mark David Boris, jointly. If one of them should be unable or unwilling to act, the next successor Trustee shall be Tina Marie Matsubara. If two of them should be unable or unwilling to act, the remaining Trustee shall act as sole Trustee.

The Trustee and all successor Trustees are hereby granted the power to protect, conserve, and to sell, or to lease, or to encumber, or otherwise to manage and dispose of the real property described in this deed.

Any person dealing with the Trustee shall deal with said Trustee in the order as set forth above. However, no person shall deal with a successor Trustee until one or more of the following have been received by said person or placed of record in the aforementioned county:

- A. The written resignation of the prior Trustee sworn to and acknowledge before a notary public.
- B. A certified death certificate of the prior Trustee.
- C. The order of a court of competent jurisdiction adjudicating the prior Trustee incapacitated, or removing said Trustee for any reason.
- D. The written certificates of two physicians currently practicing medicine that the Trustee is physically or mentally incapable of handling the duties of Trustee.
- E. The written removal of a successor Trustee and/or the appointment of an additional successor Trustee by the Grantor sworn to and acknowledged before a notary public; this right being reserved to the Grantor.

"Grantor" and "Grantee" are used for singular or plural, as context requires.

AND SAID GRANTOR does hereby fully warrant the title to said land, and will defend the same against the lawful claims of all persons whomsoever.

In Witness Whereof, Grantor has hereunto set Grantor's hand and seal the day and year first above written.

Witnesses to signature(s) of Patricia Faye Boris

Amy L. Kenner



Patricia Faye Boris



Gary D. Grunder

STATE OF FLORIDA
COUNTY OF ALACHUA

The foregoing instrument was acknowledged before me MAY 16, 2007 by Patricia Faye Boris who

- () is/are personally known to me.
- () produced a current Florida driver's license as identification.
- () produced _____ identification.

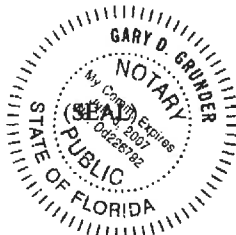
Signature of Notary
My Commission Expires:
7951





GROWTH MANAGEMENT DEPARTMENT
 205 North Marion Ave. Lake City, FL 32055
 Phone: 386-719-5750
 E-mail: growthmanagement@lcfla.com

AGENT AUTHORIZATION FORM

I, BORIS, PATRICIA FAYE REVOCABLE LIVING TRUST (owner name), owner of property parcel
 number 33-35-17-13061-000 33-35-17-13070-000
33-35-17-13079-000 33-35-17-13092-000 (parcel number), do certify that

the below referenced person(s) listed on this form is/are contracted/hired by me, the owner, or, is an officer of the corporation; or, partner as defined in Florida Statutes Chapter 468, and the said person(s) is/are authorized to sign, speak and represent me as the owner in all matters relating to this parcel.

Printed Name of Person Authorized	Signature of Authorized Person
1. <u>TERRY C. JINDEATH, III</u>	1.
2. <u>Paul Marcinko</u>	2.
3.	3.
4.	4.
5.	5.

I, the owner, realize that I am responsible for all agreements my duly authorized agent agrees with, and I am fully responsible for compliance with all Florida Statutes, City Codes, and Land Development Regulations pertaining to this parcel.

If at any time the person(s) you have authorized is/are no longer agents, employee(s), or officer(s), you must notify this department in writing of the changes and submit a new letter of authorization form, which will supersede all previous lists. Failure to do so may allow unauthorized persons to use your name and/or license number to obtain permits.

Patricia Faye Boris Date 4/12/23
 Owner Signature (Notarized)

NOTARY INFORMATION:
 STATE OF: FLORIDA COUNTY OF: COLUMBIA

The above person, whose name is PATRICIA F. BORIS
 personally appeared before me and is known by me or has produced identification
 (type of I.D.) _____ on this 12 day of APRIL, 2023.

Brenda J. Douglass
 NOTARY'S SIGNATURE

(Seal/Stamp)

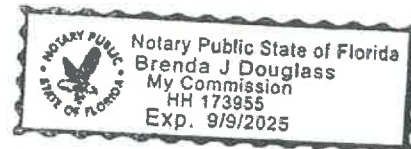

NOTARIZED AUTHORIZATION OF OWNER

I/We, Mark Boris, As Trustee of Patricia Faye Boris Living Trust as the sole or joint fee simple title holder(s) of the property described as parcels 33-3S-17-13061-000, 33-3S-17-13079-000, 33-3S-17-13070-000, 33-3S-17-13092-000 in the City of Lake City, County of Columbia, State of Florida, authorize HSC Lake City, LLC (Hix Snedeker Companies) and JADE Consulting, LLC and/or their consultants to act as our agent to seek City, County or state permitting, subdivision, Site Plan/Development, Variance, DOT & DEP approvals, and/or all regulatory approvals in connection therewith, on the above referenced property.

Company: Mark
Boris

Mark Boris

By:

As Its: Owner/ Seller

Address: Po
box 2095
Lake City, Fl
32056

Phone: 3863970728 Fax: _____

Email: mark.boris@frenveyinc.com

STATE OF FL.

COUNTY OF Columbia

The forgoing instrument was acknowledged before me this 27 day of SEPTEMBER 2023 by MARK BORIS as its Owner/Seller, who is personally known to me or who has produced _____ (type of ID) as identification and who did not take an oath.

Brenda Douglass
NOTARY PUBLIC - STATE OF FLORIDA

BRENDA DOUGLASS
NAME OF NOTARY - TYPED OR PRINTED

COMMISSION NO: _____

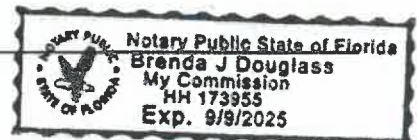

+ 7+

Account Number	Tax Type	Tax Year
R13061-000	REAL ESTATE	2022

Mailing Address BORIS PATRICIA FAYE REVOCABLE LIVING TRUST PO BOX 2095 LAKE CITY FL 32056	Property Address GEO Number 333S17-13061-000
--	--

Exempt Amount	Taxable Value
See Below	See Below

Exemption Detail	Millage Code	Escrow Code
NO EXEMPTIONS	001	
Legal Description (click for full description)		
33-3S-17 1000/10002.27 Acres E DIV BEG INTERS S DUVAL ST & W R/W WALDRON ST, RUN SE 18.86 FT, SW ALONG R/W 512 FT TO N R/W ST JOHN ST, W ALONG R/W 187.32 FT, N 506.17 FT TO S R/W DUVAL ST, E ALONG R/W 183.97 FT TO POB. ORB 772-1800 1801, DC ORB 1060-31, LOA IN ORB 1075-2790, WD 1120-405		

Ad Valorem Taxes					
Taxing Authority	Rate	Assessed Value	Exemption Amount	Taxable Value	Taxes Levied
CITY OF LAKE CITY	4.9000	151,545	0	\$151,545	\$742.57
BOARD OF COUNTY COMMISSIONERS	7.8150	151,545	0	\$151,545	\$1,184.32
COLUMBIA COUNTY SCHOOL BOARD					
DISCRETIONARY	0.7480	151,545	0	\$151,545	\$113.35
LOCAL	3.2990	151,545	0	\$151,545	\$499.95
CAPITAL OUTLAY	1.5000	151,545	0	\$151,545	\$227.32
SUWANNEE RIVER WATER MGT DIST	0.3368	151,545	0	\$151,545	\$51.04
LAKE SHORE HOSPITAL AUTHORITY	0.0001	151,545	0	\$151,545	\$0.02
Total Millage		18.5989	Total Taxes		\$2,818.57

Non-Ad Valorem Assessments		
Code	Levying Authority	Amount
XLCF	CITY FIRE ASSESSMENT	\$50.40
Total Assessments		\$50.40

Taxes & Assessments \$2,868.97

If Paid By	Amount Due
	\$0.00

Date Paid	Transaction	Receipt	Item	Amount Paid
11/30/2022	PAYMENT	1800507.0004	2022	\$2,754.21

Account Number	Tax Type	Tax Year
R13079-000	REAL ESTATE	2022

Mailing Address BORIS PATRICIA FAYE REVOCABLE LIVING TRUST PO BOX 2095 LAKE CITY FL 32056	Property Address GEO Number 333S17-13079-000
--	--

Exempt Amount	Taxable Value
See Below	See Below

Exemption Detail NO EXEMPTIONS	Millage Code 001	Escrow Code
Legal Description (click for full description) 33-3S-17 0000/0000.45 Acres E DIV: COMM INTERS W R/W COLBURN AVE & N R/W ST JOHNS ST, RUN W 95.85 FT FOR POB, CONT W 100 FT, N 200 FT, E 100 FT, S 200 FT TO POB. (PART OF SE1/4 OF NW1/4) ORB 508-711, DC ORB 1060-31, LOA IN ORB 1075-2790, WD 1120-405		

Ad Valorem Taxes

Taxing Authority	Rate	Assessed Value	Exemption Amount	Taxable Value	Taxes Levied
CITY OF LAKE CITY	4.9000	11,422	0	\$11,422	\$55.97
BOARD OF COUNTY COMMISSIONERS	7.8150	11,422	0	\$11,422	\$89.26
COLUMBIA COUNTY SCHOOL BOARD					
DISCRETIONARY	0.7480	13,153	0	\$13,153	\$9.84
LOCAL	3.2990	13,153	0	\$13,153	\$43.39
CAPITAL OUTLAY	1.5000	13,153	0	\$13,153	\$19.73
SUWANNEE RIVER WATER MGT DIST	0.3368	11,422	0	\$11,422	\$3.85
LAKE SHORE HOSPITAL AUTHORITY	0.0001	11,422	0	\$11,422	\$0.00

Total Millage	18.5989	Total Taxes	\$222.04
----------------------	---------	--------------------	----------

Non-Ad Valorem Assessments

Code	Levying Authority	Amount
XLCF	CITY FIRE ASSESSMENT	\$50.40
Total Assessments		\$50.40

Taxes & Assessments \$272.44

If Paid By	Amount Due
	\$0.00

Date Paid	Transaction	Receipt	Item	Amount Paid
12/8/2022	PAYMENT	1502290.0001	2022	\$261.54

Account Number	Tax Type	Tax Year
R13070-000	REAL ESTATE	2022

Mailing Address BORIS PATRICIA FAYE REVOCABLE LIVING TRUST P O BOX 2095 LAKE CITY FL 32056	Property Address GEO Number 333S17-13070-000
---	--

Exempt Amount	Taxable Value
See Below	See Below

Exemption Detail	Millage Code	Escrow Code
NO EXEMPTIONS	001	
Legal Description (click for full description)		
33-3S-17 1000/1000.33 Acres E DIV: BEG INTERS OF S R/W OF DUVAL ST & E R/W OF WALDRON ST, RUN E ALONG R/W 36.54 FT, S 169.44 FT, W 71 FT TO E R/W WALDRON ST, N ALONG R/W 154.98 FT, NE 23.40 FT TO POB, ALSO COMM INTERS S R/W DUVAL ST & E R/W WALDRON ST, RUN S 8 DEG See Tax Roll For Extra Legal		

Ad Valorem Taxes

Taxing Authority	Rate	Assessed Value	Exemption Amount	Taxable Value	Taxes Levied
CITY OF LAKE CITY	4.9000	36,146	0	\$36,146	\$177.12
BOARD OF COUNTY COMMISSIONERS	7.8150	36,146	0	\$36,146	\$282.48
COLUMBIA COUNTY SCHOOL BOARD					
DISCRETIONARY	0.7480	36,146	0	\$36,146	\$27.04
LOCAL	3.2990	36,146	0	\$36,146	\$119.25
CAPITAL OUTLAY	1.5000	36,146	0	\$36,146	\$54.22
SUWANNEE RIVER WATER MGT DIST	0.3368	36,146	0	\$36,146	\$12.17
LAKE SHORE HOSPITAL AUTHORITY	0.0001	36,146	0	\$36,146	\$0.00
Total Millage		18.5989	Total Taxes		\$672.28

Non-Ad Valorem Assessments

Code	Levying Authority	Amount
XLCF	CITY FIRE ASSESSMENT	\$50.40
Total Assessments		\$50.40
Taxes & Assessments		\$722.68
If Paid By		Amount Due
		\$0.00

Date Paid	Transaction	Receipt	Item	Amount Paid
11/30/2022	PAYMENT	1800507.0001	2022	\$693.77

Account Number	Tax Type	Tax Year
R13092-000	REAL ESTATE	2022

Mailing Address BORIS PATRICIA FAYE REVOCABLE LIVING TRUST P O BOX 2095 LAKE CITY FL 32056	Property Address GEO Number 333S17-13092-000
---	--

Exempt Amount	Taxable Value
See Below	See Below

Exemption Detail	Millage Code	Escrow Code
NO EXEMPTIONS	001	
Legal Description (click for full description)		
33-3S-17 0000/0000.19 Acres E DIV: BEG 207.83 FT S OF INTERS S R/W DUVAL ST & E R/W WALDRON ST, RUN S 120 FT, E 100 FT, N 120 FT, W 100 FT TO POB, EX THE E 30 FT DESC IN ORB 933-2377, DC ORB 1060-31, LOA IN ORB 1075-2790, WD 1120-405		

Ad Valorem Taxes

Taxing Authority	Rate	Assessed Value	Exemption Amount	Taxable Value	Taxes Levied
CITY OF LAKE CITY	4.9000	5,333	0	\$5,333	\$26.13
BOARD OF COUNTY COMMISSIONERS	7.8150	5,333	0	\$5,333	\$41.68
COLUMBIA COUNTY SCHOOL BOARD					
DISCRETIONARY	0.7480	6,141	0	\$6,141	\$4.59
LOCAL	3.2990	6,141	0	\$6,141	\$20.26
CAPITAL OUTLAY	1.5000	6,141	0	\$6,141	\$9.21
SUWANNEE RIVER WATER MGT DIST	0.3368	5,333	0	\$5,333	\$1.80
LAKE SHORE HOSPITAL AUTHORITY	0.0001	5,333	0	\$5,333	\$0.00

Total Millage	18.5989	Total Taxes	\$103.67
----------------------	---------	--------------------	----------

Non-Ad Valorem Assessments

Code	Levying Authority	Amount
XLCF	CITY FIRE ASSESSMENT	\$50.40
Total Assessments		\$50.40

Taxes & Assessments \$154.07

If Paid By	Amount Due
	\$0.00

Date Paid	Transaction	Receipt	Item	Amount Paid
11/30/2022	PAYMENT	1800507.0002	2022	\$147.91