

GENERAL DEVELOPMENT NOTES

1. **PROPOSED NAME OF PROJECT:** RIB CRIB BBQ
2. **PROJECT DESCRIPTION:** RESTAURANT
3. **OWNER:** PARKER NEELY
4. **DEVELOPER:** CENTURY EQUITY PARTNERS; 2682 NW NOEGEL ROAD, LAKE CITY, FL 32055
5. **CIVIL ENGINEER:** JBROWN PROFESSIONAL GROUP INC.; CONTACT: CHRIS POTTS, P.E. (352) 375-8999, E-MAIL: CHRIS.POTTS@JBPRO.COM
6. **SURVEYOR:** JBROWN PROFESSIONAL GROUP INC.; CONTACT: TROY WRIGHT, PSM (352) 375-8999
7. **VICINITY MAP:** SEE MAP THIS SHEET
8. **TAX PARCEL NO'S.:** 35-3S-16-02524-008
9. **PARCEL AREA:** 1.06 ACRES IN SIZE
10. **PROJECT AREA:** 1.06 ACRES
11. **SECTION:** 3S
12. **TOWNSHIP:** 3S
13. **RANGE:** 16
14. **FUTURE LAND USE:** COMMERCIAL HIGHWAY INTERCHANGE (CHI)
15. **ZONING:** COMMERCIAL HIGHWAY INTERCHANGE (CHI)
16. **FLOODPLAIN:** THIS PROJECT IS NOT LOCATED IN A FEDERAL FLOOD ZONE.
17. **DEVELOPMENT DATA:**
 - A. TOTAL SITE AREA: 46,174 SF
 - B. BUILDING AREA: 3,428 SF
 - C. PAVEMENT & SIDEWALK AREA: 27,405 SF
 - D. TOTAL IMPERVIOUS AREA: 30873 SF
 - E. OPEN AREA: 15331 SF
18. **PARKING REQUIREMENTS:**
 - A. 1 SPACE/EA 3 SEATS OF SEATING AREA
 - B. PROPOSED SEATING: 106 SEATS
 - C. PARKING REQUIRED: 36 SPACES
 - D. PARKING PROVIDED: 42 SPACES
19. **REQUIRED SETBACKS:**
 - A. PER CHI ZONING CATEGORY, THE MINIMUM YARD REQUIREMENTS PER LAKE CITY LDR'S SECTION 4.15.7 ARE AS FOLLOWS:
 1. FRONT YARD = 30 FT
 2. SIDE YARD = 30 FT
 3. REAR YARD = 30 FT
 - B. ALL BUILDINGS ARE SETBACK GREATER THAN 30 FT FROM FRONT, SIDE, AND REAR PROPERTY LINES
 - C. FRONT YARD SHALL INCLUDE MINIMUM 15 FT LANDSCAPED AREA.

CONSTRUCTION PLANS OF GATEWAY CROSSING LOT 8 RIBCRIB BBQ FOR HIGH COTTON EQUITIES, LLC

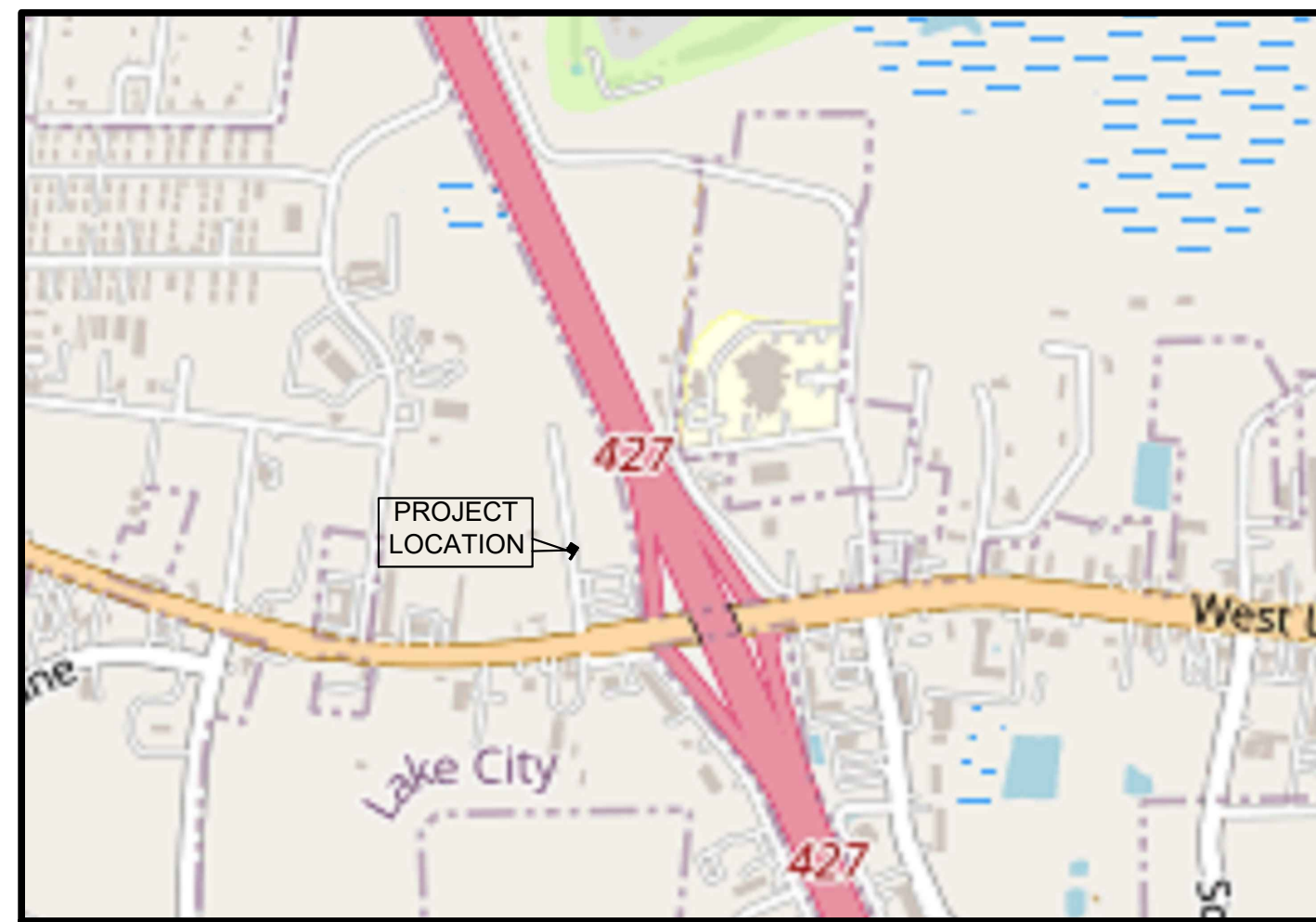

LOCATION MAP

N.T.S.

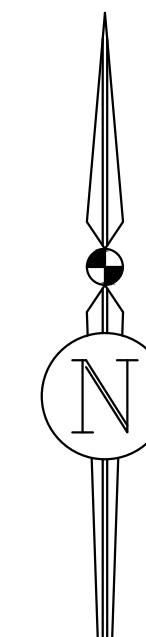

GATEWAY CROSSING LOT 8 RIB CRIB RESTAURANT	
SHEET INDEX	
SHEET NO.	TITLE
C0.0	COVER SHEET
C0.1	LEGEND, ABBREVIATIONS, AND NOTES
C1.0	DEMOLITION PLAN
C1.1	EROSION CONTROL PLAN
C2.0	DIMENSION PLAN
C3.0	PAVING GRADING & DRAINAGE PLAN
C4.0	UTILITY PLAN
C5.0	DETAILS AND NOTES
SI	ALTA/NSPS LAND SURVEY

REVISIONS				
NO.	DATE	DESCRIPTION	DRWN	APPR

ENGINEER OF RECORD: **CHRISTOPHER A. POTTS, P.E.**
FLORIDA LICENSE NO. 73842

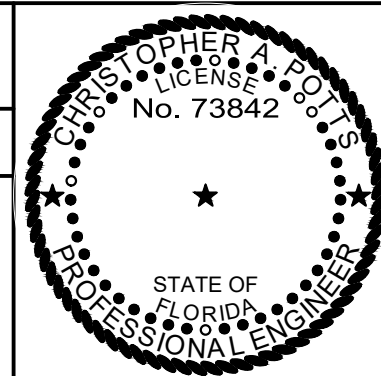

JBPro

CIVIL ENGINEERING | LAND PLANNING
SURVEYING | CONSTRUCTION SERVICES

3530 NW 43rd Street | Gainesville, Florida 32606
4420 US-1 S, Suite 1 | St. Augustine, Florida 32086
Gainesville: (352) 375-8999 | St. Augustine: (904) 789-8999
Toll Free: (844) Go-JBPro | E-mail: contact@jbpro.com

SHEET TITLE: <h2 style="text-align: center;">COVER SHEET</h2>	DATE: JUNE 2022 PROJECT NO.: 366-22-03 SHEET NO.: C0.0
CLIENT: HIGH COTTON EQUITIES, LLC	PROJECT: RIB CRIB RESTAURANT LAKE CITY, FLORIDA

GENERAL CONSTRUCTION NOTES

- 1. CONTRACTOR SHALL BE RESPONSIBLE FOR LOCATING ALL EXISTING UTILITIES WITHIN THE WORK LIMITS OF ALL IMPROVEMENTS. THE CONTRACTOR IS ALSO RESPONSIBLE FOR PROTECTING ALL EXISTING UTILITIES DURING CONSTRUCTION. IN THE EVENT THAT A UTILITY CONFLICT OCCURS, CONTRACTOR SHALL NOTIFY THE ENGINEER AND UTILITY PROVIDER TO COORDINATE REMEDIAL ACTION.
2. WHERE SUBSOIL EXCAVATION IS REQUIRED, THE LIMITS OF EXCAVATION SHALL BE IN ACCORDANCE WITH THE RECOMMENDATIONS OF THE GEOTECHNICAL REPORT. EXACT LOCATIONS OF SUBSOIL EXCAVATION SHALL BE AS DIRECTED BY THE CITY OF LAKE CITY OR THE GEOTECHNICAL ENGINEER.
3. CONTRACTOR SHALL DISPOSE OF SUBSOIL EXCAVATED MATERIALS (UNSUITABLE FOR FILL) OFF SITE TO A PERMITTED LOCATION OR PER AN APPROVED DISPOSAL PLAN AND LOCATION SITE.
4. CONTRACTOR IS RESPONSIBLE FOR DISPOSING OF ALL FOREIGN DEBRIS AND MATERIAL OFFSITE. DISPOSAL METHODS AND LOCATION SHALL BE IN ACCORDANCE WITH ALL APPLICABLE LOCAL, STATE, AND FEDERAL REGULATIONS AND REQUIREMENTS.
5. THE CONTRACTOR SHALL FURNISH/INSTALL ALL STREET SIGNS AND SHALL BE RESPONSIBLE FOR THE INSTALLATION OF ALL REQUIRED STRIPING, STOP BARS, ETC.
6. ALL PAVEMENT CUT/REPAIR WILL BE MADE THE FULL ROAD WIDTH AT LEAST 6 FT WIDE AND REQUIRES APPROVAL FOR CUT AND INSPECTION OF THE REPAIR BY THE CITY OF LIVE OAK.
7. DRIVEWAYS SHALL BE CONFIGURED TO ENSURE NO PORTION OF CURB INLET FALLS WITHIN DRIVEWAY AND/OR DRIVEWAY TAPER.
8. DRIVEWAYS SHALL BE DESIGNED IN ACCORDANCE WITH THE MOST RECENT FDOT INDEX AND CITY STANDARDS. DRIVEWAYS WILL MEET SETBACK REQUIREMENTS FROM INTERSECTIONS (SOFT) AND UTILITY INFRASTRUCTURE (5FT MIN.). DRIVEWAYS WITH SIDEWALK CROSSING SHALL MEET CURRENT ADA STANDARDS FOR THE LENGTH OF THE SIDEWALK CROSSING.
9. CONCRETE SIDEWALK CROSSING SHALL BE A MINIMUM OF 4 INCHES THICK AND HAVE A 3,000 PSI COMPRESSIVE STRENGTH.
10. ALL PROPOSED SIDEWALK SEGMENTS NOT ADJACENT TO LOT DRIVEWAYS WILL BE CONSTRUCTED PRIOR TO CITY OF LIVE OAK ACCEPTANCE OF SITE IMPROVEMENTS OR BONDED IN-LIEU OF CONSTRUCTION IN A FORM ACCEPTABLE TO THE CITY OF LIVE OAK.
11. EXISTING TOPOGRAPHY INFORMATION DEPICTED IS BASED ON THE PROJECT TOPOGRAPHIC SURVEY CONDUCTED BY JBPRO ON 12/09/2021. THE CONTRACTOR SHALL VERIFY ALL EXISTING ELEVATION GRADES AND NOTIFY THE ENGINEER OF ANY DISCREPANCIES THAT WILL AFFECT FINISH GRADE DESIGN FOR PROPER RUNOFF CONDITIONS PRIOR TO CONSTRUCTION. JBPRO WILL ASSIST THE CONTRACTOR IN REVISING ANY GRADING DISCREPANCIES PRIOR TO CONSTRUCTION TO ASSURE PROPER GRADING AND RUNOFF CONDITIONS RESULT UPON COMPLETION OF CONSTRUCTION.
12. ALL STRUCTURES SHALL ADHERE TO THE 2020 FLORIDA BUILDING CODE(S), THE 2020 NATIONAL ELECTRIC CODE AND THE 2020 FLORIDA FIRE PREVENTION CODE, AS AMENDED.

NPDES EROSION AND SEDIMENTATION CONTROL PERMITTING NOTES

- 1. THE CONTRACTOR IS REQUIRED TO FILE THE FLORIDA DEPT. OF ENVIRONMENTAL PROTECTION (FDEP) NOTICE OF INTENT (NOI) TO USE GENERIC PERMIT FOR STORMWATER DISCHARGE FROM LARGE AND SMALL CONSTRUCTION ACTIVITIES (CGP) (RULE 62-621.300(4), F.A.C.). CONSTRUCTION ACTIVITY SHALL NOT COMMENCE PRIOR TO OBTAINING AN ACKNOWLEDGEMENT LETTER FROM FDEP VERIFYING THE NOI IS COMPLETE, THE PROJECT IS COVERED BY THE GENERIC PERMIT, AND THE PROJECT IDENTIFICATION NO. IS ESTABLISHED. CONTRACTOR SHALL PROVIDE THE EOR AND PROPERTY OWNER WITH A COPY OF THE FDEP ACKNOWLEDGEMENT LETTER VERIFYING COVERAGE.
2. THE CONTRACTOR SHALL ABIDE BY THE REQUIREMENTS OF THE STORMWATER POLLUTION PREVENTION PLAN (SWPPP) AND CSP AT ALL TIMES THROUGHOUT CONSTRUCTION, AND UTILIZE ALL APPROPRIATE BEST MANAGEMENT PRACTICES (BMP'S) AS REQUIRED TO PREVENT EROSION AND SEDIMENTATION DISCHARGE OFFSITE DURING CONSTRUCTION.
3. SEDIMENTATION AND EROSION CONTROL BMP'S SHALL BE IN ACCORDANCE WITH THE STATE OF FLORIDA EROSION AND SEDIMENTATION CONTROL DESIGNER AND REVIEWER MANUAL, DATED JULY 2013, OR LATEST UPDATE. THE CONTRACTOR IS RESPONSIBLE TO UTILIZE ALL BMP'S, AS NECESSARY THROUGHOUT CONSTRUCTION, AND MAY UTILIZE MULTIPLE BMP'S OR OTHER MEANS AND METHODS DEEMED APPROPRIATE TO CONTROL EROSION AND SEDIMENTATION DISCHARGE.
4. THE CONTRACTOR SHALL UTILIZE A STATE OF FLORIDA CERTIFIED EROSION & SEDIMENTATION CONTROL (ESC) INSPECTOR DURING CONSTRUCTION TO ABIDE BY THE TERMS OF THE NOI PERMIT COVERAGE. AT A MINIMUM THE CERTIFIED INSPECTOR SHALL INSPECT ALL DISCHARGE POINTS, DISTURBED AREAS, MATERIAL STORAGE AREAS, STRUCTURAL CONTROLS AND CONSTRUCTION ENTRANCES/EXITS AT LEAST ONCE EVERY SEVEN (7) DAYS AND AFTER EVERY 1/2 INCH OR GREATER STORM EVENT. MAJOR OBSERVATIONS AND INCIDENTS OF NON-COMPLIANCE SHOULD BE RECORDED IN THE INSPECTION REPORT, AS WELL AS CORRECTIVE ACTIONS AND MAINTENANCE. UNLESS ADVISED OTHERWISE, MAINTENANCE MUST OCCUR WITHIN SEVEN (7) CALENDAR DAYS OF THE INSPECTION. THESE INSPECTIONS MUST BE DOCUMENTED AND SIGNED BY A QUALIFIED INSPECTOR AS DEFINED BY THE COP. THE REPORT SHALL CONTAIN A CERTIFICATION THAT THE FACILITY IS IN COMPLIANCE WITH THE SWPPP AND THE COP WHEN THE REPORTS DO NOT IDENTIFY ANY INCIDENTS OF NON-COMPLIANCE.
5. UPON SATISFACTORY COMPLETION OF THE PROJECT CONSTRUCTION AND SITE STABILIZATION, THE CONTRACTOR SHALL FILE THE NPDES STORMWATER NOTICE OF TERMINATION (NOT) (RULE 62-621.300(6), F.A.C.) WITH FDEP. THE PERMIT COVERAGE IS DEEMED COMPLETE WHEN ALL SOIL DISTURBING CONSTRUCTION ACTIVITIES ARE COMPLETE AND STABILIZATION OF ALL DISTURBED OPEN AREAS HAVE REACHED AT LEAST 70% VEGETATIVE COVER OR OTHER PERMANENT STABILIZATION IS IN PLACE. A COPY OF THE NOT SHALL BE PROVIDED TO THE EOR AND PROPERTY OWNER.

GEOTECHNICAL TESTING GENERAL NOTE

- 1. THE CONTRACTOR SHALL BE RESPONSIBLE FOR PROVIDING GEOTECHNICAL TESTING FOR EACH SPECIFIED DESIGN COURSE, SUBGRADE, BASE COURSE, AND PAVEMENT. TESTING REQUIREMENTS SHALL BE PERFORMED IN ACCORDANCE WITH THE CITY OF LIVE OAK PUBLIC SERVICES CONSTRUCTION AND INSPECTION STANDARDS AND FDOT CONSTRUCTION AND INSPECTION STANDARDS. TESTING RESULTS SHALL BE PROVIDED TO THE OWNER AND THE ENGINEER FOR REVIEW AND APPROVAL OF CONFORMANCE TO DESIGN SPECIFICATIONS PRIOR TO CONSTRUCTION OF THE SUBSEQUENT COURSE.
2. TESTING REPORTS WITH GEOTECHNICAL TESTING RESULTS SHALL DENOTE THE TESTING LOCATIONS.

REQUIRED SUBMITTALS

- 1. PRIOR TO CONSTRUCTION INSTALLATION OF SPECIFIC WORK SCOPE ITEMS THE CONTRACTOR SHALL SUBMIT SHOP DRAWINGS AND SUBMITTAL INFORMATION TO THE EOR FOR REVIEW AND APPROVAL. THESE SUBMITTALS SHALL INCLUDE SOURCE PROVIDER, MANUFACTURER LITERATURE, CUT SHEETS, DIMENSIONED DRAWINGS, FABRICATION DRAWINGS, SKETCHES, DETAILS AND ANY OTHER INFORMATION NECESSARY FOR THE EOR TO REVIEW AND APPROVE AS TO COMPLIANCE WITH THE DESIGN DRAWINGS AND SPECIFICATIONS.
2. MATERIALS SHALL NOT BE DELIVERED ONSITE OR INSTALLED UNTIL SUBMITTAL APPROVAL IS PROVIDED BY THE EOR OR EOR'S REPRESENTATIVE.
3. CONTRACTOR IS RESPONSIBLE FOR ANY COST INCURRED TO REVISE ANY WORK COMPLETED PRIOR TO SUBMITTAL APPROVAL. THE OWNER OR EOR ARE NOT RESPONSIBLE FOR COSTS INCURRED IF ANY MATERIALS ARE PURCHASED, DELIVERED OR INSTALLED PRIOR TO SUBMITTAL REVIEW AND APPROVAL.
4. THE CONTRACTOR SHALL PROVIDE A LIST OF SUB-CONTRACTORS THAT WILL BE PERFORMING ANY PHASES OF WORK ON THE PROJECT. THE LIST SHALL INCLUDE NAME OF COMPANY, ADDRESS, PHONE NUMBERS, AND EMAIL ADDRESSES OF INDIVIDUALS RESPONSIBLE FOR THE SUB-CONSULTANT WORK EFFORT AND THE CONTACT INFORMATION FOR THE INDIVIDUALS IN RESPONSIBLE CHARGE OF PERFORMING THE WORK IN THE FIELD.

WORK WITHIN THE CITY RIGHT-OF-WAY

- 1. THE METHOD AND MANNER OF PERFORMING THE WORK AND THE QUALITIES OF MATERIAL FOR CONSTRUCTION WITHIN THE RIGHT-OF-WAY SHALL CONFORM TO THE REQUIREMENTS SPECIFIED BY CITY OF LAKE CITY FOR WORK WITHIN THEIR RESPECTIVE RIGHT-OF-WAYS.
2. TRAFFIC CONTROL WITHIN EXISTING R/W SHALL BE IN ACCORDANCE WITH LATEST MUTCD OR FDOT STANDARDS FOR CONTROL OF TRAFFIC THROUGH WORK ZONES.
3. NO WORK SHALL BE DONE NOR MATERIALS USED IN THE RIGHT-OF-WAY WITHOUT INSPECTION BY THE CITY. THE CONTRACTOR SHALL FURNISH THE CITY WITH EVERY REASONABLE FACILITY FOR ASCERTAINING WHETHER THE WORK PERFORMED AND MATERIALS USED ARE IN ACCORDANCE WITH THE REQUIREMENTS AND INTENT OF THE PLANS AND SPECIFICATIONS.
4. CITY OF LAKE CITY RESERVES THE RIGHT TO MODIFY THE PROPOSED WORK WITHIN THEIR RIGHT-OF-WAY TO ENSURE COMPATIBILITY WITH EXISTING IMPROVEMENTS. SUCH MODIFICATION COSTS SHALL BE BORNE BY THE CONTRACTOR.
5. ALL DISTURBED AREAS WITHIN THE RIGHT-OF-WAY SHALL BE SEEDED UNLESS SODDING IS OTHERWISE SPECIFIED. SODDING IS REQUIRED ON ALL SLOPES 4:1 OR STEEPER.
6. ALL WORK WITHIN OR ON CITY OF LAKECITY OWNED AND MAINTAINED FACILITIES, ROW OR EASEMENTS WILL REQUIRE AS-BUILT PLANS. AS-BUILT PLANS SHOULD SHOW THE CONSTRUCTED CONDITIONS OF THE CITY OWNED OR MAINTAINED AREA AND SHALL BE PER FDOT STANDARDS AND PROCEDURES AND BE PERFORMED BY A FLORIDA LICENSED PROFESSIONAL SURVEYOR AND MAPPER.
7. INSTALLATION OR CONSTRUCTION OF MAILBOXES, PRIVATE IRRIGATION PIPING, OR PRIVATE UTILITY CHASES, ETC. IN PUBLIC RIGHT OF WAYS UNDER CITY OWNERSHIP SHALL REQUIRE A RIGHT OF WAY USE PERMIT PRIOR TO BEGINNING.

STANDARD ABBREVIATIONS

Table with 2 columns: Abbreviation and Full Name. Includes terms like ALACHUA COUNTY PUBLIC WORKS, ADJACENT, ALUMINUM, APARTMENT, ASPHALT, etc.

Table with 2 columns: Abbreviation and Full Name. Includes terms like LOW POINT, LEFT, MAINTENANCE, MAXIMUM, MITERED END SECTION, etc.

LEGEND

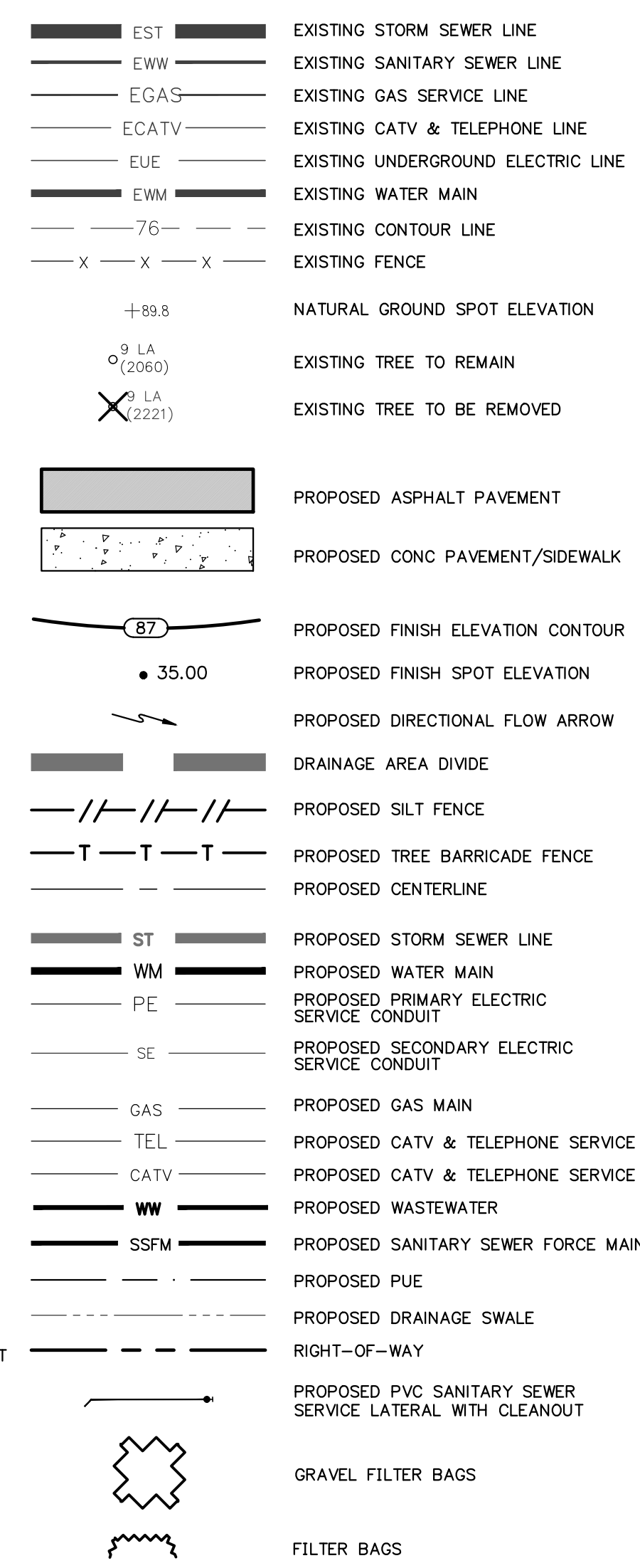

PAVING, GRADING AND DRAINAGE SPECIFICATIONS

- 1. ALL DRAINAGE CONSTRUCTION, INCLUDING MATERIALS, CONSTRUCTION TECHNIQUES, AND TECHNICAL STANDARDS, SHALL BE IN ACCORDANCE WITH THE FDOT FY 2020-21 STANDARD PLANS.
2. ALL AREAS OF NEW CONSTRUCTION SHALL BE CLEANED AND GRUBBED. TOP SOIL REMAINING ONSITE MAY BE STOCKPILED FOR FINE GRADING IN LANDSCAPED AREAS, IF SUITABLE. THE CONTRACTOR SHALL FURNISH ALL FILL REQUIRED AND DISPOSE OF ALL EXCESS OR UNSUITABLE MATERIAL OFFSITE IN ACCORDANCE WITH ALL REGULATORY REQUIREMENTS. TREES TO REMAIN SHALL BE PROTECTED PRIOR TO STARTING CONSTRUCTION AND SHALL BE PROTECTED THROUGHOUT SITE CONSTRUCTION.
3. ALL PROPOSED UNDERGROUND UTILITY INSTALLATIONS WITHIN THE LIMITS OF ROADWAY SUBGRADE, INCLUDING STORMWATER, POTABLE WATER, WASTEWATER, GAS, ELECTRICAL CONDUIT, AND SLEEVES FOR FUTURE UTILITIES, SHALL BE INSTALLED PRIOR TO STABILIZATION OF THE ROADWAY SUBGRADE.
4. ALL NEW ASPHALT PAVEMENT CONSTRUCTION SHALL CONFORM TO THE FOLLOWING SPECIFICATIONS:
A. EARTHWORK: FILL MATERIALS SHALL CONFORM TO AASHTO SOIL GROUPS A-1, A-2, A-3, OR A-4 AND SHALL BE PLACED IN 6" - 12" LOOSE LIFTS AND COMPACTED TO 95% DENSITY USING MODIFIED PROCTOR METHOD (AASHTO T-180).
B. SUBSOIL EXCAVATION: THE LIMITS OF SUBSOIL EXCAVATION SHALL BE IN ACCORDANCE WITH THE RECOMMENDATIONS OF THE GEOTECHNICAL REPORT. EXACT LOCATIONS OF SUBSOIL EXCAVATION SHALL BE AS DIRECTED BY THE CITY OF LIVE OAK OR THE GEOTECHNICAL ENGINEER.
C. STABILIZED SUBGRADE: ALL STABILIZED MATERIAL SHALL CONFORM TO SECTION 914 AND PLACED ACCORDING TO SECTION 160 IN ONE 12" MINIMUM COMPACTED LIFT. SUBGRADE SHALL BE STABILIZED TO A MINIMUM LBR VALUE OF 40 PER DESIGN SECTION.
D. BASE COURSE: ALL MATERIAL SHALL BE LIMESTONE CONFORMING TO SECTION 911 AND PLACED ACCORDING TO SECTION 200 IN A SINGLE OR TWO EQUAL COMPACTED LIFTS (PER DESIGN SECTION). BASE MATERIAL SHALL BE COMPACTED TO 98% DENSITY BY MODIFIED PROCTOR METHOD (AASHTO T-180). THE PRIME COAT SHALL CONFORM TO SECTION 300.
E. ASPHALTIC CONCRETE: ALL ASPHALTIC CONCRETE MATERIAL SHALL BE TYPE SP STRUCTURAL COURSE (TYPE & THICKNESS PER DESIGN SECTION) AND SHALL CONFORM TO SECTION 334. ALL ASPHALTIC CONCRETE CONSTRUCTION SHALL CONFORM TO SECTION 330.
5. ALL CONCRETE USED FOR CONSTRUCTION OF DRAINAGE STRUCTURES, SIDEWALKS, SPILLWAYS, CURBING, ETC. SHALL BE CLASS 1 CONFORMING TO SECTION 347.
6. CONCRETE SIDEWALKS AND DRIVEWAYS SHALL BE CONSTRUCTED IN ACCORDANCE WITH SECTION 522.
7. CONCRETE CURB AND GUTTER SHALL BE CONSTRUCTED IN CONFORMANCE TO SECTION 520.
8. REINFORCED CONCRETE PIPE (RCP) SHALL CONFORM TO SECTION 449-4.
9. HIGH DENSITY POLY ETHYLENE (HDPE) SHALL CONFORM TO SECTION 431-2.3 AND 431-3.3.
10. ALL SLOPES OF 4:1 OR GREATER SHALL BE SODDED.

REVISIONS table with columns for NO, DATE, DESCRIPTION, DRWN, and APPR.

Professional Engineer Seal for Christopher A. Potts, P.E., Florida License No. 73842.

JBPro CIVIL ENGINEERING | LAND PLANNING SURVEYING | CONSTRUCTION SERVICES

3530 NW 43rd Street | Gainesville, Florida 32606
4420 US-1 S, Suite 1 | St. Augustine, Florida 32086
Gainesville: (352) 375-8999 | St. Augustine: (904) 789-8999
Toll Free: (844) Go-JBPro | E-mail: contact@jbpro.com

SHEET TITLE: LEGENDS, ABBREVIATIONS, AND NOTES
CLIENT: HIGH COTTON EQUITIES, LLC

PROJECT: RIB CRIB RESTAURANT LAKE CITY, FLORIDA

DATE: JUNE 2022
PROJECT NO: 366-22-03
SHEET NO: C0.1

LOT 7
GATEWAY CROSSING
P.B. 9, PG. 114



COMMON AREA 1
GATEWAY CROSSING
P.B. 9, PG. 114

LOT 9
GATEWAY CROSSING
P.B. 9, PG. 114

GENERAL DEMOLITION NOTES

1. PRIOR TO DEMOLITION AND CONSTRUCTION, THE CONTRACTOR SHALL CONTACT THE APPROPRIATE UTILITY COMPANIES TO VERIFY THE LOCATION OF ALL ABOVE GROUND AND UNDERGROUND UTILITIES TO BE REMOVED OR RELOCATED.
2. CONTRACTOR IS RESPONSIBLE FOR ALL SITE DEMOLITION AND MATERIAL REMOVAL. IN ADDITION TO THE DEMOLITION SHOWN, THE CONTRACTOR SHALL REMOVE ALL MISCELLANEOUS TRASH, DEBRIS, FENCING ETC., IN ORDER TO PROVIDE A CLEAN CONSTRUCTION SITE.
3. CONTRACTOR IS RESPONSIBLE FOR DISPOSING OF ALL DEMOLITION MATERIAL OFF SITE. DISPOSAL METHODS AND LOCATIONS SHALL BE IN ACCORDANCE WITH ALL APPLICABLE LOCAL, STATE, AND FEDERAL REQUIREMENTS.
4. REMOVAL OF ALL CONSTRUCTION DEBRIS, LIMESTONE, EXCESS OF BUILDERS SAND, CONCRETE AND MORTAR DEBRIS, EXISTING WEEDS AND GRASSES, AND ALL FOREIGN MATERIALS IN THE PLANTING BED AND SOO AREAS IS THE RESPONSIBILITY OF THE SITE WORK CONTRACTOR. SOIL IN AREAS TO BE LANDSCAPED SHALL BE UNCOMPACTED, SUITABLE FOR ROOT GROWTH WITH APPROPRIATE AMOUNTS OF ORGANIC MATTER, AND OF PH RANGE OF 5.5 - 6.5.
5. ALL OFF SITE TREES SHALL REMAIN UNLESS OTHERWISE NOTED.
6. PRIOR TO CONSTRUCTION THE CONTRACTOR SHALL DESIGNATE A TEMPORARY CONSTRUCTION ENTRANCE AND STOCKPILE AREA.
7. EXISTING SIGNS SHALL BE REMOVED AND STORED DURING DEMOLITION SO THAT THEY CAN BE REINSTALLED DURING CONSTRUCTION.

LEGEND

-  EXISTING HARDSCAPE TO BE REMOVED
-  EXISTING CURB TO BE REMOVED
-  SAWCUT EXISTING ASPHALT PAVEMENT

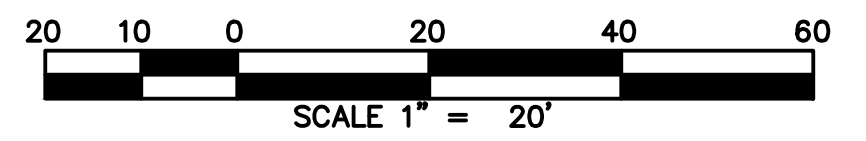
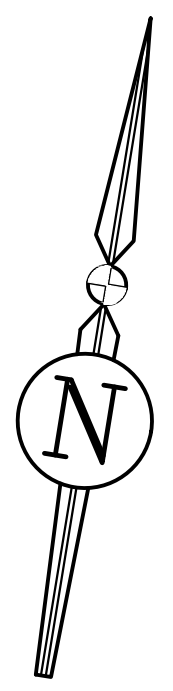
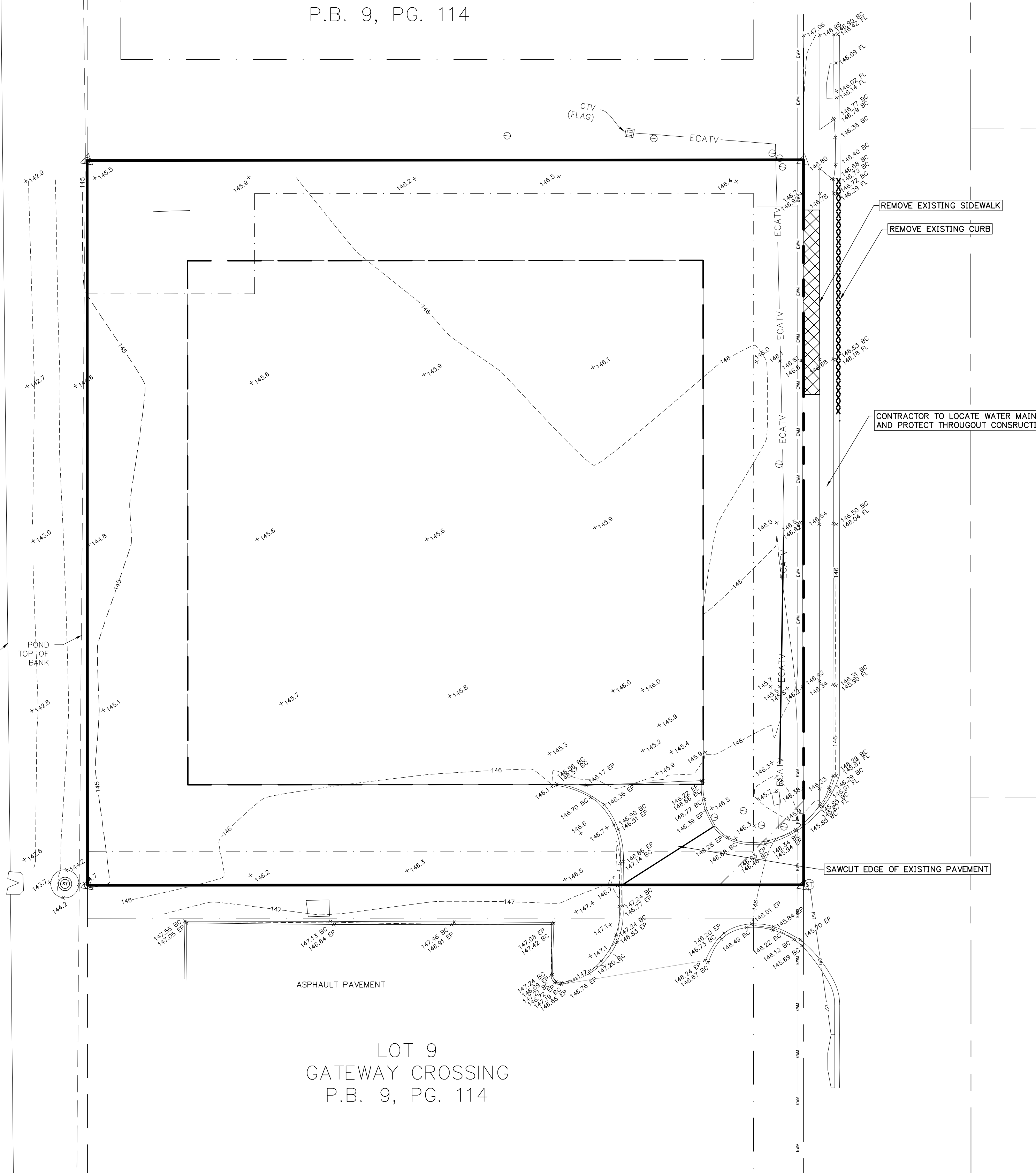

REVISIONS			DRWN	APPR
NO.	DATE	DESCRIPTION		

ENGINEER OF RECORD:
CHRISTOPHER A. POTTS, P.E.
FLORIDA LICENSE NO. 73842

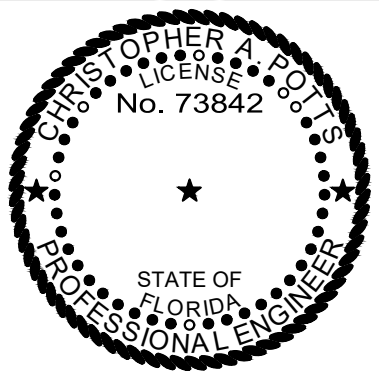

JBPro
CIVIL ENGINEERING | LAND PLANNING
SURVEYING | CONSTRUCTION SERVICES

3530 NW 43rd Street | Gainesville, Florida 32606
4420 US-1 S, Suite 1 | St. Augustine, Florida 32086
Gainesville: (352) 375-8999 | St. Augustine: (904) 789-8999
Toll Free: (844) Go-JBPro | E-mail: contact@jbpro.com

SHEET TITLE:
DEMOLITION PLAN
CLIENT:
HIGH COTTON EQUITIES, LLC

PROJECT:
RIB CRIB RESTAURANT
LAKE CITY, FLORIDA

DATE:
JUNE 2022
PROJECT NO:
366-22-03
SHEET NO:
C1.0

LOT 7
GATEWAY CROSSING
P.B. 9, PG. 114

COMMON AREA 1
GATEWAY CROSSING
P.B. 9, PG. 114

LOT 9
GATEWAY CROSSING
P.B. 9, PG. 114

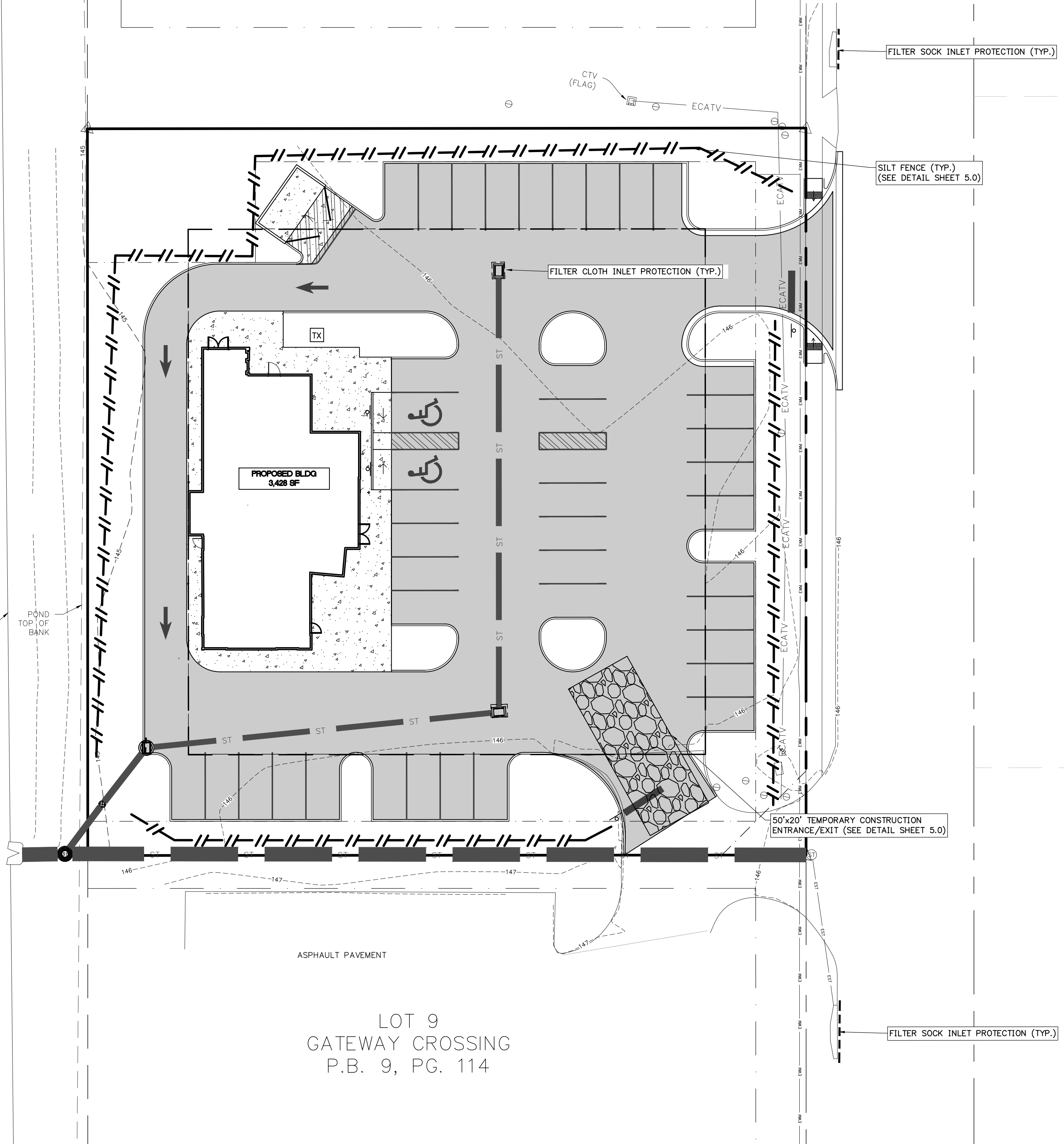

EROSION AND SEDIMENTATION CONTROL NOTES

1. THE CONTRACTOR SHALL UTILIZE THE EROSION AND SEDIMENTATION CONTROL PLAN AS A GENERAL GUIDE AND DIRECTION FOR MINIMUM CONTROL MEASURES. CONTRACTOR SHALL UTILIZE EROSION CONTROL BEST MANAGEMENT PRACTICES (BMP'S) AS REQUIRED TO MINIMIZE EROSION AND SEDIMENTATION BUILDUP ON-SITE AND TO PREVENT EROSION AND SEDIMENTATION DISCHARGE OFF PROPERTY.
2. CONTRACTOR SHALL EMPLOY AN FDEP CERTIFIED EROSION AND SEDIMENTATION CONTROL INSPECTOR TO MONITOR THE CONTRACTOR'S EROSION AND SEDIMENTATION CONTROL WORK EFFORT THROUGHOUT CONSTRUCTION.
3. DURING CONSTRUCTION, NO DIRECT DISCHARGE OF WATER TO DOWNSTREAM RECEIVING WATERS WILL BE ALLOWED. THE CONTRACTOR IS RESPONSIBLE FOR MAINTAINING WATER QUALITY, AND SHALL ROUTE DISCHARGE WATER IN SUCH A MANNER TO ADEQUATELY REMOVE SILT PRIOR TO RUNOFF FROM THE SITE.
4. SILT FENCING AND OTHER SEDIMENT CONTROL MEASURES SHALL BE CONSTRUCTED WHERE SHOWN ON THE DRAWINGS PRIOR TO STARTING CONSTRUCTION. ALL STORM DRAIN INLETS SHALL BE PROTECTED DURING CONSTRUCTION IN ACCORDANCE WITH FDOT EROSION AND SEDIMENTATION CONTROL DESIGNER AND REVIEWER MANUAL (JUNE 2007) TO PREVENT SEDIMENT DISCHARGE TO THE EXISTING STORMWATER MANAGEMENT SYSTEM.
5. THE RETENTION BASINS SHALL BE PROTECTED FROM SEDIMENT DISCHARGE BY SILT FENCE AT THE DISCHARGE STORM STRUCTURE. CAREFUL ATTENTION SHALL BE PAID TO PREVENT EROSION FROM ENTERING THE BASIN BOTTOM BEYOND THE IMMEDIATE EXIT OF THE STRUCTURE. REMOVE ALL SEDIMENT BUILDUP AT THE DISCHARGE STRUCTURE REGULARLY THROUGHOUT CONSTRUCTION.
6. PROTECT EXISTING STORMWATER INLET STRUCTURES WITH FILTER FABRIC OR OTHER EROSION CONTROL DEVICE TO PREVENT SEDIMENTS FROM ENTERING STORM SEWER SYSTEM.
7. ALL EROSION AND SEDIMENTATION CONTROL STRUCTURES SHALL BE INSPECTED AT LEAST ONCE PER WEEK AND AFTER 1/2" OR GREATER RAINFALL. ANY DEFICIENCIES DISCOVERED SHALL BE REPAIRED, ADJUSTED, OR IMPROVED AS REQUIRED.
8. ALL EROSION AND SEDIMENTATION CONTROL STRUCTURES SHALL BE MAINTAINED UNTIL CONSTRUCTION IS COMPLETE AND APPROVED, AND VEGETATION IS FULLY ESTABLISHED.
9. CONTRACTOR SHALL MINIMIZE AIR POLLUTION FROM PARTICULATES AND DUST. WATER SHALL BE APPLIED AS NEEDED TO REDUCE DUST DURING CONSTRUCTION. USE OTHER STABILIZATION METHODS SUCH AS HYDROMULCHING AS NEEDED.
10. CONTRACTOR SHALL STOCKPILE AND STORE MATERIALS SUCH THAT STORMWATER FLOW IS NOT IMPEDED DURING CONSTRUCTION AND MATERIAL EROSION DOES NOT OCCUR.
11. ALL DISTURBED OPEN AREAS WITHIN THE PROJECT CONSTRUCTION LIMITS SHALL BE COMPLETELY GRASSED BY COMPLETION OF CONSTRUCTION. GRASS SEEDING RATES AND MIXTURES SHALL BE PER FDOT EROSION AND SEDIMENTATION CONTROL DESIGNER AND REVIEWER MANUAL (JULY 2013). EVIDENCE OF GROWTH MUST BE PRESENT PRIOR TO FINAL RELEASE.
12. THE STORM SEWER SYSTEM SHALL BE FLUSHED OUT TO REMOVE ALL ACCUMULATED DEBRIS AND SEDIMENT UPON COMPLETION OF CONSTRUCTION.

LEGEND

- //— SILT-FENCE BARRIERS PER FDOT EROSION AND SEDIMENT CONTROL DESIGNER AND REVIEWER MANUAL (JUNE 2007)
- FILTER CLOTH INLET PROTECTION
- — — — — FILTER SOCK INLET PROTECTION

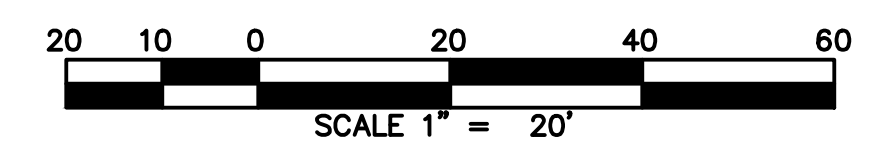
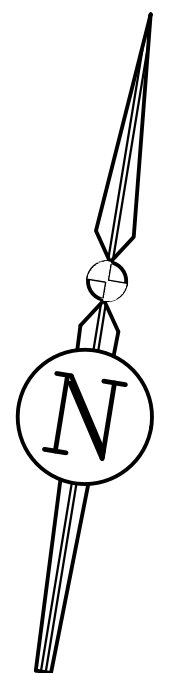

REVISIONS			
NO.	DATE	DESCRIPTION	DRWN/ APPR

ENGINEER OF RECORD: CHRISTOPHER A. POTTS, P.E.
FLORIDA LICENSE NO. 73842

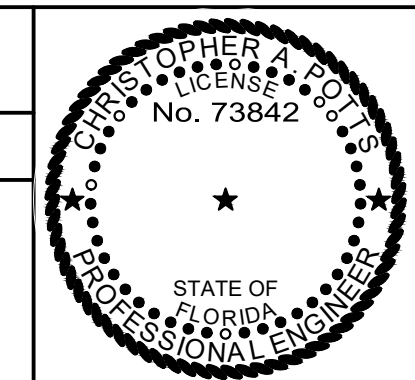

JBPro
CIVIL ENGINEERING | LAND PLANNING
SURVEYING | CONSTRUCTION SERVICES

3530 NW 43rd Street | Gainesville, Florida 32606
4420 US-1 S, Suite 1 | St. Augustine, Florida 32086
Gainesville: (352) 375-8999 | St. Augustine: (904) 789-8999
Toll Free: (844) Go-JBPro | E-mail: contact@jbpro.com

SHEET TITLE: **EROSION AND SEDIMENTATION CONTROL PLAN**
CLIENT: HIGH COTTON EQUITIES, LLC
PROJECT: RIB CRIB RESTAURANT
LAKE CITY, FLORIDA



DATE: JUNE 2022
PROJECT NO: 366-22-03
SHEET NO: **C1.1**

DIMENSION NOTES

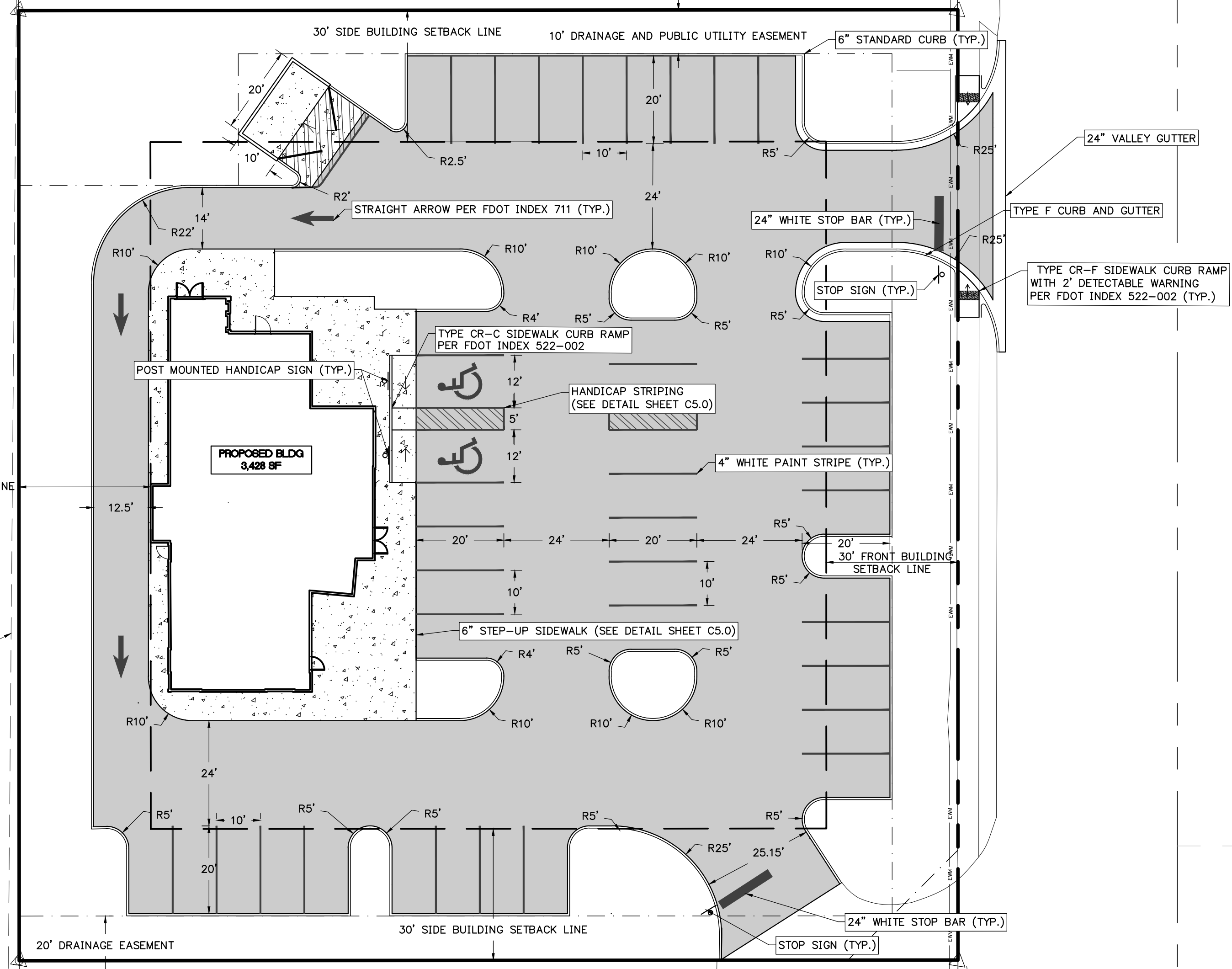
1. CONTRACTOR SHALL FAMILIARIZE THEMSELVES WITH THE PROJECT SURVEY AND DESIGN DRAWINGS, AND SHALL VERIFY EXISTING SITE CONDITIONS. ANY APPARENT DISCREPANCIES OR ADDITIONAL PERTINENT INFORMATION SHALL BE BROUGHT TO THE PROJECT ENGINEER'S ATTENTION IMMEDIATELY.
2. ALL DIMENSIONS AND RADII SHOWN ARE DIMENSIONED TO EDGE OF PAVEMENT OR FACE OF CURB, UNLESS OTHERWISE SPECIFIED.
3. ALL STRIPING SHALL CONFORM TO FDOT STANDARD INDEX 711-001.
4. TOTAL NUMBER OF PARKING SPACES = 42 (2 HANDICAP PARKING SPACES)



LEGEND

-  NEW ASPHALT PAVEMENT
-  NEW CONCRETE

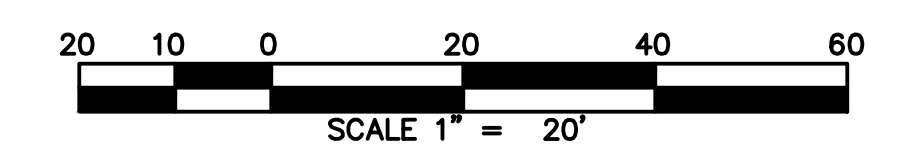
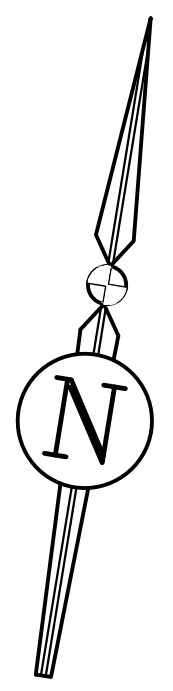

J:\366-22-03 - Gateway Crossing Lot B - RibCrib - BEQ Production\CA Sheets\C2.0 - Dimension Plan.dwg, 6/27/2022 10:21:35 AM, Admin

REVISIONS

NO.	DATE	DESCRIPTION	DRWN	APPR

ENGINEER OF RECORD: **CHRISTOPHER A. POTTS, P.E.**
 FLORIDA LICENSE NO. 73842

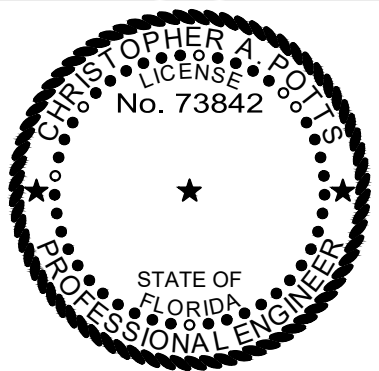

JBPro
 CIVIL ENGINEERING | LAND PLANNING
 SURVEYING | CONSTRUCTION SERVICES

3530 NW 43rd Street | Gainesville, Florida 32606
 4420 US-1 S, Suite 1 | St. Augustine, Florida 32086
 Gainesville: (352) 375-8999 | St. Augustine: (904) 789-8999
 Toll Free: (844) Go-JBPro | E-mail: contact@jbpro.com

SHEET TITLE: **DIMENSION PLAN**
 CLIENT: **HIGH COTTON EQUITIES, LLC**

PROJECT: **RIB CRIB RESTAURANT
LAKE CITY, FLORIDA**

DATE: **JUNE 2022**
 PROJECT NO: **366-22-03**
 SHEET NO: **C2.0**

STORM STRUCTURE TABLE

EX-01
EXISTING STORM MANHOLE
RIM EL = 142.96
NE INV EL = 140.50 (18" EXISTING RCP)
W INV EL = 138.00 (42" EXISTING RCP)
E INV EL = 138.50 (42" EXISTING RCP)

S-01
INDEX NO. 425-024 TYPE 9 CURB INLET
PWT EL = 145.35
E INV EL = 140.72 (15" RCP)
SW INV EL = 140.62 (18" RCP)

S-02
INDEX NO. 425-052 TYPE C INLET
GRATE EL = 145.32
W INV EL = 141.12 (15" RCP)
N INV EL = 141.22 (15" RCP)

S-03
INDEX NO. 425-052 TYPE C INLET
GRATE EL = 145.15
S INV EL = 141.62 (15" RCP)

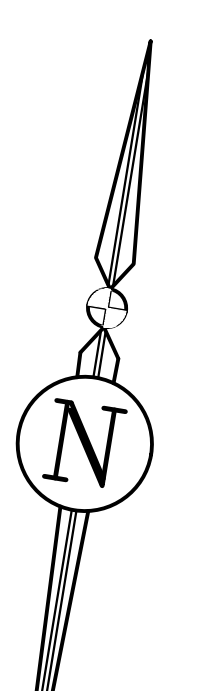
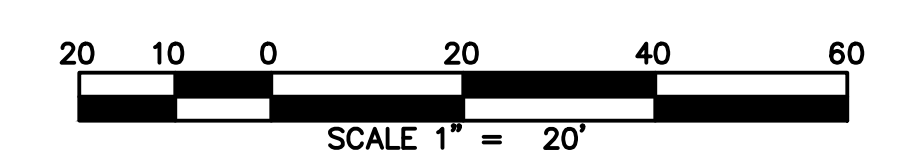
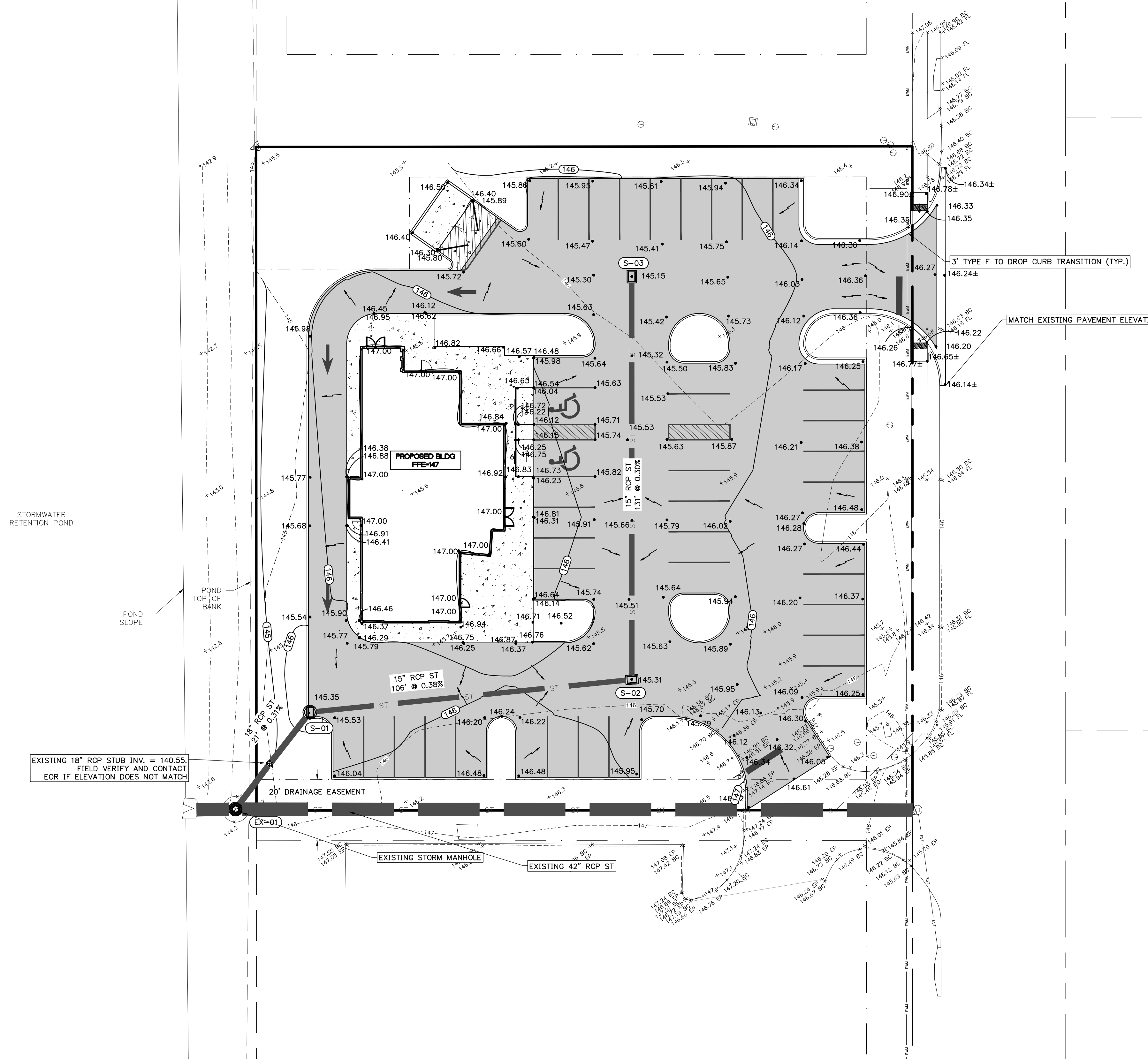

REVISIONS			DRWN	APPR
NO.	DATE	DESCRIPTION		

ENGINEER OF RECORD:
CHRISTOPHER A. POTTS, P.E.
FLORIDA LICENSE NO. 73842

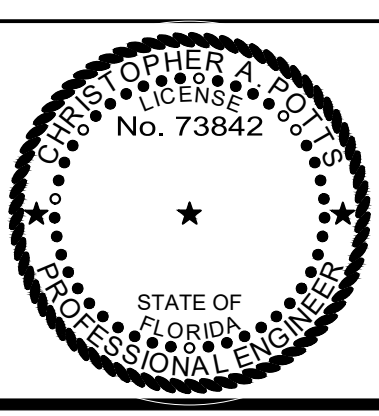

JBPro
CIVIL ENGINEERING | LAND PLANNING
SURVEYING | CONSTRUCTION SERVICES

3530 NW 43rd Street | Gainesville, Florida 32606
4420 US-1 S, Suite 1 | St. Augustine, Florida 32086
Gainesville: (352) 375-8999 | St. Augustine: (904) 789-8999
Toll Free: (844) Go-JBPro | E-mail: contact@jbpro.com

SHEET TITLE:
PAVING, GRADING, AND DRAINAGE PLAN

CLIENT:
HIGH COTTON EQUITIES, LLC

PROJECT:
RIB CRIB RESTAURANT
LAKE CITY, FLORIDA

DATE:
JUNE 2022

PROJECT NO:
366-22-03

SHEET NO:
C3.0

J:\366-22-03 - Gateway Crossing Lot B - RibCrib - BEQ Production\CA Potts\366-22-03 - Paving, Grading and Drainage Plan.dwg, 6/27/2022, 10:21:42 AM, Abrom

GENERAL NOTES:

1. ALL POTABLE WATER MAINS SHALL BE AWWA DR-18, C900 PVC, SCH 80 PVC OR DR-11 HDPE.
2. ALL WASTEWATER GRAVITY MAINS SHALL BE ASTM D-1785, SDR 26 PVC. ALL WASTEWATER FORCE MAINS SHALL BE AWWA DR-18, C900 PVC, SCH 80 PVC OR DR-11 HDPE.
3. ALL WATER MAINS SHALL HAVE AT LEAST 30" OF COVER.
4. THE WATER METER SHALL BE THE END OF CITY OF LIVE OAK MAINTENANCE FOR POTABLE WATER.
5. CONTRACTOR TO VERIFY DEPTH OF EXISTING SEWER AT THE PROPOSED CONNECTION POINT PRIOR TO COMMENCEMENT OF UTILITY WORK. IF THE ELEVATION OF THE EXISTING PIPE IS NOT A MINIMUM DEPTH OF 115.76, CONTRACTOR TO CONTACT EOR.

LIGHTING NOTES:

1. ALL EXTERIOR LIGHTING WILL BE DIRECTED SO THAT NO GLARE IS VISIBLE FROM ANY STREET ROW OR FROM ANY ADJACENT RESIDENTIAL PROPERTIES.

WATER FITTING SCHEDULE

- ① 1 - 1" WATER METER ASSEMBLY
1 - 1.5" RPZBFP
- ② 1 - 2" PVC 45 DEGREE BEND

WASTEWATER PIPE TABLE

UPSTREAM STRUCTURE	DOWNSTREAM STRUCTURE	SIZE & MATERIAL	LENGTH	SLOPE
WW-CO-1	WW-CO-2	4" PVC	18'	1.08%
WW-CO-2	WW-GT-IN	4" PVC	2'	1.00%
WW-CO-3	WW-CO-4	6" PVC	30'	0.60%
WW-CO-4	EX-WW-CO	6" PVC	57'	3.09%
WW-CO-5	WW-CO-6	4" PVC	5'	1.04%
WW-CO-6	WW-CO-3	4" PVC	18'	1.91%
WW-GT-OUT	WW-CO-3	4" PVC	2'	1.00%

WW CLEANOUT TABLE

WWCO	TOP EL.	INV EL.
EX-WW-CO	145.86	140.50
• WW-CO-1	146.37	142.85
WW-CO-2	145.53	142.66
WW-CO-3	145.53	142.45
WW-CO-4	145.40	142.27
• WW-CO-5	146.38	142.85
• WW-CO-6	146.91	142.80

* -CLEANOUTS LOCATED IN PAVED AREA(S) WILL HAVE TRAFFIC LOAD BEARING COVERS

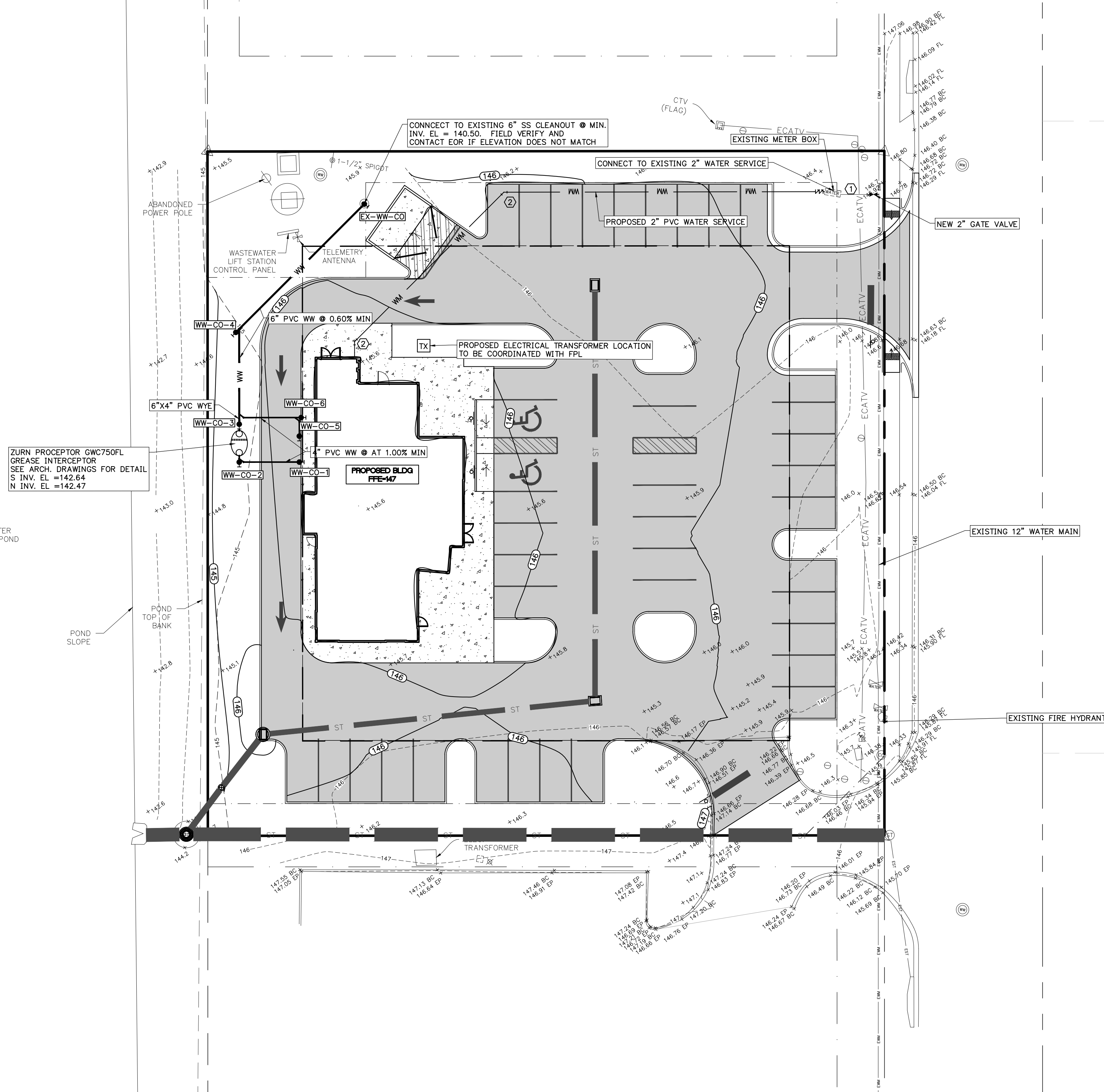
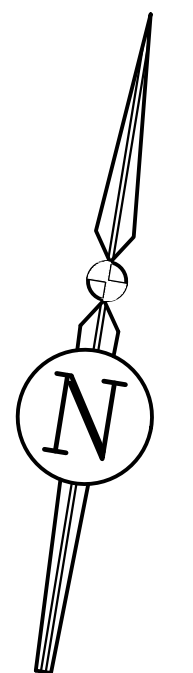
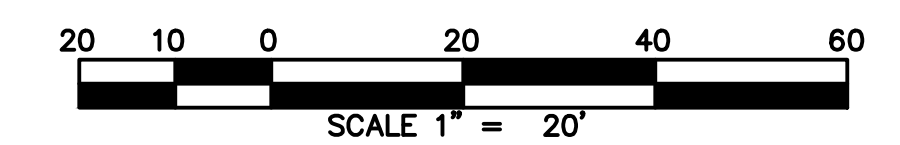

ZURN PROCEPTOR GWC750FL GREASE INTERCEPTOR SEE ARCH. DRAWINGS FOR DETAILS S INV. EL = 142.64 N INV. EL = 142.47

STORMWATER RETENTION POND

POND TOP OF BANK POND SLOPE

REVISIONS

NO.	DATE	DESCRIPTION	DRWN	APPR

ENGINEER OF RECORD: CHRISTOPHER A. POTTS, P.E. FLORIDA LICENSE NO. 73842

JBPro
CIVIL ENGINEERING | LAND PLANNING
SURVEYING | CONSTRUCTION SERVICES

3530 NW 43rd Street | Gainesville, Florida 32606
4420 US-1 S, Suite 1 | St. Augustine, Florida 32086
Gainesville: (352) 375-8999 | St. Augustine: (904) 789-8999
Toll Free: (844) Go-JBPro | E-mail: contact@jbpro.com

SHEET TITLE: **UTILITY PLAN**
CLIENT: HIGH COTTON EQUITIES, LLC

PROJECT: RIB CRIB RESTAURANT LAKE CITY, FLORIDA

DATE: JUNE 2022
PROJECT NO: 366-22-03
SHEET NO: **C4.0**

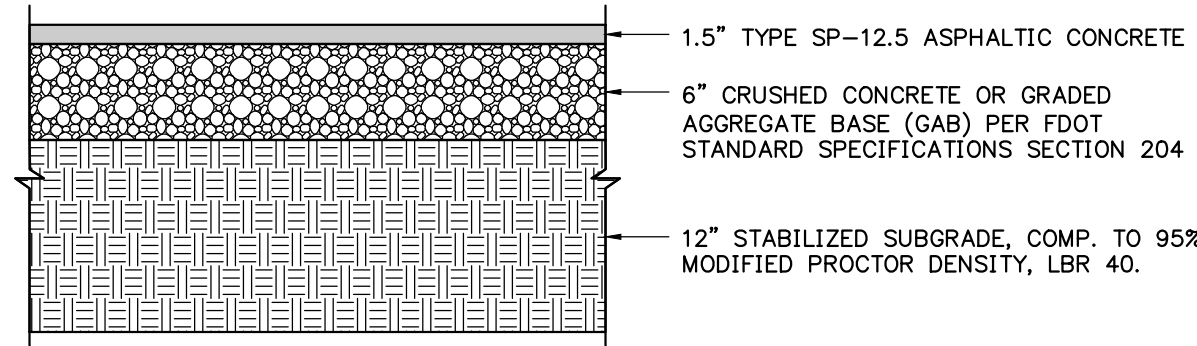

(LIGHT DUTY) TYPICAL ASPHALT PAVEMENT DETAIL

N.T.S.

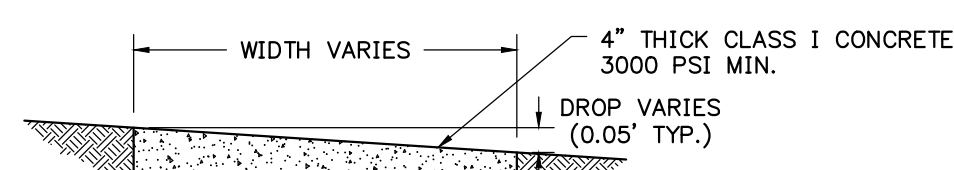

TYPICAL AT GRADE SIDEWALK DETAIL

N.T.S.

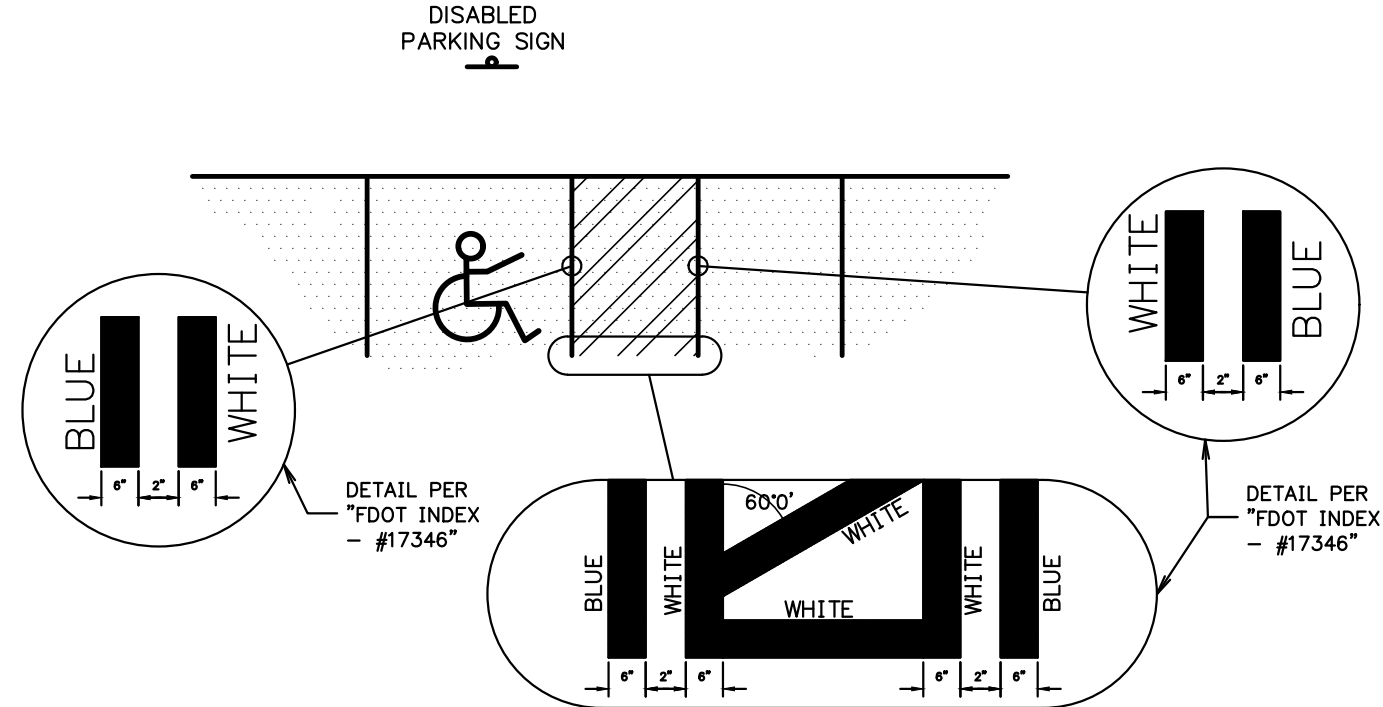

HANDICAP STRIPING DETAIL

N.T.S.

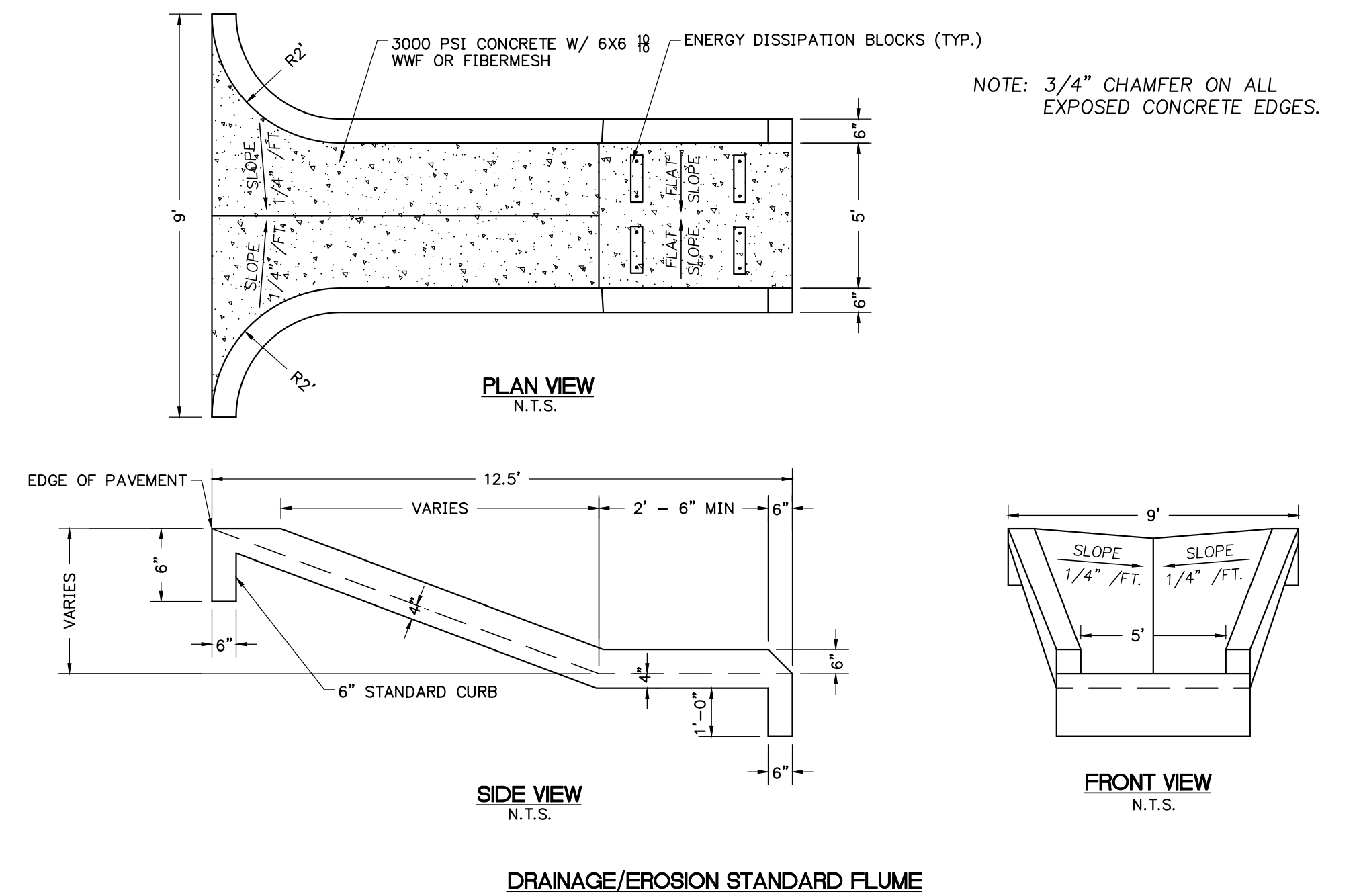

DRAINAGE/EROSION STANDARD FLUME

N.T.S.

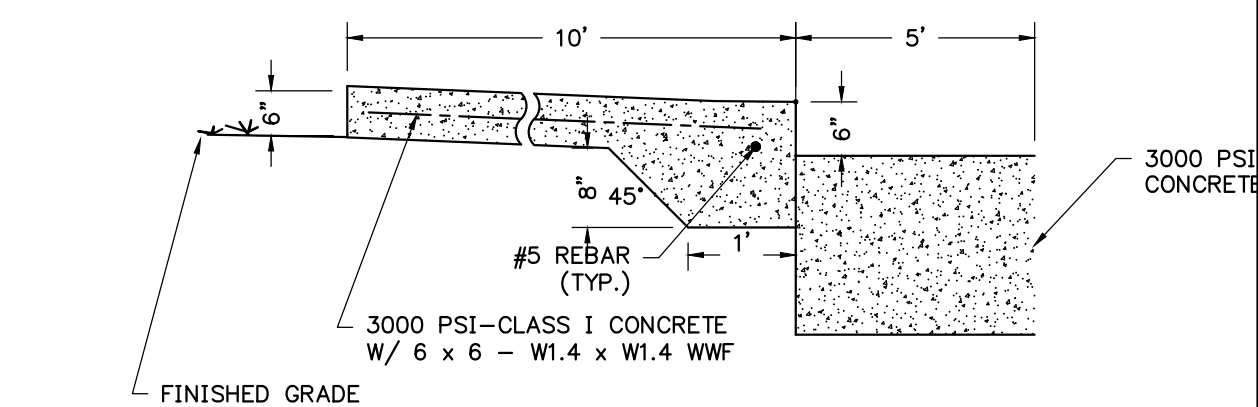

CONCRETE DUMPSTER PAD DETAIL

N.T.S.

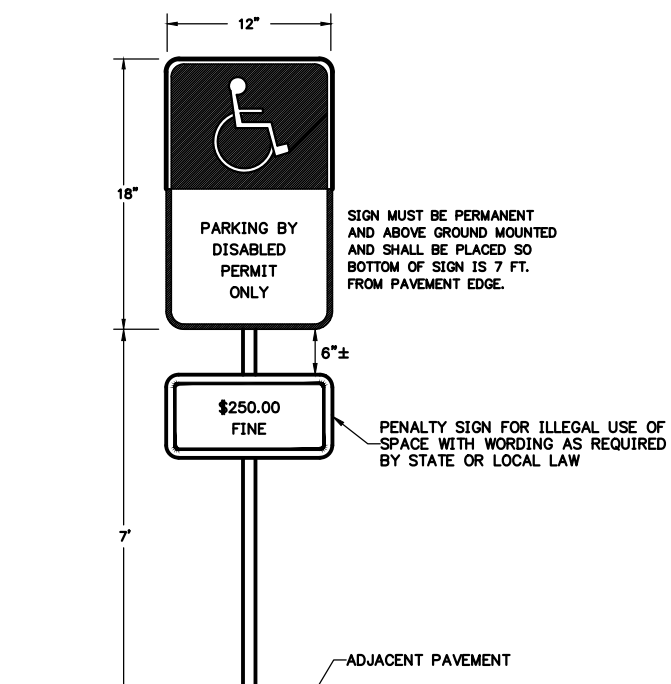

DISABLED PARKING SPACE SIGN DETAIL

N.T.S.

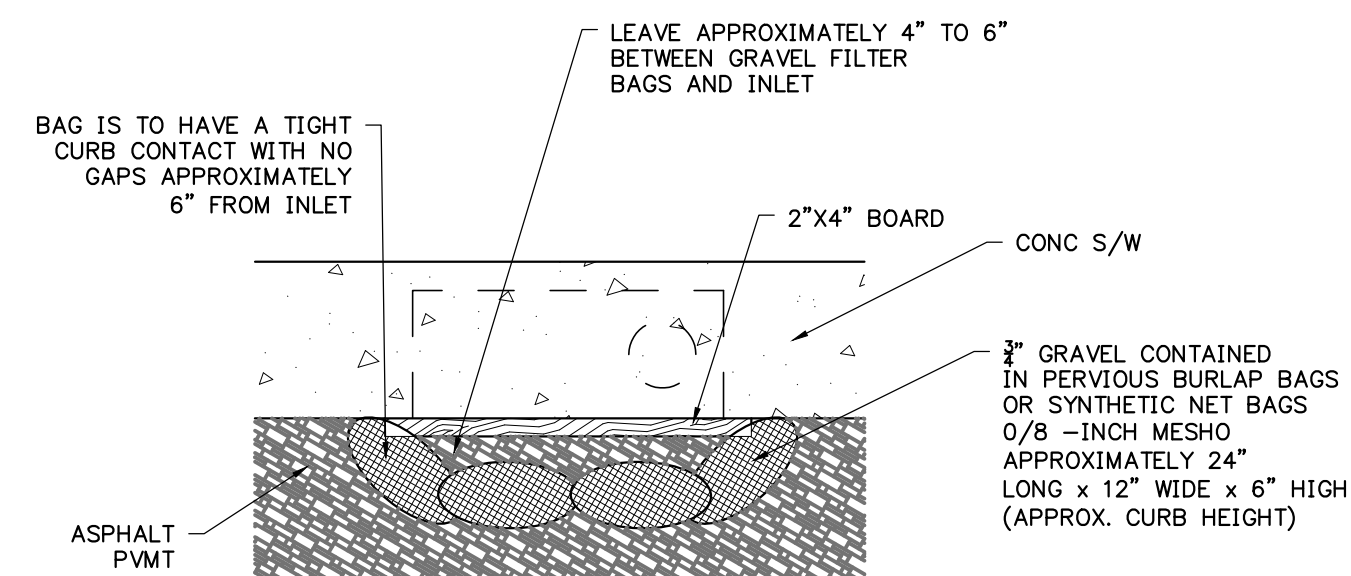

PLAN VIEW

HEIGHT OF GRAVEL FILTER BAGS SHOULD NOT BE ABOVE THE CONCRETE S/W

ELEVATION

NOTE: GRAVEL FILTERS CAN BE USED ON PAVEMENT OR BARE GROUND.

GRAVEL FILTER BAGS DETAIL

N.T.S.

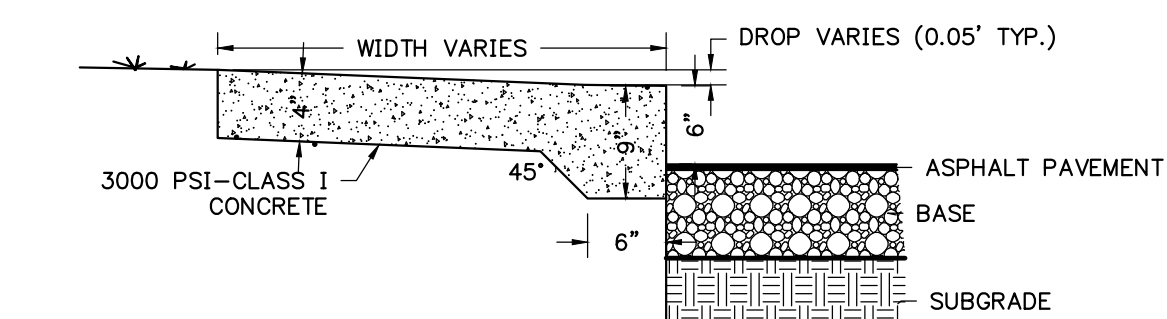

TYPICAL STEP-UP SIDEWALK DETAIL

N.T.S.

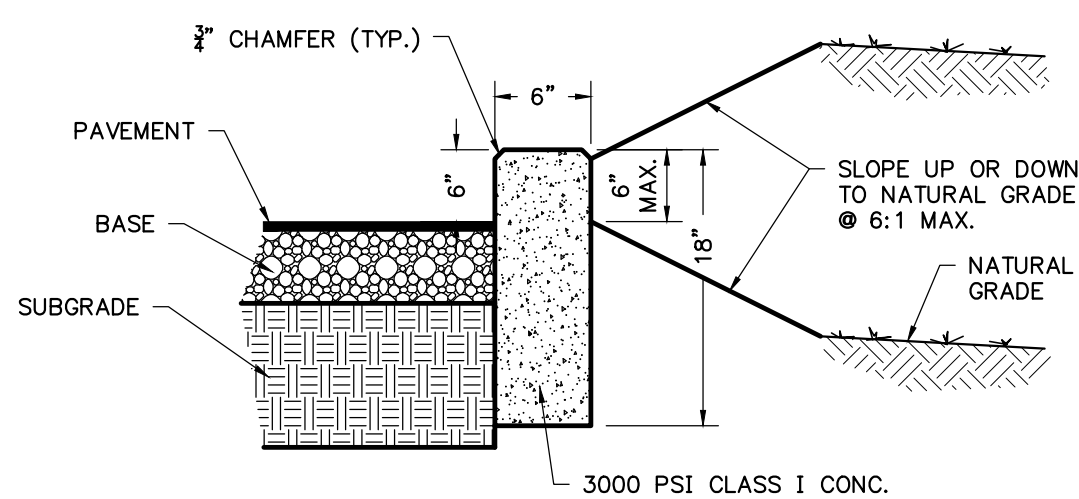

STANDARD CURB DETAIL

N.T.S.

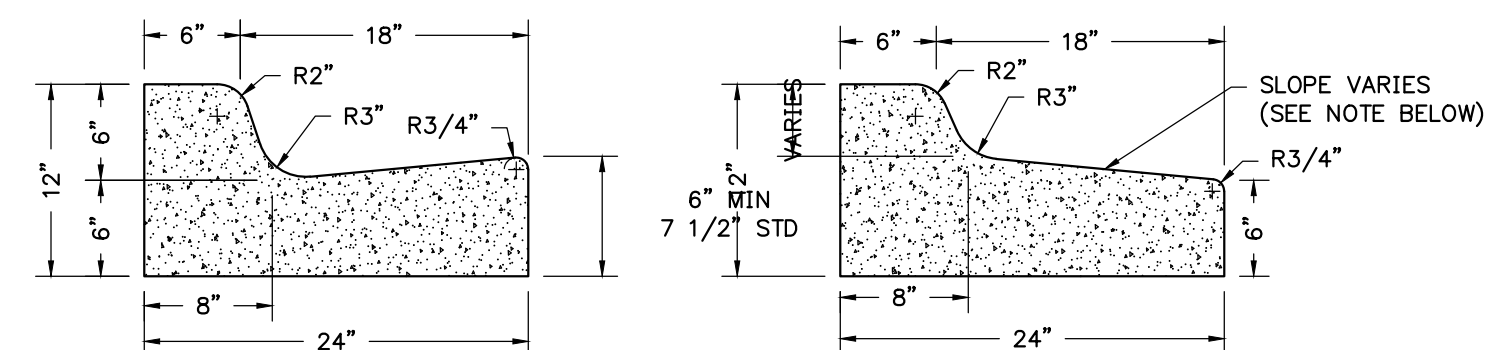

STANDARD

SPILL-OUT

NOTE: WHEN USED ON THE HIGH SIDE OF ROADWAYS, THE CROSS-SLOPE OF THE GUTTER SHALL MATCH THE CROSS-SLOPE OF THE ADJACENT PAVEMENT AND THE THICKNESS OF THE LIP SHALL BE 6", UNLESS OTHERWISE SHOWN ON THE PLANS.

TYPE 'F' CONCRETE CURB AND GUTTER

N.T.S.

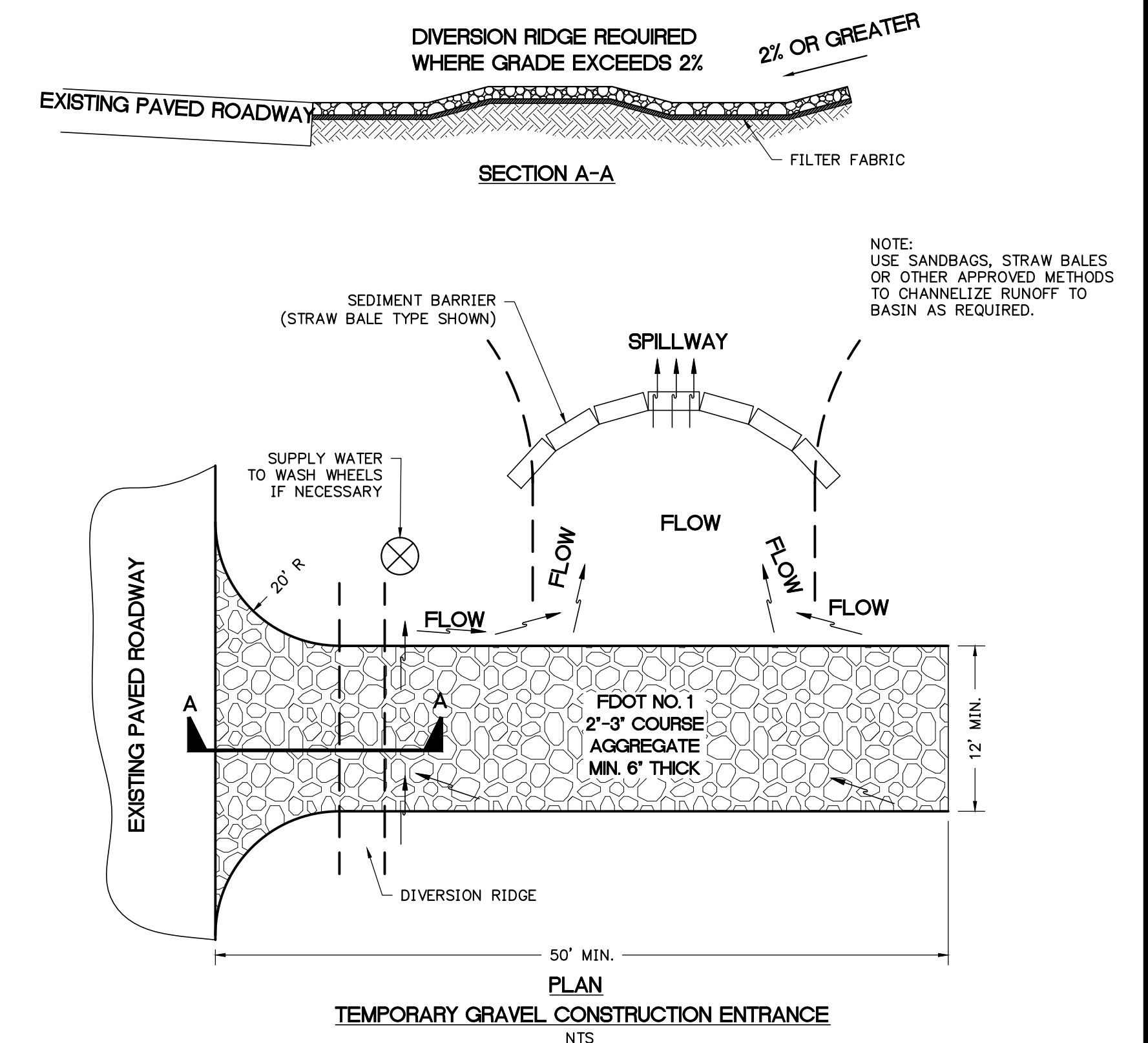

TEMPORARY GRAVEL CONSTRUCTION ENTRANCE

N.T.S.

NOTES:

1. THE ENTRANCE SHALL BE MAINTAINED IN A CONDITION THAT WILL PREVENT TRACKING OR FLOWING OF SEDIMENT ONTO PUBLIC RIGHTS-OF-WAY. THIS MAY REQUIRE TOP DRESSING, REPAIR AND/OR CLEANOUT OF ANY MEASURES USED TO TRAP SEDIMENT.
2. WHEN NECESSARY, WHEELS SHALL BE CLEANED PRIOR TO ENTRANCE ONTO PUBLIC RIGHT-OF-WAY.
3. WHEN WASHING IS REQUIRED, IT SHALL BE DONE ON AN AREA STABILIZED WITH CRUSHED STONE THAT DRAINS INTO AN APPROVED SEDIMENT TRAP OR SEDIMENT BASIN.

C:\Users\jpot\OneDrive\Documents\Civil\Projects\366-22-03 - Rib Crrib Restaurant\Drawings\22-03-01-01.dwg - 22-03-01-01.dwg - 22-03-01-01.dwg - 22-03-01-01.dwg - 22-03-01-01.dwg - 22-03-01-01.dwg - 22-03-01-01.dwg - 22-03-01-01.dwg - 22-03-01-01.dwg - 22-03-01-01.dwg

REVISIONS			
NO.	DATE	DESCRIPTION	DRWN/ APPR

ENGINEER OF RECORD: CHRISTOPHER A. POTTS, P.E. FLORIDA LICENSE NO. 73842

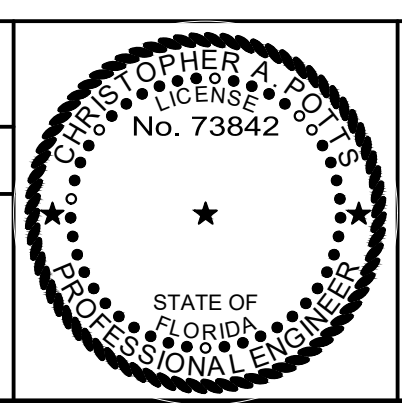

JBPro
CIVIL ENGINEERING | LAND PLANNING
SURVEYING | CONSTRUCTION SERVICES

3530 NW 43rd Street | Gainesville, Florida 32606
4420 US-1 S, Suite 1 | St. Augustine, Florida 32086
Gainesville: (352) 375-8999 | St. Augustine: (904) 789-8999
Toll Free: (844) Go-JBPro | E-mail: contact@jbpro.com

SHEET TITLE: **DETAILS AND NOTES**

DATE: **JUNE 2022**

PROJECT NO: **366-22-03**

CUSTOMER: **HIGH COTTON EQUITIES, LLC**

PROJECT: **RIB CRIB RESTAURANT LAKE CITY, FLORIDA**

SHEET NO: **C5.0**