

Tube Frame

Partial Tilt Trailer

14,000 • 16,000 • 20,000 GVW

Model	TBCT2014ET	TBCT2214ET	TBCT2016ET	TBCT2216ET	TBCT2020ET-10K	TBCT2220ET-10K
Length	20' (4' + 16')	22' (6' + 16')	20' (4' + 16')	22' (6' + 16')	20' (4' + 16')	22' (6' + 16')
Capacity	10,320 lb.	10,260 lb.	11,980 lb.	11,700 lb.	14,950 lb.	14,700 lb.
Weight	3,680 lb.	3,740 lb.	4,020 lb.	4,300 lb.	5,050 lb.	5,300 lb.
Axles	(2) 7,000 lb. Dexter Torflex		(2) 8,000 lb. Dexter Torflex		(2) 10,000 lb. Dexter Torflex	
Wheels	(4) 16 x 6 Rim, 8-on-6 1/2		(4) 17.5 x 6.75 Rim, 8-on-6 1/2		(4) 17.5 x 6.75 Rim, 8-on-6 1/2	
Tires	(4) 235-80R-16E Tire, 10-Ply		(4) 215-75R-17.5 Tire, 16-Ply		(4) 235/75R-17.5 Super Single Tire, 18-Ply	

Frame	Stationary: 8 x 2 Tube Frame	Tilt: 5 x 3 x 1/4 Angle Iron
	2' Beavertail: 1/8" Tread Plate Knife Edge Tail With Supports Every 7"	
	Front Rail: 3/16" Formed Sheet Metal 5" Above Frame	
Crossmembers	3" Channels on 12" Centers	
Jack	10,000 lb. Heavy Duty Drop Leg Jack	
Cylinder	2.5 x 8" Cushioned Cylinder	
Hitch	2 5/16 Adjustable Flat Plate Coupler or Pintle Hitch	
Tie-Downs	(4) D-Rings--(2) rear of stationary, (2) rear of tilt; Stake Pockets	
Finish	Pre-Blasted, Acid Washed, Zinc Rich Primer, Powder Coat Finish	
Electrical	Electrical Completed After Paint; DOT Approved All Sealed Rubber Mounted LED; Wiring Is Protected Through Tube Frame	
Decking	2 x 8 Treated Lumber	
Standard	True 83" Wide Between the Fenders; (4) D-Rings; Flush Deck; Pallet Fork Holders; Chain Tray; Cold Weather Wiring Harness	
Optional	Third Axle; Spare Tire and Mount; Bolt-on Toolbox; Oak Floor; Gooseneck Coupler; Winch Mount -- Bolt-on or Weld-on	

Bagley Trailer Sales
W5145 Schulz Spur Dr.
Merrill, WI 54452
715-536-9306

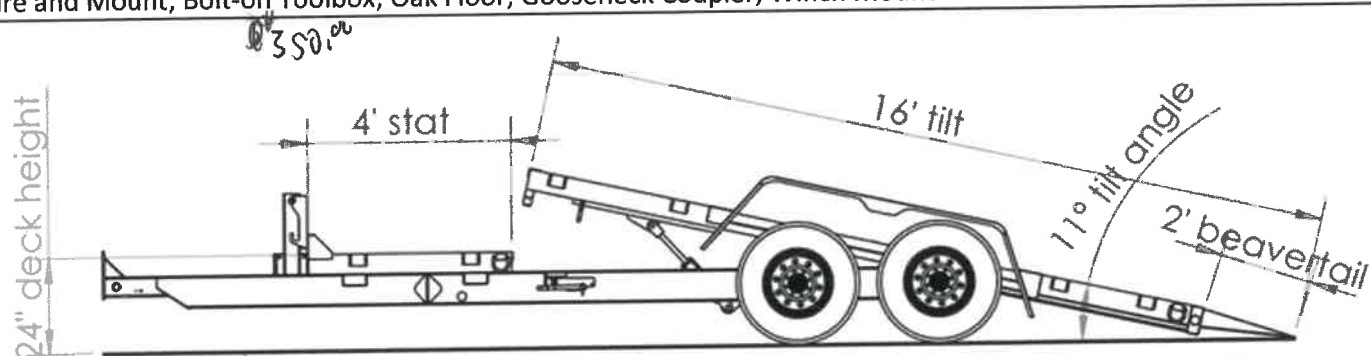

Manufactured by:
 Behnke Enterprises, Inc. ■ 800 9th Ave. NW, Farley, IA 52046 ■ Ph. (563)744-3246 ■ Fax (563)744-9066 ■ www.behnkeenterprises.com

