



City of Ketchum

April 4, 2022

Mayor Bradshaw and City Councilors
City of Ketchum
Ketchum, Idaho

Mayor Bradshaw and City Councilors:

Recommendation To Approve Agreement 22763 Between the City of Ketchum and Urban Renewal Agency

Recommendation and Summary

Staff is recommending the council authorize the Mayor to sign Agreement 22763 (Attachment A) and adopt the following motion:

I move to approve Agreement 22763 between the City of Ketchum and Ketchum Urban Renewal Agency (KURA)

The reasons for the recommendation are as follows:

- The KURA is funding the design, engineering, and construction of infill sidewalks within the Community Core.
- The proposed Agreement memorializes the roles and responsibilities between the City and KURA for the work.
- The KURA approved the agreement on February 22, 2022.

Introduction and History

The KURA is funding the design, engineering, and construction of sidewalk work in downtown Ketchum. The new sidewalks have been designed and the bid package is being prepared. The sidewalk segments are identified in Attachment B. All the segments, with the exception of the segment Q3-3, on 6th Street next to Lefty's, are included in the bid package.

The proposed agreement outlines the terms and conditions of the KURA's contribution to the project. The KURA contribution is not to exceed \$2,150,000.00 for all the work. Should the city contribute towards the project, the KURA contribution will be reduced by the amount of the city contribution.

The KURA Board approved the agreement on February 22, 2022, and recommended it be forwarded to the City Council for approval.

Sustainability

Sidewalks provide a safe and accessible walking experience. By creating a connected and consistent sidewalk network, there is less reliance on automobile use.

Financial Impact

There is no fiscal impact to the City

**PLANNING, DESIGN, ENGINEERING, AND
CONSTRUCTION PROJECT AGREEMENT
DOWNTOWN KETCHUM IMPROVEMENT PROJECT
AGREEMENT 50077 (KURA)
AGREEMENT 22763 (City)
(Phase 1 – Sidewalk Infill Project)**

THIS PLANNING, DESIGN, ENGINEERING, AND CONSTRUCTION PROJECT AGREEMENT FOR THE DOWNTOWN KETCHUM IMPROVEMENT PROJECT (PHASE 1 – SIDEWALK INFILL PROJECT) (the “Phase 1 Construction Agreement”) is made and entered into this ____ day of _____, 2022, by and between the city of Ketchum, Idaho, a municipal corporation of the state of Idaho (the “City”), and the Urban Renewal Agency of the city of Ketchum, Idaho, also known as the Ketchum Urban Renewal Agency, an independent public body corporate and politic (the “Agency”), individually referred to as “Party” and collectively as the “Parties.”

RECITALS

WHEREAS, the Agency is authorized to undertake and carry out urban renewal projects to eliminate, remedy, or prevent deteriorated or deteriorating areas through redevelopment, rehabilitation, or conservation, or any combination thereof, within its area of operation and is authorized to carry out such projects jointly with the City;

WHEREAS, the City Council, of the city of Ketchum (the “City”), by adoption of Ordinance No. 992 on November 15, 2006, duly adopted the Ketchum Urban Renewal Plan (the “2006 Plan”) to be administered by the Agency;

WHEREAS, upon the approval of Ordinance No. 1077 adopted by the City Council on November 15, 2010, and deemed effective on November 24, 2010, the Agency began implementation of the Ketchum Urban Renewal Plan 2010 (the “2010 Plan”);

WHEREAS, the 2010 Plan established the Revenue Allocation Area (the “Project Area”), which Project Area is depicted on **Exhibit A**, attached hereto, and incorporated herein by reference;

WHEREAS, the 2010 Plan identified improvement to sidewalks, streets, rights-of-way, pedestrian and bicycle access, crosswalks, and safety as important objectives of the 2010 Plan;

WHEREAS, the 2010 Plan and the Project Area terminate November 15, 2030, recognizing the Agency shall receive its allocation of revenues in 2031, pursuant to Idaho Code § 50-2903(7) (the “Termination Date”). Many of the proposed improvements identified in the 2010 Plan have not been completed and continue to suffer from certain deteriorating conditions;

WHEREAS, the City and Agency wish to engage in a series of improvements to the Downtown Ketchum area which will be executed in phases over the course of the next several years;

WHEREAS, for this first phase, the City seeks the Agency's funding of certain improvements to Downtown Ketchum including planning, design, engineering, and construction of improvements to the sidewalks, streets, and crosswalks (the "Phase 1 - Sidewalk Infill Project");

WHEREAS, preliminary estimates for the costs of the final planning, design, and engineering services are One Hundred Fifty Thousand Dollars (\$150,000.00) and construction of the Phase 1 - Sidewalk Infill Project is estimated at Two Million Dollars (\$2,000,000.00);

WHEREAS, the Agency Board finds it in the best interests of the Agency to continue to enhance the development within the Project Area and in the best interests of the public to provide financial support for the Phase 1 - Sidewalk Infill Project;

WHEREAS, the Agency and City desire that the Phase 1 – Sidewalk Infill Project be planned, designed, engineered, and constructed within the Project Area during construction season in calendar year 2022, reflecting Agency funding for FY 2022;

WHEREAS, the City has expressed its desire to participate with the Agency for the purpose of assisting in the planning, design, engineering, and constructing the Phase 1 – Sidewalk Infill Project, and providing construction management services to the Agency for the Phase 1 – Sidewalk Infill Project;

WHEREAS, the City and the Agency hereby find and determine that this Phase 1 Construction Agreement enables them to cooperate to their mutual advantage in a manner that will best accord with the needs and development of the City and the Agency;

WHEREAS, the ability for the City and Agency to cooperate and jointly benefit each other is expressly allowed pursuant to Idaho Code § 50-2015;

WHEREAS, in consideration of the payment by the Agency for the Phase 1 - Sidewalk Infill Project costs, as more specifically defined in this Phase 1 Construction Agreement, the City hereby agrees to serve and perform as project manager for the final planning, design, and engineering of the Phase 1 - Sidewalk Infill Project; said final design to be subject to the review and approval of the Agency. Additionally, the City hereby agrees to serve and perform as project manager for the construction of the Phase 1 - Sidewalk Infill Project (including the solicitation of those services) and provide project oversight and inspection;

WHEREAS, the City has committed certain funds for its contribution to the Phase 1 - Sidewalk Infill Project;

WHEREAS, the Phase 1 - Sidewalk Infill Project described in this Phase 1 Construction Agreement is part of a larger project the City is performing concerning sidewalks and improvements outside of the Project Area. The Agency will not contribute funding to improvements outside of the Project Area.

AGREEMENT

NOW, THEREFORE, in consideration of the provisions contained herein and the recital set forth above which are a material part of this Agreement the Parties agree as follows:

1. **Definitions.** As used in this Phase 1 Construction Agreement, the following words, unless the context dictates otherwise, shall have the following meanings:

Act shall mean collectively the Idaho Urban Renewal Law of 1965, title 50, chapter 20, Idaho Code, as amended and supplemented and the Local Economic Development Act of 1988, title 50, chapter 29, Idaho Code as amended and supplemented.

Board shall mean the Board of Commissioners of the Agency as the same shall be duly and regularly constituted from time to time.

Contract shall mean the contract through which the general contractor is awarded the construction of the Phase 1 – Sidewalk Infill Project.

Contractor shall mean the selected general contractor awarded the construction of the Phase 1 – Sidewalk Infill Project.

Phase 1 – Sidewalk Infill Project Engineering Services shall mean the engineering, cost estimating, surveying work, and proposing the location of certain public improvements related to the Phase 1 – Sidewalk Infill Project along with the agreement with the selected Engineering Services provider and/or as performed by the City.

Phase 1 – Sidewalk Infill Project Design shall mean the services related to planning, design, and proposing the location of the Phase 1 – Sidewalk Infill Project.

Phase 1 – Sidewalk Infill Project Installation shall mean those improvements to be constructed and installed at the Agency's expense, which improvements consist of Phase 1 – Sidewalk Infill Project within the Project Area. An illustration of the sidewalk related improvements is attached as **Exhibit B**. The City and Agency shall determine the Agency's not-to-exceed obligation amount as described in Section 6.

2. **Recitals and Purpose**

- a. The Parties agree that the foregoing recitals are not mere recitations but are covenants of the Parties, binding upon them as may be appropriate and a portion of the consideration for the agreements contained herein.
- b. The purpose of this Phase 1 Construction Agreement is to provide for the definition of rights, obligations, and responsibilities of the Agency and City regarding the planning, design services, engineering services, project management services, and cost estimating services for this Phase 1 Construction Agreement. Generally, the Agency shall be responsible for the

costs of planning, design, surveying, cost estimating, engineering, and construction of the Phase 1 - Sidewalk Infill Project, including costs for the planning, design, engineering, and administration of the Phase 1 - Sidewalk Infill Project. The City shall serve as project manager as described below. This Phase 1 Construction Agreement constitutes a joint agreement between the City and the Agency for the successful completion of the Phase 1 - Sidewalk Infill Project.

3. **City Services and Responsibilities.** City agrees to furnish its skill and judgment necessary to carry out the project administration for the Phase 1 - Sidewalk Infill Project.

3.1 Planning, Design, Engineering, and Construction. City and Agency shall coordinate hiring of necessary planning, design, engineering or landscape architectural services, cost estimating, and construction management and administration for the Phase 1 - Sidewalk Infill Project consistent with the public procurement and bidding requirements. These services include the completion of bid documents for advertising and securing construction bids for the Phase 1 - Sidewalk Infill Project. City and Agency shall jointly agree on a schedule for the completion of the bid documents. City shall provide the Agency with periodic reports and updates on the completion of the final design services, engineering services, cost estimating, and bid specifications for Agency review and comment, including approval of the final design of the Phase 1 - Sidewalk Infill Project.

3.2 Engineering Services. Agency and City acknowledge City intends to complete design and engineering services either “in house” through the City’s professional services departments or through the City’s on-call engineers, or third-party engineers. The City departments or third-party engineer will provide planning, design, engineering, site location, bid preparation, and project management for the Phase 1 - Sidewalk Infill Project. The City departments or third-party engineer will be expected to site the Phase 1 - Sidewalk Infill Project, provide the final design and engineering services for the Phase 1 - Sidewalk Infill Project, prepare the bid documents, and assist in the selection of the Contractor for the Phase 1 - Sidewalk Infill Project. In the event additional outside engineering services are needed, both City and Agency agree to proceed through the required selection process required by state statute. In that event, Agency may determine a not-to-exceed amount for such design and engineering services. Any scope of work issued to the third-part engineer shall be between the City and the engineer.

3.2.1. Planning, Site Location, Architectural Design Services, and Engineering Services. The third-party engineer or the City have completed a preliminary design concept illustrating the scale and relationship of the construction of the Phase 1 - Sidewalk Infill Project. This concept shall be the basis for the final engineering and design to be completed under this Phase 1 Construction Agreement. The completed scope of work shall include a specific cost estimate for the Phase 1 - Sidewalk Infill Project, including construction costs. If that estimate exceeds the not-to-exceed figure described in Section 6 of this Phase 1 Construction Agreement, the City and Agency shall mutually determine what alternatives should

be pursued, including redesign, relocation, seeking additional funds, limiting the scope of the Phase 1 - Sidewalk Infill Project, or not proceeding further.

3.2.2. Construction Project. Upon completion of the final planning, design, and engineering work set forth in this Phase 1 Construction Agreement, both City and Agency agree to consider moving forward with the construction of the Phase 1 - Sidewalk Infill Project. The Agency's participation or contribution to the Phase 1 - Sidewalk Infill Project shall be limited to a not-to-exceed amount as set forth in Section 6 of this Phase 1 Construction Agreement, which includes the planning, design services, engineering services, and cost estimating work described herein. Nothing herein, however, commits either the City or Agency to undertake the construction of the Phase 1 – Sidewalk Infill Project.

3.3 Bid Solicitation and Award. City, with Agency review and input as to the bid specifications, shall solicit bids (“Bid(s)”) for the Phase 1 – Sidewalk Infill Project. Representatives from Agency and City shall review the Bids at opening. The City shall designate the qualified public works contractor submitting the Bid in compliance with chapter 28, title 67, Idaho Code for the Phase 1 – Sidewalk Infill Project subject to the City's right to reject all Bids.

3.4 Design and Construction. City and Agency acknowledge the conceptual design work has commenced and final design of the Phase 1- Sidewalk Infill Project is at or near completion. The obligations under this Phase 1 Construction Agreement shall end either thirty (30) days after final payment to the Contractor under the Contract has been paid or determination by the City and Agency to not pursue the construction of the Phase 1 - Sidewalk Infill Project, whichever occurs first. The City shall:

- a. Provide administration of the Engineering Services to determine the location, design, engineering, and administration of the Phase 1 - Sidewalk Infill Project, the preparation of the bid documents for the Phase 1 - Sidewalk Infill Project and administration of the Contract.
- b. Provide administration of the Phase 1 - Sidewalk Infill Project in compliance with generally accepted standards recognizing that the Phase 1 - Sidewalk Infill Project is an Agency project with the City providing project management. City shall comply with all applicable statutory provisions including, but not limited to, chapter 28, title 67, Idaho Code;
- c. Provide necessary project management and oversight to assure Contractor's timely progress and process all invoices and payment requests and verify Contractor's entitlement to all progress payments or other payments requested by Contractor;
- d. Recommend necessary or desirable changes to the Agency and, if accepted, prepare and sign necessary change orders;

- e. Inspect the work and advise the Agency whenever work fails to conform with the Contract documents;
- f. Receive and hold all certificates of insurance required by the Contract;
- g. Provide monthly progress reports to Agency either in writing or by presentation to Agency at Agency's Board meetings;
- h. Assist in the interpretation of the drawings and specifications among the City, Agency, and the Contractor;
- i. Maintain all necessary records, documents, drawings, and other related documents normally maintained for a public works project; and
- j. Determine when the Phase 1 - Sidewalk Infill Project or a designated portion thereof is substantially complete, issue Certificates of Substantial Completion (if necessary), and determine when the work is ready for final inspection and final payment to the Contractor.
- k. The Contract for Engineering Services and with the Contractor for construction of the Phase 1 - Sidewalk Infill Project shall be between the City and the selected Contractor, and between the City and the Engineer.

3.5 City Contribution. The Phase 1 - Sidewalk Infill Project as described in this Agreement within the Project Area and funded through the Agency, is part of a larger overall improvement project to certain streets and sidewalks the City intends to pursue in 2022. The City has budgeted funds for this work. City may agree to forego reimbursement for internal costs of City personnel in performing the services described in this Agreement. City shall contribute all funds toward any work or improvements to areas outside the Project Area. In addition, any contribution by the City to costs within the Project Area shall be deducted from the amounts owing first, prior to Agency contributions.

4. **Agency and City Obligations.** The purpose of this Phase 1 Construction Agreement is to provide for the definition of rights, obligations, and responsibilities of the Agency and City regarding the construction of the Phase 1 – Sidewalk Infill Project.

5. **Effective Date.** This Phase 1 Construction Agreement shall be effective upon execution of the Phase 1 Construction Agreement by Agency's Chairman of the Board of Commissioners and the Mayor of the City and/or the City Manager, as the case may be.

6. **Method of Reimbursement.** As consideration for the City Services and Responsibilities set forth above, the Agency shall pay for the costs of the Phase 1 - Sidewalk Infill Project, including planning, design and engineering services, and project management and administration and construction by the City. Such costs are not expected to exceed Two Million One Hundred Fifty Thousand Dollars (\$2,150,000.00) including the project administration costs imposed by the City. If after the opening of the Bids, the estimated construction costs for the Phase

1 - Sidewalk Infill Project, including planning, design, and engineering costs, exceeds Two Million One Hundred Fifty Thousand Dollars (\$2,150,000.00) the City may request in writing the approval of the Agency for additional funds. Such request shall be made prior to awarding the contract and incurring any costs in excess of Two Million, One Hundred Fifty Thousand Dollars (\$2,150,000.00) Agency's funding contributions will be used only towards costs related to areas within the Project Area. All project costs related to areas outside of the Project Area will be borne by the City.

In order to provide sufficient documentation to ensure compliance, the City shall provide the Agency with the following information in monthly invoices and in a final invoice upon completion of the Phase 1 - Sidewalk Infill Project:

- a. requests for payment for billing invoices received from engineer for Engineering Services and the Contractor for work related to the Phase 1 - Sidewalk Infill Project with sufficient documentation to ensure accuracy;
- b. accounting of the Direct Personnel Expense and Reimbursable Costs (defined below);
- c. certification by the City that the costs incurred for Engineering Services and construction services are consistent with the scope of the Phase 1 - Sidewalk Infill Project; and
- d. monthly reports on the Phase 1 - Sidewalk Infill Project's status as described above.

Upon receipt and approval of the monthly invoice, Agency shall remit payment to City for all approved amounts within forty-five (45) days of Agency's receipt of an invoice or payment request. If Agency disputes any amount, Agency shall pay the undisputed amount within forty-five (45) days and reasonably cooperate with City to resolve the disputed amount. City shall include this payment process within the Contract with the selected contractor and the agreement with the selected Engineering Services firm.

City shall, upon completion of the Phase 1 - Sidewalk Infill Project, submit an invoice for all Direct Personnel Expense and Reimbursable Costs incurred by City for design, engineering, project management, and construction inspection. If Agency disputes any amount, Agency shall pay the undisputed amount within forty-five (45) days and reasonably cooperate with the City to resolve the disputed amount. The purpose of this section is to provide for payment of Phase 1 - Sidewalk Infill Project costs directly by the Agency.

Direct Personnel Expense is defined as that portion of the direct salaries of all of the City's personnel engaged on the Phase 1 - Sidewalk Infill Project and the portion of the cost of their mandatory and customary contributions and benefits related thereto such as employment taxes and other statutory employee benefits, insurance, sick leave, holidays, vacations, pensions, and similar contributions and benefits.

The term Reimbursable Costs shall mean costs necessarily incurred by the City in the proper performance of services which directly benefit the Phase 1 - Sidewalk Infill Project. Such costs shall be at rates not higher than the standard paid in Blaine County for a public works project, except as may be approved by prior consent of the Agency. City, in its sole and unilateral discretion, may decide to forego reimbursement for expenses incurred for administration of the Phase 1 - Sidewalk Infill Project as its contribution to the Phase 1 - Sidewalk Infill Project.

7. **Records of Phase 1 - Sidewalk Infill Project Costs,** Reimbursable Costs and costs pertaining to Direct Personnel Expense shall be kept on the basis of generally accepted accounting principles and shall be available to the Agency or the Agency's authorized representative at mutually convenient times.

8. **Insurance.**

- a. The City (either itself or the selected Contractor) shall purchase and maintain, for the benefit of the City and the Agency, insurance for protection from claims under the worker's compensation law of the state of Idaho arising from work performed on the Phase 1 - Sidewalk Infill Project; claims for damages because of bodily injury, including personal injury, sickness, disease, or death of any of the City's employees or of any person while working on the Phase 1 - Sidewalk Infill Project; claims for damages because of injury to or destruction or loss of use of tangible property as a result of work on the Phase 1 - Sidewalk Infill Project; and claims arising out of the performance of this Phase 1 Construction Agreement and caused by negligent acts for which the City is legally liable. The terms and limits of liability shall be determined solely by the City, and nothing herein shall be construed as any waiver of any claim or defense by the City or the Agency premised upon any claim of sovereign immunity or arising from the Idaho Tort Claims Act. The amount of insurance shall be in the amounts set forth in the Idaho Tort Claims Act.
- b. The City shall also purchase and maintain for the benefit of the City and Agency property damage insurance for any property damage to the Phase 1 - Sidewalk Infill Project or other property owned by the City.

9. **Indemnity.** Only to the extent permitted by Idaho law, the City shall defend, indemnify, and hold Agency and their respective officers, agents, and employees harmless from and against all liabilities, obligations, damages, penalties, claims, costs, charges, and expenses, including reasonable planning, design and engineering fees, and attorney fees (collectively referred to in this section as "Claim"), which may be imposed upon or incurred by or asserted against Agency or its respective officers, agents, and employees relating to the planning, design, and engineering of the Phase 1 - Sidewalk Infill Project or otherwise arising out of this Phase 1 Construction Agreement. In the event an action or proceeding is brought against Agency or their respective officers, agents, and employees by reason of any such Claim, City, upon written notice from Agency, shall, at City's expense, resist or defend such action or proceeding.

Notwithstanding the foregoing, City shall have no obligation to indemnify and hold Agency and its respective officers, agents, and employees harmless from and against any matter to the extent it arises from the negligence or willful act of Agency or its respective officers, agents, or employees or from conduct resulting in an award of punitive damages against Agency.

10. **Amendment.** This entire Phase 1 Construction Agreement may be amended at any time and from time to time by the mutual written consent of the City and the Agency.

11. **Severability.** In the event any provision of this Phase 1 Construction Agreement shall be declared by a court of competent jurisdiction to be invalid, illegal, or unenforceable, the validity, legality, and enforceability of the remaining provisions shall not in any way be affected or impaired thereby.

12. **Notice.** Any and all notices required to be given by either of the Parties hereto, unless otherwise stated in this Phase 1 Construction Agreement shall be in writing and be deemed communicated when mailed in the United States mail, certified, return receipt requested, addressed as follows:

To Agency:
Susan Scovell , Chair
Ketchum Urban Renewal Agency
P.O. Box 2315
Ketchum, ID 83340

To City:
City of Ketchum
P.O. Box 2315
Ketchum, ID 83340

13. **Non-Waiver.** Failure of either Party to exercise any of the rights under this Phase 1 Construction Agreement, or breach thereof, shall not be deemed to be a waiver of such right or a waiver of any subsequent breach.

14. **Choice of Law.** Any dispute under this Phase 1 Construction Agreement, or related to this Phase 1 Construction Agreement, shall be decided in accordance with the laws of the state of Idaho.

15. **Attorney Fees.** Should any litigation be commenced between the Parties hereto concerning this Phase 1 Construction Agreement, the prevailing Party shall be entitled, in addition to any other relief as may be granted, to costs and reasonable attorneys' fees as determined by a court or arbitrator of competent jurisdiction. This provision shall be deemed to be a separate contract between the Parties and shall survive any default, termination, or forfeiture of this Phase 1 Construction Agreement.

16. **Authority to Execute.** Agency and City have duly authorized and have full power and authority to execute this Phase 1 Construction Agreement.

17. **Assignment.** It is expressly agreed and understood by the Parties hereto that the City shall not have the right to assign, transfer, hypothecate, or sell any of its rights under this Phase 1 Construction Agreement except upon the prior express written consent of Agency.

18. **Disputes.** In the event that a dispute arises between Agency and City regarding application or interpretation of any provision of this Phase 1 Construction Agreement, the aggrieved Party shall promptly notify the other Party to this Phase 1 Construction Agreement of the dispute within ten (10) days after such dispute arises. If the Parties shall have failed to resolve the dispute within thirty (30) days after delivery of such notice, each Party shall have the right to pursue any rights or remedies it may have at law or in equity.

19. **Entire Agreement.** This Phase 1 Construction Agreement along with any and all exhibits attached hereto and incorporated herein by reference contains and integrates all of the terms and conditions mentioned herein or incidental hereto and supersedes all negotiations or previous agreements between the Parties with respect to all or any part of the Project.

IN WITNESS WHEREOF, the Parties hereto, through their respective governing boards, have executed this Phase 1 Construction Agreement on the date first cited above.

CITY OF KETCHUM

By _____
Neil Bradshaw, Mayor

ATTEST:

City Clerk

KETCHUM URBAN RENEWAL AGENCY

By _____
Susan Scovell, Chair

ATTEST:

Secretary

Exhibit A

(Project Area Map)

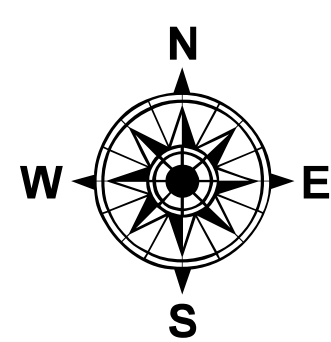
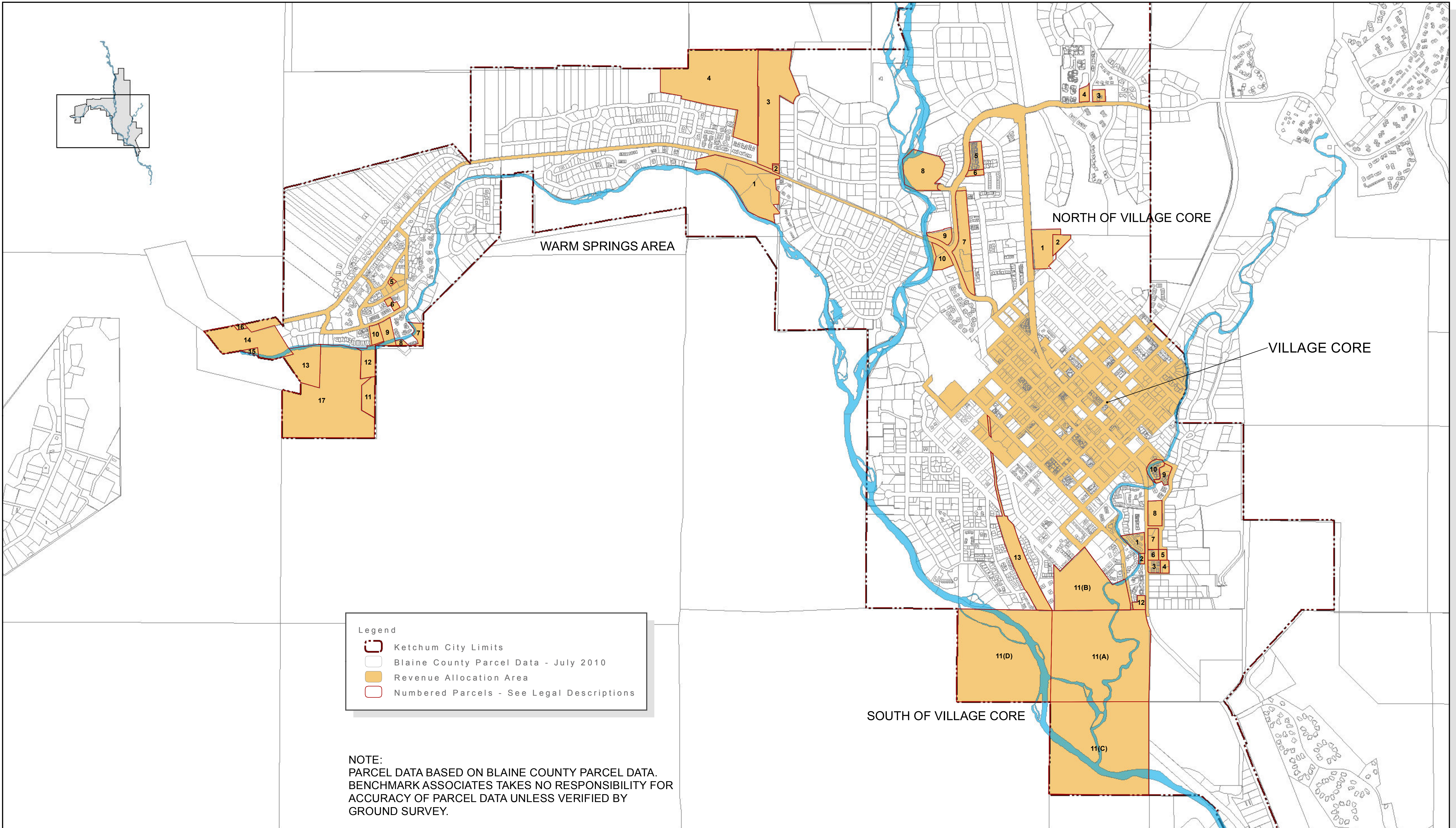

MAP DATE: 10/04/2010
 Produced by BMA-JEL
 FILE: K-URA_10.23.06.mxd

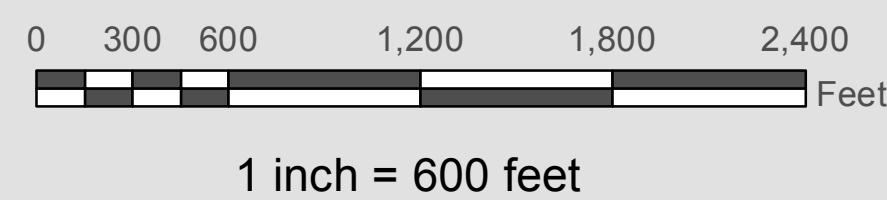

KETCHUM URBAN RENEWAL AGENCY
REVENUE ALLOCATION AREA
FINAL - OCTOBER 2010

Benchmark Associates P.A.
 P.O. Box 733 - 100 Bell Drive
 Ketchum, ID 83340
 (208) 726-9512
 © copyright 2006



Exhibit B

(Illustration of the Phase 1 - Sidewalk Infill)

4872-0600-1162, v. 3

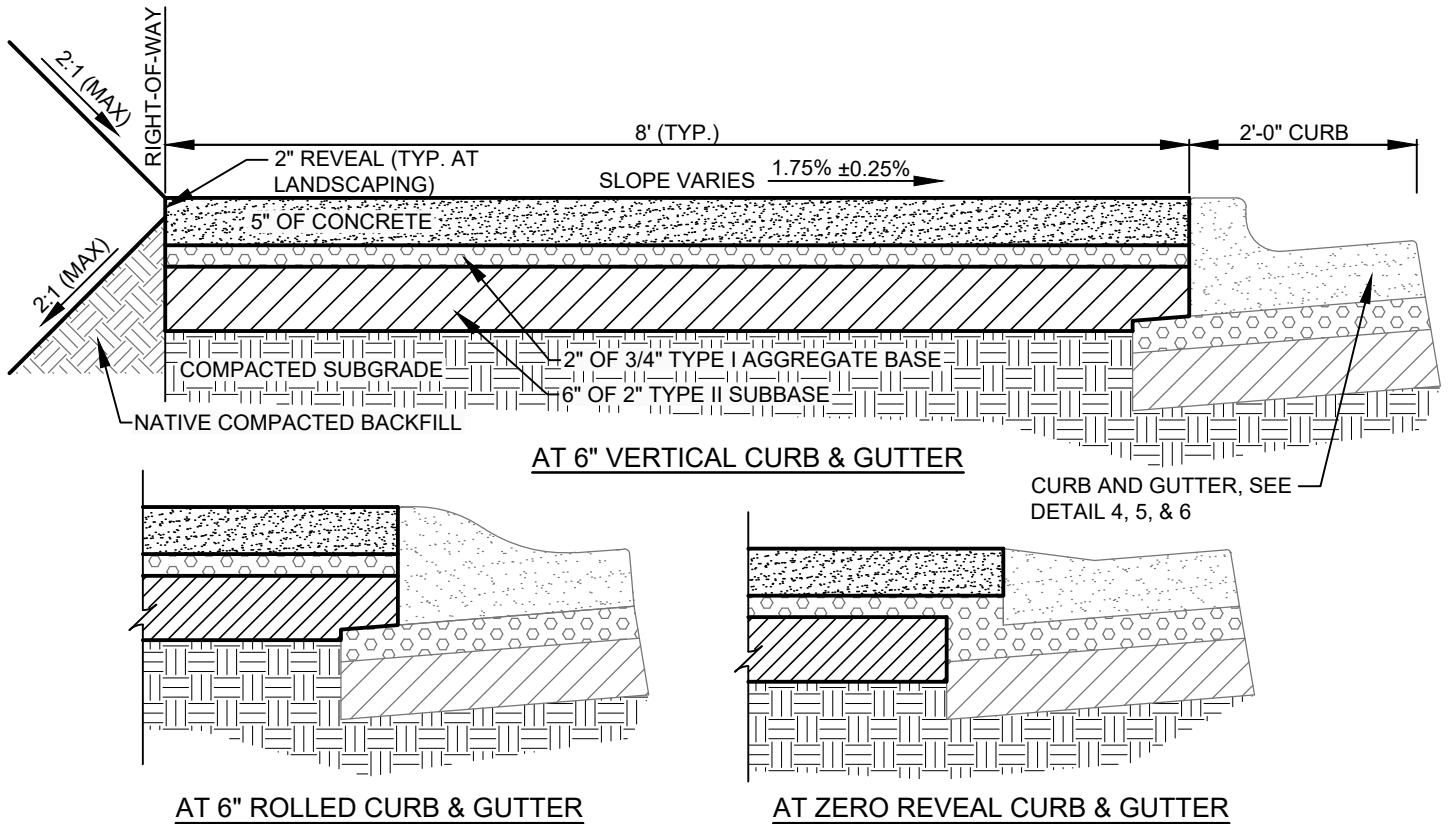

CONCRETE SIDEWALK WITH CURB AND GUTTER

NOTES:

1. INSTALL SCORE JOINTS AT INTERVALS TO MATCH WIDTH OF WALK NOT TO EXCEED 5 FEET SPACING IN BOTH THE LONGITUDINAL AND TRANSVERSE DIRECTION FOR SIDEWALK GREATER THAN 5 FEET IN WIDTH. INSTALL EXPANSION JOINTS EVERY 10 FEET IN LONGITUDINAL DIRECTION.
2. 1/2" TRANSVERSE PREFORMED BITUMINOUS JOINTS AT THE TERMINUS POINTS FOR CURVE AND WHERE SIDEWALK IS PLACED BETWEEN TWO PERMANENT FOUNDATIONS OR ADJACENT TO THE STRUCTURE, PLACE 1/2" EXPANSION JOINT MATERIAL ALONG THE BACK OF WALK THE FULL LENGTH.
3. SIDEWALK CONSTRUCTION JOINTS SHALL BE CONSTRUCTED APPROXIMATELY 1/8" WIDE, 3/4" IN DEPTH AND FINISHED AND EDGED SMOOTH. A PREFORMED EXPANSION JOINT FILLER SHALL BE PLACED EVERY 40' FOR NEW SIDEWALK CONSTRUCTION.
4. WHEN TRANSITIONING NEW SIDEWALK TO EXISTING, A MINIMUM 5' TRANSITIONAL PANEL SHALL BE SEPARATED AND ISOLATED WITH EXPANSION MATERIAL.
5. SIDEWALK ALIGNMENT TRANSITIONS SHALL HAVE A MINIMUM RADIUS OF 30' TO THE FACE OF CURB.
6. MATERIALS SHALL CONFORM WITH CURRENT ISPCW STANDARDS, DIVISION 800 AGGREGATES AND ASPHALT.

REVISION	APPROVED	DATE	CITY OF KETCHUM STANDARD DRAWING	DRAWING NO.
REV. 1	CITY	10/2019	CONCRETE SIDEWALK WITH CURB AND GUTTER	7

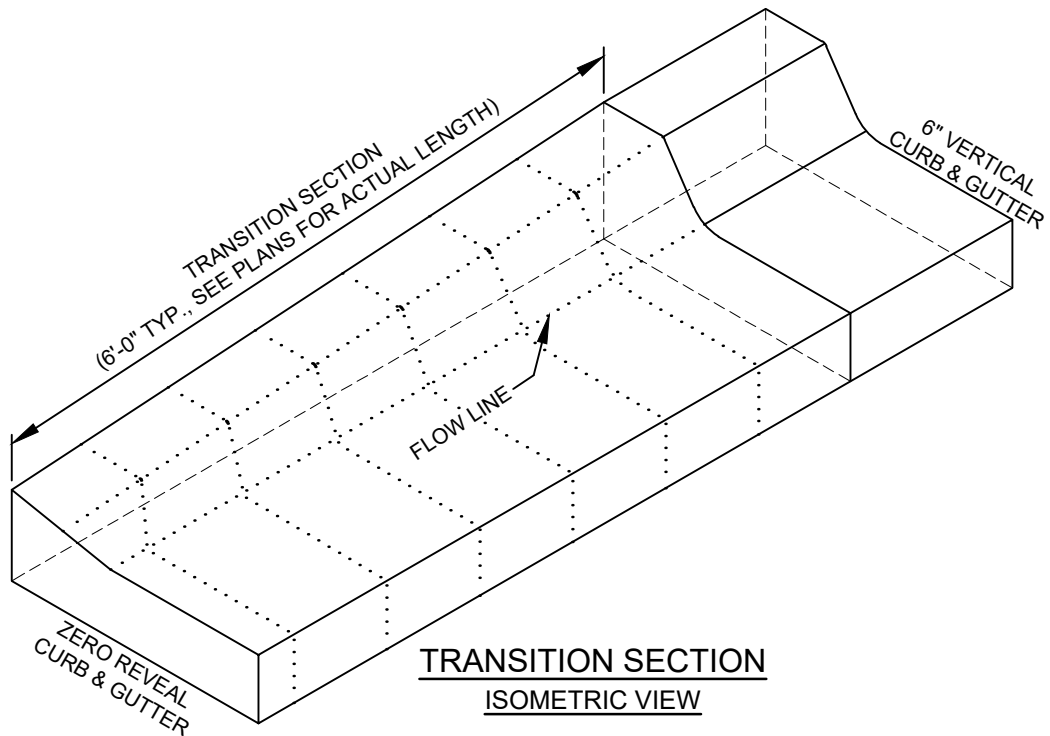

**TRANSITION SECTION
ISOMETRIC VIEW**

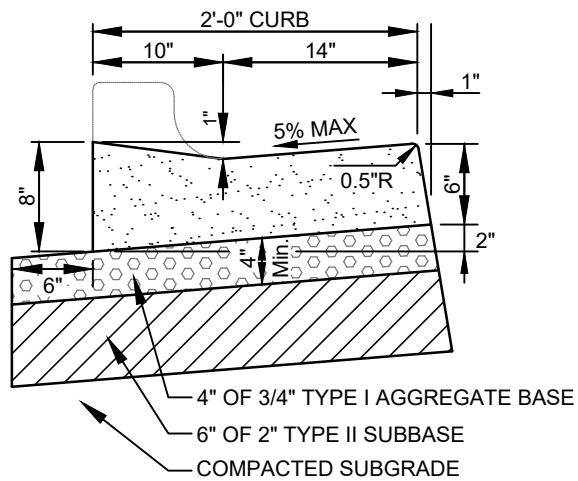

ZERO REVEAL CURB & GUTTER

NOTES:

1. 1/2-INCH PREFORMED EXPANSION JOINT MATERIAL (AASHTO M 213) AT TERMINAL POINTS OF RADII.
2. CONTINUOUS PLACEMENT PREFERRED, SCORE INTERVALS TO MATCH SIDEWALK WITH 10-FOOT MAXIMUM SPACING.
2. MATERIALS SHALL CONFORM WITH CURRENT ISPWC STANDARDS, DIVISION 800 AGGREGATES AND ASPHALT.

REVISION	APPROVED	DATE
REV. 1	CITY	10/2019

CITY OF KETCHUM STANDARD DRAWING

**TYPICAL CURB
TRANSITION DETAIL**

DRAWING NO. **6**

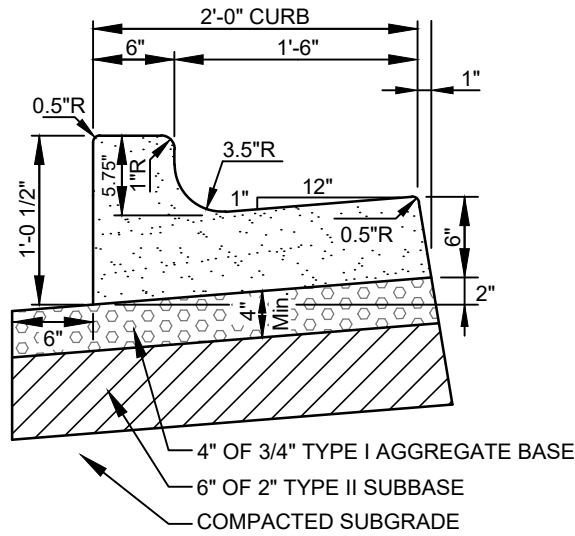

6" CONCRETE VERTICAL CURB & GUTTER

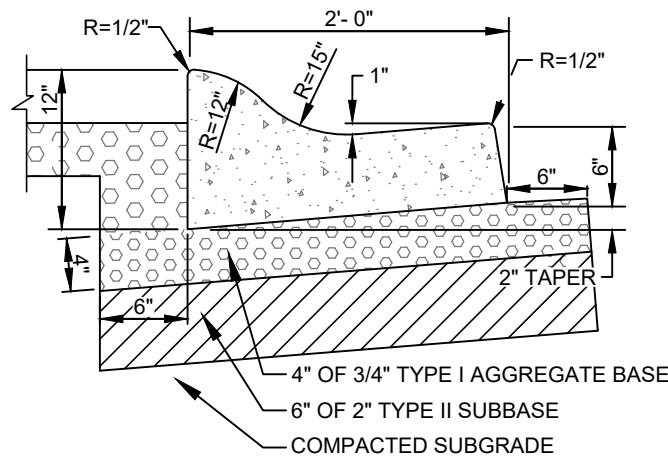

6" CONCRETE ROLLED CURB & GUTTER 3" ROLLED CURB NOT PERMITTED

NOTES:

1. 1/2-INCH PREFORMED EXPANSION JOINT MATERIAL (AASHTO M 213) AT TERMINAL POINTS OF RADII.
2. CONTINUOUS PLACEMENT PREFERRED, SCORE INTERVALS TO MATCH SIDEWALK WITH 10-FOOT MAXIMUM SPACING.
2. MATERIALS SHALL CONFORM WITH CURRENT ISPWC STANDARDS, DIVISION 800 AGGREGATES AND ASPHALT.

REVISION	APPROVED	DATE	CITY OF KETCHUM STANDARD DRAWING	DRAWING NO.
REV. 1	CITY	10/2019		

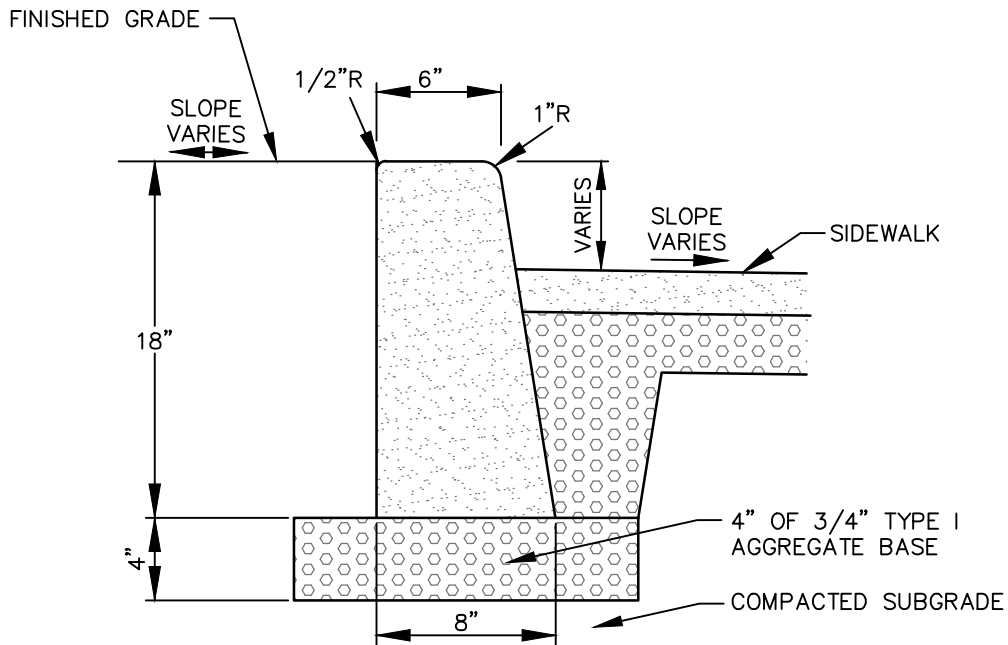

6" CONCRETE VERTICAL CURB

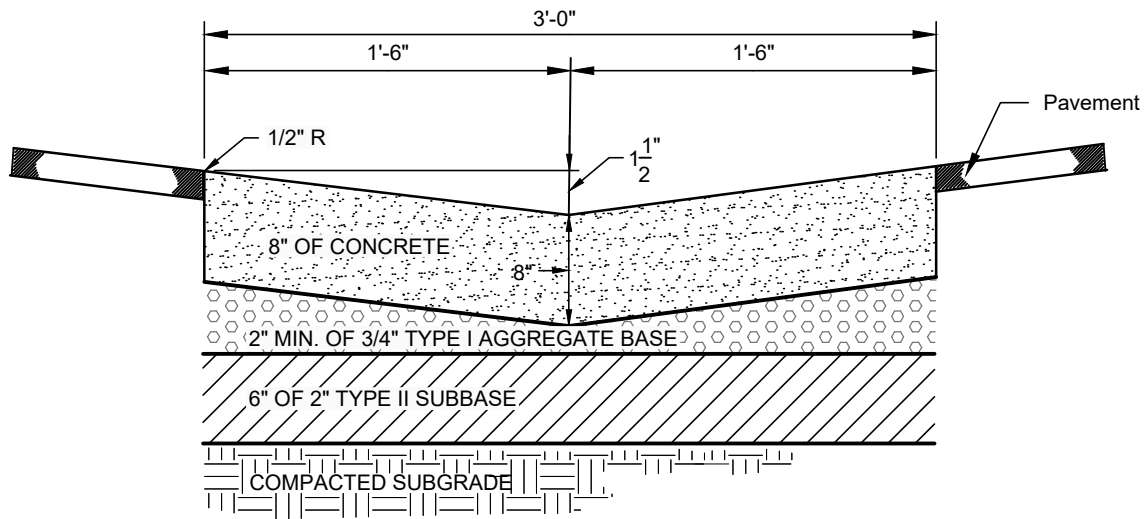

36" CONCRETE VALLEY GUTTER

NOTES:

1. 1/2-INCH PREFORMED EXPANSION JOINT MATERIAL (AASHTO M 213) AT TERMINAL POINTS OF RADII.
2. CONTINUOUS PLACEMENT PREFERRED, SCORE INTERVALS TO MATCH SIDEWALK WITH 10-FEET MAXIMUM SPACING.
2. MATERIALS SHALL CONFORM WITH CURRENT ISPWC STANDARDS, DIVISION 800 AGGREGATES AND ASPHALT.

REVISION	APPROVED	DATE	CITY OF KETCHUM STANDARD DRAWING	DRAWING NO.
REV. 1	CITY	10/2019	TYPICAL CURB & GUTTER	5

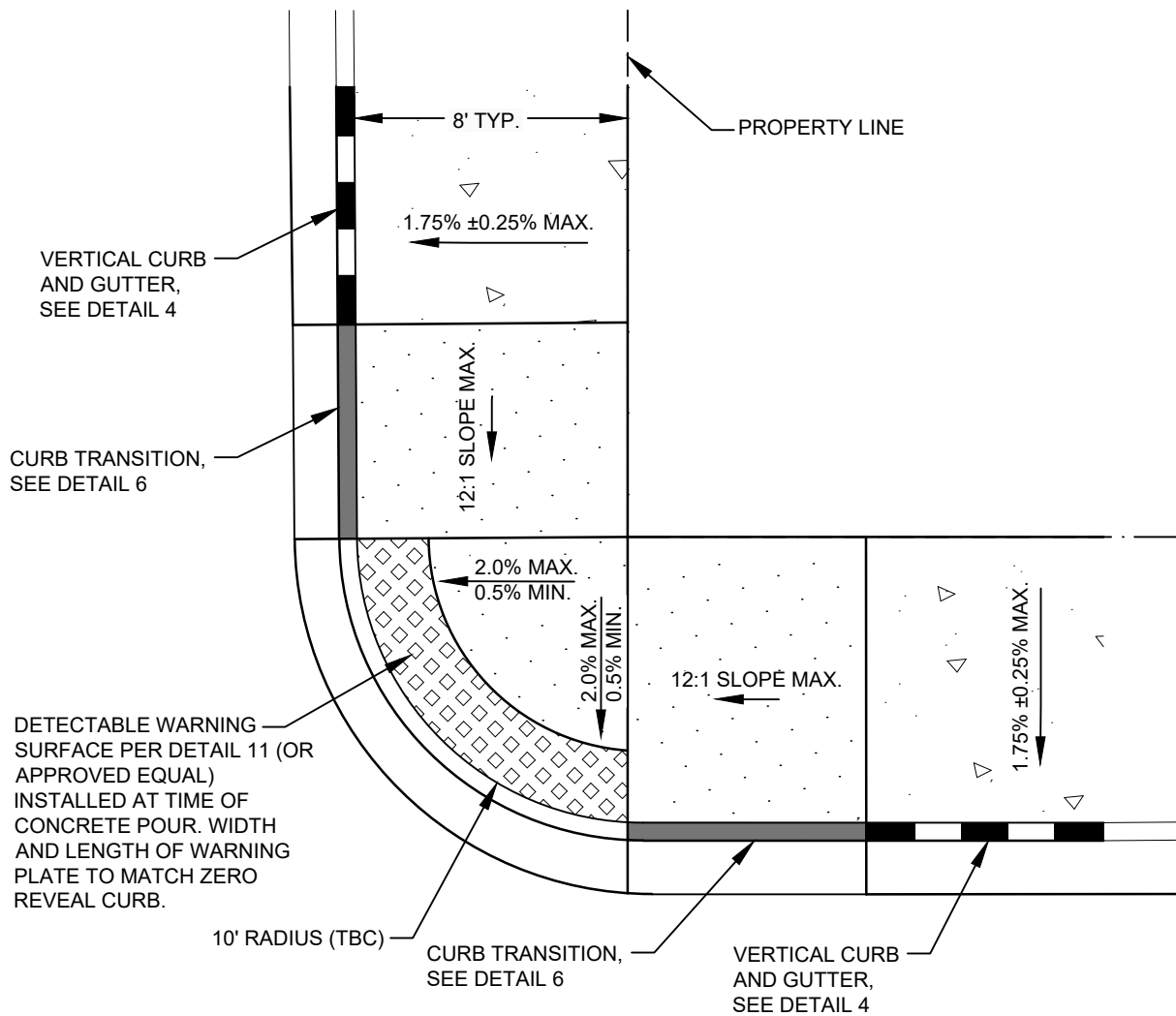

NOTES:

1. RAMP CONFIGURATION SHOWN HEREON IS PREFERRED. CITY MAY APPROVE ALTERNATE CONFIGURATIONS IF SITE RESTRICTIONS EXIST.
2. ALTERNATE RAMPS MUST CONFORM WITH CURRENT ISPWC PEDESTRIAN RAMP STANDARD DRAWING 712.

REVISION	APPROVED	DATE
REV. 1	CITY	10/2019

CITY OF KETCHUM STANDARD DRAWING

DRAWING NO.

ADA RAMP DETAIL

8

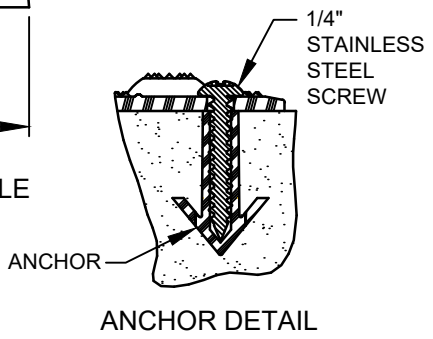
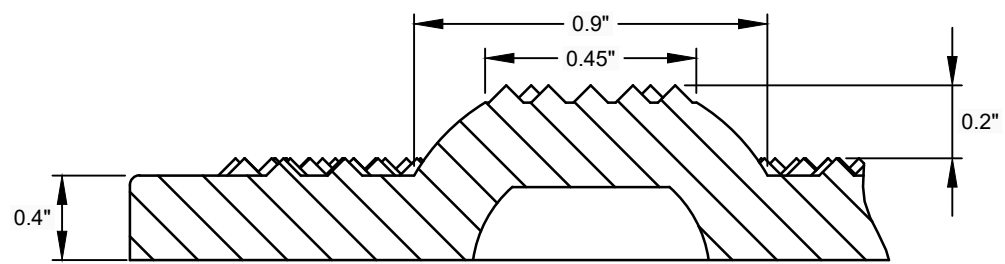
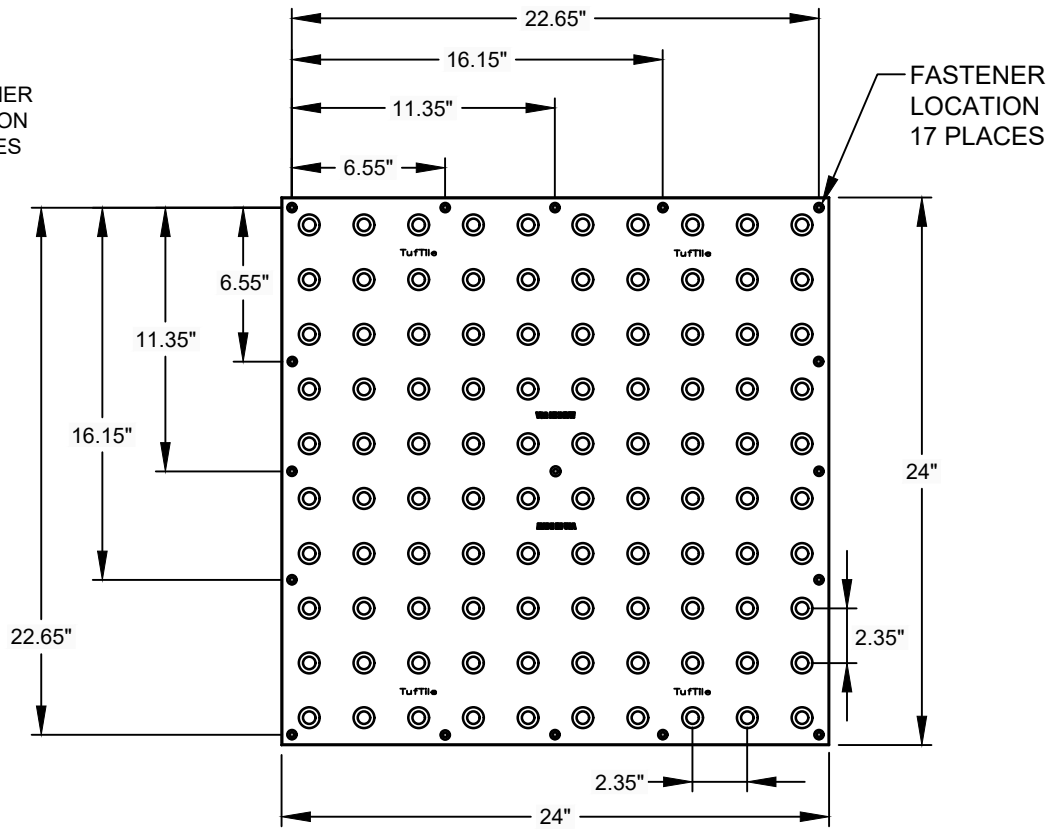
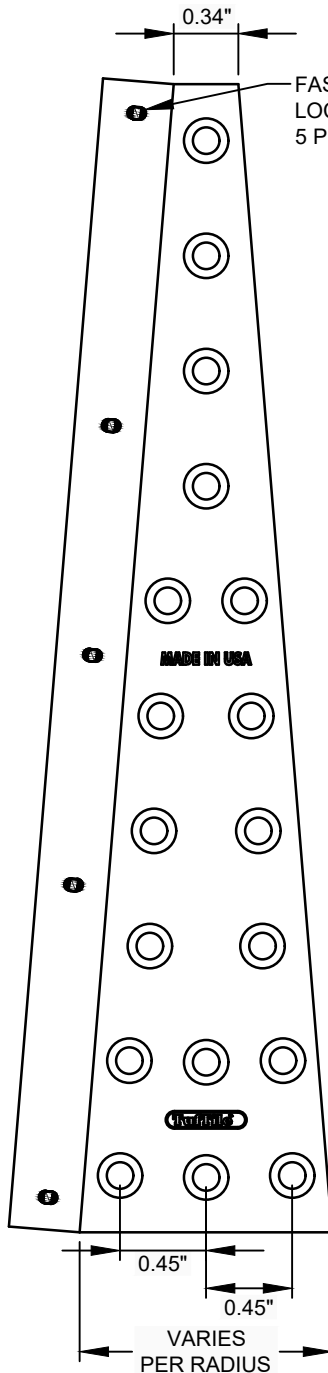

- NOTES:**
1. DETECTABLE WARNING TILES SHALL BE TUFTILE (CAST IRON & WET SET) OR APPROVED EQUAL.
 2. REFER TO DETAIL 8.
 3. COLOR TO BE PATINA (NO FINISH).

REVISION	APPROVED	DATE
REV. 1	CITY	10/2019

CITY OF KETCHUM STANDARD DRAWING

DETECTABLE WARNING PLATE

DRAWING NO.

9

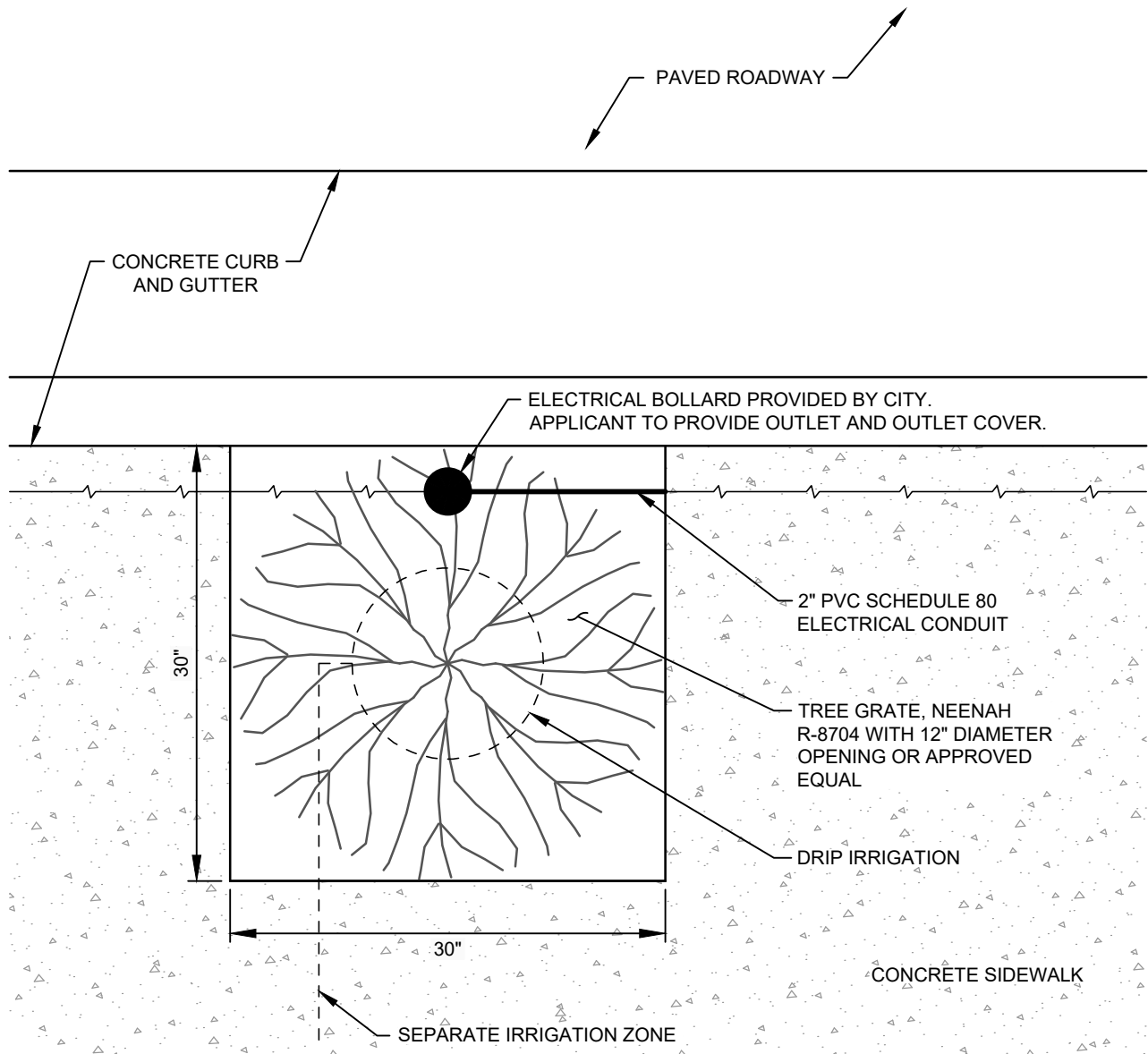

NOTES:

1. TREE TO BE 3" MINIMUM CALIPER AUTUMN BLAZE MAPLE OR APPROVED EQUAL.
2. CITY OF KETCHUM REQUIRES DRIP IRRIGATION TO BE ON A SEPARATE ZONE WITH HUNTER/RAINWISE SMART CLOCK, OR APPROVED EQUAL, FOR REMOTE ACCESS BY CITY.
3. APPLICANT TO CONNECT AND PROVIDE CONDUITS, WIRING, AND SEPARATE CIRCUIT, OR TIE TO A CITY CIRCUIT FOR POWER.
4. NO DIRECT BURIAL WIRE PERMITTED.
5. TREE INSTALLATION TO BE MODULAR SUSPENDED PAVEMENT SYSTEM. SEE TREE WELL SECTION VIEW, DETAIL 2.

PLAN VIEW

REVISION	APPROVED	DATE	CITY OF KETCHUM STANDARD DRAWING	DRAWING NO.
REV. 1	CITY	10/2019		TREE WELL DETAIL

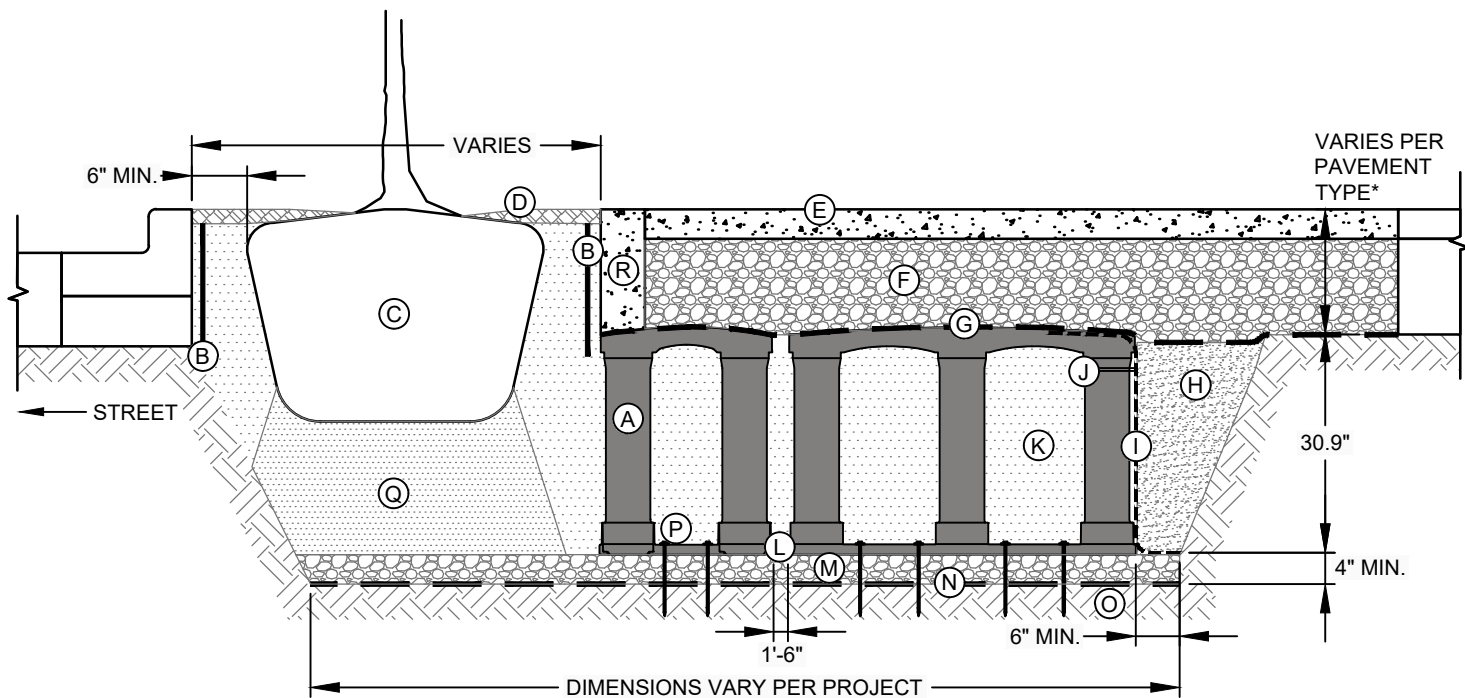

MODULAR SUSPENDED PAVEMENT SYSTEM

KEY PLAN:

- A. SILVA CELL SYSTEM (DECK, BASE, AND POSTS) OR APPROVED EQUAL.
- B. DEEPROOT ROOT BARRIER, 12" OR 18", DEPTH DETERMINED BY THICKNESS OF PAVEMENT SECTION, INSTALL DIRECTLY ADJACENT TO CONCRETE EDGE RESTRAINT. PREVENTS ROOTS FROM DISTURBING PAVEMENT.
- C. TREE ROOT PACKAGE, SIZE VARIES
- D. TREE OPENING TREATMENT, PER PROJECT SPECIFICATIONS
- E. SURFACE TREATMENT, PER PROJECT
- F. AGGREGATE BASE COURSE, DEPTH VARIES PER PROJECT
- G. GEOTEXTILE TO KEEP AGGREGATE FROM MIGRATING DOWN THROUGH CELL DECK
- H. BACKFILL, PER PROJECT SPECIFICATIONS
- I. GEOGRID TO PROVIDE FOR VERTICAL SEPARATION BETWEEN PLANTING SOILS AND BACKFILL WHILE ALLOWING ROOT PENETRATION INTO ADJACENT SOILS. 6" (150 mm) TOE (OUTWARD FROM BASE) AND 12" (305 mm) EXCESS (OVER TOP OF DECK).
- J. CABLE TIE, ATTACHING GEOGRID TO SILVA CELL AT BASE OF UPPER POST FLARE
- K. PLANTING SOIL, PER PROJECT SPECIFICATIONS, COMPACTED TO 70-80% PROCTOR
- L. SILVA CELL BASE SLOPE, 10% MAX
- M. 4" (100 mm) MIN AGGREGATE SUB BASE, COMPACTED TO 95% PROCTOR
- N. GEOTEXTILE, TO PROVIDE SEPARATION BETWEEN SUBGRADE AND AGGREGATE BASE
- O. SUBGRADE, COMPACTED TO 95% PROCTOR
- P. PIN, PER SILVA CELL SPECIFICATIONS, TO KEEP CELLS IN PLACE DURING CONSTRUCTION
- Q. PLANTING SOIL BELOW TREE ROOT PACKAGE, COMPACTED TO 85-90% PROCTOR
- R. CONCRETE EDGE RESTRAINT TO STABILIZE EDGE AND PREVENT AGGREGATE MIGRATION INTO TREE OPENING.

*MINIMUM PAVEMENT PROFILE OPTIONS TO MEET H-20 LOADING	
PAVEMENT	+ AGGREGATE BASE COURSE
4" CONCRETE	+ 4" AGGREGATE
3" PAVER	+ 12" AGGREGATE
4" ASPHALT	+ 12" AGGREGATE
2.6" PAVER	+ 5" CONCRETE

SECTION VIEW

NOTES:

1. EXCAVATION SHALL BE DONE IN ACCORDANCE WITH ALL APPLICABLE HEALTH AND SAFETY REGULATIONS.
2. INSTALLATION TO BE COMPLETED IN ACCORDANCE WITH MANUFACTURER'S SPECIFICATIONS.
3. A PROJECT SPECIFIC DETAIL WILL NEED TO BE PROVIDED TO CITY FOR REVIEW AND APPROVAL.

REVISION	APPROVED	DATE	CITY OF KETCHUM STANDARD DRAWING	DRAWING NO.
REV. 1	CITY	10/2019		
			TREE WELL DETAIL	2

