



STAFF REPORT
KETCHUM HISTORIC PRESERVATION COMMISSION
REGULAR MEETING OF JULY 7, 2026

PROJECT: Goldmine Historic Alteration

FILE NUMBER: 26-KET-00159

APPLICATION: Historic Alteration

REPRESENTATIVE: The Community Library

PROPERTY OWNER: The Community Library

LOCATION: 331 Walnut Ave

ZONING: Community Core Subdistrict 1 - Retail Core (CC-1)

REVIEWER: Genoa Beiser, Associate Planner

NOTICE: A public hearing notice for the project was mailed to all owners of property within 300 feet of the project site, mailed to all political subdivisions, and published in the Idaho Mountain Express on June 17, 2026. A public hearing notice was posted on the city website on June 22, 2026. A public hearing notice was posted on the project site on June 29, 2026.

EXECUTIVE SUMMARY

The Community Library submitted an application for a Historic Alteration at 331 Walnut Avenue (subject property), commonly known as the Gold Mine. The project proposes installing a centerline, 3-foot grated system on a portion of the northwest wall of the building and a fence like art feature extending from the northwest wall towards Walnut Avenue (see Figure 1 on Page 2). The grated system will provide a base for informational timeline plaques that are one part of the Community Library's Winter Sports Hall of Fame project. The proposal will be installed in the exterior walkway between the Gold Mine and the neighboring building at 580 E 4th Street (The Carr Building), where the Wood River Museum of History and Culture is currently located.



Figure 1: Proposal for the NW wall of the Gold Mine. See more details in Attachment A: Application Materials.

BACKGROUND

After multiple staff meetings prior to application submittal, the Planning and Building Department received the Historic Alteration application on June 6, 2026. Following receipt, staff conducted one round of review and confirmed that staff comments were addressed through subsequent discussions with the applicant. The application was then scheduled for a public hearing.

ANALYSIS

Staff reviewed the Historic Alteration for conformance with Ketchum Municipal Code (KMC) 16.07.060.D. In reviewing a request for alteration of a historic structure, the Historic Preservation Commission (HPC) shall determine if the application complies with the following review criteria:

- a. The proposed work preserves, enhances or restores and does not damage or destroy the exterior architectural features of the historic structure;
- b. The historic property remains recognizable as a physical record of its time and place. The alteration will not create a false sense of historical development by adding conjectural features or elements from other historic properties or time periods;
- c. Changes to the property that have acquired historic significance in their own right are retained and preserved to the extent possible; and
- d. In the case of partial demolition, the applicant must establish that the partial demolition is required for the renovation, restoration, or rehabilitation of the structure.

After review by staff, the project was found to satisfy the above criteria for Historic Alterations. The staff analysis below evaluates the proposal against the four criteria.

Criteria a.

The proposed work preserves, enhances or restores and does not damage or destroy the exterior architectural features of the historic structure

The subject property was donated by Union Pacific in 1955 to provide a site for the construction of a privately funded public library. In 1957, The Community Library opened its doors with a library in the front and the Gold Mine in the back. While the proposed cultural exhibition design does not speak directly to the building, staff feel the overall nature of celebrating our valley's winter sports legacy reinforces the original role of the building as a place to connect and seek knowledge. The scope of this project is minimal in nature and does not alter exterior architectural features. As the applicant aptly describes, the building's design, shape, materiality, rhythm, and public perception



Figure 2: Exhibition view from the alley way entrance

are retained. As a whole, staff feel the installation works to enhance the legacy of this historical building.

The gridded system comprising the main component of the installation under review is designed to minimize the amount of installation points for the timeline plaques. The system would be installed using fasteners into the mortar and connected to wood joints/framing whenever possible.

Initially, staff had concerns about this proposal and whether it would be strong enough to hold the weight of the metal grid system and phenolic resin plaques without deteriorating the mortar. Staff consulted with the State Historic Preservation Office (SHPO) who concurred and suggested that other supports be added from above or below. However, SPHO also stated that if other options were not viable, the best option is to install fasteners into the mortar and not directly into

the brick. The applicant still intends to have some points of contact installed into the mortar but has been exploring additional means of support with their contractor, not attached to the building, along with discussions about using a different material for the plaques to reduce the weight of the installation.

Staff feel The Community Library has been working diligently to find a solution for connecting the gridded system. As both the applicant and longtime steward & owner of the property, The Community Library has a vested interest in maintaining the integrity of the façade along with making sure the exhibition is secure for visitors. Zooming out, staff feel that the general proposal conforms with the criteria to not damage or destroy the exterior architectural features of the building. This criteria covers projects with wildly varying scopes so while there are some minor details to be solidified, the intent is met.

If the Commission disagrees, staff suggest that a condition be considered detailing that the applicant continue to work with staff (who will consult with SHPO as needed) to approve of the final installation solution.

Criteria b.

The historic property remains recognizable as a physical record of its time and place. The alteration will not create a false sense of historical development by adding conjectural features or elements from other historic properties or time periods.

The scope of this project is minimal in nature. The proposal does not alter the subject property as to obscure time and place. While the proposal is not of the building's time period, the alteration is an exhibition/art installation verses an addition and designed to be removable. It does not include features or elements that create a



Figure 3: Gold Mine circa 1957

false sense of history regarding the building as a whole. In fact, due to the topic of the installation (Sun Valley winter sports history), the proposal brings a greater appreciation of and engagement with the buildings' historic place in Ketchum.

Criteria c.

Changes to the property that have acquired historic significance in their own right are retained and preserved to the extent possible.

The applicant is not proposing significant changes to the building - only minor additions to an unadorned, exterior brick wall situated towards an interior side lot line. Historically significant features are retained and preserved without adjustments.

Criteria d.

In the case of partial demolition, the applicant must establish that the partial demolition is required for the renovation, restoration, or rehabilitation of the structure.

The applicant is not proposing any demolition of the building. Staff find this criteria is not applicable.

While not explicitly in the review criteria and therefore not under purview of staff or the Commission to review under this application, staff wants to highlight that there is a lighting feature proposed. An Administrative Design Review will be required for the remaining components of the Sun Valley Winter Sports Hall of Fame. Staff has added a condition to reinforce that the lighting feature will be reviewed for Dark Sky Compliance through that future application.

STAFF RECOMMENDATION

The Commission has the following options for the Historic Alteration application:

- Continue the application, to a date certain or uncertain, with a request for revisions or more information.
- Approval
- Approval with conditions

- Denial

Staff recommend the Commission review the Historic Alteration Application (File No. 26-KET-00159) for the Goldmine Historic Alteration and **approve** the application with the conditions outlined below. The Commission may delete, revise, or add to the conditions based on the discussion.

1. The applicant shall submit an Administrative Design Review under which the lighting feature in Historic Alteration application 26-KET-00159 shall be reviewed for Dark Sky compliance.

ATTACHMENTS:

- A. Application Materials



City of Ketchum

ATTACHMENT A

Application Materials

Narrative – Alterations

- a. The proposed work preserves, enhances or restores and does not damage or destroy the exterior architectural features of the historic structure:**

The Community Library aims to honor the historic Gold Mine building while celebrating the legacy of winter sports that has shaped the character of Ketchum, Sun Valley, and the Wood River Valley for nearly a century. The Community Library's Sun Valley Winter Sports Hall of Fame commemorates stories of individual achievement and collective effort in the winter sports arena. The outdoor cultural exhibit will highlight history in the heart of downtown Ketchum, alongside one of the most beloved historical institutions in town. We hope that locals and visitors alike will feel a sense of place, civic pride, and inspiration when they stroll this cultural exhibit to get a glimpse into the valley's rich winter sports history and the remarkable stories that shaped it.

The proposed work does not alter the exterior architectural features of the Gold Mine building. The project does not change the building's design, shape, materiality, rhythm, or public perception. It does not alter how the structure sits within the downtown urban fabric. In fact, we hope that, by drawing residents and visitors through the pedestrian passageway, the project will enhance public appreciation of the building's masonry pattern, scale, construction, and overall presence.

The main exhibit structure is designed to minimize impact on the building by using a grid with minimal attachment points. All or nearly all exhibit will be installed using fasteners placed in mortar joints or connected to existing wood joists and framing wherever possible, minimizing impacts to historic brick and limiting the size and number of attachment points while maintaining the integrity of the exhibit and visitor safety.

- b. The historic property remains recognizable as a physical record of its time and place. The alteration will not create a false sense of historical development by adding conjectural features or elements from other historic properties or time periods:**

We want people to notice the historic nature of the Gold Mine! The proposed alterations will allow the historic property to remain clearly recognizable as a physical record of its time and place. The project does not introduce conjectural

architectural features, replica historic elements, or design components drawn from other historic properties or time periods. Rather, the exhibit elements are contemporary, interpretive additions that are clearly distinguishable from the original historic structure and do not alter the building's fundamental character, form, materiality, or historic presence within the downtown streetscape. Because the installations are designed to be removable and will be attached in a minimally invasive manner, the integrity and authenticity of the historic building will remain intact while enhancing public engagement with the site and its history.

c. Changes to the property that have acquired historic significance in their own right are retained and preserved to the extent possible:

The proposed project retains and preserves the existing character-defining features of the historic property, including those changes and materials that have acquired significance over time. The project does not alter the building's established form.

d. In the case of partial demolition, the applicant must establish that the partial demolition is required for the renovation, restoration, or rehabilitation of the structure:

The current building will remain fully intact. There is no demolition.

EXHIBIT LOCATION PLAN

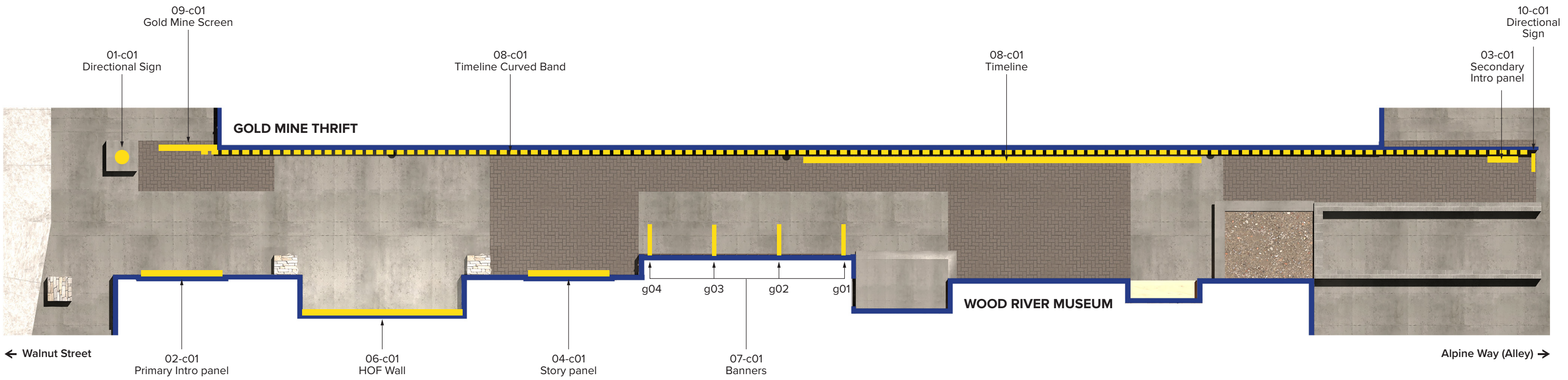

1 EXHIBIT LOCATION PLAN
NTS



08-C01: TIMELINE

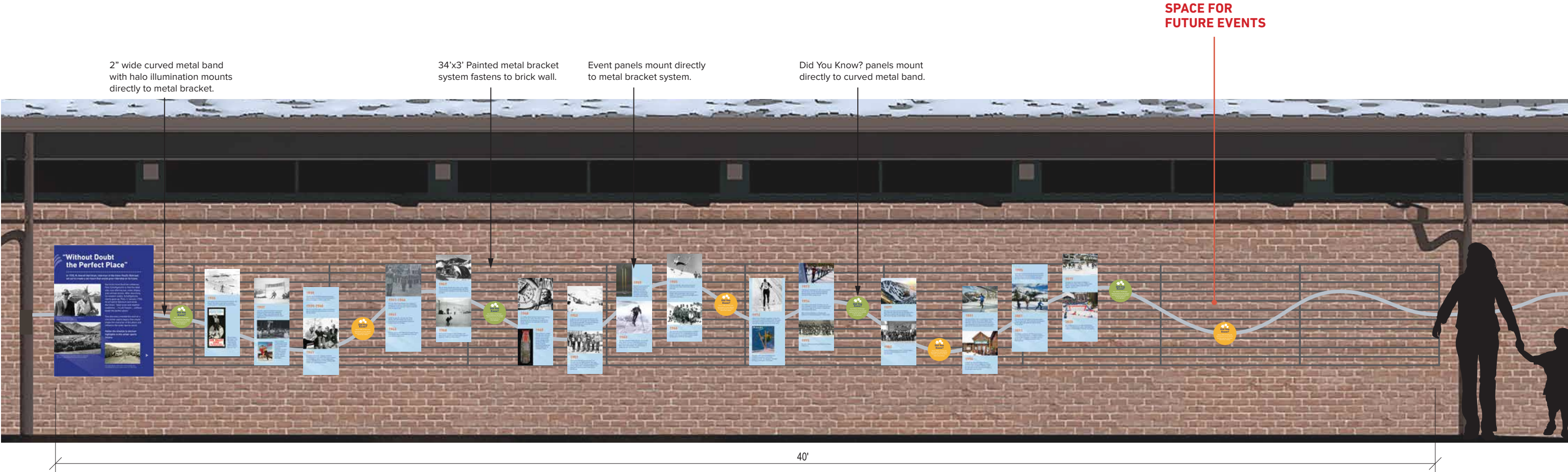

1 08-c01TIMELINE
Scale: 1/2"=1'-0"

ELEVATION



2 08-c01 TIMELINE
Scale: 1/8"=1'-0"

ELEVATION

08-C01: TIMELINE - DETAILS

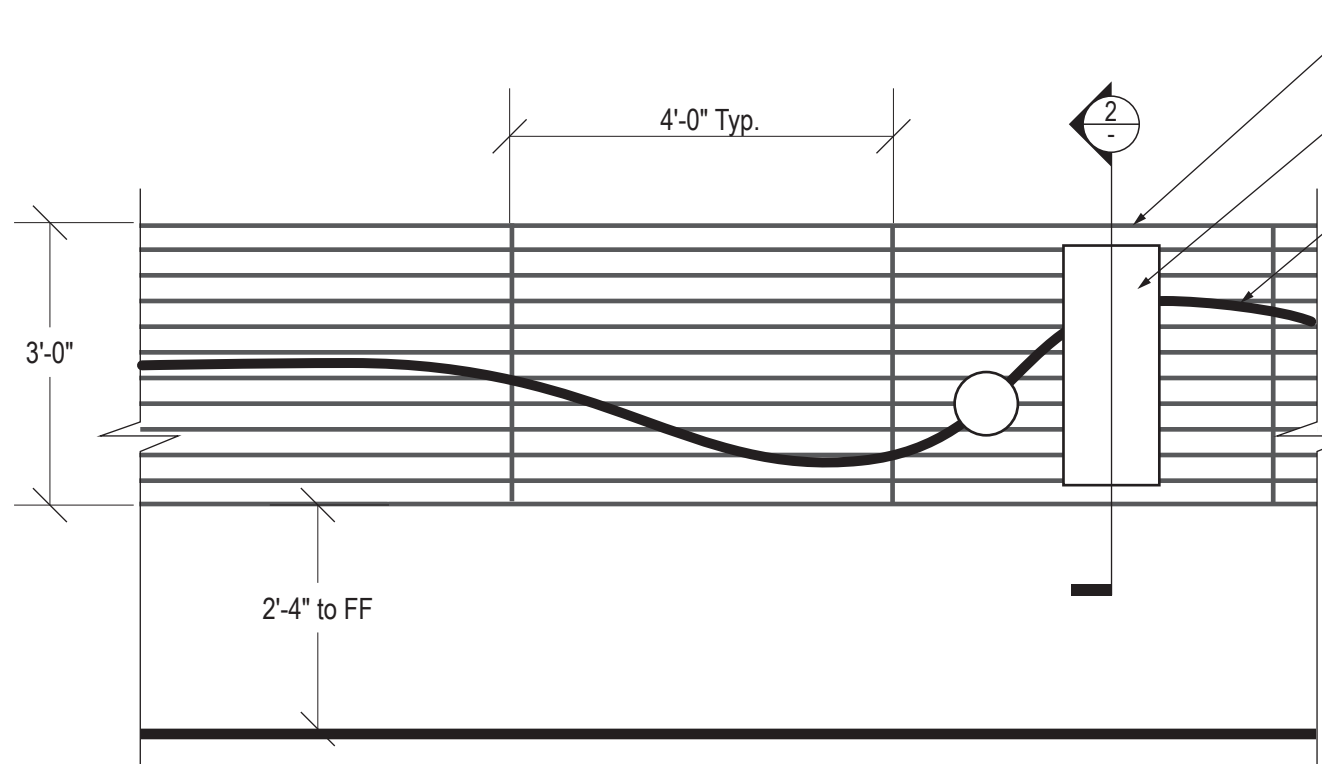

1 08-c01-o01 TIMELINE BRACKET
Scale: 1/2"=1'-0"
ELEVATION

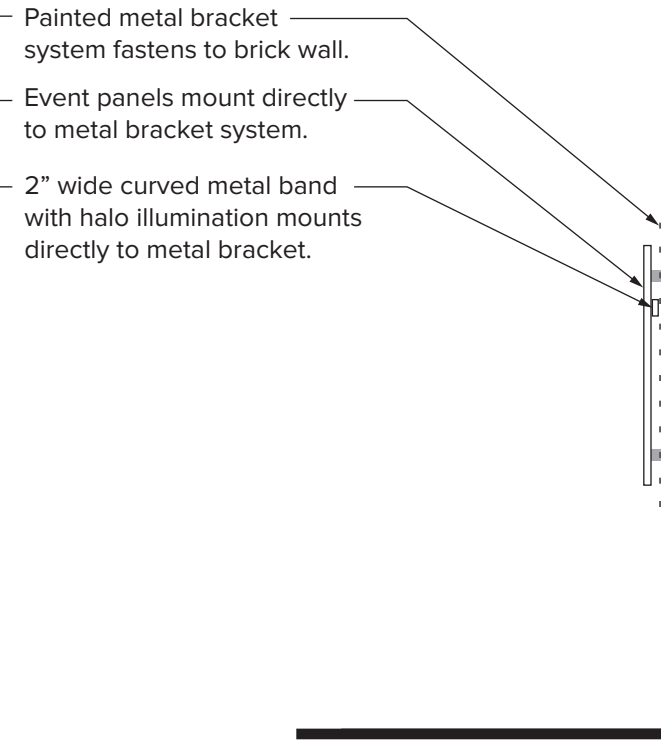

2 08-c01 TIMELINE BRACKET
Scale: 1/2"=1'-0"
SECTION

- Painted metal bracket system fastens to brick wall.
- Event panels mount directly to metal bracket system.
- 2" wide curved metal band with halo illumination mounts directly to metal bracket.

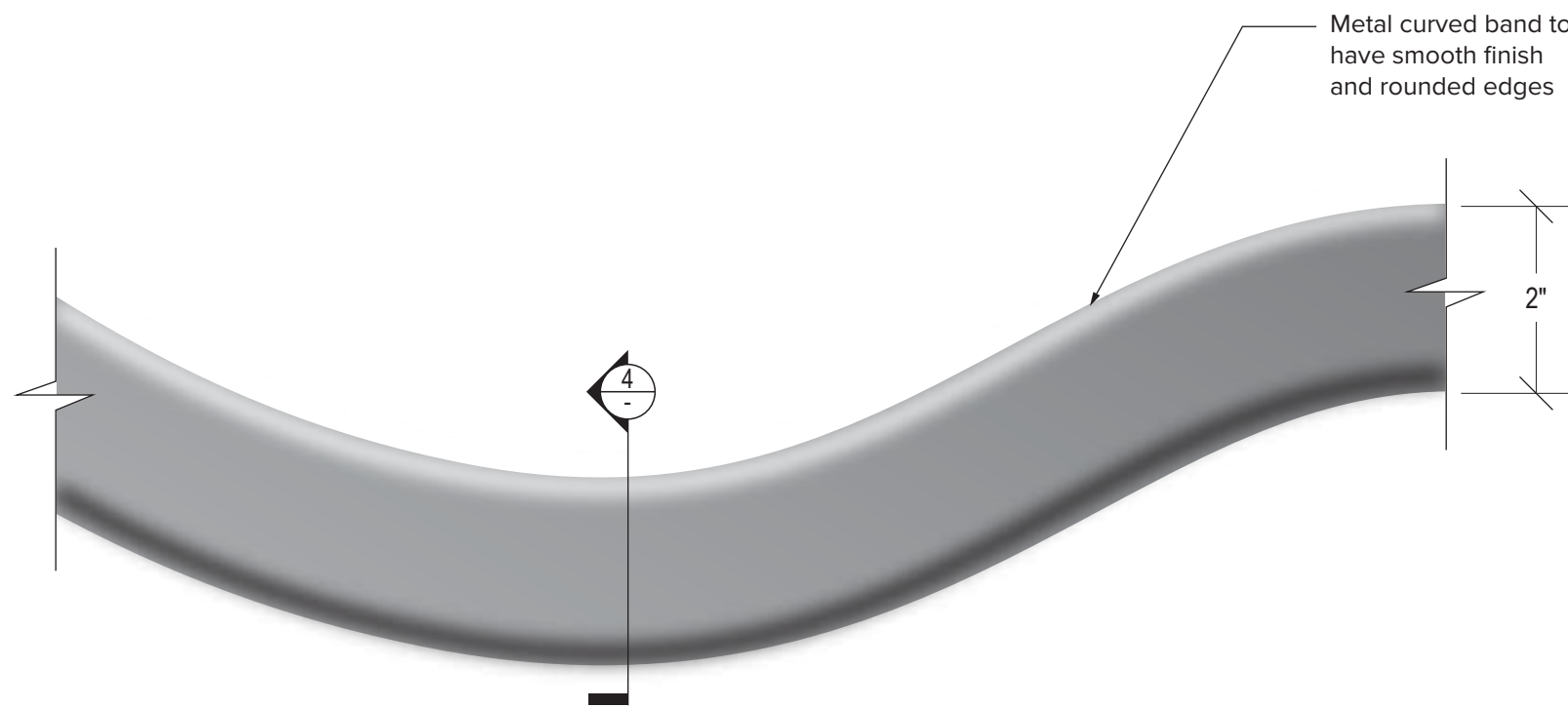

3 08-c01-o02 TIMELINE CURVED BAND
Scale: 6"=1'-0"
ELEVATION

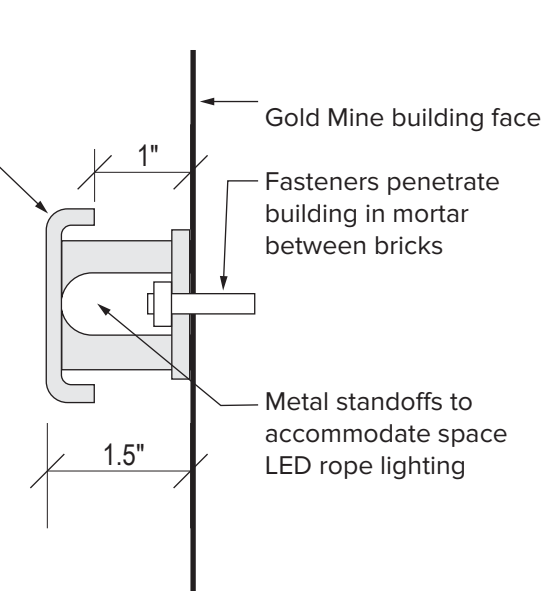

4 08-c01-o02 TIMELINE CURVED BAND (NO BRACKET AREA)
Scale: 6"=1'-0"
SECTION

- Metal curved band to have smooth finish and rounded edges
- Gold Mine building face
- Fasteners penetrate building in mortar between bricks
- Metal standoffs to accommodate space LED rope lighting

08-c01-g01 TIMELINE INTRO PANEL

Size: 34"x45"

Substrate: 1/2" Phenolic Resin

NOTES FOR CLIENT:

Hi Res Photos needed

Photo credit needed

“Without Doubt the Perfect Place”

In 1935, W. Averell Harriman, chairman of the Union Pacific Railroad, set out to create a ski resort that would grow ridership on its trains.



Harriman (right), with Count Felix Schaffgotsch outside the Sun Valley Lodge, 1936

Harriman hired Austrian nobleman Felix Schaffgotsche to find the ideal site—one offering sun, snow, slopes, and railroad access. After searching six western states, Schaffgotsche nearly gave up. Then, in January 1936, he arrived in Ketchum and wired Harriman: “ideal snow and weather conditions ... it’s ski heaven ... without doubt the perfect place.”

This discovery marked the start of a rich winter sports legacy that would shape the character of this place and influence the wider sports world.

Follow the timeline to discover highlights in this winter sports history.



When the resort began operations, Ketchum had about 200 year-round residents and only two small hotels.



The lodge opened in December 1936 to guests who had traveled 48 hours by special train from New York!

08-c01-g01 TIMELINE INTRO PANEL

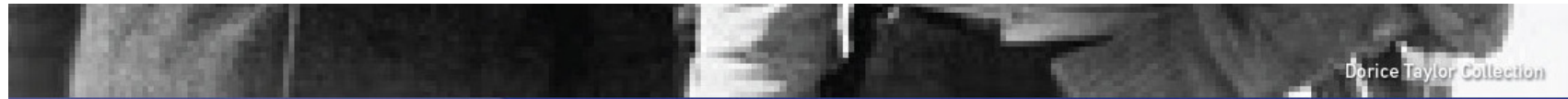

Harriman (right), with Count Felix Schaffgotsch outside the Sun Valley Lodge, 1936



When the resort began operations, Ketchum had about 200 year-round residents and only two small hotels.



The lodge opened in December 1936 to guests who had traveled 48 hours by special train from New York!

NOTES FOR CLIENT:
Photo credit needed

08-c01-g02 TIMELINE EVENT PANELS

Size: 12"x30"

Substrate: 1/2" Phenolic Resin

NOTES FOR CLIENT:

- Hi Res Photos needed
- Photo credit needed

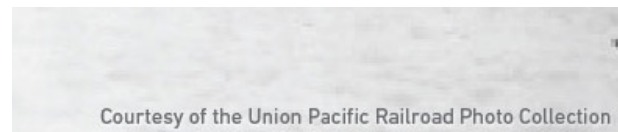

1936

The world's first chairlifts debut on Dollar and Proctor Mountains, inspired by a conveyor system used for loading bananas onto ships!

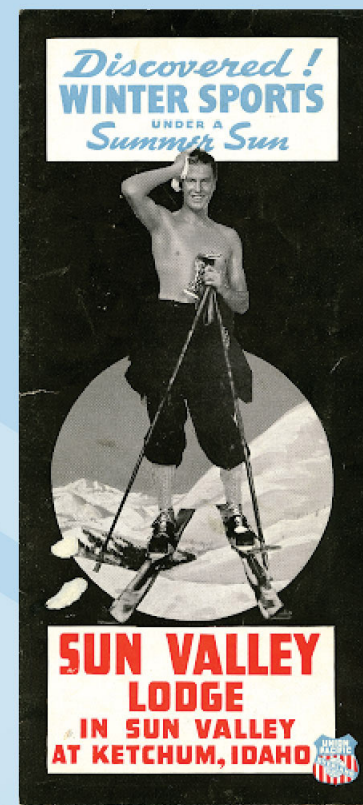

PR man Steve Hannagan coins the name Sun Valley and the tagline "Winter Sports Under a Summer Sun."

08-c01-g02a



1937

The first major international race at Sun Valley is the Harriman Cup, combining downhill, slalom, and alpine events. Ski legend and 1936 Olympian Dick Durrance takes the title.



The Sun Valley Skating Club forms, and Saturday night ice shows become a popular attraction. In 1939, Olympian Audrey Peppe is hired to run the resort's skating program and shows.

08-c01-g02b

1939

The Sun Valley Ski Patrol begins operating, with members trained in first aid, avalanche rescue, toboggan handling, and more.

1939-1940

The first chairlifts open on Baldy. The Round House restaurant serves skiers at the top of the second lift.



1941

Sun Valley Serenade, a popular romantic comedy, puts the ski resort into movie houses across America. Other movies filmed here include *I Met Him in Paris* (1937) and *Bus Stop* (1956), starring Marilyn Monroe.

08-c01-g02c

08-c01-g02 TIMELINE EVENT PANELS

Size: 12"x30"

Substrate: 1/2" Phenolic Resin

NOTES FOR CLIENT:

Hi Res Photos needed

Photo credit needed

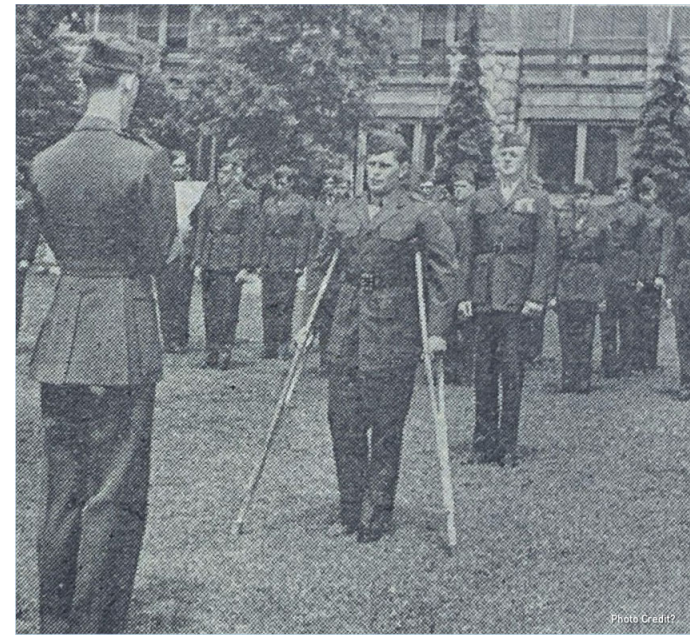
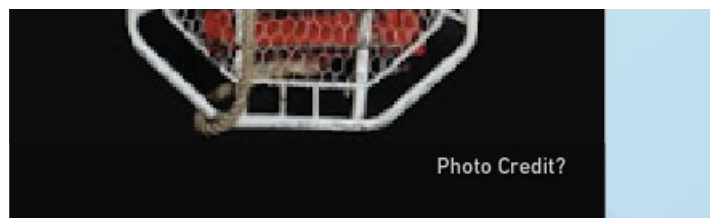
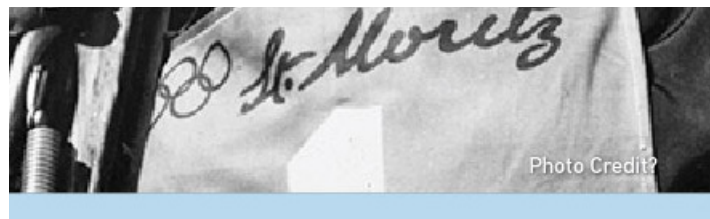
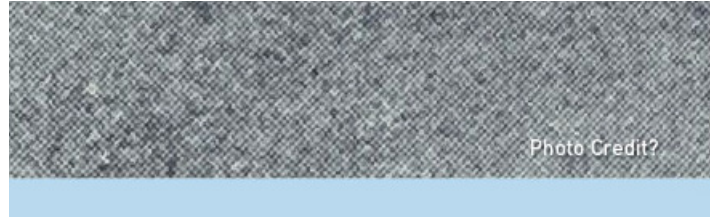

1941-1946

The U.S. Navy commissions Sun Valley as a convalescent hospital. More than 6,500 Navy and Marine Corps patients receive treatment here during the war.

1941

On December 8th, one day after Pearl Harbor, the FBI arrests three local ski instructors as suspected Nazi spies due to their Austrian heritage.

1943

The U.S. Army's 10th Mountain Division forms. Over 40 Sun Valley employees join, from ski instructors to patrolmen.

08-c01-g02d



1947

Warren Miller spends the winter in Sun Valley "ski bumming" in his teardrop trailer. His films of alpine skiers introduce a new way of seeing the sport.



1948

Rotarun ski hill opens west of Hailey, soon becoming a hub for local skiers and a popular place for children to learn to ski.

08-c01-g02e



1948

Sun Valley hosts Olympic tryouts and training for the U.S. Ski Team. Gretchen Fraser becomes the first American to medal at the Winter Olympics, winning gold in St. Moritz, Switzerland.



1949

Nelson Bennett, a WWII 10th Mountain Division veteran and ski patrol leader, reinvents the rescue toboggan with his brother, Ed. Their design includes controlled braking and a removable litter to transport victims.

08-c01-g02f

08-c01-g02 TIMELINE EVENT PANELS

Size: 12"x30"

Substrate: 1/2" Phenolic Resin

NOTES FOR CLIENT:

- Hi Res Photos needed
- Photo credit needed

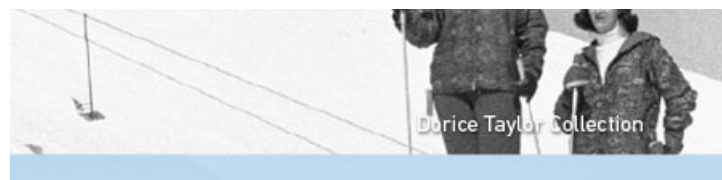

1952

A big snow year causes two avalanches. On Baldy, one kills four people and changes how the ski patrol operates. The second destroys Owl Creek Cabin, one of Sun Valley's backcountry ski lodges.



1957

The first Kindercup races for three- to 10-year-olds are held on Dollar Mountain. Local legends Picabo Street, Langley McNeal, Graham Watanabe, and Wyatt Caldwell are among the future ski stars who win the Kindercup.

08-c01-g02g



1959

Ed Scott invents tapered aluminum ski poles in his Ketchum repair shop. His innovation becomes a worldwide sensation and makes bamboo poles obsolete.



1963

The last legendary Diamond Sun race is held after safety concerns override the thrills of running an open course top to bottom of the River Run side of Baldy. The time to beat is three minutes and 10 seconds!

08-c01-g02h



1965

Olympic skier Bill Janss (pictured above) purchases the resort from Union Pacific Railroad.

Bob Smith invents the first double-lens ski goggle with a breathable foam venting system. In 1971, he moves Smith Optics from Colorado to Ketchum.



1966

Sun Valley Ski Education Foundation (SVSEF) forms to provide ski racing opportunities for juniors. Over the course of its history, SVSEF has produced 25 Winter Olympians.

08-c01-g02i

08-c01-g02 TIMELINE EVENT PANELS

Size: 12"x30"

Substrate: 1/2" Phenolic Resin

NOTES FOR CLIENT:

Hi Res Photos needed

Photo credit needed

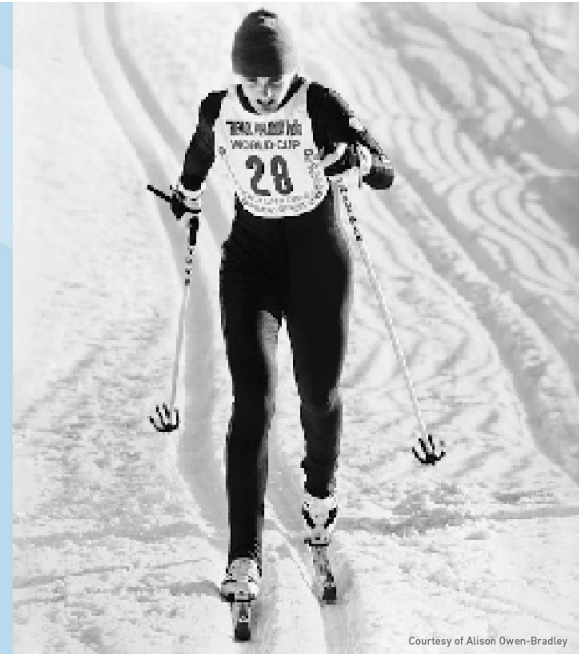
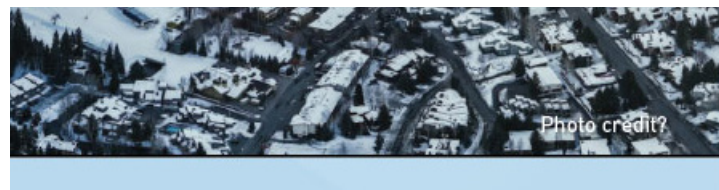
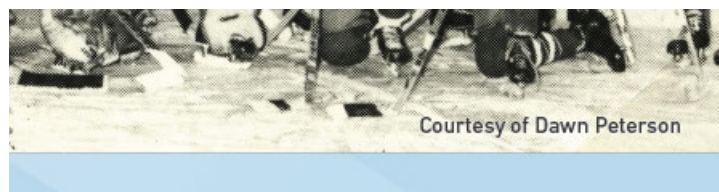
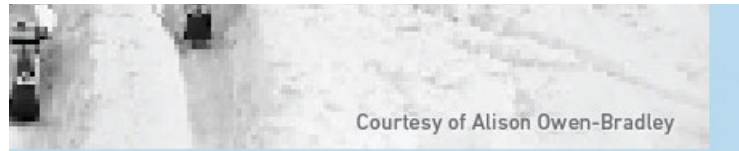

1972

Alison Owen-Bradley competes on the first U.S. Olympic women's Nordic team. U.S. men have been racing in the Games since 1924, and women outside of the U.S. since 1952.

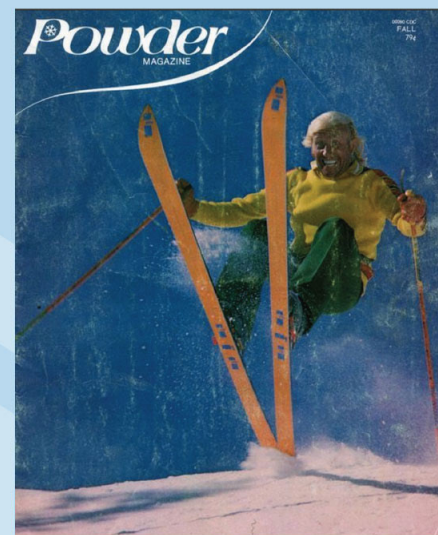

Brothers Jake and Dave Moe launch *POWDER* magazine in Ketchum, highlighting the "hot dogging" freestyle skiing popularized in Sun Valley.

08-c01-g02j



1973

The Boulder Mountain Tour ski race is held for the first time over 34 kilometers between Galena Lodge and the Sawtooth National Recreation Area headquarters.

1974

Sun Valley resort opens an indoor ice rink, after decades of using a refrigerated ice sheet behind the lodge for ice shows, competitions, and skating instruction.

Rail service to Ketchum—including the glamorous "Snowball Express"—finally ends.



1975

The Sun Valley Suns semi-professional hockey team forms.

08-c01-g02k



1977

Entrepreneurs Earl and Carol Holding purchase the resort. In the coming years, Sun Valley will expand with day lodges at River Run, Warm Springs, Seattle Ridge, and Dollar.



1982

A new women's hockey team, The Sun Valley Sunsets, begins traveling to regional tournaments.

08-c01-g02l

08-c01-g02 TIMELINE EVENT PANELS

Size: 12"x30"

Substrate: 1/2" Phenolic Resin

NOTES FOR CLIENT:

Hi Res Photos needed

Photo credit needed

Content numbers needed for 2011

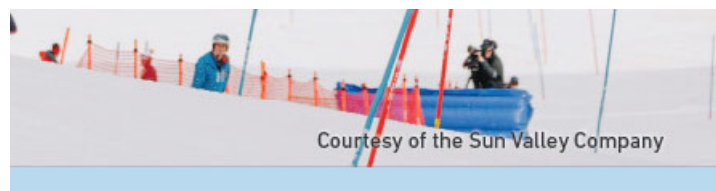
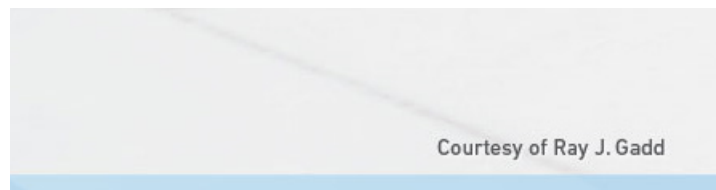
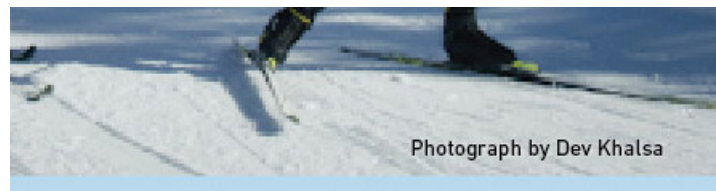
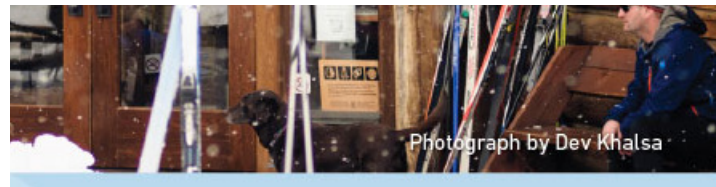

1991

The Wood River Trail is completed along the old Union Pacific rail line from Bellevue to Ketchum. This 20-mile paved trail is free to use and groomed by Blaine County Recreation District for cross-country skiing each winter.



1994

A Nordic ski area and restaurant are established at Galena Lodge, an historic structure and waystation dating to 1879. It's operated for the community by Blaine County Recreation District.

08-c01-g02m

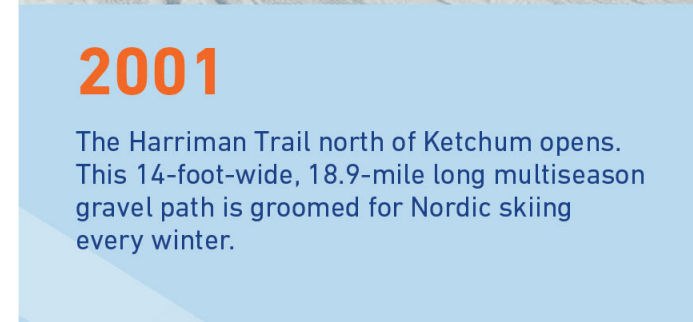

08-c01-g02n

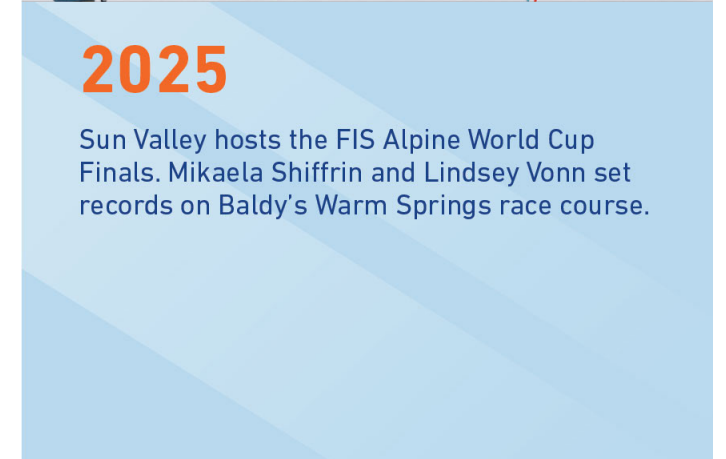
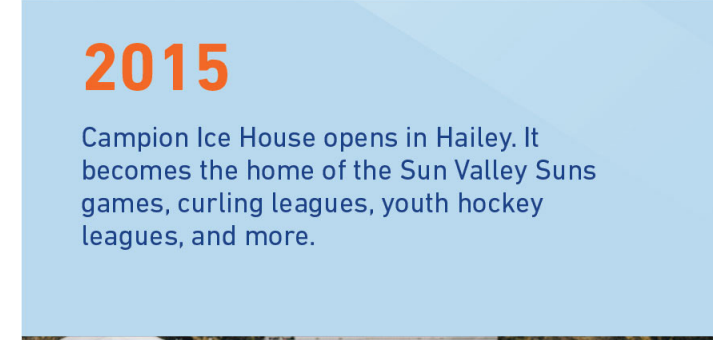

08-c01-g02o

08-c01-g03 TIMELINE "DID YOU KNOW?" PANELS

Size: 8" dia.

Substrate: 1/2" Phenolic Resin



NOTES FOR CLIENT:
Content numbers needed

03-C01: SECONDARY INTRO PANEL (ALLEY ENTRY)

Size: 28"x48"

Substrate: 1/2" Phenolic Resin

Phenolic resin graphic panel mounts to brickwall with cleat system, proud of curved rail.

28"



48"



Curved metal rail.

1 03-c01-g01 SECONDARY INTRO PANEL
Scale: 1 1/2"=1'-0" ELEVATION

2 03-c010g01 SECONDARY INTRO PANEL
Scale: 1/2"=1'-0" ELEVATION

10-C01: DIRECTIONAL SIGN (ALLEY ENTRY)

Size: 19"x25"

Substrate: 1/2" Phenolic Resin

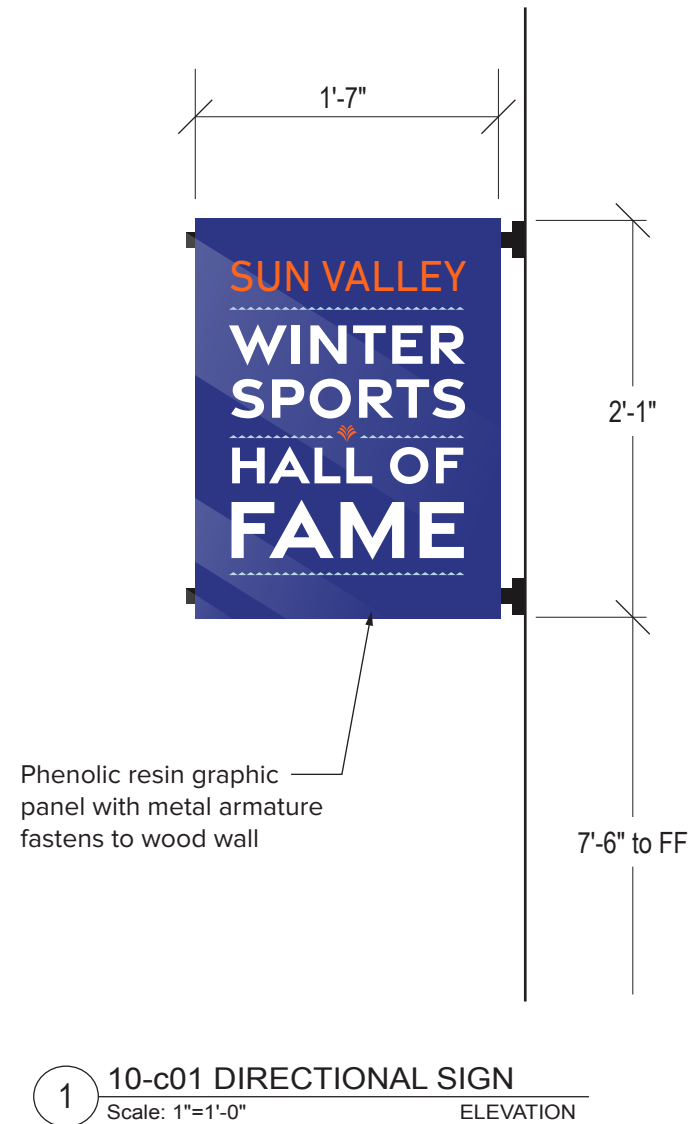

Photo rendering 1



Photo rendering 2

09-C01: GOLD MINE SCREEN

Size: 13'x5'9"
 Substrate: Painted Steel frame, panel, and mesh

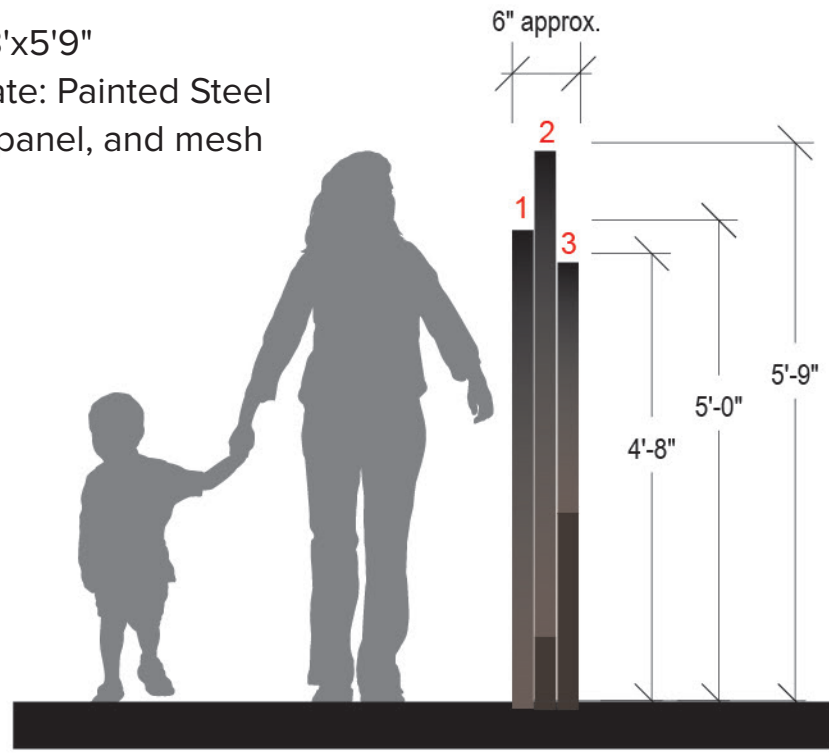

Side View

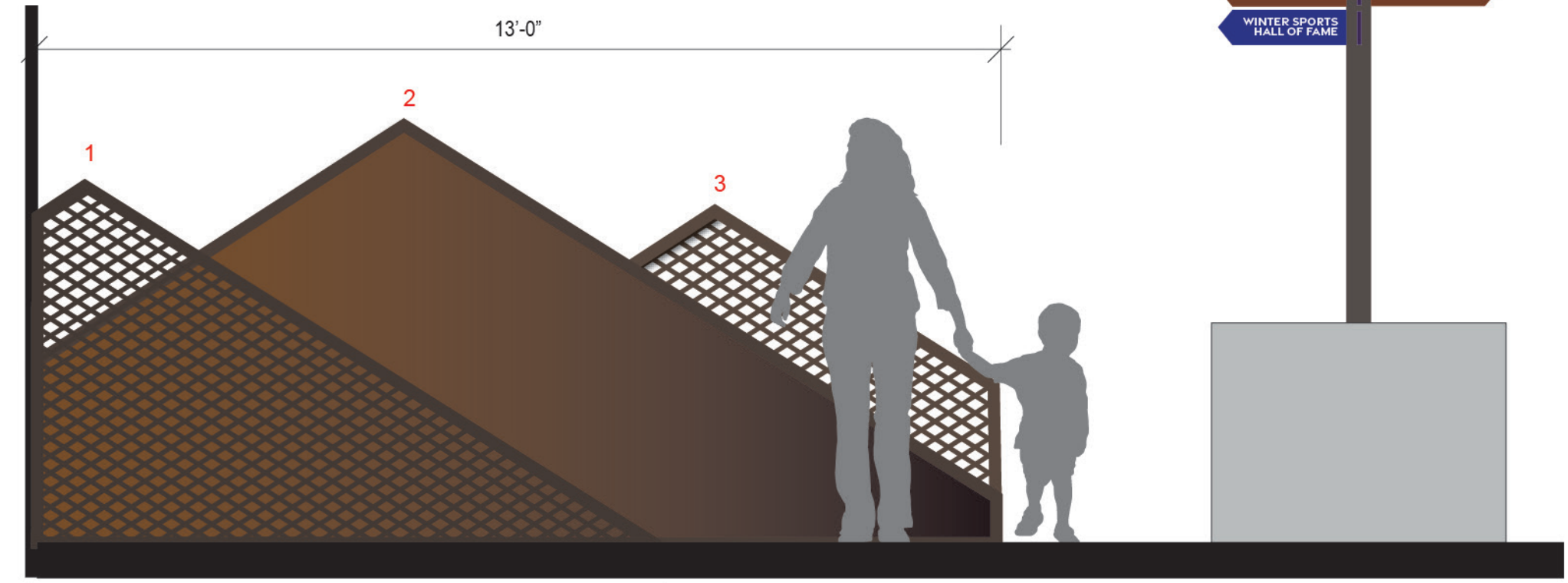

Side B - Gold Mine Side

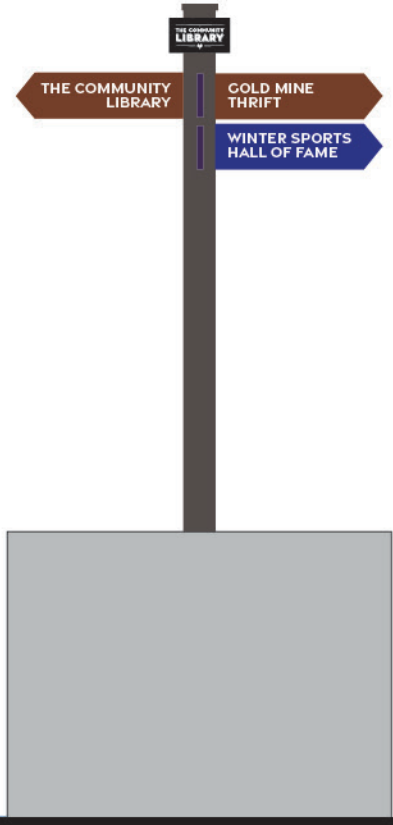
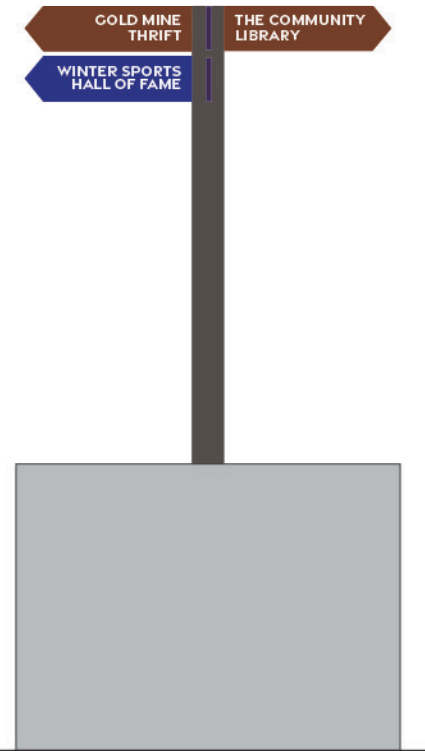

Three painted steel panels with frames. Center panel solid, outside panels are perforated (or mesh) steel. Each of the three frames are secured to each other and to the finished floor. Two of the frames are fastened to the side of the Gold Mine wall for increased stability.

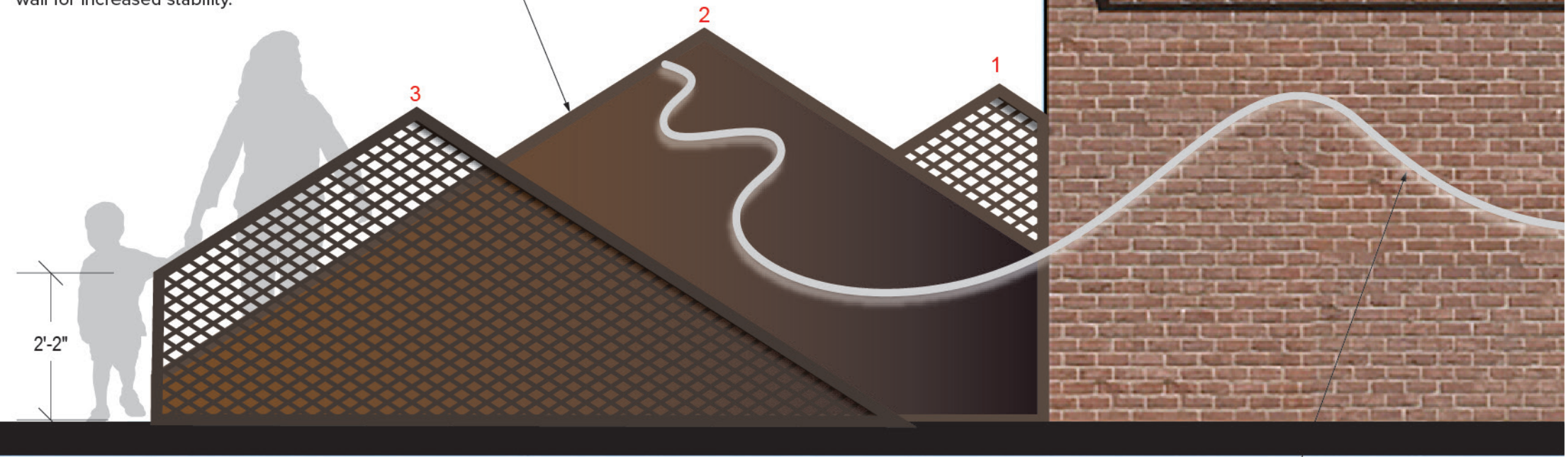

Side A - Museum side

2" wide metal band with halo illumination mounts directly to Gold Mine wall and screen panels with fasteners.

1 09-c01 GOLD MINE SCREEN
 Scale: 1/2"=1'-0"

ELEVATION

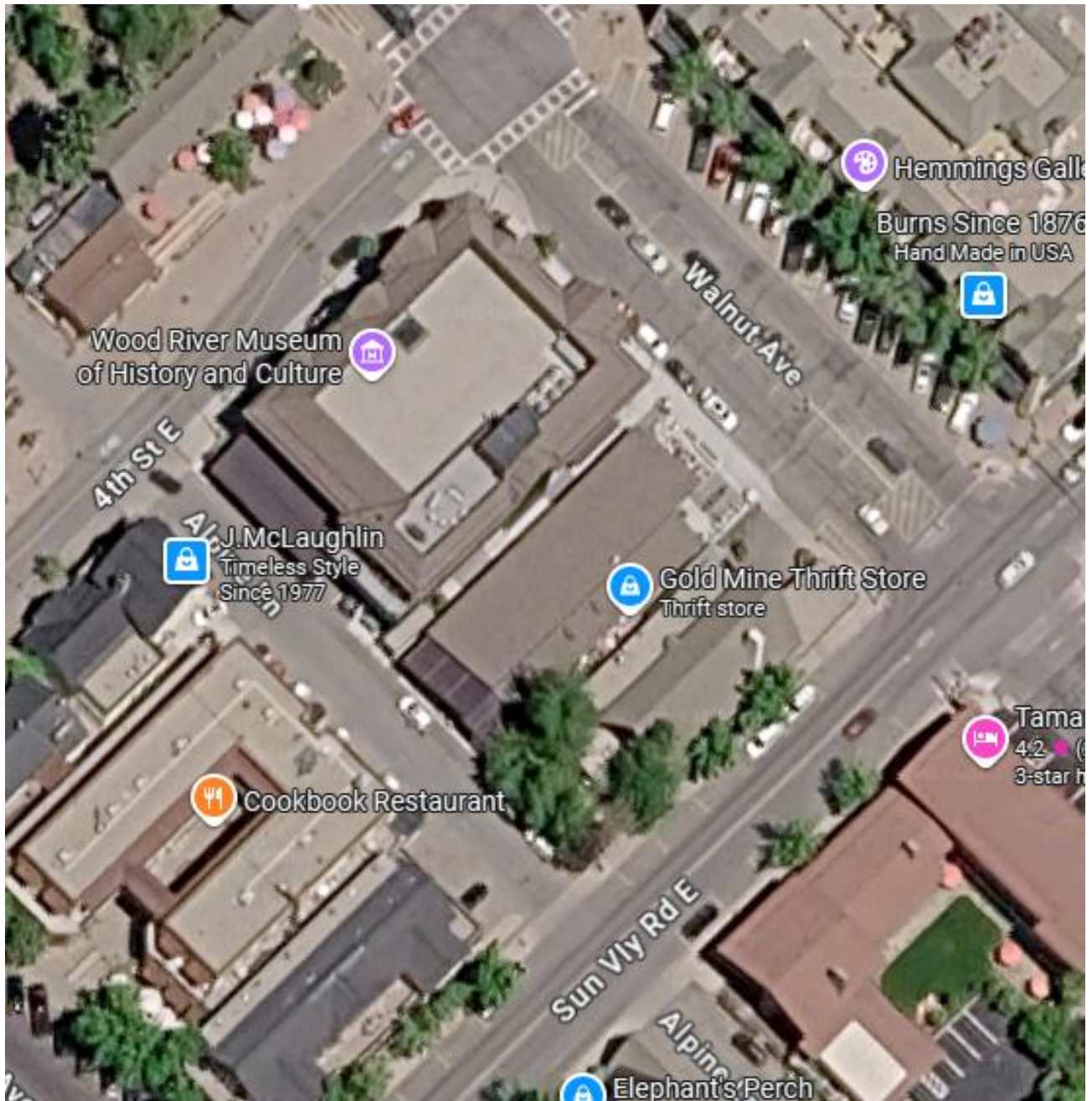

Vicinity Map

History of the Building

The property was donated by Union Pacific in 1955 to provide the site for the construction of a privately-funded public library. In 1957, The Community Library opened in the new building at that site, and it included the Gold Mine Thrift Store in the building: The Library occupied the front room, and the thrift store – which helps fund library operations – occupied the back room. In 1976, given the growth of both operations, a new building was constructed for the Library on Spruce Avenue, and the Gold Mine occupied all of the Walnut Avenue building. The Walnut Avenue building has expanded to the west (the back end of the building), and a covered drop-off area along Alpine Way was added in 2024.



The Community Library / Gold Mine Building, circa 1957

Courtesy of The Community Library's Jeanne Rodger Lane Center for Regional History



Wednesday, May 6, 2026 at 3:41 PM

Side of the Gold Mine Store where the Winter Sports Hall of Fame Timeline would be installed.



Wednesday, May 6, 2026 at 3:40 PM

Side of the Gold Mine Store where the Winter Sports Hall of Fame Timeline would be installed.



Wednesday, May 6, 2026 at 3:40 PM

Front of the Gold Mine Store.

DONATION WARRANTY DEED

THE UNION LAND COMPANY TO THE COMMUNITY LIBRARY ASSOCIATION, JNC.

DONATION WARRANTY DEED

C. D. No. 41761

from

THE UNION LAND COMPANY

to

THE COMMUNITY LIBRARY ASSOCIATION, INC.

Dated October 11, 1955.

9-14-55

Covering parcel of land in Blaine County, Idaho.

ORIGINAL

THIS INDENTURE, Made this 11th day of October, 1955 between THE UNION LAND COMPANY, a corporation of the State of Nebraska, Grantor, and THE COMMUNITY LIBRARY ASSOCIATION, INC., of Ketchum, Blaine County, Idaho, a non-profit corporation of the State of Idaho, Grantee:

WITNESSETH, That

WHEREAS, the Grantee desires to acquire the property hereinafter described for the purpose of constructing and maintaining thereon a building to be used as a community library; and

WHEREAS, the Grantor is willing to donate said property to the Grantee;

NOW THEREFORE, in consideration of the premises, the Grantor does by these presents donate, grant, convey and confirm unto the said Grantee, its successors and assigns forever, the following described real estate situate in the Town of Ketchum, Blaine County, Idaho, to wit:

All of Lot 6 in Block 44, of the Town of Ketchum, Blaine County, Idaho, according to the official plat thereof on file in the office of the County Recorder of said Blaine County, Idaho.

EXCEPTING from this grant and RESERVING unto the Grantor, its successors and assigns forever, all minerals and all mineral rights of every kind and character now known to exist or hereafter discovered, including without limiting the generality of the foregoing, oil and gas and rights thereto, together with the sole, exclusive and perpetual right to explore for, remove and dispose of, said minerals by any means or methods suitable to the Grantor, its successors and assigns, but without entering upon or using the surface of the lands hereby conveyed, and in such manner as not to damage the surface of said lands or to interfere with the use thereof by the Grantee, its successors or assigns.

SUBJECT to all taxes and all assessments, general and special, and all installments of assessments lawfully levied upon or assessed against the premises hereinbefore described which become due and payable subsequent to the date hereof, which taxes and assessments the Grantee hereby assumes and agrees to pay.

TOGETHER with all and singular the tenements, hereditaments and appurtenances to said premises belonging or in anywise appertaining, the reversion and reversions, remainder and remainders, rents, issues and profits thereof, and all estate, right, title and interest in and to said property, as well in law as in equity, of the said Grantor, except as herein specifically excepted and reserved.

TO HAVE AND TO HOLD, all and singular the above-mentioned and described premises, together with the appurtenances, unto the said Grantee and its successors and assigns forever, subject to the foregoing exceptions, reservations and taxes.

AND, subject to the said exceptions, reservations and taxes, the said Grantor, its successors and assigns, the said premises in the quiet and peaceable possession of the said Grantee, its successors and assigns against the said Grantor, and its successors and assigns, and against all and every person or persons whomsoever lawfully claiming or the claim the same shall and will warrant and by these presents forever defend.

IN WITNESS WHEREOF, the said Grantor has caused these presents to be executed by its President thereunto duly authorized and to be attested by its Assistant Secretary and has caused its corporate seal to be affixed the day and year first above written.

Witness:
M. E. Thomas

(SEAL)

THE UNION LAND COMPANY
By A. E. Stoddard
President

Attest:
L. J. Bachman (SEAL)
Assistant Secretary

STATE OF NEBRASKA)
)ss.
COUNTY OF DOUGLAS)

On this 17th day of October, 1955, before me, a Notary Public in and for said county in the State aforesaid, personally appeared A. E. Stoddard to me personally known. and to me personally known to be President of THE UNION LAND COMPANY, and to be the same person whose name is subscribed to the foregoing instrument, and who, being by me duly sworn, did say that he is President of The Union Land Company, that the seal affixed to said instrument is the corporate seal of said corporation; and that said instrument was signed and sealed on behalf of said corporation by authority of its board of directors; and the said A. E. Stoddard acknowledged said instrument to be his free and voluntary act and deed, and the free and voluntary act and deed of said corporation, by it voluntarily executed, for the uses specified therein.

IN WITNESS WHEREOF, I have hereunto set my hand and official seal the day and year last above written.

(SEAL)

My commission expires MAY 10, 1960.

Louis Scholnick
Notary Public

Filed for record at the request of G. R. Kneeland at 11:00 o'clock A. M. November 21, 1955.

George F. McCoy, Ex-Officio Recorder
By Goldie Rayborn, Deputy.



Lot Book Report – Full Search

File No.: 906247

Reference No.:

1. Effective Date: May 7, 2026 7:00AM
2. The estate or interest in the land described or referred to in this Lot Book Report is:

FEE SIMPLE

3. Title to the estate or interest in the land is at the Effective Date vested in:

The Community Library Association, Inc.

4. The land referred to in this Lot Book Report is described as follows:

Lot 6, Block 44 of the CITY OF KETCHUM, BLAINE COUNTY, IDAHO, according to the official plat thereof on file in the office of the County Recorder of Blaine County, Idaho.

File No.: 906247

Reference No.:

Special Exceptions:

1. First/Second Subsequent tax for the year 2025 are exempt.
Parcel No.: [RPK00000440060](#)
Amount: \$0.00
2. General taxes for the year 2026, which are liens and are not yet due and payable.
Parcel No.: RPK00000440060
3. Reservations in United States Patent or State Deeds.
4. Water rights, claims or title to water, whether or not the matters are shown by the public records.
5. Rights of way for ditches, tunnels and telephone and transmission lines constructed by Authority of the United States, as granted to the United States under the provisions of Section 58-604 Idaho Code 1947.
6. Sewer charges and special assessments, if any, for the City of Ketchum.
No search made.
7. Covenants, conditions, restrictions and easements as set forth on the plat.
Name of Plat: [City of Ketchum](#)
8. Reservations contained in an instrument
Document: Donation Warranty Deed
Dated:
Executed by: The Union Land Company
Recorded: November 21, 1955
Instrument No.: 107021
As Follows: Excepting and reserving unto the Grantor, its successors and assigns forever, all minerals and all mineral rights of every kind and character now known to exist or hereafter discovered, including, without limiting the generality of the foregoing, oil and gas and rights thereto, together with the sole, exclusive and perpetual right to explore for, remove and dispose of, said minerals by any means or methods suitable to the Grantor, its successor and assigns, but without entering upon or using the surface of the land hereby conveyed, and in such manner as not to damage the surface of said lands or to interfere with the use thereof by the Grantee, its successors or assigns.

End of Exceptions

No liability beyond the amount paid for this report is assumed hereunder, and Pioneer Title is not responsible beyond the amount paid for any errors and omissions contained herein. If you wish additional assurances, please contact Pioneer Title for further information as to the availability and cost of additional protection.

by:



Nick Busdon