

**SITE INFORMATION:**

Legal Description: 1020 Prospect Lane  
 Site Address: 1020 Prospect Lane  
 Parcel #: 322092101  
 Current Use: Industrial  
 Proposed Use: Industrial

Current Zoning: IPD- Industrial Park District  
 Adjacent Zoning:  
 North - IPD  
 South - IPD  
 East - IPD  
 West - IPD

**Site Areas**  
 Parcel Area: 144,219 SF (3.31 Acres)

Existing Building Area: 10,400 SF  
 Existing Pavement Area: 74,469 SF  
 Existing Sidewalk Area: 3,662 SF  
 Total Existing Impervious: 88,531 SF (61.39%)

Additional Building Area: 0 SF  
 Additional Pavement Area: 38,577 SF  
 Additional Sidewalk Area: 0 SF  
 Total Additional Impervious: 38,577 SF (26.75%)

Total Proposed Building Area: 10,400 SF  
 Total Proposed Pavement Area: 111,380 SF  
 Total Proposed Sidewalk Area: 0 SF

Total Proposed Impervious: 121,780 SF (84.44%)  
 Total Proposed Greenspace: 22,439 SF (15.56%)

**PROPERTY OWNER:**  
 Team Industries, Inc.  
 Jason Sturn  
 1200 Maloney Road  
 Kaukauna, WI 54130  
 Telephone: (920) 462-1158  
 Email: jsturn@teamind.com

**LEGEND**

— CATV — CATV	Underground Cable TV	○ Sanitary MH / Tank / Base	□ CATV Pedestal
— FO — FO	Underground Fiber Optic	○ Clean Out / Pull Box	□ Telephone Pedestal
— OH — OH	Overhead Utility Lines	○ Storm Manhole	□ Telephone Manhole
— UGW — UGW	Utility Guy Wire	○ Inlet	□ Gas Regulator
— SS — SS	Sanitary Sewer (Pipe Size)	○ Catch Basin / Yard Drain	□ Sign
— S — S	Storm Sewer (Pipe Size)	○ Water MH / Well	□ Post / Guard Post
— E — E	Underground Electric	○ Curb Stop	□ Benchmark
— G — G	Underground Gas Line	○ Hydrant	□ Asphalt Pavement
— T — T	Underground Telephone	○ Utility Valve	□ Concrete Pavement
— W — W	Water Main (Pipe Size)	○ Utility Meter	□ Gravel
— F — F	Fence - Steel	○ Utility Pole	□ Proposed Building
— Tr — Tr	Tie Line	○ Light Pole / Signal	□ Proposed Asphalt
— C — C	Culvert	○ Guy Wire	□ Proposed Concrete
— 300 — 300	Index Contour - Existing	○ Electric Pedestal	□ Proposed Gravel
— 799 — 799	Intermediate Contour - Existing	○ Electric Transformer	
		○ Electric Manhole	
		○ Air Conditioner	

**SHEET INDEX:**

Sheet	Page
Site Plan	C1.0
Topographic Survey	C1.1
Drainage and Grading Plan	C1.2
Erosion & Sediment Control Plan	C1.3
Construction Details	C2.1
Erosion & Sediment Control Details	C2.2
Stormwater Pond Details	C2.3



6/12/2026 11:51 AM J:\Projects\9385\engr.dwg Civil 3D\9385\engr.dwg Printed by: augustus

**DAVEL ENGINEERING & ENVIRONMENTAL, INC.**  
 Civil Engineers and Land Surveyors  
 1164 Province Terrace, Menasha, WI 54952  
 Ph: 920-991-1866  
 www.davel.pro

**SITE PLAN**

**1020 Prospect Lane**  
 City of Kaukauna, Outagamie County, WI  
 For: Team Industries, Inc.

Date: 06/12/2026

Filename: 9385\engr.dwg

Author: TNW

Last Saved by: augustus

Page: C1.0

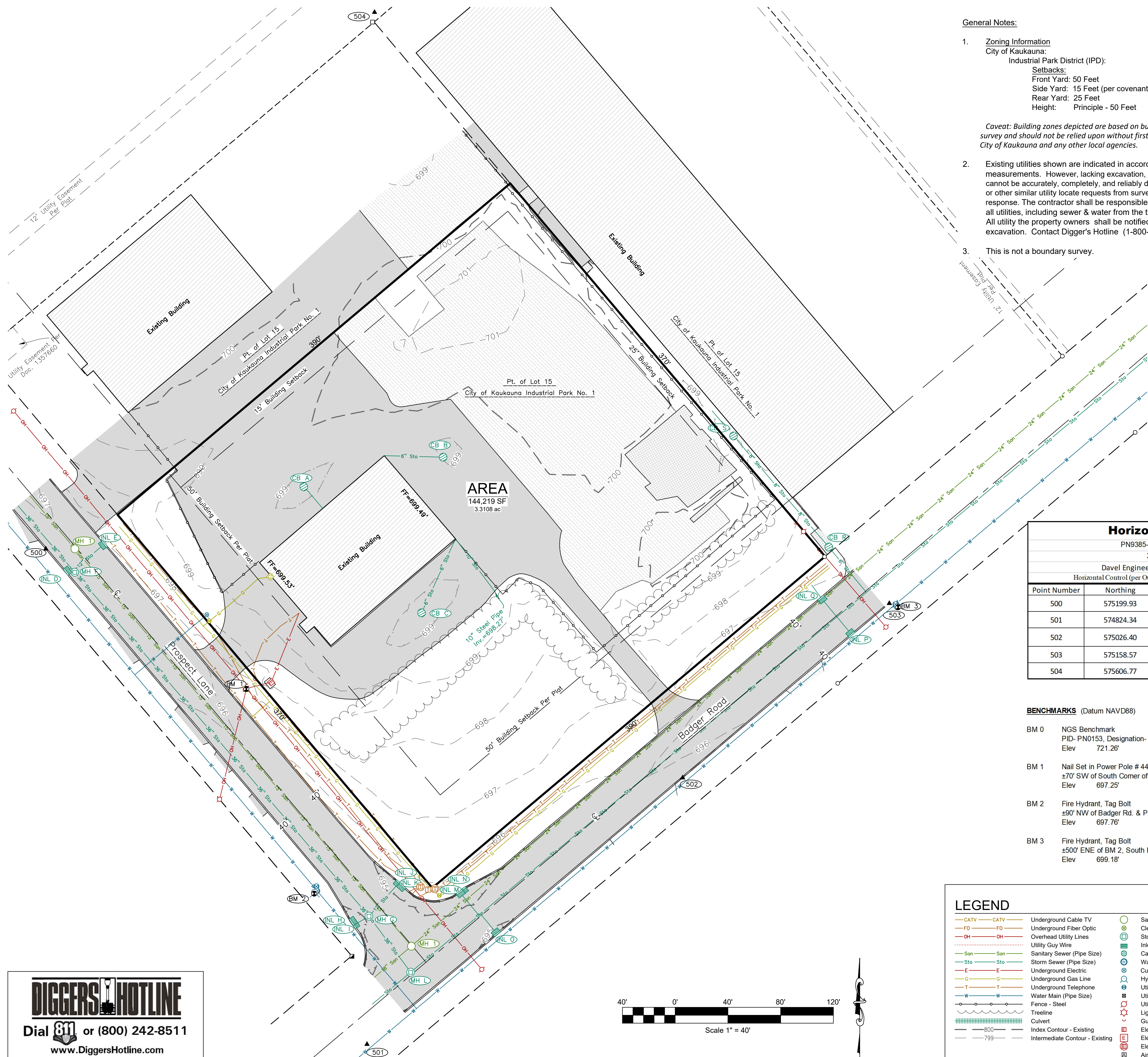

**General Notes:**

- Zoning Information**  
 City of Kaukauna:  
 Industrial Park District (IPD):  
 Setbacks:  
 Front Yard: 50 Feet  
 Side Yard: 15 Feet (per covenants)  
 Rear Yard: 25 Feet  
 Height: Principle - 50 Feet  
  
*Caveat: Building zones depicted are based on building setbacks in effect at the time of the survey and should not be relied upon without first obtaining written verification thereof from the City of Kaukauna and any other local agencies.*
- Existing utilities shown are indicated in accordance with available records and field measurements. However, lacking excavation, the exact location of underground features cannot be accurately, completely, and reliably depicted. In addition, in some jurisdictions, 811 or other similar utility locate requests from surveyors may be ignored or result in an incomplete response. The contractor shall be responsible for obtaining exact locations & elevations of all utilities, including sewer & water from the the property owners of the respective utilities. All utility the property owners shall be notified by the contractor 72 hours prior to excavation. Contact Digger's Hotline (1-800-242-8511) for exact utility locations.
- This is not a boundary survey.

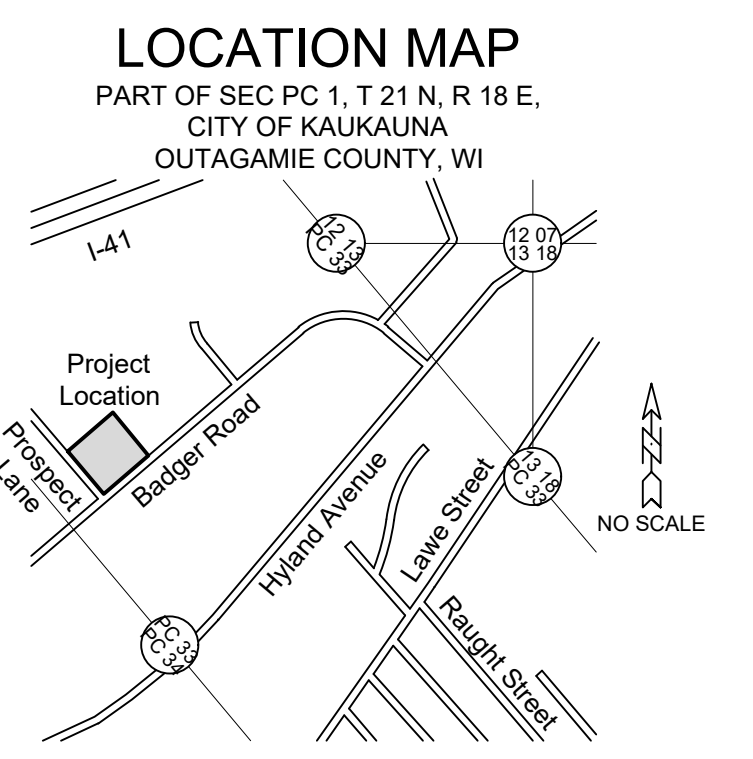

Horizontal Control			
PN9385 - (City of Kaukauna)			
2026-04-16			
Davel Engineering and Environmental			
Horizontal Control (per Outagamie County Coordinate System)			
Point Number	Northing	Easting	Description
500	575199.93	864625.99	CPT MAG
501	574824.34	864869.56	CPT MAG
502	575026.40	865108.89	CPT MAG
503	575158.57	865265.66	CPT MAG
504	575606.77	864875.25	CPT HUB

- BENCHMARKS** (Datum NAVD88)
- BM 0 NGS Benchmark  
 PID- PN0153, Designation- R 5  
 Elev 721.26'
  - BM 1 Nail Set in Power Pole # 44A1- 12/22  
 ±70' SW of South Corner of Exist Bld, Easterly R/W of Prospect Lane  
 Elev 697.25'
  - BM 2 Fire Hydrant, Tag Bolt  
 ±90' NW of Badger Rd. & Prospect Ln. Intersect., Westerly R/W of Prospect Ln.  
 Elev 697.76'
  - BM 3 Fire Hydrant, Tag Bolt  
 ±500' ENE of BM 2, South R/W of Badger Rd.  
 Elev 699.18'

**LEGEND**

— CATV	— CATV	○ Sanitary MH / Tank / Base	□ CATV Pedestal
— FO	— FO	○ Clean Out / Pull Box	□ Telephone Pedestal
— OH	— OH	○ Storm Manhole	□ Telephone Manhole
— UG	— UG	○ Inlet	□ Gas Regulator
— San	— San	○ Catch Basin / Yard Drain	□ Sign
— Sto	— Sto	○ Water MH / Well	□ Post / Guard Post
— E	— E	○ Curb Stop	○ Benchmark
— G	— G	○ Hydrant	○ Asphalt Pavement
— T	— T	○ Utility Valve	○ Concrete Pavement
— W	— W	○ Utility Meter	○ Gravel
— F	— F	○ Utility Pole	○ Ex Spot Elevation
— Tree	— Tree	○ Light Pole / Signal	○ 3/4" Rebar Found
— Culvert	— Culvert	○ Guy Wire	○ 1" Iron Pipe Found
— 800	— 800	○ Electric Pedestal	
— 799	— 799	○ Electric Transformer	
		○ Electric Manhole	
		○ Air Conditioner	

Storm Structures						
Structure	#	Rim	Inv	Size	Material	Direction
CB A	698.80	697.46	6"	PVC	SE	
		694.69	6"	PVC	SE	
CB B	698.93	694.85	6"	PVC	W	
CB C	698.57	694.80	6"	PVC	NE	
INL D	696.38	692.38	10"	PVC	NE	
INL E	696.37	692.02	10"	PVC	SW	
		691.07	36"	RCP	NW	
MH F	696.59	691.07	36"	RCP	SE	
		690.82	12"	RCP	NE	
MH G	695.10	690.82	12"	RCP	SW	
		689.60	36"	RCP	NW	
MH H	695.10	689.60	36"	RCP	SE	
		689.60	36"	RCP	SE	
INL I	694.85	691.65	12"	RCP	SE	
INL J	694.83	691.63	12"	RCP	NW	
		691.53	12"	RCP	NE	
INL K	694.86	691.24	12"	RCP	SW	
		691.13	12"	RCP	SE	
INL L	694.82	691.13	12"	RCP	NW	
		689.33	36"	RCP	NW	
MH M	695.42	687.13	66"	RCP	SW	
		687.13	78"	RCP	NE	
INL N	694.72	691.01	12"	RCP	NE	
		690.92	15"	RCP	SE	
INL O	694.74	691.03	12"	RCP	SW	
INL P	694.87	690.25	10"	PVC	NW	
INL Q	696.39	692.14	10"	PVC	NW	
		696.43	691.83	6"	PVC	NW
CB R	697.08	691.81	18"	PVC	SE	
		692.08	6"	PVC	SE	
CB S	698.68	693.18	8"	PVC	NW	
		694.98	8"	PVC	SE	
CB T	698.68	694.98	8"	PVC	SE	
		694.98	8"	PVC	NW	

Sanitary Structures						
Structure	#	Rim	Inv	Size	Material	Direction
MH 1	696.77	686.93	15"	PVC	NW	
		686.93	15"	PVC	SE	
MH 2	695.33	683.36	15"	PVC	NW	
		685.23	15"	PVC	NW	
MH 3	695.33	683.36	18"	PVC	SW	
		683.36	24"	PVC	NE	

**DIGGERS HOTLINE**  
 Dial 811 or (800) 242-8511  
 www.DiggersHotline.com

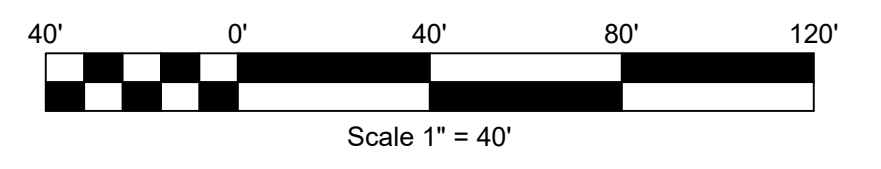

**TOPOGRAPHIC SURVEY**

**1020 Prospect Lane**  
 City of Kaukauna, Outagamie County, WI  
 For: Team Industries, Inc.

# DRAINAGE & GRADING PLAN

1020 Prospect Lane  
City of Kaukauna, Outagamie County, WI  
For: Team Industries, Inc.



- NOTES:**
- Existing utilities shown are indicated in accordance with available records and field measurements. The contractor shall be responsible for obtaining exact locations & elevations of all utilities, including sewer and water from the owners of the respective utilities. All utility owners shall be notified by the contractor 72 hours prior to excavation. Contact Digger's Hotline (1-800-242-8511) for exact utility locations.
  - The Contractor shall verify all staking and field layout against the plan and field conditions prior to constructing the work and immediately notify the Engineer of any discrepancies.
  - The contractor shall minimize the area disturbed by construction as the project is constructed. Disturbed areas shall be seeded as soon as final grade is established. Contractor shall replace topsoil and then seed, fertilize and mulch all lawn areas within 1 week of topsoil placement.
  - Contractor shall remove all excess materials from the site. Earthwork contractors shall verify topsoil depth.
  - All sediment and erosion control devices and methods shall be in accordance with the Wisconsin DNR Technical Standards.
  - The contractor shall make weekly inspections and inspections within 1 day of any rainfall exceeding 0.5 inches of the sediment and erosion control devices throughout construction. The contractor shall repair or maintain erosion control devices as necessary. The inspection reports shall be made available to the owner at the end of the construction or upon demand during construction.
  - Updated survey and title search have not been authorized and the boundary and easements shown may be inaccurate or incomplete.

**LEGEND**

— CATV — CATV	Underground Cable TV	○ Sanitary MH / Tank / Base	□ CATV Pedestal
— FO — FO	Underground Fiber Optic	○ Clean Out / Pull Box	□ Telephone Pedestal
— OH — OH	Overhead Utility Lines	○ Storm Manhole	□ Telephone Manhole
— UG — UG	Utility Guy Wire	○ Inlet	□ Gas Regulator
— S — S	Sanitary Sewer (Pipe Size)	○ Catch Basin / Yard Drain	□ Sign
— SS — SS	Storm Sewer (Pipe Size)	○ Water MH / Well	□ Post / Guard Post
— E — E	Underground Electric	○ Curb Stop	□ Benchmark
— G — G	Underground Gas Line	○ Hydrant	□ Asphalt Pavement
— T — T	Underground Telephone	○ Utility Valve	□ Concrete Pavement
— W — W	Water Main (Pipe Size)	○ Utility Meter	□ Proposed Building
— F — F	Fence - Steel	○ Utility Pole	□ Proposed Asphalt
— TR — TR	Treeline	○ Light Pole / Signal	□ Proposed Concrete
— C — C	Culvert	○ Guy Wire	□ Proposed Gravel
— 800 — 800	Index Contour - Existing	○ Electric Pedestal	
— 799 — 799	Intermediate Contour - Existing	○ Electric Transformer	
— 608 — 608	Proposed Storm Sewer	○ Air Conditioner	
— 608.73 — 608.73	Proposed Contour	○ Proposed Storm Manhole	
— 608.73 TW — 608.73	Proposed Swale	○ Proposed Curb Inlet	
— 608.73 TW + (608.7) — 608.73 TW + (608.7)	Proposed Culvert	○ Prop. Catch Basin / Yard Drain	
— 608.73 TW + (608.7) — 608.73 TW + (608.7)	Prop. Flowline Spot Elev.	○ Proposed Endwall	
— 608.73 TW + (608.7) — 608.73 TW + (608.7)	Prop. Top of Walk Elev.	○ Proposed Rip Rap	
— 608.73 TW + (608.7) — 608.73 TW + (608.7)	Existing Grade	○ Prop. Drainage Direction	
		○ Prop. Finished Floor Elev.	
		○ Emergency Overflow for Runoff	

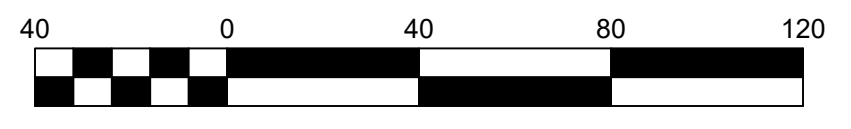

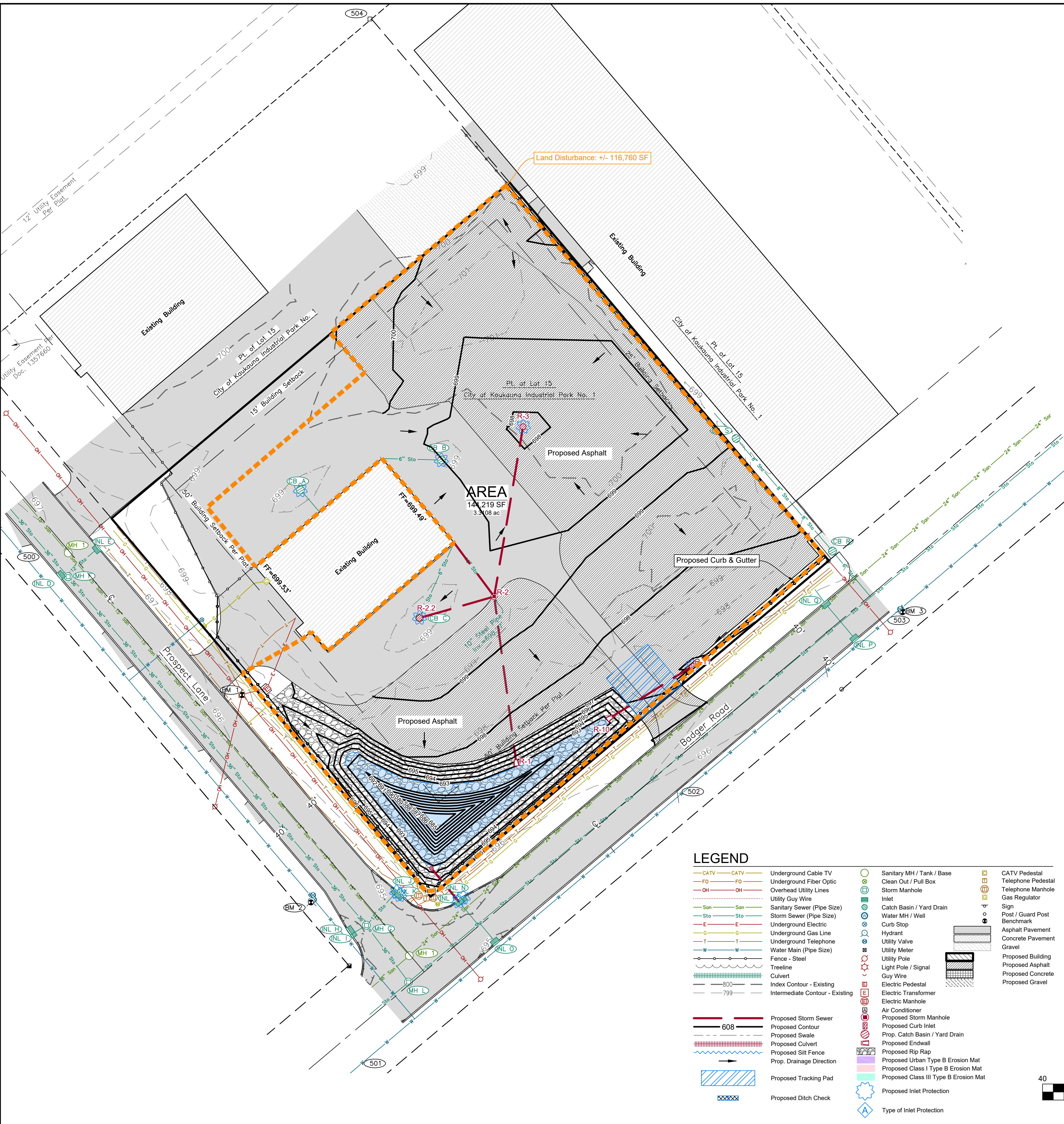

**LEGEND**

<ul style="list-style-type: none"> <li>— CATV</li> <li>— FO</li> <li>— OH</li> <li>— Utility Guy Wire</li> <li>— San</li> <li>— Sto</li> <li>— E</li> <li>— G</li> <li>— T</li> <li>— W</li> <li>— Fence - Steel</li> <li>— Trellis</li> <li>— 800</li> <li>— 799</li> <li>— Proposed Storm Sewer</li> <li>— Proposed Contour</li> <li>— Proposed Swale</li> <li>— Proposed Culvert</li> <li>— Proposed Silt Fence</li> <li>— Prop. Drainage Direction</li> <li>— Proposed Tracking Pad</li> <li>— Proposed Ditch Check</li> </ul>	<ul style="list-style-type: none"> <li>— CATV</li> <li>— FO</li> <li>— OH</li> <li>— Utility Guy Wire</li> <li>— San</li> <li>— Sto</li> <li>— E</li> <li>— G</li> <li>— T</li> <li>— W</li> <li>— Fence - Steel</li> <li>— Trellis</li> <li>— 800</li> <li>— 799</li> <li>— Proposed Storm Sewer</li> <li>— Proposed Contour</li> <li>— Proposed Swale</li> <li>— Proposed Culvert</li> <li>— Proposed Silt Fence</li> <li>— Prop. Drainage Direction</li> <li>— Proposed Tracking Pad</li> <li>— Proposed Ditch Check</li> </ul>	<ul style="list-style-type: none"> <li>○ Sanitary MH / Tank / Base</li> <li>○ Clean Out / Pull Box</li> <li>○ Storm Manhole</li> <li>○ Inlet</li> <li>○ Catch Basin / Yard Drain</li> <li>○ Water MH / Well</li> <li>○ Curb Stop</li> <li>○ Hydrant</li> <li>○ Utility Valve</li> <li>○ Utility Meter</li> <li>○ Utility Pole</li> <li>○ Light Pole / Signal</li> <li>○ Guy Wire</li> <li>○ Electric Pedestal</li> <li>○ Electric Transformer</li> <li>○ Electric Manhole</li> <li>○ Air Conditioner</li> <li>○ Proposed Storm Manhole</li> <li>○ Proposed Curb Inlet</li> <li>○ Prop. Catch Basin / Yard Drain</li> <li>○ Proposed Endwall</li> <li>○ Proposed Rip Rap</li> <li>○ Proposed Urban Type B Erosion Mat</li> <li>○ Proposed Class I Type B Erosion Mat</li> <li>○ Proposed Class III Type B Erosion Mat</li> <li>○ Proposed Inlet Protection</li> <li>○ Type of Inlet Protection</li> </ul>	<ul style="list-style-type: none"> <li>□ CATV Pedestal</li> <li>□ Telephone Pedestal</li> <li>□ Telephone Manhole</li> <li>□ Gas Regulator</li> <li>□ Sign</li> <li>□ Post / Guard Post</li> <li>□ Benchmark</li> <li>□ Asphalt Pavement</li> <li>□ Concrete Pavement</li> <li>□ Gravel</li> <li>□ Proposed Building</li> <li>□ Proposed Asphalt</li> <li>□ Proposed Concrete</li> <li>□ Proposed Gravel</li> </ul>
--	--	--	---

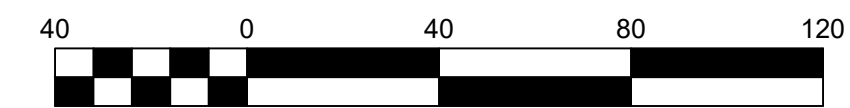

**Planned Sediment and Erosion Control Practices**  
 All erosion control practices shall be in place prior to disturbing the site. Post municipal and/or DNR Certificate of Permit Coverage onsite and maintain until construction activities have ceased and the site is stabilized. Keep a copy of the erosion control plan onsite throughout the duration of construction. All sediment and erosion control devices and methods shall be in accordance with DNR Technical Standards and the WisDOT Erosion Control Product Acceptability Lists (PAL). It is the responsibility of the Contractor to minimize the area disturbed and the duration of the disturbance. Erosion control measures shall be maintained on a continuing basis until the site is permanently stabilized. Erosion controls must be in place at the end of each work day with all off-site sediments being cleaned daily or as necessary. Sediment flushing is not allowed.

- 1) Diverting Flow
  - a) Permanent Diversion - Intended to divert runoff around disturbed areas to a location where the water can be discharged without adversely impacting the receiving area or channel. Permanent diversions will be used to route runoff to the swales, storm inlets, and public rights-of-way.
  - b) Overland Flow
    - a) Silt Fence - Intended to provide a temporary barrier to the transportation of sediment offsite. Silt fence also reduces the velocity of sheet flow; thereby reducing the erosion potential of flowing water. Silt fencing is not to be used in areas of channelized flow and sediment deposits shall be removed when a 6-inch depth is reached. The silt fence shall be repaired or replaced as necessary to maintain a barrier. All Silt Fence shall be installed and maintained in accordance with **DNR Technical Standard 1056**. It will be placed at the following locations:
      - along the site boundary where runoff will leave the site;
      - along a contour of similar elevation located downslope of a disturbed drainage area;
      - at the toe of soil piles if the pile will remain in place for more than seven (7) days.
    - b) Interim Manufactured Perimeter Control and Slope Interruption Products - Intended to detain or slow the flow of sediment-laden sheet flow runoff from small areas of disturbed soil, most commonly in the form of a sediment log. Sediment logs and other slope interruption products shall be installed and maintained in accordance with **DNR Technical Standard 1071**.
    - c) Temporary Grading Practices for Erosion Control - Intended to minimize erosion and sediment transport during grading operations on construction sites. Stage construction grading activities to minimize the cumulative exposed area. Conduct temporary grading for erosion control per **DNR Technical Standard 1067**.
    - d) Mulching and Erosion Mat - Intended to reduce the amount of erosion caused by raindrop impact, high overland and concentrated flow velocities, and assist the establishment of both temporary and permanent vegetation. All Erosion Mat shall be installed and maintained in accordance with **DNR Technical Standards 1052 and 1053** and all Mulching with **DNR Technical Standard 1058**. In addition to mulching, Erosion Mat is required per plan with installation per manufacturer specifications.
    - e) Seeding - Seeding will be used on all disturbed areas within seven days of the completion of the activity that will disturb the area. All seeding shall be in accordance with **DNR Technical Standard 1059**. Seed Mixture 30 (per WisDOT Specifications, Section 630) shall be applied at 5 pounds per 1,000 square feet for permanent seeding prior to September 15<sup>th</sup>. If required, temporary seeding shall consist of Oats, Rye, Winter Wheat, and/or Annual Ryegrass applied at rates and during the season specified by the Technical Standard, but no later than November 1<sup>st</sup>. Sod placement may occur at any time sod is available and the sod and soil are not frozen.
- 2) Trapping Sediment in Channelized Flow
  - a) Ditch Checks - Intended to settle suspended sediment in channelized flow by reducing the flow velocity. All Ditch Checks shall be installed and maintained in accordance with **DNR Technical Standard 1062**. Ditch Checks will be used where indicated on the plan as specified diameter sediment logs, or specified height stone or straw checks. Additional ditch checks may be required in areas where erosion is occurring.
- 3) Permanent Channel Stabilization
  - a) Armored Waterway - Intended to establish a non-erosive lining in the channel to prevent erosion. This can be accomplished using riprap. Riprap will be used in the following areas:
    - pipe outfalls as indicated on the plans
  - b) Vegetated Waterway - Intended to establish permanent vegetation to reduce the velocity of concentrated runoff thereby protecting the waterway from erosion. The type of erosion mat used will depend upon the velocity of the runoff in the channel and are specified in accordance with DOT Erosion Control Product Acceptability Lists (PAL). Vegetated waterways will be used in the following areas:
    - drainage swales as indicated on the plans
- 4) Inlet Protection Barriers - Intended to prevent the sedimentation of storm water conveyance structures. All Inlet Protection Barriers shall be installed and maintained in accordance with **DNR Technical Standard 1060**. As required, inlet protection barriers will be used at all storm sewer inlets as indicated on the plans. Type D-HR or D-M inlet protection shall be installed and maintained at all storm sewer surface inlets during construction.
- 5) Stone Tracking Pad - Intended to reduce the amount of sediment transported onto public roads. The Tracking Pad shall be installed and maintained in accordance with **DNR Technical Standard 1057**. A tracking pad will be constructed at the site entrance with daily maintenance to remove any sediment accumulation on the existing driveway.
- 6) Dust Control - Intended to reduce surface to air transport of dust during construction. Dust control shall be implemented with use of methods provided in **DNR Technical Standard 1068**. These methods include the use of polymers, seeding, and mulch.
- 7) Waste Material - All onsite waste and construction materials shall be handled and disposed of properly. No pavement material, runoff from concrete washout, or other waste material is allowed to enter the storm sewer system or receiving waters.

Refer to [https://dnr.wisconsin.gov/topic/Stormwater/standards/const\\_standards.html](https://dnr.wisconsin.gov/topic/Stormwater/standards/const_standards.html)

for copies of WDNR Stormwater Construction Technical Standards.  
**Sequence of Construction**  
 1) Obtain plan approval and other applicable permits.  
 2) Install all sediment control measures, strip topsoil. **August 2026**  
 3) Utility Construction: **August 2026**  
 4) Grade & Gravel parking and drive areas. Field inspect and add additional measures if necessary. **August 2026**  
 5) Asphalt Paving: **September 2026**  
 6) Establish vegetation (lawn and ditch areas) no later than one week after final grade is established. **No later than Month Day, Year, or immediately upon completion.**  
 7) Watering may be necessary to establish healthy and well rooted vegetation. Temporary measures shall be removed once final site stabilization has occurred (greater than 70-percent final vegetative cover).

Note: The dates provided are approximate for construction and subject to weather conditions and overall project schedule. Several work items as listed above may occur simultaneously with others.

**Maintenance Plan**  
 The contractor is responsible for inspection and maintenance of sediment and erosion control measures until the project is completed. The inspections shall be made every seven days or within 24-hours of a rainfall event of 0.50-inch or greater. Any practices that are damaged or not working properly shall be repaired by the end of the day. Accumulated sediment shall be removed when it has reached a height of one-half the height of the structure. In addition, the following measures shall be taken:

- 1) All seeded areas will be re-seeded and mulched as necessary according to the specifications in the planned practices to maintain a vigorous, dense vegetated cover.
- 2) Remove silt fence and temporary structures only after final stabilization and vegetative cover is established.
- 3) Avoid the use of fertilizers and pesticides in or adjacent to channels or ditches.
- 4) Construction and waste materials shall be properly disposed.

Weekly inspection reports shall be maintained by the contractor. These reports shall document inspections and maintenance performed. The date and time of the inspections, the inspector's name, and the status of construction and any maintenance performed. Refer to <http://dnr.wi.gov/topic/stormwater/construction/forms.html> for a template. Upon request, the inspection reports shall be made available to the owner, the engineer, City of Kaukauna, or the Wisconsin Department of Natural Resources.

**Responsible Parties**  
 Best Management Practices (BMPs) Construction and Maintenance:  
 To be determined  
 Inspection and Compliance Enforcement  
 City of Kaukauna  
 Wisconsin Department of Natural Resources

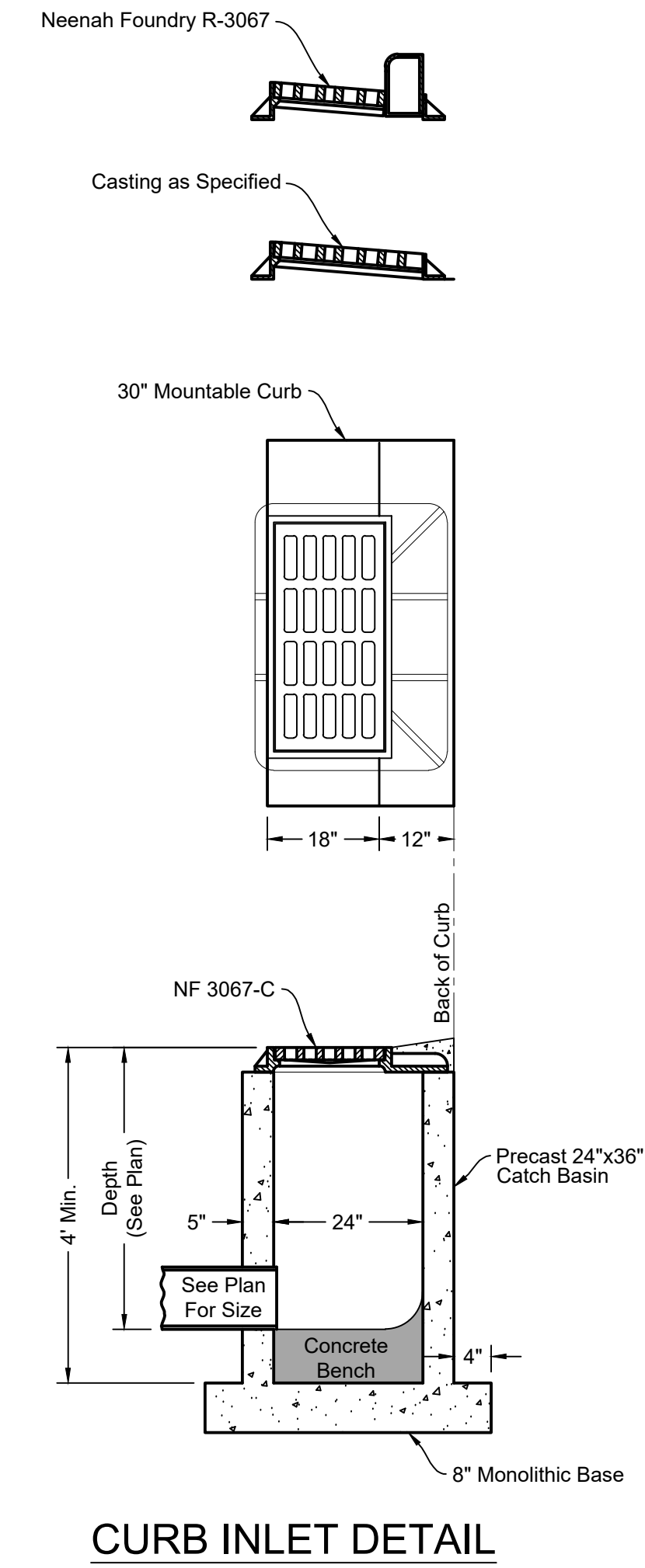
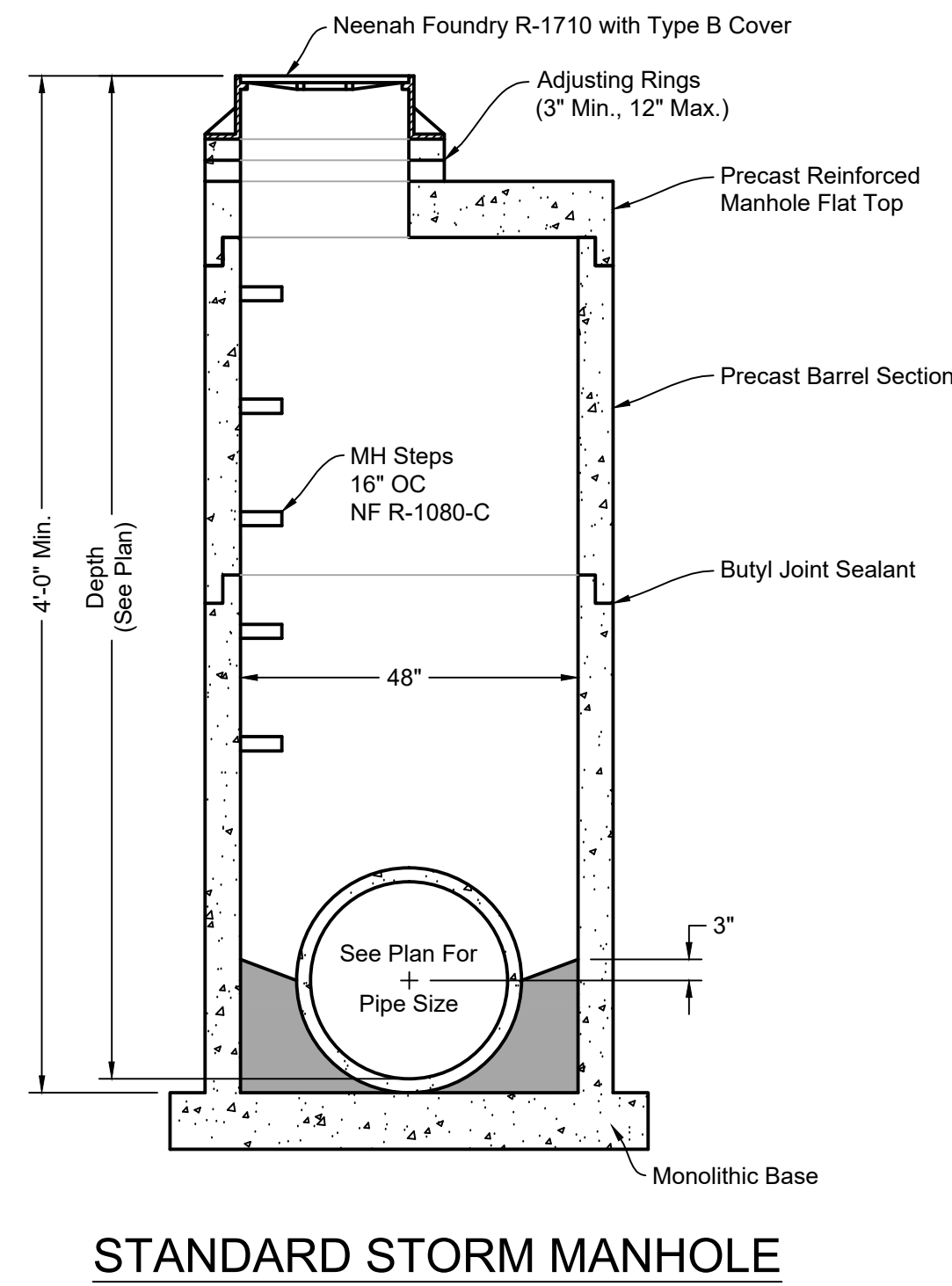
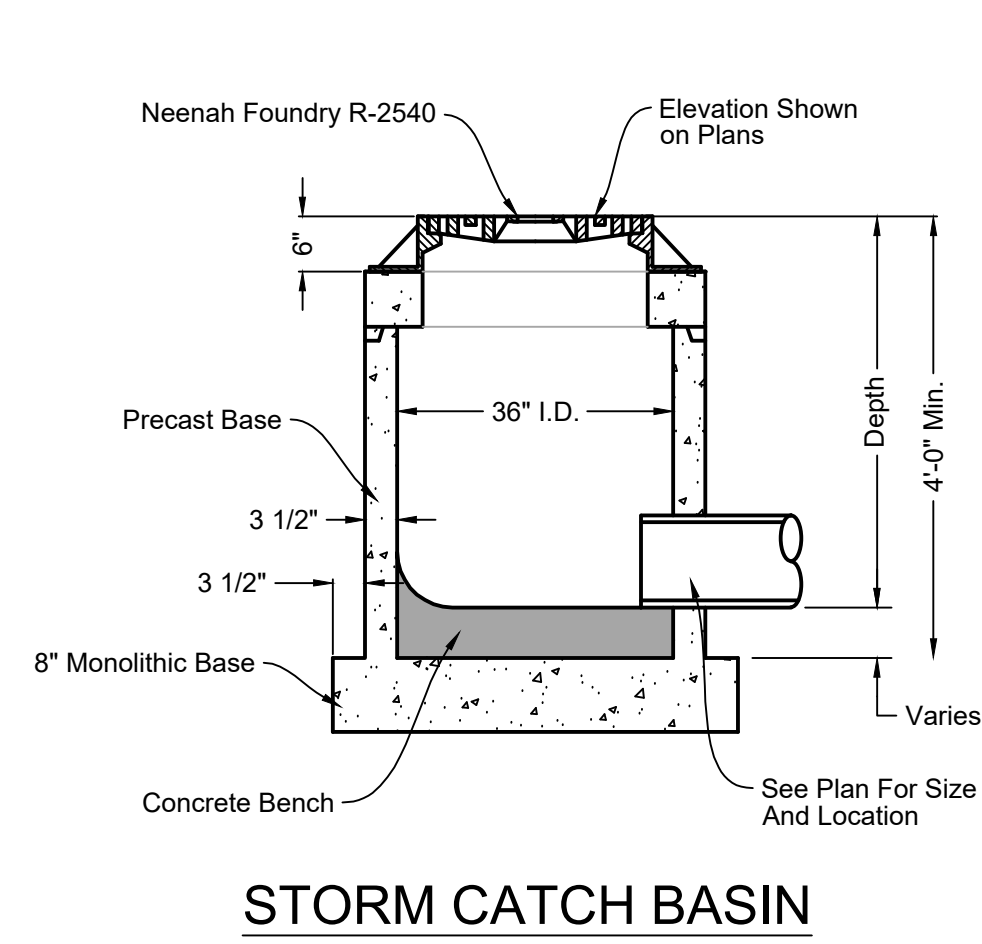
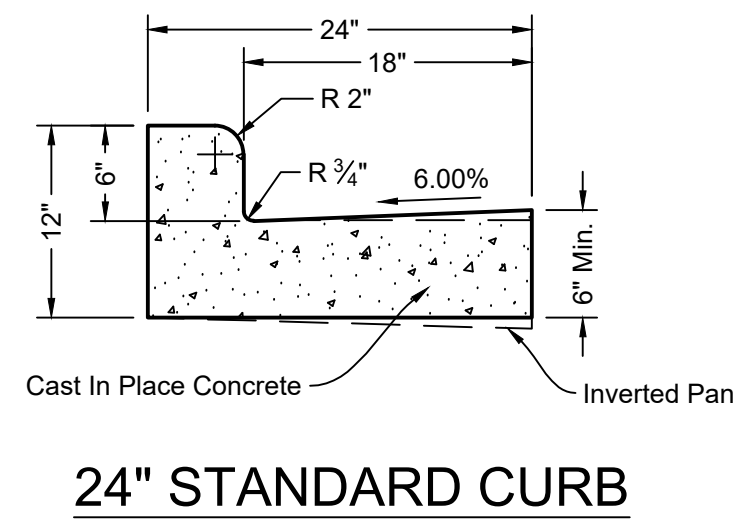
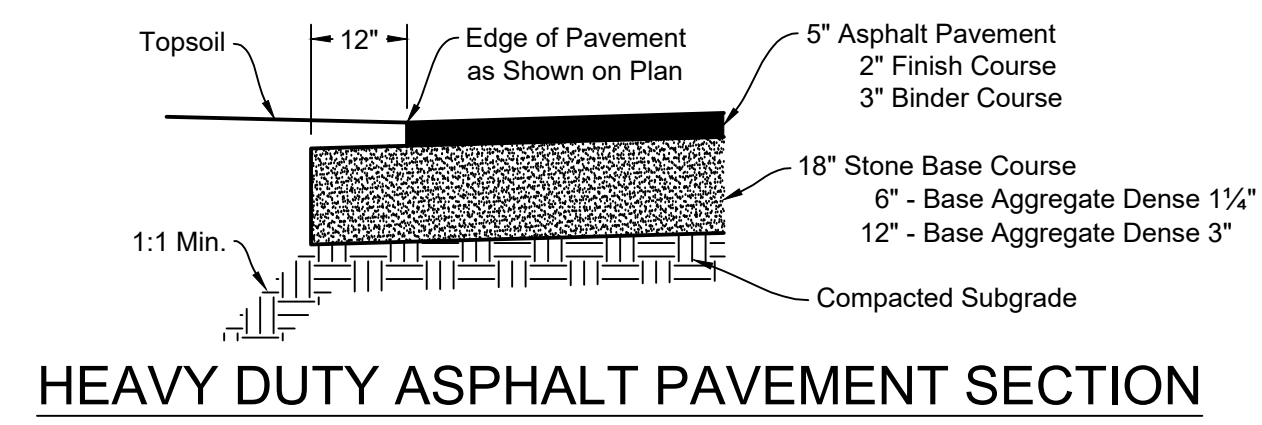

**CONSTRUCTION DETAILS**

1020 Prospect Lane  
 City of Kaukauna, Outagamie County, WI  
 For: Team Industries, Inc.

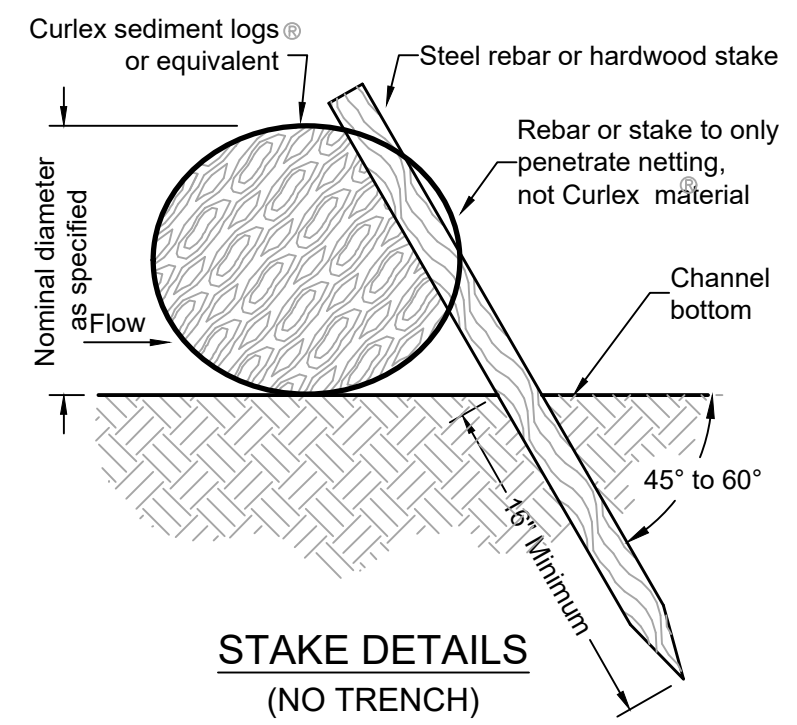

**STAKE DETAILS**  
(NO TRENCH)

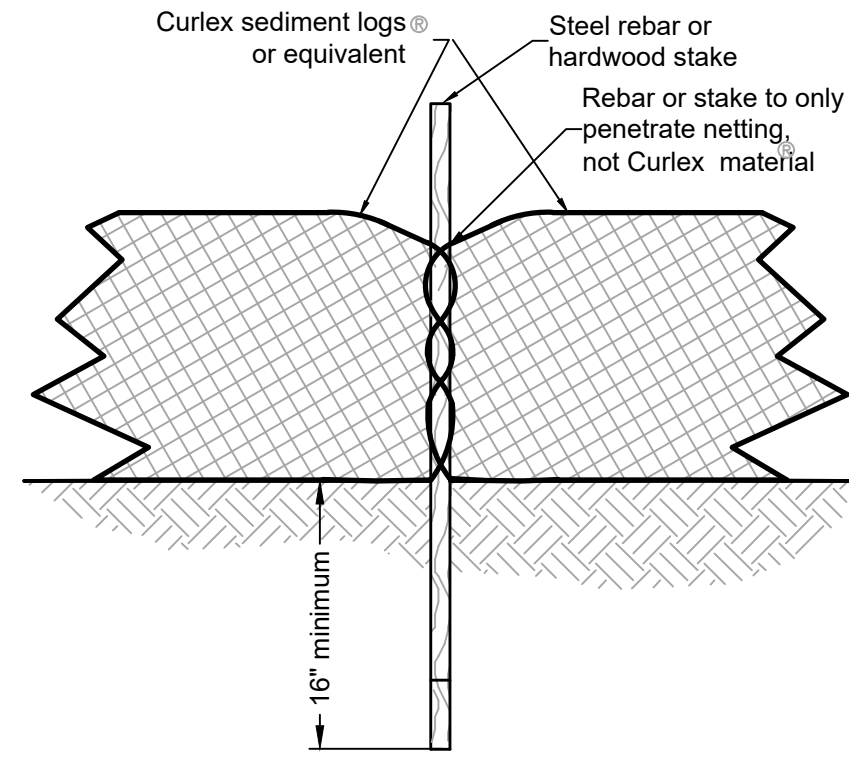

**STAKE DETAIL**  
(FRONT VIEW)

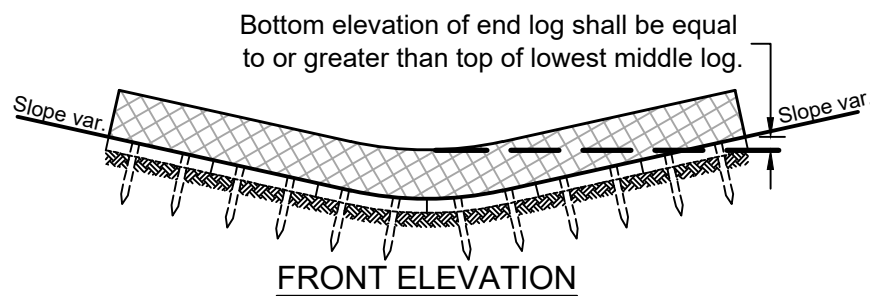

**FRONT ELEVATION**

**NOTE:**  
Stake installation shall meet manufacturer's requirements in regard to spacing, material, size, and bury depth.

**SEDIMENT LOG DETAIL**

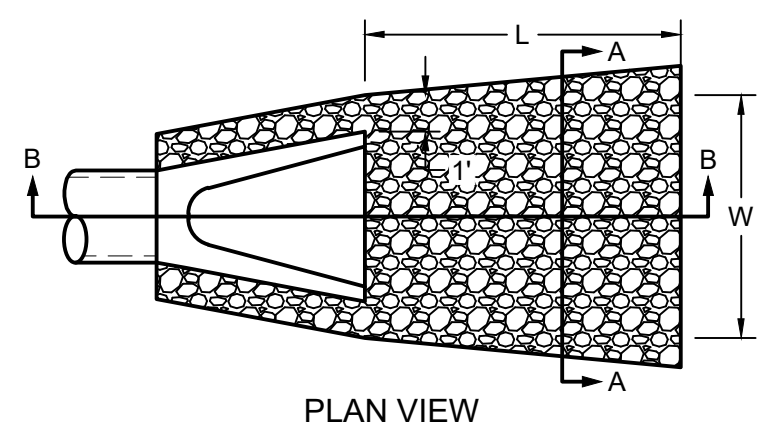

**PLAN VIEW**

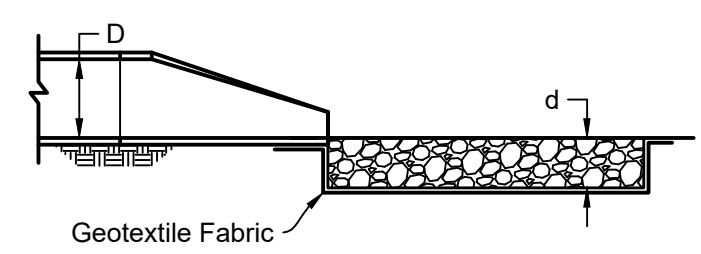

**SECTION B-B**

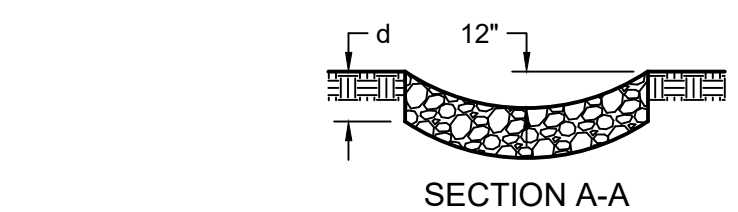

**SECTION A-A**

D	12"	15"	18"	21"	24"	30"	36"	42"	48"	54"	60"
L	10'	12'	18'	20'	20'	25'	28'	33'	37'	40'	45'
W	11'	13'	20'	22'	24'	28'	32'	38'	42'	45'	50'
d	12"	12"	12"	16"	18"	18"	24"	24"	24"	24"	24"
Riprap cu yds	2.6	3.6	7.8	14.3	15.6	22.8	38.4	53.2	65.8	76.3	95.0

- Notes:**
- Excavate below channel outlet and widen channel outlet to the required riprap thickness for each apron. Foundation to be set to zero grade and smoothed.
  - Place geotextile fabric on bottom and sides of prepared foundation. Fabric shall extend under endwall in accordance with DOT specifications. (DOT Section 628.2 & 628.3)
  - Exercise care in placement of riprap to avoid damage to filter fabric.
  - Use riprap conforming to Wisconsin DOT specifications. (DOT Section 606.2 & 606.3)
  - Use DOT Type R geotextile fabric for light riprap. Use Type HR for medium and heavy riprap. (DOT Section 606.2, 606.3, 628.2 & 628.3)
  - Use 12" dimension for pipes less than 12" in diameter.

**OUTLET PROTECTION**

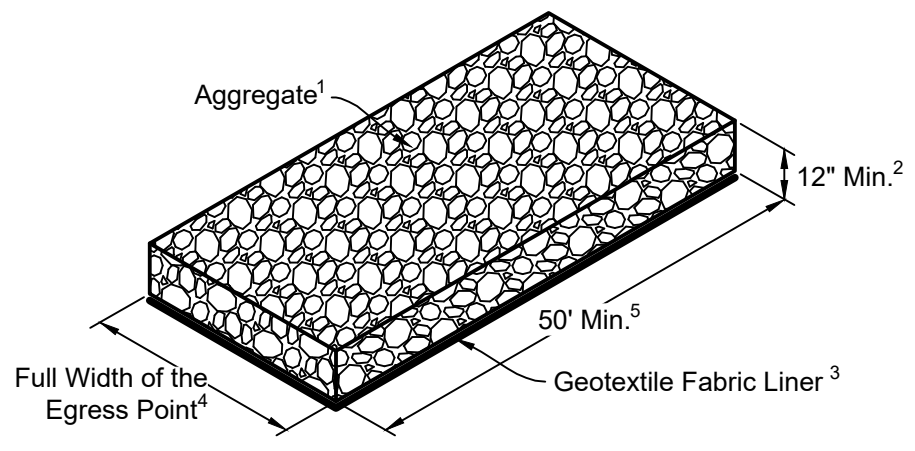

**TRACKING PAD DETAIL**  
DNR TECHNICAL STANDARD 1057

- Note 1** Use hard, durable, angular stone or recycled concrete meeting the gradation in Table 1. Where this gradation is not available, meet the gradation in Wisconsin Department of Transportation (DOT) 2022 Standard Specification, Section 312, Select Crushed Material.
- Note 2** Slope the stone tracking pad in a manner to direct runoff to an approved treatment practice.
- Note 3** Select fabric type based on soil conditions and vehicles loading.
- Note 4** Install tracking pad across full width of the access point, or restrict existing traffic to a dedicated egress lane at least 12 feet wide across the top of the pad.
- Note 5** If a 50' pad length is not possible due to site geometry, install the maximum length practicable and supplement with additional practices as needed.

**TABLE 1: GRADATION FOR STONE TRACKING PADS**

Sieve Size	Percent by weight passing
3"	100
2-1/2"	90-100
1-1/2"	25-60
3/4"	0-20
3/8"	0-5

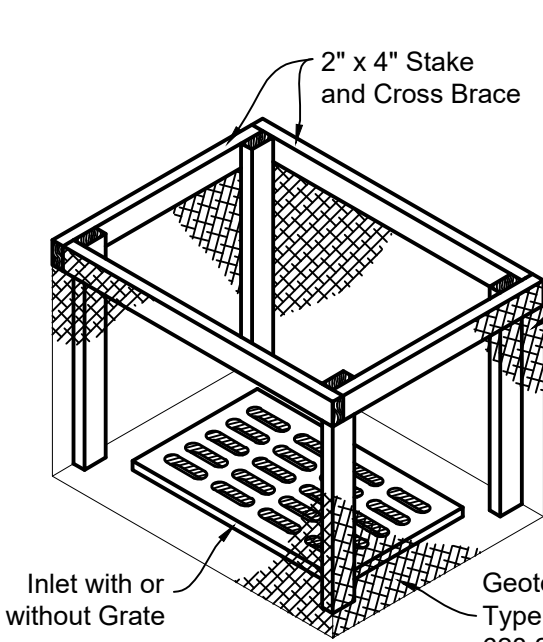

**INLET PROTECTION, TYPE A**

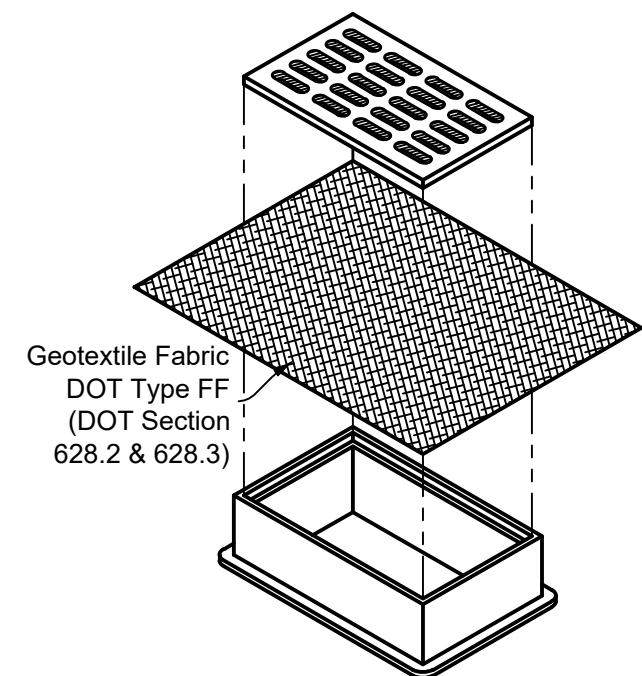

**INLET PROTECTION, TYPE B**  
(CAN BE INSTALLED IN ANY INLET WITHOUT A CURB BOX)

**GENERAL NOTES:**  
Inlet protection devices shall be maintained or replaced at the direction of the engineer.  
Manufactured alternatives approved and listed on the DOT Erosion Control Product Acceptability list may be substituted.

- When removing or maintaining inlet protection, care shall be taken so that the sediment trapped on the geotextile fabric does not fall into the inlet. Any material falling into the inlet shall be removed immediately.
- Finished size, including flap pockets where required, shall extend a minimum of 10" around the perimeter to facilitate maintenance or removal.
  - For inlet protection, Type C (with curb box), an additional 10" of fabric is wrapped around the wood and secured with staples. The wood shall not block the entire height of the curb box opening.
  - Flap pockets shall be large enough to accept wood 2x4.

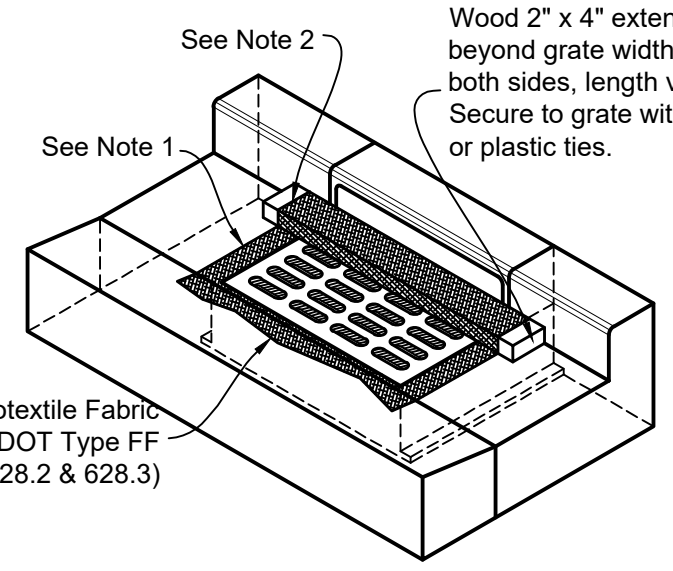

**INLET PROTECTION, TYPE C**

**INSTALLATION NOTES:**  
Inlet protection Type A shall be utilized around field inlets until permanent stabilization methods have been established. Inlet protection Type A shall be utilized on pavement inlets prior to installation of curb and gutter or pavement.  
Inlet protection Type B shall be utilized on street inlets without curb heads, once surrounding surface is in place.  
Inlet protection Type C shall be utilized on street inlets with curb heads.

**TYPE B & C**  
Trim excess fabric in the flow line to within 3" of the grate.  
The contractor shall demonstrate a method of maintenance, using a sewn flap, hand holds, or other method to prevent accumulated sediment from entering the inlet.

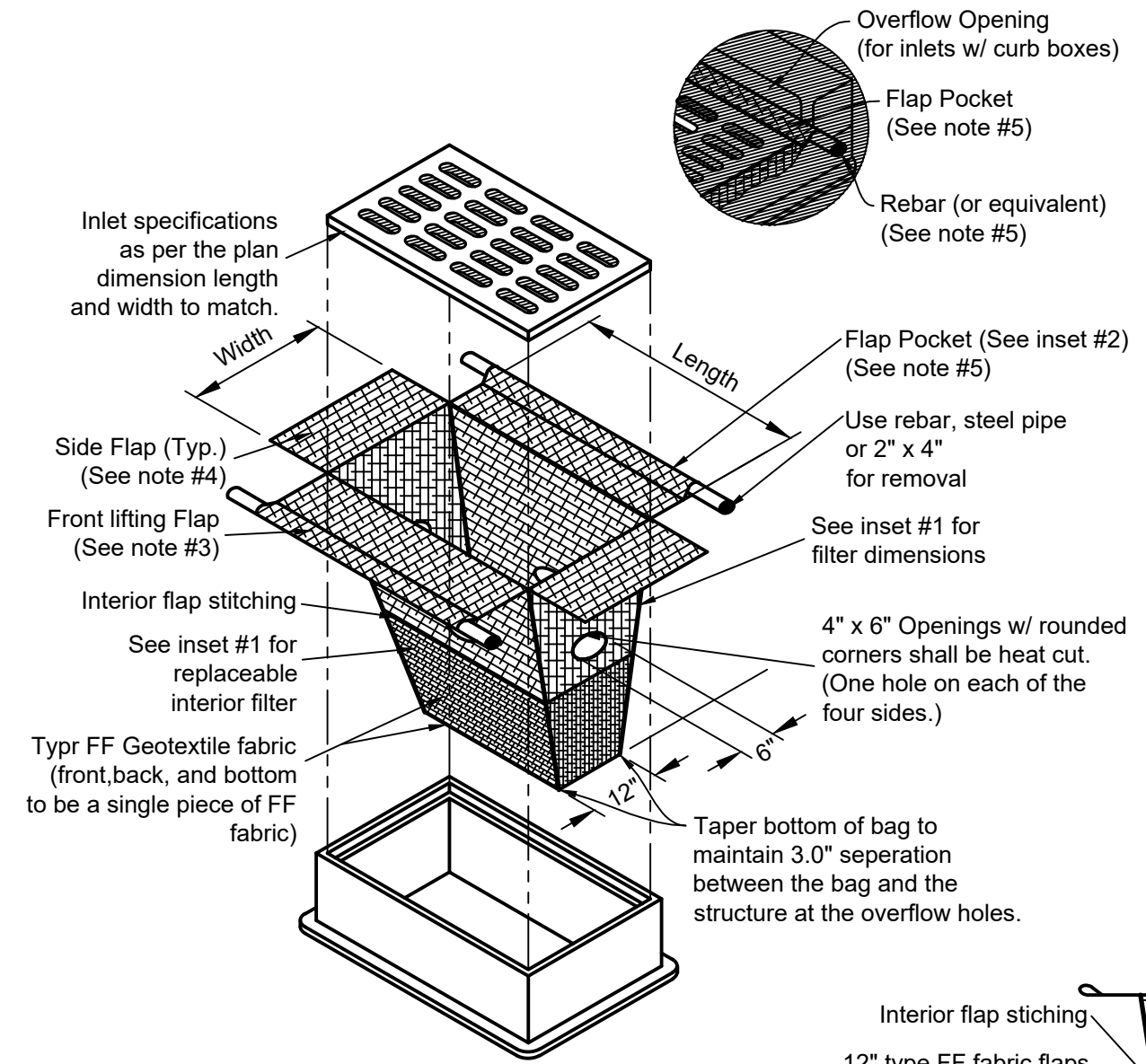

**INLET PROTECTION, TYPE D-M**  
(CAN BE INSTALLED IN ANY INLET WITH OR WITHOUT A CURB BOX)

- NOTES:**
- Taper bottom of bag to maintain three inches of clearance between the bag and the structure, measured from the bottom of the overflow openings to the structure wall.
  - Geotextile fabric, Type FF for flaps, top and bottom of outside of filter bag. Front, back and bottom of filter bag being one piece.
  - Front lifting flap is to be used when removing and maintaining filter bag.
  - Side flaps shall be a maximum of two inches long. Fold the fabric over and reinforce with multiple stitches.
  - Flap pockets shall be large enough to accept wood 2" x 4". The rebar, steel pipe, or wood shall be installed in the rear flap and shall not block the top half of the curb face opening.
- MAINTENANCE NOTES:**
- When removing or maintaining inlet protection, care shall be taken so that the sediment trapped in the fabric does not fall into the structure. Material that has fallen into the inlet shall be immediately removed.

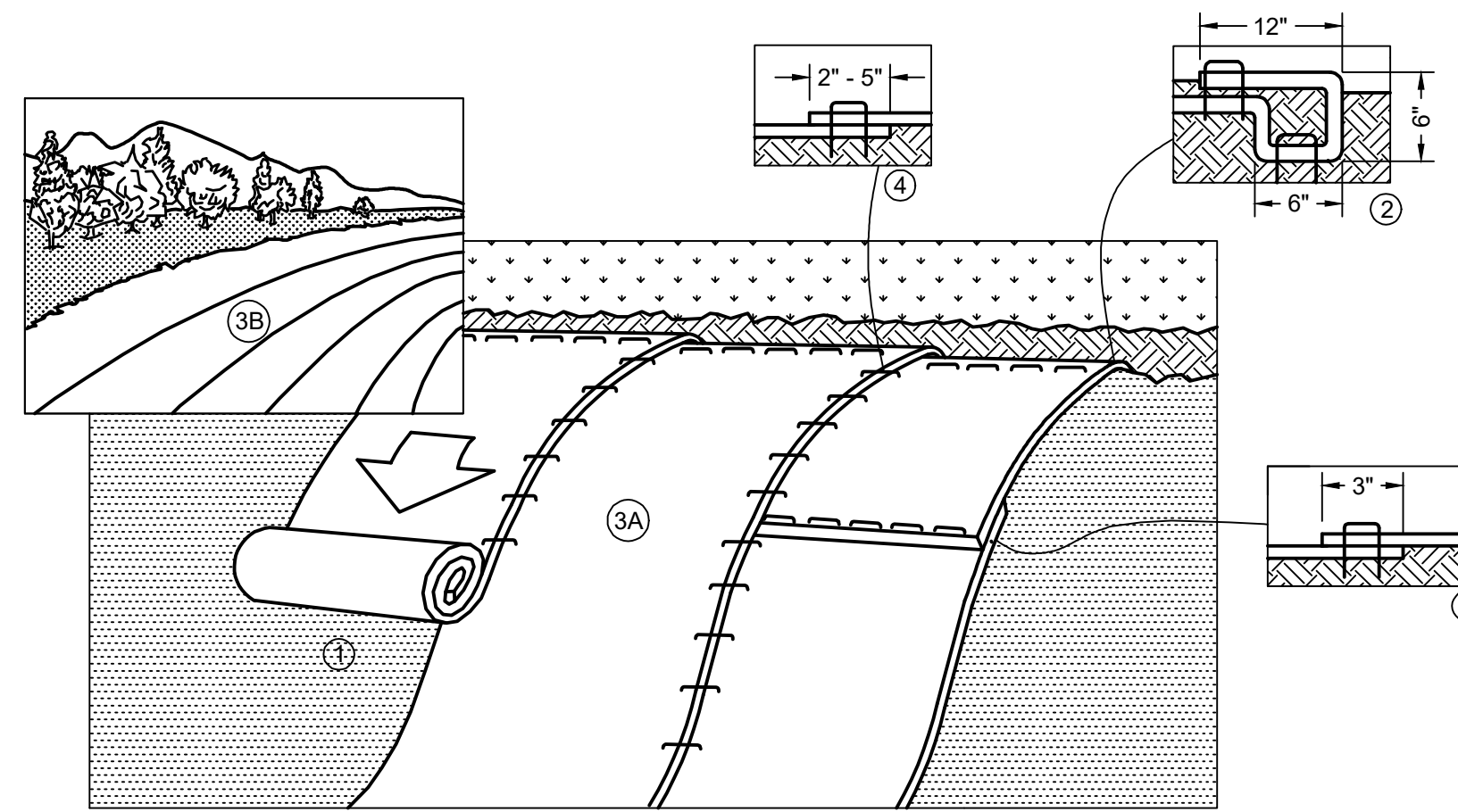

- Prepare soil before installing Rolled Erosion Control Products (RECP's), including any necessary application of lime, fertilizer, and seed.  
**Note:** When using cell-o-seed do not seed prepared area. Cell-o-seed must be installed with paper side down.
- Begin at the top of the slope by anchoring the RECP's in a 6" (15 cm) deep x 6" (15 cm) wide trench with approximately 12" (30 cm) of RECP's extended beyond the up-slope portion of the trench. Anchor the RECP's with a row of staples/stakes approximately 12" (30 cm) apart in the bottom of the trench. Backfill and compact the trench after stapling. Apply seed to compacted soil and fold remaining 12" (30 cm) portion of RECP's back over seed and compacted soil. Secure RECP's over compacted soil with a row of staples/stakes spaced approximately 12" (30 cm) apart across the width of the RECP's.
- Roll the RECP's (A.) down or (B.) horizontally across the slope. RECP's will unroll with appropriate side against the soil surface. All RECP's must be securely fastened to soil surface by placing staples/stakes in appropriate locations as shown in the staple pattern guide. When using the Dot system, staples/stakes should be placed through each of the colored Dots corresponding to the appropriate staple pattern.
- The edges of parallel RECP's must be stapled to approximately 2" - 5" (5 cm - 12.5 cm) overlap depending on RECP's type.
- Consecutive RECP's spliced down the slope must be placed end over end (shingle style) with an approximate 3" (7.5 cm) overlap. Staple through overlapped area, approximately 12" (30 cm) apart across entire RECP's width.  
**Note:** \* In loose soil conditions, the use of staple or stake lengths greater than 6" (30 cm) may be necessary to properly secure the RECP's.
- Detail provided by North American Green ([www.nagreen.com](http://www.nagreen.com))
- Turf Reinforcement Mats (TRM's) shall be installed in accordance with the above specifications for all RECP's. Anchoring size and pattern is to be installed per manufacturer specifications for clay soils having 4:1 slope. All TRM's shall be topsoil filled, seeded, and covered with a Class 2, Type B erosion mat in accordance with all manufacturer specifications.

**EROSION/TURF REINFORCEMENT MAT SLOPE INSTALLATION**

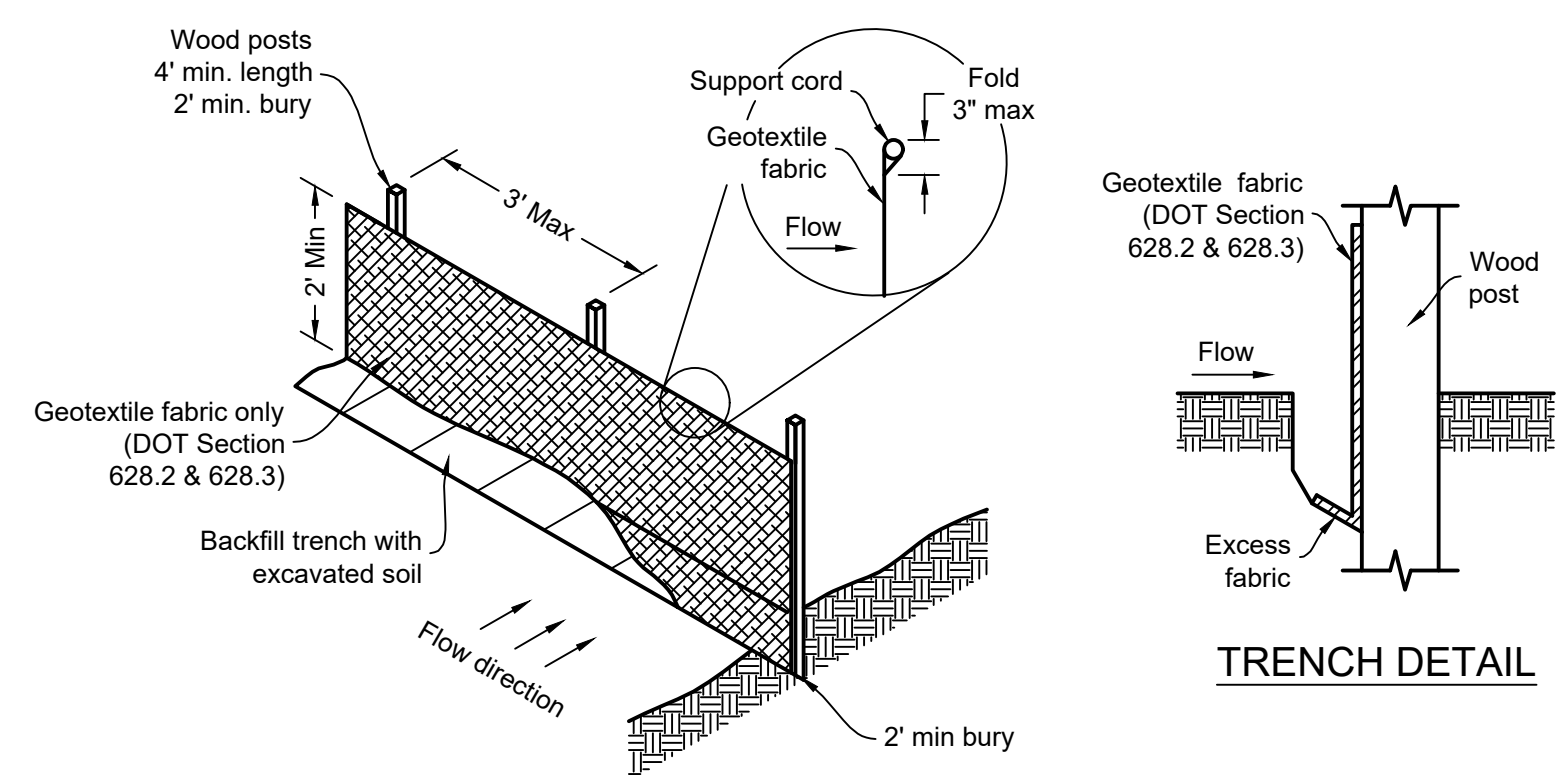

- Silt fence notes:**
- Detail of construction not shown on this drawings shall conform to criteria set by authorities having jurisdiction and by DNR Technical Standard 1056.
  - When possible, the silt fence should be constructed in an arc or horseshoe shape with the ends pointing upslope to maximize both strength and effectiveness.
  - Attach the fabric to the posts with wire staples or wooden lath and nails.
  - 8'-0" post spacing allowed if a woven geotextile fabric is used.
  - Trench shall be a minimum of 4" wide and 6" deep to bury and anchor the geotextile fabric. Fold material to fit trench and backfill and compact trench with excavated soil.
  - Geotextile fabric shall be reinforced with an industrial polypropylene netting with a maximum mesh spacing of 3/4" or equal. A heavy-duty nylon top support chord or equivalent is required.
  - Steel posts shall be studded "tee" or "u" type with a minimum weight of 128 lbs/lineal foot (without anchor). Fin anchors shall be a minimum size of 4" diameter or 1 1/2" x 3 1/2", except wood posts for geotextile fabric reinforced with netting shall be a minimum size of 1 1/8" x 1 1/8" oak or hickory.

**SILT FENCE INSTALLATION**

**CONSTRUCTION DETAILS**

