

Maple Farms Plan of Development

Submitted to:

The City of Iowa Colony

July 2024

Prepared for:

Maple Development Group

Prepared by:



TABLE OF CONTENTS

I. INTRODUCTION

A. Summary	5
B. Purpose of the Amendment	5
C. Project Location	5
D. Surrounding Land Use	5
E. Existing Site Conditions	5

II. DEVELOPMENT PLAN

A. Purpose & Intent	8
B. Goals & Objectives	8
1. Establish a Strong Community Character & Sense of Place	8
2. Provide a Variety of Housing Types	8
3. Ensure Quality Development	8
4. Provide for Orderly Growth	9
C. Zoning/Land Use Plan	9
1. Proposed Uses & Densities	9
D. Benefits to the Iowa Colony	12
E. Transportation	14
1. Existing Access	14
2. Street Hierarchy	14
3. Minimum Right-of-Way & Paving Sections	15
4. Street Design Criteria	15
5. Street Sidewalks	18
6. Traffic Signalization	19
F. Parks, Open Space & Trails	20
1. Parks & Open Space	20
2. Trails	21
3. Tree Preservation	21
G. Infrastructure	23
1. Municipal Utility Districts	23
2. Water	23
3. Wastewater	23
4. Storm Drainage & Detention System	23
5. Flood Plain Management	23
6. Other Utilities	23
7. Schools	23
8. Homeowner's Association	24

Plan of Development

III. DEVELOPMENT REGULATIONS

A. Purpose & Intent	26
B. General Provisions	26
1. Applicability	26
2. Additional Uses	26
3. Non-Conforming Land Uses	26
4. Non-Conforming Structures	26
5. Existing Utilities	26
6. Drill Sites	26
7. General Development Plan	27
8. Mass Grading & Construction of Detention	28
9. Temporary Uses	28
10. Design Guidelines	30
11. Lighting	30
12. Screening and Fencing	30
13. Architectural Standards	30
C. Development Standards	30
1. Traditional Single Family- Type I	30
2. Traditional Single Family- Type II	32
3. Traditional Single Family- Type III	33
4. Patio Home	34
5. Townhome	36
6. Quads	37
7. Alley Product	38
8. Multi-Family	39
9. Commercial	41
10. Institutional	45
11. Mixed-use	46
12. Parks & Open Space	47
13. Parking	49
D. Definitions	51

IV. GENERAL ADMINISTRATION & AMENDMENTS

A. Purpose	56
B. Changes to Code of Ordinance	56
C. Variances to the Subdivision Ordinance, Unified Development Code, and Zoning Ordinance	56
D. Variances from the Design Manual	56
E. Interpretation	66
F. Administrative Approval	66
G. Substantial Change	67
H. Fees	67
I. Sales Tax Sourcing	67

Maple
Farms

The City of Iowa Colony

Plan of Development

J. Noncompliance

67

K. Expiration

67

EXHIBITS

Exhibit 1 Ownership Map

6

Exhibit 2 Jurisdictional Map

7

Exhibit 3 Preliminary Land Use Plan

13

Exhibit 4 Parks, Open Space, & Trails Plan

22

Exhibit 5 Phasing Map

25

TABLES

Table 1 Minimum Right-of-Way Width & Paving Section

15

Table 2 Sidewalk Requirements

19

Table 3 Parking Requirements

49

Table 4 Shared Parking Table

50

Table 5 Subdivision Ordinance Variances

57

Table 6 Unified Development Code Variances

62

Table 7 Zoning Ordinance Variance

62

Table 8 Design Manual Variances

64

Plan of Development

I. INTRODUCTION

A. Summary

The Planned Unit Development District establishes comprehensive guidance and regulations for the Maple Farms project (the “Project”). The Project is comprised of approximately 900 acres of privately owned land that is partially within unincorporated Brazoria County and the extraterritorial jurisdictions (ETJ) of the City of Sandy Point and the City of Alvin, and is directly adjacent to the corporate limits of the City of Iowa Colony, with the intent of annexation into the City of Iowa Colony (the “City”).

The intent of this document is to provide a means by which development may occur in an orderly and responsible manner by establishing guidelines that ensure quality development and specifically address the goals of both the city and the developer.

B. Purpose of the Project

The Project will create a cohesive community atmosphere that will compliment and bring to life the City of Iowa Colony’s vision for the future of Iowa Colony. In planning this development, the developer reached out to the City for its goals for Iowa Colony and regionalization. The guidelines within this document will create regulations that will ensure the quality and character desired by both the City and the developer.

C. Project Location

The Project Property is located generally west of State Highway 288 and in Brazoria County, south of the metro Houston area, between FM 53 on the north and FM 521 on the west. The Grand Parkway (TX-99) is proposed to bisect the Property at the northeast corner. Future CR 55 will extend from north to south through the Project.

D. Surrounding Land Use

The majority of properties surrounding the Project Property are undeveloped with some existing large lot single family development in nearby areas.

F. Existing Site Conditions

The existing character of the property is primarily agricultural land and open pastureland. A significant amount of the tract will be retained for open space, drainage, and mitigation areas as the Project is developed.

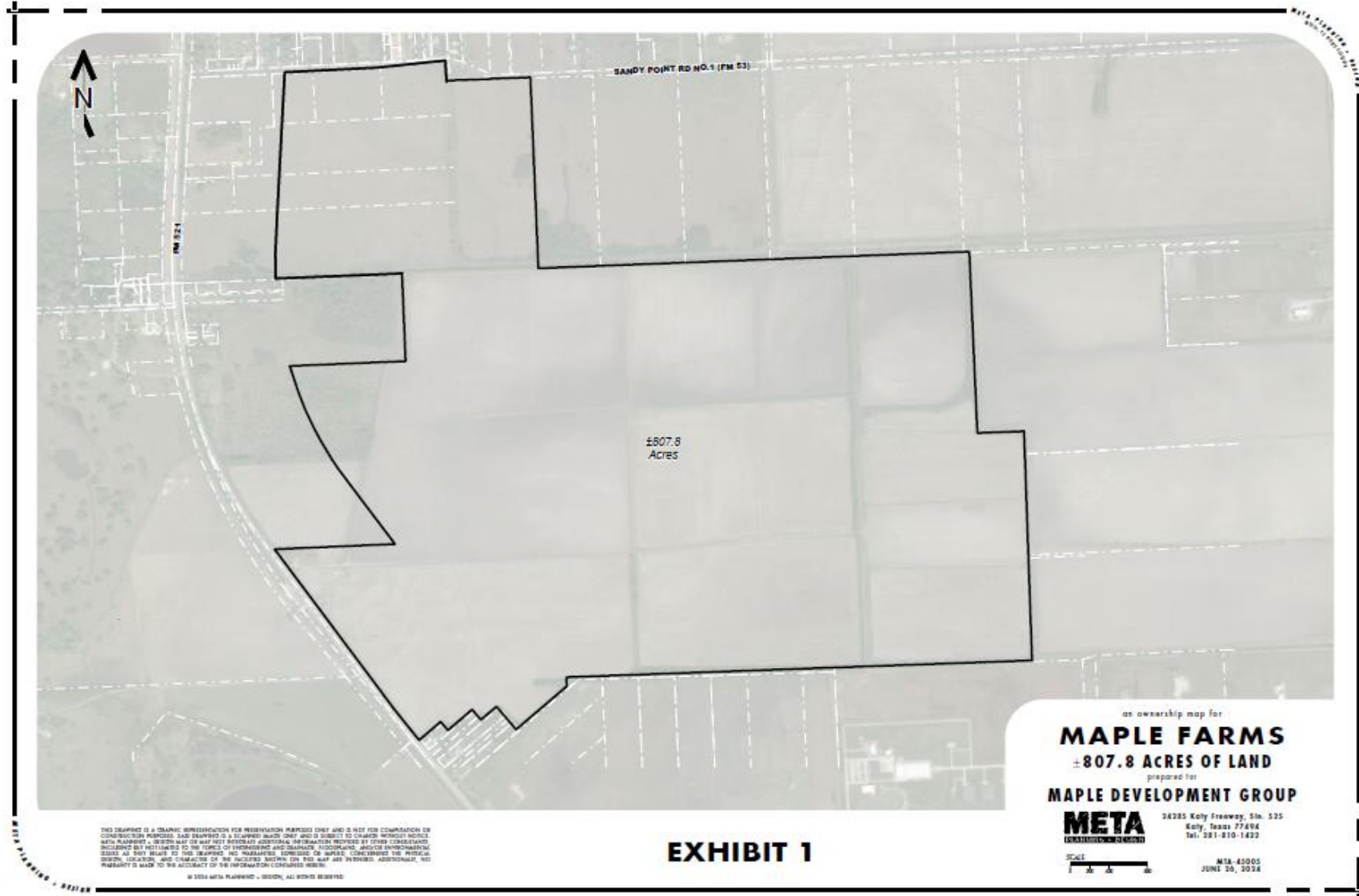

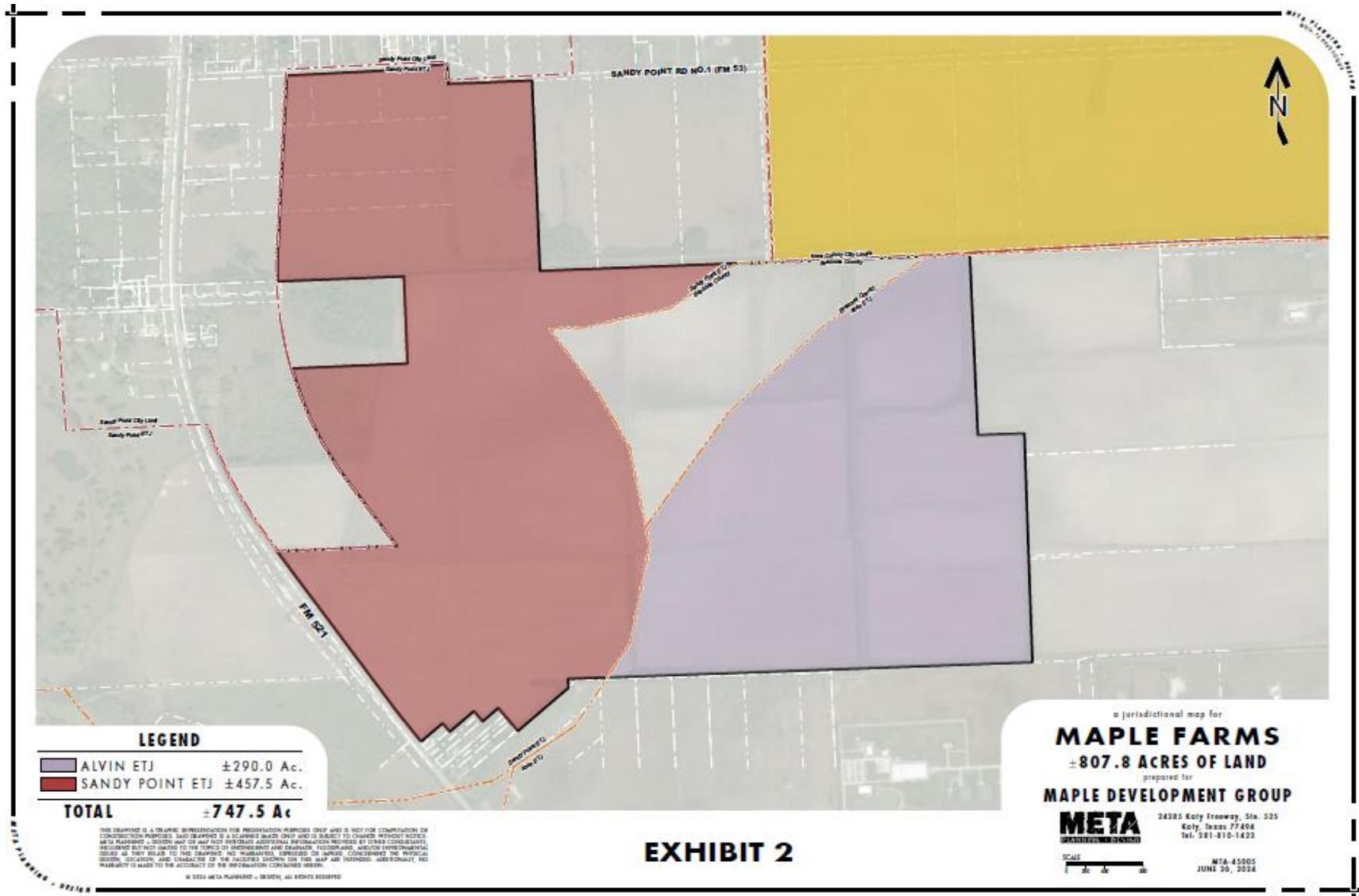

II. DEVELOPMENT PLAN

A. Purpose & Intent

The purpose of the Development Plan is to clarify planning considerations within the plan area and guide the implementation of the vision for the community. It will also establish a framework for the Project by identifying the type, general location, and projected density of the various land uses proposed within the development.

This document describes the goals, objectives, and policies of the Plan of Development, and it clearly illustrates the design principles of the community.

B. Goals & Objectives

The main goal of the Planned Unit Development District is to create a master planned community that features a mixture of uses and a variety of housing types that will encourage attractive and sustainable neighborhoods and attract investment to the area while preserving the existing natural environment.

Key objectives have been established in order to guide development and provide direction for the overall vision of the community. These objectives are as follows:

1. Establish a Strong Community Character

A strong community character will be created by the extensive open space system which will offer neighborhood connectivity within the community as well as access to daily activities, thus reducing dependency on vehicular travel and preserving the rural character of the area.

Strategically located public gathering areas will encourage community activities and enhance the City Council's vision for Iowa Colony's quality of life. A focus on the concept of wellness will be a guiding principle for development.

In addition, the implementation of a community theming plan will establish a strong sense of place by assuring design and visual continuity throughout the community.

2. Provide a Variety of Housing Types

Providing variation of housing types will create a community that attracts individuals from all stages of life. The establishment of this well-balanced population base is critical to the long-term sustainability of the Project and will enhance the social and economic base of the community and compliment all of Iowa Colony.

3. Ensure Quality Development

The Project will ensure the quality of development through the establishment of design guidelines for the community that regulate architectural standards, landscaping, signage, and other common elements of the development.

Plan of Development

4. Provide for Orderly Growth

The Project will provide for orderly growth by being sensitive to the natural features of the site and selecting land uses that are appropriate based on site characteristics.

Buffering between different land uses will be achieved by parks, greenbelts, landscaping, streets, open space, or drainage features.

In addition, the Project will help the City achieve a highly efficient and cohesive public infrastructure system to better serve Iowa Colony.

C. Zoning/Land Use Plan

1. Proposed Uses & Densities

Successful master planned communities provide a variety of uses and housing options in order to attract residents from all stages of life. The proposed land uses will help to achieve a variety of housing choices in order to create a sustainable community while allowing for a reasonable amount of flexibility to accommodate ever-changing market demands.

To implement the conceptual land use plan, the Project will be designated a Planned Unit Development. The land uses within the Planned Unit Development will consist of Traditional Single-Family Residential (TSFR), Patio Home (PH), Townhome (TH), Quads (Q), Alley Products (AP), Multi-Family (MF), Commercial (C), Institutional (I), Mixed-Use (MU), and Parks & Open Space (POS). The various land uses will follow the development requirements for their assigned zoning districts as described in the Zoning Ordinance as of the Effective Date unless otherwise noted throughout this Plan of Development. The land uses may be relocated within the boundaries of the Plan of Development as necessary to address economic and market conditions or future modifications of roadway and drainage alignments. The following is a brief description of these proposed uses.

Traditional Single Family Residential - The Traditional Single-Family Residential category (TSFR) is intended for the development of detached, single family dwelling units. Lot sizes within the Traditional Single-Family Residential category are intended to range in size from 40-foot-wide lots to 70-foot-wide lots or larger with a minimum lot area of 4,600 square feet. Traditional single-family residential will be broken into three categories:

Type I: Type I traditional single-family residential lots will have a minimum lot width of 60-feet and a minimum square footage of 6,600. Typical 60' lots or wider would be encompassed in this residential type.

Type II: Type II traditional single-family residential lots will have a minimum lot width of 50-feet and a minimum square footage of 6,000. Typical 50' and 55' lots would be encompassed in this residential type.

Type III: Type III traditional single-family residential lots will have a minimum lot width of 40-feet and a minimum square footage of 4,600. Typical 40' and 45' lots would be encompassed in this residential type.

Specialty product:

Patio Home – The Patio Home category (PH) provides for the development of single-family dwelling units. Patio homes may have a zero (0) foot side setback on one of the interior lot lines or five (5) feet side setbacks on both sides at the discretion of the developer, but all homes shall be separated by a minimum of ten (10) feet. Patio homes shall have a minimum lot width of 40 feet and a minimum lot area of 4,400 square feet.

Townhome – The Townhome category (TH) provides for the development of attached, single family dwelling units separated by a fire rated wall. Each of the buildings is expected to consist of a minimum of two (2) units with a maximum of eight (8) units and shall be separated by a minimum of ten (10) feet between structures. Each townhome unit shall be platted on an individual lot and shall have a minimum lot width of 22 feet and a minimum lot area of 2,200 square feet.

Quads – The Quads category (Q) provides for the development of four (4) single-family dwelling units taking access from a shared drive. Each lot shall have street frontage, some of which may consist of flag lots overlapping the shared drive. Each lot within a quad shall have a minimum lot area of 3,500 square feet and the four-pack shall have a minimum width of 120 feet.

Alley Product – The Alley Product category (AP) provides for the development of single-family dwellings. The Alley Products may have street frontage and/or alley frontage taking garage access from the alley. Each Alley Product shall have a minimum lot area of 4,400 square feet and a minimum lot width of 42 feet.

Parks & Open Space – The Parks & Open Space category (P-OS) is intended to provide for the development of recreation and open space areas within the community.

Multi-Family – The Multi-Family category (MF) provides for medium to high density multi-family dwelling units such as apartments, dense detached rental units, and condominiums. The density in the MF category shall not exceed 30 dwelling units per gross acre. Buildings that exceed three stories or thirty five feet in height shall require special approval from the City Fire Marshal.

Plan of Development

Commercial – The Commercial category (C) is designed to meet the demand for commercial development along State Highway 288 and/or major thoroughfares or County Roads.

Institutional – The Institutional category (I) is intended to provide for the development of public and private uses that serve the community. Institutional uses may include, but are not limited to, public and private schools, day care facilities, hospitals, churches or other places of worship, etc.

Mixed-Use – The Mixed-Use category (MU) is intended to provide flexibility on individual tracts through the design process. Permitted uses are multi-family, commercial, and institutional, and the regulations are as defined in the corresponding categories.

Land uses may be relocated within the boundaries of the Plan of Development, provided they are in compliance with the overall Plan of Development. The city will be notified of any changes to the Preliminary Land Use Plan. However, the total Parks and Open Space may not decrease more than ten (10) percent without approval of the Planning Commission and City Council. The Parks and Open Space Exhibit shall be the basis for establishing and calculating any changes to the parks and open space land use by future administrative approvals as described in the administrative section of this Plan of Development.

The table below illustrates the primary Residential Land Use categories with their respective range of typical lot widths (measured at the building setback line) and the proposed product mix for the overall development. An estimated projected lot count by category is included within the table along with an allowable deviation percentage that would not require a resubmittal or amendment to the Plan of Development to City Council. Additionally, the overall density within the Plan of Development shall not exceed 3.16 units per gross acre and would allow for a potential maximum of 3,000 allowed single-family and multi-family units. Under no circumstances may the number of Type I and Type II lots combined exceed 1,800 units.

Specialty Product is not currently allotted within the table below, but the Developer reserves the right to reallocate the proposed Product/Lot mix from other residential land use categories should there be Market/Builder interest in any given Specialty Product type. Any reallocation would be in compliance with the allowed deviation percentages shown below or would require an amendment to the Plan of Development.

Residential Land Use Type	Lot Width (Typical)	Proposed Lot Mix (by Lot Counts)	Allowed Deviation
Type I	60.0' +	41%	+/- 5%
Type II	50.0' – 59.9'	38%	+/- 10%
Type III	40.0' – 49.9'	21%	+/- 10%

Plan of Development

D. Benefits to the City of Iowa Colony

The Plan of Development will help meet the demand for quality residential and commercial development as the City of Iowa Colony continues to grow and will enable the City to achieve its vision for the future.

Master planned communities provide tremendous benefits for cities over traditional “piecemeal” development. Property values in master planned communities tend to be greater and more stable than property values outside of master planned communities, providing cities with a greater ability to plan and fund services. Additionally, residents of master planned communities typically call upon public services, including public safety, at a lower rate than in other areas that are not master planned, deed restricted, and managed by strong homeowner’s associations. Most importantly, master planned communities bring stability and predictability that facilitate a city’s long-range planning and financial objectives.

The incorporation of institutional uses and community recreation centers within the Project will enhance the quality of life in Iowa Colony by promoting community activities and involvement. The rural character of the area will be preserved by creating an extensive system of greenways and drainage corridors providing an extensive open space and trail network. By creating an environment that encourages people to form bonds and share experiences, the Project will establish a cohesive community of people that blends with and preserves Iowa Colony’s values.

In addition, the Project will help create the “rooftops” necessary to drive the commercial development planned in Iowa Colony, which will generate sales tax and personal property tax revenue for the City.

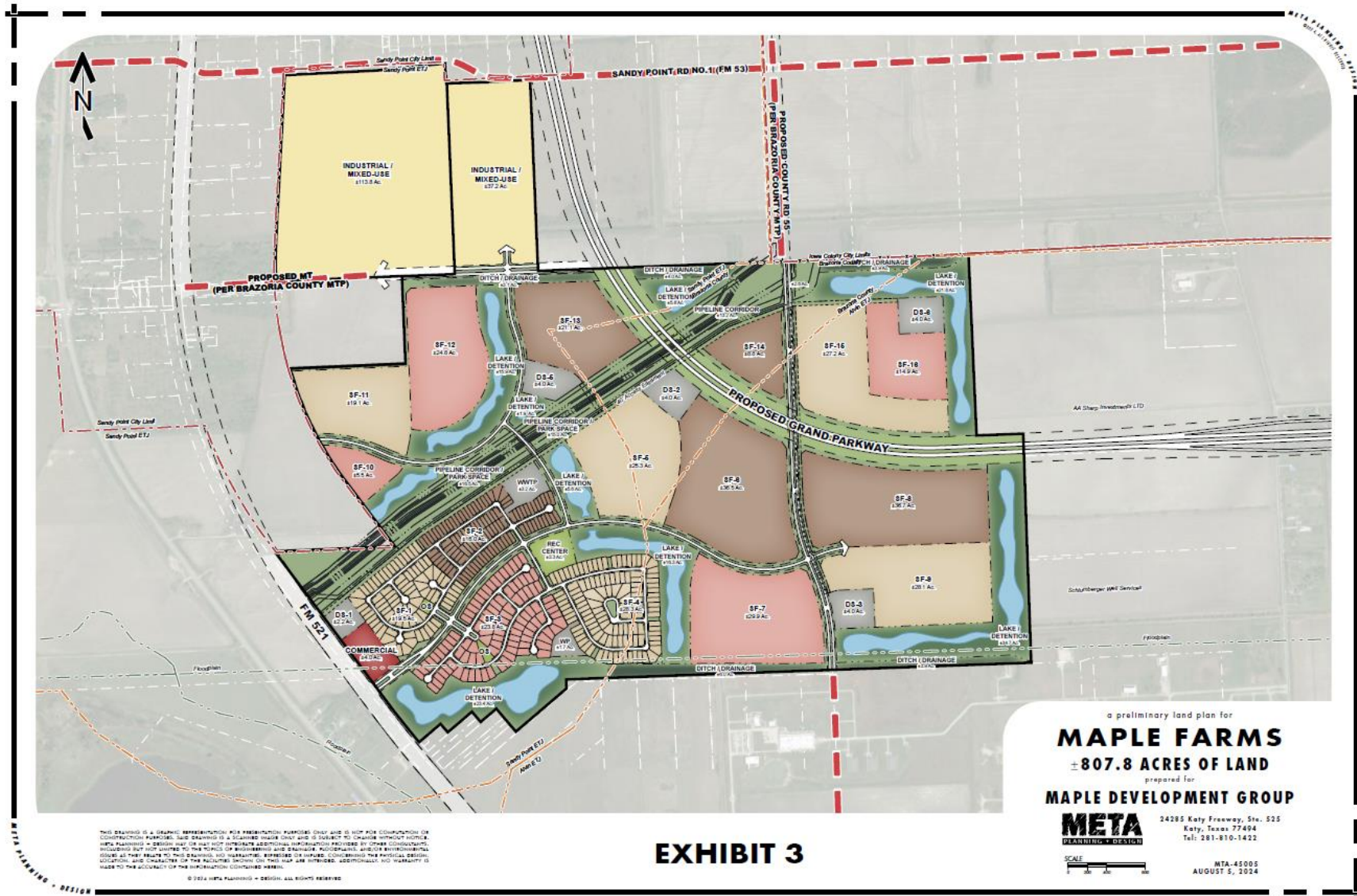

Plan of Development

E. Transportation

The Project will establish a transportation network consisting of streets and other forms of transportation designed to meet the mobility needs of the community and to compliment the development of Iowa Colony.

1. Existing Access

The Project lies along FM 521 as its western boundary and has access from CR 53 aka Sandy Point Road 1 for part of its northern boundary. Future TX-99 (Grand Parkway) will bisect the tract from north to east with a large curve. Future Creekhaven Parkway and Ames Road will cross the tract in east-west and north-south directions respectively.

2. Street Hierarchy

The street system in the 949 Ac SH 288 Tract will consist of a hierarchy of streets ranging from major thoroughfares to alleys. The intent of the system is to establish a series of streets that are sized appropriately for the land uses that they serve and to direct traffic within the community to the collector streets and major thoroughfares while discouraging any negative impact on residential neighborhoods and surrounding properties. The following is a brief description of street types that may be implemented within the 949 Ac SH 288 Tract:

Major/Minor Arterials – Major Arterials are intended to serve as principal thoroughfares identified as Major Arterial Streets on the City’s Thoroughfare Plan.

Major/Minor Collector Streets – Collector Streets are intended to help distribute traffic between major thoroughfares and other collector streets and are identified as Collector Streets on the City’s Thoroughfare Plan.

Local Streets – Local Streets are designed to provide access to residential lots and shall have a 10’ public utility easement on both sides of the right-of-way when the right-of-way is 50-feet in width.

Private Streets (Type 1) – Type 1 Private Streets will be privately maintained and may be gated. The right-of-way for Type 1 Private Streets shall be identified as a 50-foot-wide permanent access easement (PAE) and public utility easement (PUE) in order to allow for public utility service. Any gates shall be equipped to provide for police, fire, and emergency access.

Private Streets (Type 2) – Type 2 Private Streets may be used in lieu of local streets to provide access to more dense types of housing such as patio homes, townhomes, or condominiums. Type 2 Private Streets will be privately maintained and may be gated. Any gates shall be equipped to provide for police, fire, and emergency access. Underground utilities

may be designed and constructed under the pavement section but must be privately maintained.

Alleys – Alleys may be commercial or residential and are intended to provide vehicular access to the side or rear of buildings or properties that front on a local street, or type 1 or type 2 private street.

3. Minimum Right-of-Way Widths & Paving Sections

Streets within the Project shall conform to the EDCM except as identified in the following standards:

TABLE 1		
Minimum Right-of-Way Width & Paving Sections		
	Minimum Right-of- Way Width	Standard Paving Section (Measured from back of curb to back of curb)
Local Street	50 feet	28 feet
Private Street (Type 1)	50 feet	28 feet
Private Street (Type 2)	28 feet	28 feet
Private Alley	20 feet	14 feet ¹

- 1) Paving for alleys shall be measured from pavement edge to pavement edge, as curbs are not provided.
- 2) Where the local street right-of-way is fifty feet (50') in width there shall be a 10' public utility easement on both sides of the right-of-way.

4. Street Design Criteria

Streets within the project shall conform to the EDCM except as identified in the following standards:

Cul-de-sacs: Cul-de-sac streets within residential areas shall be measured along the centerline of the street from the nearest intersecting street to the center of the terminus bulb. The maximum length of cul-de-sacs in residential areas shall be determined by the number of vehicle trips generated per day, which shall not exceed 350. For the purposes of this requirement, the following standard shall apply:

Detached Units – 10 vehicle trips per day per unit (35 units)

Attached units – 8 vehicle trips per day per unit (44 units)

In no case shall cul-de-sacs exceed 800 feet in length.

Landscape “islands” having a maximum radius of sixteen (16) feet shall be permitted within cul-de-sac bulbs.

Cul-de-sacs in non-residential areas shall be considered on a case-by-case basis by the City's Designated Official.

Intersections: Streets and alleys shall be designed to intersect as nearly as possible to right angles.

No street or alley shall intersect any other street at less than 70 degrees.

Right-of-way lines at intersections of major thoroughfares and collector streets shall transition with a minimum 30-foot or 35-foot radius curve. Right-of-way lines at intersections of neighborhood collector streets, local streets, type 1 private streets, and type 2 private streets shall transition with a minimum 25-foot radius curve.

Where alleys (either public or private) intersect with local streets, type 1 private streets, or type 2 private streets, property lines shall transition with a minimum 15-foot radius curve and shall have a minimum 15-foot radius paving transition.

Curves: Curves along major thoroughfares shall be designed to meet or exceed minimum AASHTO standards. International Transportation Engineers (ITE) Context Sensitive Solutions shall be allowed.

Curves along collector streets shall have a minimum centerline radius of 300 feet. Reverse curves shall be separated by a tangent distance of not less than 100 feet.

Curves along local streets shall have a minimum centerline radius of 100 feet. Reverse curves shall be separated by a tangent distance of not less than 50 feet. This standard shall not apply to "L type" intersections (corner turns). These types of intersections shall have a minimum centerline radius of 50 feet.

Block Length: Major thoroughfares shall have a maximum block length of 2,600 feet with the following exception:

Major thoroughfares that run parallel to drainage features having a minimum width of fifty (50) feet shall have a maximum block length of 4,000 feet.

Collectors shall have a maximum block length of 1,800 feet and local streets shall have a maximum block length of 1,200 feet with the following exceptions:

Crossings of bayous or canals shall only be required by streets that are identified as major corridors on the City's Thoroughfare Plan and within the boundaries of the development.

The maximum block length along pipeline easements or drainage features having a minimum width of 50 feet shall be 2,000 feet.

The maximum block length along pipeline easements or drainage features having a minimum width of 225 feet shall be 4,000 feet.

Block length shall be measured between intersections from edge of right-of-way to edge of right-of-way.

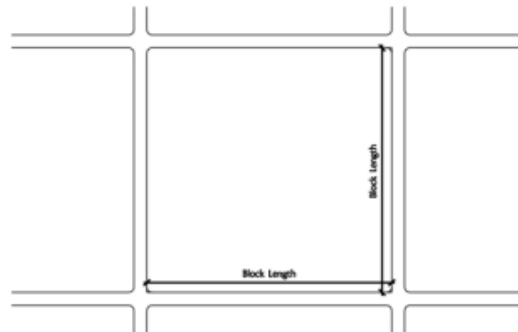

Traditional Block Length Measurement



Curvilinear Block Length Measurement

In cases where multiple blocks may exceed 1,200 feet, a pedestrian crossing will be provided having a minimum width of twenty (20) feet, as such a connection would significantly improve overall pedestrian circulation within the development.

Points of Access: All subdivision sections containing more than thirty-five (35) lots shall have a minimum of two points of access. A divided or boulevard entry consisting of two (2) minimum 20-foot-wide travel lanes separated by a median having a minimum width of 14 feet shall be acceptable in all circumstances and shall be considered two points of access for these purposes, provided that the divided paving section extends to the first intersecting street that is not a cul-de-sac and continues to provide two points of access to all other parts of the subdivision except cul-de-sac streets. Parking along the divided entry shall be prohibited. A divided or boulevard entry with a loop shall be considered two points of access. If the loop is not completed and there

are over thirty-five (35) lots, a temporary emergency access easement shall be provided until such point that the loop has been completed.

All subdivision sections, regardless of the number of lots, will require a minimum of two points for emergency protection access. One of the points may be a gated driveway with a 911 emergency gate/KNOX lock box system for emergency protection personnel use only.

Lot Frontage: Each single-family residential unit as defined above shall have frontage on a local street, type 1 private street, type 2 private street or common area.

Lots that front on a common landscaped area must have vehicular access provided by a local street, type 1 private street, type 2 private street, or an alley from the side or rear. In addition, the common landscaped area must have a minimum dimension of twenty (20) feet.

Lots may not have direct vehicular access to a major thoroughfare or collector street unless the lot is one acre or greater in size and provides a turnaround that prohibits vehicles from backing onto the major thoroughfare or collector.

Dead-End Streets: Type 2 private streets may extend up to 200 feet without a turnaround. Dead-end Type 2 private streets that exceed 200 feet in length shall provide a turnaround in accordance with the diagram shown below. Dead-end streets other than Type 2 Private Streets shall be terminated with a cul-de-sac.

Dead-End Alleys: Residential alleys may extend up to 200 feet without a turnaround. Dead-end residential alleys that exceed 200 feet in length shall provide a turnaround in accordance with the diagram shown below. Non-residential alleys may not dead-end.

TYPE 2 PRIVATE STREET & ALLEY TURNAROUND OPTIONS

Plan of Development

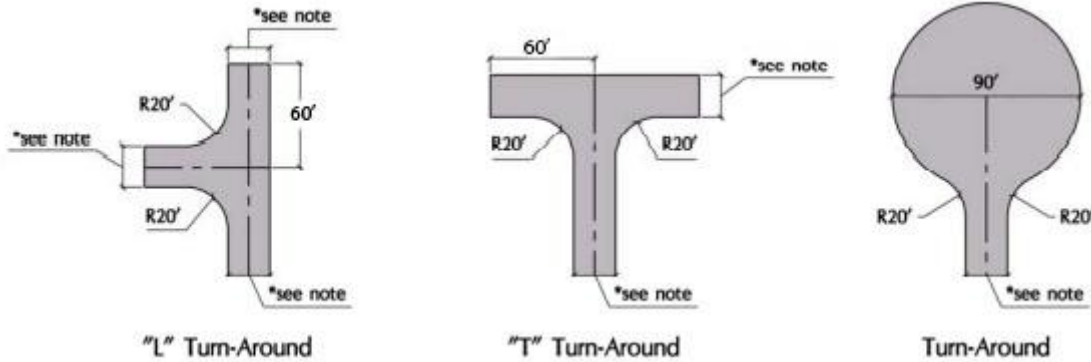

*Note: Dimension shall match the corresponding paving width.

Any deviation from this section shall be considered on a case-by-case basis and shall require written approval from the City's Designated Official.

5. Street Sidewalks

Sidewalks shall be provided in accordance with the following schedule:

TABLE 2			
Sidewalk Requirements			
Street Type	Minimum Requirement		
Major Arterial	6-foot sidewalks shall be provided on both sides of the street	OR	An 8-foot sidewalk shall be provided on one side of the street
Major Collector	6-foot sidewalks shall be provided on both sides of the street	OR	An 8-foot sidewalk shall be provided on one side of the street
Minor Collector	5-foot sidewalks shall be provided on both sides of the street	OR	A 6-foot sidewalk shall be provided on one side of the street
Local Street	5-foot sidewalks shall be provided on both sides of the street		
Private Street (Type 1)	5-foot sidewalks shall be provided on both sides of the street		
Private Street (Type 2)	5-foot sidewalks shall be provided on both sides of the street		

* 6-foot sidewalks shall be provided at bridge crossings.

Generally, sidewalks should be constructed within the right-of-way. However, sidewalks along Type 2 Private Streets shall be constructed on private property within a sidewalk easement located within 10 feet of the edge of paving. Sidewalks adjacent to open space areas and pipeline corridors may meander between the right-of-way and open space when desired. When separate trails exist or are proposed on an adjacent reserve of open space area, parallel sidewalks shall not be required provided that the trail is

Plan of Development

constructed of concrete. If a sidewalk is provided on only one side of the street and it meanders outside the right-of-way, it must return to the right-of-way at least every 1,400 feet.

Deviations from the above schedule will be considered on a case-by-case basis, subject to approval by City's Designated Official.

6. Traffic Signalization

A Traffic Impact Analysis will be required to determine if traffic signals are warranted. If it is determined that a signalized intersection is warranted per the Engineering Design Criteria Manual, the Developer shall fully fund the traffic signal at the affected intersection(s). If a traffic signal is not warranted, the Developer shall have no obligation to fund design or construction for that intersection.

F. Parks, Open Space & Trails

1. Parks & Open Space

Parks and Open Space are the central feature of the City's vision for Iowa Colony and the community. The Project will provide connectivity within and among the internal subdivisions as well as to other developments in Iowa Colony. Within the Project, several mitigation areas and man-made detention basins will be created that will extend into the community through trail connections and/or pedestrian/bicycle paths. These detention basins will be contoured and landscaped to a standard commensurate with typical developments in the greater Houston area, forming the backbone of the open space system and providing a common greenway core that binds the community together.

In addition to the greenway network, many active recreational facilities will be developed and built within the Project, ranging from small pocket parks to the larger neighborhood parks which will be connected through an extensive pedestrian trail system. This will provide ample areas for recreational activities. The Parks, Open Space, & Trails Plan illustrates the proposed parks and open space areas within the Project.

The City of Iowa Colony Zoning and Ordinance for planned unit development regulations require that 1 acre per 54 dwelling units be dedicated to parkland and compensating open space (COS). Based on a total unit count of 2,500 units, the projected requirement for the Project is 46.0 acres.

Approximately 258.0 acres of land within the Project is planned to be designated as parks and open space, as shown in the proposed Parks Plan and will include passive parks, neighborhood parks, recreational centers, tot lots, pipeline easements corridors, drill sites, lakes, creeks, drainage channels, detention basins, and landscape and open space networks. The parks requirement will be fulfilled with the implementation of the Parks Plan. All land which is dedicated for the purpose of fulfilling the parkland/

Plan of Development

compensating open space requirements will be credited at 100%, except for drainage/detention, creeks, and detention areas, which will be credited at 50%.

The drainage and detention system within the Plan of Development will be amenitized by providing open space and trail connectivity between the different land uses and neighboring developments. The drainage and detention areas will not only enhance the aesthetic quality of the environment, they will provide connectivity through the development and provide numerous opportunities for enjoyment by the residents.

The recreation and open space areas will also provide separation, buffer zones, and transitions between areas and types of development.

Parks will be owned and maintained by the City, District, or Home Owner's Association. Other than a few private areas, such as Recreation Centers and pools, all parks and open space areas will allow general public use. The trail system around and through the community will be accessible to the public along with any improvements to detention areas or other open space. Open space areas shall include pipeline and utility easements, drainage ways, and wet and dry detention areas.

The Parks, Open Space, & Trails Plan is preliminary in nature. The specific location of individual parks or open spaces may be moved or combined as the design and development of the Project moves forward. The parkland and compensating open space requirements will not be required within individual sections/neighborhoods as long as each section is in accordance with the Parks and Open Space plan and when considered for the overall project as a whole.

2. Trails

In addition to the required street sidewalks, the Project will feature an extensive trail system that will extend throughout the community providing access to the various destination centers, including commercial areas, recreation centers, schools, and parks. This system may be comprised of both paved and unpaved trails and will be linked to the required sidewalks throughout the community. The trail system within the Project will be maintained by the City, District, or Home Owner's Association.

The Parks, Open Space, & Trails Plan identifies the proposed location of trails within the Project. Trails may be paved or unpaved and constructed of materials that are appropriate for the specific application. The Parks, Open Space, & Trails Plan is preliminary in nature. The specific location of individual trails may be moved or combined as the design and development of the Project moves forward.

3. Tree Preservation

The subject property is largely agricultural fields, with only a few areas being partially wooded. Of these wooded areas, the majority of the vegetation appears to be new growth trees and brush, with none appearing to be significantly sized shade trees or

Plan of Development

being of any cultural significance that would cause any existing trees on the property to be designated as protected trees under the City's tree preservation guidelines.

As part of the development's landscape design, the developer will implement an overall landscape plan to promote increased biodiversity, habitat creation, and naturalistic planting areas throughout the development for the added benefit and use of future residents and fauna. These plantings along with the Parks, Open Space, and Trails Plan will create strong pedestrian connections throughout the development and promote the creation of greenways and other trail systems similar to the idea of the Green Corridors as described in the City's UDC.



THIS DRAWING IS A GRAPHIC REPRESENTATION FOR PRESENTATION PURPOSES ONLY AND IS NOT FOR CONSTRUCTION OR CONSTRUCTION PERMITS. THIS DRAWING IS A SCHEMATIC DRAWING AND IS SUBJECT TO CHANGE WITHOUT NOTICE. META PLANNING & DESIGN HAS OR MAY NOT OBTAIN ADDITIONAL INFORMATION PROVIDED BY OTHER CONSULTANTS, INCLUDING BUT NOT LIMITED TO THE RECORDS OF SURVEYORS AND ENGINEERS, ARCHITECTS, AND/OR ENVIRONMENTAL ENGINEERS AS THEY RELATE TO THIS DRAWING, AND WARRANTS, EXPRESS OR IMPLIED, CONCERNING THE PHYSICAL DESIGN, ACCURACY AND CHARACTER OF THE FACILITIES SHOWN ON THIS PLAN ARE LIMITED. RESPONSIBILITY AND WARRANTY IS MADE TO THE ACCURACY OF THE INFORMATION CONTAINED HEREIN.

© 2024 META PLANNING & DESIGN. ALL RIGHTS RESERVED.

EXHIBIT 4

a parks, open space, & trails plan for
MAPLE FARMS
 ± 807.8 ACRES OF LAND
 prepared for
MAPLE DEVELOPMENT GROUP



24285 Katy Freeway, Ste. 515
 Katy, Texas 77494
 Tel: 281-910-1422



MTA-45005
 AUGUST 5, 2024

Plan of Development

G. Infrastructure

1. Municipal Utility Districts

The Project will be served by one or more municipal utility districts. These districts will be responsible for the design and construction costs of certain public water, storm, drainage, and recreation facilities for the project. The City of Iowa Colony will assume the maintenance and operation of the public water and sanitary sewer, storm drainage lines, and streets. The municipal utility district(s) and/or the homeowners association(s) created to serve the property within the Project own and operate all parks and open space facilities within the Project.

2. Water

Water service will be provided by one or more groundwater plants within the community. Water will be distributed by a central water distribution plan designed in accordance with the City of Iowa Colony's Engineering Design Criteria Manual.

3. Wastewater

Wastewater service will be provided by a temporary wastewater plant within the community until such time that the municipal utility district constructs (or funds the construction of) a permanent wastewater treatment plant as required by the Utility Functions Agreement entered into by and between the City of Iowa Colony and the Developers. The sewer collection system will be designed in accordance with the City of Iowa Colony's Engineering Design Criteria Manual and Brazoria County Drainage District Number 5.

4. Storm Drainage & Detention System

The storm drainage system will consist of a network of closed conduit storm sewers draining to surface swales, conveyance channels, and detention ponds. The detention ponds will outfall to an existing Brazoria County Drainage District No. 5 ditch. The drainage system will be designed in accordance with the City of Iowa Colony's Engineering Design Criteria Manual.

5. Flood Plain Management

A portion of the tract lies within a defined floodplain by the FEMA FIRM maps. Any development proposed in the floodplain will meet FEMA and the Floodplain Administrator's design criteria for development within the floodplain.

6. Other Utilities

Electrical service for the community will be provided by CenterPoint. Gas service will be provided in the community. High speed internet service will be provided in the community.

7. Schools

Plan of Development

The Project is located partially within the Alvin Independent School District and partially within the Angleton Independent School District.

8. Homeowner's Association & Architectural Review Committee

A Master Homeowner's Association (HOA) will be created to promote community involvement, maintain common areas, and to enforce deed restrictions and covenants. Copies of these restrictions and covenants will be provided to the City. The City of Iowa Colony will in no way be responsible for the enforcement of these private covenants.

In addition to the HOA, an Architectural Review Committee (ARC) will be established to ensure conformance to the development standards contained within the Plan of Development and enforce any additional design guidelines which shall be established separately.

There may be additional sub-homeowner associations, and Property Owner's Associations (POA) may be established for non-residential property owners for the same purposes as Homeowner's Associations.

H. Project Phasing

The phasing strategy for the Project provides a balanced approach relative to anticipated market demands. The Project Phasing Plan illustrates the proposed phasing plan for the Project. This plan is subject to change based on market demands, availability of infrastructure, physical encumbrances, or legal limitations. The City will be notified of any changes to the Project Phasing plan but will not require a resubmittal of the initial proposed Phasing Plan in the exhibit below.

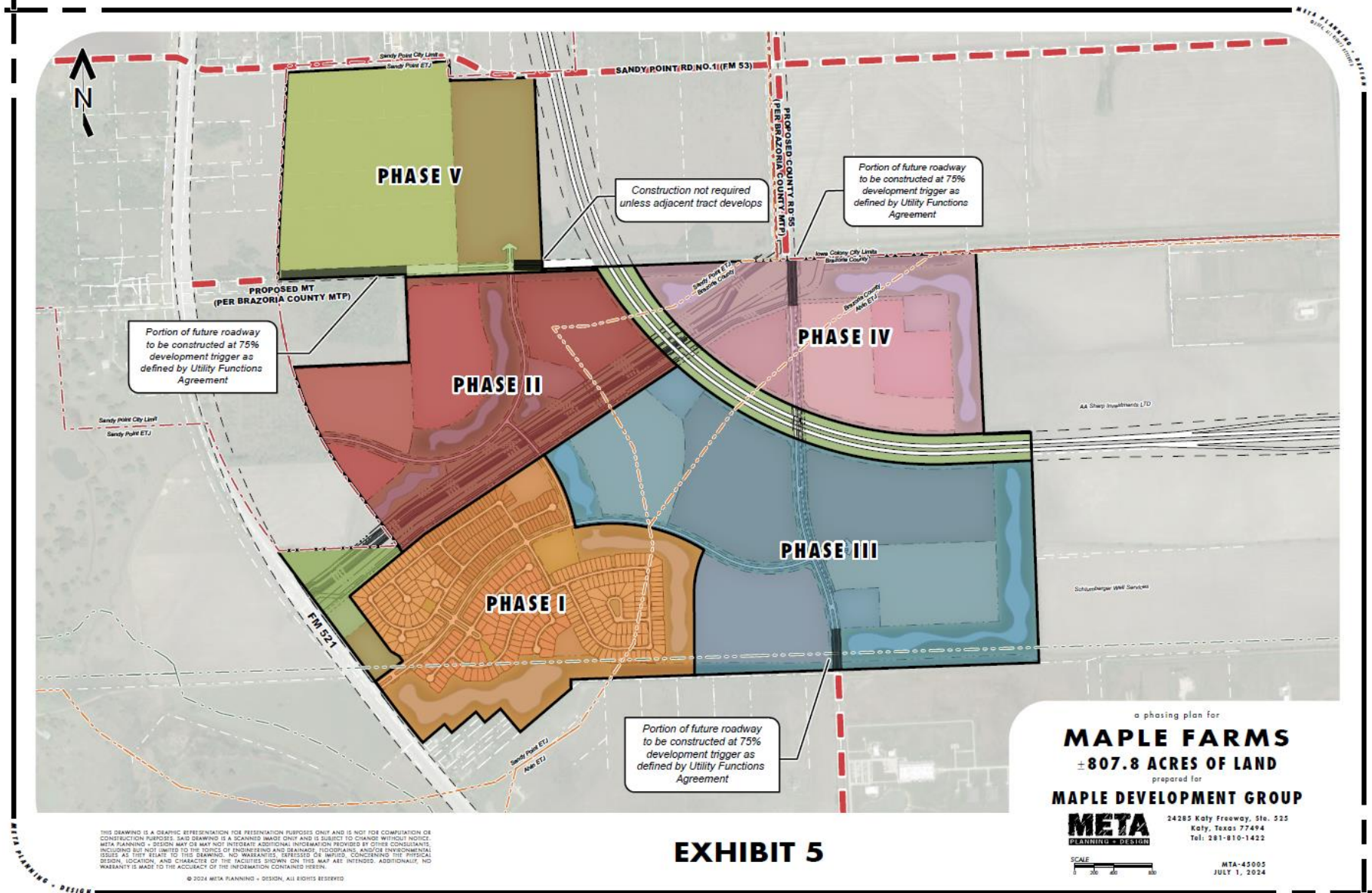

THIS DRAWING IS A GRAPHIC REPRESENTATION FOR PRESENTATION PURPOSES ONLY AND IS NOT FOR COMPUTATION OR CONSTRUCTION PURPOSES. SAID DRAWING IS A SCANNED IMAGE ONLY AND IS SUBJECT TO CHANGE WITHOUT NOTICE. META PLANNING + DESIGN MAY OR MAY NOT INCORPORATE ADDITIONAL INFORMATION PROVIDED BY OTHER CONSULTANTS, INCLUDING BUT NOT LIMITED TO THE TOPICS OF ENGINEERING AND DRAWINGS, RECORDS, AND/OR ENVIRONMENTAL ISSUES AS THEY RELATE TO THIS DRAWING. NO WARRANTIES (EXPRESSED OR IMPLIED, CONCERNING THE PHYSICAL DESIGN, LOCATION, AND CHARACTER OF THE FACILITIES SHOWN ON THE MAP ARE INTENDED. ADDITIONALLY, NO WARRANTY IS MADE TO THE ACCURACY OF THE INFORMATION CONTAINED HEREIN.

© 2024 META PLANNING + DESIGN. ALL RIGHTS RESERVED

EXHIBIT 5

a phasing plan for

MAPLE FARMS

± 807.8 ACRES OF LAND

prepared for

MAPLE DEVELOPMENT GROUP

META
PLANNING + DESIGN

24285 Katy Freeway, Ste. 525
Katy, Texas 77494
Tel: 281-810-1422

SCALE
0 200 400 600

META-45005
JULY 1, 2024

Plan of Development

III. DEVELOPMENT REGULATIONS

A. Purpose & Intent

The purpose of the development regulations is to serve as the primary means of achieving the goals and objectives of the Development Plan.

They are designed to establish clear minimum development standards while providing a reasonable amount of flexibility in order to accommodate future needs.

B. General Provisions

1. Applicability

The regulations contained herein shall apply to all property located within the boundaries of the Plan of Development. Appendix 1 contains the legal description of the Property. All construction and development within the Plan of Development area shall comply with applicable provisions of the City of Iowa Colony codes and ordinances as they exist on the date of adoption of this Plan of Development and the laws of the State of Texas, except as modified within this document or within any mutually agreed amendments to this Plan of Development. Any future amendments by the City to their UDC, Zoning Ordinance, PUD Ordinance or any other applicable ordinance governing the development of property will not be applicable to this development with the exception of updates to the Engineering Design Criteria Manual or any applicable codes related to public safety. Where conflicts or differences exist between this Plan of Development and other City Ordinances, the Plan of Development shall be the governing document.

If specific development standards are not established or if an issue, condition, or situation arises or occurs that is not clearly addressed or understandable in the Plan of Development, then those regulations and standards of the City of Iowa Colony codes and ordinances that are applicable for the most similar issue, condition, or situation shall apply as determined by the City's Designated Official. Appeal of any determination regarding applicability may be made to City Council.

This Plan of Development may be amended by the same procedure as it was adopted, by ordinance. Each amendment shall include all sections or portions of the Plan of Development that are affected by the change.

2. Additional Uses

In the event that a proposed use has not specifically been listed as a permitted use in a particular land use category within the Plan of Development, it shall be the duty of the City's Designated Official to determine if said use is: 1) consistent with the intent of the land use category; and 2) compatible with other listed permitted uses.

3. Non-Conforming Land Uses

Plan of Development

Where, at the adoption of this Plan of Development, a lawful use of land exists which would not be permitted by the regulations imposed by this Plan of Development, such use may continue so long as it remains otherwise lawful, provided:

- No non-conforming use shall be enlarged, increased, or extended to occupy a greater area of land than was originally occupied at the date of adoption of this Plan of Development.
- No non-conforming use shall be moved, in whole or in part, to any lot or parcel within the Plan of Development.
- If any non-conforming use ceases for a period of more than 180 days, any subsequent use of the land shall conform to the regulations established by this Plan of Development.
- No additional structures shall be erected in connection with any non-conforming use that does not conform to the regulations established by this Plan of Development.

4. Non-Conforming Structures

Where, at the adoption of this Plan of Development, a lawful structure exists which would not be permitted by the regulations imposed by this Plan of Development, such structure may continue to exist so long as it remains otherwise lawful, provided:

- No non-conforming structure shall be enlarged, increased or extended beyond its size at the date of adoption of this Plan of Development.
- In the event that any non-conforming structure or non-conforming portion of a structure is destroyed by any means to an extent of more than 50 percent of its replacement cost at the time of destruction, it shall not be reconstructed except in conformity with the regulations established by this Plan of Development.
- No non-conforming structure shall be moved, in whole or in part, to any lot or parcel within the Plan of Development.

5. Existing Utilities

Existing utilities and all uses allowed by existing easements shall continue to be permitted in all designations within the Plan of Development.

6. Drill Sites

The proposed drill sites (the Drill Sites) are within the Project as currently planned and designed to provide access to the mineral estate as the Project develops. The Drill Sites are essential to the orderly and efficient development of the Project, now and in the future. The Drill Sites will be administratively created through an established process with the Railroad Commission of Texas (the Commission) in coordination with specialist attorneys/consultants and representatives of the mineral owners who elect to participate in the process. The size, location, and necessary additional easements to

Plan of Development

access the Drill Sites have been designed in keeping with the best practices used throughout the oil and gas industry for this purpose. Upon issuance of a final order by the Commission establishing Drill Sites and related easements for the Property pursuant to Chapter 92 of the Texas Natural Resources Code, entitled “Mineral Use of Subdivided Land” and Commission Statewide Rule 76 (the Final Order), the City will acknowledge and accept all of the Drill Sites and related pipeline and access easements as described in the Commission’s Final Order as supplanting, in all respects regarding the Property, the application of City of Iowa Colony Ordinance No. 88-1.

Any future surface operations conducted by a mineral interest owner, its lessee, or assign on the Property will be limited to the areas of these designated Drill Sites. Oil and gas exploration and production operations on the Drill Sites shall be permitted provided that such operations comply with the Commission’s Final Order and all other applicable Commission regulations in effect at the time the individual permits are approved by the City. In the event of a conflict between the terms of the Commission’s Final Order and City Ordinance 88-1, the terms of the Final Order shall control.

Until such time as these Drill Sites are used for oil and gas operations, the developers may utilize the Drill Sites as public open spaces for recreational/park space and may construct non-permanent facilities on such Drill Sites, including trails, sidewalks, parking areas, or other similar non-permanent facilities, at the discretion of the developers.

7. General Development Plan

A general development plan illustrating all contiguous property under one ownership or under common control or legal interest shall be submitted for approval of the Planning Commission prior to or simultaneously with the application for the first preliminary subdivision plat. The General Development Plan shall show the following:

- The alignment of any major thoroughfares and collector streets in accordance with the City’s Thoroughfare Plan.
- All recorded easements
- Other proposed streets that are necessary to demonstrate an overall circulation system for the development
- Proposed land uses and public facilities

The General Development Plan shall eliminate the requirement of a master preliminary plat set forth in the City of Iowa Colony Subdivision Ordinance. At a minimum, a new general development plan will be submitted to the City for review with each phase. Preliminary plats shall be required for each section of development with the exception of minor plats as defined by state law.

Preliminary plats should generally conform to the General Development Plan. Any significant change, as determined by the City’s Designated Official, shall require the

Plan of Development

submittal of a revised general development plan for approval by the Planning Commission.

8. Mass Grading & Construction of Detention

The developer shall be permitted to commence clearing and grubbing without platting but must have approved plans and permits. Detention and mass grading will be commenced upon approval of drainage study, construction plans, and permits. For road construction, grading may commence upon the approval of construction drawings and permits. Preliminary plat approval will be required to commence roadway construction. However, prior to any grading activity a Storm Water Pollution Plan must be submitted, and any required City of Iowa Colony grading permits must be obtained. The City may issue the necessary permits prior to the approval of construction plans and plat recordation with the understanding that any grading performed under these circumstances shall be at the risk of the developer.

9. Temporary Uses

Temporary uses conducted in connection with the development of the property shall not require zoning permits from the city, but will require health and safety permits (electrical, plumbing, structural, HVAC, etc.). All temporary uses must be approved by the developer or the Architectural Review Committee. These uses may include, but are not limited to:

- Sales office
- Construction office
- Construction/storage yards
- Construction roads
- Fencing
- Water pumps and ponds
- Concrete batch plants or rock crushing operations and equipment for the processing of on-site materials provided such operations:
 - a.) Maintain a 1,000-foot separation between all operations or storage and the nearest occupied residence;
 - b.) Limit hours of operation to between 7:00 a.m. and dusk, Monday through Friday;
 - c.) Do not include the import or export of materials except as to be used on the property or for off-site improvements related to the project; and
 - d.) Are enclosed by a solid/opaque fence having a minimum height of six (6) feet.

Plan of Development

Notwithstanding the foregoing, manufactured or mobile homes may be placed on the Property for the following uses only: (1) for use by residents who intend to vote in a confirmation election (which may include other ballot initiatives), or (2) for use as a construction office or trailer in connection with the construction of improvements to serve the Property.

10. Design Guidelines

Design guidelines will be created which will address site and building design within the Project. The purpose of these guidelines will be to preserve the character of Project by establishing high quality design standards for development. Copies of these guidelines will be provided to the City prior to the preliminary plat submittal of any single-family residential sections.

11. Lighting

All lighting within the Project will be subject to standards established in the project design guidelines. These standards will help to ensure that attractive, high-quality lighting is provided throughout the community.

12. Screening and Fencing

All screening and fencing within the Project will be subject to standards established in the project design guidelines. The screening and fencing standards will help to establish and maintain tasteful screening and fencing throughout the community that will withstand the pressures of time and nature.

13. Architectural Standards

The architectural standards within the Project will be subject to standards established in the project design guidelines. The architectural standards will help to assure that buildings within the community are of a high quality and are aesthetically appealing.

C. Development Standards

1. Traditional Single Family Residential (TSFR)- Type I

Purpose: The Traditional Single-Family Residential category is intended for the development of detached, single family dwelling units and compatible uses. This district is designed to allow a variety of housing choices in order to create a viable community while allowing for a reasonable amount of flexibility to accommodate ever-changing market demands.

Permitted uses:

- Accessory structures
- Community centers
- Drill sites
- Entry features & monuments

Plan of Development

- Institutional uses
- Minor utilities
- Open space
- Parks
- Recreational facilities
- Religious assembly
- Single family homes
- Temporary uses
- Home Occupations

Minimum Lot Area: 6,600 square feet
Minimum Lot width: 60 feet at the building setback line

Minimum Setbacks:

- Front: 20 feet
20 feet on cul-de-sacs and knuckles regardless of lot width
5 feet for lots that front on a common area
- Rear: 10 feet**
- Side: 5 feet**
- Corner: 10 feet*

*Porches (if provided) may encroach into the front setback up to five (5) feet provided they have a minimum depth of six (6) feet. On corner lots, porches may encroach into the side setback up to five (5) feet provided they have a minimum depth of six (6) feet. Where garages face directly onto a street with the garage door parallel to the street, the garage must meet the minimum setback requirement. Side-entry garages where the garage door is perpendicular to the street may be set back a minimum of ten (10) feet.

**One Story accessory structures may be set back three (3) feet from the rear or side property lines provided that they do not encroach into any utility easement. Accessory structures greater than one story in height must comply with the minimum setback requirements.

Architectural features may encroach into the setback area a maximum of three (3) feet and may not extend more than five (5) feet above the principal structure.

Plan of Development

Maximum Building Height: Two (2) stories or 35-feet. Three (3) stories may be allowed with fire marshal approval.

Parking Requirement: Shall comply with the parking standards established in this section.

2. Traditional Single Family Residential (TSFR)- Type II

Purpose: The Traditional Single-Family Residential category is intended for the development of detached, single family dwelling units and compatible uses. This district is designed to allow a variety of housing choices in order to create a viable community while allowing for a reasonable amount of flexibility to accommodate ever-changing market demands.

- Permitted uses:
- Accessory structures
 - Community centers
 - Drill sites
 - Entry features & monuments
 - Institutional uses
 - Minor utilities
 - Open space
 - Parks
 - Recreational facilities
 - Religious assembly
 - Single family homes
 - Temporary uses
 - Home Occupations
- Minimum Lot Area: 6,000 square feet
- Minimum Lot width: 50 feet at the building setback line
- Minimum Setbacks:
- Front: 20 feet
 - 20 feet on cul-de-sacs and knuckles regardless of lot width
 - 5 feet for lots that front on a common area
 - Rear: 10 feet**

Plan of Development

Side: 5 feet**

Corner: 10 feet*

*Porches (if provided) may encroach into the front setback up to five (5) feet provided they have a minimum depth of six (6) feet. On corner lots, porches may encroach into the side setback up to five (5) feet provided they have a minimum depth of six (6) feet. Where garages face directly onto a street with the garage door parallel to the street, the garage must meet the minimum setback requirement. Side-entry garages where the garage door is perpendicular to the street may be set back a minimum of ten (10) feet.

**One Story accessory structures may be set back three (3) feet from the rear or side property lines provided that they do not encroach into any utility easement. Accessory structures greater than one story in height must comply with the minimum setback requirements.

Architectural features may encroach into the setback area a maximum of three (3) feet and may not extend more than five (5) feet above the principal structure.

Maximum Building Height: Two (2) stories or 35-feet. Three (3) stories may be allowed with fire marshal approval.

Parking Requirement: Shall comply with the parking standards established in this section.

3. Traditional Single Family Residential (TSFR)- Type III

Purpose: The Traditional Single-Family Residential category is intended for the development of detached, single family dwelling units and compatible uses. This district is designed to allow a variety of housing choices in order to create a viable community while allowing for a reasonable amount of flexibility to accommodate ever-changing market demands.

- Permitted uses:
- Accessory structures
 - Community centers
 - Drill sites
 - Entry features & monuments
 - Institutional uses
 - Minor utilities
 - Open space
 - Parks
 - Recreational facilities

Plan of Development

Religious assembly

Single family homes

Temporary uses

Home Occupations

Minimum Lot Area: 4,600 square feet

Minimum Lot width: 40 feet at the building setback line

Minimum Setbacks:

Front: 20 feet

20 feet on cul-de-sacs and knuckles regardless of lot width

5 feet for lots that front on a common area

Rear: 10 feet**

Side: 5 feet**

Corner: 10 feet*

*Porches (if provided) may encroach into the front setback up to five (5) feet provided they have a minimum depth of six (6) feet. On corner lots, porches may encroach into the side setback up to five (5) feet provided they have a minimum depth of six (6) feet. Where garages face directly onto a street with the garage door parallel to the street, the garage must meet the minimum setback requirement. Side-entry garages where the garage door is perpendicular to the street may be set back a minimum of ten (10) feet.

**One Story accessory structures may be set back three (3) feet from the rear or side property lines provided that they do not encroach into any utility easement. Accessory structures greater than one story in height must comply with the minimum setback requirements.

Architectural features may encroach into the setback area a maximum of three (3) feet and may not extend more than five (5) feet above the principal structure.

Maximum Building Height: Two (2) stories or 35-feet. Three (3) stories may be allowed with fire marshal approval.

Parking Requirement: Shall comply with the parking standards established in this section.

4. Patio Home (PH)

Plan of Development

Purpose: The Patio Home category is intended for the development of detached, single family dwelling units. Patio homes may have a zero (0) foot side setback on one of the interior lot lines or five (5) feet side setbacks on both sides at the discretion of the developer, but all homes shall be separated by a minimum of ten (10) feet.

Permitted uses: Accessory structures

Community centers

Entry features & monuments

Institutional uses

Minor utilities

Open space

Parks

Patio homes

Recreational facilities

Religious assembly

Single family homes

Temporary uses

Home Occupation

Minimum Lot Area: 4,400 square feet

Minimum Lot width: 40 feet at the building setback line

Minimum Setbacks:

Front: 20 feet*

5 feet for lots that front on a common area

Rear: 10 feet**

Side: Zero (0) feet on one side provided that there is a minimum of ten (10) feet between structures. A minimum of fifteen (15) feet is required between one (1) and three (3) story structures. Five (5) feet side setbacks are also acceptable provided that there is a minimum of ten (10) feet between structures.

Corner: 10 feet*

*Porches (if provided) may encroach into the front setback up to five (5) feet provided they have a minimum depth of six (6) feet. On corner lots, porches

Plan of Development

may encroach into the side setback up to five (5) feet provided they have a minimum depth of six (6) feet. Where garages face directly onto a street with the garage door parallel to the street, the garage must meet the minimum setback requirement. Side-entry garages where the garage door is perpendicular to the street may be set back a minimum of ten (10) feet. (See lot diagram)

**Accessory structures may be set back three (3) feet from the rear or side property lines provided that they do not encroach into any utility easement.

Architectural features may encroach into the setback area a maximum of three (3) feet and may not extend more than five (5) feet above the principal structure.

Maximum Building Height: Two (2) stories or 35-feet. Three (3) stories may be allowed with fire marshal approval.

Parking Requirement: Shall comply with the parking standards established in this section.

Additional Requirements: Single family homes shall comply with the standards established in the Traditional Single-Family Residential category.

5. Townhome (TH)

Purpose: The Townhome category is intended for the development of attached single family dwelling units that are platted on individual lots and are owned fee simple.

Permitted uses: Attached single family dwelling units

Institutional uses

Entry features & monuments

Minor utilities

Open space

Parks

Patio homes

Recreational facilities

Religious assembly

Single family homes

Temporary uses

Home occupation

Minimum Lot Area: 2,200 square feet

Plan of Development

Minimum Lot Width: 22 feet at the building setback line

Minimum Setbacks:

Front: 20 feet if front loaded

10 feet if rear loaded

5 feet for lots that front on a common area

Rear: 5 feet

20 feet for lots that front on a common area

Side: Zero (0) foot side setbacks for units that are attached provided that there is a minimum of ten (10) feet between buildings. A minimum of fifteen (15) feet is required between one (1) and three (3) story structures.

Corner: 10 feet

Architectural features may encroach into the setback area a maximum of three (3) feet and may not extend more than five (5) feet above the principal structure.

Maximum Building Height: Three (3) stories or thirty-five (35) feet.

Parking Requirement: Shall comply with the parking standards established in this section.

Front loaded townhomes shall provide 0.25 off-street guest parking spaces per dwelling unit. Guest spaces may not be on townhome lots or streets and should be located within 300 feet of units.

Additional Requirements: Buildings shall consist of a minimum of two (2) units with a maximum of eight (8) units.

Buildings shall be separated by a minimum of ten (10) feet.

Each dwelling unit shall be platted on an individual lot.

Single family and patio homes shall comply with the standards established in their respective categories.

6. Quads (Q)

Purpose: The Quads category (Q) provides for the development of single-family dwelling units. Quads may consist of four (4) lots taking garage access from a shared driveway. Each lot shall have street frontage, and Quads shall have a minimum lot area of 3,500 square feet and a minimum lot width of 120 feet for the four-pack. The rear lots will have frontage through flag staffs which will have the shared driveway overlaid.

Permitted uses: Detached single family dwelling units

Plan of Development

- Institutional uses
- Entry features & monuments
- Minor utilities
- Open space
- Parks
- Recreational facilities
- Religious assembly
- Single family homes
- Temporary uses
- Home occupation

Minimum Lot Area: 3,500 square feet

Minimum Lot Width: 120 feet at the building setback line for the four-pack

Minimum Setbacks:

- Front: 20 feet if front loaded
10 feet if access is from a shared drive
- Rear: 5 feet
- Side: 5 feet
- Corner: 10 feet

Architectural features may encroach into the setback area a maximum of three (3) feet and may not extend more than five (5) feet above the principal structure.

Maximum Building Height: Two (2) stories or 35-feet. Three (3) stories may be allowed with fire marshal approval.

Parking Requirement: Shall comply with the parking standards established in this section.

Buildings shall be separated by a minimum of ten (10) feet.

Each dwelling unit shall be platted on an individual lot.

Single family and patio homes shall comply with the standards established in their respective categories.

7. Alley Product (AP)

Plan of Development

Purpose-The Alley Products category (AP) provides for the development of single-family dwellings. The Alley Products may have street frontage and alley frontage with primary garage access coming from the alley. Each Alley Product shall have a minimum lot area of 4,400 square feet and a minimum lot width of 42 feet.

Permitted uses: Detached single family dwelling units

Institutional uses

Entry features & monuments

Minor utilities

Open space

Parks

Patio homes

Recreational facilities

Religious assembly

Single family homes

Temporary uses

Home occupation

Minimum Lot Area: 4,600 square feet

Minimum Lot Width: 42 feet at the building setback line

Minimum Setbacks:

Front: 20 feet if front loaded

10 feet if rear loaded

5 feet for lots that front on a common area

Rear: 5 feet if front loaded

20 feet if rear loaded

20 feet for lots that front on a common area

Side: 5 feet

Corner: 10 feet

Architectural features may encroach into the setback area a maximum of three (3) feet and may not extend more than five (5) feet above the principal structure.

Plan of Development

Maximum Building Height: Two (2) stories or 35-feet.

Parking Requirement: Shall comply with the parking standards established in this section.

Buildings shall be separated by a minimum of ten (10) feet.

Each dwelling unit shall be platted on an individual lot.

Single family and patio homes shall comply with the standards established in their respective categories.

8. Multi-Family (MF)

Purpose: The Multi-Family category is intended for the development of medium to high density multi-family dwelling units such as apartments and condominiums.

- Permitted uses:
- Attached multi-family dwelling units
 - Attached single family dwelling units
 - Detached single family dwelling units
 - Detached multi family dwelling units
 - Condominiums
 - Institutional uses
 - Entry features & monuments
 - Minor utilities
 - Open space
 - Parks
 - Patio homes
 - Recreational facilities
 - Religious assembly
 - Single family homes
 - Temporary uses
 - Townhomes
 - Home occupations

Minimum Setbacks:

Front: 25 feet from property line

Plan of Development

Rear:	15 feet for habitable structures
	10 feet for accessory structures
Side:	10 feet for habitable structure
	10 feet for accessory structures

Architectural features may encroach into the setback area a maximum of three (3) feet and may not extend more than five (5) feet above the principal structure.

Parking Requirement: Shall comply with the parking standards established in this section.

Additional Requirements: Single family homes, patio homes and townhomes shall comply with the standards established in their respective categories.

9. Commercial (C)

Purpose: The Commercial District is intended for the development of service- oriented retail that meets the daily needs of the community.

Permitted uses:	Abstract or title company
	Advertising agency
	Antique store
	Art gallery
	Arts and crafts store
	Automated Car Washes (e.g., Blue wave, I-shine, White Water)
	Automobile repair, minor, no outside work or storage, except for national chains (e.g., Crash Champions)
	Bakery
	Banks and financial institutions, including drive-through and outdoor ATM facilities
	Barber or beauty shop
	Bookstore
	Cafeteria
	Candy store
	Catering
	Cellular phone sales and repair store

Plan of Development

Childcare facilities
Clothing store (no re-used clothing)
Collection agency
Computer sales and repair store
Community centers
Convenience store with or without gasoline, liquor or beer and wine sales
Dance studio
Delivery service
Dental clinic
Department store
Drafting service
Drug store, with or without liquor or beer and wine sales
Dry cleaning storefront, but not dry-cleaning plant
Electronic sales and repair store
Entry features & monuments
Filling station or service station, including oil change and inspection services
Florist shop
Furniture store
Gift shop
Gun shop
Grocery store
Hardware store
Home appliance store
House wares and linens store
Ice retail distributing, but not manufacturing
Institutional uses
Insurance agency

Plan of Development

Jewelry store

Laundry storefront, but not laundry plant

Locksmith

Medical clinic

Medical supply store

Minor utilities

Mixed uses (a mixture of uses consistent with this category; not the same as the Mixed Use Zone defined in Subsection 11 below.)

Mortgage company

Motels and Hotels; provided that Motels must be approved through a specific use permit

Motion picture theater, with or without food service, but not drive-in theater

Musical instrument store

Office supply and machinery store and repairs

Open space

Optician or optometrist

Parks

Personal services

Pharmacy

Professional office

Public Facilities

Public safety site

Radio sales and repair

Radio studio (excluding tower)

Record and tape store

Recreational Facilities

Religious assembly

Restaurants and taverns, with or without drive-through facilities

Plan of Development

Self-Storage
Shoe store and repair shop
Sporting goods store
Studio (art, music or photo)
Taxidermist
Tailor
Temporary uses
Toy store
Travel agency
Tree farms
Video arcade

Non-Permitted uses:

Auction
Billboards
Cemeteries
Feed store
Kennel (commercial)
Massage parlors
Pawn shop
Self-service car wash
Sexually oriented businesses
Swap meet
Tattoo shop
Taxidermist
Upholstery shop

Minimum Lot Area: 6,000 square feet

Minimum Lot width: 80 feet

Max. Lot coverage: 85 percent

Minimum Setbacks:

Plan of Development

Front:	25 feet
Rear:	10 feet
Side:	10 feet
Corner:	10 feet

Architectural features may encroach into the setback area a maximum of three (3) feet.

Setbacks for commercial land uses will be considered minimum setbacks and allow for the siting of commercial structures per the Unified Development Code (Section 3.5.3.1).

Maximum Building Height: Thirty-five (35) feet unless otherwise approved by City Council. All building area above two (2) stories shall be non-habitable and built with non-combustible material unless approved by the Fire Marshall; provided, however, that distribution centers or logistic centers may have a maximum of fifty (50) feet in height. .

Parking Requirement: Shall comply with the parking standards established in this section.

Commercial building materials and transparency/materials coverage requirements will be dictated through separate commercial guidelines as developed and enforced by Developer and any Architectural Review Committee they or the HOA may establish to govern and enforce said guidelines.

Additional Conditions: Outdoor Display of Merchandise shall be allowed within ten (10) feet of the primary building but shall be limited to merchandise that is customarily sold inside the establishment.

10. Institutional (I)

Purpose: The Institutional category is intended to provide for the development of public and private uses that serve the community.

Permitted uses:	Major utilities
	Minor utilities
	Not for profit hospitals
	Open space
	Parks
	Places of worship
	Public facilities
	Public safety site
	Recreational facilities

Plan of Development

- Religious assembly
- Schools (public & private)
- Telecommunication towers
- Temporary uses
- Tree farms

Minimum Lot Area: 5,000 square feet

Minimum Lot width: 50 feet

Minimum Setbacks:

- Front: 25 feet
- Rear: 10 feet
- Side: 5 feet
- Corner: 5 feet

Architectural features may encroach into the setback area a maximum of three (3) feet.

Maximum Building Height: 60 feet. All building area above two (2) stories shall be non-habitable and built with non-combustible material unless approved by the Fire Marshall.

Parking Requirement: Shall comply with the parking standards established in this section.

Additional Requirements: Telecommunication towers may not exceed eighty (80) feet in height and shall be set back from property lines a distance equal to or greater than the height of the tower.

Commercial building materials and transparency/materials coverage requirements will be dictated through separate commercial guidelines as developed and enforced by the Developer and any Architectural Review Committee they or the HOA may establish to govern and enforce said guidelines.

11. Mixed-Use (MU)

Purpose: Mixed-Use (MU) lots are intended to provide flexibility through the design process. Permitted uses are residential, commercial, and institutional, and the regulations are as defined in the corresponding categories.

- Permitted uses:
- Attached multi-family dwelling units
 - Attached single family dwelling units
 - Detached single family dwelling units
 - Detached multi family dwelling units

Plan of Development

- Condominiums
- Institutional uses
- Entry features & monuments
- Minor utilities
- Open space
- Parks
- Patio homes
- Recreational facilities
- Religious assembly
- Single family homes
- Temporary uses
- Townhomes
- Home occupations
- All commercial uses as defined above

Minimum Setbacks:

- Front: 25 feet from property line
- Rear: 15 feet for habitable structures
10 feet for accessory structures
- Side: 10 feet for habitable structure
10 feet for accessory structures

Architectural features may encroach into the setback area a maximum of three (3) feet and may not extend more than five (5) feet above the principal structure.

Parking Requirement: Shall comply with the parking standards established in this section.

Additional Requirements: Single family homes, patio homes and townhomes shall comply with the standards established in their respective categories.

12. Parks & Open Space (P-OS)

Purpose: The Parks & Open Space category is intended to provide for the development of recreation and open space areas within the community.

Permitted uses: Community centers

Plan of Development

- Drainage ponds and channels
- Drill site
- Entry features & monuments
- Institutional uses
- Minor utilities
- Open space
- Parks
- Pipeline easements
- Public facilities, excluding major utilities
- Recreational facilities
- Temporary uses
- Tree farms

Minimum Lot Area: None

Minimum Lot width: None

Minimum Lot depth: None

Minimum Setbacks:

- Along Major Thoroughfares: 25 feet
- Along other streets: 10 feet
- Rear: 10 feet
- Side: 10 feet

Architectural features may encroach into the setback area a maximum of thirty-six (36) inches.

Max. Building Height: 35 feet. Maximum height may exceed 35 feet if approved by the Fire Chief.

Parking Requirement: Shall comply with the parking standards established in this section.

13. Industrial (IND)

Purpose: The Industrial category is intended to provide for the development of industrial property within the community.

- Permitted uses:
- Industrial Distribution and/or Industrial Logistics
 - Light Industrial (e.g., Office Warehousing)

Telecommunication towers

Additional Requirements: Telecommunication towers may not exceed eighty (80) feet in height and shall be set back from property lines at a distance equal to or greater than the height of the tower.

Plan of Development

13. Parking

Parking within the Project shall be provided according to the following schedule:

TABLE 3	
Parking Requirements	
Land Use	Minimum Requirement
Single family residential	2 enclosed spaces per unit
Patio home	2 enclosed spaces per unit
Townhome	2 enclosed spaces per unit 0.25 guest spaces per unit
Multi-Family	1.333 spaces per 1-bedroom unit
	1.666 spaces per 2-bedroom unit
	2.0 spaces per unit with 3 or more bedrooms
Office (non-medical)	1 space per 250 square feet of gross floor area
Medical office	4 spaces per 1000 square feet of gross floor area
Retail	Under 400,000 sf: 4 spaces per 1000 square feet of gross floor area
Restaurant	400,000 sf and over: 5 spaces per 1000 square feet
Tavern	1 space per 45 square feet of gross floor area
Hotel/Motel	1 space per room
Theater/Auditorium/Church/Assembly Hall	0.25 spaces per seat
Stadium	1 space per 4 stadium seats

Deviations from the above requirements shall be considered by the City’s Designated Official on a case-by-case basis. Appeals to the Official’s interpretation may be made to City Council within thirty (30) days of the date of the determination.

The City’s Designated Official shall determine the minimum number of parking spaces required for any use not specified above. Appeals to the Official’s interpretation may be made to City Council within thirty (30) days of the date of the determination.

Shared parking should be encouraged where appropriate. Adjustment of the minimum number of parking spaces required to serve a combination of occupancies shall be determined according to the following formula:

- 1) Determine the parking requirement for each occupancy as though it were a separate use;
- 2) Multiply each amount by the corresponding percentage for each applicable time period shown in the following schedule:

Plan of Development

TABLE 4					
Shared Parking Table					
Use	Weekdays			Weekends	
	Night Midnight – 6 a.m.	Day 9 a.m. – 4 p.m.	Evening 6 p.m. - Midnight	Day 9 a.m. – 4 p.m.	Evening 6 p.m. - Midnight
Retail	5%	50%	90%	100%	70%
Hotel/Motel	80%	80%	100%	80%	100%
Office	5%	100%	10%	10%	5%
Restaurant / Tavern	10%	50%	100%	50%	100%
Entertainment / Recreation	10%	40%	100%	80%	100%
All Others	100%	100%	100%	100%	100%

- 3) Calculate the column total for each time period; and
- 4) The column with the highest value shall be the parking requirement.

D. Definitions

Accessory structure – any above ground structure that is (1) incidental to and customarily associated with the main structure on the site, and (2) located on the same lot as the principal building. Accessory structures may include, but are not limited to, detached garages and gazebos, but does not include utility or storage sheds.

Alley – a public or private right-of-way that provides vehicular access to buildings or properties that front on an adjacent street.

Architectural feature – an ornamentation or decorative feature attached to or protruding from the exterior wall of a building. Architectural features may include, but are not limited to, windows (e.g., bay windows), chimneys, columns, awnings, marquees, façade, or fascia.

Attached housing – a building containing two or more dwelling units.

Banking or financial institution – a chartered financial institution that engages in deposit banking and closely related functions such as making loans, investments, and other fiduciary activities. Drive-up windows and drive-thru automated teller machines (ATM) are permitted as an accessory use.

Block length – the distance measured along a street between two intersecting streets.

Building – a structure used for or supporting any use or occupancy that requires a building permit.

Child care facility – a commercial or non-profit facility that provides shelter, care, activity, and supervision of children for periods of less than 24 hours a day and is licensed by the state.

Community center – a meeting place used by the community in which community members may gather for social, educational, recreational, or cultural activities. Uses include recreation, fitness center, meeting areas, and restaurants with or without alcohol sales. Community center use may be restricted to dues paying members.

Condominium – A single dwelling unit in a multi-unit dwelling or structure, which is separately owned and which may be combined with an undivided interest in the common areas and facilities of the property.

Convenience store – Any retail establishment offering for sale gasoline and a limited line of groceries and household items intended for the convenience of the neighborhood. Automotive washing is permitted as an accessory use. The sale of alcohol is permitted as an accessory use.

Council – Shall mean the City Council of the City of Iowa Colony.

Cul-de-sac - Any street with only one outlet that terminates in a vehicular turnaround.

Designated Official – The individual authorized by the City of Iowa Colony to provide direction and oversight and personally perform duties related to a comprehensive program to protect the

Plan of Development

health and safety of citizens and the quality of life by ensuring that planning activities meet appropriate codes, standards and city ordinances.

Detached housing – A site-built building containing only one dwelling unit.

Drill site – A tract of land designated for the purpose of extracting oil or gas comprising a “spacing unit “or “proration unit” as determined by the State Railroad Commission.

District – One or more special water districts to be created on the Property which will operate under the authority of Article III, Section 52 and Article XVI, Section 59 of the Texas Constitution and Chapters 49 and 54 of the Texas Water Code, and/or chapter 375 of the Local Government Code, together with all amendments and additions thereto. The term specifically shall include a municipal utility district or a municipal management district.

Dwelling unit - Any building or portion thereof which is designed or used exclusively for residential purposes.

Entry features – Primary points of vehicular entry into the Property that are enhanced with landscaping, water features, architectural treatments, and lighting.

Front loaded – Any dwelling unit that takes vehicular access from the street on which it fronts.

Frontage – Frontage shall mean that portion of any lot or tract that abuts a street or approved common area. A lot or tract abutting more than one street shall have frontage on only one street which shall be deemed to be the side having the shortest dimension unless otherwise indicated on the subdivision plat.

General development plan – A plan illustrating all contiguous property under one ownership, legal interest, or common control that identifies the major thoroughfares and collector streets that are necessary to demonstrate an overall circulation system for the property, any recorded easements that affect the property and proposed land use.

Grocery store – A retail establishment primarily selling prepackaged and perishable food as well as other convenience and household goods. The sale of alcohol is permitted as an accessory use.

Gross acreage – Gross acreage shall mean the total area of land inclusive of all encumbrances, including, but not limited to, rights-of-way, drainage ways, pipeline and utility easements, detention facilities, parks and open space areas.

Gross density – A measurement of density based on the calculation of the total gross acres within a subdivided area divided by the total number of dwelling units within that area.

Home occupation – An occupation or activity which is clearly incidental and secondary to use of the premises as a dwelling and which is carried on wholly or in part within a main building or accessory building by a member of the family who resides on the premises. A home occupation use shall not change the residential character of the property or the neighborhood and shall

Plan of Development

meet all applicable legal requirements. A home occupation may not display signage on the property. No more than one (1) employee may reside off-premises.

Home owner's association (HOA) – A non-profit corporation, established for the purpose of managing and maintaining community property and services within a subdivision. All residential property owners within the subdivision shall be a member of the HOA for that subdivision.

Institutional use – A use designated for public facilities including, but not limited to major and minor utilities, public safety sites, libraries, schools (both public and private), hospitals, churches or other places of worship, and other civic uses.

Knuckle – The projection toward the outside corner of a bend in the right-of-way of that allows for adequate turning movements for emergency and other vehicles.

Landscaping – Planting and related improvements for the purpose of beautifying and enhancing a portion of land and for the control of erosion and the reduction of glare, dust and noise. Rocks and/or gravel, by itself shall not constitute landscaping.

Laundry services (including dry cleaning) – A facility that launders or dry cleans articles dropped off on the premises directly by the customers or where articles are dropped off, sorted, and picked up, but where laundering is done elsewhere.

Local street - A public street that is not a major thoroughfare or collector and conforms to the criteria established in this Plan of Development.

Lot – An undivided tract of land having frontage on a public or private street which is designated as a separate and distinct tract and identified by numerical identification on a duly and properly recorded subdivision plat.

Major arterial – A public street designated as a Major Arterial on the City's Thoroughfare Plan.

Major collector – A public street designated as a Major Collector Street on the City's Thoroughfare Plan.

Major utility – Uses or structures providing utility services that have a potential major impact by virtue of appearance, noise, size, traffic generation or other operational characteristics, which include, but are not limited to, transmission substations, wastewater treatment facilities, water reservoirs and pump stations, wastewater lift stations, and power plants. This use does not include private individual water supplies or septic tanks. See Minor Utilities.

Minor utility – Small scale facilities that are necessary to support development and that involve only minor structures. Minor utilities include, but are not limited to facilities such as power lines, water and sewer lines, storm drainage facilities, transformers, hydrants, switching boxes and similar structures.

Mixed-use – A tract of land, building, or structure developed for two or more different uses such as, but not limited to, residential, office, retail, public, or entertainment. The mix of uses may occur either on the same tract of land, but compartmentalized into separate buildings, or

Plan of Development

located within the same building (e.g., retail on the first floor and office or residential on the floors above the retail).

Neighborhood – A collection of compatible subdivisions.

Minor collector – A public street that is not a major arterial, or major collector street and is designed to help distribute traffic within residential areas.

Open space – A portion of land designated as open space on the Preliminary Land Use Plan. Open space areas shall include pipeline and utility easements, drainage ways, and wet and dry detention areas.

Patio home - A single-family residence which has a zero (0) foot side setback on one of the side lot lines.

Personal services – Establishments providing non-medical related services generally related to personal needs, including beauty and barber shops, day spas, garment and shoe repair shops, laundry services (including dry cleaning), photographic studios, dance studios, and health clubs. These uses may include the accessory retail sales of products related to the services provided.

Personal storage – An area used or intended for the storage of materials, vehicles or equipment not in service.

Private – Elements of the development that are not intended for public use and are operated and maintained by a private entity.

Private street - A street that is privately owned and maintained. Private streets may be gated.

Private utilities – Utilities other than water and wastewater. Other utilities may be public and/or private in nature and may include, but are not limited to electrical power, gas, telephone, wireless communication, internet and cable television.

Professional office - A room or group of rooms used for conducting the affairs of a business, medical, professional, or service industry.

Project – The development that is planned for the Project Property and is governed this Plan of Development.

Project Property/Property – The approximately 900 acres of land that constitutes the entire Project which is the subject of this Plan of Development.

Property owner's association (POA) – A non-profit corporation, established for the purpose of managing and maintaining community property and services within a commercial development.

Public facilities – Any non-commercial land use (whether publicly or privately owned) which is to be used and/or allocated for the general good of the public. These uses include, but are not limited to, governmental offices, libraries, parks, and major and minor utilities.

Public safety site – A tract of land containing a building or structure that is designated for police, fire, or emergency services.

Plan of Development

Public utilities – Any utilities that are provided by the city, county, or municipal utility district which may include, but are not limited to water and wastewater.

Quad – A specialty type residential land use/product that employs four single family residential units on reduced lot sizes centered on a shared drive. Garage access to these units will be taken from the shared drive in order to reduce overall number of curb cuts/driveways within these sections and to promote a greater uninterrupted pedestrian realm for those residents.

Recreational facilities – Any structure or building intended for active recreational use. Recreational uses shall include, but are not limited to clubhouses, tennis courts, basketball courts, sports fields, pools, playground equipment, bleachers, spray-grounds, dog parks, yard games, etc.

Religious assembly – A building or group of buildings used or proposed to be used for conducting organized religious services and accessory uses directly associated with the use.

Restaurant (including carry-out and drive-thru) – A commercial establishment where food and beverages are prepared for consumption either on or off the premises. The sale of alcohol is permitted.

Retail – Retail sales of any article, substance, or commodity within a building or structure.

School (public or private) – An institution for the teaching of children or adults including primary and secondary schools, colleges, professional schools, art schools, trade schools, and similar facilities.

Shared parking – The use of the same off-street parking stall or stalls to satisfy the off-street parking requirements for two or more individual land uses without significant conflict or encroachment.

Subdivision – The division of a lot, tract, or parcel of land into two or more lots, plats, sites or other divisions of land for the purpose of residential, industrial, office and business development or other uses.

Telecommunication tower – A structure on which there are electronic facilities for receiving or transmitting communication signals.

Temporary use – Any use allowed for a specific period of time. A use that is not of a permanent nature.

Theater – An outdoor or indoor area or building used for dramatic, operatic, motion pictures, or other performances.

Townhome - One (1) of a group of attached single family residences separated by a fire rated wall. Each dwelling unit shall be platted on an individual lot.

Wastewater treatment facilities – Any facility used for the treatment of commercial and residential wastewater for sewer systems and for the reduction and handling of solids and gasses removed from such wastes.

Maple
Farms

The City of Iowa Colony

Plan of Development

Water plant facilities – Any facility used for the collection, treatment, testing, storage, pumping, or distribution of water for a public water system.

IV. GENERAL ADMINISTRATION & AMENDMENTS

A. Purpose

This section establishes guidelines regarding the administration and future amendments to the Plan of Development.

B. Changes to the Code of Ordinance

The Development Regulations section of the Plan of Development addresses only those areas that differ from the existing City of Iowa Colony Code of Ordinances. In the event that an issue, condition, or situation arises that is not specifically addressed in the Plan of Development, the City of Iowa Colony Code of Ordinances in place at the time of the adoption of this document shall be used by the City's Designated Official as the basis to resolve the issue.

C. Variances from the Subdivision Ordinance, Unified Development Code, and Zoning Ordinance

The criteria established in this Plan of Development require variances from the City of Iowa Colony Subdivision Ordinance, the City of Iowa Colony Zoning Ordinances, and the Unified Development Code. . These variances are necessary to achieve the community vision established for the Project. Table 5 (and Section III(6) of the Plan of Development pertaining to Drill Sites) describes the requested variances from the subdivision ordinance and their corresponding sections. Table 6 describes the requested variances from the Unified Development Code and their corresponding sections. Table 7 describes the requested variances from the City of Iowa Colony's Zoning Ordinances and their corresponding sections. These variances shall apply to all property within the Plan of Development.

D. Variances from the Design Manual

The criteria established in this Plan of Development require variances from the City of Iowa Colony Engineering Design Criteria Manual (EDCM). These variances are necessary to achieve the community vision established for the Project. Table 8 describes the requested variances and their corresponding section of the design manual. These variances shall apply to all property within the Plan of Development.

TABLE 5
Subdivision Ordinance Variances

Ordinance Reference	Requirement	Proposed	Difference	Justification
Sec. 22 Final Plat Procedure (31)	In the event the tract of land being subdivided fronts on a street or road that does not meet the city's design specifications, the subdivider shall be required to improve the street or road to meet those specifications from a street or road that does meet the city's requirements, to the farthest boundary of the subdivision.	The developer would dedicate any additional right-of-way required for adjacent streets or roads, but shall not be required to make any paving, drainage, or utility improvements along said roads. The MUD will carry the escrow to construct any future road segments within the development when a connecting roadway project is planned at the project boundaries.	Additional right-of-way will be dedicated for these facilities, but no improvements will be made at this time.	The cost to bring these roads up to the city's specifications would not be proportionate to the impact that this development will have on these facilities. In addition, it is not practical to only improve a small segment of a road. The necessary right-of-way will be dedicated so these facilities may be improved at the appropriate time.
Sec. 27 Planned Unit Developments (D)	The minimum size of a Plan of Development shall be 20 acres and not less than 5 percent of the total area shall be set aside as common landscaped areas. Utility easements, drainage easements, and detention basins shall not be included in calculating the 5 percent requirement.	Open space areas shall include pipeline and utility easements, drainage ways and wet and dry detention areas.	Open space areas shall include pipeline and utility easements, drainage ways and wet and dry detention areas.	Open space is a central theme of the Project. Drainage ways, detention areas and easements will be utilized as greenbelts that connect the entire community and therefore, should be considered as an amenity.
Sec. 27 Planned Unit Developments (E)	The minimum lot width of all residential lots to be located within a Plan of Development shall be 60 feet.	<p>The minimum lot width for traditional single family lots shall be 40 feet.</p> <p>The minimum lot width for patio home lots shall be 40 feet.</p> <p>The minimum lot width for townhome lots shall be 19 feet.</p> <p>The minimum lot width for quad lots shall be 120 feet for the four-pack.</p> <p>The minimum lot width for alley product lots shall be 42 feet.</p>	<p>20-foot reduction in width for traditional single-family dwellings.</p> <p>15-foot reduction in width for patio homes</p> <p>41-foot reduction in width for townhomes.</p>	Allowing reductions in minimum lot width and area is necessary in order to achieve a variety of housing products which is an essential component of healthy and sustainable communities.
Sec. 33 Streets (Clarification)	The minimum right-of-way for local streets shall be 60 feet	Local streets shall have a minimum right-of-way of 50 feet	10-foot reduction in right-of-way width. 10-foot utility easements will be provided on both sides of the right-of-way. Paving section shall remain 28 feet.	The street paving section shall remain 28 feet and thus will have no effect on traffic circulation. 10-foot utility easements will be provided where necessary for utility maintenance. Reduction in right-of-way width allows for the preservation of more open space.

Sec. 33 Streets, Minimum right-of-way	The minimum right-of-way for residential streets shall be 60 feet.	Residential streets providing access to lots may have a right-of-way width of 50 feet.	10-foot reduction in right-of-way width. 10-foot utility easements will be provided on both sides of the right-of-way. Paving section shall remain 28 feet.	The street paving section shall remain 28 feet and thus will have no effect on traffic circulation. 10-foot utility easements will be provided where necessary for utility maintenance. Reduction in right-of-way width allows for the preservation of more open space.
Sec. 33 Streets, Minimum right-of-way	The minimum right-of-way for residential streets shall be 60 feet.	Type 1 Private Streets shall have a right-of-way of 50 feet.	10-foot reduction in right-of-way width. 10-foot utility easements will be provided on both sides of the right-of-way. Paving section shall remain 28 feet.	The street paving section shall remain 28 feet. Type 1 Private Streets will be privately maintained and may be gated. The right-of-way for Type 1 Private Streets shall be identified as a Public Utility Easement in order to allow for public utility service.
Sec. 33 Streets, Minimum right-of-way	The minimum right-of-way for residential streets shall be 60 feet.	Type 2 Private Streets shall have a right-of-way of 28 feet.	22-foot reduction in right-of-way width. Paving section shall remain 28 feet.	The street paving section shall remain 28 feet. Type 2 Private Streets will be privately maintained and may be gated. The right-of-way for Type 2 Private Streets shall be identified as a Public Utility Easement in order to allow for public utility service.
Sec. 33 Multiple Access Points (E) (clarification)	All subdivisions, except those with single dead-end streets, shall have a minimum of two access points to existing (or future) public streets.	All subdivisions shall provide a minimum of two points of access. A divided or boulevard entry shall be considered two points of access for these purposes provided that the divided paving section extends to the first intersecting street. A boulevard shall be acceptable where a second access is not available.	Clarification that a boulevard entry shall be considered two points of access in all cases.	N/A
Sec. 33 Right-of-way widths (K)	All street rights-of-way widths shall be not less than 60 feet.	50-foot local streets 50-foot private streets (Type 1) 28-foot private streets (Type 2)	10 feet R.O.W. reduction, no reduction in paving 10 feet R.O.W. reduction, no reduction in paving 22 feet R.O.W. reduction, no reduction in paving	Project will feature a variety of street types that are designed to serve the variety of land uses and product types within the Project.
Sec. 33 Dead End Streets (M)	Dead-end streets, designated to be so permanently, shall not be longer than 1200 feet and shall be provided at the closed end with a turn-around having an outside roadway diameter of at least eighty (80) feet and a street property line diameter of at least one hundred (100) feet.	Type 2 private streets may extend up to 200 feet without a turnaround. Dead end Type 2 private streets that exceed 200 feet in length shall provide an adequate turnaround.	N/A	This requirement conforms with fire code regulations and is appropriate given the nature of the street type.

Sec. 33 Street Design (N)	The details of all street designs shall conform to the city's engineering standards and standard details.	The Plan of Development has established certain street criteria that will apply to streets within this Project in addition to the city's standards.	Clarification that streets within this Project shall be designed to meet both sets of criteria.	N/A
Sec. 34 Alleys (B)	The width of alleys within commercial and industrial districts shall be at least 20 feet. The width of alleys within residential districts shall be at least 20 feet where possible; however, a minimum width of 16 feet may be allowed.	In addition to public alleys, the Project may contain private alleys. Private alleys shall have a minimum right-of-way width of 20 feet with a 14-foot paving section.	Any public alleys shall meet the minimum standard.	Private alleys shall be privately maintained.
Sec. 34 Alleys (D) (clarification)	Dead-end alleys shall be avoided where possible but when unavoidable, adequate turnaround facilities at such dead end shall be provided.	Dead-end alleys will be avoided but may be necessary or more desirable in certain circumstances. Dead-end alleys greater than 150 feet in length shall provide an adequate turnaround.	Clarification that a dead-end alley may be avoidable, but undesirable and therefore permitted provided that the dead-end does not exceed 150 feet in length.	The fire code allows for dead-end access without a turnaround up to 150 feet in length.
Sec. 36 Blocks (D)	No block shall exceed 1,200 feet in length in residential or commercial developments.	The maximum block length for major thoroughfares shall be 2,600 feet except where the thoroughfare runs parallel to a drainage feature having a minimum width of 50 feet which may have a maximum block length of 4,000 feet. The maximum block length for collectors and neighborhood collectors shall be 1,800 feet and the maximum block length for local streets shall be 1,200 feet. Crossings of bayous or canals shall only be required by streets that are identified as major corridors on the City's Thoroughfare Plan. The maximum block length along pipeline easements and drainage features having a minimum width of 50 feet shall be 2,000 feet.	1,400 additional feet on major thoroughfares. 2,800 additional feet for major thoroughfares that run parallel to drainage features with a minimum width of 50 feet. 600 additional feet for collectors and neighborhood collectors. 800 additional feet along pipelines and drainage features.	Generally, intersections along major thoroughfares and collectors should be spaced farther apart than along local streets. This allows for more efficient traffic flow and limits pedestrian/auto conflicts. Pipelines and drainage features represent physical encumbrances that warrant additional spacing standards.
Sec. 37 Lots (B) Lots Smaller Than One Acre #1	Minimum front setback lines shall be at least twenty-five (25) feet. Each corner lot shall have at least the minimum front residential setback line on both streets.	The minimum front setback for all single-family lots and all cul-de-sacs and knuckles shall be 20 feet. Corner lots shall have a minimum side setback of 10 feet. Porches may encroach into the front setback up to 10 feet provided they have a minimum depth of 6 feet. On corner lots, porches may encroach into the side setback up to 5 feet provided they have a minimum depth of 6 feet. Where garages face directly onto a street, the garage must be setback a minimum of 20	5-foot reduction for front setbacks for lots. 10-foot reduction for porches having a minimum depth of 6 feet. 15-foot reduction for side-entry garages. 15-foot reduction for side setbacks on corner lots.	Reduced setbacks foster a pedestrian friendly environment and encourage neighbor interaction. Porches and varying building lines create interest along the street and help to achieve a more attractive street scene.

		feet. Side-entry garages must be set back a minimum of 10 feet.		
Sec. 37 Lots (B) Lots Smaller Than One Acre #6	Double and reverse frontage lots. Double frontage and reverse frontage lots should be avoided unless backing up to a major thoroughfare.	Double and reverse frontage lots may be permissible on alley products and/or quads.	Double and reverse frontage lots may be permissible on alley products and/or quads.	A greater variety of housing products is a necessary component in achieving a healthy and sustainable community.
Sec. 37 Lots (B) Lots Smaller Than One Acre #8	Flag and key shaped lots. No flag or key-shaped lots are allowed.	Flag and/or key shaped lots are allowed in specialty product.		A greater variety of housing products is a necessary component in achieving a healthy and sustainable community.
Sec. 37 (B) Lots Smaller Than One Acre #2	Lot Dimensions. Regardless of any other provisions of this Ordinance, lot dimensions shall be a minimum of sixty (60) feet in width at the building setback line and of a depth so as to provide an area of not less than six thousand three hundred (6,300) square feet.	<p>The minimum lot width for traditional single family lots shall be 40 feet with a minimum area of 4,600 s.f.</p> <p>The minimum lot width for patio home lots shall be 40 feet with a minimum area of 4,400 s.f.</p> <p>The minimum lot width for townhome lots shall be 19 feet with a minimum area of 1,900 s.f</p> <p>The minimum lot width for quads shall be 120-feet for the four-pack with a minimum area of 3,500 s.f.</p> <p>The minimum lot width for alley products shall be 42 feet with a minimum area of 4,600 s.f.</p>	<p>20-foot reduction in width and 1,700 s.f. reduction in area (traditional single family)</p> <p>20-foot reduction in width and 1,900 s.f. reduction in area (patio homes)</p> <p>41-foot reduction in width and 4,400 s.f. reduction in area (townhomes)</p> <p>N/A</p> <p>18-foot reduction in width and 1,700 s.f. reduction in area (alley product)</p>	Allowing reductions in minimum lot width and area is necessary in order to achieve a variety of housing products which is an essential component of healthy and sustainable communities.
Sec. 37 (B) Lots Smaller Than One Acre #5	Access to public streets. The subdividing of the land shall be such as to provide each lot with satisfactory access to a public street.	Each single-family lot shall have frontage on a local street, private street, or common area. When lots front on a common area, vehicular access must be provided by a local street, private street, or alley.	Lots will have satisfactory access by one of multiple means.	All lots shall have adequate access. Allowing for a variety of street "scenes" will enhance the overall "look and feel" of the community. The proposed means of access allow for safe and efficient vehicular and emergency access.
Sec. 40 Additional Street Requirements (B)	The developer shall be responsible for construction of all roadways within the development according to minor street standards. Where the major Thoroughfare Plan requires street widths over and above the local street requirements, the developer shall dedicate the right-of-way required for the larger street and construct up to a thirty-eight (38) foot wide pavement. If the City requires a pavement wider than the thirty-eight (38) feet, the City shall provide funding for the increased width subject to the	The developer shall bear the cost of all streets within the Project. The entire cost of thoroughfares, collectors, and local streets shall be eligible for reimbursement by the MUD.	The developer will build all necessary streets within the Project and the city will not have to fund any street improvements.	The developer will build all necessary streets within the Project and the City will not have to fund any street improvements.

	availability of funds and within legal limitations.			
Sec. 40 Additional Street Requirements (C)	The developer shall be responsible for construction of necessary improvements on all perimeter streets to bring the pavement and curbing up to minor street standards for the street abutting the development.	The developer would dedicate any additional right- of-way required for adjacent streets or roads, but shall not be required to make any paving, drainage, or utility improvements along said roads. The MUD will carry the escrow to construct any future road segments within the development when a connecting roadway project is planned at the project boundaries.	Additional right-of-way will be dedicated for these facilities, but no improvements will be made at this time.	The cost to bring these roads up the city's specifications would not be proportionate to the impact that this development will have on these facilities. In addition, it is not practical to only improve a small segment of a road. The necessary right-of-way will be dedicated so that these facilities may be improved at the appropriate time.
Sec. 42 Sidewalks	In large subdivisions, four (4) foot wide sidewalks shall be required and shall be constructed in accordance with the city's design criteria. If not constructed prior to issuance of a building permit, any sidewalks required by this article must be constructed as part of the issuance of a building permit for each tract.	Sidewalks adjacent to reserves or open space areas shall be constructed prior to the release of the construction maintenance bond for the appropriate section.	Sidewalks will be constructed prior to acceptance by the city rather than the issuance of building permits.	Sidewalks are frequently damaged during the home construction process. Allowing sidewalks to be put in after permitting is more efficient, avoids unnecessary damage and achieves the desired result.

TABLE 6
Unified Development Code Variances

Unified Development Code Reference	Requirement	Proposed	Difference	Justification
Section 3.1.2.6.C	The planting scheme for street trees shall be such that no street tree is planted closer than twenty feet (20') to any other street tree (whether an existing tree or a tree planted hereunder) with the trees being spaced without extreme variation in distance across each block face frontage taking into account existing site conditions and driveway locations.	Closer than 20' feet	Closer than 20' feet	By diversity of street trees an increased biodiversity, habitat creation, and naturalistic planting areas will be created throughout the development for the added benefit and use of future residents and fauna.
Section 3.2.1.3.E	Identification of the required amount of parkland is to be indicated on an approved subdivision plat.	Identification of the required amount of parkland is to be indicated in this document.	Identification of the required amount of parkland is to be indicated in this document.	The parks, open space and trails plan will define the required parkland for the Project.
Section 3.2.1.6	In addition to the provisions for neighborhood parks by dedication of land (public or private) or the payment of fees in lieu thereof as described above, a developer shall contribute an additional four hundred fifty dollars (\$450.00) per dwelling unit for the development of regional parks.	The City may consider Regional Parkland land dedication in lieu of monetary contribution in the amount of \$450.00 per dwelling unit. This agreement shall only be approved by the City Council.	Parkland may be dedicated for regional purposes dependent upon further study by the City in their Master Parks Plan.	The open space and trails provide an exceptional amount of regional parkland that will be available for public use. Parkland may be dedicated for regional purposes dependent upon further study by the City in their Master Parks Plan.
Section 3.5.3.1.A.1	If the property frontage is not on a designated super arterial or major arterial, the front wall of the building shall be located on a build-to building setback line located ten (10) feet from the ultimate right-of-way line of the street along the front of the property	Commercial buildings shall be subject to setback lines only.	Commercial buildings shall be subject to setback lines only.	Allows for higher flexibility and more varying uses of commercial properties.
Section 3.5.3.1.A.2	If property frontage is on a designated super arterial, the front wall of the building shall be located on a build-to building setback line of seventy-one (71) feet from the ultimate right-of-way line of the street along the front of the property.	Commercial buildings shall be subject to setback lines only.	Commercial buildings shall be subject to setback lines only.	Allows for higher flexibility and more varying uses of commercial properties.
Section 3.5.3.7.A	Building height in Iowa Colony is restricted to a maximum of two (2) stories, but in no case more than thirty-five (35) feet from the natural ground elevation, as fire protection above that height is not now possible	Buildings height shall be a maximum of 3 stories.	Buildings height shall be a maximum of 3 stories.	Allows for higher flexibility and more varying uses of commercial properties.

TABLE 7
Zoning Ordinance Variances

Ordinance Reference	Requirement	Proposed	Difference	Justification
Section 56.B.7 Table 5	A minimum of 6 parking spaces per 1,000 s.f. (medical office)	A minimum of 4 parking spaces per 1,000 s.f. (medical office)	A reduction in 2 parking spaces per 1,000 s.f. (medical office)	Allows for higher flexibility and more varying uses of commercial properties.
Section 74.d.iii.A.1	Compensating open space must be reasonably dry and flat with no more than twenty-five (25) percent of the total required compensating open space to be located within the one hundred (100) year floodplain and/or within a non-permanent wet location of a drainage detention area	Compensating open space must be reasonably dry and flat with no more than fifty (50) percent of the total required compensating open space to be located within the one hundred (100) year floodplain and/or within a non-permanent wet location of a drainage detention area	Increase total compensating open space allowed within one hundred (100) year flood plain to fifty (50) percent.	Allows for greater use of natural elements to be used to full potential. Utilizing natural floodways will allow residential sections to access trail network and greenway.
Section 74.d.iii.A.iv	Any area with single-family residential lots less than five thousand (5,000) square feet in lot area shall provide a property owners association to maintain the front yard between the face of the front of the house structure and the front property line of each lot for the area containing single-family residential lots less than five-thousand (5,000) square feet in lot area	No Traditional Single Family Residential product shall have lots maintained by the HOA. However, townhomes and other specialty product lots shall have front lawn maintenance provided by the HOA.	Only townhomes and other specialty product lots shall have front lawn maintenance provided by the HOA	HOA will have set maintenance and landscape guidelines that will be enforced for Traditional Single Family Residential lots, and town homes and other specialty products shall have front lawn maintenance provided by the HOA.
Section 74.d.iii.A.vii	Any area with single-family residential lots less than sixty-six hundred (6,600) square feet in lot area shall have the primary residential structure constructed with the following minimum and maximum building floor area: Single-family lots, within a single-family residential lot area with lots less than sixty-six hundred (6,600) square feet in lot area, with a lot area between five thousand (5,000) square feet and sixty-six hundred (6,600) square feet require a minimum building floor area of twenty-four hundred (2,400) square feet (not including the attached garage area) and a maximum first floor building coverage of fifty (50) percent of the single-family residential lot area; single-family residential lots, within a single-family residential lot area with lots less than sixty-six hundred (6,600) square feet in lot area, between four thousand (4,000) square feet and five thousand (5,000) square feet require a minimum building floor area of twenty-five hundred (2,500) square feet (not including the attached garage area) and a	Traditional single family residential lots may have a maximum lot coverage of 60%. Patio Home residential lots may have a maximum lot coverage of 70%. Townhome residential lots may have a maximum lot coverage of 70%. Quad residential lots may have a maximum lot coverage of 70%. Alley residential lots may have a maximum lot coverage of 70%	Traditional single family residential lots may have a maximum lot coverage of 60%. Patio Home residential lots may have a maximum lot coverage of 70%. Townhome residential lots may have a maximum lot coverage of 70%. Quad residential lots may have a maximum lot coverage of 70%. Alley residential lots may have a maximum lot coverage of 70%	Allowing a greater variety of housing products and variation in maximum lot coverage is a necessary component to achieve a healthy and sustainable community.

	<p>maximum first floor building coverage of fifty (50) percent of the single-family residential lot area; single-family residential lots, within a single-family residential lot area with lots less than sixty-six hundred (6,600) square feet in lot area, with a lot area between thirty-five hundred (3,500) square feet and four thousand (4,000) square feet require a minimum building floor area of twenty-five hundred (2,500) square feet and a maximum first floor building coverage of forty-five (45) percent.</p>			
Section 74.d.iii.2.a	<p>Any single-family residential lot, within a single-family residential lot area with less than sixty-six hundred (6,600) square feet in lot area, with a lot area less than sixty-six hundred (6,600) square feet in lot area but at least thirty-five hundred (3,500) square feet in lot area shall have a minimum twenty (20) feet building setback from the rear lot line unless the lot has rear alley access which shall require a minimum of twenty-four (24) feet between the face of the garage door and the opposing alley paving edge line or any other fence or structure and a minimum of three (3) feet rear building line for any other structure. If the driveway connection between the rear-loaded garage and the alley is to provide required on-site parking, the minimum rear building setback line for the garage is twenty (20) feet.</p>	<p>A traditional single-family residential lot shall have a minimum 10-foot rear building setback.</p> <p>Patio homes shall have a minimum 10-foot rear building setback.</p> <p>Townhomes shall have a minimum 5-foot rear building setback.</p> <p>Quads shall have a minimum 5-foot rear building setback.</p> <p>Alley product shall have a minimum 5-foot rear setback if front loaded and shall have a minimum 20-foot rear building setback if rear loaded.</p>	<p>A traditional single-family residential lot shall have a minimum 10-foot rear building setback.</p> <p>Patio homes shall have a minimum 10-foot rear building setback.</p> <p>Townhomes shall have a minimum 5-foot rear building setback.</p> <p>Quads shall have a minimum 5-foot rear building setback.</p> <p>Alley product shall have a minimum 5-foot rear setback if front loaded and shall have a minimum 20-foot rear building setback if rear loaded.</p>	<p>Allowing reductions in minimum lot setbacks is necessary in order to achieve a variety of housing products which is an essential component of healthy and sustainable communities.</p>
Section 74.d.iii.1.1	<p>The perimeter boundary of a single-family residential development having single-family residential lots less than sixty-six hundred (6,600) square feet in area shall be located no closer than thirteen hundred and twenty (1,320) feet to the perimeter boundary of another single-family residential development having single-family residential lots less than sixty-six hundred (6,600) square feet in area. No Plan of Development area may contain more than five hundred (500) single-family residential lots with a lot area less than sixty-six hundred (6,600) square feet in lot area.</p>	<p>The Plan of Development area may contain more than five hundred (500) single-family residential lots with a lot area less than sixty-six hundred (6,600) square feet in lot area.</p>	<p>The Plan of Development area may contain more than five hundred (500) single-family residential lots with a lot area less than sixty-six hundred (6,600) square feet in lot area.</p>	<p>Allowing an increase in maximum lots will allow for a greater variety of housing products which is a necessary component in achieving a healthy and sustainable community. This will also allow for a greater ad valorem tax base.</p>

TABLE 8
Engineering Design Criteria Manual Variances

Design Manual Reference	Requirement	Proposed	Difference	Justification
Chapter 6.3.1.D	Minimum width requirements for a right-of-way: Local streets: 60 feet.	Minimum width requirements for a right-of-way: Local streets: 50 feet with a 10-foot utility easement on each side.	A reduction of 10 feet of ROW width, but an overall increase in area available for the street and utilities from 60 feet to 70 feet.	The pavement width would remain unchanged at 28 feet, so there is no impact on vehicular accessibility. The ROW reduction allows additional property to be on the tax rolls rather than in non-taxable ROW.
Chapter 6.3.1.E	Pavement width on local streets is 28' B-B for "low density" residential developments and 32' for "medium density" residential streets.	Paving width shall be 28' B-B for all residential streets.	Consistent paving width of 28' regardless of housing density.	Consistent paving width provides a predictable street design standard. Housing density in single-family residential neighborhoods is of a consistent character regardless of numerical density and does not affect street usage.
Chapter 6.3.1.J.m	Preferred cul-de-sac length of 600' or less; if exceeding 600' length the cul-de-sac increases to 45' paving radius in 50' ROW radius.	Maximum cul-de-sac length of 800' before wider paving radius is triggered.	Maximum length increased by 200'.	Standard suburban curvilinear street design is meant to encourage cul-de-sac designs, but the 600' length is arbitrarily short and limits the practical ability to provide culs-de-sac for the community.

Plan of Development

E. Interpretation

The City's Designated Official shall be responsible for interpreting the provisions of Plan of Development. Appeals to the Designated Official's interpretation may be made to City Council within thirty (30) days of the date of the interpretation.

F. Administrative Approval

Certain changes to the provisions may be made administratively by the City of Iowa Colony Designated Official, provided such changes are consistent with the intent and general purpose of the Plan of Development and do not result in the reduction of open space by more than ten (10) percent within the project or exceed the maximum number of dwelling units permitted.

Decisions by the Designated Official regarding administrative changes shall be subject to appeal by the City Council. The following categories shall be considered administrative changes, but are not limited to:

- The addition of new information to the Plan of Development, including maps or text that does not change or affect any of the regulations or guidelines contained therein. May include copies of the Developer's residential and commercial guidelines as applicable or any overall landscape plan and related tree/plant lists as may be developed through the course of this development, as well as any additional appendices that may be necessary to include and would not constitute a substantial change to the development as outlined below.
- Changes to the community infrastructure phasing and alignment, such as roads, drainage, water, and sewer systems.
- Changes of land uses shown in the Land Use Plan within the Plan of Development, division of areas or combinations of areas provided there is not a net loss of open space and no net increase in the total of units allowed. Updated versions of the Land Use Plan may be provided over the course of this project in order to show current progress or developed areas.
- Changes or modifications in lot sizes and/or configuration, provided that the lots meet the minimum requirements established in within this Plan of Development for their respective land use.
- Changes to development regulations that are in the interest of the community and do not affect health or safety issues.
- Placement and/or construction of community identity or character features such as entry monuments, neighborhood signage, community art, mailboxes, etc.
- Relocation or modification of school, park sites, trails, or any other community feature.
- The creation of gated neighborhoods, private residential streets, or other modifications in common area assets to be maintained by a group of residential homeowners, provided the overall circulation of the project is maintained.
- The determination that a use may be allowed which is not specifically listed as a permitted use but may be determined to be analogous and/or accessory to a permitted use as determined by the City's Designated Official.

Plan of Development

The City's Designated Official shall have the authority to make a determination whether an administrative approval is appropriate regarding any situations or circumstances that are not specifically listed here.

G. Substantial Change

The Plan of Development may be substantially amended by submitting a Plan of Development Amendment to the City of Iowa Colony. A modification shall be considered a substantial change if the open space is reduced by more than 10% or there is a net increase in the total of units allowed.

H. Fees

This Plan of Development will be the governing document for any future development ordinances passed that impact this Project. The developer acknowledges that the fee schedule may increase and will comply with increases in fees. All fees shall be fair and reasonable.

I. Sales Tax Sourcing

The Developers shall utilize, or cause its contractors to utilize, Separated Building Materials and Labor Contracts for all taxable building material contracts related to the Development in the amount of One Thousand Dollars (\$1,000.00) or more, to site payment of the sales tax on building materials for the Development to the Property.

J. Noncompliance

Noncompliance of the Plan of Development will result in withholding of building permits within the boundaries of the Plan of Development.

K. Expiration

The terms and regulations as outlined within this Plan of Development are intended to ensure adequate and predictable development regulations for the life of this project for the benefit of the City and the Developers. The terms of this Plan of Development shall constitute covenants running with the land comprising the Tract and shall be binding on all future developers and owners of any portion of the Tract, other than Ultimate Consumers. To that effect, this Plan of Development have an expiration date of fifteen years and will be the primary governing document for this property except as amended by necessity over the course of the project.