

RESOLUTION 22-05

A RESOLUTION AMENDING THE DESIGN STANDARDS AND CONSTRUCTION SPECIFICATIONS FOR PUBLIC WORKS CONSTRUCTION IN HYRUM CITY.

WHEREAS, the Hyrum City Council approved the revised Design Standards and Construction Specifications for Public Works Construction in Hyrum City in January 2003; and

WHEREAS, the Design Standards and Construction Specifications for Public Work Construction provides general requirements and design guidelines for installation of utilities and other public improvements in Hyrum City; and

WHEREAS, upon recommendation of Hyrum City's Engineer and Public Works Department, the City Council has determined there is a need to amend and update Hyrum City's Design Standards and Construction Specifications for Public Works Construction.

NOW, THEREFORE, BE IT RESOLVED by the City Council of Hyrum, Cache County, Utah, to approve the revisions, attached hereto as Exhibit "A", to Hyrum City's Design Standards and Construction Specifications for Public Works Construction in Hyrum

THIS RESOLUTION shall become effective upon adoption.

ADOPTED AND PASSED by the Hyrum City Council this 5<sup>th</sup> day of May, 2022.

HYRUM CITY CORP.

BY: \_\_\_\_\_  
Stephanie Miller  
Mayor

ATTEST:

\_\_\_\_\_  
Stephanie Fricke  
City Recorder

HYRUM CITY  
Power Department

SECTION 7

HYRUM CITY  
GENERAL REQUIREMENTS  
AND  
SPECIFICATIONS  
FOR  
ELECTRICAL INSTALLATIONS

## TABLE OF CONTENTS

---

7	GENERAL REQUIREMENTS AND SPECIFICATIONS FOR ELECTRICAL INSTALLATIONS.....	1
7.1	GENERAL REQUIREMENTS .....	1
7.1.1	GENERAL .....	1
7.1.2	COMPLIANCE AND CONFLICT WITH REQUIREMENTS .....	1
7.1.3	SERVICE DENIAL FOR UNSAFE CONDITIONS OR TAMPERING .....	1
7.1.4	UNDERGROUND UTILITY LOCATION -- CALL BEFORE YOU DIG .....	1
7.1.5	CUSTOMER GENERATION .....	1
7.1.6	GROUNDING AND BONDING .....	2
7.1.7	INSPECTION.....	2
7.1.8	POWER FACTOR .....	2
7.1.9	EQUIPMENT PERFORMANCE, PROTECTION, AND HARMONICS .....	2
7.2	PERMITS AND APPLICATIONS.....	3
7.2.1	SERVICE APPLICATION.....	3
7.2.2	PERMIT .....	3
7.2.3	EASEMENTS.....	3
7.3	SERVICES.....	4
7.3.1	TYPES OF SERVICE .....	4
7.3.2	STANDARD TRANSFORMER SIZES .....	4
7.4	METER REQUIREMENTS .....	5
7.4.1	GENERAL .....	5
7.4.2	METER BASE MOUNTING.....	5
7.4.3	METER LOCATION .....	5
7.4.4	DIRECT METERING .....	6
7.4.5	CURRENT TRANSFORMER METERING.....	6
7.4.6	SWITCHBOARD METERING (Above 800 amps).....	6
7.5	CLEARANCES.....	7
7.5.1	OVERHEAD SERVICES .....	7
7.5.2	UNDERGROUND SERVICES.....	7
7.5.3	BETWEEN EQUIPMENT PADS AND BUILDINGS.....	7

## SECTION 7 General Requirements and Specifications for Electrical Installations

---

7.6	UNDERGROUND REQUIREMENTS .....	7
7.6.1	SERVICE CONDUCTOR .....	8
7.6.2	SERVICE CONDUIT .....	8
7.6.3	BACKFILL.....	8
7.6.4	MARKING TAPE .....	8
7.6.5	JUNCTION BOXES .....	9
7.6.6	BOXPADS.....	9
7.6.7	TRANSFORMER PADS.....	9
7.6.8	CLEARANCES .....	9
7.6.9	GROUNDING METHODS.....	9
7.7	OVERHEAD SERVICE REQUIREMENTS .....	10
7.8	MULTI-FAMILY RESIDENTIAL BUILDINGS .....	11
7.8.1	GENERAL .....	11
7.8.2	MULTIPLE-METERS.....	11
7.9	COMMERCIAL, INDUSTRIAL, AGRICULTURAL SERVICES (ALL NON-RESIDENTIAL SERVICES) .....	12
7.9.1	GENERAL REQUIREMENTS .....	12
7.9.2	DIRECT-CONNECT METERING, SINGLE INSTALLATIONS .....	13
7.9.3	DIRECT-CONNECT METERING, MULTIPLE INSTALLATIONS.....	16
7.9.4	CT METERING, UP TO 800 A.....	17
7.9.5	SWITCHBOARD METERING, UP TO 4000 A .....	21
7.10	STREETLIGHTS.....	23
7.10.1	SUBDIVISION POLE-TOP LUMINARIES.....	23

---

**STEPS FOR UNDERGROUND/OVERHEAD SERVICE INSTALLATION AND HOOK-UP**

**Complete the following steps in the order listed below:**

1. Builder must fill out the Load Data Sheet, page 2 below, and return it to Hyrum City's Power Department. We use the sheet to document inspections and size the service wire/conduit. We will not perform the required trench inspections without a Load Data Sheet. The builder and Hyrum City Power will meet to determine if the service will be underground or overhead.
2. Do not begin work on the service installation before receiving the service design from Hyrum City's Power Department. Any work done that does not meet the Hyrum City Power Department design is at risk of having to be re-done at the cost of the builder/customer.
3. The building site requiring service must have its address marked and clearly visible from the street.
4. For underground service--Dig a trench (30" minimum depth) between the power source and meter equipment.  
For overhead service—Skip to step 7.
5. Install the conduit specified by Hyrum City Power (3"). At the power source, connect to the existing conduit stubbed from the transformer or secondary junction box. The meter riser must be aluminum and strapped to the foundation. Call Hyrum City (24 hours in advance) at 435-245-6033 to schedule a required inspection of the trench and conduit prior to backfilling.
6. After you have passed the conduit and trench inspection, cover the conduit with 4" of sand (to prevent the possibility of the conduit being damaged by backfilling with local soil), then 8" of soil. Approximately 1 foot directly above conduit, place red plastic electrical warning tape--3" wide over service, 6" wide over primary-- that reads, "Caution—Buried Electric Cable Below". Leave a tail of warning tape sticking out of the ground at the meter riser and power source. Backfill the trench to final grade.
7. Hyrum City will stick a U.G. Service Inspection Verification label to the inside of the meter base upon completion and inspection of the trench and conduit.
8. Contact Cache County for a power to panel inspection. When you pass the power to panel inspection . . .
9. At this point, you MUST have passed the building Dept. power to panel inspection.  
For underground service--Hyrum City will provide the wire for underground service. A Hyrum City crew will return to the building site and install the wire in the conduit, make the connections and set the meter.  
For overhead service--The customer will provide the wire from the weatherhead to the meter. Hyrum City will provide the wire for the overhead service from the source up to the weatherhead, make connections and set the meter.

HYRUM CITY ELECTRICAL DEPARTMENT  
RESIDENTIAL ELECTRIC POWER SERVICE REQUEST

**LOAD DATA SHEET**  
**SINGLE FAMILY RESIDENTIAL STRUCTURE**  
**Underground/Overhead Electric Service Feed**

**Architect/Engineer/Builder/Contractor:**

Please submit this form for each single-family residential structure to be served by Hyrum City Power by means of an underground or overhead service wire. Using the NEC code to size the service wire is acceptable. However, Hyrum City can potentially use the information submitted on this sheet to de-rate the wire size upon request. Also, this form is necessary for Hyrum City to track the required inspections. **Hyrum City will NOT perform any inspections without this form.** Submit the form by email: [Bballard@hyrumcity.com](mailto:Bballard@hyrumcity.com), by fax 435-245-4758, or by delivery to the address 60 West Main, Hyrum, UT. By signing this document, you are hereby acknowledging that the information provided is accurate and that you take responsibility for this information up to and including financial cost for the replacement of Hyrum City equipment due to any inaccuracies contained herein.

**Contractor Contact Information:**

Contractor/consultant name \_\_\_\_\_  
Contact person \_\_\_\_\_ Day phone # \_\_\_\_\_  
Cell phone # \_\_\_\_\_ Fax # \_\_\_\_\_ Best contact time  a.m.  p.m.  
E-mail address: \_\_\_\_\_

**Customer (Owner) Contact Information** *Complete this section if owner and contractor are separate individuals*

Name \_\_\_\_\_  
Mailing address \_\_\_\_\_ City, State Zip \_\_\_\_\_  
Day phone # \_\_\_\_\_ Cell phone # \_\_\_\_\_ Best contact time  a.m.  p.m.  
E-mail address: \_\_\_\_\_

**Service Information** *This section is required*

New service address \_\_\_\_\_ City, State Zip \_\_\_\_\_  
New service address coordinates (if applicable) \_\_\_\_\_

Subdivision name \_\_\_\_\_ Phase \_\_\_\_\_ Lot # \_\_\_\_\_ Block # \_\_\_\_\_  
If known, nearest pole or padmount # (pole/equipment tag, 10 or 12 digits) \_\_\_\_\_

Service panel size:  150 Amp  200 Amp  400 Amp Size of building: \_\_\_\_\_ total sq. ft.

Distance between service hookup (power source) and meter equipment: \_\_\_\_\_ ft.

Special conditions and/or requests \_\_\_\_\_

Main source of heat:  gas  propane  electric If electric:  heat pump (\_\_\_ tons)  furnace  
If air conditioning:  evaporative cooler  central air (\_\_\_ tons)  heat pump (\_\_\_ tons)  other

Would you like Hyrum City Electrical Department to determine the size of the underground service wire?  
 Yes  No

HYRUM CITY ELECTRICAL DEPARTMENT  
RESIDENTIAL ELECTRIC POWER SERVICE REQUEST

Expected building completion date *(mm/dd/yyyy)* \_\_\_\_\_

It is important to provide the most accurate information available as it is used to design the facilities to serve your requested load. You may want to consult a licensed electrician or engineer prior to providing the information. Changes to load after submitting this information may delay design and potentially impact cost.

Please sign and date this form

\_\_\_\_\_  
Applicant or representative signature

\_\_\_\_\_  
Date

**Please email or fax completed form to:** [Bballard@hyrumcity.com](mailto:Bballard@hyrumcity.com) , by fax 435-245-4758,  
or delivery to 60 West Main, Hyrum, UT.

---

**STEPS FOR UNDERGROUND/OVERHEAD SERVICE INSTALLATION AND HOOK-UP**

**Complete the following steps in the order listed below:**

1. Builder must fill out the Load Data Sheet, page 2 below, and return it to Hyrum City's Power Department. We use the sheet to document inspections and size the service wire/conduit. We will not perform the required trench inspections without a Load Data Sheet. The builder and Hyrum City Power will meet to determine if the service will be underground or overhead.
2. Do not begin work on the service installation before receiving the service design from Hyrum City's Power Department. Any work done that does not meet the Hyrum City Power Department design is at risk of having to be re-done at the cost of the builder/customer.
3. The building site requiring service must have its address marked and visible from the street.
4. For underground service--Dig a trench (30" minimum depth) between the power source and meter equipment.  
For overhead service—Skip to step 7.
5. Install the conduit specified by Hyrum City Power (4" minimum for 3 phase service) to the power source, connect to existing conduit. The meter riser must be aluminum and strapped to the foundation. Call Hyrum City (24 hours in advance) at 435-245-6033 to schedule a required inspection of the trench and conduit prior to backfilling.
6. After you have passed the conduit and trench inspection, cover the conduit with 4" of sand (to prevent the possibility of the conduit being damaged by backfilling with local soil), then 8" of soil. Approximately 1 foot directly above conduit, place red plastic electrical warning tape--3" wide over service, 6" wide over primary-- that reads, "Caution—Buried Electric Cable Below". Leave a tail of warning tape sticking out of the ground at the meter riser and power source. Backfill the trench to final grade.
7. Hyrum City will stick a U.G. Service Inspection Verification label to the inside of the meter base upon completion and inspection of the trench and conduit.
8. Contact Cache County for a power to panel inspection. When you pass the power to panel inspection . . .
9. At this point, you MUST have passed the building Dept. power to panel inspection.  
For underground service—The builder/customer shall install the wire in the conduit, make the connections in the transformer and meter/CT cabinet. Hyrum City will set the meter.  
  
For overhead service--The builder/customer will provide the wire from the weatherhead to the meter. Hyrum City will provide the wire for the overhead service from the source up to the weatherhead, make connections and set the meter.



HYRUM CITY ELECTRICAL DEPARTMENT  
COMMERCIAL ELECTRIC POWER SERVICE REQUEST

**LOAD DATA SHEET**  
**COMMERCIAL STRUCTURE**  
Underground/Overhead Electric Service Feed

**Architect/Engineer/Builder/Contractor:**

Please submit this form for each commercial structure to be served by Hyrum City Power by means of an underground or overhead service wire. Using the NEC code to size the service wire is acceptable. However, Hyrum City can potentially use the information submitted on this sheet to de-rate the wire size upon request. Also, this form is necessary for Hyrum City to track the required inspections. **Hyrum City will NOT perform any inspections without this form.** Submit the form by email: [Bballard@hyrumcity.com](mailto:Bballard@hyrumcity.com) , by fax 435-245-4758, or by delivery to the address 60 West Main, Hyrum, UT. By signing this document, you are hereby acknowledging that the information provided is accurate and that you take responsibility for this information up to and including financial cost for the replacement of Hyrum City equipment due to any inaccuracies contained herein.

**Contractor Contact Information:**

Contractor/consultant name \_\_\_\_\_  
Contact person \_\_\_\_\_ Day phone # \_\_\_\_\_  
Cell phone # \_\_\_\_\_ Fax # \_\_\_\_\_ Best contact time  a.m.  p.m.  
E-mail address: \_\_\_\_\_

**Customer (Owner) Contact Information** *Complete this section if owner and contractor are separate individuals*

Name \_\_\_\_\_  
Mailing address \_\_\_\_\_ City, State Zip \_\_\_\_\_  
Day phone # \_\_\_\_\_ Cell phone # \_\_\_\_\_ Best contact time  a.m.  p.m.  
E-mail address: \_\_\_\_\_

**Service Information** *This section is required*

New service address \_\_\_\_\_ City, State Zip \_\_\_\_\_  
New service address coordinates (if applicable) \_\_\_\_\_

Subdivision name \_\_\_\_\_ Phase \_\_\_\_\_ Lot # \_\_\_\_\_ Block # \_\_\_\_\_  
If known, nearest pole or padmount # (pole/equipment tag, 10 or 12 digits) \_\_\_\_\_

Service panel size: \_\_\_\_\_ amps      Size of building: \_\_\_\_\_ total sq. ft.

Load List			
Type	Description	Added Load	Units
HVAC/Refrigeration Equip.			Tons
Largest Motor (code: _____)			HP
Fans/small motors/pumps/compressors			HP
Electric Heating (space/water)			kW
Equipment with large power requirement			kW

HYRUM CITY ELECTRICAL DEPARTMENT  
COMMERCIAL ELECTRIC POWER SERVICE REQUEST

Distance between service hookup (power source) and meter equipment: \_\_\_\_\_ ft.

Special conditions and/or requests \_\_\_\_\_

Main source of heat:  *gas*  *propane*  *electric*      If electric:  *heat pump* (\_\_\_ tons)  *furnace*  
If air conditioning:  *evaporative cooler*  *central air* (\_\_\_ tons)  *heat pump* (\_\_\_ tons)  *other*

Would you like Hyrum City Electrical Department to determine the size of the underground service wire?  
 *Yes*    *No*

Expected building completion date (*mm/dd/yyyy*) \_\_\_\_\_

It is important to provide the most accurate information available as it is used to design the facilities to serve your requested load. You may want to consult a licensed electrician or engineer prior to providing the information. Changes to load after submitting this information may delay design and potentially impact cost.

Please sign and date this form

\_\_\_\_\_  
Applicant or representative signature

\_\_\_\_\_  
Date

**Please email or fax completed form to:** [Bballard@hyrumcity.com](mailto:Bballard@hyrumcity.com) , or by fax 435-245-4758,

or delivery to 60 West Main, Hyrum, UT.

## 7 GENERAL REQUIREMENTS AND SPECIFICATIONS FOR ELECTRICAL INSTALLATIONS

---

### 7.1 GENERAL REQUIREMENTS

#### 7.1.1 GENERAL

The purpose of this document is to assist Hyrum City Power customers in obtaining electric service. This document provides the requirements and shows the specifications for customer installations that must be met for electric service to be connected. It is the customer's responsibility to ensure compliance with these requirements and specifications. These requirements and specifications apply to new services, relocated services, house relocations, rewired services, and upgraded services.

Any work done before receiving the electric service design and signed contract from Hyrum City's Power Department that does not meet the Hyrum City Power Department design is at risk of having to be removed and re-installed at the cost of the builder/customer.

#### 7.1.2 COMPLIANCE AND CONFLICT WITH REQUIREMENTS

All electrical work shall be in compliance with the latest edition of the National Electric Code (NEC), International Building Code, ICC Electrical Code, and the National Electrical Safety Code (NESC) except where these specifications are more stringent. If there is a conflict between standards, the most stringent shall rule.

#### 7.1.3 SERVICE DENIAL FOR UNSAFE CONDITIONS OR TAMPERING

A service may be denied when unsafe conditions exist, or when the customer has tampered with utility-owned equipment, such as meters and lines. (Utah Administrative Code, Rule 746-200.) A residential service can be disconnected without notice when a clear emergency or serious safety hazard exists for so long as the conditions exist. The Power Department will immediately try to notify the customer of the disconnection and the reasons for it.

#### 7.1.4 UNDERGROUND UTILITY LOCATION -- CALL BEFORE YOU DIG

State law requires the customer/excavator to call 8-1-1 to mark underground utility locations at least 48 hours prior to any excavation. Do not start excavation until utilities have been marked by an underground locator service, or until the service confirms that no utilities exist in the area.

#### 7.1.5 CUSTOMER GENERATION

Interconnection of customer distributed generation will be evaluated on a case-by-case basis. Contact Hyrum City Power before acquiring generation equipment or making any type of interconnection with any type of generating device to determine the requirements that must be met.

#### 7.1.6 GROUNDING AND BONDING

The customer is responsible for ensuring that electrical wiring and service equipment are grounded and bonded in accordance with applicable NEC requirements. The grounding system shall have sufficient grounding electrodes, effectively bonded together, to prevent maximum resistance to ground exceeding 25 ohms. All grounding is to be in accordance with NEC Article 250.

Two ground rods 5/8" diameter x 8' long shall be driven at each three-phase transformer and three phase junction point, at 5' center to center (spacing). One ground rod shall be driven at each single-phase transformer and single-phase primary junction point. All concentric neutrals shall be connected and commonly grounded to the driven ground rod.

In cases where ground rods cannot be installed at transformers, primary junction boxes and switches due to very rocky soil, 100 ft. of bare #2 copper-clad wire can be buried at least 18" deep in place of the ground rod(s). See requirements in Section 7.6.9.

Metallic equipment less than 6 feet from Hyrum City Power equipment requires bonding to the Hyrum City Power equipment.

#### 7.1.7 INSPECTION

All work shall be inspected and approved by the City's Power Department personnel before underground systems are backfilled. Cache County will perform "power to the panel" inspections. Final inspection and energizing the system will be performed by the City's Power Department personnel.

#### 7.1.8 POWER FACTOR

The customer is responsible for maintaining power factor between 95% lagging and 95% leading, or higher. Hyrum City Power recommends that customers provide and maintain code-approved power factor correction devices to maintain power factor between 95% lagging and 95% leading.

A power factor rate adjustment applies to customers with three-phase service and loads that exceed 200 kilowatts for three (3) consecutive months. This rate adjustment has the effect of increasing the power demand charges to customers who do not maintain a power factor of 95% or higher.

#### 7.1.9 EQUIPMENT PERFORMANCE, PROTECTION, AND HARMONICS

The customer shall provide any power-conditioning devices necessary for the proper performance and protection of voltage-sensitive equipment. The customer is responsible for providing and maintaining code-approved protective devices to protect equipment against overloading, short circuits, ground faults, high or low voltage, and single-phasing of three-phase motors.

Customers shall not generate harmonic distortion that create disturbances on the electrical system that interfere with any other customer's equipment. Customers shall provide harmonic filtering on equipment that can produce harmonic distortion (such as adjustable speed drives, power supplies, and electronic ballasts for lighting) such that harmonic distortion is kept within the limits specified in IEEE Standard 519, Section 10. The customer shall take necessary action, at the customer's sole expense, for the customer's facility to stay within these limits. Failure to operate within these limits can result in termination of electrical service or other remedial action as provided by state regulatory authority (Utah Administrative Code, Rule 746-310-2-D, "Conditions of Service"). Compliance with this requirement is judged by the City's Power Department personnel's measurement at the service point.

## 7.2 PERMITS AND APPLICATIONS

### 7.2.1 SERVICE APPLICATION

The customer shall complete an Electric Power Service Request Load Data Sheet to apply for electric service. The customer shall provide accurate load information on the request. The steps for service installation and hook-up are detailed on this request form. Refer to the request forms "Residential Electric Power Service Request" or "Commercial Electric Power Service Request" at the front of this standard.

### 7.2.2 PERMIT

City ordinances require applicants to obtain appropriate permits as per Hyrum City code before electric service is provided.

### 7.2.3 EASEMENTS

The customer (developer) shall provide, without cost to Hyrum City, all permits, rights-of-way, and easements required for the installation and maintenance of the public facilities that serve the customer (development). A Public Utility Easement (PUE) will be required in all subdivisions adjacent to the road right-of-way. A ten (10) foot easement is required along all frontages and may be required at rear and side lot lines at the discretion of City staff. If a PUE is required along the rear or the side of lots, the total width may be evenly split between the adjoining lots. No permanent structure or obstruction can be placed within the PUE without prior written approval of all Hyrum City owned utilities.

## 7.3 SERVICES

### 7.3.1 TYPES OF SERVICE

Electric service is provided as 60-hertz, alternating current, single-phase or three-phase. Nominal provided secondary voltages and types of service are shown in Table 1.

*Table 1-Type and Voltage of Secondary Service*

Phases	Voltage	Wiring	Limits
Single-phase	120 volts	Two-wire, grounded	200 amps or less
Single-phase	120/240 volts	Three-wire, grounded	400 amps or less
Three-phase	120/208 volts	Four-wire, grounded wye	750 kVA or less
Three-phase	277/480 volts	Four-wire, grounded wye	n/a

Contact Hyrum City Power to determine the requirements that must be met for primary voltage service at 7,200/12,470 volts.

### 7.3.2 STANDARD TRANSFORMER SIZES

Standard transformer sizes that are allowed are given in Table 2.

*Table 2-Standard Transformer Sizes*

Overhead Transformers	Secondary Voltage	Sizes in kVA
Single-phase	120/240 volts	25, 50, 75, 100, 167
Three-phase (bank of 3 single-phase transformers)	120/208 volts	75, 150, 225, 300
	277/480 volts	75, 150, 225, 300
Pad-mounted Transformers		
Single-phase	120/240 volts	25, 37.5, 50, 75, 100
Three-phase	120/208 volts	75, 150, 225, 300, 500, 750
	277/480 volts	75, 150, 225, 300, 500, 750, 1000, 1500, 2500

## 7.4 METER REQUIREMENTS

### 7.4.1 GENERAL

1. The customer is responsible for providing, installing, and maintaining all service equipment.
2. Meters shall be located where approved by Hyrum City Power.
3. Meters shall be accessible at all times for reading, maintenance, and emergencies.
4. Meters located within a gated area or enclosed space shall be approved prior to installation on a case-by-case basis.
5. Customers must contact Hyrum City Power before doing any work that involves the meter.
6. Meter bases shall be from Hyrum City Power Department's approved list.
7. The minimum size meter base is 150 amps.
8. Three-phase 200 amp meter bases shall have a lever by-pass.

### 7.4.2 METER BASE MOUNTING

1. Meter bases must be mounted to be plumb in all directions and securely mounted to a rigid surface.
2. Prior approval is required for installing meters in any type of enclosure.
3. Adequate protection for meters subject to physical damage must be provided.

### 7.4.3 METER LOCATION

The customer must provide a suitable meter location, with adequate clear working space. Metering equipment **shall not be installed** in the following locations unless prior approval is obtained from Hyrum City Power:

1. Any unsafe location, as determined by Hyrum City Power
2. Any hazardous location for electrical equipment as defined by the NEC
3. Within a 36 inches radius of the gas meter, gas valves, regulators, fittings, unions, or the gas line entrance into a building.
4. Directly over any window well, stairway, ramp or steps
5. In any entryway
6. Within 36 inches horizontally of a window that has a view of a living space or restrooms, or within 36 inches horizontally of a door.
7. In any place where moisture, fumes, or dust may interfere with the meter's operation or may damage the meter, as determined by Hyrum City Power
8. On any surface subject to excessive vibration, as determined by Hyrum City Power
9. In an area where metering is likely to be fenced in
10. Where the metering equipment is obstructed by anything including landscaping or other vegetation
11. Areas adjacent to fuel storage units

Residential meters shall be installed:

1. Outdoors within 10 feet of the front (street side) corner of the dwelling
2. On the side of the dwelling closest to the power source
3. At a location acceptable to Hyrum City Power, and in accordance with the standards drawings in this document.

Where there is no suitable location on the structure, a free-standing metering installation may be used, at a location approved in advance by Hyrum City Power.

#### 7.4.4 DIRECT METERING

Direct-connect metering is required for residential services, and for single-phase services 400 amps or less, or three-phase services 200 amps or less. There are additional requirements for direct-connect metering installations with more than one meter.

See sections 7.9.2 and 7.9.3 for requirements for non-residential direct metering installations.

#### 7.4.5 CURRENT TRANSFORMER METERING

Current transformer (CT) metering is required for single-phase services greater than 400 amps and three-phase services greater than 200 amps. Hyrum City Power will provide and install: the meter, a meter test switch, CTs, and secondary metering wiring. Hyrum City Power will provide the CT cabinet and CT mounting base, paid for by the customer. The customer shall provide conduit, connectors/terminations, a disconnect after the CT cabinet rated for the load, and bonding for meter and CT enclosures. The customer shall make connections of service wire in the CT cabinet.

See section 7.9.4 for detailed CT metering installation requirements.

#### 7.4.6 SWITCHBOARD METERING (Above 800 amps)

Switchboard metering is required for services greater than 800 amps. The customer shall provide a drawing of the proposed switchboard metering equipment and a mounting pad with dimensions, to Hyrum City Power for review and approval. Approval must be obtained prior to fabrication.

The customer shall provide and install:

- a. Switchboard enclosure with CT compartment
- b. Meter base
- c. Metering conduit—one-inch (1") minimum electrical non-metallic tubing (ENT) or flexible PVC for the metering secondary conductors
- d. Locking equipment for the meter enclosure
- e. Concrete mounting pad for the switchboard enclosure



- f. A flat permanent surface (such as a concrete pad) extending a minimum of 36 inches (36") out from the switchboard in front of the CT compartment

See section 7.9.5 for the requirements for switchboard metered installations.

## 7.5 CLEARANCES

### 7.5.1 OVERHEAD SERVICES

The customer shall provide a point of attachment for overhead service that allows minimum clearances listed in the NESC for service drops and drip loops to be met in all conditions. Contact Hyrum City Power if the service length may be greater than 45', or the service will cross over uneven or sloped ground that may impact clearance height.

The lowest point of the overhead service cable and drip loop shall be at least 18" above the roof. No more than 72" of the service cable can run across the roof of the structure being served. Refer to the overhead service standard drawings in this document.

### 7.5.2 UNDERGROUND SERVICES

Clear workspace and fire code clearances must be maintained around pad-mounted equipment for underground services. Refer to the underground service standard drawings in this document.

At least 3 feet clear workspace measured from the edge of the equipment pad shall be available on the non-access side of pad mounted equipment.

At least 10' clear workspace measured from the edge of the equipment pad shall be available on the access (working) side of pad mounted equipment.

### 7.5.3 BETWEEN EQUIPMENT PADS AND BUILDINGS

The front of the equipment pad should always face away from adjacent structures and be free of obstructions. At least 8 feet, must separate the edges of the pad from any adjacent structure. The edges of the pad must be at least 10 feet from any combustible structures.

## 7.6 UNDERGROUND REQUIREMENTS

All underground service shall be installed in conduit. The customer shall provide conduit in place from the point of connection to the meter base. For residential service Hyrum City Power will pull the secondary service wire. For commercial service the customer shall provide and pull the secondary service wire.

The customer shall be sure that conduit is located where it will not be next to (or underneath) buildings, building foundations, or other structures (including retaining walls.)

The customer shall install six 3-inch conduits at road crossings where there is primary voltage crossing. Where there is secondary conductor that will cross a road the customer shall install three 3-inch conduits.

Hyrum City Power will allow only one overhead-to-underground conduit (or underground-to-overhead conduit—a “riser” or “dip”) on an overhead power distribution pole, whether it is primary voltage or secondary.

#### 7.6.1 SERVICE CONDUCTOR

For residential service Hyrum City will provide the wire for underground service.

For commercial service the builder/customer must provide the wire for underground service. Cable shall be tri-plexed aluminum “EC”. Individual conductors shall be covered with XLP insulation rated to 600 volts and shall have color coded jacket. The color-coded service cable shall extend from the transformer to the main service breaker.

#### 7.6.2 SERVICE CONDUIT

The customer shall provide and install the conduit. All conduit in the ground shall be not less than Schedule 40 PVC electrical grade (gray with red stripe) conduit, 3-inches in diameter or larger, depending on the cable size and distance. Any conduit above ground shall be aluminum. For commercial three-phase service the minimum conduit size is 4-inches, or greater according to the wire and secondary service size.

#### 7.6.3 BACKFILL

Trench and conduit shall be inspected by Hyrum City Power prior to backfilling. All conduit shall be embedded in sand. The sand shall extend a minimum of 2 inches below and 4 inches above the conduit to prevent the possibility of the conduit being damaged by backfilling with local soil. Backfill material shall be compacted. Install marking tape as required in section 7.6.4.

In areas of the trench where there is no equipment, no paving, or other structural requirement, the local soil may be used as backfill as long as it has no cobbles, construction waste or other refuse or deleterious materials.

A minimum of 30” of backfill above underground secondary/service conduit is required.

Excavated areas that support electrical equipment (transformers, junction boxes, switchgear, etc.), pavement, walks, etc., shall be backfilled with compacted sand. Backfill shall be compacted in lifts no more than 2 feet. The final compaction beneath areas supporting electrical equipment shall be 95% of the maximum dry density as determined by ASHTO T-99.

#### 7.6.4 MARKING TAPE

Marking Tape shall be installed 12” above all buried conduits. It shall be red in color, 3” – 6” wide and state, “Caution—Buried Electric Cable Below”

#### 7.6.5 JUNCTION BOXES

Primary and secondary junction boxes shall be placed on well compacted and level ground, meeting the backfill requirements in Section 7.6.3 and also placed so as to avoid being filled with drainage water. The secondary junction box shall be an upright pedestal type, Pencil-AG-20-HDX or approved equal.

#### 7.6.6 BOXPADS

Box pads shall be placed on compacted and level ground meeting the backfill requirements in Section 7.6.3.

#### 7.6.7 TRANSFORMER PADS

The transformer pads for transformers less than 100 kVA shall be Nordic single-phase box pad #CBP-37-43-15A (with cable openings 12" x 24") or approved equal. The top of the transformer pad shall be at least 2 inches above the sidewalk. Concrete pads must meet the following requirements and shall be approved by Hyrum City Power:

##### *7.6.7.1 Site Preparation*

All dirt beneath the pad site must be compacted meeting the backfill requirements in Section 7.6.3, and level prior to setting or pouring the pad to prevent settling.

##### *7.6.7.2 Concrete*

Concrete shall be made using 6 bags of standard brand of Portland cement per cubic yard. Steel reinforcement shall be No. 4 bars placed on 12" centers and in accordance with the concrete transformer pad drawing. The pad must be poured at least three full days prior to setting the transformer. Concrete shall be kept above freezing at least 72 hours after pouring. The finished surface must be completely flat and level.

##### *7.6.7.3 Conduit Window Layout*

Low voltage conduits shall be formed as tightly as possible against the right side of the opening and shall in no case extend further than 20" from the right side of the conduit window on a small pad (96" x 78") or 30" on a large pad (100" x 103"). Do not put any concrete in or under the conduit window. Use dirt to separate conduits. All construction shall be in accordance with the latest International Electric Code and approved by Hyrum City Power.

#### 7.6.8 CLEARANCES

The front of the pad should always face away from adjacent structures and be free of obstructions. At least 8 feet must separate the edges of the pad from any adjacent structure. The edges of the pad must be at least 10 feet from any combustible structures.

#### 7.6.9 GROUNDING METHODS

Driven ground rods are required at services, transformers, primary junction boxes and switches. In cases where ground rods cannot be installed at transformers, primary junction boxes and

switches due to very rocky soil, 100 ft. of bare #2 copper-clad wire can be buried at least 18” deep in place of the ground rod. At least 100 total feet of wire, laid approximately straight, is required. Wire may be installed in a single length or several connected lengths, such as in a grid pattern.

### 7.7 OVERHEAD SERVICE REQUIREMENTS

Hyrum City Power provides all service wire to the meter mast (weatherhead) on overhead connections.

All residential overhead services shall be sized in accordance with Table 3. The minimum residential service permitted shall be a 150-amp service. Customers shall provide all service secondary conductor from the point of connection (weatherhead) to the meter base on overhead services.

*Table 3-Residential Secondary Conductor Size—Customer Overhead Service Wire from Weatherhead to Meter*

Square Footage of Residence	Service Size	Secondary Conductor Size	Neutral Conductor Size
Under 1200 s.f.	150 amp	1/0 Aluminum	#2 AWAC
1200 s.f. & above	200 amp	4/0 Aluminum	2/0 AWAC

The customer shall provide a point of attachment for overhead service that allows minimum clearances to be met in all conditions. Contact Hyrum City Power if the service length may be greater than 45’, or the service will cross over uneven or sloped ground that may impact clearance height.

Mast shall be 2” or 3” rigid conduit, depending on the size of the service (see Table 4). The meter mast shall be securely connected to the structure with at least 2 points of attachment using Unistrut and 3/8” minimum lags.

*Table 4-Meter Mast Conduit Size*

Service Size	Conduit Size for Meter Mast
200 amp or less	2” min.
201 – 400 amp	3” min.
Above 400 amp	Contact Hyrum City Power

Mast weatherhead shall pass through the building eave and extend at least 24” above the roof, unless the weatherhead is mounted on the gable end of the building. The lowest point of the

overhead service cable and drip loop shall be at least 18" above the roof. No more than 72" of the service cable can run across the roof of the structure being served.

If the point of attachment is more than 36" above a point of support on the mast, two independent guys are required.

## 7.8 MULTI-FAMILY RESIDENTIAL BUILDINGS

### 7.8.1 GENERAL

This section describes services with separate meters for multi-family residential buildings with three or more units. Hyrum City Power requires grouping of service entrance conductors at a common location.

Requirements:

1. All meters shall be in a common location.
2. Meter banks shall be installed on the side of the building closest to the power source.
3. The service entrance and meter shall be installed in locations meeting the requirements of Section 7.4.
4. The service entrance shall be sealed.

### 7.8.2 MULTIPLE-METERS

All multiple meter installations shall meet the following requirements.

Requirements:

1. Meter bases shall not be used as junction boxes.
2. Meter bases shall be selected from the Hyrum City Power Department list of acceptable meter bases.
3. A main disconnect is required when more than six services are connected. If an existing installation expands beyond six services, a main disconnect shall be installed.
4. NEC-approved load calculations are required when the sum of distribution section ampacities exceeds the pulling section ampacities. (See NEC Article 220, Branch-Circuit, Feeder, and Service Calculations.)
5. The cable pulling section must be appropriately sized for service termination.
6. Each service shall have a lockable and easily accessible disconnect in sight of the meter base location. If the disconnect is not in sight of the meter base, a label shall be placed at the meter base location indicating the location of the disconnect.
7. All required labels shall be correctly installed before the service is energized. Labels shall:
  - a. be permanently affixed to the equipment
  - b. be of sufficient durability to withstand the local environment. Engraved metal or hard plastic labels are required.

- c. not be attached to removeable covers
- 8. Each metered service and associated breaker shall be labeled to identify the dwelling unit address. Service will not be connected until permanent labels are attached.
- 9. It is the responsibility of the customer to ensure the meter bases are correctly labeled. These labels shall be kept current for the life of the facility.
- 10. A minimum vertical clearance of at least 66" from the center of the lowest meter to the final grade is required. However, a minimum vertical clearance of 36" to the center of the lowest meter is acceptable if a minimum 36" wide, flat, permanent surface (such as a concrete pad or walkway) below the meter is provided at the final grade and extends at least 18" on either side of the meter cabinet.
- 11. All unused openings shall be covered and secured by the customer.
- 12. Meters and metering equipment shall be located outdoors.
- 13. Panel covers must be secured in place prior to service equipment being energized.

## 7.9 COMMERCIAL, INDUSTRIAL, AGRICULTURAL SERVICES (ALL NON-RESIDENTIAL SERVICES)

This section provides the Hyrum City Power requirements for non-residential services. These services may be single-phase or three-phase, direct-connect or current transformer (CT) metered. Single-phase service up to 400 amps (A) and three-phase services up to 200 A can use direct-connect metering. CT metering equipment is required for single-phase service greater than 400 A and three-phase services greater than 200 A.

Non-residential customers should be sure to communicate with Hyrum City Power before purchasing and installing equipment.

The "General Requirements" in section 7.9.1 apply to all single-phase, three-phase, direct-connect, and CT metered commercial, industrial, and agricultural services. The subsequent sections provide additional requirements for direct-connect metering and CT metering, including multiple direct-connect meters, combination direct-connect and CT metering, and CT metering using switchboard (switchgear) equipment.

### 7.9.1 GENERAL REQUIREMENTS

- 1. All meter base enclosures shall be ring-type.
- 2. Acceptable meter bases are those manufactured in accordance with current EUSERC, ANSI-C12, and UL/ANS 1-414 requirements.
- 3. A main disconnect is required when more than six services are connected. If an existing installation expands beyond six services, a main disconnect shall be installed.
- 4. NEC-approved load calculations are required when the sum of distribution section ampacities exceeds the pulling section ampacities. (See NEC Article 220, Branch-Circuit, Feeder, and Service Calculations.)

5. Each service shall have a lockable and easily accessible disconnect in sight of the meter base location. If the disconnect is not in sight of the meter base, a label shall be placed at the meter base location indicating the location of the disconnect.
6. All required labels shall be correctly installed before the service is energized. Labels shall:
  - a. be permanently affixed to the equipment
  - b. be of sufficient durability to withstand the local environment. Engraved metal or hard plastic labels are required.
  - c. not be attached to removeable covers.
  - d. be kept current for the life of the facility.
7. Each metered service and associated breaker shall be labeled to identify the unit address. Service will not be connected until permanent labels are attached.
8. A minimum vertical clearance of at least 48 inches (48") from the center of the lowest meter to the final grade is required. However, in installations of three or more ganged meters, a minimum vertical clearance of 36 inches (36") to the center of the lowest meter is acceptable if a minimum 36 inches (36") wide, flat, permanent surface (such as a concrete pad or walkway) below the meter is provided at the final grade and extends at least 18 inches (18") on either side of the meter cabinet.
9. On overhead services, the customer must furnish all lugs and connect conductors to the line- side terminals. The customer is responsible for bringing the service entrance conductor to the connection of the utility service drop.
10. Cable termination connectors should have two bolts per connector. When mechanical lugs are used, two setscrews per conductor should be used where feasible.
11. All unused openings shall be covered and secured by the customer.
12. Meters and metering equipment shall be located outdoors.

#### 7.9.2 DIRECT-CONNECT METERING, SINGLE INSTALLATIONS

The required types of direct-connect meter bases for commercial, industrial, and agricultural services are listed in Table 5. Typical direct connect meter bases and typical service connections are illustrated in the figures in this section.

Direct-connect meter bases serving continuous duty motors are limited to 60 hp or less at 120 V/ 208 Y or 120 V/240 V, three-phase, and 125 hp or less at 277 V/480 Y, three-phase.

Three-phase 200-amp meter bases shall have a lever by-pass

SECTION 7 General Requirements and Specifications for Electrical Installations

Table 5. Direct-connect Meter Base Requirements

Direct-connect Service Type	Amperage	Meter Base Requirement	Figure
Single-phase	200 A max.	EUSERC 305	Figure 1
Single-phase, Overhead Only	201-400 A	EUSERC 302B	Figure 3
Single-phase, Overhead and Underground	201-400 A	na	Figure 3
Network	200 A max.	EUSERC 305	
Three-phase	200 A max.	Lever By-Pass	Figure 2

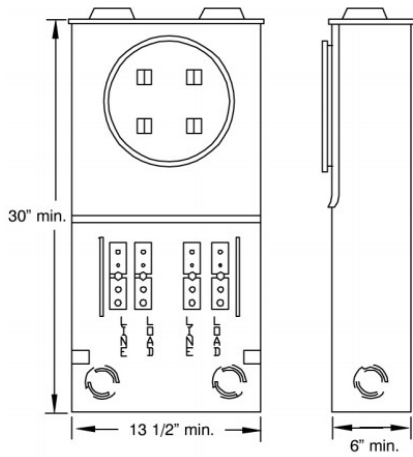

Figure 1 EUSERC 305 Single Phase



Figure 2 200-A Three-phase with Lever By-Pass

**400 Amp Max**



Figure 3 EUSERC 302B



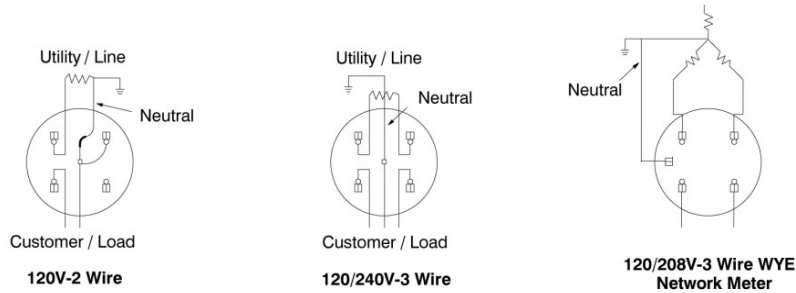

Figure 4 Typical Single-phase Service Connections (Meter Base Front View)

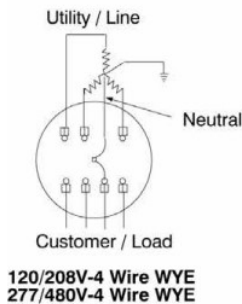

Figure 5 Typical Three-phase Service Connection (Meter Base Front View)

### 7.9.2.1 UNDERGROUND SERVICE METER PEDESTALS

Service meter pedestals meeting EUSERC 308 requirements can be used for non-residential underground service installations.

### 7.9.2.2 FREE-STANDING SERVICE METER INSTALLATIONS

Free-standing installations may be used for non-residential underground service or overhead service.

#### 7.9.2.2.1 Underground Service

The installation requirements for direct connection, underground service, free-standing meters are listed below. These requirements are in addition to the general requirements in this section.

Requirements:

1. The customer shall consult Hyrum City Power to determine the location of the freestanding meter base.
2. The free-standing meter base shall meet all local ordinance requirements.
3. The meter base shall be protected from damage by use of barrier posts or other suitable protection approved by Hyrum City Power.

4. The customer shall furnish, install and maintain approved steel or wood post(s). If a wood post is used, it shall be no less than 6"x 6" (nominal) and pressure-treated with an American Wood Preservative Association approved preservative.

The typical meter installations for a free-standing installation using steel posts is shown on drawing A.11

#### 7.9.2.2.2 Overhead Service

Free-standing installations may be used for non-residential overhead service. The installation requirements for direct connection, overhead service, free-standing meters are listed below. These requirements are in addition to the general requirements in this section.

Requirements:

1. Wood poles shall be of sound timber. The pole or timber must be free of any defects that may weaken the wood, such as sucker knots and spike knots larger than 1/2 of any face. Cracks greater than 1/2 -inch wide are not permitted. No visible wood decay is allowed.
2. The pole height must provide required clearance for the Hyrum City Power's service drop and any other attachments. The customer shall install the meter base and service equipment on a wood pole no less than 25 feet long and 5-1/2 inches in diameter at the top, or a (nominal) 6"x 6" x 25' timber, set no less than 60 inches below ground level, with suitable backfill. The pole or timber shall be pressure- or thermally- treated with an approved preservative.
3. The pole or timber shall be easily accessible by Hyrum City Power power-lift aerial equipment.
4. In unstable soil, conductor lengths in Table 18 may be reduced; guying or bracing shall be required.
5. The conductor must be at least 24 inches (24") in length outside the weatherhead.

#### 7.9.3 DIRECT-CONNECT METERING, MULTIPLE INSTALLATIONS

This section lists the requirements in addition to the general requirements for direct-connect, non-residential, single-phase and three-phase installations with more than one metered service.

Before being energized, the meter base shall be properly wired and grounded, and all necessary permits shall be in place. Ganged, modular, and switchboard styles of metering base equipment are approved for use.

Consult with Hyrum City Power regarding the design of the multiple metering services before purchasing and installing equipment.

---

Requirements:

1. Metering conductors shall not pass through adjacent metering compartments except in enclosed wireways.
2. A test bypass facility (TBF) with rigid insulating barriers shall be furnished, installed, and wired or bussed to the meter bases. TBF cover panels shall be sealable and fitted with a lifting handle.
3. A pull box section is required for two or more services and must meet EUSERC 343 and 343A requirements for the type and size of service. In addition:
  - a. Only Hyrum City Power conductors are allowed inside the pull box;
  - b. The pull box shall be sealable, and will be sealed by Hyrum City Power;
  - c. Customer-owned devices shall not be installed in the pull box;
  - d. No taps are allowed inside the pull box; and,
  - e. The customer shall not terminate their grounding electrode conductor in the pull box or use the pull box as a junction point for the grounding or to ground the electrode conductors.
4. For ganged meters, where the face of a cabinet exceeds the depth of the adjacent meter cabinet, clearances shall be in accordance with NEC.
5. For switchboard metering installations, the customer must provide a concrete pad for switchboard metering service sections and pull boxes.

**7.9.4 CT METERING, UP TO 800 A**

This section lists the requirements for CT metered services rated up to 480 V and 800 A.

Table 6 identifies customer-provided material for CT metering. Hyrum City Power will provide and install the meter, a meter test switch, current transformers, and secondary metering wiring. Hyrum City Power will provide the CT cabinet and CT mounting base, paid for by the customer.

The customer shall make connections of service wire in the CT cabinet.

*Table 6 Customer Provided Material for CT-Metering*

<b>Customer Provides</b>	<b>See for More Information</b>	<b>Requirements/Application Notes</b>
Conduit	Section 7.9.4.3	The conduit between the meter base enclosure and the CT cabinet, see Section 7.9.4.3.
Connectors/Terminators		Connectors for the load-side conductors to CT mounting base, as well as overhead service.

SECTION 7 General Requirements and Specifications for Electrical Installations

Customer Provides	See for More Information	Requirements/Application Notes
Disconnect		Downstream of CT cabinet rated for the load
Bonding	Section 7.9.4.4	Bonding per Section 7.9.4.4 for all meter and CT enclosures.

**7.9.4.1 CT CABINET**

The CT cabinet consists of two parts: the enclosure and the mounting base for the current transformers. The cabinet is exclusively for Hyrum City Power metering equipment.

**Requirements:**

1. Only equipment associated with Hyrum City Power metering shall be permitted in the CT cabinet.
2. The door shall have factory-installed hinges for side opening and shall be sealable.
3. The door shall be equipped with a device to hold it in the open position at 90° or more.
4. The top of the CT mounting base shall not be more than 72 inches (72") above the finished grade.
5. The customer’s service entrance conduits must exit the cabinet on the load side of the CT.
6. Customer conductors are not permitted in the Hyrum City Power termination space.
7. The customer shall not terminate their principal (main) grounding electrode conductor in the CT cabinet or use it as a junction point for grounding or grounding electrode conductors.
8. For multiple metered circuits, a separate termination pull box must be provided for the Hyrum City Power service lateral. The CT cabinet shall not be used as a load distribution center.

*Table 7 CT Cabinet Requirements*

Type of Service	EUSERC # for CT Cabinets	Minimum Cabinet Dimensions			EUSERC # for CT Mounting Base
		Width	Height	Depth	
Single-phase, 401-800 A	316, 317	24"	48"	11"	328A
Three-phase, 201-800 A	316, 318	36"	48"	11"	329A

**Notes:**

1. Where both line and load conductors enter or exit from the top or bottom of the cabinet a larger cabinet is required.
  - a. The dimension of the cabinet shall be 48"W x 48"H x 14"D. (These dimensions are greater than EUSERC316 and 318 minimums.)
  - b. The cabinet shall have two sealable, hinged doors with handles.
2. The door shall have factory-installed hinges for side opening and shall be sealable.

**Meter Base Location:**

1. For single-hinged CT cabinets the meter base shall be located opposite the hinged side, and not above or below the cabinet.
2. For dual-hinged CT cabinets, the meter base can be mounted on either side of the cabinet but not above or below it.

**7.9.4.2 CT MOUNTING BASE AND CABLE TERMINATION**

CT mounting bases are provided by Hyrum City Power, paid for by the customer.

**Requirements:**

1. The CT mounting base shall meet the ratings for the available fault current at the location installed (50,000 A minimum).
2. For existing four-wire delta services, the high (power) leg conductor must be identified by orange marking and located on the right-hand bus position. The bus shall also be marked and readily identified.
3. The mounting base shall accept bar-type current transformers only.
4. No alteration of the mounting base is allowed.
5. Line and load-side cable terminations on EUSERC 328A or 329A CT landing pads require two bolts per connector.
6. Cable termination can only be made on the manufacturer-supplied studs of the transformer mounting base.

**7.9.4.3 CT METERING CONDUIT**

The customer must provide conduit between the meter base and the CT cabinet. When installing conduit, the following requirements shall be met:

**Requirements for a meter within 12" of a CT cabinet:**

1. Conduit shall be one-inch (1") IMC, Schedule 40 PVC, or greater.

2. Proper fittings and bushings shall protect metering conductors.

**Requirements for a meter greater than 12" and up to 50' from the CT cabinet:**

1. The meter base must be visible from the CT cabinet.
2. Conduit runs must be less than 50 feet (50').
3. Conduit shall be 1-1/4 " IMC or greater.
4. Conduit runs may not have more than three bends totaling 270°. No single bend greater than 90° is allowed.
5. Removable conduit fittings shall have sealing provisions.
6. LB connectors are not allowed between the CT cabinet and the meter base.

**7.9.4.4 CT CABINET BONDING**

The CT cabinet must be properly bonded and grounded per the NEC. Figure 6 illustrates one acceptable solution.

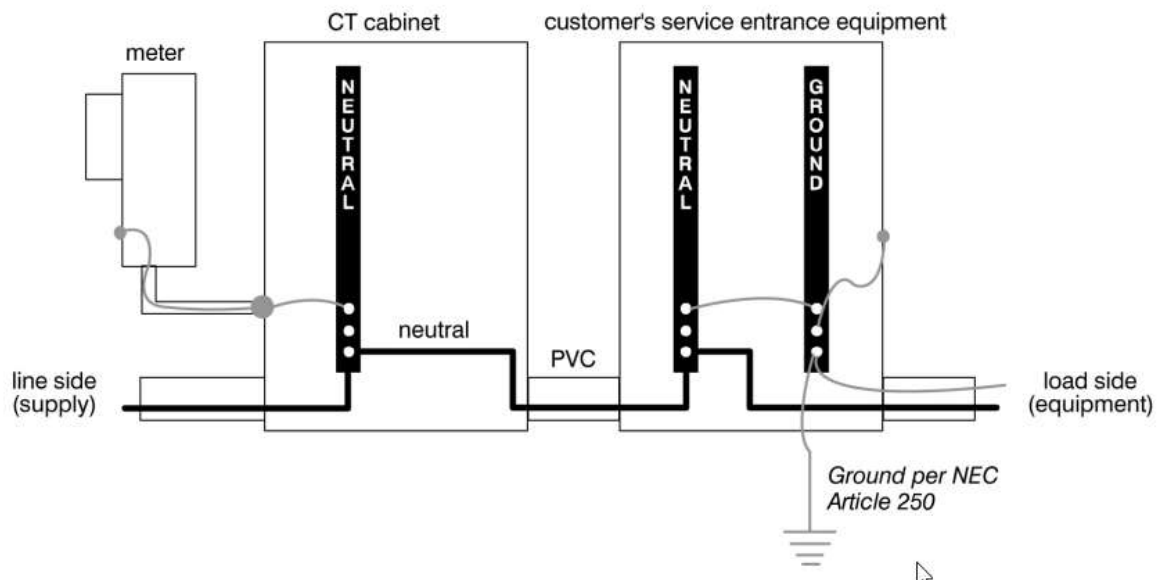

Figure 6 CT Cabinet Bonding, Example

**7.9.4.5 CT METERING, FREE STANDING**

This section lists the requirements in addition to the general requirements in this section for of free-standing CT metering installations on posts. Free-standing installations are owned by the customer. Installation requirements for service to free-standing installations are listed below.

Requirements:

## SECTION 7 General Requirements and Specifications for Electrical Installations

---

1. The customer shall consult Hyrum City Power to determine the location of the freestanding meter installation.
2. The free-standing meter base shall meet all city ordinance requirements.
3. The meter base shall be protected from damage by use of barrier posts or other suitable protection approved prior to installation by Hyrum City Power.
4. The CT cabinet must be properly supported with a minimum of two three-inch (3") steel posts with installed caps, or two wood post no less than 6" x 6" (nominal) and pressure- treated with an American Wood Preservative Association approved preservative. When equipment is less than 72 inches (72") apart, it shall be bonded according to the NESC.
5. The customer shall furnish, install and maintain posts, hardware, conduit, fittings, and concrete pads sufficient to support the metering.

### *7.9.4.6 Combination Direct-Connect and CT Metering*

Installations requiring both direct-connect and CT metering services shall meet the requirements of both types of services as described in the previous sections. An approved wall-mounted equipment installation is shown below. Switchboard combination units are also allowed. Refer to Section 9.5, Switchboard Metering up to 4000 A for requirements.

### 7.9.5 SWITCHBOARD METERING, UP TO 4000 A

This section lists the requirements in addition to the general requirements in this section for switchboard metered service installations. A EUSERC-approved switchboard metering section is required when the service entrance rating is greater than 800 A. Switchboard metering may also be used for three-phase services over 200 A or single-phase services over 400 A.

Consult with Hyrum City Power regarding the design of the switchboard metering services before purchasing and installing equipment.

Requirements:

1. The customer shall provide a drawing of the proposed service equipment, including EUSERC reference numbers and a mounting pad with dimensions, to Hyrum City Power for review and approval. Hyrum City Power approval must be obtained prior to fabrication.
2. The customer shall provide and install:
  - a. Switchboard enclosure with CT compartment
  - b. Meter base

## SECTION 7 General Requirements and Specifications for Electrical Installations

---

- c. Metering conduit-one-inch (1") minimum electrical non-metallic tubing (ENT) or flexible PVC for the metering secondary conductors
  - d. Locking equipment for the meter enclosure
  - e. Concrete mounting pad for the switchboard enclosure
  - f. A flat permanent surface (such as a concrete pad) extending a minimum of 36 inches (36") out from the switchboard in front of the CT compartment
3. The metering CTs shall be located in the CT compartment.
  4. The CT compartment shall have a hinged door.
  5. For a single service, the meter and test switch shall be mounted remotely (outside the cabinet).
  6. Installing two or more metering services requires mounting on the compartments' hinged meter panels.
  7. The metering conduit in the switchboard section shall terminate in the CT compartment in front of the CTs.
  8. The door shall be equipped with a device to hold it in the open position at 90° or more.
  9. Lugs for terminating the customer's ground wire (or other grounding conductors) shall be located outside the sealable section and shall be designed to allow the customer's neutral system to be readily accessible.
  10. All pull and termination sections shall have full front access.
  11. All removable cover panels shall have two lifting handles and be limited to a maximum weight of 25 pounds.
  12. The customer will terminate the line side service conductors on lug landings in the pull section.
  13. Bus bars are required from the pull section for service above 800 amps. Termination lugs are required and shall meet EUSERC 347.
  14. Any customer-owned locking equipment for the metering enclosure must allow independent access by Hyrum City Power.
  15. Only Hyrum City Power service conductors are allowed inside the pull section.

Minimum dimensions for switchboard pull boxes (termination enclosures) are shown in Figure 7 and Table 8:



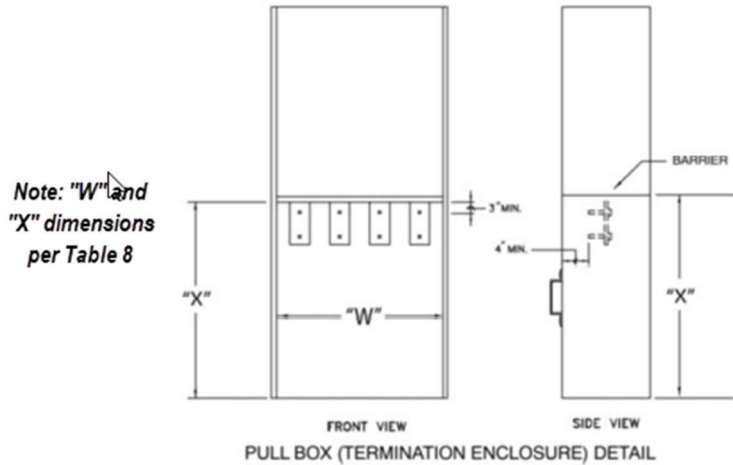

Figure 7 Switchboard Section with Termination Enclosure

Table 8 Minimum Dimensions for Switchboard Pull Box (Termination Enclosures)

Switchboard rating	Minimum Access Opening ("W")		Height Dimension ("X")	
	3-wire Service	4-wire Service	Min.	Max.
Below 400 A	Consult with Hyrum City Power			
400-800 A	24"	24"	42"	72"
801-1200 A	24"	30"		
1201-2000 A	30"	35"		
2001-3000 A	-	42"	60"	
3001-4000 A	-	44"		

## 7.10 STREETLIGHTS

### 7.10.1 SUBDIVISION POLE-TOP LUMINARIES

The customer shall install conduit and secondary junction boxes for streetlights according to the Hyrum City design. Hyrum City Power provides and installs streetlights at the customer's expense. The concrete base for the light pole will be installed by Hyrum City and paid for by the customer.

HYRUM CITY  
Power Department

SECTION 7

STANDARD  
DETAIL  
DRAWINGS

# SECTION 7 General Requirements and Specifications for Electrical Installations

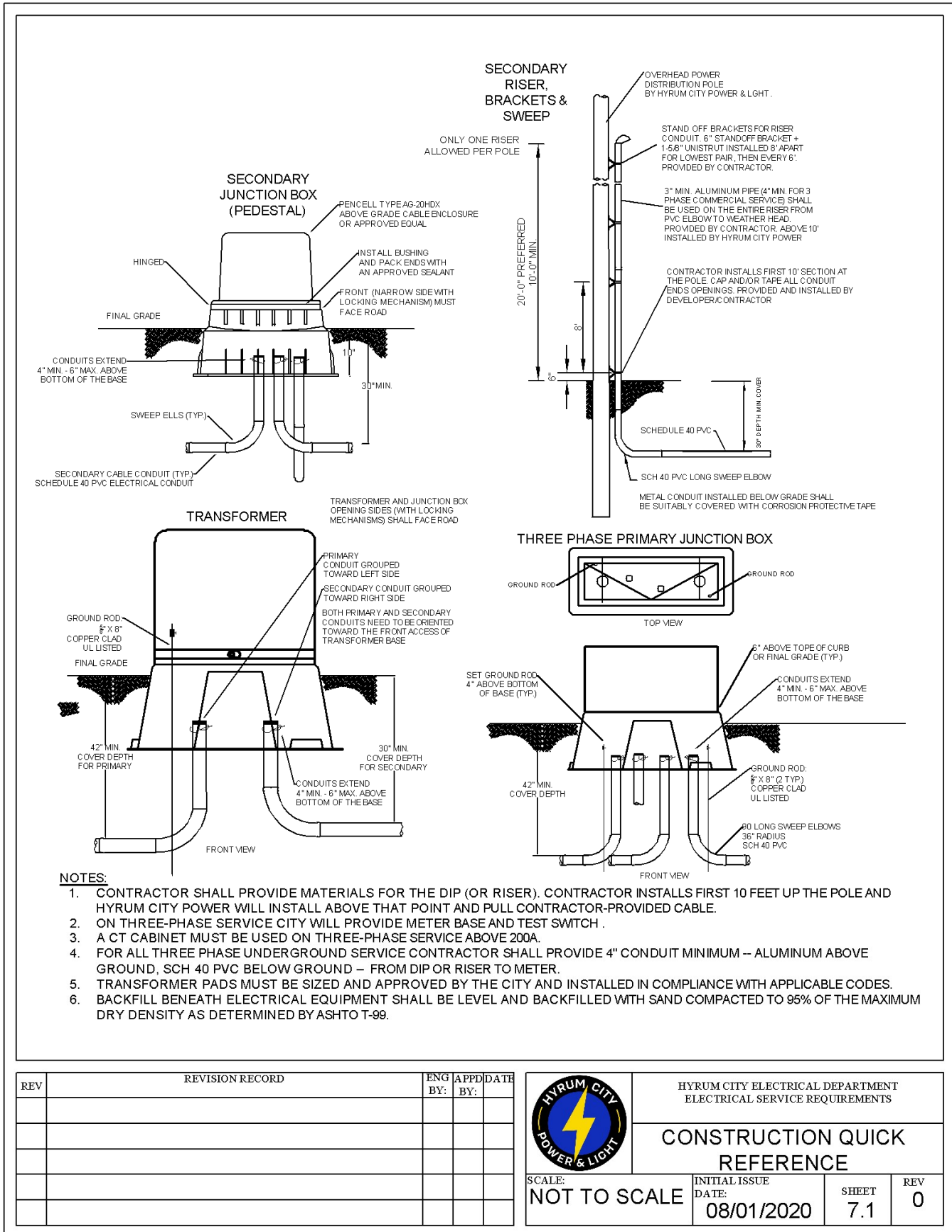

# SECTION 7 General Requirements and Specifications for Electrical Installations

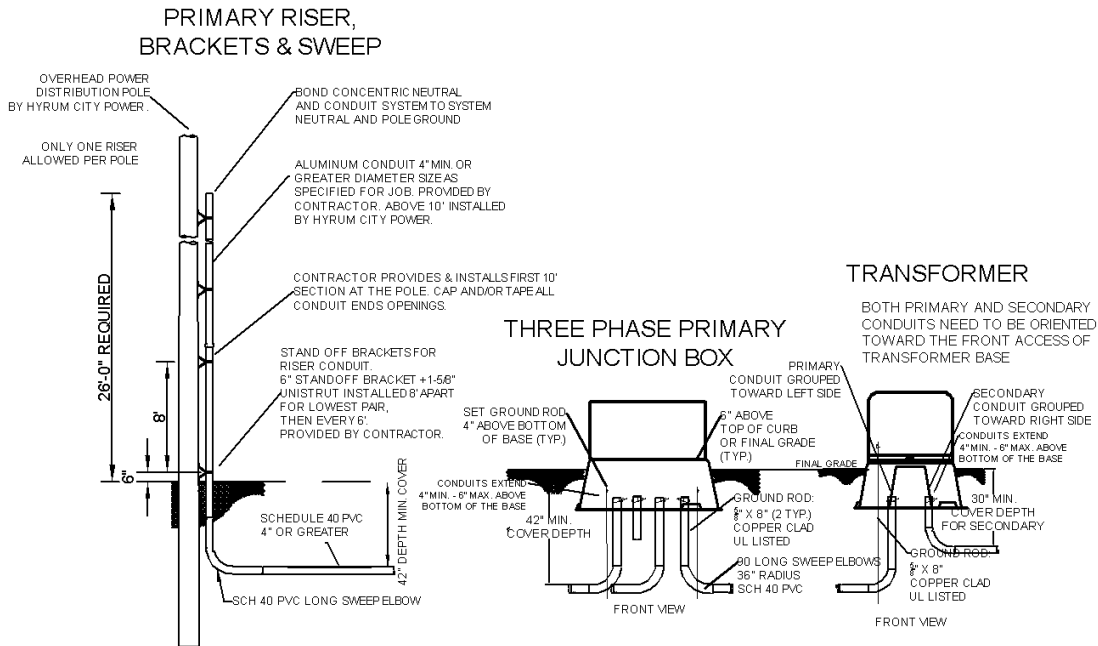

- NOTES:**
1. CONTRACTOR SHALL PROVIDE MATERIALS FOR THE DIP (OR RISER). CONTRACTOR INSTALLS FIRST 10 FEET UP THE POLE AND CITY WILL INSTALL ABOVE THAT POINT AND PULL CONTRACTOR-PROVIDED CABLE.
  2. CITY SHALL PROVIDE METER BASE AND TEST SWITCH ON THREE-PHASE SERVICE.
  3. A CT CABINET MUST BE USED ON THREE-PHASE SERVICE ABOVE 200A.
  4. FOR ALL THREE PHASE UNDERGROUND SERVICE CONTRACTOR SHALL PROVIDE 4" OR GREATER ALUMINUM AND SCHEDULE 40 PVC CONDUIT FROM DIP OR RISER TO METER.
  5. TRANSFORMER PADS MUST BE SIZED AND APPROVED BY THE CITY AND INSTALLED IN COMPLIANCE WITH APPLICABLE CODES.

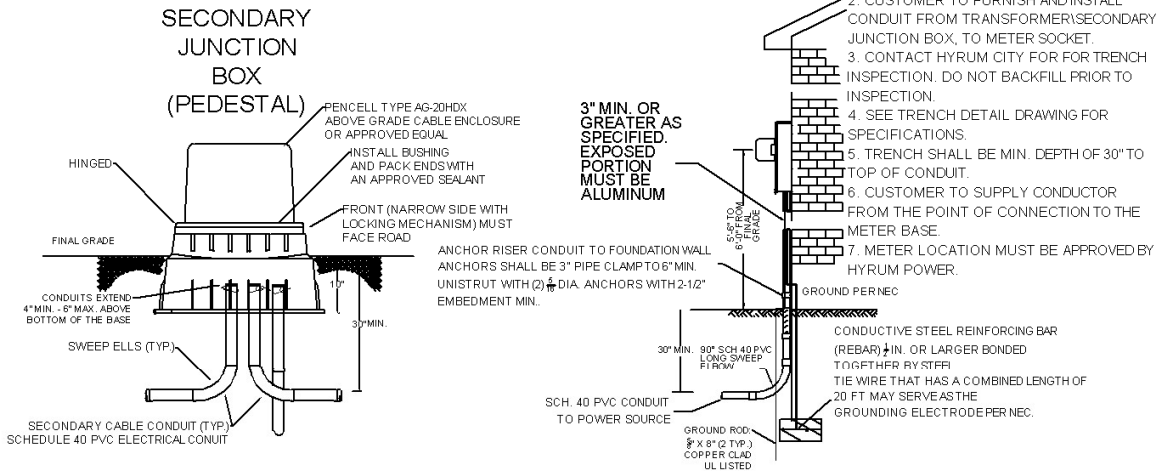

REV	REVISION RECORD	ENG BY:	APPD BY:	DATE

HYRUM CITY ELECTRICAL DEPARTMENT  
ELECTRICAL SERVICE REQUIREMENTS

**TYPICAL INSTALL--PRIMARY,  
SECONDARY & SERVICE**

SCALE: <b>NOT TO SCALE</b>	INITIAL ISSUE DATE: <b>08/01/2020</b>	SHEET <b>7.2</b>	REV <b>0</b>
-------------------------------	---	---------------------	-----------------

SECTION 7 General Requirements and Specifications for Electrical Installations

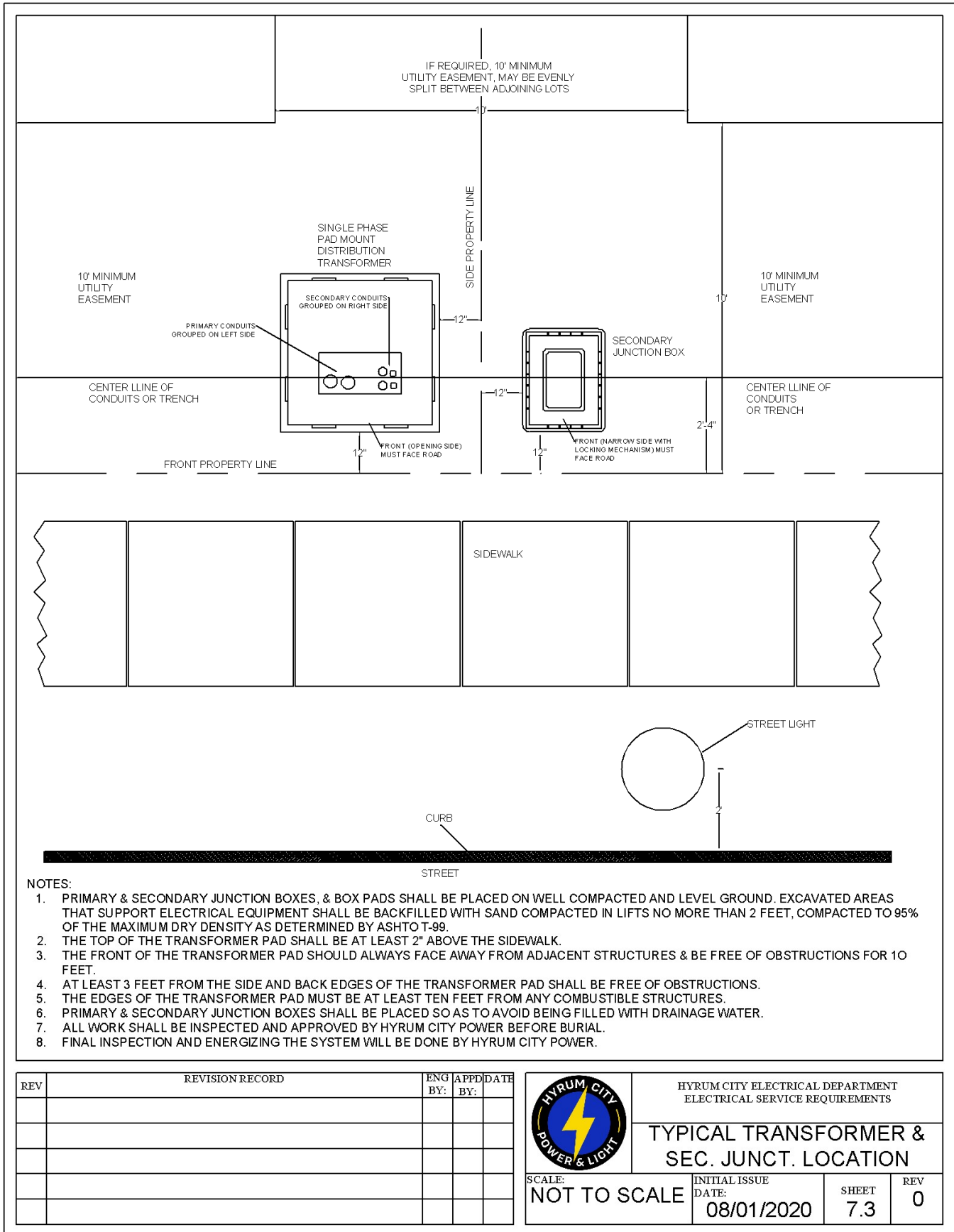

SECTION 7 General Requirements and Specifications for Electrical Installations

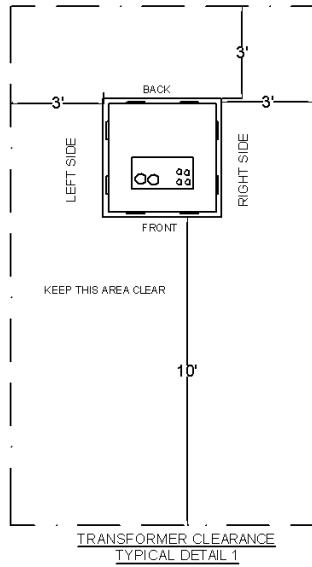

NOTE: A PREFABRICATED OR CONSTRUCTED-ON-SITE CONCRETE PAD SHALL BE USED FOR 100 KVA TRANSFORMER OR LARGER. CONTACT HYRUM CITY ELECTRICAL DEPARTMENT FOR REQUIRED EXACT DIMENSIONS AND APPROVAL.

1. DISTANCES ARE FROM THE EDGE OF THE EQUIPMENT PAD.
2. NO VEGETATION OVER 6" IN HEIGHT SHALL BE ALLOWED IN THE CLEAR AREA.
3. NO TRIP HAZARDS SHALL EXIST IN THE CLEAR AREA.

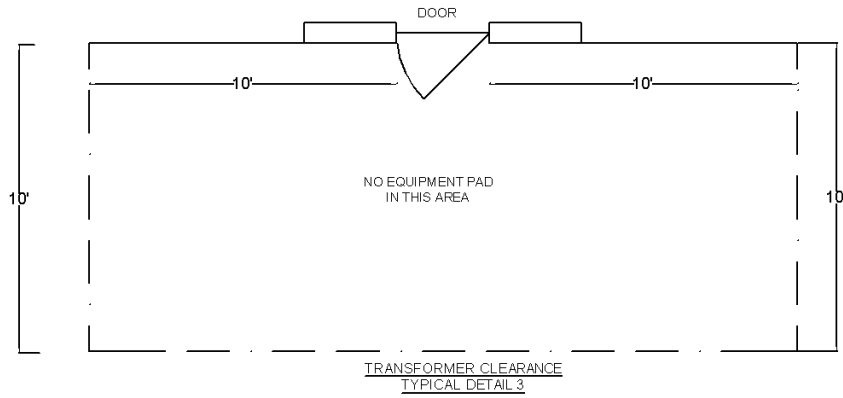
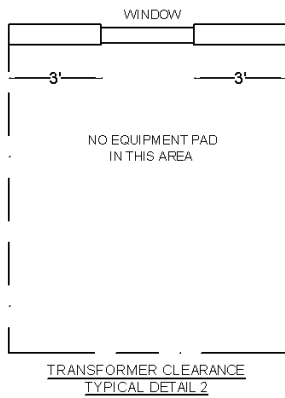

REV	REVISION RECORD	ENG BY:	APPD BY:	DATE

	HYRUM CITY ELECTRICAL DEPARTMENT ELECTRICAL SERVICE REQUIREMENTS		
	<b>TRANSFORMER CLEARANCE</b>		
SCALE: <b>NOT TO SCALE</b>	INITIAL ISSUE DATE: <b>08/01/2020</b>	SHEET <b>7.4</b>	REV <b>0</b>

SECTION 7 General Requirements and Specifications for Electrical Installations

TYPICAL TRANSFORMER AND SERVICE JUNCTION BOX INSTALLATION

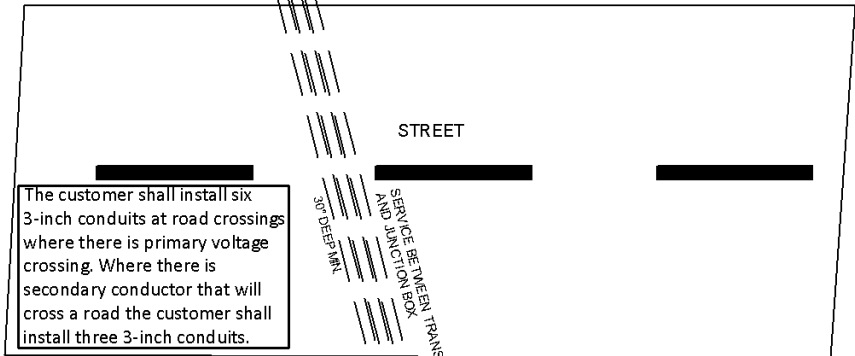
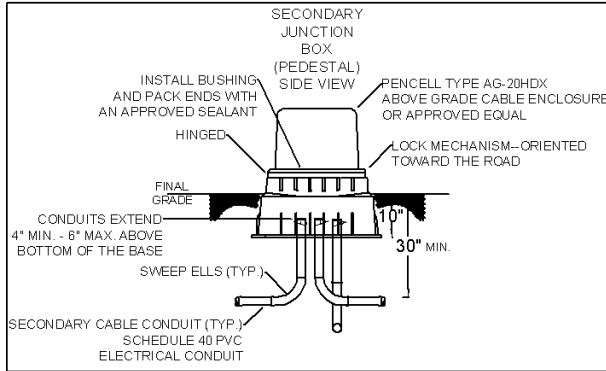
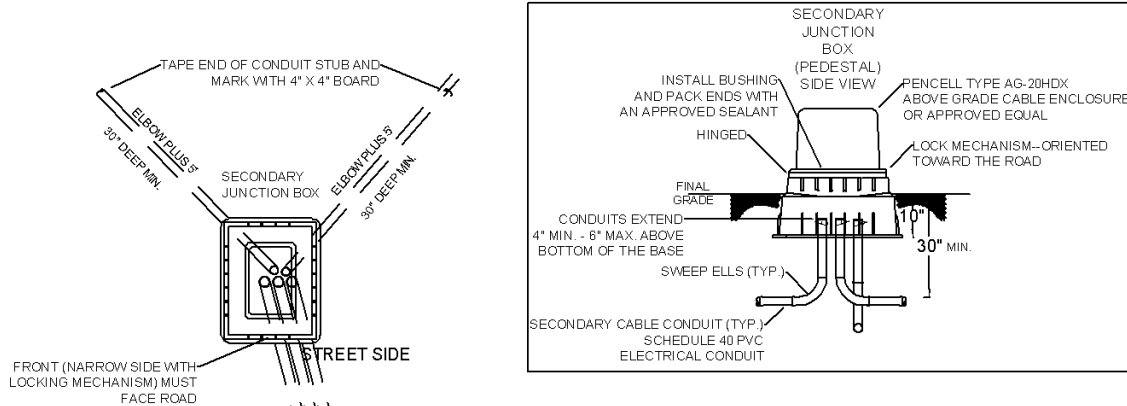

The customer shall install six 3-inch conduits at road crossings where there is primary voltage crossing. Where there is secondary conductor that will cross a road the customer shall install three 3-inch conduits.

ALL ELBOWS NEED TO BE 90° NOT 45°. CONDUITS IN SECONDARY JUNCTION BOXES NEED TO BE TOWARD THE CENTER OF THE BOX.

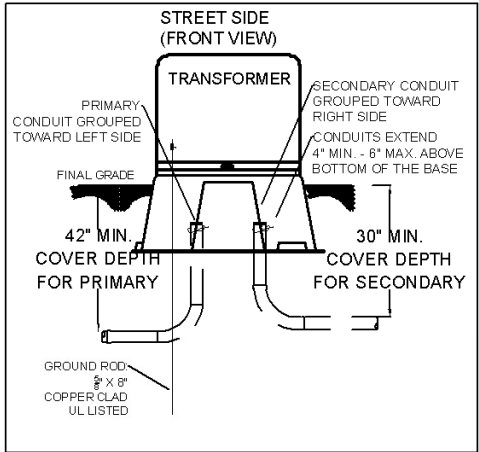
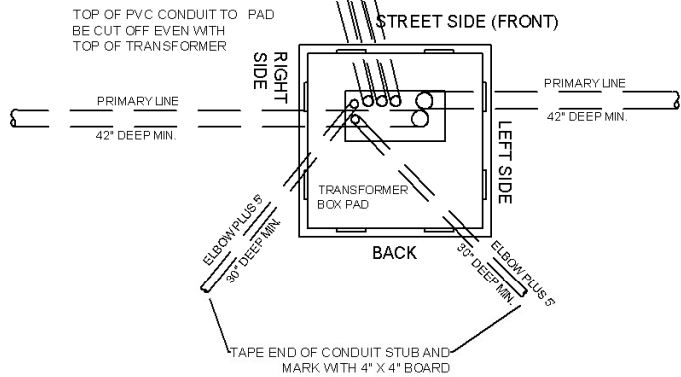

REV	REVISION RECORD	ENG BY:	APPD BY:	DATE

HYRUM CITY ELECTRICAL DEPARTMENT  
ELECTRICAL SERVICE REQUIREMENTS

**TRANSFORMER & SERVICE  
JUNCT. BOX INSTALLATION**

SCALE: <b>NOT TO SCALE</b>	INITIAL ISSUE DATE: <b>08/01/2020</b>	SHEET <b>7.5</b>	REV <b>0</b>
-------------------------------	---	---------------------	-----------------

SECTION 7 General Requirements and Specifications for Electrical Installations

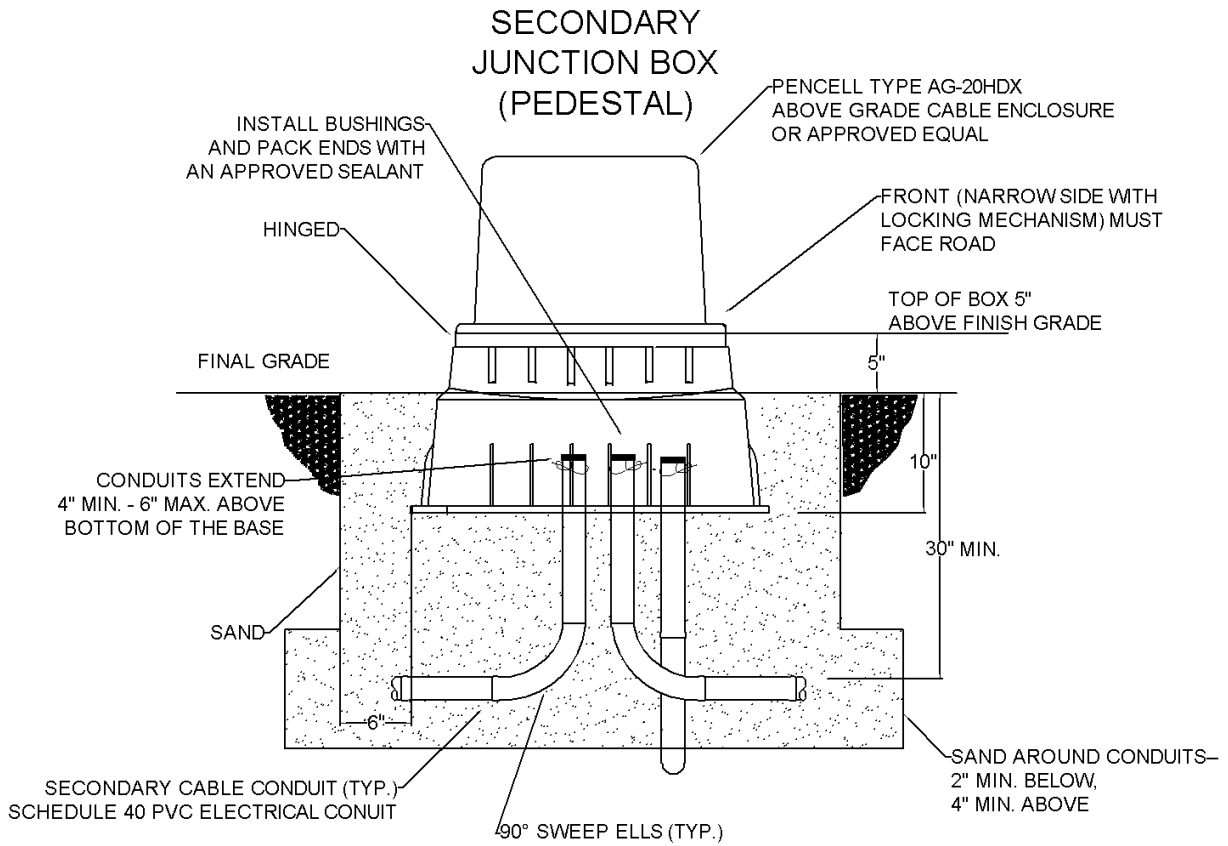

NOTES:

1. AREA AROUND BOX CAN EITHER BE PLANTED, HARD SURFACE OR A COMBINATION.
2. BOXES SHALL BE PLACED SO AS TO AVOID BEING FILLED WITH DRAINAGE WATER.
3. BOXES SHALL BE PLACED LEVEL ON SAND BACKFILL COMPACTED IN LIFTS NO MORE THAN 2 FEET, COMPACTED TO 95% OF THE MAXIMUM DRY DENSITY AS DETERMINED BY ASHTO T-99.
4. ALL WORK SHALL BE INSPECTED AND APPROVED BY HYRUM CITY POWER DEPARTMENT.

REV	REVISION RECORD	ENG BY:	APPD BY:	DATE

	HYRUM CITY ELECTRICAL DEPARTMENT ELECTRICAL SERVICE REQUIREMENTS		
	<b>SECONDARY JUNCTION BOX INSTALLATION</b>		
SCALE: <b>NOT TO SCALE</b>	INITIAL ISSUE DATE: <b>08/01/2020</b>	SHEET <b>7.6</b>	REV <b>0</b>



SECTION 7 General Requirements and Specifications for Electrical Installations

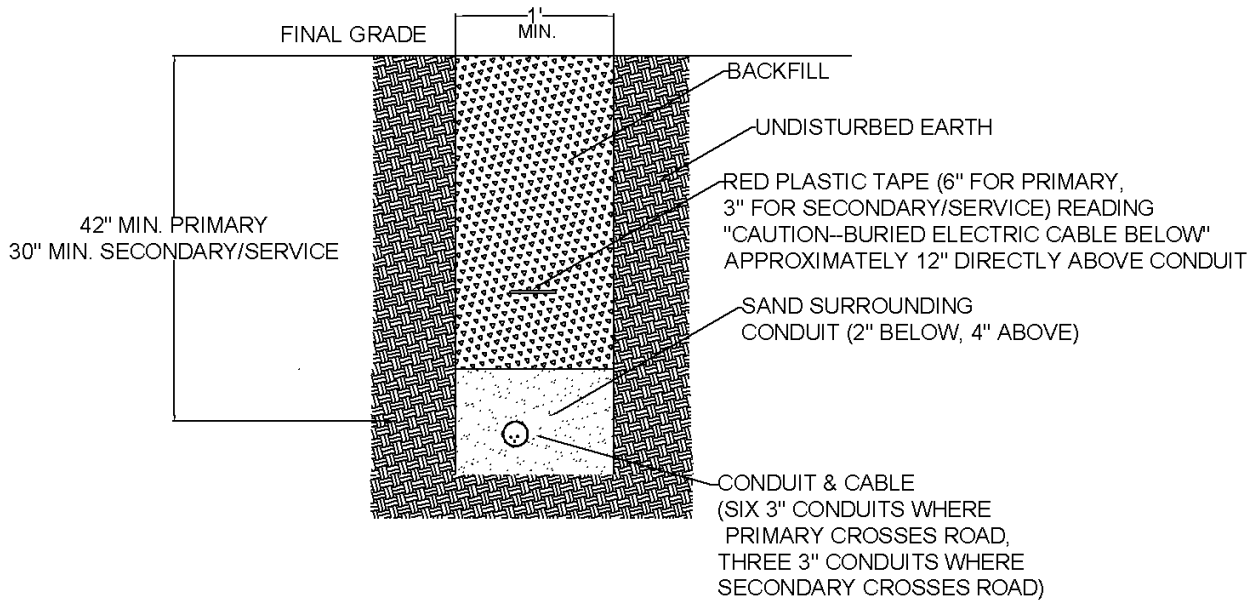

TRENCH DETAIL

REV	REVISION RECORD	ENG BY:	APPD BY:	DATE

	HYRUM CITY ELECTRICAL DEPARTMENT ELECTRICAL SERVICE REQUIREMENTS		
	<b>TRENCH DETAIL</b>		
SCALE: <b>NOT TO SCALE</b>	INITIAL ISSUE DATE: <b>08/01/2020</b>	SHEET <b>7.7</b>	REV <b>0</b>

SECTION 7 General Requirements and Specifications for Electrical Installations

OVERHEAD RESIDENTIAL SERVICES

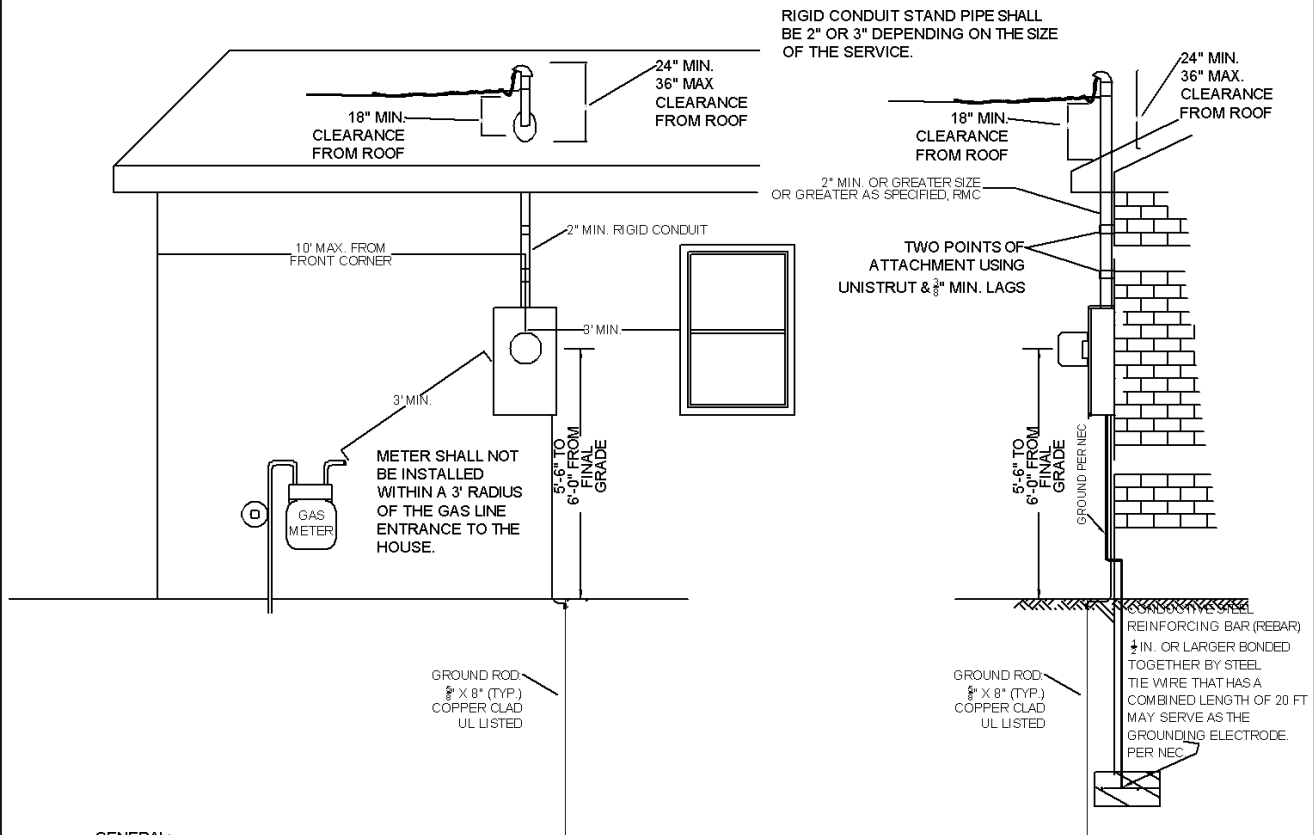

**GENERAL:**

ALL ELECTRICAL WORK SHALL BE IN COMPLIANCE WITH THE LATEST EDITION OF THE NATIONAL ELECTRIC CODE, INTERNATIONAL BUILDING CODE, ICC ELECTRICAL CODE AND THE NATIONAL ELECTRICAL SAFETY CODE EXCEPT WHERE THESE SPECIFICATIONS ARE MORE STRINGENT. IF THERE IS A CONFLICT BETWEEN STANDARDS THE MOST STRINGENT SHALL RULE. HYRUM CITY PROVIDES ALL SERVICE WIRE TO THE METER MAST ON OVERHEAD CONNECTIONS. THE CUSTOMER SHALL PROVIDE SERVICE WIRE FROM THE WEATHER HEAD TO THE METER BASE.

**INSTALLATION:**

1. ADDRESS SHALL BE POSTED AT BUILDING.
2. CUSTOMER TO SUPPLY AND INSTALL CONDUCTOR FROM THE WEATHERHEAD TO THE METER BASE.
3. HYRUM CITY POWER PROVIDES SERVICE WIRE TO THE WEATHERHEAD FROM THE POWER SOURCE.

REV	REVISION RECORD	ENG BY:	APPD BY:	DATE



HYRUM CITY ELECTRICAL DEPARTMENT  
ELECTRICAL SERVICE REQUIREMENTS

**TYPICAL OVERHEAD  
RESIDENTIAL SERVICE**

SCALE: <b>NOT TO SCALE</b>	INITIAL ISSUE DATE: <b>08/01/2020</b>	SHEET <b>7.8</b>	REV <b>0</b>
-------------------------------	---	---------------------	-----------------

SECTION 7 General Requirements and Specifications for Electrical Installations

UNDERGROUND RESIDENTIAL SERVICES

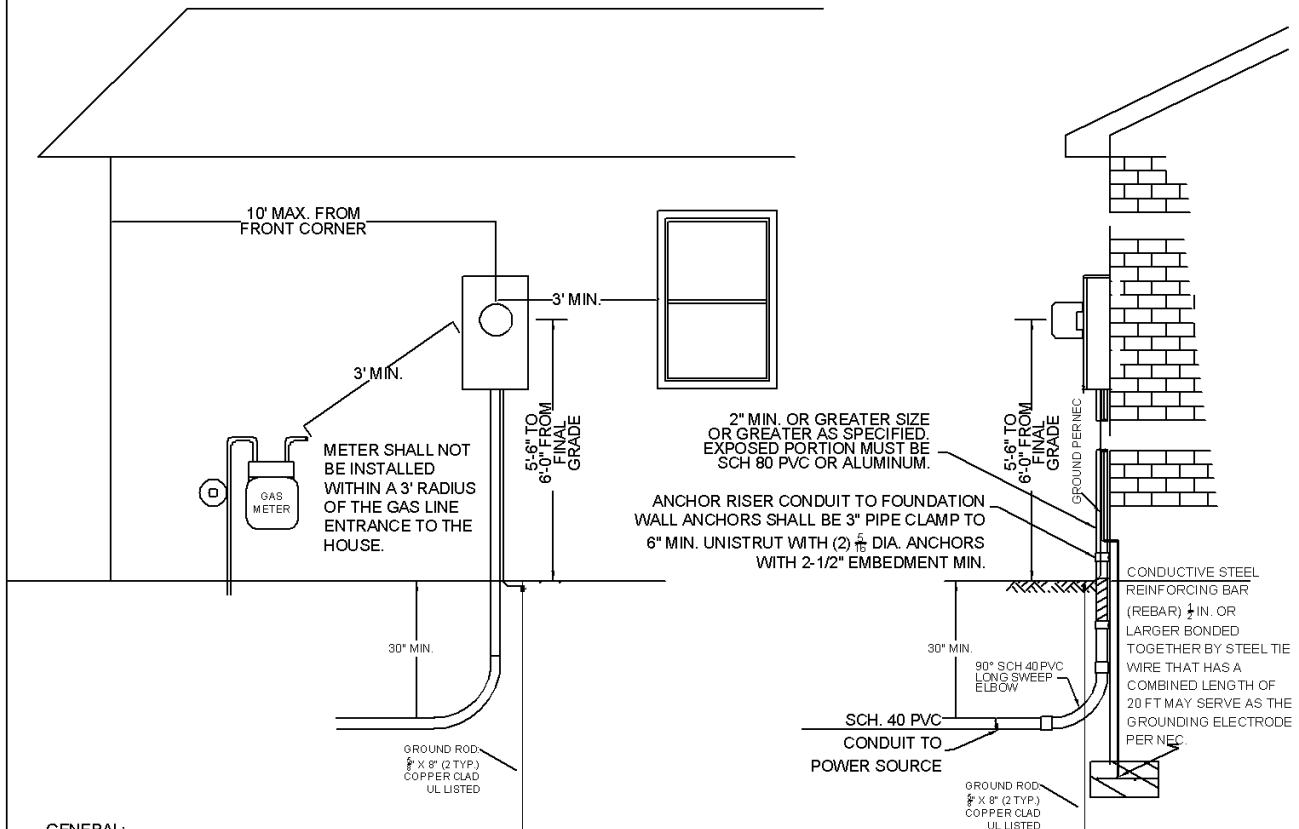

**GENERAL:**  
 ALL ELECTRICAL WORK SHALL BE IN COMPLIANCE WITH THE LATEST EDITION OF THE NATIONAL ELECTRIC CODE, INTERNATIONAL BUILDING CODE, ICC ELECTRICAL CODE AND THE NATIONAL ELECTRICAL SAFETY CODE EXCEPT WHERE THESE SPECIFICATIONS ARE MORE STRINGENT. IF THERE IS A CONFLICT BETWEEN STANDARDS THE MOST STRINGENT SHALL RULE. THE CUSTOMER SHALL PROVIDE ALL SECONDARY SERVICE WIRE FROM THE POINT OF CONNECTION TO THE METER BASE ON UNDERGROUND SERVICES. CUSTOMER SHALL PROVIDE CONDUIT IN PLACE. THE CITY'S ELECTRICAL DEPARTMENT WILL PULL THE SECONDARY SERVICE WIRE.

**INSTALLATION:**

1. ADDRESS SHALL BE POSTED AT BUILDING.
2. CUSTOMER TO FURNISH AND INSTALL CONDUIT FROM TRANSFORMER\ OR SECONDARY JUNCTION BOX, TO METER BASE.
3. CONTACT HYRUM CITY FOR FOR TRENCH INSPECTION. DO NOT BACKFILL PRIOR TO INSPECTION.
4. SEE TRENCH DETAIL DRAWING FOR SPECIFICATIONS.
5. TRENCH SHALL BE MIN. DEPTH OF 30" TO TOP OF CONDUIT.
6. CUSTOMER TO SUPPLY CONDUCTOR FROM THE POINT OF CONNECTION TO THE METER BASE.
7. METER LOCATION MUST BE APPROVED BY HYRUM CITY POWER.
8. A CT CABINET MUST SE USED ON THREE-PHASE SERVICE ABOVE 200 A.
9. FOR ALL THREE-PHASE UNDERGROUND SERVICE, CONTRACTOR SHALL PROVIDE 4" IMC (MINIMUM) FROM DIP OR RISER TO METER.

REV	REVISION RECORD	ENG BY:	APPD BY:	DATE

HYRUM CITY ELECTRICAL DEPARTMENT  
ELECTRICAL SERVICE REQUIREMENTS

**TYPICAL UNDERGROUND  
RESIDENTIAL SERVICE**

SCALE: <b>NOT TO SCALE</b>	INITIAL ISSUE DATE: <b>04/11/2022</b>	SHEET <b>7.9</b>	REV <b>1</b>
-------------------------------	---	---------------------	-----------------

SECTION 7 General Requirements and Specifications for Electrical Installations

THREE PHASE TRANSFORMER PAD WITH METERING STATION

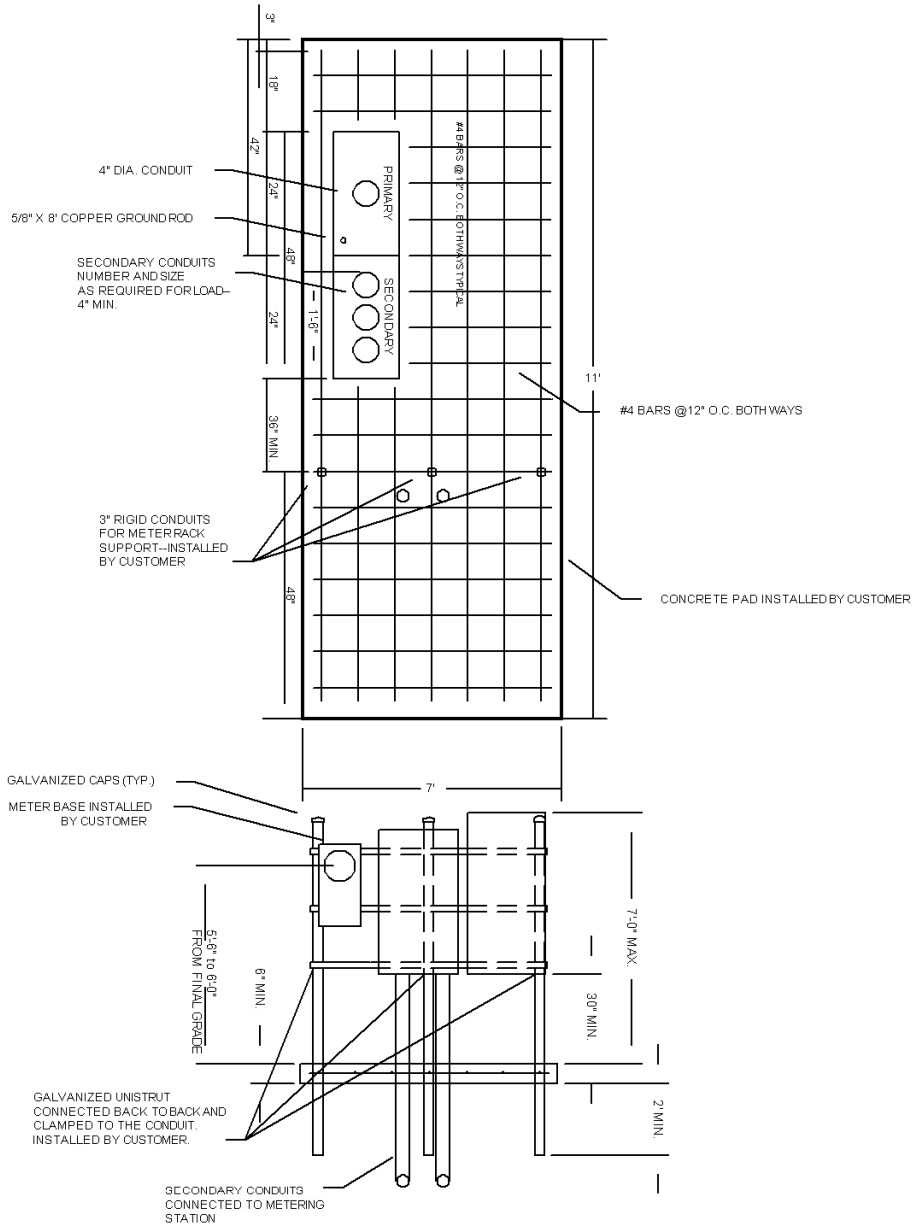

NOTES:

1. SECONDARY CONDUIT NUMBER AND SIZE SHALL BE INSTALLED AS REQUIRED FOR LOAD.
2. CUSTOMER SHALL MAKE SECONDARY/SERVICE WIRE CONNECTIONS IN TRANSFORMER AND METERING STATION.
3. HYRUM CITY POWER WILL PERFORM CT METER WIRING.
4. TRANSFORMER PAD AND METERING STATION SITE SHALL BE LEVEL AND BACKFILLED WITH SAND COMPACTED TO 95% OF THE MAXIMUM DRY DENSITY AS DETERMINED BY ASHTO T-99.

REV	REVISION RECORD	ENG BY:	APPD BY:	DATE



HYRUM CITY ELECTRICAL DEPARTMENT  
ELECTRICAL SERVICE REQUIREMENTS

TYPICAL TRANSFORMER PAD W/ METER STATION

SCALE:  
NOT TO SCALE

INITIAL ISSUE DATE:  
08/01/2020

SHEET  
7.10

REV  
0

SECTION 7 General Requirements and Specifications for Electrical Installations

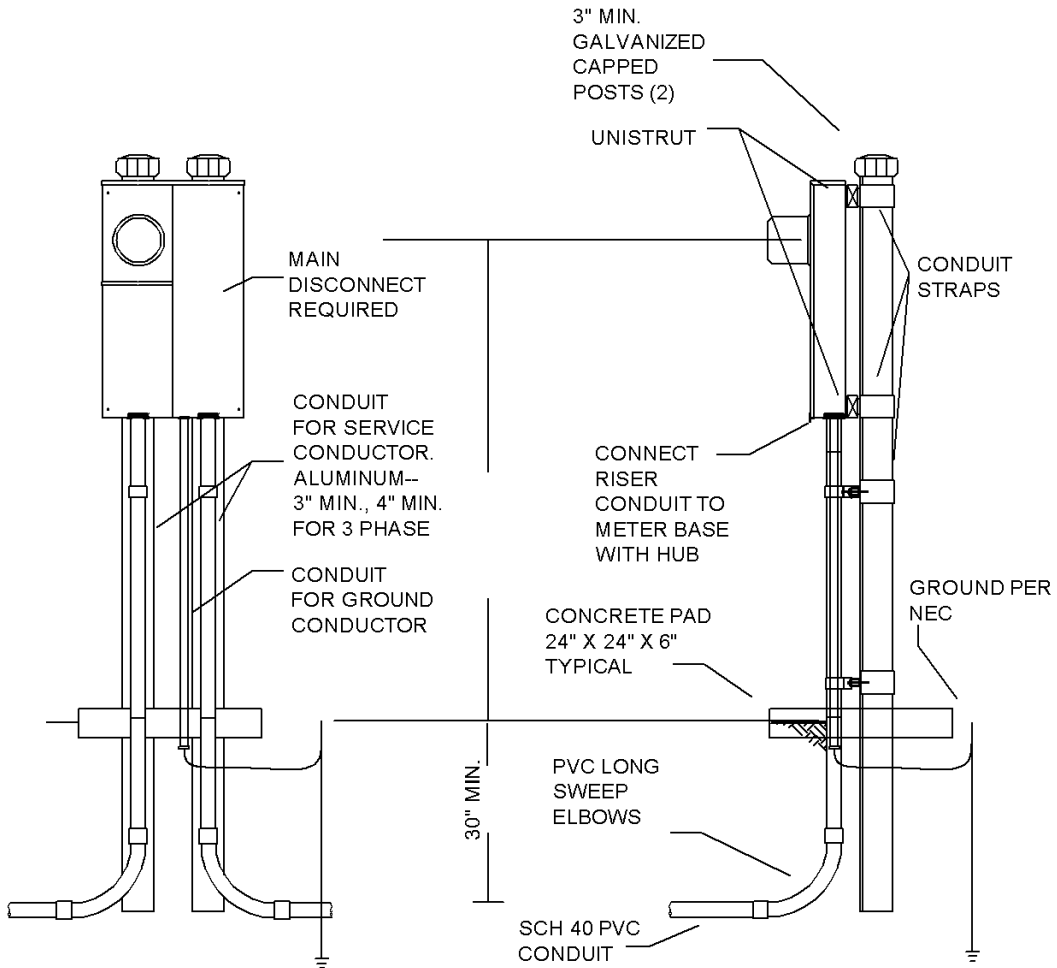

FREE STANDING METER INSTALLATION  
1 OR 3 PHASE

REV	REVISION RECORD	ENG BY:	APPD BY:	DATE



HYRUM CITY ELECTRICAL DEPARTMENT  
ELECTRICAL SERVICE REQUIREMENTS

TYPICAL FREE STANDING  
METER SERVICE

SCALE:  
NOT TO SCALE

INITIAL ISSUE  
DATE:  
08/01/2020

SHEET  
7.11

REV  
0

SECTION 7 General Requirements and Specifications for Electrical Installations

Padvault for Three Phase Transformer

OLDCASTLE PRECAST -- 4'x6' INTERIOR DIMENSION

2.4 - 25KV, 3-PHASE TRANSFORMER PADVAULT WITH ACCESS

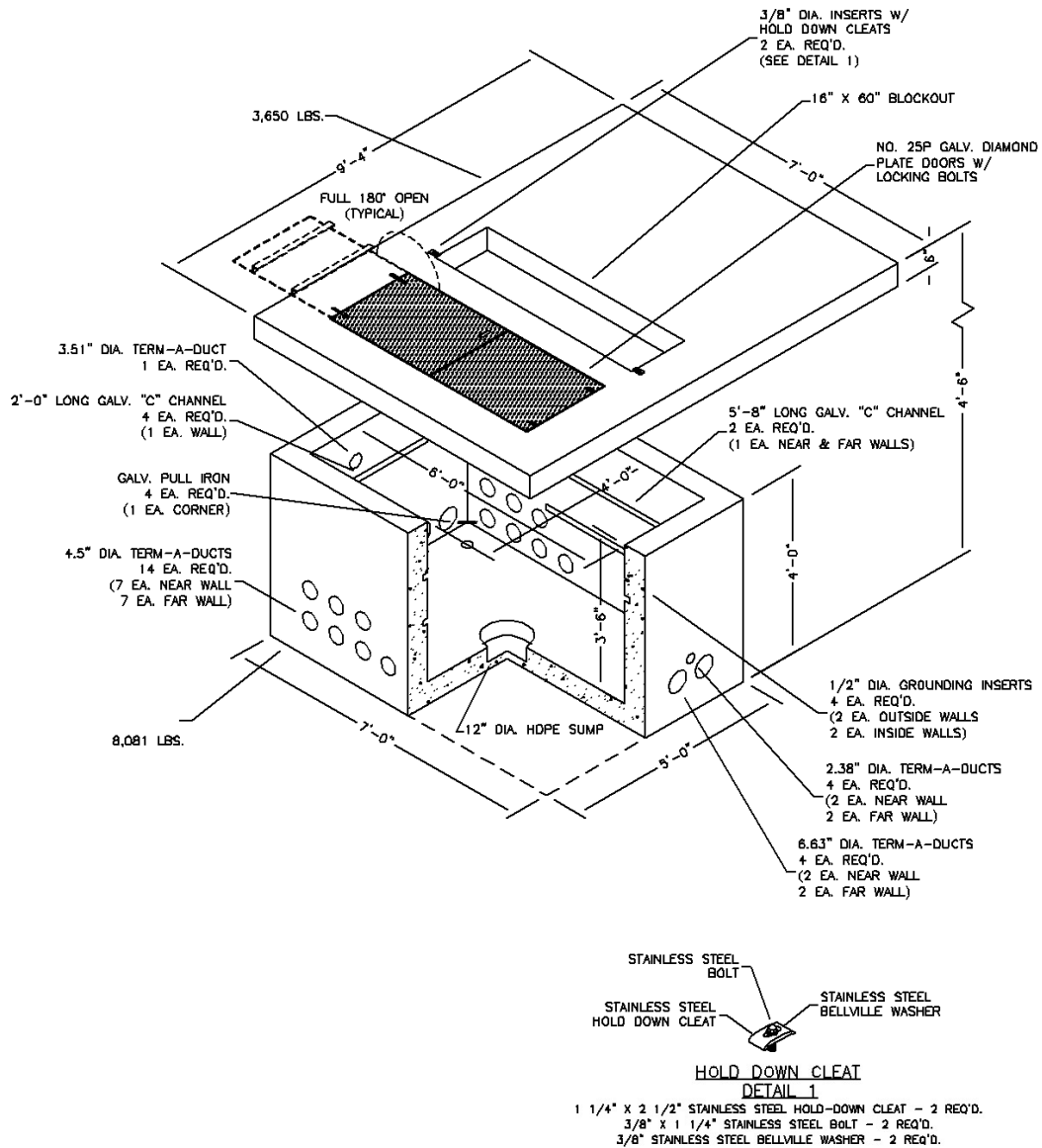

REV	REVISION RECORD	ENG BY:	APPD BY:	DATE

	HYRUM CITY ELECTRICAL DEPARTMENT ELECTRICAL SERVICE REQUIREMENTS		
	<b>THREE PHASE TRANSFORMER PADVAULT</b>		
SCALE: <b>NOT TO SCALE</b>	INITIAL ISSUE DATE: <b>08/01/2020</b>	SHEET <b>7.12</b>	REV <b>0</b>

SECTION 7 General Requirements and Specifications for Electrical Installations

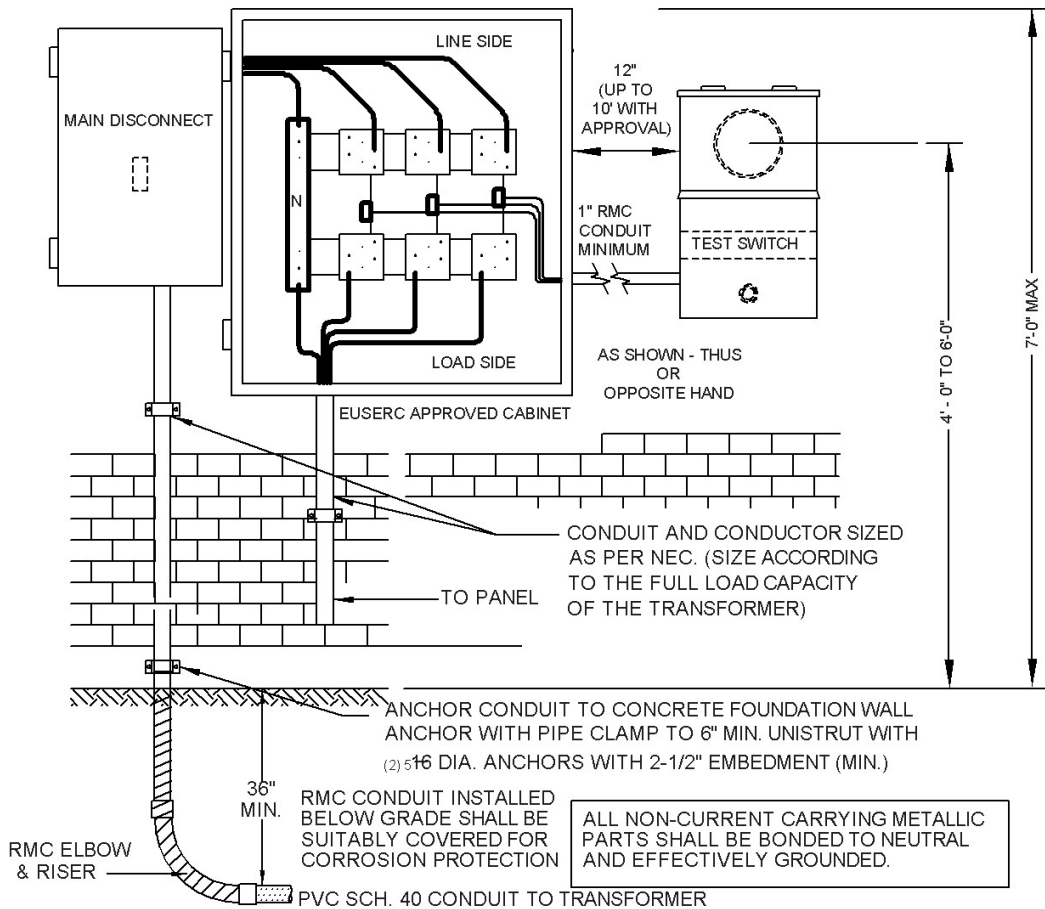

NOTES:

1. EUSERC APPROVED CT CABINET & METER BASE SHALL BE SEALABLE & LOCKABLE BY HYRUM CITY POWER.
2. MAIN SERVICE DISCONNECT IS REQUIRED OUTSIDE AT THE METER LOCATION
3. INSTALLATION LOCATION SHALL BE APPROVED BY HYRUM CITY POWER.
4. CONDUIT CLAMPS MUST BE ABOVE GROUND.
5. CONTRACTOR SHALL SUPPLY AND TERMINATE SECONDARY CONDUCTORS AT TRANSFORMER.
6. INSPECTION REQUIRED PRIOR TO BACK FILL OF TRENCH.
7. INSPECTION REQUIRED PRIOR TO PERMANENT POWER CONNECTION.
8. OWNER/BUILDER SHALL SUPPLY AND INSTALL PER NEC REQUIREMENTS AND MAINTAIN CONDUIT AND CONDUCTORS FROM THE CT ENCLOSURE TO THE POWER SOURCE SUPPLIED BY HYRUM CITY POWER.

REV	REVISION RECORD	ENG BY:	APP BY:	DATE

HYRUM CITY ELECTRICAL DEPARTMENT  
ELECTRICAL SERVICE REQUIREMENTS

**THREE PHASE CT METERING**

SCALE: <b>NOT TO SCALE</b>	INITIAL ISSUE DATE: <b>12/01/2020</b>	SHEET <b>7.13</b>	REV <b>0</b>
-------------------------------	---	----------------------	-----------------