



CERTIFICATE OF APPROPRIATENESS APPLICATION

REQUIRED MATERIALS CHECKLIST

Community Development Department
100 N King St.
Hendersonville, NC 28792
828-697-3010

Procedures for Reviewing Applications for Certificates Appropriateness

The City's Historic Preservation Ordinance provides that no one may erect, alter, restore, move, or demolish the exterior portion of any building or other structure, nor undertake significant modifications to landscaping and other site features, without a Certificate of Appropriateness (COA) which must be approved prior to the commencement of work. The COA application is processed through the city of Hendersonville Planning Department by the Commission Coordinator (828-697-3010).

All COA applications are **due 30 days prior** to the next regular Commission meeting date. The Historic Preservation Commission meets the **third Wednesday of each month at 5pm in the 2nd Floor Meeting Room located at City Hall (160 6th Ave E.).**

Application Submittal Requirements and Required Materials Checklist

Design Standards, HPC Meeting Schedule and Staff Contact Information can be found on the City of Hendersonville Historic Preservation Commission Website: www.hendersonvillehpc.org

Date: 1.14.2025 Minor Work Major Work Major Work Resubmittal

Application Contact Information			
Applicant Name: PEACOCK ARCHITECTS	Property Address: 129 3RD AVENUE W HENDERSONVILLE, NC 28792	Applicant Email: TAMARA@PEACOCKARCHITECT.COM	Phone Number: (828)6969-4000
Property Owner Name (if different from Applicant) HVL PROPERTY MANAGEMENT	Mailing Address: PO BOX 786 ARDEN NC 28704	Owner Email: JOSHDISRAEL@GMAIL.COM	Phone Number: (828)606-3453

COA Project Description – The burden of proof is on the Applicant to prove the proposed work is in keeping with the historical character of the district. Please list specific references in the Design Standards that support your application.

Request for Approval: Renovation of the Front Façade – 344 Main Street (J.C. Penney Building), Hendersonville, NC
Peacock Architects respectfully submits this proposal for approval to renovate the front façade of 344 Main Street, also known as the J.C. Penney building, in Hendersonville, NC. In conjunction with the interior redesign, which includes subdividing the space into two leasable units, we propose installing a new storefront.
The proposed design features two double-door entries, each serving one of the units, integrated into a glass storefront reminiscent of the building's historical character. This design includes a recessed entry canopy, consistent with the historical storefront typology prevalent in Hendersonville.
Our attached drawings and photographs document our investigation of the existing façade materials beneath the current metal screen. We have confirmed that the underlying brick is in excellent condition.
Additionally, we seek approval to replace the existing double doors in the back alley, which measure 4' in width by 6'-1" in height. The replacement will use standard flat-panel metal doors while maintaining the original door opening dimensions. This change is necessary to enhance security and meet current fire code requirements.
Throughout the design process, we have adhered to the guidelines outlined in the Main Street Guidelines Manual as follows:
Preservation of Historic Features: Retain entryways, display windows, doors, transoms, and corner posts (Section 3.1.1).
Avoid removing or altering historical features: Avoid removing or altering historical features (Section 3.1.2).
Historical Accuracy: Base the new storefront design on historical research and evidence (Section 3.1.5).
Retention of Façade Details: Preserve historic façade details and materials, especially on side and rear elevations (Section 3.3.1).



CERTIFICATE OF APPROPRIATENESS APPLICATION

Community Development Department
100 N King St.
Hendersonville, NC 28792

Property Owner Signature

I, the undersigned, certify that all information in this application and in any attachments thereto is accurate to the best of my knowledge. Furthermore, I understand that should a certificate of appropriateness be issued, such certificate will be valid for a period of six months from the date of issuance. Failure to procure a building permit within that period will be considered as failure to comply with the certificate, and the certificate will become invalid. If a building permit is not required, the authorized work must be completed within six (6) months. Certificates can be extended for six (6) months by requesting an extension in writing prior to their expiration from the Commission Coordinator.

Josh Israel

Printed Property Owner(s) Name

Josh Israel

Property Owner(s) Signature

HVL Property Holdings

Printed Company Name (if applicable)

*LLC, Inc., Trust

Member

Property Owner Title (if applicable)

*Member, Manager, Register Agent, etc.

Community Development Use Only

Date Received: _____

Received By: _____

Application Complete: Y / N

Proposed HPC Meeting Date (if applicable): _____

Notes:



CERTIFICATE OF APPROPRIATENESS APPLICATION

Community Development Department
100 N King St.
Hendersonville, NC 28792

GENERAL APPLICATION REQUIREMENTS (FOR MINOR & MAJOR WORKS):	
Note: These items are <u>required</u> as part of a complete application package. Incomplete application packages <u>will not</u> move forward in the review process and will result in additional processing and review time.	
<input type="checkbox"/>	Pre-Application Meeting with City Staff (Required for Major Work only)
<input type="checkbox"/>	Detailed Project Description
<input type="checkbox"/>	Color/Labeled Photographs of Subject Property
<input type="checkbox"/>	Property Owner(s) Signature
MINOR WORK REQUIREMENTS	
Fences and Walls	
<input type="checkbox"/>	Site Plan showing proposed location of fencing or wall (include dimensions)
<input type="checkbox"/>	Rendering of proposed fence or wall style.
<input type="checkbox"/>	Material Information (i.e. <i>brickwork, stucco, stone, concrete, wood, cast iron, and wrought iron</i>)
Landscaping Projects	
<input type="checkbox"/>	Site Plan showing location of proposed unit.
<input type="checkbox"/>	Mechanical Unit & Pad Specifications clearly indicating dimensions.
<input type="checkbox"/>	Image showing location of unit and any proposed lines.
<input type="checkbox"/>	Screening type - i.e. shrubbery, fencing, or other.
Rooftop Construction	
<input type="checkbox"/>	Manufacturer Specifications , including material color.
<input type="checkbox"/>	Roof Plan , showing location of rooftop mounted utility, access, or safety structures
Installation of Mechanical and Utility Equipment	
<input type="checkbox"/>	Site Plan , showing location of proposed equipment
<input type="checkbox"/>	Screening type , i.e. shrubbery, fencing, or other.
Foundation Repairs	
<input type="checkbox"/>	Photographs showing existing conditions.
<input type="checkbox"/>	Material information for any new material.
Masonry Repairs	
<input type="checkbox"/>	Photographs showing existing conditions.
<input type="checkbox"/>	Material information for any new material.
Awnings	
<input type="checkbox"/>	Rendering showing location of awning.
<input type="checkbox"/>	Material information , cloth, canvas, acrylic, or other
Removal of Artificial Siding	
<input type="checkbox"/>	Photographs showing existing conditions.
<input type="checkbox"/>	Original siding information and description of work , repair, repaint or replacement of original siding



CERTIFICATE OF APPROPRIATENESS APPLICATION

Community Development Department
100 N King St.
Hendersonville, NC 28792

Existing Stairs, Landing, Steps and Entryways	
<input type="checkbox"/>	Photographs showing existing conditions.
<input type="checkbox"/>	Rendering of proposed exterior stairs, landing, steps, or entryway styles
<input type="checkbox"/>	Material information for any new material.
Replacement of Missing Details	
<input type="checkbox"/>	Photographs showing existing conditions.
<input type="checkbox"/>	Rendering of proposed siding, trim, porch floors, ceilings, columns & balustrade or other architectural features
<input type="checkbox"/>	Material information for any new material.
Replacement of Upper Façade Windows (Main Street Local Historic District)	
<input type="checkbox"/>	Photographs showing existing conditions and number of windows to be replaced
<input type="checkbox"/>	Material information for any new material.
Removal of Accessory Buildings (not original to the site)	
<input type="checkbox"/>	Photographs showing existing conditions.
<input type="checkbox"/>	Site Plan indicating location of accessory building
Accessibility	
<input type="checkbox"/>	Site Plan indicating location of temporary structure.
<input type="checkbox"/>	Material Information
Decks (Main Street Local Historic District)	
<input type="checkbox"/>	Existing and Proposed Site Plans (drawn to scale; include entire site).
<input type="checkbox"/>	Existing and Proposed Elevation Drawings (drawn to scale; side and rear elevations).
<input type="checkbox"/>	Railing Detail Drawing
<input type="checkbox"/>	Material Information
Other Miscellaneous Work Not Listed	
<input type="checkbox"/>	Contact City Staff if you are not sure what is required for your scope of work.
MAJOR WORK REQUIREMENTS	
New Construction, Additions & Accessory Structures	
<input type="checkbox"/>	Materials Worksheet (Not required for Additions)
<input type="checkbox"/>	Existing & Proposed Site Plans (drawn to scale)
<input type="checkbox"/>	Existing & Proposed Floor Plans (drawn to scale)
<input type="checkbox"/>	Existing & Proposed Elevation Drawings (drawn to scale)
<input type="checkbox"/>	Tree Removal & Protection Plan (drawn to scale)
<input type="checkbox"/>	Landscaping Plan
<input type="checkbox"/>	Streetscape Rendering (Required for new structures sited adjacent to a right of way))
<input type="checkbox"/>	Manufacturer Specifications for All Materials (Including but not limited to windows, doors, siding, roofing, lighting, mechanical)

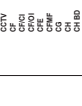
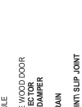
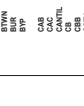
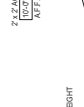
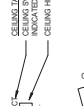
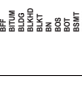
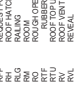
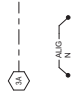
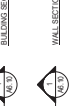
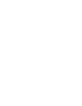
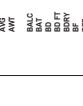
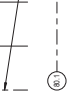
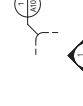
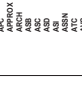
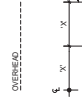
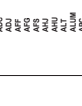
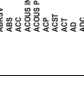
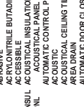
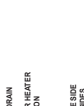
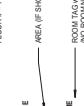
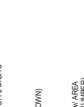
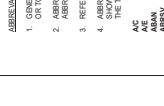
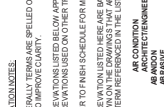
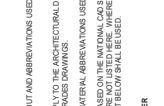
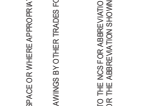
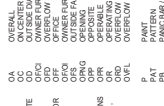
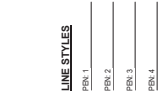
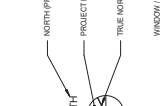
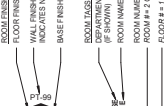

Revision	Date	Issued For

THIS DOCUMENT IS THE PROPERTY OF PEACOCK ARCHITECTS, INC. IT IS TO BE USED ONLY FOR THE PROJECT AND SITE SPECIFICALLY IDENTIFIED HEREIN. IT IS NOT TO BE REPRODUCED, COPIED, OR TRANSMITTED IN ANY FORM OR BY ANY MEANS, ELECTRONIC OR MECHANICAL, INCLUDING PHOTOCOPYING, RECORDING, OR BY ANY INFORMATION STORAGE AND RETRIEVAL SYSTEM, WITHOUT THE WRITTEN PERMISSION OF PEACOCK ARCHITECTS, INC. THE USER OF THIS DOCUMENT AGREES TO HOLD PEACOCK ARCHITECTS, INC. HARMLESS FROM ANY AND ALL LIABILITY, INCLUDING REASONABLE ATTORNEY'S FEES, ARISING FROM OR OUT OF SUCH REPRODUCTION, COPIING, OR TRANSMISSION.

DATE: 11/02/2016 11:54 AM
CHECKED BY: [Signature]
DATE: 11/02/2016
BY: [Signature]
SCALE: 1/8" = 1'-0"

- NOTE:**
1. ALL DIMENSIONS SHOWN ARE MINIMUMS.
 2. DIMENSIONS AND CLEARANCES SHOWN MUST BE PROVIDED AT ALL DOORS.
 3. CONTRACTOR SHALL REVIEW LAYOUT AND CONFIRM THAT ALL OF THE DIMENSIONS AND CLEARANCES SHOWN ARE CORRECT AND THAT ALL OF THE DOORS AND CLEARANCES SHOWN ARE FEASIBLE. ANY DIMENSIONS THAT SHOULD BE REVISED BY THE ARCHITECTS AT THE ARCHITECTS' ATTENTION SHOULD BE BROUGHT TO THE ARCHITECTS' ATTENTION AND REVISIONS THAT SHOULD BE MADE SHOULD BE INDICATED BY THE ARCHITECTS' ATTENTION.

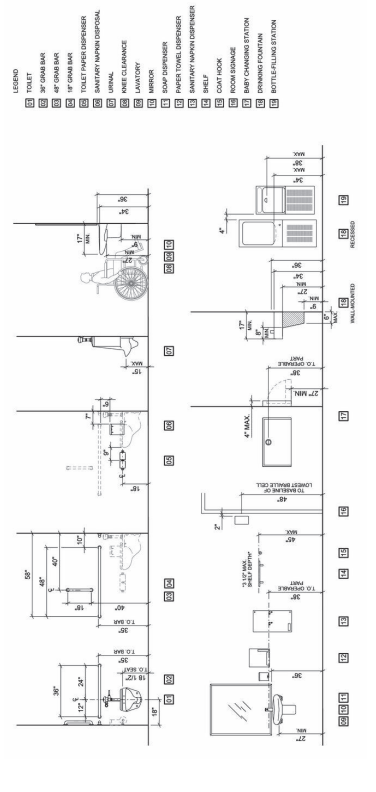

ADA Mounting Heights
 1/8" = 1'-0"

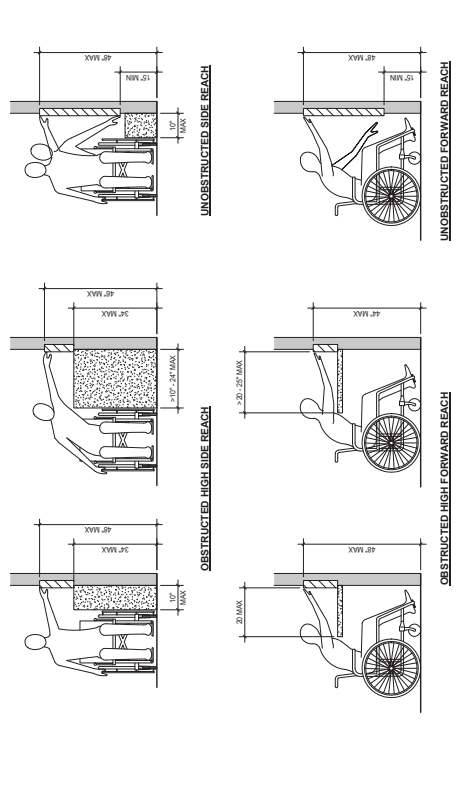

ADDITIONAL GENERAL: THE FOLLOWING TABLE PROVIDES GUIDANCE ON REACH RANGES FOR CHILDREN ACCORDING TO AGE WHERE BUILDING ELEMENTS SUCH AS COUNTERS, LOCKERS, OR OPERABLE PARTS ARE LOCATED OUTSIDE THESE RANGES BUT MUST BE WITHIN THE ADULT REACH RANGES REQUIRED BY 308.

CHILDREN REACH RANGES	AGES 3 AND 4	AGES 5 THROUGH 8	AGES 9 THROUGH 12
FORWARD OR SIDE REACH	36"	40"	44"
HIGH (MAX)	39"	40"	44"
LOW (MIN)	28"	30"	36"

REACH RANGES

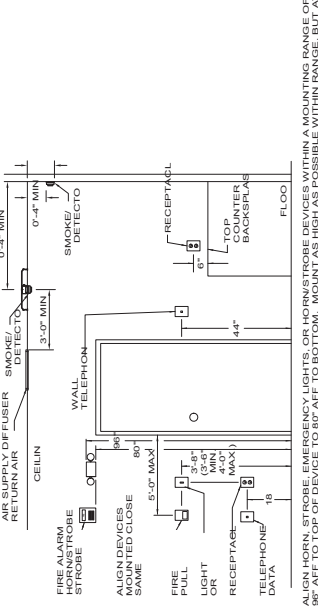
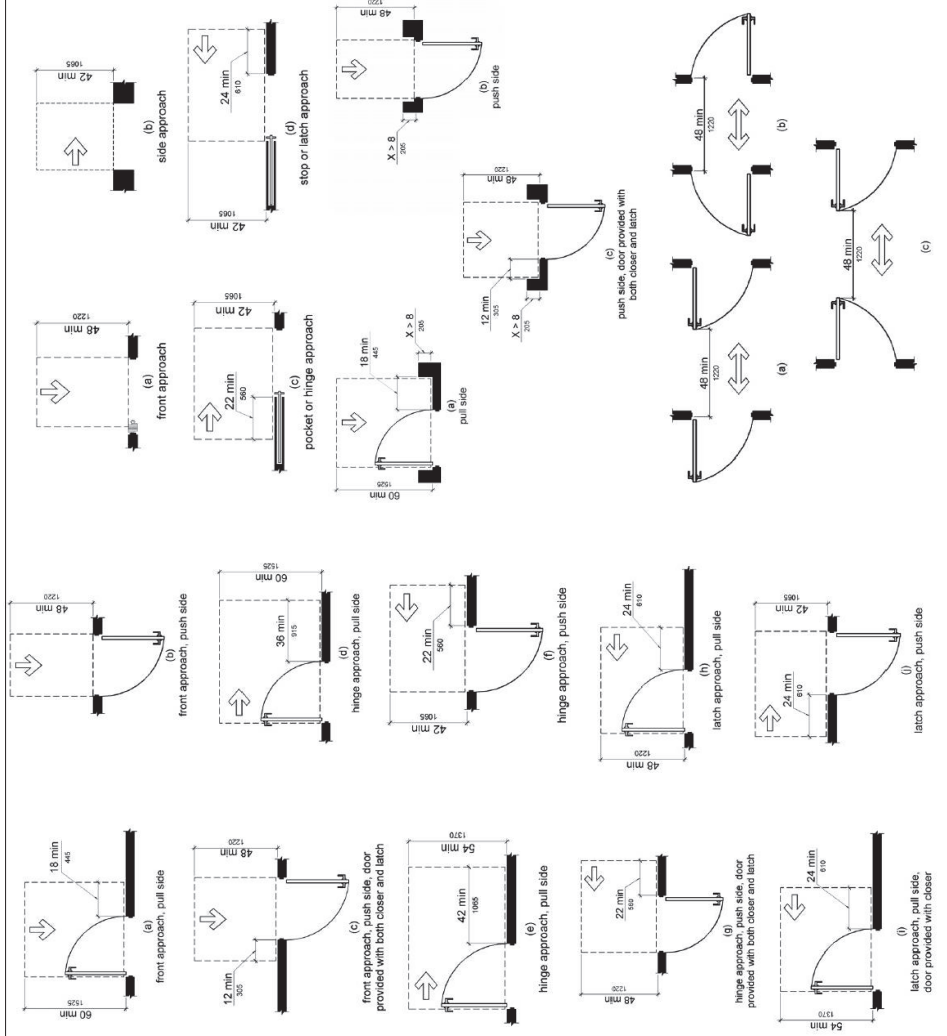

Device Mounting Heights
 1/8" = 1'-0"

Maneuvering Clearances at Doors
 1/8" = 1'-0"

Revision	Revision Date	Issued For

THE SEVERAL LEVELS OF PEACOCK ARCHITECTS, INC. HAS REVIEWED THIS PLAN FOR CONFORMANCE WITH THE CITY OF CHARLOTTE'S LIFE SAFETY CODE. THIS REVIEW IS LIMITED TO THE INFORMATION PROVIDED AND DOES NOT CONSTITUTE A GUARANTEE OF THE ACCURACY OF THE INFORMATION PROVIDED. THE USER OF THIS PLAN SHALL BE RESPONSIBLE FOR OBTAINING ALL NECESSARY PERMITS AND FOR OBTAINING ALL NECESSARY INFORMATION FROM THE CITY OF CHARLOTTE AND THE STATE OF NORTH CAROLINA. THE USER OF THIS PLAN SHALL BE RESPONSIBLE FOR OBTAINING ALL NECESSARY PERMITS AND FOR OBTAINING ALL NECESSARY INFORMATION FROM THE CITY OF CHARLOTTE AND THE STATE OF NORTH CAROLINA.

DATE: 11/02/2016 11:13 AM
DRAWN BY: [Name]
CHECKED BY: [Name]
SCALE: 1/8" = 1'-0"
SHEET NO.: C005

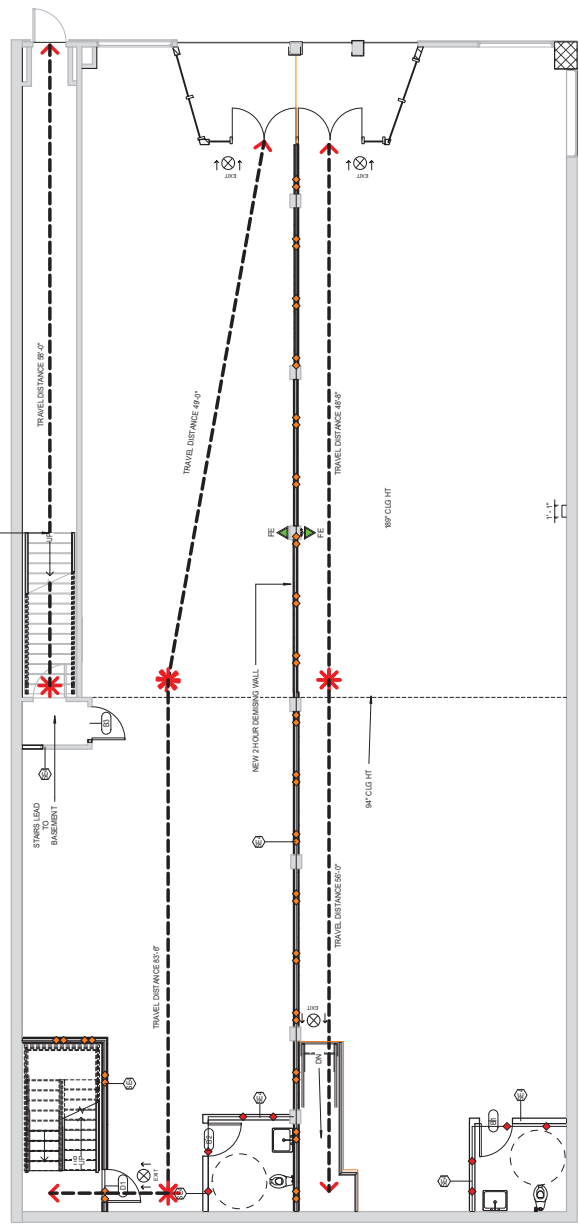

1. LIFE SAFETY PLAN - GROUND FLOOR
 3/16" = 1'-0"

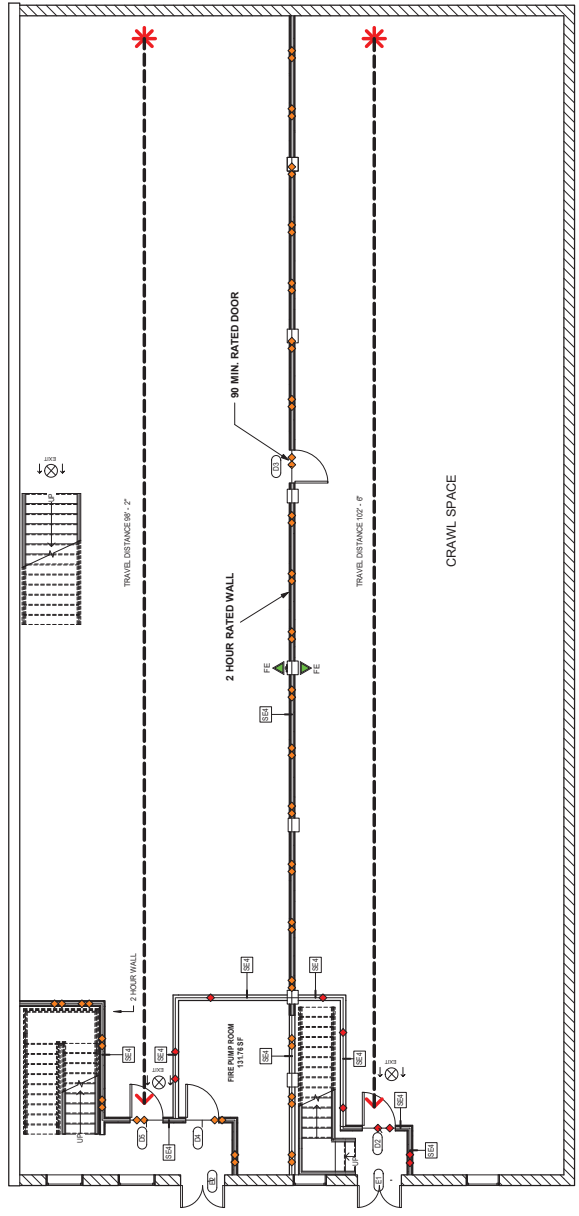

2. LIFE SAFETY PLAN - CRAWL SPACE LEVEL
 3/16" = 1'-0"

- FIRE RATING AND FIRE PROOFING NOTES:**
1. ALL NEW WALLS AND CEILING SHALL BE RATED 2 HOUR NEW.
 2. CEILING TO BE 2 HOUR RATED AS WELL USE SAME U.L. CONSTRUCTION AS WALL RATED BELOW PERPENDICULAR TO EXISTING FLOOR JOISTS.
- LIFE SAFETY LEGEND**
- RATED - 1 HOUR - NEW
 - RATED - 2 HOUR - NEW
 - RATED - 4 HOUR - NEW
 - EGRESS PATH OF TRAVEL
 - DOOR EXIT OCCUPANT LOAD
 - DOOR CLEAR EXIT WIDTH (IN INCHES)
 - 2A RECESSED OR SEMI-RECESSED FIRE EXTINGUISHER CABINET
 - CEILING MOUNTED EXIT SIGN (ARROWS WHEN INDICATED)
 - WALL MOUNTED EXIT SIGN (ARROWS WHEN INDICATED)

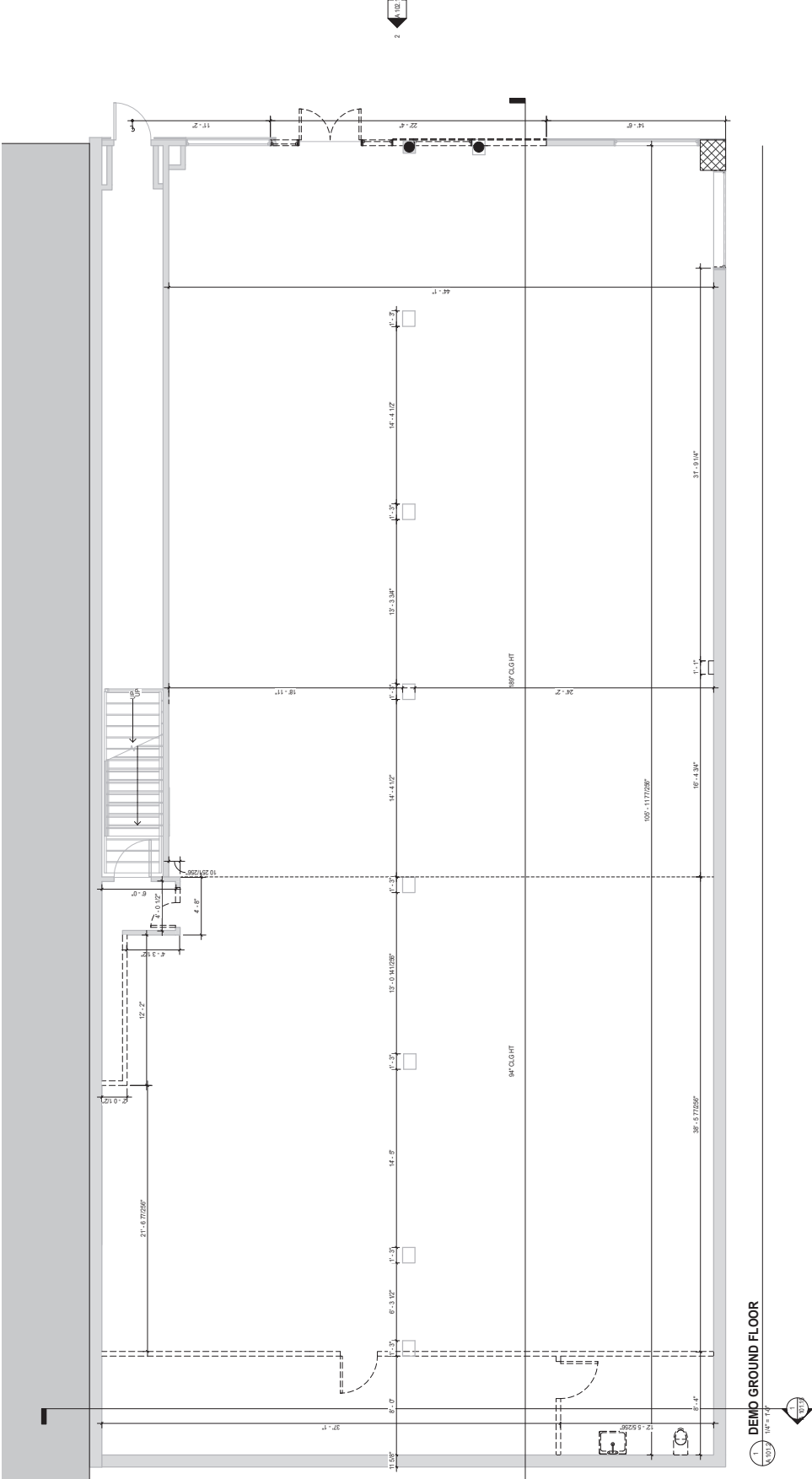

1 DEMO GROUND FLOOR
 1/8" = 1'-0"

Revision	Date	Issued For

The accuracy of this drawing is dependent on the accuracy of the information provided to the architect. The architect is not responsible for errors or omissions in the information provided. The architect is not responsible for the construction of the project.

DATE: 11/08/2016 12:56 PM
 CHECKED: [Signature]
 DRAWN BY: [Signature]
 PROJECT: [Signature]

SHEET NO.: **A 101.3**

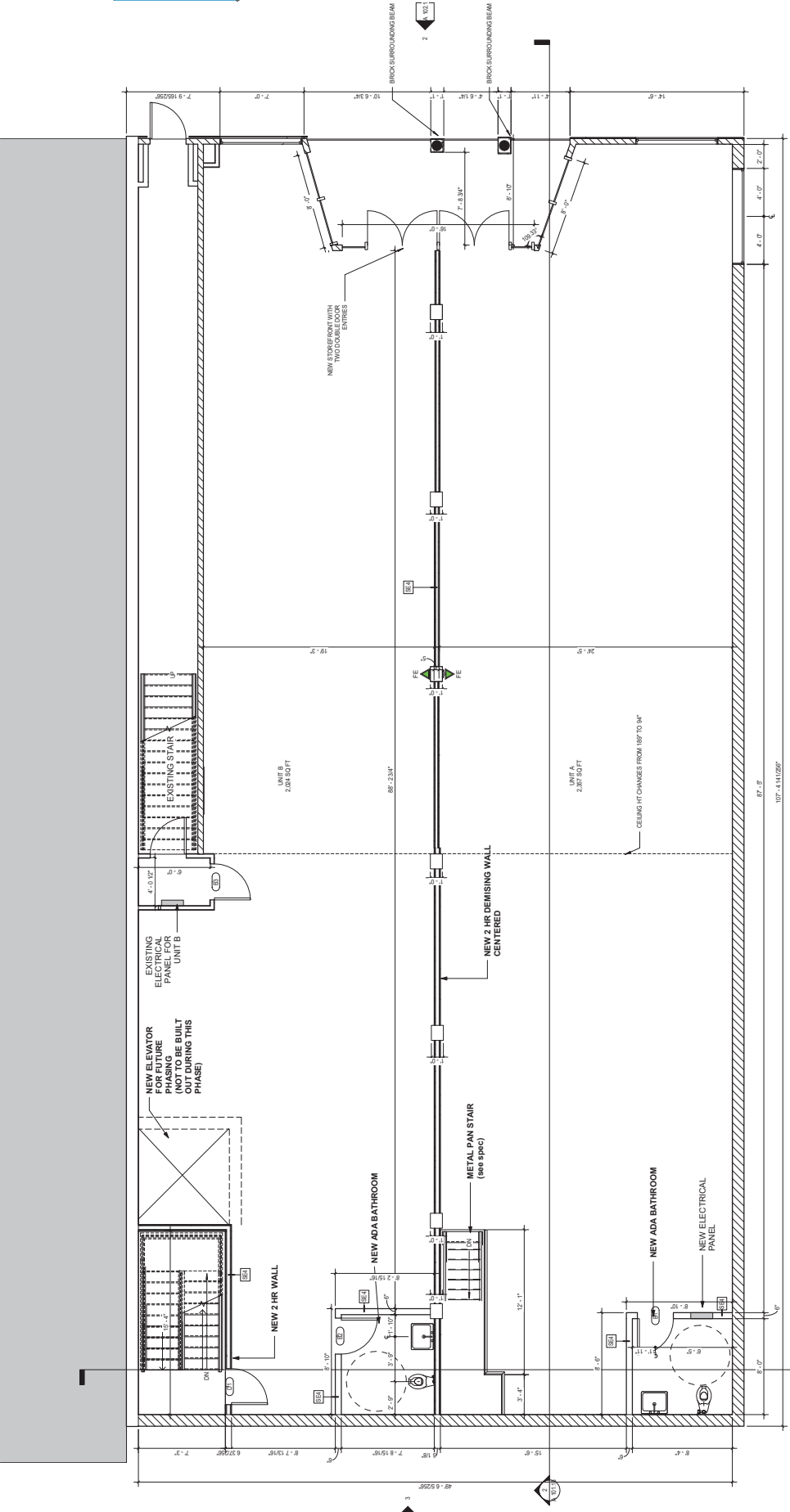

1.1 FIRST FLOOR PLAN - NEW
 1/8" = 1'-0"

UNIT NAME	LEASABLE SQUARE FOOTAGE
UNIT A	237 RS SQ FT
UNIT B	238 RS SQ FT

The accuracy of this drawing is the responsibility of the architect. It is the responsibility of the client to verify the accuracy of the information provided. The architect is not responsible for any errors or omissions on this drawing. The architect is not responsible for any construction methods or materials used in the construction of the project. The architect is not responsible for any conditions or circumstances that may arise during the construction of the project. The architect is not responsible for any conditions or circumstances that may arise during the construction of the project.

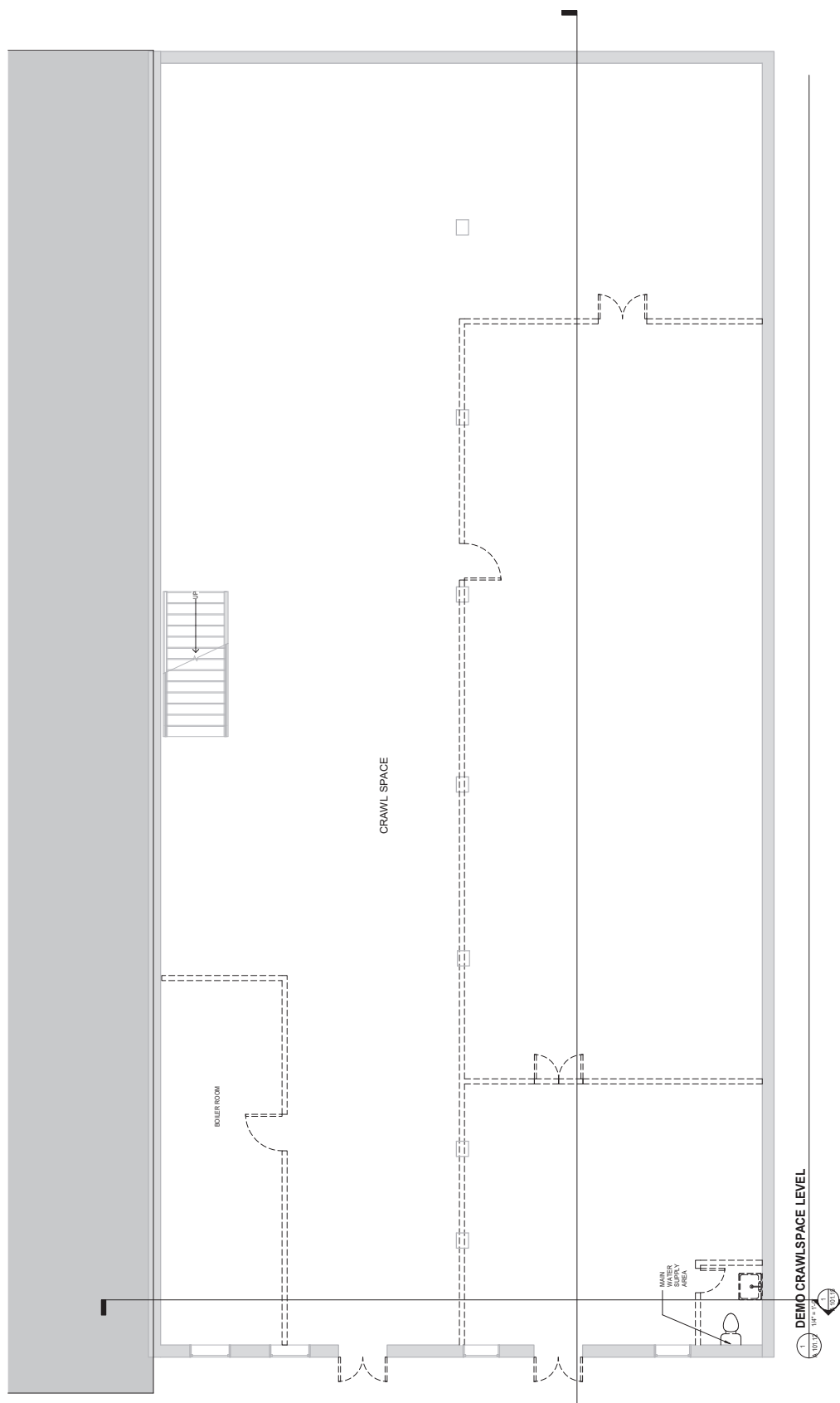

1 DEMO CRAWLSPACE LEVEL
 1/8" = 1'-0"

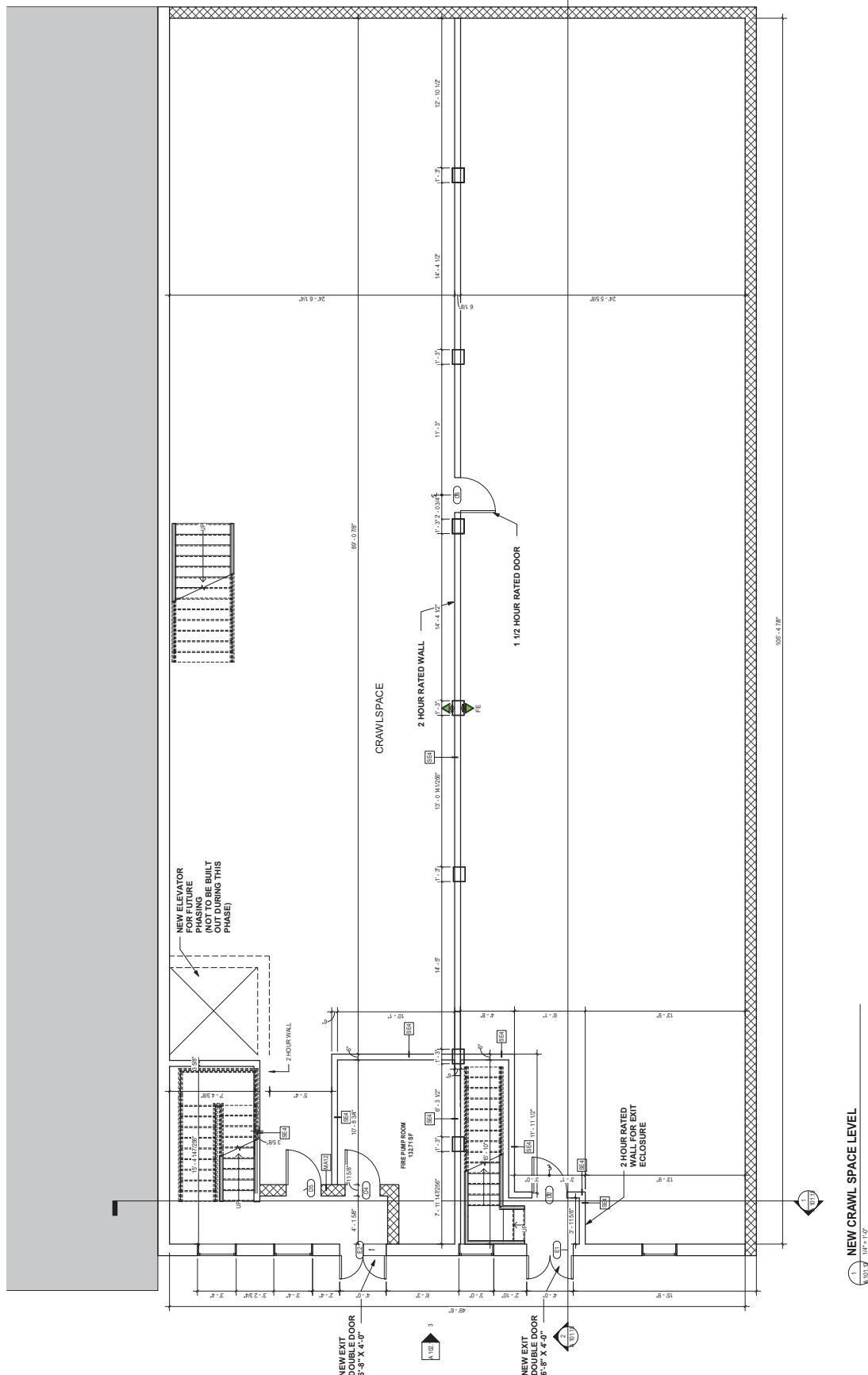

Revision	Revision Date	Issued For

THE ARCHITECT'S LIABILITY IS LIMITED TO THE DESIGN OF THE BUILDING AS SHOWN ON THESE PLANS. THE ARCHITECT DOES NOT WARRANT THE ACCURACY OF ANY INFORMATION PROVIDED BY OTHERS. THE ARCHITECT'S LIABILITY IS LIMITED TO THE DESIGN OF THE BUILDING AS SHOWN ON THESE PLANS. THE ARCHITECT DOES NOT WARRANT THE ACCURACY OF ANY INFORMATION PROVIDED BY OTHERS.

DATE: 11/20/2025 11:58:37 AM
 CHECKED BY: [Name]
 DRAWN BY: [Name]
 SCALE: 1/8" = 1'-0"

SHEET NO.: A 102

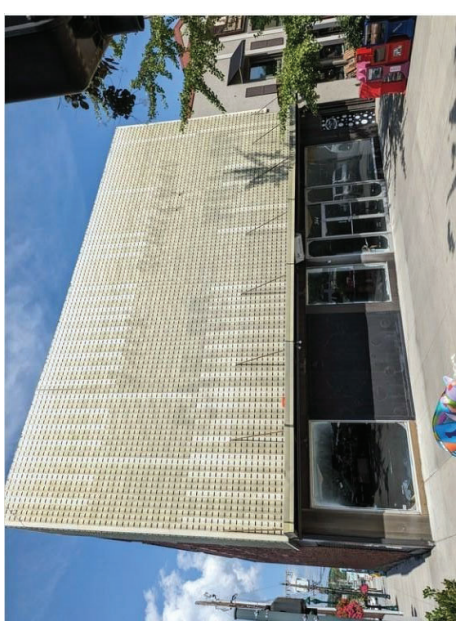
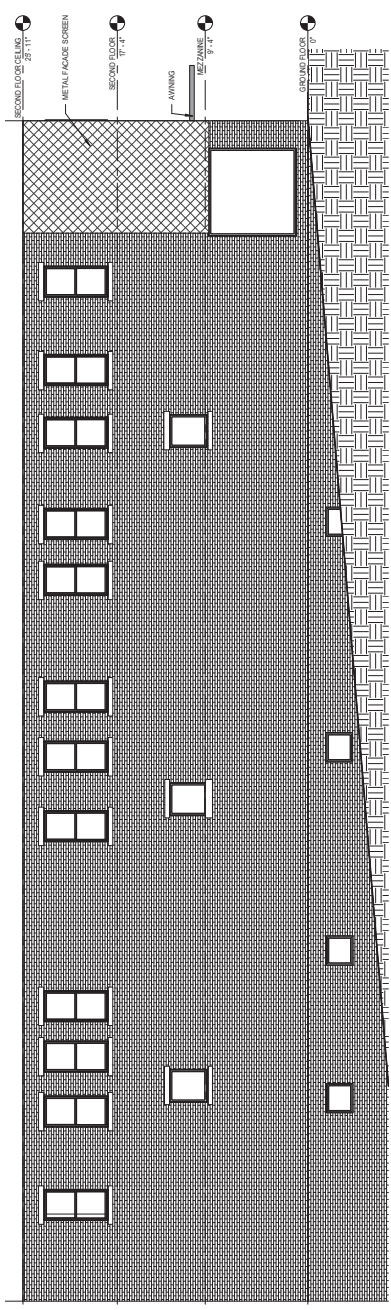
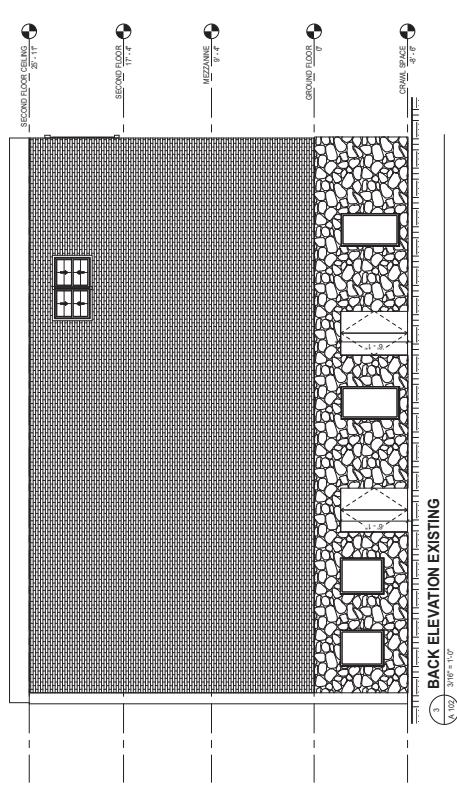
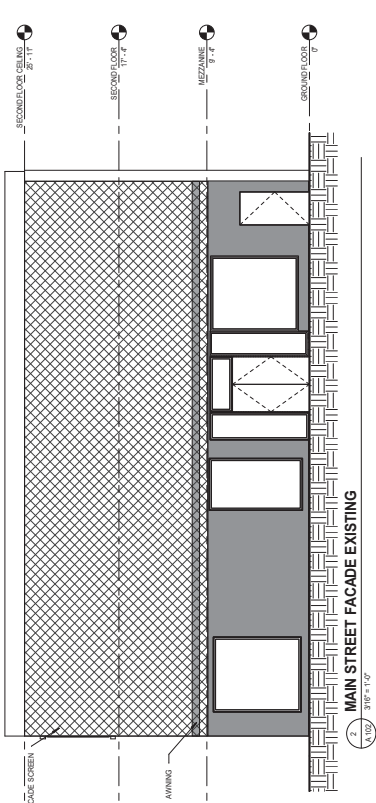

EXISTING PHOTO OF 34 MAIN STREET VIEW



EXISTING PHOTO OF 34 MAIN STREET BACK ALLEY VIEW

WEST ELEVATION EXISTING
 3/8" = 1'-0"

Revision	Date	Issued For

The information on this drawing is the property of Peacock Architects, Inc. and is to be used only for the project and site specifically identified on this drawing. No other use, reproduction, or distribution of this information is permitted without the written consent of Peacock Architects, Inc. The information on this drawing is not to be used for any other project, site, or purpose. The information on this drawing is not to be used for any other project, site, or purpose. The information on this drawing is not to be used for any other project, site, or purpose.

DATE: 11/20/2025 11:39:02 AM
CHECKED BY: [Blank]
DATE: [Blank]
SCALE: [Blank]
BY: [Blank]
DATE: [Blank]

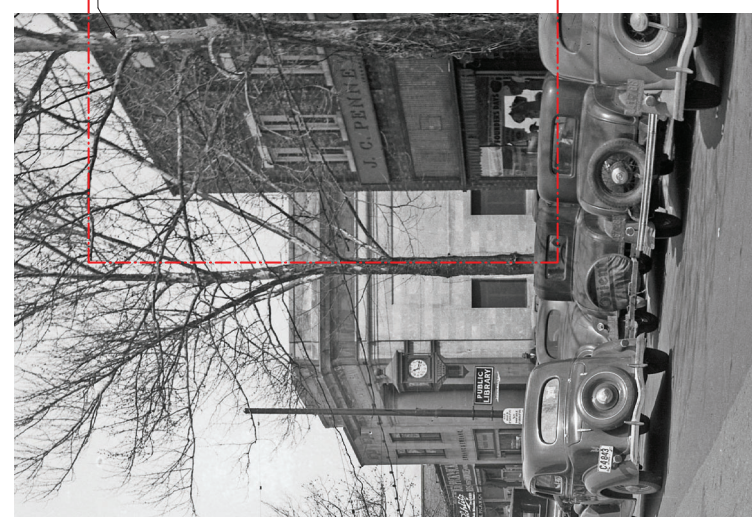

344 MAIN ORIGINAL FACADE

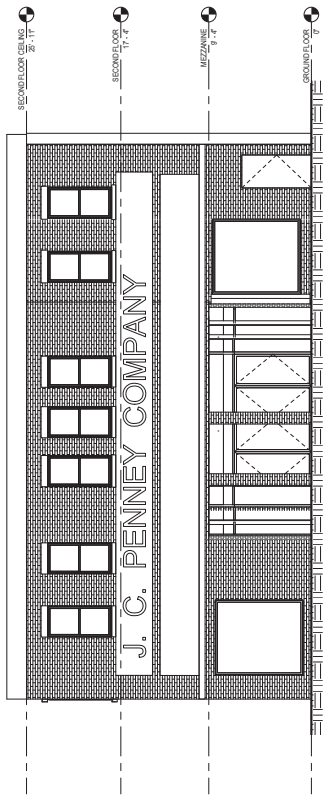

2 MAIN STREET FACADE NEW

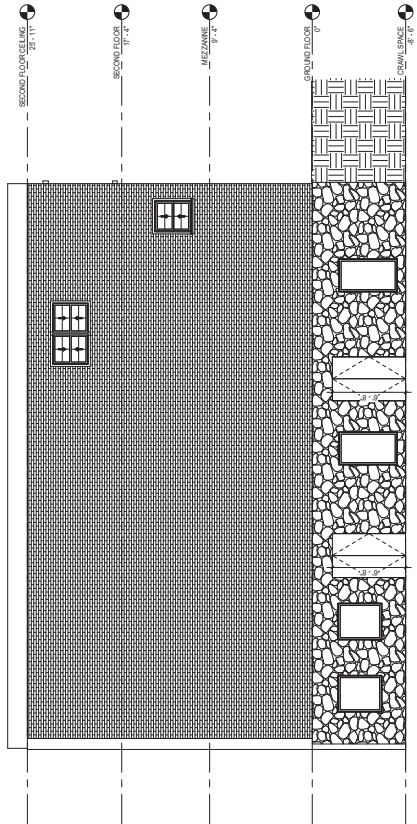

3 BACK ELEVATION NEW

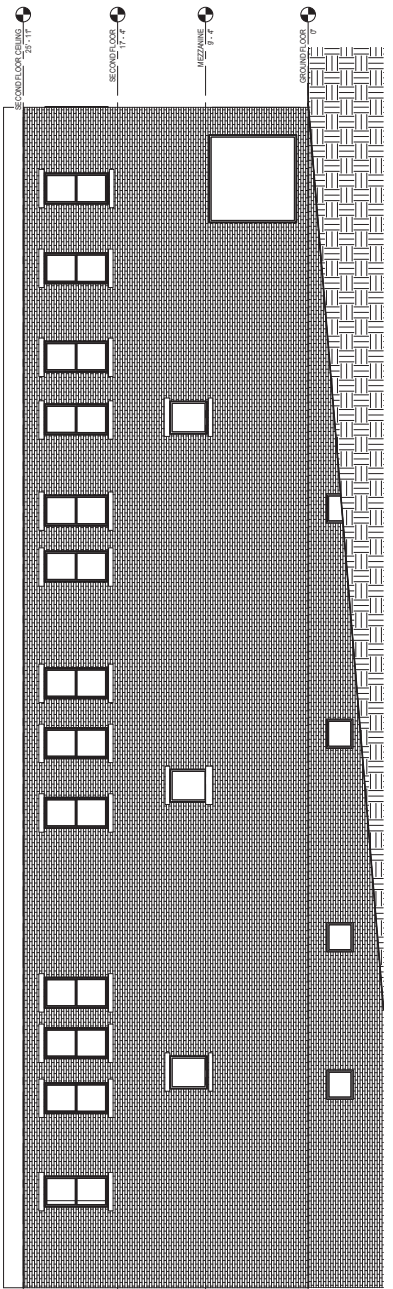

4 NORTH ELEVATION NEW

344 MAIN FACADE RESTORATION
 100 WEST MAIN STREET
 BARBER COLLECTION HENDERSON
 COUNTY PUBLIC LIBRARY

The accuracy of the information provided herein is the responsibility of the user. The user shall verify the accuracy of the information provided herein. The user shall not rely on the information provided herein for any purpose other than that intended. The user shall not use the information provided herein for any purpose other than that intended. The user shall not use the information provided herein for any purpose other than that intended.

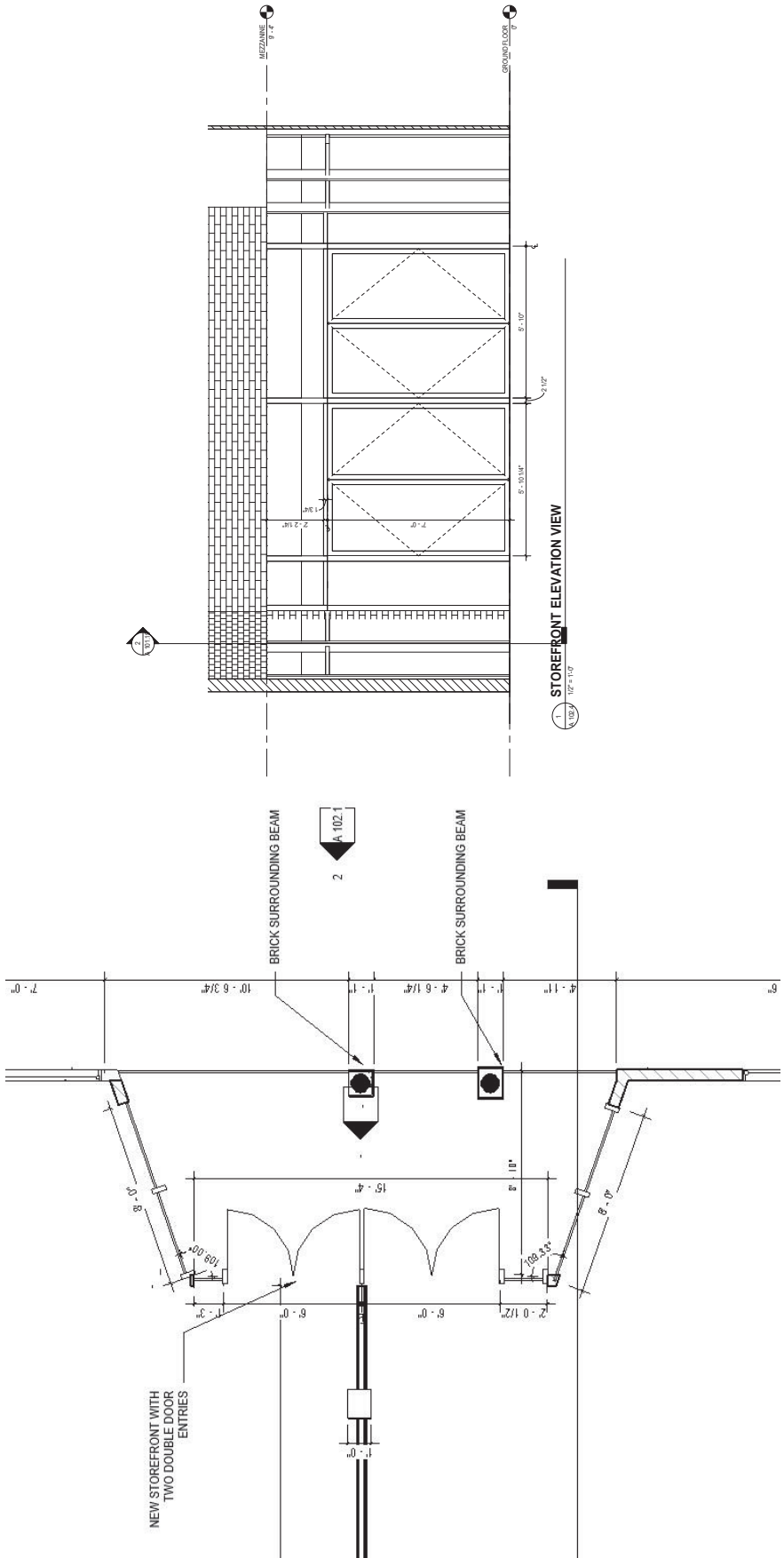

FLOOR PLAN VIEW OF STOREFRONT

The accuracy of the information provided herein is the responsibility of the client. The architect is not responsible for the accuracy of the information provided by the client. The architect is not responsible for the accuracy of the information provided by the client. The architect is not responsible for the accuracy of the information provided by the client.

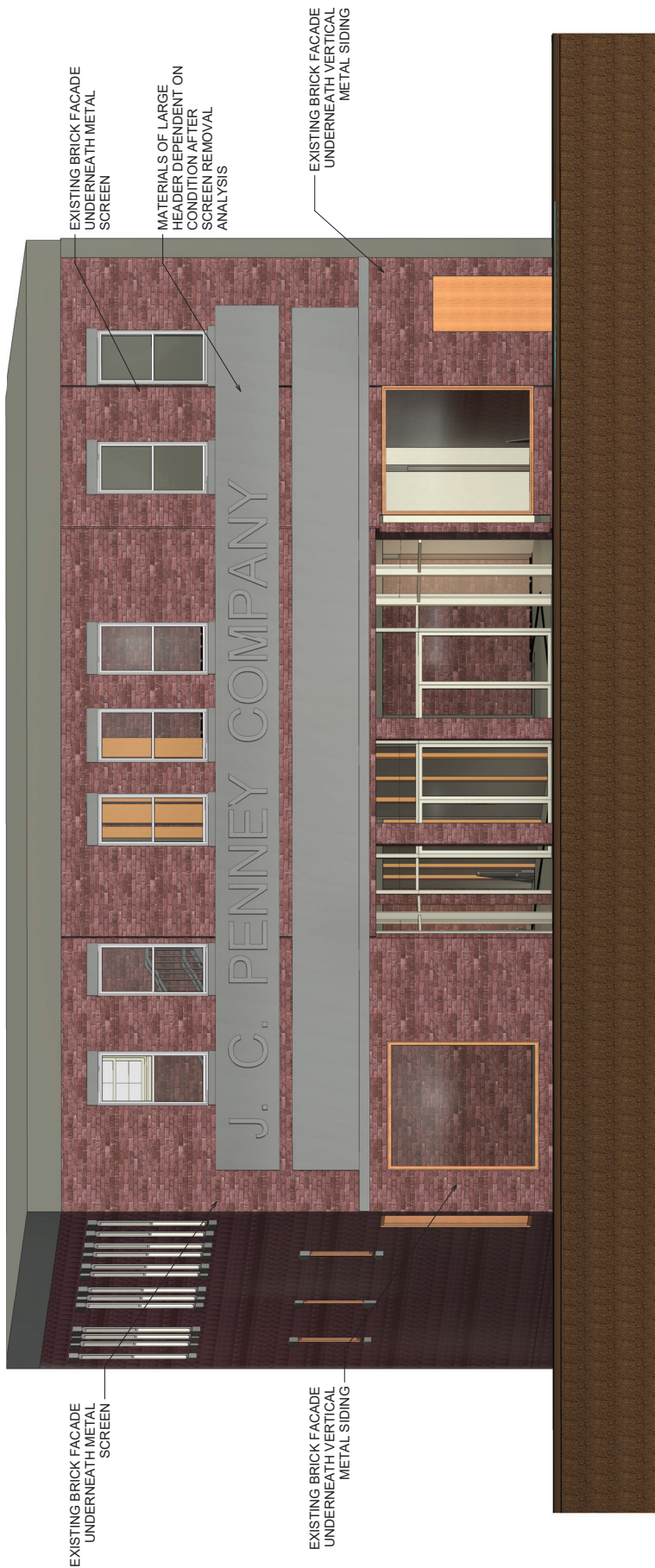

STREET VIEW Copy 1



YKK ap[®]

www.ykkap.com

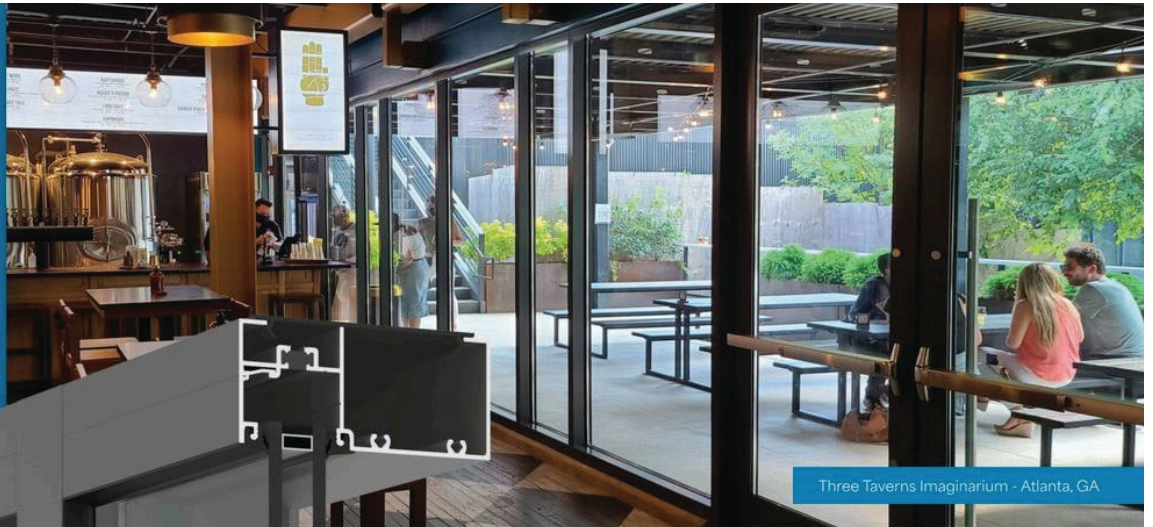

Three Taverns Imaginarium - Atlanta, GA

YES 45 TU Front

Thermally Broken and Front Set Storefront System

The **YES 45 TU Front** was designed for excellent thermal performance with standard Low-E insulating glass. Hinged mullions coupled with 90° or 135° inside/outside corners allow creative freedom when curves and angles are part of the design. The glass is set to the front to maximize energy performance and blend with the aesthetics of a curtain wall.

- Outside, Inside and SSG Glazing options
- ThermaBond Plus[®] pour and de-bridged break for better thermal performance
- High Performance Sill Flashing
 - ◆ No blind seals
 - ◆ Tall back leg for enhanced water resistance
 - ◆ Patented 3-point attachment of end dam
- Stick built assembly with concealed fasteners by Screw Spline or Shear Block
- Integrates with our YKK AP Entrances and Sun Control Systems

Configuration:

Glazing	Glass Setting	Installation
Outside, Inside and SSG	Front Set	Screw Spline or Shear Block

Thermal Values:

U-Factor:	Values as low as 0.32*
CRF:	Minimum 68 _{frame} and 64 _{glass}

*Based on AAMA 507. Lower values may be achieved through further simulation.



YES 45 TU FRONT SET OUTSIDE GLAZED SCREW SPLINE ASSEMBLY

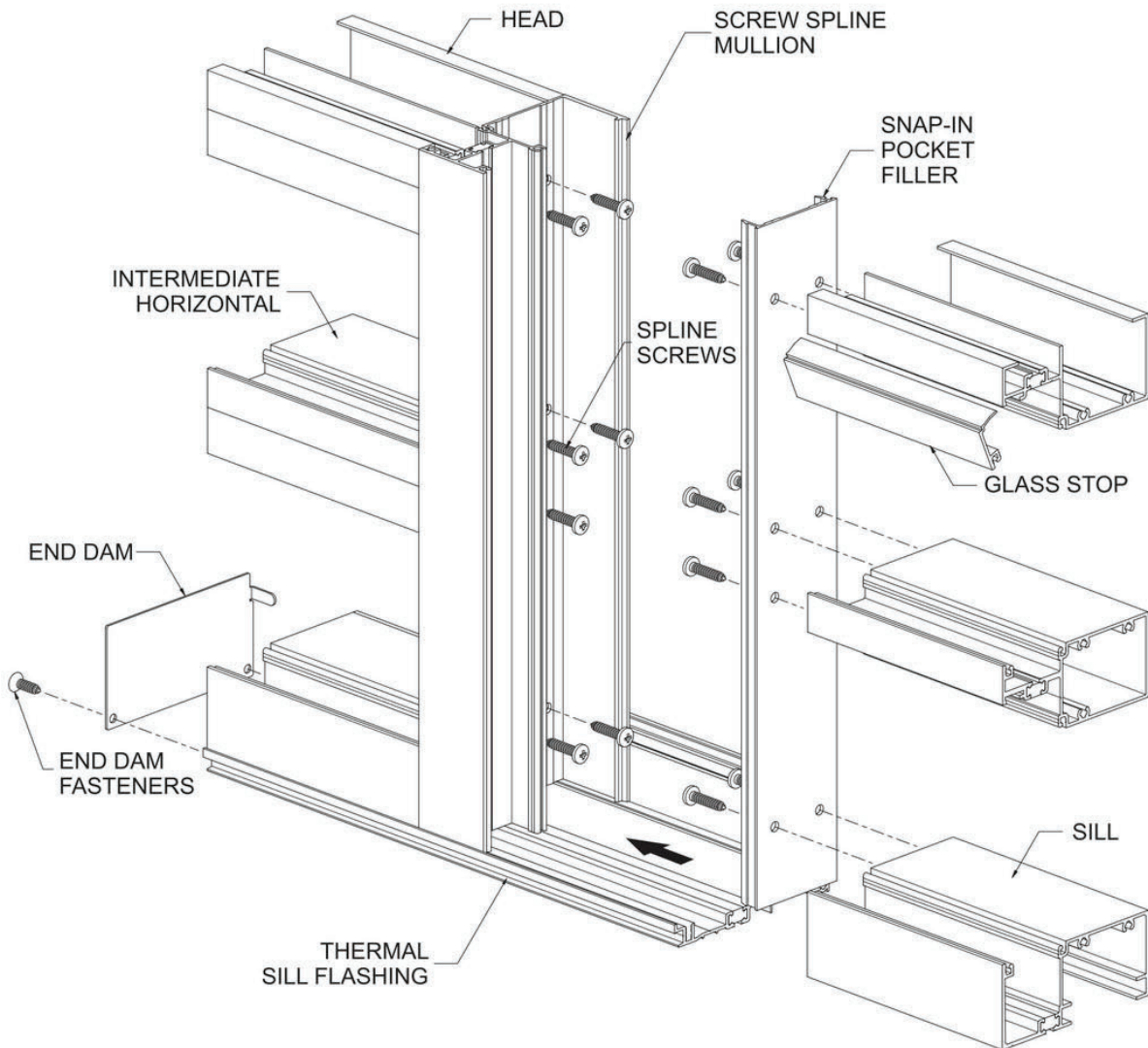

YES 45 TU FRONT SET OUTSIDE GLAZED SHEAR BLOCK ASSEMBLY

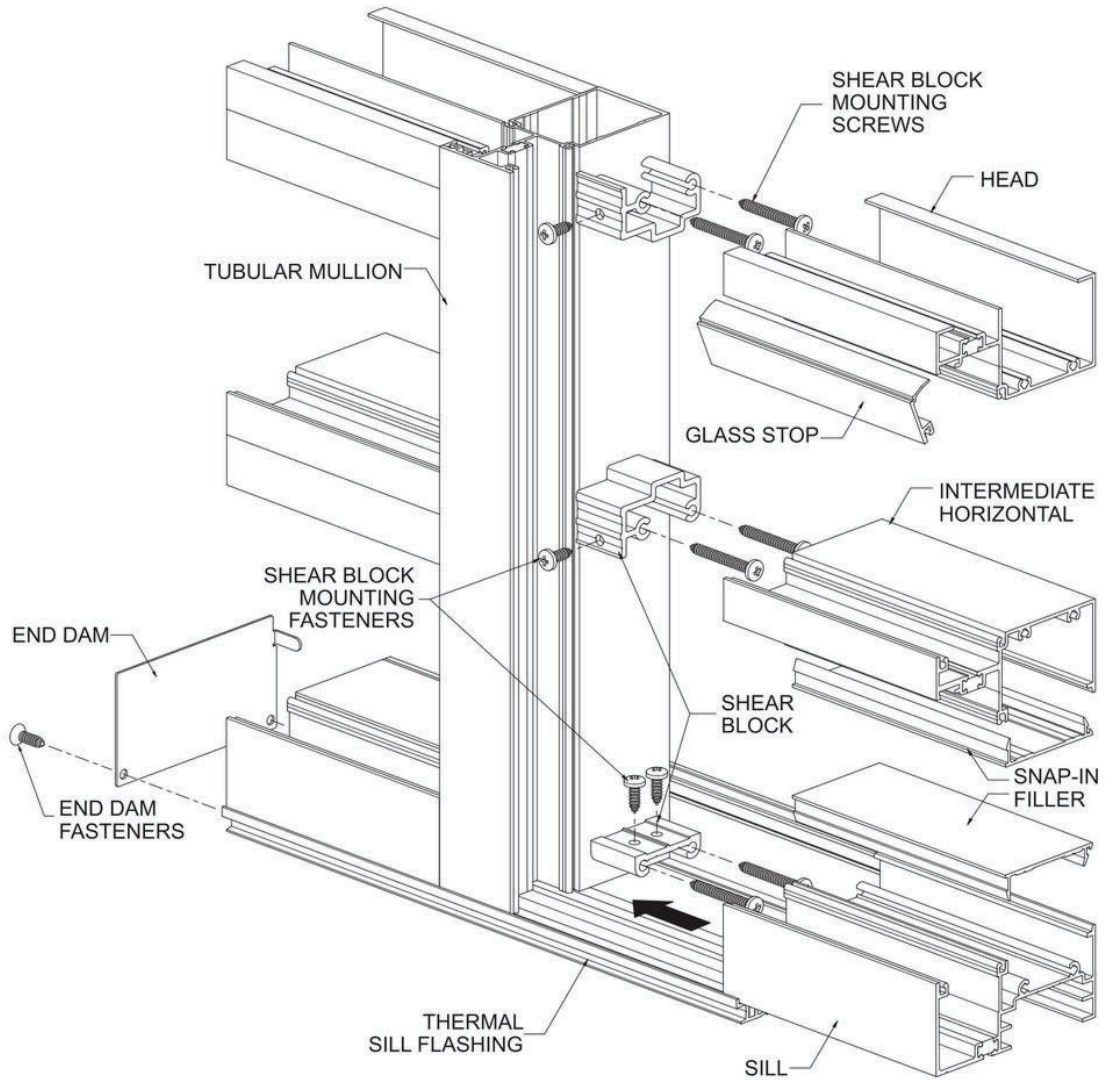

YES 45 TU FRONT SET INSIDE GLAZED SCREW SPLINE ASSEMBLY

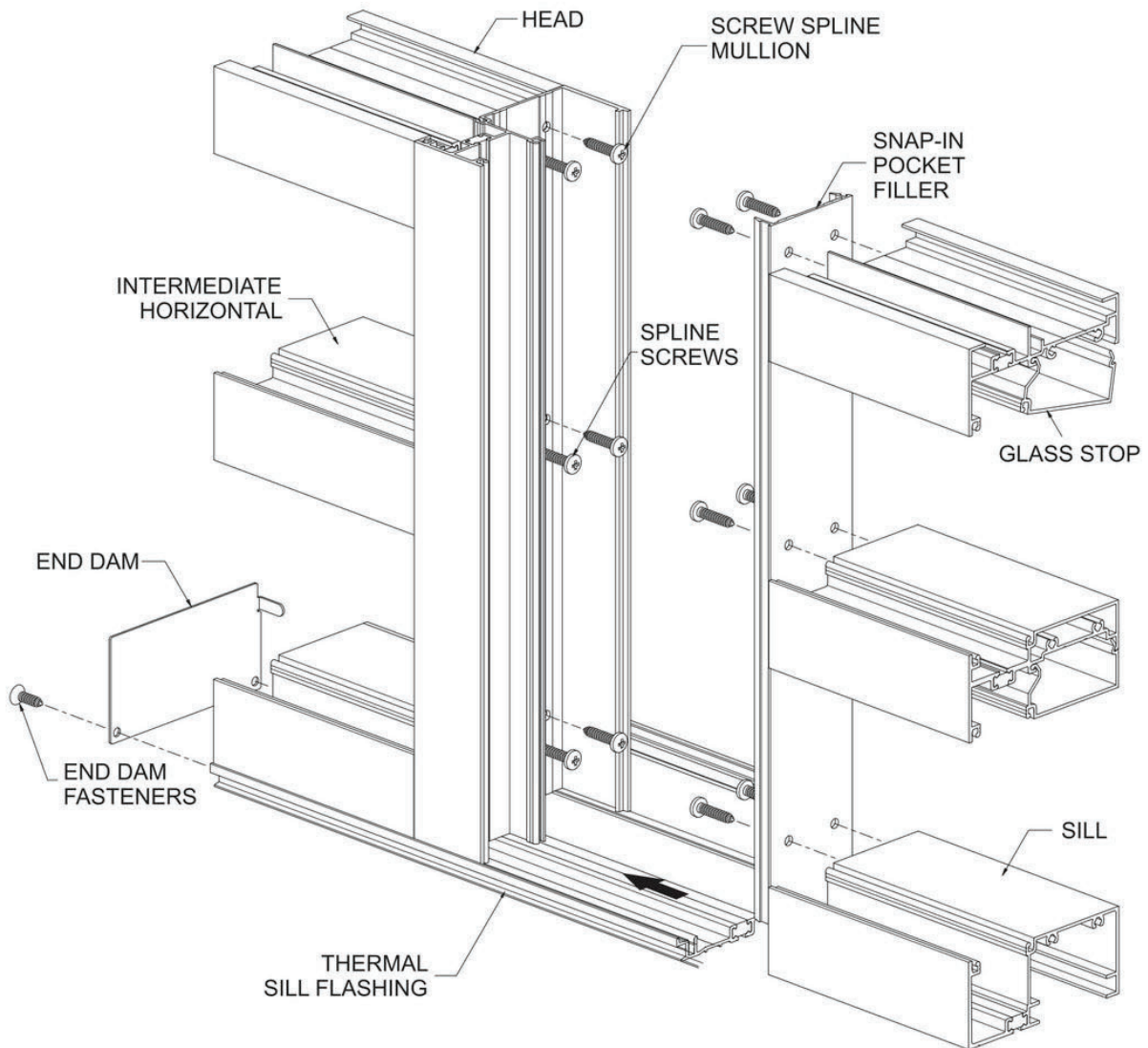

YES 45 TU FRONT SET INSIDE GLAZED SHEAR BLOCK ASSEMBLY

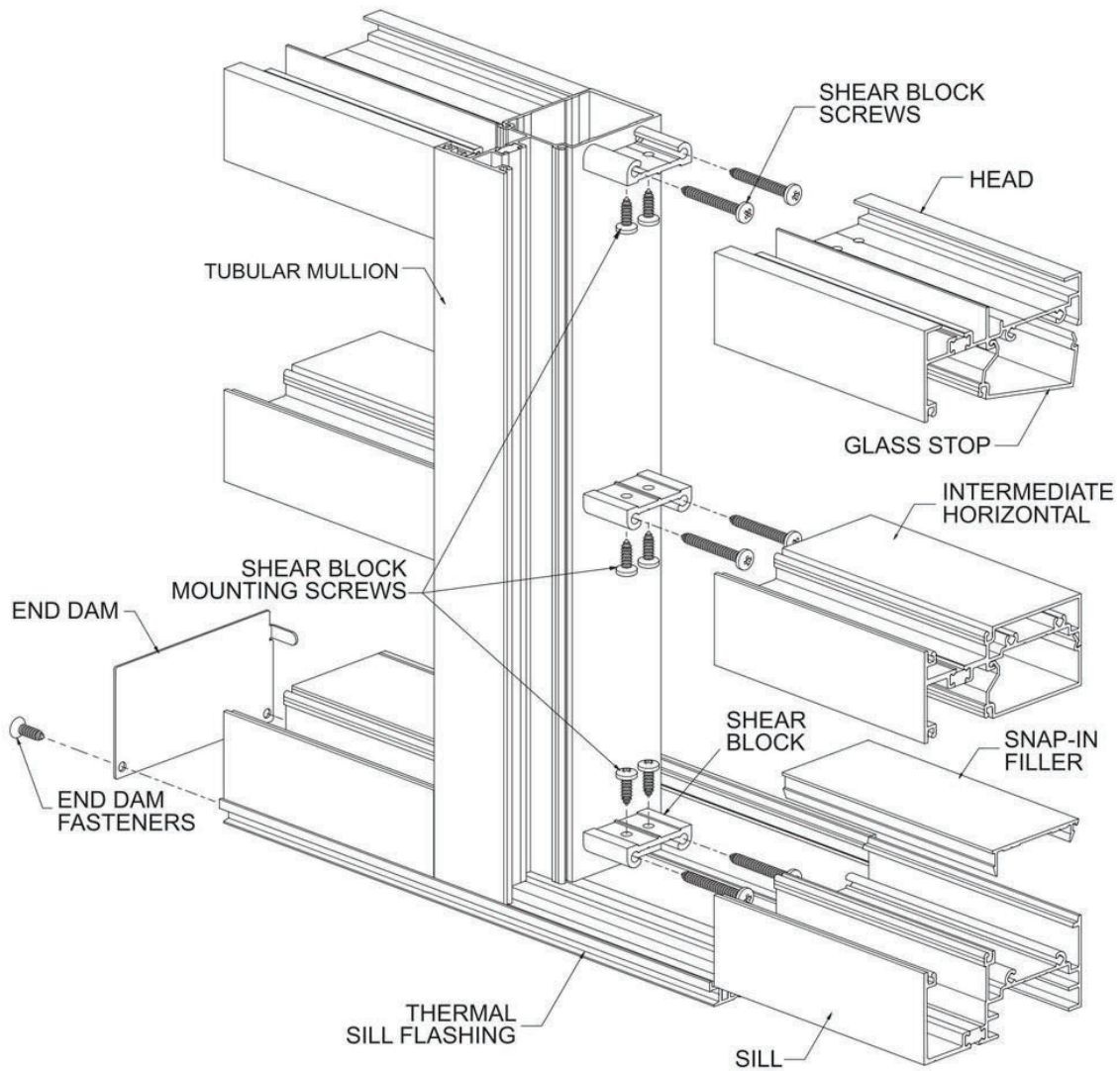

YES 45 TU FRONT SET SSG ASSEMBLY

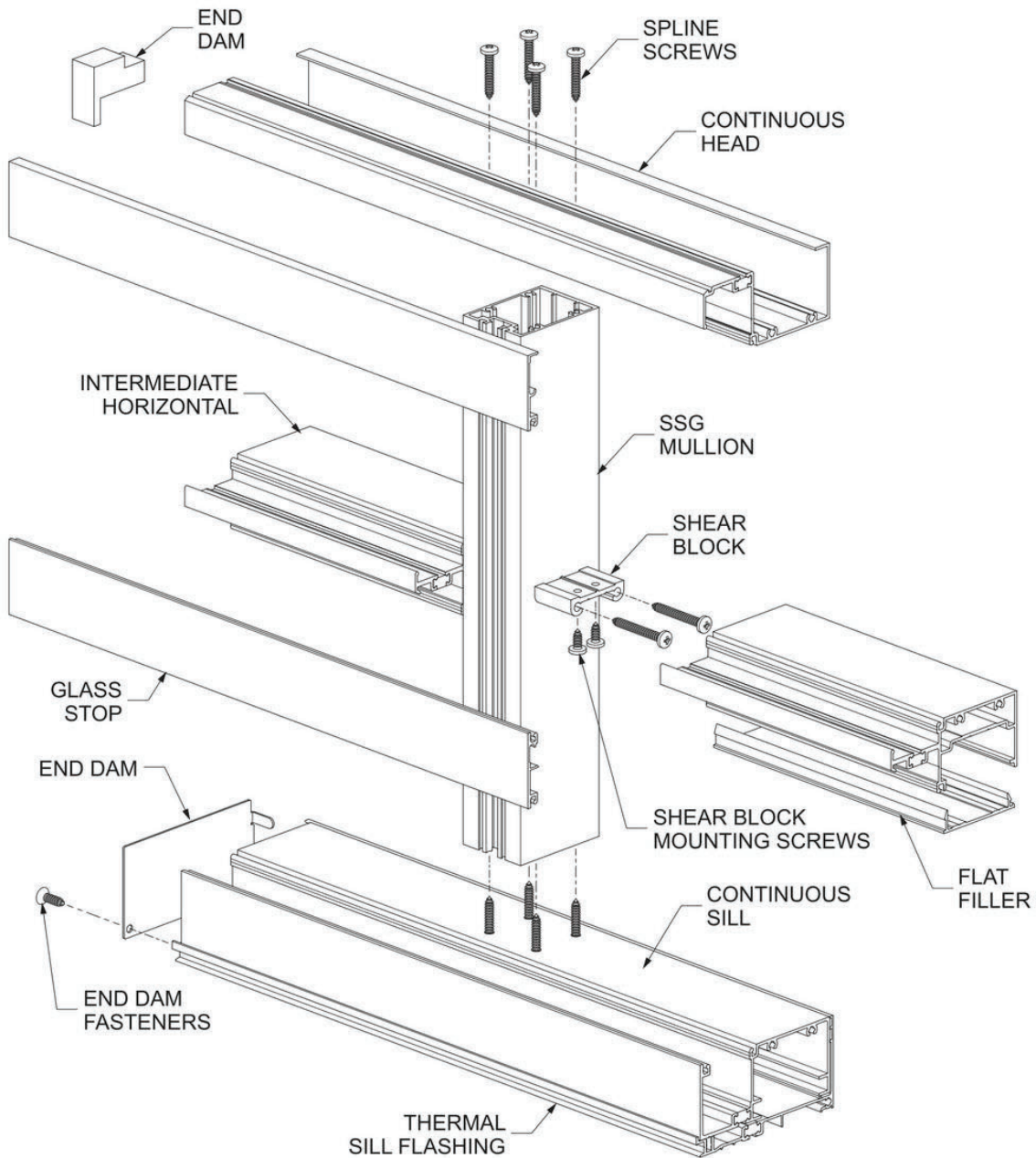

YES 45 TU FRONT SET HORIZONTAL MEMBERS FOR OUTSIDE GLAZING

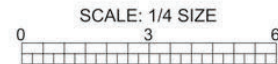
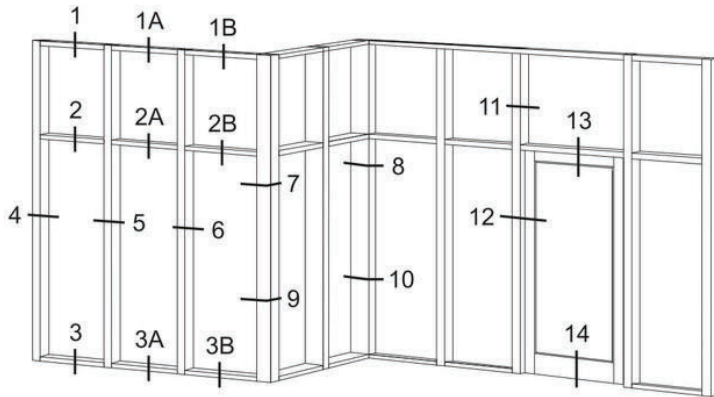

SCREW SPLINE

SHEAR BLOCK

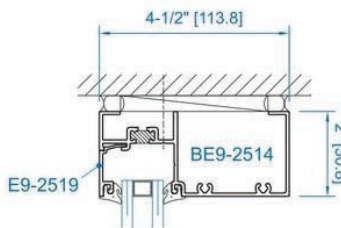

SECTION 1
HEAD

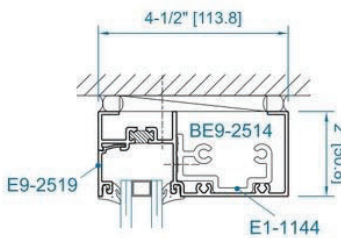

SECTION 1A
HEAD

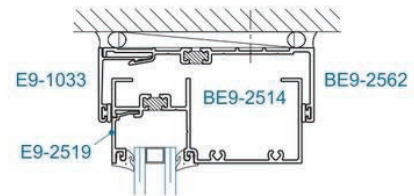

SECTION 1B
HEAD RECEPTOR

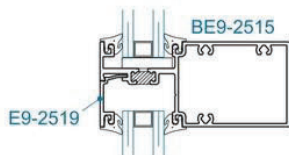

SECTION 2
HORIZONTAL

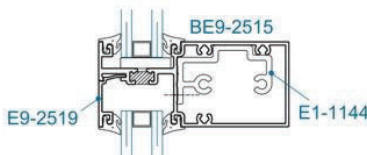

SECTION 2A
HORIZONTAL

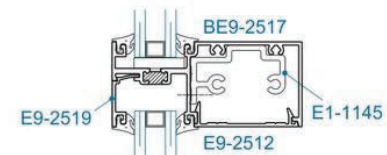

SECTION 2B
HORIZONTAL
END BAY CONDITION

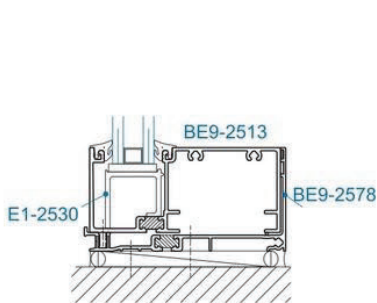

SECTION 3
SILL

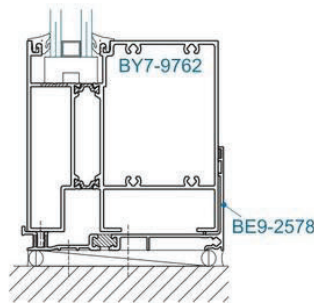

SECTION 3A
4-1/2" SILL

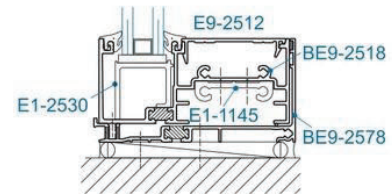

SECTION 3B
SILL

YES 45 TU FRONT SET HORIZONTAL MEMBERS FOR INSIDE GLAZING

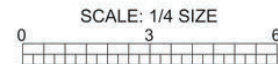
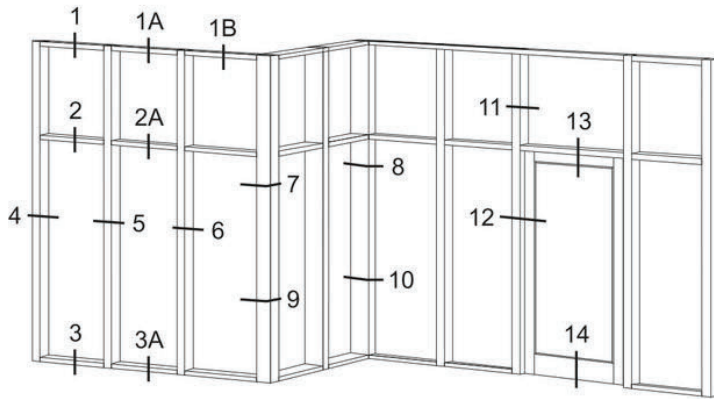

SCREW SPLINE

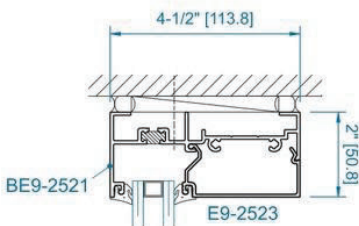

SECTION 1 HEAD

SHEAR BLOCK

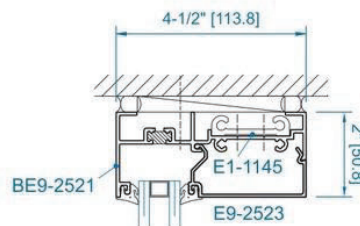

SECTION 1A HEAD

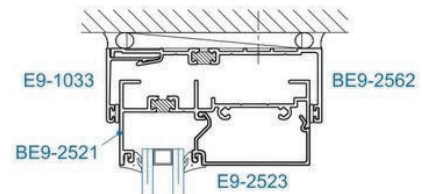

SECTION 1B HEAD RECEPTOR

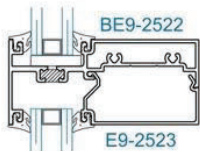

SECTION 2 HORIZONTAL

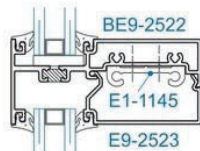

SECTION 2A HORIZONTAL

GLAZING OPTIONS

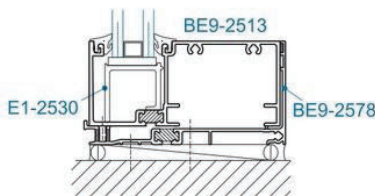
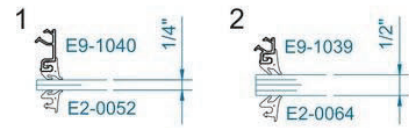

SECTION 3 SILL

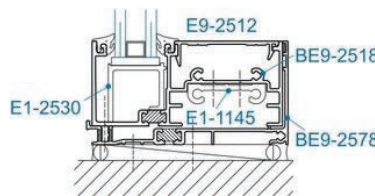

SECTION 3A SILL

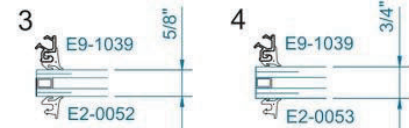

YES 45 TU FRONT SET VERTICAL & CORNER MEMBERS

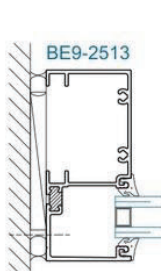
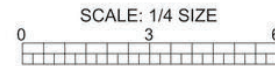
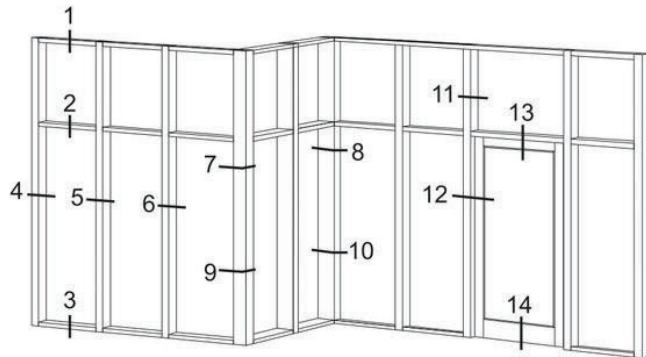

SECTION 4
JAMB

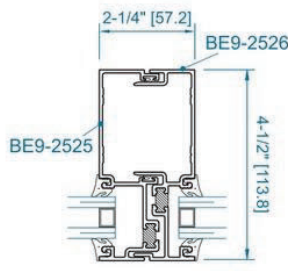

SECTION 6
EXPANSION
MULLION

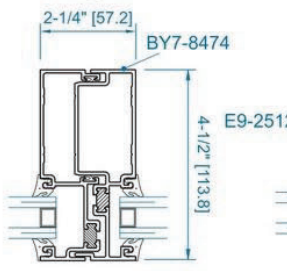

SECTION 6A
TUBULAR EXPANSION
MULLION

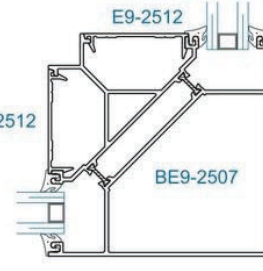

SECTION 7
90° OUTSIDE CORNER

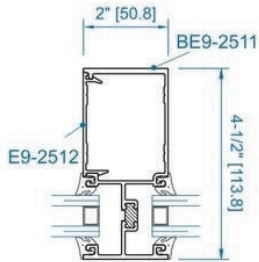

SECTION 5
TWO PIECE MULLION

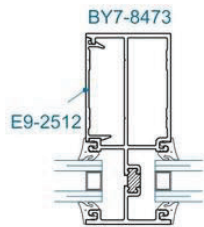

SECTION 5A
ONE PIECE MULLION

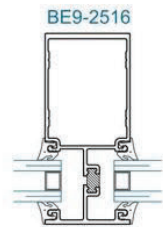

SECTION 5B
ONE PIECE MULLION

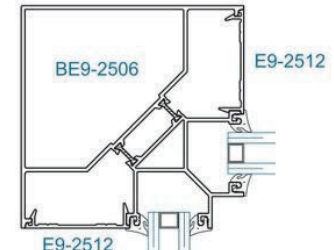

SECTION 8
90° INSIDE CORNER

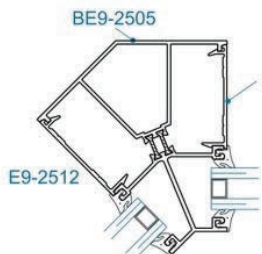

SECTION 9
135° INSIDE CORNER

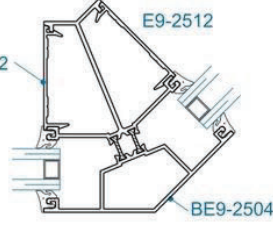

SECTION 10
135° OUTSIDE CORNER



SECTION 9A
0°- 12.5° HINGED
INSIDE CORNER



SECTION 10A
3°- 15° HINGED
OUTSIDE CORNER

YES 45 TU FRONT SET DOOR FRAMING MEMBERS

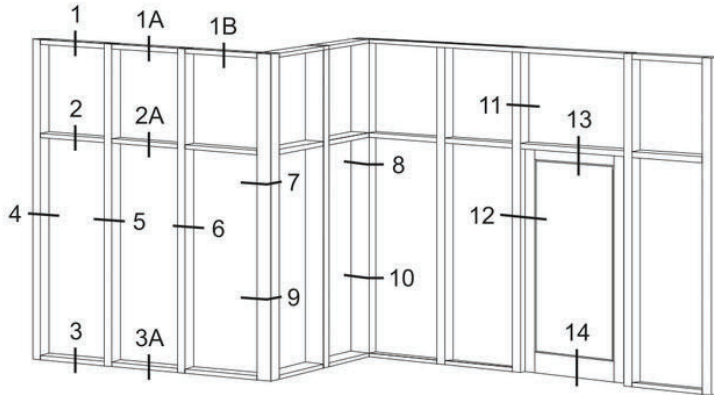

NOTE: For best thermal performance, surface mounted closer is recommended.
Dual Finish option not available with OHCC.

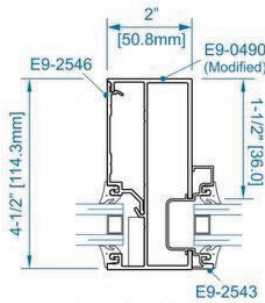
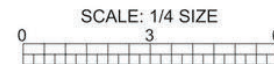

SECTION 11
STANDARD
TRANSOM JAMB

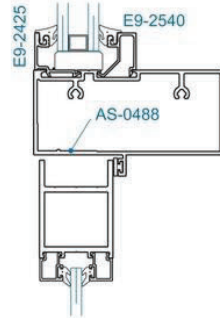

SECTION 13
STANDARD
TRANSOM BAR

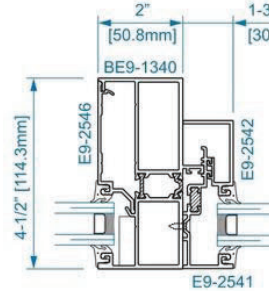

SECTION 11T
THERMAL
TRANSOM JAMB

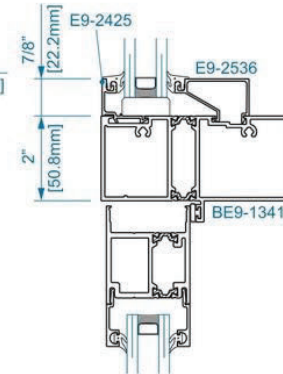

SECTION 13T
THERMAL
TRANSOM BAR

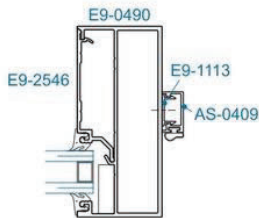

SECTION 12
STANDARD
DOOR JAMB

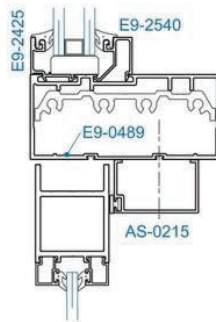

SECTION 13A
OHCC
TRANSOM BAR

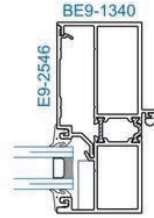

SECTION 12T
THERMAL
DOOR JAMB

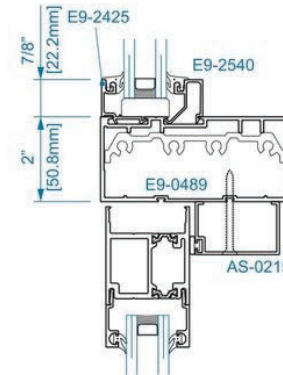

SECTION 13AT
OHCC
TRANSOM BAR

YES 45 TU FRONT SET HORIZONTAL MEMBERS FOR SSG

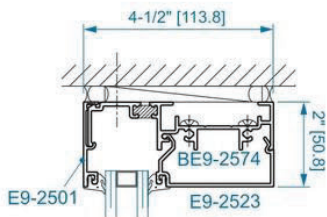
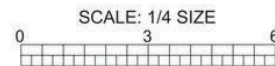
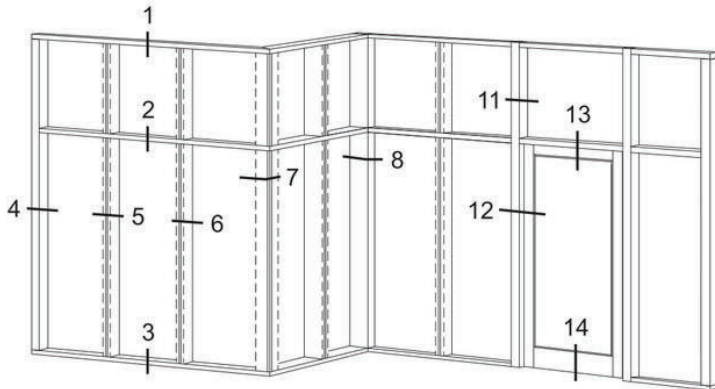

SECTION 1
I.G. HEAD

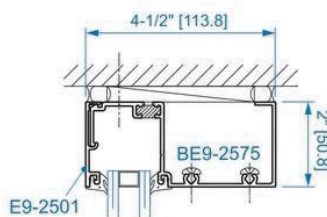

SECTION 1A
O.G. HEAD

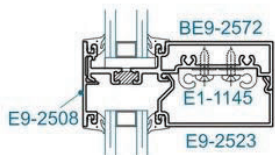

SECTION 2
I.G. HORIZONTAL

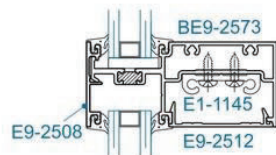

SECTION 2A
O.G. HORIZONTAL

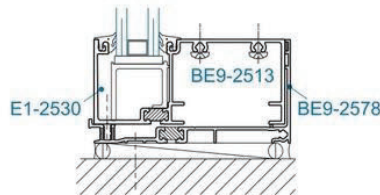

SECTION 3
I.G./O.G. SILL

YES 45 TU FRONT SET VERTICAL MEMBERS FOR SSG

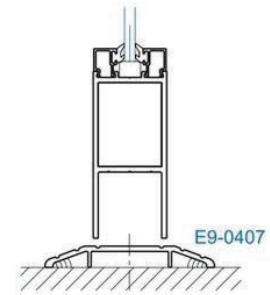
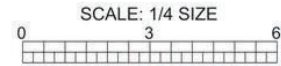
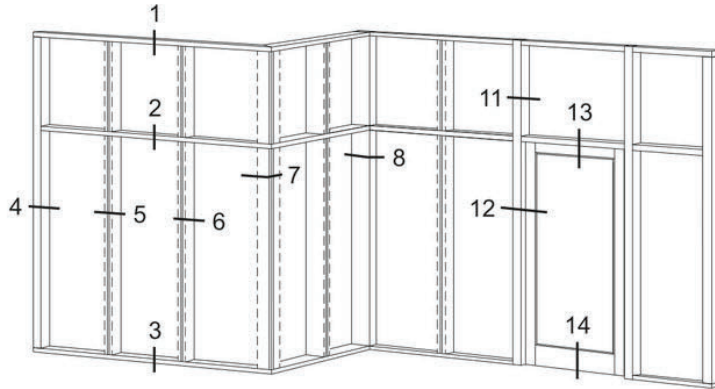

**SECTION 14
BOTTOM RAIL**

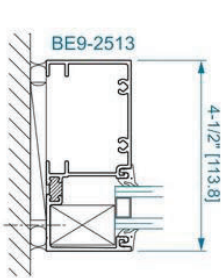

**SECTION 4
JAMB**

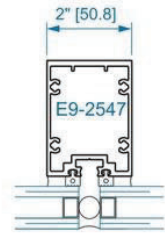

**SECTION 5
SSG MULLION**

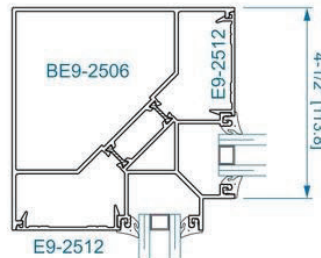

**SECTION 8
90° INSIDE CORNER**

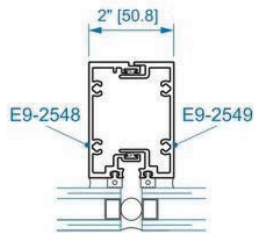

**SECTION 6
EXPANSION
SSG MULLION**

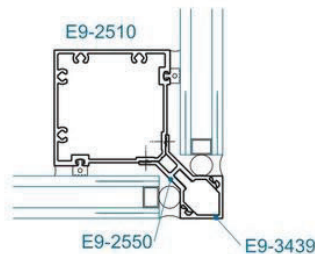

**SECTION 7
SSG CORNER
MULLION**

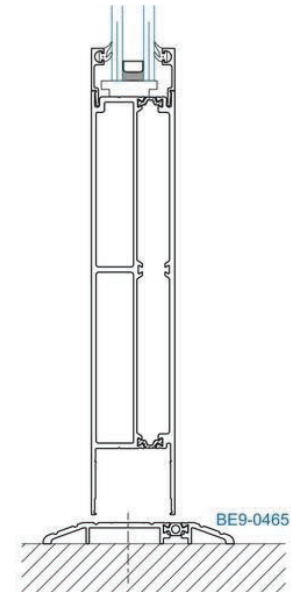

**SECTION 14T
THERMAL BOTTOM
RAIL**

YES 45 TU FRONT SET DOOR FRAMING MEMBERS FOR SSG

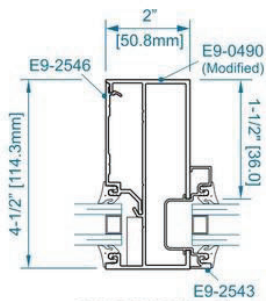
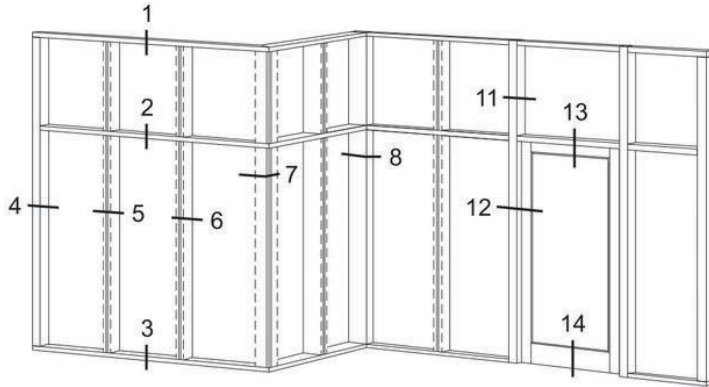

SECTION 11
STANDARD
TRANSOM JAMB

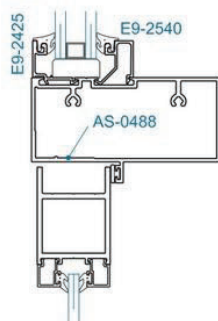

SECTION 13
STANDARD
TRANSOM BAR

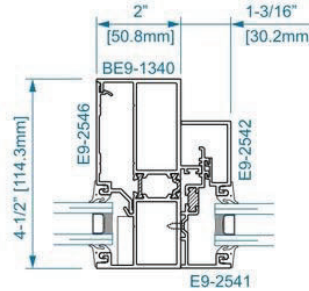

SECTION 11T
THERMAL
TRANSOM JAMB

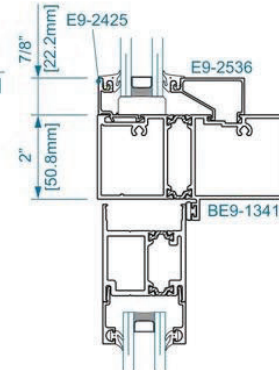

SECTION 13T
THERMAL
TRANSOM BAR

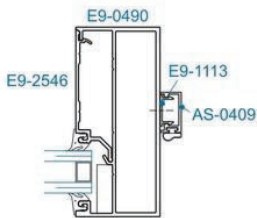

SECTION 12
STANDARD
DOOR JAMB

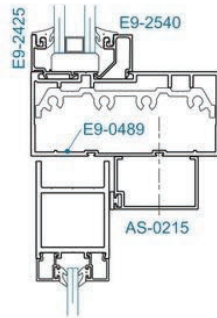

SECTION 13A
OHCC
TRANSOM BAR

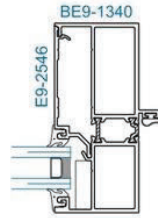

SECTION 12T
THERMAL
DOOR JAMB

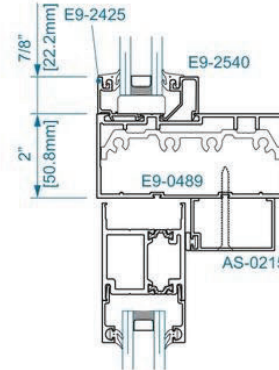

SECTION 13AT
OHCC
TRANSOM BAR

YES 45 TU FRONT SET WIND LOAD CHARTS

DEFLECTION CRITERIA: AAMA TIR-A11 - L/175 FOR $\leq 13'-6"$ SPAN OR
 $L/240 + 1/4"$ (6.4mm) - FOR SPANS GREATER THAN 13'-6" (4.1m) BUT LESS THAN 40'-0" (12.2m)
 CODES AND SPECIFICATIONS MAY VARY, NO SINGLE LITE OF GLASS SHALL DEFLECT MORE THAN 3/4" (19.1mm)
 ALONG SUPPORTED EDGE.

ALLOWABLE WIND LOAD STRESS
 YKK AP tested standard. Contact YKK AP for more information.

These charts include unbraced length analysis and are based off at least one horizontal being placed at the midpoint of the span. For other applications, please contact YKK AP engineers at 1-866-955-2732.

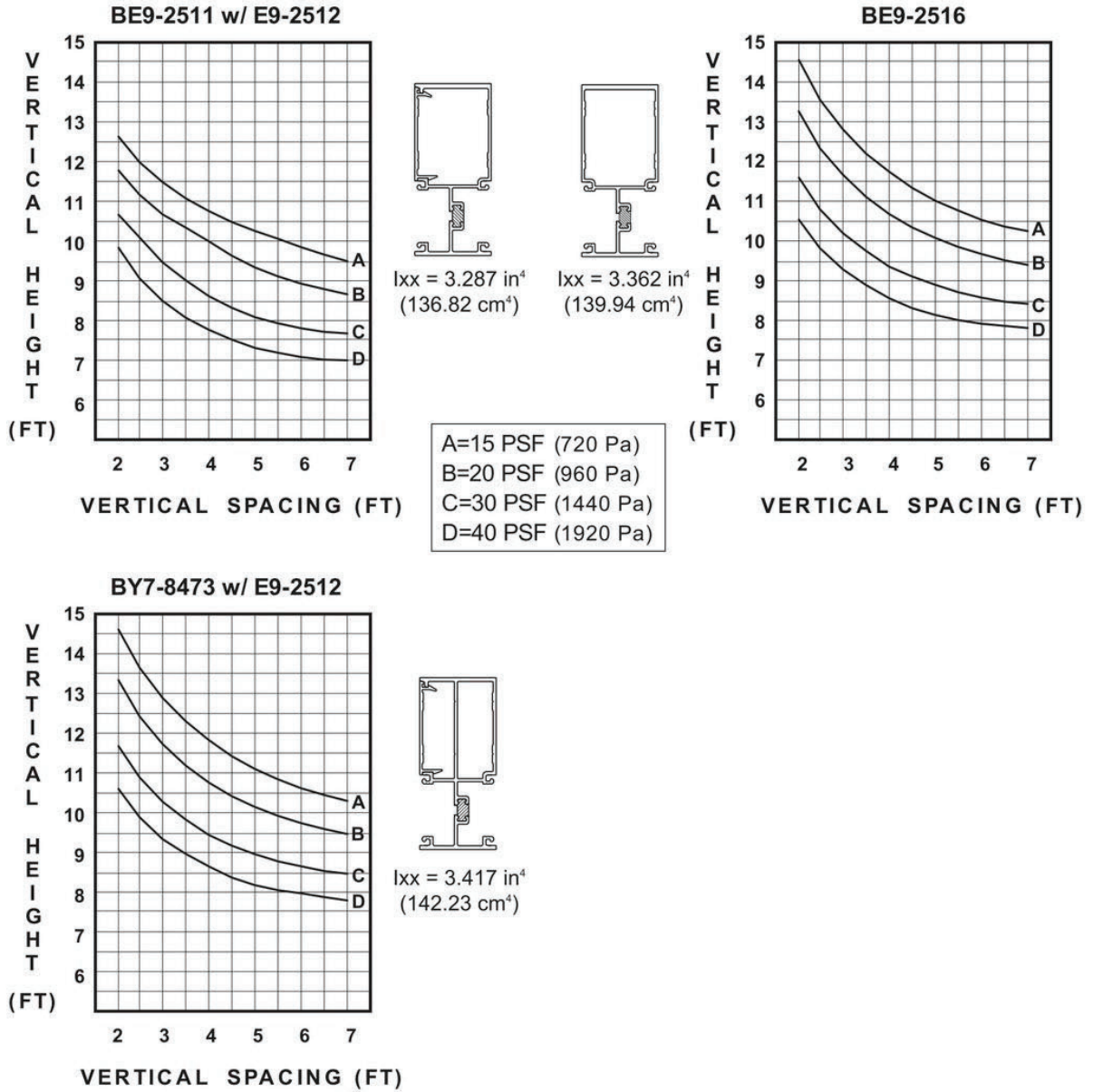

YES 45 TU FRONT SET DEAD LOAD CHARTS

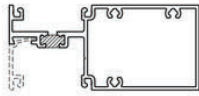

BE9-2515

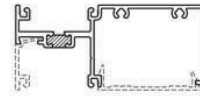
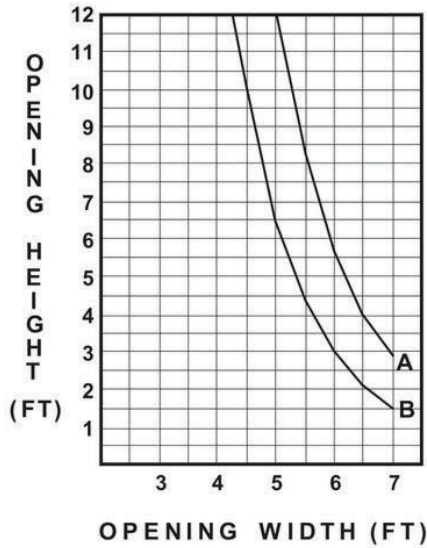

BE9-2517

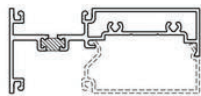
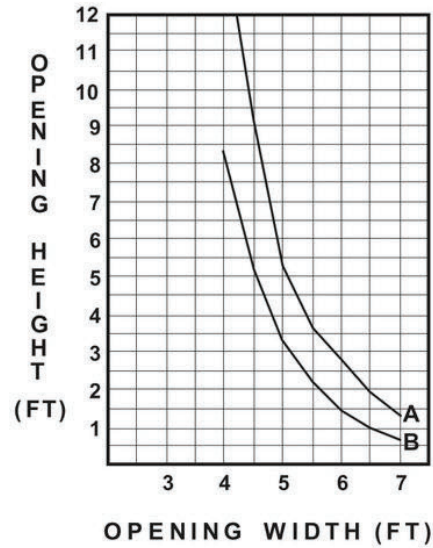

BE9-2522

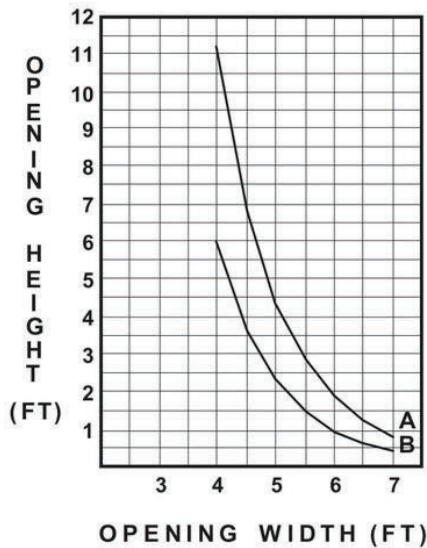

A = Setting Blocks at 1/8 Point Locations
 B = Setting Blocks at 1/4 Point Locations

Note: Dead load requirements are based upon a maximum deflection of 1/8" (3.2mm) at the center of the horizontal.

YES 45 TU FRONT SET SSG WIND LOAD CHARTS

