

Huerfano County
 Land Use Department
 401 Main Street, Suite 304
 Walsenburg, CO 81089
 719-738-1220 x506

**HUERFANO COUNTY
 ROADWAY DESIGN AND
 CONSTRUCTION
 STANDARDS
 SECTION 19.00
 TABLE OF CONTENTS**



<u>Section</u>	<u>Title</u>	<u>Page</u>
19.01.	GENERAL PROVISIONS	4
19.01.01.	Title	4
19.01.02.	Purpose	4
19.01.03.	Applicability	4
19.01.04.	Authority	4
19.01.05.	Amendments and Revisions	4
19.02.	ADMINISTRATION	5
19.02.01.	The County Road System	5
19.02.02.	Traffic Control Devices	5
19.02.03.	Road System Additions	5
19.03.	CONSTRUCTION DRAWING REQUIREMENTS.....	8
19.03.01.	General Requirements	8
19.03.02.	Cover Sheet	8
19.03.03.	Plan and Profile Sheets	8
19.03.04.	Cross sections	11
19.03.05.	Striping and Signing Plan	11
19.03.06.	Details	11
19.03.07.	Standard Notes	11
19.03.08.	Record Set Drawings	12
19.04.	FUNCTIONAL CLASSIFICATION.....	13
19.04.01.	General	13
19.04.02.	Huerfano County Roadway Classification Study	13
19.04.03.	Functional Classifications	13
19.04.04.	Urban and Rural Designations	13
19.05.	DESIGN STANDARDS	15
19.05.01.	General	15
19.05.02.	Design Period	15
19.05.03.	Policy on Use of Standards	15
19.05.04.	Road Right-of-Way	16
19.05.05.	Exception to Right-of-Way Standards	16
19.05.06.	Curb and Gutter	16
19.05.07.	Horizontal Curves	17
19.05.08.	Minimum Radii Based on Design Speed	18
19.05.09.	Vertical Alignment	21
19.05.010.	Intersections	26
19.05.011.	Cul-de-Sac Road Lengths	28
19.05.012.	Dead End Roads	28
19.05.013.	Pavement Cross Section Slopes	28
19.05.014.	Cross Section in Road Dip Sections	28
19.05.015.	Medians	29
19.05.016.	Design Speed	29
19.05.017.	Superelevation in Curves	30
19.05.018.	Bridges	30
19.05.019.	Guardrail	31
19.05.020.	Private Roads within Previously Dedicated Public Right-of-Way	32

**HUERFANO COUNTY
 ROADWAY DESIGN AND
 CONSTRUCTION
 STANDARDS
 SECTION 19.00
 TABLE OF CONTENTS**



<u>Section</u>	<u>Title</u>	<u>Page</u>
19.05.021.	Mailboxes	32
19.06.	PAVEMENT STRUCTURE DESIGN.....	33
19.06.01.	General Policy	33
19.06.02.	Pavement Structure Design Report	33
19.06.03.	Design Considerations	34
19.06.04.	Full Depth Asphalt	36
19.06.05.	Layered Design Analysis	36
19.06.06.	Gravel Road Design	36
19.07.	ROADWAY ACCESS.....	38
19.07.01.	Authority	38
19.07.02.	Purpose	38
19.07.03.	Implementation	38
19.07.04.	Application for a Permit and Issuance of Permits	39
19.07.05.	Access Control Standards	39
19.07.06.	Construction of Access	41
19.07.07.	Use of Access	42
19.07.08.	Illegal Accesses	42
19.07.08.01.	Policy for Correcting Illegal Accesses	43
19.07.09.	Drainage	43
19.07.010.	Driveways	43
19.07.011.	Driveway Location Limitations	45
19.07.012.	Speed Change Lanes	45
19.07.013.	Application Fees	50
19.07.014.	Damage to County Roadway and Improvements	50
19.08.	CONSTRUCTION SPECIFICATIONS.....	52
19.08.01.	General Policies	52
19.08.02.	Control of Work	52
19.08.03.	Authority of the Inspector	53
19.08.04.	The Project Engineer	53
19.08.05.	Inspection and Testing	53
19.08.06.	Removal of Unacceptable or Unauthorized Work	54
19.08.07.	Use of Approved Plans and Specifications	54
19.08.08.	Final Acceptance	55
19.08.09.	Modifications to CDOT Specifications	55
19.09.	CATTLE GUARDS ON PUBLIC ROADWAYS.....	57
19.09.01.	Definition.	57
19.09.02.	Request for installation.	57
19.09.03.	Maintenance and removal.	57
19.09.04.	Cattle Guard construction--County specifications to be met.	58
19.09.05.	County responsible after approval.	58
19.09.06.	Replacement, abandonment or discontinuance by County.	58
19.010.	EXCAVATIONS & R.O.W. OPENINGS FOR SUBSURFACE UTILITIES.....	61
19.010.01.	Applicability.	61
19.010.02.	Plans to be submitted before work begins.	61
19.010.03.	Hold harmless agreement.	61

Huerfano County
 Land Use Department
 401 Main Street, Suite 304
 Walsenburg, CO 81089
 719-738-1220 x506

**HUERFANO COUNTY
 ROADWAY DESIGN AND
 CONSTRUCTION
 STANDARDS
 SECTION 19.00
 TABLE OF CONTENTS**



<u>Section</u>	<u>Title</u>	<u>Page</u>
19.010.04.	Bonding, insurance and warranty requirements.	61
19.010.05.	Permits.	62
19.010.06.	Public Convenience and Safety.	64
19.010.07.	Right-of-way openings.	64
19.010.08.	Backfill.	65
19.010.09.	Compaction.	66
19.010.010.	Compaction tests.	66
19.010.011.	Resurfacing.	67
19.010.012.	Inspections.	69
19.010.013.	Emergency work.	70
19.010.014.	Notice to excavators.	70
19.010.015.	Permit fee schedule.	71
19.011.	DEFINITIONS.....	73
	APPENDIX 1	75
	APPENDIX 2	105
	APPENDIX 3	107

Huerfano County
Land Use Department
401 Main Street, Suite 304
Walsenburg, CO 81089
719-738-1220 x506

**HUERFANO COUNTY
ROADWAY DESIGN AND
CONSTRUCTION
STANDARDS
SECTION 19.00**



19.01. GENERAL PROVISIONS

19.01.01. TITLE

These regulations together with all future amendments shall be known as the "Huerfano County Roadway Design and Construction Standards" (hereafter called STANDARDS).

19.01.02. PURPOSE

The purpose of these STANDARDS is to provide a uniform set of minimum standards for the design and construction of roadways and related improvements within Huerfano County. The intent of these STANDARDS is to provide for a minimum standard level of service. If it can be shown that an alternate design, material or procedure will provide a level of service equal to or better than the required design, material, or procedure, said alternate may be approved by the Board of County Commissioners.

19.01.03. APPLICABILITY

These STANDARDS apply to all new roadway facilities to be constructed within Huerfano County except where other jurisdictions have direct authority (e.g., Colorado Department of Transportation, County of Huerfano, etc.). It is recognized that improvements to existing roadway facilities and construction of new roadway facilities within old town sites or subdivisions may not be possible in complete conformance with these STANDARDS because of existing alignment or grades, poorly laid out lots, right-of-way restrictions or other conditions. In such conditions the Board of County Commissioners may approve variations from these STANDARDS where safety is not compromised, and where no increase in expected maintenance cost to the County would result.

19.01.04. AUTHORITY

These STANDARDS have been adopted pursuant to the authority conferred within: Article 28 of Title 30; Article 2 of Title 43 and other applicable sections of the Colorado Revised Statutes of 1973, as amended.

19.01.05. AMENDMENTS AND REVISIONS

These STANDARDS may, when deemed necessary, be altered, amended, or revised upon recommendation of the Huerfano County Administrator and upon resolution of the Huerfano County Board of County Commissioners after the appropriate public review.

**HUERFANO COUNTY
ROADWAY DESIGN AND
CONSTRUCTION
STANDARDS
SECTION 19.00**



19.02. ADMINISTRATION

19.02.01. THE COUNTY ROAD SYSTEM

The Board of County Commissioners has adopted a Huerfano County Road Map showing all roads that have been officially made a part of the County Road System. This map is updated annually to reflect all additions, deletions and alterations to the County Road System. All open, used and maintained public roadways in the un-incorporated area of the County are shown.

19.02.02. TRAFFIC CONTROL DEVICES

All traffic control devices installed on County roads shall conform to the most recent edition of the Manual on Uniform Traffic Control Devices and any manual or supplement thereto approved and distributed by the Colorado State Highway Commission. The County shall be responsible for conducting any accident studies, traffic analysis, traffic control studies or other engineering studies required by state law or by the Manual on Uniform Traffic Control Devices which are prerequisite for the installation of traffic control devices on County roads, except as otherwise provided in a condition of a land use approval.

19.02.03. ROAD SYSTEM ADDITIONS

The Board of County Commissioners is authorized by Section 43-2-112, C.R.S. 1973, to layout, widen, alter or change any County road and to acquire lands of private persons for County roads. The County has staff responsibility for the planning, design, right-of-way acquisition, construction and inspection of all improvements to the existing County Road System. Roads constructed by others will ordinarily pass through eight (8) steps: planning, design, right-of-way acquisition/dedication, construction, and inspection recommendation for acceptance. Maintenance responsibilities and acceptance of maintenance responsibilities will generally remain with the Developer or Home Owners Association.

19.02.03.01. Planning

The planning or layout of a new road shall be in accordance with the Huerfano Comprehensive Development Plan. If a road is created through the subdivision process, all provisions of the Huerfano County Subdivision Regulations must be met.

19.02.03.02. Design

The design of any new road shall be in accordance with Section 19.05 of these STANDARDS. Road plans and specifications shall be prepared by a professional engineer licensed to practice in the State of Colorado. Plans and specifications are subject to the approval of

**HUERFANO COUNTY
ROADWAY DESIGN AND
CONSTRUCTION
STANDARDS
SECTION 19.00**



the Board of County Commissioners. Plan approval shall be good for one year, after which the Director of Planning may require that revised plans be submitted to reflect any changes in these STANDARDS or referenced specifications.

19.02.03.03. Right-of-Way Dedication/ Acceptance

A road created through the subdivision process shall have a specified right-of-way width shown on the plat along with a dedication statement. Acceptance of the plat by Huerfano County constitutes acceptance of the right-of-way, but does not constitute acceptance of the road for maintenance. The road does not become accepted for maintenance and part of the County Road System until it is constructed according to these STANDARDS and specifically accepted for maintenance by resolution of the Board of County Commissioners.

In certain circumstances a public road right-of-way may also be deeded to the County outside of the subdivision process. Any right-of-way conveyed by deed shall meet the same standards relative to width, alignment, etc. as roads created through the subdivision process. Prior to recommending acceptance of any deed for right-of-way, the County may require the submittal of a survey plat, prepared by a professional land surveyor licensed to practice in the State of Colorado. Acceptance of the deed by Huerfano County constitutes acceptance of the right-of-way, but does not constitute acceptance of the road for maintenance. The road does not become accepted for maintenance and part of the County Road System until it is constructed according to these STANDARDS and specifically accepted for maintenance by resolution of the Board of County Commissioners.

19.02.03.04. Construction

Construction of new County roads shall comply with the provisions of Section 19.08.

19.02.03.05. Inspection

Adequate inspections by the county ensure compliance with these STANDARDS and are the basis for the recommendation of the County Administrator for acceptance of the roads for maintenance and release of performance guarantees required by the Huerfano County Subdivision Regulations. Requirements for inspections are contained in Section 19.08.

19.02.03.06. Acceptance of Public Roads for Maintenance

Roads within the jurisdiction of Huerfano County may be accepted for maintenance by the Board of County Commissioners by resolution only after the following requirements are met:

- a. The county has inspected the road in accordance with Section 19.08, and the County Administrator has recommended acceptance for maintenance.

**HUERFANO COUNTY
ROADWAY DESIGN AND
CONSTRUCTION
STANDARDS
SECTION 19.00**



- b. The road connects to another maintained County road, state highway or city road.
- c. If within a subdivision, the road terminates at an intersection or is constructed with an approved cul-de-sac.
- d. All required road signs and traffic control devices have been installed in accordance with these standards.
- e. A performance bond for 15% of the total cost of construction of the road has been submitted to the County to warrant the road construction for one year after the date of acceptance, OR at the developer's option:

The final 15% of the collateral securing a subdivision improvements agreement covering construction of the road in question will not be released until the one-year warranty period is over; OR

The road will not be accepted for maintenance for a one period after the time of completion of all improvements. At the conclusion of the one-year period the Road and Bridge Department will inspect the improvements and notify the developer in writing of any necessary repairs.

All such repairs shall be completed by the developer prior to acceptance of the road for maintenance by Huerfano County.

- f. All required subsurface utilities, including service stubs, under or within three feet (measured horizontally) of the physical road (including shoulder and curb and gutter) have been installed prior to finishing sub-grade. Utility installations that will be located within the right-of-way but which involve no roadway cuts may be installed later, subject to the approval of the Board of County Commissioners.
- g. As-built plans signed by a licensed professional engineer have been submitted to the Planning Department, which depict all approved design modifications or significant departures from the original approved plans and specifications.

19.02.03.07. Traffic Estimates for Design

All traffic estimates for design required within these STANDARDS shall be based upon estimates provided in Trip Generation, latest edition, by the Institute of Traffic Engineers. Traffic estimates for uses or facilities not covered within that publication will be as approved by or supplied by the County Administrator.

**HUERFANO COUNTY
ROADWAY DESIGN AND
CONSTRUCTION
STANDARDS
SECTION 19.00**



19.03. CONSTRUCTION DRAWING REQUIREMENTS

19.03.01. GENERAL REQUIREMENTS

The construction drawing submittal shall be a complete package which includes all details and documentation necessary for the construction of the proposed improvements. All plans shall be prepared by or under the direction of a professional engineer licensed to practice in the State of Colorado.

19.03.02. COVER SHEET

A cover sheet shall be provided with each submittal involving multiple roads or sheets. Cover sheets shall contain:

- a. A vicinity map at a minimum scale of 1" = 2000' which shows the location and name of all arterial or collector roads within one mile of the development and all roads within the proposed development.
- b. Legend.
- c. Name or company name, address and phone number of the engineer preparing the plans.
- d. General notes.
- e. Description and location of permanent vertical bench mark based on U.S.G.S. datum. Where it is not practical due to lack of available existing benchmarks in the area of the development, the plans may reflect an assumed bench elevation upon approval of the Director of Planning. In the case of an assumed bench elevation a minimum of two benchmarks will be established and identified on the plan. All such bench marks shall be located within the proposed development or within public right-of-way adjoining the development.
- f. Name and phone number of all utility companies with mains, lines, or facilities potentially impacted by the construction.

19.03.03. PLAN AND PROFILE SHEETS

Plan and profile sheets shall be submitted for all proposed roadway construction. Plan view shall include, but not be limited to, the following:

- a. The scale shall be a minimum of 1" = 50'.

**HUERFANO COUNTY
ROADWAY DESIGN AND
CONSTRUCTION
STANDARDS
SECTION 19.00**



- b. Locations and dimensions of existing and proposed property lines, easements, and rights-of-way.
- c. Lot numbers and lot lines and dimensions if the road is within a platted subdivision.
- d. Road names.
- e. Survey and project centerline stationing.
- f. Centerline stations for all intersecting roads, public and private, and for commercial or industrial driveways.
- g. Existing improvements shall be depicted by dashed lines and proposed improvements by solid lines. Existing and proposed road improvements include curb and gutter, sidewalk, pavement, culverts, guardrail, etc., and includes all structures and appurtenances whether public or private within the right-of-way.
- h. Curve information including radius, interior angle, curve length, and tangent.
- i. Elevation and stationing for all curb returns, points of curvature, points of tangency, angle points and high or low point of vertical curves.
- j. Rate of superelevation if applicable.
- k. . Match lines and adjoining sheet numbers.
- l. Existing and proposed utilities, both overhead and underground, including but not limited to water, sewer, electric, gas, telephone, storm sewer and cable television.
- m. Stations and critical elevations of all utility and drainage appurtenances, existing and proposed.
- n. Traffic control signing and striping.
- o. Erosion control measures.
- p. Landscaping.

Profile view shall include, but not be limited to:

- a. Vertical scale of a minimum of 1" = 5'.
- b. Existing grades shall be depicted with dashed lines, proposed grades shall be

Huerfano County
Land Use Department
401 Main Street, Suite 304
Walsenburg, CO 81089
719-738-1220 x506

**HUERFANO COUNTY
ROADWAY DESIGN AND
CONSTRUCTION
STANDARDS
SECTION 19.00**



depicted with solid lines.

c. Continuous stationing for the entire portion of the roadway shown in the plan view, with the centerline stationing of all intersecting roadways, public and private, and commercial and industrial driveways clearly labeled.

d. All design elevations shall represent roadway centerline finish elevation. Additional profile views of curb and gutter, etc. shall be included as needed for clarity.

e. Vertical curve data including length of curve and stationing and elevation of p.v.t., p.v.i., p.v.c., high/low point.

**HUERFANO COUNTY
ROADWAY DESIGN AND
CONSTRUCTION
STANDARDS
SECTION 19.00**



19.03.04. CROSS SECTIONS

Cross sections will not normally be required. The Director of Planning may require cross sections when needed to clearly show the proposed method of widening or matching into existing improvements or method of handling steep side slopes.

19.03.05. STRIPING AND SIGNING PLAN

The signing plan shall show at a minimum:

- a. Location of all existing and proposed signs, clearly indicating if existing signs are to remain.
- b. Legend with reference to standard MUTCD designations.
- c. Typical detail of installation dimensions.
- d. Blank gauge and material of signs.
- e. Note reflectorization provided.

The striping plan shall show at a minimum as applicable:

- a. Striping material (paint, thermoplastic, etc.).
- b. Color designation and line width.
- c. Lane width.
- d. Line type (solid, skip, etc.).
- e. Typical details for any acceleration/deceleration lanes, turning lanes, cross walks, etc.

19.03.06. DETAILS

Huerfano County Standard Details or Colorado Department of Transportation Standard Details may be referenced without being reproduced on the plans where no modification to a standard is proposed or required. Any modifications to standards will require a specific detail to be included.

19.03.07. STANDARD NOTES

Huerfano County
Land Use Department
401 Main Street, Suite 304
Walsenburg, CO 81089
719-738-1220 x506

**HUERFANO COUNTY
ROADWAY DESIGN AND
CONSTRUCTION
STANDARDS
SECTION 19.00**



The following general notes shall appear on the cover sheet or first sheet of all construction plan sets:

- a. A traffic control plan must be submitted to the Huerfano County Road and Bridge Department prior to the issuance of an excavation permit. The traffic control plan must comply with the standards set forth in the Manual of Uniform Traffic Control Devices (MUTCD). The traffic control plan must be signed by an individual certified by the Colorado Department of Highways (CDOH) or the American Traffic Safety Services Association (ATSSA), as a Worksite Traffic Control Supervisor, whose signature shall constitute certification that the plan meets or exceeds MUTCD standards. Included with this plan shall be a detailed drawing of the project location showing all phases of the project, a list of the posted speed limits throughout the project, and a detailed drawing of the traffic control measures to be employed on the project site.
- b. The contractor shall notify the Huerfano County Planning Department at least seven days before starting construction of any public improvements or any construction within the County right-of-way.

19.03.08. RECORD SET DRAWINGS

No set of construction plans will be considered to have final approval, nor will construction be allowed to begin until two complete record set copies of the plans have been submitted to the Planning Department. The record set will be clearly marked "Record Set", and shall bear the signature and seal of the professional engineer responsible for their preparation on every sheet of the plans.

**HUERFANO COUNTY
ROADWAY DESIGN AND
CONSTRUCTION
STANDARDS
SECTION 19.00**



19.04. FUNCTIONAL CLASSIFICATION

19.04.01. GENERAL

The Colorado Department of Transportation (CDOT) has classified all roads within Huerfano County in conformance with Highway Functional Classification Concepts, Criteria and Procedure by the United States Department of Transportation, Federal Highway Administration. Huerfano County believes it to be in the best interest of the public at large for Huerfano County's functional classification system and classification of each road to be as consistent as possible with the CDOT classification system. To better define and establish certain design requirements (right-of-way width, roadway width, etc.) the local road system classification has been sub-classified as Local Access, Local Minor Residential, Local Industrial, and Local Commercial.

19.04.02. HUERFANO COUNTY ROADWAY CLASSIFICATION STUDY

Huerfano County has adopted the Huerfano County Roadway Functional Classification Study and Huerfano County Roadway Functional Classification Map. The Study and Map are periodically revised and updated.

19.04.03. FUNCTIONAL CLASSIFICATIONS

There are nine road classifications based upon the type and level of service for which the roads are intended. Table 1 in Appendix 2 lists the key design requirements for each of the classifications, and typical cross sections are found in Figures 1 through 9 in Appendix 1.

19.04.04. URBAN AND RURAL DESIGNATIONS

For the purposes of these standards and specifically for determining the appropriate cross-section to be used for a specific road the term urban--and therefore the urban cross-section--shall apply for any road or subdivision where one or more of the following is true:

1. The site lies within an area covered by an approved master drainage plan adopted into the Huerfano Comprehensive Development Plan, and said master drainage plan recommends curb and gutter and/or storm sewer for the road or site in question.
2. The site or road in question carries any of the following zone designations per the Huerfano County Zoning Resolution: Agricultural (A), Rural Residential (RR), Urbanizing Residential (UR), Commercial-Service (C) and Industrial (I).
3. Predominate design grades for the road or roads in question are 1 percent or less.

**Huerfano County
Land Use Department
401 Main Street, Suite 304
Walsenburg, CO 81089
719-738-1220 x506**

**HUERFANO COUNTY
ROADWAY DESIGN AND
CONSTRUCTION
STANDARDS
SECTION 19.00**



4. A roadside drainage ditch adequate to accommodate the 25-year storm event (with maximum 3:1 side slopes and conforming to all other applicable County standards) would be too large to fit within the available road right-of-way without decreasing the width of the roadway itself from the minimum standard.
5. Prevailing character of the surrounding area is consistent with an urban setting-- roads are constructed in general conformance with the urban cross-section.
6. The combination of drainage control, access control, pedestrian protection and other factors specific to the site are such that the Board of County Commissioners deems curb and gutter and sidewalk to be in the best interest of the public health, safety, and welfare.

Huerfano County
Land Use Department
401 Main Street, Suite 304
Walsenburg, CO 81089
719-738-1220 x506

**HUERFANO COUNTY
ROADWAY DESIGN AND
CONSTRUCTION
STANDARDS
SECTION 19.00**



19.05. DESIGN STANDARDS

19.05.01. GENERAL

This section describes the geometric requirements for each road classification and the maximum and minimum standards applicable to the horizontal and vertical layout of the roads. The Section also covers subjects such as driveway entrances, pavement transitions and design, roadway structures, construction, etc. Almost all requirements are based on safety considerations; therefore, standards which provide a greater degree of safety may be used within reasonable economic limits, but standards which could provide conditions less safe than those described in this Section shall not be used.

19.05.02. DESIGN PERIOD

Geometric designs shall be based on estimated traffic volumes projected 20 years into the future. Variations in this design period may only be authorized by the Board of County Commissioners.

19.05.02.01. Level of Service

All collector and arterial roads shall be designed to provide a level of service C or higher at the 20-year design point. Local roads may be designed to a level of service D.

19.05.03. POLICY ON USE OF STANDARDS

AASHTO Standards

The American Association of State Highway and Transportation Officials (AASHTO) has published policies on highway practice. These are approved references to be used in conjunction with this Section. AASHTO policies represent nationwide standards which do not always satisfy local conditions. When standards differ, the instruction in this Section shall govern.

MUTCD Standards

All traffic control devices and road striping must be in accordance with the Manual on Uniform Traffic Control Devices (MUTCD) prepared by the U.S. Department of Transportation.

ITE Standards

Unless otherwise approved by the Board of County Commissioners, all traffic generation estimates shall be in accordance with the publication Trip Generation by the Institute of Transportation Engineers.

**HUERFANO COUNTY
ROADWAY DESIGN AND
CONSTRUCTION
STANDARDS
SECTION 19.00**



CDOT Standards

Unless otherwise specified herein or specifically modified herein, the Colorado Department of Transportation's M & S Standards and Standard Specifications for Road and Bridge Construction shall control the design and construction of roadway improvements or details not specifically covered by these Standards.

19.05.04. ROAD RIGHT-OF-WAY

The right-of-way requirements shown in Figures 1 through 9 of Appendix 1 and Table 1 of Appendix 2 are based on the minimum space needed for each classification of road when it is constructed to meet ultimate development requirements. The right-of-way must also be adequate to accommodate those utility lines which should be laid outside the road pavement areas.

Adequate right-of-way must be provided for cut or fill slopes, bike paths, sidewalks, traffic control, drainage structures, fire hydrants and other public facilities when required.

19.05.05. EXCEPTION TO RIGHT-OF-WAY STANDARDS

Reduced road right-of-way widths may be approved by the Board of County Commissioners when it can be demonstrated that for a specific location the standard width would be in excess of all known road improvement requirements or when existing or proposed development in the immediate area would make the standard width inappropriate. Normally, when reduced right-of-way widths are allowed a public utility and drainage easement is required between the reduced width and the standard width.

Right-of-way widths in excess of the standard width may be required in special circumstances such as when:

- Cut or fill slopes cannot be confined within the standard width;
- Minimum sight distance lines on horizontal curves are not within the standards;
- Minimum sight distances at intersections are not within the standards;
- Auxiliary lanes are to be provided;
- Additional right-of-way is required to accommodate storm water drainage facilities.

19.05.06. CURB AND GUTTER

**HUERFANO COUNTY
ROADWAY DESIGN AND
CONSTRUCTION
STANDARDS
SECTION 19.00**



19.05.06.01. Type of Curb and Gutter

Vertical curbs are also called "barrier curbs". They deter vehicle operators from driving onto areas not intended for vehicular use, control parking and provide a channel for longitudinal road drainage. Vertical curbs are required on urban roads. Vertical curbs with gutters are to be constructed in accordance with CDOT Standard M-609-1, Type 2, Section IIB.

The "alternate ramp curb and gutter" depicted in Figure 27 of Appendix 1 may be approved by the Planning Department for certain urban roads subject to the following conditions:

- The road on which the curb is proposed is a low volume, low speed road classified as Local Access or Local Minor Residential.
- The proposed road improvements are fronting a predominately undeveloped area or new subdivision, making it difficult or impossible to ascertain eventual driveway locations.
- It can be demonstrated that all storm drainage entering onto the road will be handled in accordance with County standard criteria.

19.05.06.02. Curb Returns at Road Intersections

The minimum radii for curb returns measured to the back of the curbs shall be in accordance with the following:

Minimum 15 feet when both roads are classified local access.

Minimum 25 feet when one of the roads is classified minor collector or higher. Minimum

25 feet when one or both are classified local commercial.

Minimum 30 feet when one or both are classified local industrial.

Minimum 30 feet when both are classified minor collector or above.

All curb returns shall be provided with sidewalk from PC to PT of the same width as that provided for the sidewalk behind the tangent curb section.

19.05.07. HORIZONTAL CURVES

Horizontal alignment should provide for safe and continuous operation of motor vehicles at uniform design speed for substantial lengths of road. A horizontal curve is required when the angle of change in horizontal alignment is equal to or greater than one degree. The minimum radius of curvature will be determined by the design speed or by the stopping sight distance.

Huerfano County
Land Use Department
401 Main Street, Suite 304
Walsenburg, CO 81089
719-738-1220 x506

**HUERFANO COUNTY
ROADWAY DESIGN AND
CONSTRUCTION
STANDARDS
SECTION 19.00**



19.05.08. MINIMUM RADII BASED ON DESIGN SPEED

The table shown below provides a minimum radius of curvature for each of several selected design speeds with and without superelevation of 0.02 ft/ft. Wherever possible, the radii used in design should be larger. If stopping sight distance conditions require a larger radius than one shown in the following table, then the larger radius shall be used. All listed radii are to centerline.

**HUERFANO COUNTY
 ROADWAY DESIGN AND
 CONSTRUCTION
 STANDARDS
 SECTION 19.00**



19.05.08.01. Consideration of Stopping Sight Distance

When items such as walls, buildings, bridge piers, cut slopes, or vegetation growth are near the roadway on the inside of a curve, they can block a driver's view of the road ahead. If they are too close, the driver will not have sufficient distance along the curved roadway to stop when a hazardous condition comes into view. It is assumed that the driver's eye is 3.5 feet above the center of inside lane (the driving lane closest to the inside of curve) and that the hazardous condition is an object 0.5 feet high in the center of the inside lane. The line of sight is assumed to intercept the view obstruction at the mid-point of the line of sight 2.0 feet above the center of the inside lane. The clear distance, M, is measured from the center of the inside lane to the view obstruction. The following is a table of minimum stopping sight distances for various design speeds:

Design Speed (MPH)	Minimum SSD (FT)
20	125
25	155
30	200
35	245
40	300
45	370
50	450
55	545
60	645
65	750

The following equations are to be used when the length of the curve on the center of the inside lane must be equal to or greater than the stopping sight distance for the roadway:

- Assuming that the roadway geometry and design speed are fixed, the stopping sight distance, S, and the radius to the center of the inside lane, R, will be known. The distance, M, found by the following equation will be the closest that an obstruction can be placed to the center of the inside lane:

$$M = R[1 - \cos(28.65 S/R)]$$

- If the radius R (for example the minimum radius based on design speed) and the distance, M, are tentatively selected, then the length, L, of the arc in the middle of the inside lane may be found by the following equation:

$$L = (R/28.65)\cos^{-1}[(R-M)/R]$$

If the length, L, is less than the stopping sight distance for the desired design speed, either the radius, R, or the distance, M, must be increased.

**HUERFANO COUNTY
 ROADWAY DESIGN AND
 CONSTRUCTION
 STANDARDS
 SECTION 19.00**



19.05.08.02. Reduced Design Speed on Curves

The reduction of a road design speed on a curve should be avoided; however, where physical restrictions prohibit increasing the radius of the curve or the clear distance, M, the design speed for the curved section may be reduced with the approval of the Board of County Commissioners. In such circumstances, signing in accordance with the MUTCD is required. The difference between the design speed for the roadway approaching the curve and the design speed for the curve must not be greater than 10 MPH. The design speed for a curved roadway section must not be reduced if the reduction would occur at the end of a long tangent or at any location where high approach speeds may be expected.

19.05.08.03. Central Angles Not Requiring Curves

For central angles smaller than 1 degree no curve is required. In no event shall sight distance nor other safety considerations be sacrificed when a curve is not provided.

19.05.08.04. Compound Curves

A compound curve should be avoided; however, if site conditions make the use of a compound curve unavoidable, the shorter radius shall be at least 2/3 the longer radius when the shorter radius is 1,000 feet or less. Compound curves are not permitted when design speeds require the shorter radius to be greater than 1,000 feet.

19.05.08.05. Tangent Sections Between Curves in the Same Direction

On two-lane roads, tangent sections are needed between two curves in the same direction. If the pavement cross sections through the curves do not have superelevation, the minimum lengths for tangent sections are listed in the following table:

Design Speed (MPH)	Tangent Length (FT)
20	---
25	250
30	300
35	400
40	500
45	500
50	500
55	660
60	660
65	660

**HUERFANO COUNTY
 ROADWAY DESIGN AND
 CONSTRUCTION
 STANDARDS
 SECTION 19.00**



If superelevation is provided in the curved portions of the roadway, then the tangent lengths will be determined by the superelevation transition lengths, which shall be in accordance with the AASHTO publication, A Policy on Geometric Design of Highways and Roads.

19.05.08.06. Tangent Sections Between Reverse Curves & Approaching Intersections

A tangent section must be provided between two curves that curve in the opposite direction. A tangent section must also be provided between an intersection and a curve. If the pavement cross sections through the curves do not have superelevation, the minimum lengths for such tangent sections are listed in the following table:

Design Speed (MPH)	Tangent Length (FT)
20	---
25	100
30	150
35	200
40	250
45	250
50	300
55	300
60	400
65	500

If the curve radii are at least 50% greater than the radii required by the design speed, the tangent sections may not be required, depending on grades, topography and vegetation. If the curves are superelevated the superelevation transition lengths indicated in Table 1 will determine the minimum length of tangent sections between reverse curves.

19.05.08.07. Spiral Curves

Spiral curves are not permitted.

19.05.09. VERTICAL ALIGNMENT

The use of changes in the vertical alignment or grade of a road is necessary for many reasons including changes in topography, drainage requirements and aesthetic factors. A vertical curve is required when a grade change equal to or greater than 2.0% occurs. All sections of a road's vertical alignment must meet stopping and passing sight distance requirements for the design speed established for the road. When considering alternative grade profiles, economic and aesthetic comparisons should be made. For further details, see the AASHTO publication, A Policy on Geometric Design of Highways and Roads.

**HUERFANO COUNTY
ROADWAY DESIGN AND
CONSTRUCTION
STANDARDS
SECTION 19.00**



19.05.09.01. Longitudinal Road Grades

Maximum and minimum grades for each functional classification are listed in Table 1. Longitudinal road grades which do not comply with Table 1 must be approved by the Board of County Commissioners. Approval will not be granted if safety is compromised, or in the absence of compelling physical constraints.

19.05.09.02. Steep Grades in Mountainous Areas

In mountainous areas, often it is not physically or economically feasible to design a grade profile that will allow uniform operating speeds for all vehicles. Sometimes a long, sustained gradient is unavoidable. A grade profile with sections of maximum gradient, broken by lengths of flatter grade, is preferable to a long, sustained grade only slightly below the maximum allowable.

19.05.09.03. Vertical Curves

Properly designed vertical curves should provide adequate sight distance, safety, comfortable driving, good drainage, and pleasing appearance.

Flat vertical curves may develop poor drainage at the level section. This difficulty may be overcome by a slight adjustment in the grade of gutter or other roadside drainage facility or by shortening the vertical curve. On 2-lane roads where extremely long vertical curves are necessary (over 1,320 feet), it is sometimes more economical to use 4-lane construction than to obtain passing sight distance by the use of a long vertical curve. Broken-back vertical curves (two vertical curves in the same direction separated by a short grade tangent) should be avoided.

Curve Criteria

1. Type of Curve

A parabolic vertical curve is to be used. Figure 10 in Appendix 1 gives all the necessary mathematical relations for computing a vertical curve, either crest or sag.

2. Sight Distance Requirements

Sight distance is the continuous length of road ahead which is visible to the driver. In design, two sight distances are considered: passing sight distance and stopping sight distance. Stopping sight distance is the minimum sight distance to be provided at all points on multi-lane roads and on two-lane local roads where passing sight distance is not required. Stopping sight distance shall also be provided for all elements of intersections at grade, including private road connections.

**HUERFANO COUNTY
 ROADWAY DESIGN AND
 CONSTRUCTION
 STANDARDS
 SECTION 19.00**



a. Stopping Sight Distance

The minimum stopping sight distance is the distance required by the driver of a vehicle, traveling at a given speed, to bring the vehicle to a stop after an object on the road becomes visible.

Stopping sight distance is measured from the driver's eyes, which are assumed to be 3.5 feet above the road surface, to an object 0.5 feet high on the road.

b. Passing Sight Distance

Passing sight distance is the minimum sight distance that must be available to enable the driver of one vehicle to pass another vehicle safely and comfortably, without interfering with the speed of an oncoming vehicle traveling at the design speed should it come into view after the passing maneuver is started. The sight distance available for passing at any location is the longest distance at which a driver whose eyes are 3.5 feet above the road surface can see the top of an object 4.25 feet high on the road.

c. Sight Distance Standards

The following table shows the minimum sight distances to be used for specific design speeds:

Design Speed (MPH)	Minimum Sight Distance	
	Stopping (ft)	Passing (ft)
20	125	800
25	155	950
30	200	1100
35	245	1300
40	300	1500
45	370	1650
50	450	1800
55	545	1950
60	645	2100
65	750	2300

Basic considerations regarding these sight distances are covered in the AASHTO publication, [A Policy on Geometric Design of Highways and Roads](#).

3. Minimum Vertical Curve Length

Minimum vertical curve lengths are determined by sight distance requirements for a given design speed and the algebraic difference in grade for which the curve is being designed.

**HUERFANO COUNTY
ROADWAY DESIGN AND
CONSTRUCTION
STANDARDS
SECTION 19.00**



a. Crest Vertical Curve Lengths

Minimum crest vertical curve lengths are determined by either the stopping sight distances or the passing sight distances. A minimum curve length based upon passing sight distance for a given road design speed and algebraic grade difference will be several times greater than the curve length based upon stopping sight distance using the same parameters.

1. Roads with Four or More Traffic Lanes

Because these roads have traffic lanes in which vehicles may pass without meeting traffic moving in the opposite direction, the minimum crest vertical curve lengths must only meet stopping sight distance requirement; however, it is desirable that they also meet passing sight distance requirements.

2. Roads with Two Traffic Lanes

The minimum crest vertical curve lengths for two-lane roads shall meet passing sight distance requirements. When crest curve construction in accordance with passing sight distance requirements would result in the creation of drainage problems or excessive cuts or fills, the curve length may be reduced with the approval of the Board of County Commissioners and the installation of no-passing signs and pavement markings.

3. Minimum Curve Length Determined by Stopping Sight Distance

The following equations are to be used to determine the minimum crest vertical curve lengths based upon stopping sight distance requirements:

$$\text{When } S_s < L, L = S_s^2/1329$$

$$\text{When } S_s > L, L = 2S_s - 1329/A$$

Where:

S_s = Stopping sight distance in feet for a given design speed

L = Length of curve in feet

A = Algebraic grade difference in percent

4. Minimum Curve Length Determined by Passing Sight Distance

**HUERFANO COUNTY
ROADWAY DESIGN AND
CONSTRUCTION
STANDARDS
SECTION 19.00**



$$\text{When } S_p < L, L = AS_p^2/3093$$

$$\text{When } S_p > L, L = 2S_p - 3093/A$$

Where:

S_p = Passing sight distance in feet for a given design speed
 L = Length of curve in feet

A = Algebraic grade difference in percent

b. Sag Vertical Curve Lengths

Minimum sag vertical curve lengths are determined by either the stopping sight distance or by comfort factors. The longer of the two possible minimum curve lengths will be used.

1. Minimum Curve Length Determined by Stopping Sight Distance

The following equations are to be used to determine the minimum sag vertical curve lengths based upon stopping sight distance requirements:

$$\text{When } S_s < L, L = AS_s^2 / (400 + 3.5S_s)$$

$$\text{When } S_s > L, L = 2S_s - (400 + 3.5S_s)/A$$

Where:

S_s = Stopping sight distance in feet for a given design speed

L = Length of curve in feet

A = Algebraic grade difference in percent

2. Minimum Curve Length Determined by Comfort Factors

The following equation is to be used to determine the minimum sag vertical curve length based upon comfort factors:

$$L = AV^2/46.5$$

Where:

**HUERFANO COUNTY
ROADWAY DESIGN AND
CONSTRUCTION
STANDARDS
SECTION 19.00**



L = Curve length in feet

A = Algebraic grade difference in percent

V = Design speed in miles per
hour

19.05.010. INTERSECTIONS

19.05.010.01. Angle of Intersections

A right-angle intersection provides the shortest crossing distance for intersecting traffic streams. It also provides the most favorable condition for drivers to judge the relative position and speed of intersecting vehicles. Intersection angles which vary from a right-angle by more than 4 degrees are not permitted except on local roads where a divergence up to 15 degrees is permitted when approved by the Board of County Commissioners.

19.05.010.02. Alignment and Profile

Intersections occurring on horizontal or crest vertical curves are undesirable from the standpoint of operation and sight distance. When there is latitude in the selection of intersection locations, vertical or horizontal curvature should be avoided. A line or grade change is frequently warranted when major intersections are involved. If a curve is unavoidable, it should be as flat as site conditions permit. Where the grade of the through roadway is steep, flattening through the intersection area is desirable as a safety measure.

19.05.010.03. Intersection Sight Distance

In order to provide the opportunity for vehicles on a stop-controlled intersection leg to safely cross or make left or right turns onto a non-controlled intersection leg, adequate sight distance must be provided. Two sight distance triangles may be drawn to represent the areas which must be free of all objects, vegetation and topography in excess of two feet above the road surface below the driver's eye on the stop-controlled intersection leg. The AASHTO publication, A Policy on Geometric Design of Highways and Roads identifies the acceptable means for determining the size of the sight distance triangles based upon many variables, including speed, width of the non-controlled leg, etc. It is not practical to attempt to tabulate all possible combinations of the many variables. Each new road intersection or proposed modification of an existing road intersection shall be evaluated in accordance with the AASHTO procedure.

19.05.010.04. Median Openings at Road Intersections

**HUERFANO COUNTY
ROADWAY DESIGN AND
CONSTRUCTION
STANDARDS
SECTION 19.00**



1. Spacing and Location

If a road has a raised median, it may not be possible to have an opening in the median for every road intersection. Generally, median openings in arterial roads should be provided only for major cross roads. Median openings should be spaced at intervals no closer than 660 feet. If a median opening falls within 50 feet of an access driveway, it should be placed to include the access driveway.

2. Configuration of Openings

The configuration of median openings is to be determined by the AASHTO publication A Policy on Geometric Design of Highways and Roads.

3. Cross Slope

The cross-slope in the median opening shall be limited to a maximum of 0.02 foot per foot. Median openings on curves with superelevation rates exceeding 0.02 foot per foot will not be permitted.

19.05.010.05. Use of Cross Pans at Road Intersections

4. Locations Where Cross Pans Are Prohibited

Cross pans may not be used across roads in the following types of intersections:

- Arterial - Arterial
- Arterial - Collector
- Collector - Collector

Exceptions to this restriction may be approved by the Board of County Commissioners. The purpose of this restriction is to prevent the flow of nuisance water across arterial and collector roads on a frequent basis, and to maintain the traffic flow for which these classifications are required. The gutter profiles for arterial roads and collector roads should be designed with sag curves or sump conditions located as far away from the intersection as practical. This will allow the interception or removal of light storm water and nuisance water, with only the larger flows still reaching and passing through the intersection.

5. Cross Pan Widths

Where cross pans are normally allowed, they shall be designed and constructed in accordance with Colorado Department of Transportation M Standards. If the Board of County Commissioners approves the use of a cross pan across arterial or collector

**HUERFANO COUNTY
 ROADWAY DESIGN AND
 CONSTRUCTION
 STANDARDS
 SECTION 19.00**



roads the width must be designed to meet road design speed requirements. In no case will cross pans be less than 8 feet in width at road intersections on the stop controlled road, nor less than 12 feet in width for all other locations.

19.05.011. CUL-DE-SAC ROADLENGTHS

A cul-de-sac is a road that serves more than one property owner and has only one intersection with the public road system. The following requirements apply the creation by plat or deed of new cul-de-sac roads, both public and private. The length of a cul-de-sac is measured between the centerline of the intersecting road and the radius point of the cul-de-sac. The minimum length of a cul-de-sac road is two times the radius. A cul-de-sac road shall not be longer than 1320 feet and it shall not serve more than 20 single family dwelling units (and shall not serve uses projected to generate more than 200 vehicle trips per day in areas where the land use is other than single family residential).

19.05.012. DEAD END ROADS

Dead end roads will be allowed only where a future extension of the road would be necessary to serve adjacent properties when developed at a future date. When a dead end road is allowed, a temporary turn-around shall be provided. The maximum length of a dead end road shall be the same as the maximum length of a cul-de-sac road. Temporary tum-arounds shall match the physical requirements for cul-de-sac roads, and shall be provided with a temporary easement allowing for maintenance. Traffic control devices will be required that are designed to advise the motoring public of the existence of the dead end and to mark the end of the road.

19.05.013. PAVEMENT CROSS SECTION SLOPES

The typical road cross sections are found between road intersections where there are no dip sections for drainage flow across the road. Undivided roads should have a normal crown which is a two-way cross slope with the cross section high point on the road centerline. Divided roads should have a cross slope on each pavement section with the high point of each section on the edge of the pavement nearest to the median. Unusual conditions may cause cross slope requirements to vary, but normally the cross slope should be in accordance with the following: Standards for Pavement Cross Slopes

Surface Type	Road Type	Slope(%)
Portland Cement Concrete	All	2.0
Bituminous Pavements	Mix All	2.0-2.5
Gravel	Local	2.0-3.0

19.05.014. CROSS SECTION IN ROAD DIP SECTIONS

**HUERFANO COUNTY
ROADWAY DESIGN AND
CONSTRUCTION
STANDARDS
SECTION 19.00**



Where storm drainage runoff flows must cross the road, dip sections are required. The pavement through the dip section to carry the flow shall have a one-way slope (no crown) and curbing and medians must not be raised. Transitions back to normal road cross slopes will be required at both ends of the dip section.

19.05.015. MEDIANS

19.05.015.01. 5.15.1 MEASURING MEDIAN WIDTHS

The width of a median is measured from back of median curb to back of median curb. If the median has no curb, the width is measured between the centers of the continuous, painted median stripes.

19.05.015.02. Median Widths

Median widths are shown in Figures 1 and 2 in Appendix 1 for principal arterials and minor arterials. The widths shown shall be considered the minimum allowable widths. In special circumstances, the Board of County Commissioners may approve widths other than those listed, but in no case shall a median be constructed with a width less than 5 feet. If a median is to be landscaped, it shall not be less than 8 feet wide.

19.05.015.03. Paved Medians

A median less than 8 feet wide shall be paved. The paved surface should be crowned and have the same cross slope as the road pavement.

19.05.015.04. Unpaved Medians

Medians that are 8 feet or more wide are normally not paved. The grading of the unpaved areas shall be subject to the approval of the Board of County Commissioners and shall assure positive drainage away from the traveled roadways via storm sewer, culverts or other means that do not result in runoff flowing on or across the roadway surface. Additionally, unpaved medians shall be vegetated pursuant to a vegetation plan approved by the Planning Department.

19.05.016. DESIGN SPEED

The design of geometric features such as horizontal and vertical curves will depend upon the design speed selected for the road. The choice of the design speed is primarily determined by the road classification. The design speed is the maximum speed for safe operation of a vehicle that can be maintained over a specific section of a road when conditions are so favorable that the design features of the road govern. Design speeds for the various classifications of roads

**HUERFANO COUNTY
ROADWAY DESIGN AND
CONSTRUCTION
STANDARDS
SECTION 19.00**



may be found in Table 1. The use of design speeds other than those shown in Table 1 in Appendix 2 may be approved by the Board of County Commissioners.

19.05.017. SUPERELEVATION IN CURVES

19.05.017.01. Superelevation Rates

Superelevation rates of 0.02 ft/ft may be used on all classes of roads. Superelevation rates greater than 0.02 ft/ft may not be used except when specifically approved by the Board of County Commissioners. In no case may it exceed 0.06 ft/ft.

19.05.017.02. Transition for Superelevation

The length of superelevation transition shall be based upon the superelevation rate and the width of rotation. The axis of rotation shall generally be about the pavement centerline. The transition lengths for a superelevation of 0.02 ft/ft are provided in Table 1 in Appendix 2.

With respect to the beginning or ending of a horizontal curve, one-third (1/3) of the transition will be on the curve and two-third (2/3) of the transition will be on the tangent section.

19.05.017.03. Drainage on Superelevated Curves

Whenever superelevation is allowed on a divided road, a storm drainage system to collect the runoff along the median curb shall be provided. In no case shall nuisance water from the higher traveled way be allowed to cross over the lower traveled way.

19.05.018. BRIDGES

For the purposes of this section the term bridge shall mean any structure for the purpose of allowing a public road or trail to cross over any stream, gulch, ditch, drainage way, etc. and

having a span of 4 or more feet. This shall include box culverts and pipe culverts 48 inches or larger in diameter.

All bridge structures to be constructed within the public right-of-way shall be designed by a professional engineer licensed in the State of Colorado and qualified to perform such work. All bridge designs will be in accordance with the Standard Specifications for Highway Bridges adopted by AASHTO, latest edition, and the Colorado Department of Transportation's design and detail memos. Design loading for all bridge structures within a public right-of-way shall be HS 20-44.

19.05.018.01. Bridge Hydraulic Capacity

**HUERFANO COUNTY
 ROADWAY DESIGN AND
 CONSTRUCTION
 STANDARDS
 SECTION 19.00**



The required minimum hydraulic capacity for bridges shall be determined using a design storm frequency based on the following criteria (Q_{50} = peak flow from a 50 year storm event):

Road type	Q_{50}	storm frequency (yr)
Expressway	---	100
Principal Arterial	---	100
Minor Arterial	---	100
Major Collector (urban)	---	100
Major Collector (rural)	> 4000 cfs	50
	< 4000 cfs	25
Minor Collector (urban)	---	100
Minor Collector (rural)	> 4000 cfs	50
	< 4000 cfs	25
Local	> 4000 cfs	50
	< 4000 cfs	25

19.05.018.02. Bridges Within FEMA Designated Flood Hazard Areas

For any structure to be located within a FEMA designated flood hazard area, documentation will be submitted by the design engineer demonstrating that no increase in the 100-year flood elevation will occur due to the structure. Documentation will include Hec 2 analysis and an approved flood hazard area development permit.

19.05.018.03. Acceptance for Maintenance

No bridge structure will be accepted for maintenance by Huerfano County until the Road and Bridge Administrator has been provided with inspection reports prepared by a state approved bridge inspector demonstrating a minimum sufficiency rating of 95 pursuant to the CDOT Structure Inventory Coding Guide and the structure is accepted by resolution of the Board of County Commissioners. At the discretion of the Board of County Commissioners the County may have the bridge inspected along with other County structures during a regular inspection year and bill the bridge owner for the cost of the inspection and resulting report.

19.05.019. GUARDRAIL

Installation of guardrail may be required by the Board of County Commissioners. The AASHTO publication Roadside Design Guide and CDOT M standards will be used as guidelines by the Board of County Commissioners in evaluating the need for guardrail. When required, the installation of guardrail shall comply with CDOT specifications and M standards.

Huerfano County
Land Use Department
401 Main Street, Suite 304
Walsenburg, CO 81089
719-738-1220 x506

**HUERFANO COUNTY
ROADWAY DESIGN AND
CONSTRUCTION
STANDARDS
SECTION 19.00**



**19.05.020. PRIVATE ROADS WITHIN PREVIOUSLY DEDICATED PUBLIC
RIGHT-OF-WAY**

There are numerous road rights-of-way within Huerfano County which were created and dedicated to the public by subdivision plats that pre-date the present regulations (i.e. prior to August 1972). In many instances the roads were never actually constructed or were constructed too poorly to be accepted by the County for maintenance. Instances arise where a private property owner has no legal access to his/her property except over and across a platted, deeded or dedicated right-of-way in which no road exists. Huerfano County will not issue building permits nor certificates of occupancy for any property whose sole access is a public right-of-way not maintained by Huerfano County unless the person or persons desiring to use the right-of-way do one of the following:

- A. Construct the road from its intersection with a maintained public road to a point along the frontage of the property to be accessed which would provide a road frontage equal to or greater than the minimum lot width required by the zone district the property is located in, or the entire frontage of the property, whichever is less. Construction shall be in compliance with all County standards applicable to the road's functional classification. Upon completion of the construction in accordance with all applicable sections of these STANDARDS, application may be made for a building permit.
- B. Apply to the Board of County Commissioners for a vacation of the public road right-of-way. Prior to issuance of the building permit, the person or persons wishing to use the resulting private road for the sole access to their property will be required to record at the Huerfano Clerk and Recorder's office a waiver of maintenance, acknowledging that Huerfano County does not and will not maintain the road.

19.05.021. MAILBOXES

Mailboxes may be located within the public road right-of-way provided they do not create a roadside hazard, do not obstruct vehicular or pedestrian traffic, and do not unreasonably interfere with road maintenance activities such as snow plowing and weed mowing. On roads with traffic volumes in excess of 2000 vehicle trips per day, mailboxes shall be located at least 8 feet away from the edge of the traveled way and shoulder areas shall be provided which are adequate to support all weather vehicular traffic without damage to the public roadway, shoulder, or edge of roadway. Any variance to this requirement will be at the sole discretion of the Board of County Commissioners, and will be due to physical restraints beyond the control of the mailbox owner. In high density areas group or clustered mailboxes may be required. Mailboxes and their supporting structures shall not be allowed within sidewalks. Installation of mailboxes shall comply with Figures 12 through 14 in Appendix 1.

**HUERFANO COUNTY
ROADWAY DESIGN AND
CONSTRUCTION
STANDARDS
SECTION 19.00**



19.06. PAVEMENT STRUCTURE DESIGN

19.06.01. GENERAL POLICY

The procedure for the design of pavement structure sections shall be based upon the most recent edition of the Colorado Department of Transportation's Roadway Design Manual and the AASHTO Guide for Design of Pavement Structures. Minor modifications to the CDOT manual procedure and specific minimum values of constants or factors are specified herein.

19.06.01.01. Road Surfaces

It is the policy of Huerfano County that the surface of all new roads constructed within a public right-of-way shall be hot bituminous pavement (asphalt) or Portland cement concrete pavement. The sole exception to this policy is any road, which may be constructed with a final gravel surface--subject to the approval of the Board of County Commissioners -- provided:

- a. The projected traffic volume 20 years in the future does not exceed 100 vehicles per day.
- b. The proposed road profile and other design details combined with the surrounding topography and other characteristics will not create the potential for erosion and loss of gravel due to storm run-off.
- c. No special maintenance problems or difficulties due to the gravel surface are anticipated by the Board of County Commissioners considering the location and proposed use of the road.

19.06.01.02. Pavement Thickness

The required thickness of pavement shall be based upon the provisions of this Section 19.06. In no case, however, shall the thickness of hot bituminous pavement for a road to be maintained by the County be less than three inches.

19.06.02. PAVEMENT STRUCTURE DESIGN REPORT

A pavement design report shall be submitted prior to the approval of any roadway construction plans involving new pavement, overlay of existing pavement or widening of existing pavement. The report shall be prepared by a professional engineer licensed to practice in the State of Colorado.

The pavement design report shall include the following minimum information:

**HUERFANO COUNTY
 ROADWAY DESIGN AND
 CONSTRUCTION
 STANDARDS
 SECTION 19.00**



- a. Soil logs along the proposed roadway alignment at a maximum of 500 foot intervals. Logs shall include a soil profile for a minimum depth of four feet below the proposed sub-grade elevation.
- b. Each representative sample shall be classified according to the AASHTO Unified Soil Classification Table, and shall have an Atterberg Limits Test and sieve analysis performed.
- c. The pavement design procedure is based upon the resilient modulus, M_R , of the sub-grade soils. The value of M_R may be obtained from a HVEEM Stabilometer test "R" value by the following formulae:

to convert HVEEM "R" to soil support, S_1

$$S_1 = [("R" - 5)/11.29] + 3$$

to convert S_1 to M_R

$$M_R = 10^{(S_1 + 8.72)/6.24}$$

- d. Proposed average daily traffic volumes (ADT) for each road based on 100% of full development plus a 10% adjustment for construction traffic. Traffic analysis for the purpose of pavement design shall be as specified in Section 19.02.
- e. Recommended structural sections, based on the design considerations, proposed typical sections, and sections of roadway which may require additional stabilization or treatment.

19.06.03. DESIGN CONSIDERATIONS

The following elements are to be used in the design procedure:

- a. The design procedure is based on the number of 18,000-pound single axle Equivalent Design Load Applications (18K EDLA) per traveled lane. In no case shall the design 18K EDLA be less than the following values:

Local Minor Residential	5
Local Access	10
Local Commercial	30

**HUERFANO COUNTY
 ROADWAY DESIGN AND
 CONSTRUCTION
 STANDARDS
 SECTION 19.00**



Local Industrial	60
Minor Collector	50
Major Collector	100
Minor Arterial	200
Principal Arterial/expressway	300

- b. The serviceability loss, Δ PSI, for local roads and minor collectors shall be 2.5; for major collectors and arterials it shall be 2.0.
- c. The reliability factors used shall be the following:

Local Minor Residential	75
Local Access	75
Local Commercial	75
Local Industrial	75

Minor Collector	80
Major Collector	85
Minor Arterial	90
Principal Arterial/expressway	95

- d. Overall standard deviation, S_0 , shall be 0.44 for all designs.
- e. An adjustment to the structural layer coefficients for drainage conditions will not normally be needed for new construction. (Less than the fair drainage assumed under the CDOT method would not be allowed under new construction). In no case will structural layer coefficients be modified by a factor greater than 1.0. In those instances where, due to existing constraints or physical conditions, occasional moisture levels within the base or sub-base may approach saturation, the following factors will apply:

quality of drainage	percent of time pavement is exposed to moisture levels approaching saturation		
	< 1%	1 - 5%	5 -25%
fair	1.0	1.0	0.80
poor	1.0	0.80	0.60
very poor	0.95	0.75	0.40

- f. Strength coefficients per one-inch layer of a given material for layered pavement design purposes shall be as follows:

Huerfano County
 Land Use Department
 401 Main Street, Suite 304
 Walsenburg, CO 81089
 719-738-1220 x506

**HUERFANO COUNTY
 ROADWAY DESIGN AND
 CONSTRUCTION
 STANDARDS
 SECTION 19.00**



hot bituminous pavement	0.44
class 6 base course	0.12
class 2 sub-base course	0.10

Strength coefficients for specially treated base materials for design purposes must be approved by the Board of County Commissioners.

19.06.04. FULL DEPTH ASPHALT

Full depth asphalt designs will only be allowed with the approval of the Board of County Commissioners, and will not be allowed on clay sub-grade soils.

19.06.05. LAYERED DESIGN ANALYSIS

Layered structures (asphalt on aggregate base course) shall be designed in accordance with the principles shown in Figure 16 in Appendix 1. First, the structural number required over the sub-grade soil is computed. In the same way, the structural number required over the sub-base layer should also be computed, using the applicable strength values for each. By working with differences between the computed structural numbers required over each layer, the maximum allowable thickness of any layer can be computed. For example, the maximum allowable structural number for the sub-base material would be equal to the structural number required over the sub-base subtracted from the structural number required over the sub-grade soil. In a like manner, the structural numbers of the other layers may be computed. The thickness for the respective layers may then be determined as indicated in Appendix 1, Figure 15.

Required nomographs and tables are contained in Appendix 1, Figures 16 and 17. An example pavement structure design can be found in Appendix 3.

19.06.06. GRAVEL ROAD DESIGN

The procedure accepted by Huerfano County for selection of base and sub-base thickness for gravel roads is based upon the AASHTO Guide for Design of Pavement Structures. Portions of this section including the tables and nomographs in Appendix 1, Figures 18, 19 and 20 are taken from that publication.

19.06.06.01. Factors

The allowable values for factors used in gravel road design are as follows:

- a. Allowable rutting, RD = 2 inches

**HUERFANO COUNTY
 ROADWAY DESIGN AND
 CONSTRUCTION
 STANDARDS
 SECTION 19.00**



- b. Gravel loss, GL = 2 inches
- c. Serviceability loss, ?PSI= 3.0
- d. Quality of roadbed soils for use in the table in 6.6.1 f shall be based upon HVEEM Stabilometer 11R" value as follows:

R < 15	Very Poor
R = 15 - 25	Poor
R = 25-35	Fair
R = 35-55	Good I
R > 55	Very Good I

- e. Season lengths, in number of months, shall be based upon U.S. climatic region VI, and are as follows:

Winter (roadbed frozen)	3.0 months
Spring thaw (roadbed saturated)	1.5 months
Summer ?(roadbed dry)	4.5 months
Spring/fall (roadbed wet)	3.0 months

- f. Seasonal roadbed soil resilient moduli, MR (psi), as a function of the relative quality of the road bed material shall be as follows:

Quality of roadbed soil	Season (<u>roadbed soil moisture condition</u>)			
	Summer	!Winter	Spring-thaw	Spring/fall
very good	20,000	2,500	8,000	20,000
good	20,000	2,000	6,000	10,000
fair	20,000	2,000	4,500	6,500
poor	20,000	1,500	3,300	4,900
very poor	20,000	1,500	2,500	4,000

19.06.06.02. Gravel Design Example

An example of a gravel roadway design is contained within Appendix 3, including text descriptions of the design steps in the AASHTO method.

**HUERFANO COUNTY
ROADWAY DESIGN AND
CONSTRUCTION
STANDARDS
SECTION 19.00**



19.07. ROADWAY ACCESS

19.07.01. AUTHORITY

Pursuant to Section 43-2-147(1), C.R.S., local governments are authorized to regulate vehicular access to and from any public roadway under their respective jurisdiction from or to property adjoining the roadway.

19.07.02. PURPOSE

It is the purpose of this section to provide the procedures and standards necessary to protect the public health, safety and welfare, to maintain smooth traffic flow, to maintain proper roadway drainage and to protect the functional level of the County road system while meeting state, regional, local and private transportation needs and interests.

19.07.03. IMPLEMENTATION

No person shall construct any access providing direct movement to or from any Huerfano County maintained roadway without an approved County access permit or a State Highway access permit when applicable. Huerfano County Road Access Permits shall be issued only in compliance with Section 19.07 of the Huerfano County Land Use Code. In no event shall an access be allowed or permitted if it is detrimental to the public health, safety or welfare.

State Highway permit application, permit instructions and the State Highway Access Code can be obtained from the [CDOT Website Access Permit Page](#).

Excerpt from the [State Highway Access Code](#):

Section 2.6 Changes in Land Use and Access Use

(1) It is the responsibility of the property owner and permittee to ensure that the use of the access to the property is not in violation of the Code, permit terms and conditions or the Act. The terms and conditions of any permit are binding upon all assigns, successor-in-interest, heirs and occupants. If any significant changes are made or will be made in the use of the property which will affect access operation, traffic volume and or vehicle type, the permittee or property owner shall contact the local issuing authority or the Department to determine if a new access permit and modifications to the access are required.

The State Highways within Huerfano County are comprised of SH12, SH160, SH10, SH69 and I-25.

**HUERFANO COUNTY
ROADWAY DESIGN AND
CONSTRUCTION
STANDARDS
SECTION 19.00**



19.07.04. APPLICATION FOR A PERMIT AND ISSUANCE OF PERMITS

19.07.04.01.

Persons wishing to apply for direct access to a County maintained roadway shall apply to the Road and Bridge Department on a standard form provided by the Department. In addition to the form, the Road and Bridge Department may require any or all of the following items:

- a. Site plan showing location of proposed access and proposed improvements. Plan shall show any existing access.
- b. Roadway and driveway plan and profile.
- c. Drainage plan of the site demonstrating mitigation of impact to the County roadway and drainage system.
- d. Any proposed improvements, modifications or structures within the County right-of-way.

19.07.04.02.

Upon receiving a complete application for an access permit, the Construction Inspector shall inspect the site and inform the applicant of the site specific requirements for construction of the access. Such requirements may include surface treatment of driveway, culvert or other drainage structures, width of access, etc.

19.07.04.03.

The actual access permit will not be finalized until construction of the access has been completed in accordance with the specifications of this Article and in compliance with the site specific requirements as determined by the Road and Bridge Department after field inspection.

19.07.04.04.

Construction of an access shall be complete and accepted by the County inspector before the access is used for its intended purpose. The permit will expire if construction is not completed within 6 months of application date. Re-application will be required.

19.07.05. ACCESS CONTROL STANDARDS

It is the policy of Huerfano County that private direct access to the public road system will be provided by way of the lowest classified road possible. For example, no private direct access shall be granted to a property from an arterial road when the property can be accessed from a collector or lower classified road. Similarly, no private direct access shall be granted to a property from a collector road when the property can be accessed from a local access

**HUERFANO COUNTY
ROADWAY DESIGN AND
CONSTRUCTION
STANDARDS
SECTION 19.00**



road.

Exceptions to this policy will be made only when it is demonstrated that a severe hardship would be caused the property owner by strict enforcement of the policy, a hardship arising from the unique circumstances or characteristics of the particular site.

19.07.05.01. Principal and Minor Arterials

When private direct access is allowed to an arterial road, the following restrictions shall apply:

- a. No more than one access approach shall be provided to an individual parcel or to contiguous parcels under the same ownership, unless it can be demonstrated that additional accesses would be beneficial to the safety and operation of the road system.
- b. On two lane arterials access approaches may be limited to only right-in and right-out turning movements if the access is within 500 feet of the nearest intersection.
- c. No access shall be permitted within 300 feet of a median opening unless the access is directly aligned with the median opening.
- d. No access configuration will be allowed that requires a vehicle to back out onto the roadway.

Intersections shall be spaced no less than one half mile apart on principal arterials and one quarter mile apart on minor arterials, unless such spacing is impractical or impossible due to topographic or other physical limitations.

19.07.05.02. Major Collectors

When private direct access is allowed to a major collector road, the following restrictions shall apply:

- a. No more than one access approach shall be provided to an individual parcel or to contiguous parcels under the same ownership, unless it can be demonstrated that additional accesses would be beneficial to the safety and operation of the road system.
- b. On two lane major collectors access approaches may be limited to only right-in and right-out turning movements if the access is within 500 feet of the nearest intersection.
- c. No access shall be permitted within 300 feet of a median opening unless the access is directly aligned with the median opening.
- d. No access configuration will be allowed that requires a vehicle to back out onto the roadway.

Huerfano County
Land Use Department
401 Main Street, Suite 304
Walsenburg, CO 81089
719-738-1220 x506

**HUERFANO COUNTY
ROADWAY DESIGN AND
CONSTRUCTION
STANDARDS
SECTION 19.00**



Major intersections--those with another collector or higher classified road--shall be spaced no less than one quarter mile apart on major collectors, unless such spacing is impractical or impossible due to topographic or other physical limitations. Spacing of public and private local access roads shall be no less than 300 feet.

19.07.05.03. Minor Collectors and Local Access Roads

Intersections shall be spaced no less than 150 feet apart unless such spacing is impractical or impossible due to topographic or other physical limitations.

19.07.06. CONSTRUCTION OF ACCESS

19.07.06.01.

The expected dates of construction and use of the access shall be included on the application for the permit. The applicant shall notify the Road and Bridge Department at least 72 hours prior to any construction within the County right-of-way.

19.07.06.02.

The Construction Inspector shall inspect the access during construction as needed and upon completion of construction to ensure that all terms and conditions of the permit application are met.

19.07.06.03.

The construction of the access and its appurtenances as required by the terms and conditions of the permit application shall be completed at the sole expense of the applicant. Huerfano County will not supply either materials or labor for the construction of the access and appurtenances.

19.07.06.04.

It is the responsibility of the applicant to complete the construction of the access according to the terms and conditions of the permit. The Road and Bridge Department may order a halt to any unauthorized construction or use of an access.

19.07.06.05.

All construction within the County right-of-way shall be performed only by a licensed, bonded, and insured contractor, pursuant to Huerfano County Resolution No. 06-024 As Amended.

19.07.06.06.

Adequate traffic control and construction signing in conformance with the most recent edition of the Manual on Uniform Traffic Control Devices is required at all times during construction of the access. All such traffic control and signing shall be at the applicant's expense and shall

Huerfano County
Land Use Department
401 Main Street, Suite 304
Walsenburg, CO 81089
719-738-1220 x506

**HUERFANO COUNTY
ROADWAY DESIGN AND
CONSTRUCTION
STANDARDS
SECTION 19.00**



not be provided by Huerfano County.

19.07.06.07.

The allowable hours of work within the County right-of-way may be restricted due to peak hour traffic demands, storm water flow, or other pertinent operating restrictions.

19.07.06.08.

All roadway access improvements including pavement, curbs, gutters, sidewalks, drainage structures, ditches and auxiliary lanes shall be within the County right-of-way. Any additional right-of-way required for such improvements must be dedicated or deeded to Huerfano County prior to construction beginning.

19.07.07. USE OF ACCESS

19.07.07.01.

It is the responsibility of the property owner to ensure that the use of the access is in compliance with this Section and all conditions and terms of the permit.

19.07.07.02.

Access permits are issued for a specific use or type of service. No change in the type of use or service (for instance from single family residential to commercial) may be made without the property owner applying for an amended access permit and securing approval from the Road and Bridge Department. Any change in the land use of the property served by the access which, in the opinion of the Road and Bridge Department, can be reasonably expected to result in a significant change in the volume or type of traffic using the access may necessitate issuance of a new or amended access permit.)

19.07.07.03.

Any access, whether constructed before, on, or after the date of adoption of these STANDARDS, may be required by the County to be reconstructed or relocated to conform to this Section, either at the property owner's expense if the reconstruction or relocation is necessitated by a change in the use of the property which results in a change in the type of access operation; or at the expense of the County if the reconstruction or relocation is necessitated by changes in road or traffic conditions.

19.07.08. ILLEGAL ACCESSES

For the purposes of these STANDARDS any access for which any of the following statements is true shall be considered an illegal access:

- a. The access was installed after the enactment of these STANDARDS without an access permit being applied for and issued.

**HUERFANO COUNTY
ROADWAY DESIGN AND
CONSTRUCTION
STANDARDS
SECTION 19.00**



b. The access was installed or is being used contrary to the terms and conditions of an access permit application or an approved access permit.

c. The land use of the property or the type of the service for which the access is being used has changed significantly since these STANDARDS were enacted without an access permit or amended permit being granted.

19.07.08.01. Policy for Correcting Illegal Accesses

Upon discovery of an access considered illegal under the terms of this section, the Road and Bridge Department will send written notice to the property owner. The notice will be sent via certified mail, return receipt requested, to the last known address of the owner as shown in the records of the County Assessor's Office. Such notice will include a description of all steps necessary to bring the access into compliance. If the property owner fails to bring the access into compliance within 30 days of the written notice the Road and Bridge Department may, at its option, install barriers across the access or remove the access.

19.07.09. DRAINAGE

The roadway drainage system is for the protection of the Huerfano County roadway and right-of-way. It is not designed or intended to serve the drainage requirements of abutting properties beyond the levels which have historically flowed to the County right-of-way. Drainage to the County right-of-way shall not exceed the undeveloped historical flow.

19.07.09.01.

Drainage structures constructed as part of an access shall not restrict or obstruct the existing drainage system, and shall be in accordance with approved drainage plans or studies where applicable. Culverts shall be a minimum of 18 inches in diameter and Annular CMP. Length, diameter, cover, type, and inlet and outlet elevation of all culverts is subject to approval of the Road and Bridge Department.

19.07.09.02.

Accesses shall be constructed in such a manner that does not cause erosion and will not result in deposition of silt and debris upon the County roadway. Accesses which slope down toward the public road will be constructed to include suitable means of assuring water does not run onto or across the traveled public way. This may include crown, borrow ditches, pans, etc. along the access sufficient to direct water to the existing drainage facilities along the public road.

19.07.010. DRIVEWAYS

**HUERFANO COUNTY
ROADWAY DESIGN AND
CONSTRUCTION
STANDARDS
SECTION 19.00**



19.07.010.01. Geometric Standards

Driveways shall conform to the geometric standards illustrated in Appendix 1, Figures 21 through 23. Any variation from the requirements shown due to physical site restrictions or unusual circumstances must be approved by the Board of County Commissioners.

19.07.010.02. Location

Location of driveways shall be in accordance with Figure 24 in Appendix 1

19.07.010.03. Miscellaneous Requirements

- a. Only one residential access per lot or parcel will be allowed unless lot frontage is of sufficient width to allow a minimum spacing of 50 feet between driveways on one parcel or lot.
- b. If the road which will be accessed is paved, the Applicant shall pave the full width of the driveway access from the edge of the roadway asphalt a distance toward the property line which is the largest of any of the following which apply:
 1. Top of the borrow ditch bank on the property line side of the ditch.
 2. Back of sidewalk.
 3. High point of driveway swale on the property line side of the driveway swale.

In no case will the driveway paving extend less than 5 feet from the edge of the roadway asphalt. The minimum depth of asphalt paving shall be two lifts of two inches each of grade C or CX hot bituminous paving. The paving shall be placed on top of a minimum 6 inches of class 6 aggregate base course material which has been compacted to 95% standard Proctor density.

- c. If the road which will be accessed is not paved, the driveway shall be constructed with class 6 aggregate base course material a minimum of 9 inches in depth from the edge of the road to the property line.
- d. If an unlined drainage ditch exists along the road to be accessed, the Applicant must supply and install a culvert pipe in the driveway. The length and diameter of the pipe shall be as determined by the Road and Bridge Department, but in no case shall the pipe be smaller than 18 inches in diameter nor less than 20 feet in length. The pipe will be bedded with a minimum of 6 inches of class 6 aggregate base course material with a minimum of 1 foot of cover over the pipe, compacted to 95% standard Proctor density. A swaled access is a permissible alternative assuming all other conditions are met, at the discretion of the Road and Bridge Department.

**HUERFANO COUNTY
ROADWAY DESIGN AND
CONSTRUCTION
STANDARDS
SECTION 19.00**



e. Culvert pipes shall be given one of the following end treatments at both the inlet and outlet ends at the discretion of the Inspector:

- * Concrete slope paving--see Figure 25 in Appendix 1.
- * Concrete headwall--see Figure 26 in Appendix 1.

19.07.011. DRIVEWAY LOCATION LIMITATIONS

A NEW driveway access will not be allowed:

1. Within 10 feet of any commercial property line except when it is a joint-use driveway serving two abutting commercial properties and access agreements have been exchanged between, and recorded by, the two abutting property owners;
2. When the total width of all driveways, existing and proposed, serving a given property would exceed 50% of the curb line frontage where such frontage is 100 feet or less;
3. Within 50 feet of the right-of-way line of an intersecting non-arterial road;
4. Within 100 feet of the tight-of-way line of an intersecting arterial road;
5. Within 100 feet of an approved median opening location on an arterial road;
6. Within 25 feet of a guardrail ending;
7. Within 100 feet of a bridge structure;
8. Within the minimum spacing as established by Figure 24 in Appendix I; or,
9. When adequate sight distance cannot be provided to vehicles on the driveway attempting to access the road.

Exceptions may be made by the Board of County Commissioners where the application of these standards would create undue hardship to the abutting property owners.

19.07.012. SPEED CHANGE LANES

Speed change lanes for right turning movements are required for any access (including public and private roads, driveways, etc.) based upon posted speed limits and traffic volumes according to the warrants listed in the following table.

Huerfano County
 Land Use Department
 401 Main Street, Suite 304
 Walsenburg, CO 81089
 719-738-1220 x506

**HUERFANO COUNTY
 ROADWAY DESIGN AND
 CONSTRUCTION
 STANDARDS
 SECTION 19.00**



RIGHT TURN LANE WARRANTS					
Posted Speed of Main Road in MPH					
	25	30 to 40	45 to 50	55	For a
If the DHV of the main road is	500	400	200	150	2 lane road
	1400	1200	800	600	4 or more lanes
DHV/ADT (DESIGN HOUR VOLUME/AVERAGE DAILY TRAFFIC)					
and the DHV or ADT of the access or minor Road is	50/140	0/350	20/175	15/150	2 lane road
	70/625	60/550	40/350	25/225	4 or more lanes
a) For roads with four travel lanes, DHV values of the main road will be only in the direction of the access approach.					
b) A right turn acceleration lane is not required if the posted speed is 40 mph or less, nor at a signalized intersection.					

**HUERFANO COUNTY
 ROADWAY DESIGN AND
 CONSTRUCTION
 STANDARDS
 SECTION 19.00**



When required, speed change lanes for right turning movements shall be constructed in accordance with the following figure and table:

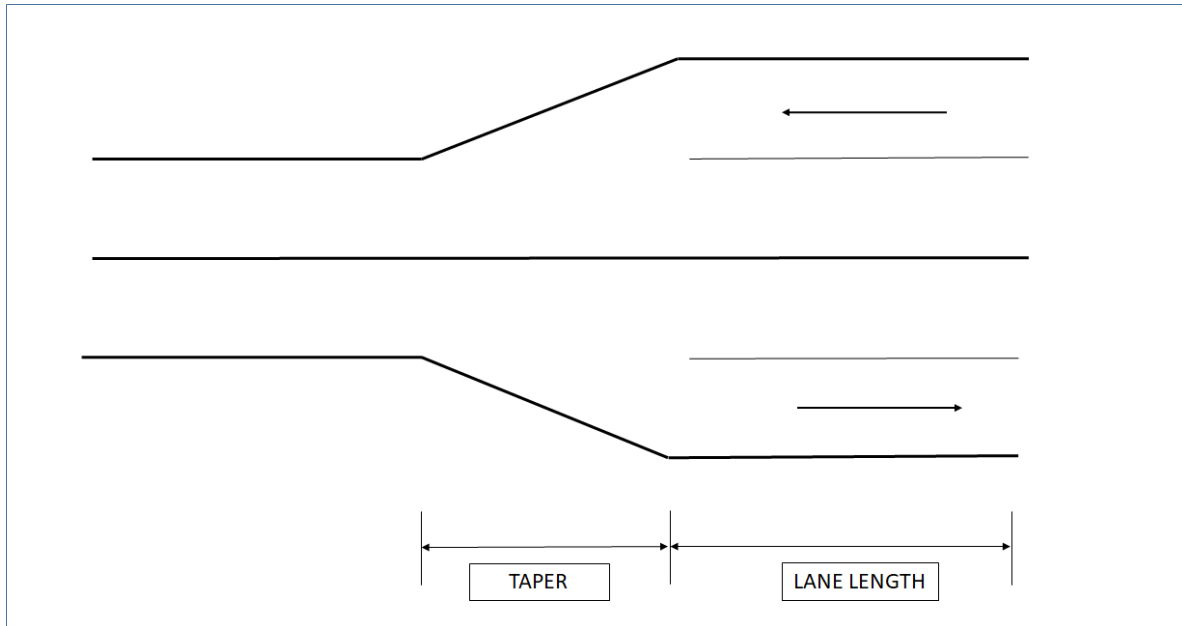

RIGHT TURN LANE				
	Acceleration Lane		Deceleration Lane	
Posted Speed	Lane Length	Taper	Lane Length	Taper
30	90	100	105	80
35	165	125	130	105
40	200	180	150	140
45	270	210	190	160
50	440	240	225	180
55	500	300	250	240

Speed change lanes for left turning movements are required for any access (including public and private roads, driveways, etc.) based upon posted speed limits and traffic volumes according to the warrants listed in the following table.

**HUERFANO COUNTY
 ROADWAY DESIGN AND
 CONSTRUCTION
 STANDARDS
 SECTION 19.00**



LEFT TURN LANE WARRANTS					
Posted Speed of Main Road in MPH					
	25	30 to 40	45 to 50	55	For a
If the DHV of the main road is	500 1000	400 900	200 600	150 400	2 lane road 4 or more lanes
DHV/ADT					
and the DHV or ADT of the access or minor road is	30/250 45/375	20/175 30/250	15/125 20/175	12/100 12/100	2 lane road 4 or more lanes
a) For roads with four travel lanes, DHV values of the main road will be only in the direction of the access approach.					
b) A right turn acceleration lane is not required if the posted speed is 40 mph or less, nor at a signalized intersection.					

When required, speed change lanes for left turning movements shall be constructed in accordance with the following figure and table:

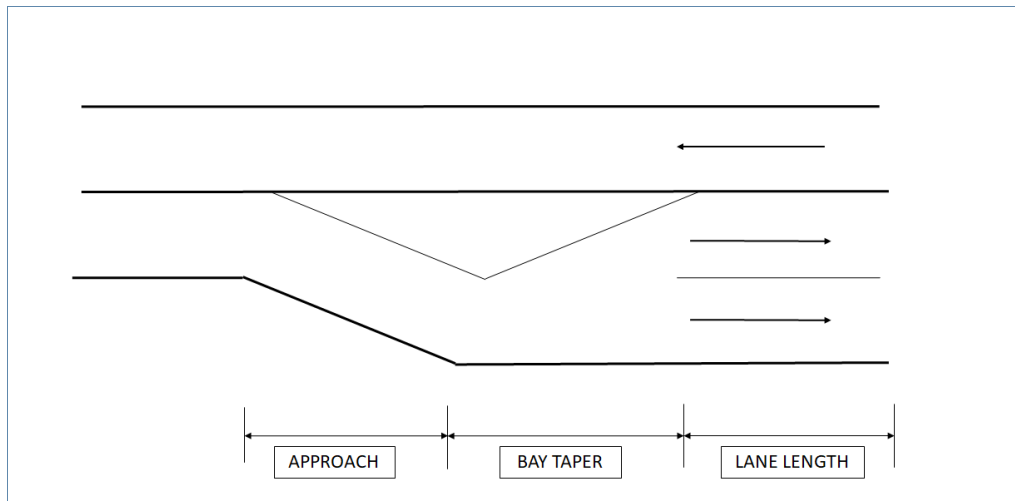

**HUERFANO COUNTY
 ROADWAY DESIGN AND
 CONSTRUCTION
 STANDARDS
 SECTION 19.00**



LEFT TURN LANE			
Posted Speed	Approach Taper	Bay Taper	Lane Length
30	280	100	135
35	350	125	150
40	420	150	165
50	630	200	235
55	700	250	250

For use of the above figures and tables and the design of speed change lanes, the following notes apply:

- Minimum width of speed change lanes shall be 12 feet, exclusive of shoulder.
- The design hour volume, DHV, shall be considered the average peak hour volume.
- Applicants for residential accesses serving more than 10 dwelling units, commercial accesses, and industrial accesses shall submit a traffic study which includes estimates of the volume and type of traffic to be using the access at build-out, turning movements into and out of the access, the effect of the proposed access on the existing traffic on the public road to be accessed, and any other information deemed by the Road and Bridge Department to be necessary to evaluate the specific site requirements.
- The lengths shown for speed change lanes are minimum lengths which may need to be increased due to grade, sight distance, topography, etc. For grades of 3 percent or more the lane length shall be increased in accordance with the factors contained in the Colorado Department of Transportation's Roadway Design Manual.
- For deceleration lanes where vehicle turning movements are 30 DHV or more, additional storage length is required according to the following:

DHV of Deceleration Lane	Additional Storage Length
30	25
60	50
100	100
200	175
300	250

Huerfano County
Land Use Department
401 Main Street, Suite 304
Walsenburg, CO 81089
719-738-1220 x506

**HUERFANO COUNTY
ROADWAY DESIGN AND
CONSTRUCTION
STANDARDS
SECTION 19.00**



19.07.013. APPLICATION FEES

Minimum administrative and inspection fees shall be charged to the applicant for any access permit. The fee is intended to cover the actual cost incurred by the County in administration of the permit and inspection of the proposed location of the access and construction of the access for compliance with the standards outlined in this policy.

19.07.013.01.

The minimum permit fee for an access permit shall be as adopted by resolution of the Board of County Commissioners:

Type of Access (based on use)	Fee
Residential	\$100.00
Agricultural	\$100.00
Commercial	\$150.00
Industrial	\$150.00

19.07.013.02.

The minimum application fees are due and payable at the time of application and prior to the issuance of any permit.

19.07.013.03.

In addition to the minimum fees, the applicant will be billed for additional costs incurred by the County as a result of the applicant's failure to comply with the conditions and terms of an access permit application or the requirements for notification prior to construction as stated herein. The additional costs will be based upon the actual time spent by the Construction Inspector or other designated representative in inspecting the construction of the access when more than the initial field inspection of the construction is required due to the failure of the applicant or their hired contractor to comply with the requirements and specifications of this policy. The actual cost will be determined based upon the actual time spent in such additional inspections, including travel time, multiplied times the loaded wage rate for the inspector involved.

19.07.014. DAMAGE TO COUNTY ROADWAY AND IMPROVEMENTS

Any damage to the pre-existing County roadway, drainage ways, structures, traffic control devices, etc. within the County right-of-way arising from or occurring during the construction of the roadway access, or performed on the property served in connection with the use for which the permit is applied, shall be promptly repaired by the applicant prior to the final issuance of the permit. All debris, rubble, excess material, etc. will be removed from the County right-of-way.

Huerfano County
Land Use Department
401 Main Street, Suite 304
Walsenburg, CO 81089
719-738-1220 x506

**HUERFANO COUNTY
ROADWAY DESIGN AND
CONSTRUCTION
STANDARDS
SECTION 19.00**



19.07.014.01. Nuisances

- A. Intentionally or unintentionally causing a County Road to become damaged, blocked, partially blocked, or otherwise impassable shall be considered a nuisance and the responsible party will be charged an impact fee and other fees allowed by law. and will be assessed for the cost of damage.
- B. Creating obstructions or hazards in the right-of-way may be subject to prosecution under CRS 43-5-301

Huerfano County
Land Use Department
401 Main Street, Suite 304
Walsenburg, CO 81089
719-738-1220 x506

**HUERFANO COUNTY
ROADWAY DESIGN AND
CONSTRUCTION
STANDARDS
SECTION 19.00**



19.08. CONSTRUCTION SPECIFICATIONS

19.08.01. GENERAL POLICIES

For the purposes of this Section, "work" shall be defined as the providing of labor, materials and equipment necessary for the completion of the construction, re-construction, repair, modification or relocation of road, drainage, traffic control, utility and other structures, appurtenances, or improvements within the right-of-way or related easements as required by a land use approval or allowed by an access or excavation permit.

Huerfano County and Colorado Department of Transportation Construction Specifications.

During the execution of the work, all materials, performance, and quality of work shall conform to the requirements of these STANDARDS and the most recent edition of the Colorado Department of Transportation's Standard Specifications for Road and Bridge Construction.

Specific modifications to the CDOT Specifications are made within this Section.

If these STANDARDS or the CDOT Specifications do not cover a specific situation during the course of work, applicable specifications must be approved by or obtained from the Board of County Commissioners. The Board of County Commissioners shall be the final authority on the meaning or interpretation of all specifications. In the event of a conflict between these STANDARDS and CDOT Specifications, these STANDARDS shall control.

19.08.02. CONTROL OF WORK

All work done within County road right-of-way and applicable work done on private property shall be inspected and documented by Huerfano County to ensure compliance with these STANDARDS, the approved plans, and any subdivision improvements agreement. The Huerfano County Road and Bridge Department shall have the authority to control work as determined by these STANDARDS, decide all questions which may arise as to the quality and acceptability of materials furnished or the work performed, or as to the rate of progress of the work, and to decide all questions as to the interpretation of the approved plans.

The Road and Bridge Department shall, in writing, suspend the work in whole or in part due to the failure of the contractor to correct conditions unsafe for the general public; for failure to carry out provisions of these STANDARDS and approved plans; for failure to carry out written or verbal orders as a result of unsatisfactory work found during inspections; for periods of time due to unsuitable weather conditions; for conditions considered unsuitable for the proper execution of the work; or for any other condition or reason deemed to be in the public interest or to protect the public health, safety and welfare.

**HUERFANO COUNTY
ROADWAY DESIGN AND
CONSTRUCTION
STANDARDS
SECTION 19.00**



19.08.03. AUTHORITY OF THE INSPECTOR

The Road and Bridge Department shall be represented by the Construction Inspector, or other official as designated by the Board of County Commissioners, who is authorized to inspect all work done and materials furnished. The inspector shall not be authorized to waive any provisions of these STANDARDS or the approved plans, nor to issue instructions contrary to these STANDARDS or the approved plans. The inspector shall not act as a foreman for the contractor nor supervise or direct the work.

19.08.04. THE PROJECT ENGINEER

The Project Engineer shall be the duly authorized agent of the developer and/or the contractor and has immediate charge of the engineering details of the work. It shall be the responsibility of the Project Engineer:

- a. To provide to the Construction Inspector any engineering details, documentation, or any other information regarding the prosecution of the work.
- b. To provide to the Road and Bridge Department, for written approval, any proposed alterations to the approved plans and specifications before any such modifications are incorporated into the work.
- c. To provide "as-built" plans to the Road and Bridge Department upon completion of all work to be performed on the project as a condition of final approval of the work.
- d. To furnish and set construction stakes and marks establishing all lines, grades and measurements necessary to the proper execution of the work in its final location as shown on the approved plans.

19.08.05. INSPECTION AND TESTING

To ensure compliance with these STANDARDS and the approved plans, adequate in-progress inspection and testing is required.

All materials and each part or detail of the work shall be subject to the inspection of the Construction Inspector. The Construction Inspector shall be allowed access to all parts of the work and shall be furnished with such information and assistance by the Project Engineer and Contractor as required to make a complete and detailed inspection.

When the construction specifications of other jurisdictions (such as water or sewer districts) are used to govern a portion of the work or are included within the approved plans, written

Huerfano County
Land Use Department
401 Main Street, Suite 304
Walsenburg, CO 81089
719-738-1220 x506

**HUERFANO COUNTY
ROADWAY DESIGN AND
CONSTRUCTION
STANDARDS
SECTION 19.00**



approval shall be provided by the other jurisdictions and made available to the Construction Inspector prior to final acceptance of the work. Regular in-progress materials testing shall be provided to the Construction Inspector in a timely manner during the course of the work, and shall be a requirement of final acceptance. The interval of in-progress materials testing shall conform to the most current testing schedule established by the Colorado Department of Transportation, Materials Testing Section. The number of tests and their location are subject to approval of the Construction Inspector. All materials testing shall be performed by an independent laboratory under the supervision of a Colorado licensed professional engineer at the expense of the developer, Project Engineer or Contractor. Huerfano County may at its option perform such additional quality control testing as it deems appropriate and necessary or desirable at its own expense.

Any work done or materials used without inspection or testing may be ordered removed or replaced. The Construction Inspector may, at any time before acceptance of the work, direct the contractor to remove or uncover any portion of the finished work. After examination, and after approval of the work by the Construction Inspector, the Contractor shall restore the portions of the work disturbed to the standard required by the plans and specifications.

19.08.06. REMOVAL OF UNACCEPTABLE OR UNAUTHORIZED WORK

All work which does not conform to these STANDARDS and the approved plans shall be considered unacceptable work, whether the result of poor workmanship, use of defective materials, damage through carelessness or any other cause found to exist prior to final acceptance of the work. Unacceptable work shall be removed and replaced according to these STANDARDS prior to acceptance of the work.

Work shall not be done without lines and grades per Section 19.08.04 of this Section. Any work done contrary to the instructions of the Project Engineer or Construction Inspector shall be considered unauthorized and may be ordered removed.

19.08.07. USE OF APPROVED PLANS AND SPECIFICATIONS

Any work performed without approved (record set) plans and specifications shall be considered unauthorized and may be ordered removed and the prior existing conditions restored.

The approved plans, specifications, supplementary specifications, standards, supplementary standards and any special provision required or approved by the County shall be considered complimentary to describe and provide for complete work.

The Contractor shall not take advantage of any error or omission in the approved plans, standards and specifications. In the event an apparent error or omission is discovered, the Project

Huerfano County
Land Use Department
401 Main Street, Suite 304
Walsenburg, CO 81089
719-738-1220 x506

**HUERFANO COUNTY
ROADWAY DESIGN AND
CONSTRUCTION
STANDARDS
SECTION 19.00**



Engineer and the Construction Inspector shall be notified. The Project Engineer shall make corrections required, subject to approval by the Board of County Commissioners.

19.08.08. FINAL ACCEPTANCE

Upon written notice from the developer of the completion of all work, the Construction Inspector shall make a final inspection. If all construction provided for in the approved plans, performance guarantee and/or subdivision improvement agreement is found by the Board of County Commissioners to be satisfactory, the procedure for acceptance by the Board of County Commissioners for maintenance or release of the performance guarantee may be initiated. If, however, the inspection discloses any work in whole or in part as being unsatisfactory or incomplete, the County shall notify the developer in writing of the deficient items. In the event the work is not complete, the developer is responsible for maintenance of the work until such time as all such items are completed or corrected and a re-inspection has been made.

19.08.09. MODIFICATIONS TO CDOT SPECIFICATIONS

The following modifications or additions are made to the Colorado Department of Transportation's Standard Specifications for Road and Bridge Construction. These modifications and additions shall apply to all work covered under these STANDARDS.

a. Class 6 aggregate base course material shall be crushed material, with at least 50 per cent of the material remaining upon the #4 sieve having at least two fractured faces. No slag based Class 6 aggregate base course material will be allowed as a final surface treatment. Slag based Class 6 aggregate base course will be acceptable for base material under a final asphalt or concrete paving course.

b. Aggregate for Hot Bituminous Paving shall conform to the following:

Grading C--50 percent of the material passing through the 3/4-inch sieve and retained upon the # 4 sieve shall have a minimum of two fractured faces.

Grading CX--50 per cent of the material passing through the 1/2-inch sieve and retained upon the # 4 sieve shall have a minimum of two fractured faces.

c. Bon-ow material--All borrow material used within the right-of-way shall meet the following requirements and be subject to approval of the Board of County Commissioners:

All borrow material shall be non-organic, and contain no trash or perishables nor particles exceeding 4 inches in size, and shall have a minimum dry density of 90 lbs./cu. ft.

**HUERFANO COUNTY
 ROADWAY DESIGN AND
 CONSTRUCTION
 STANDARDS
 SECTION 19.00**



All borrow material shall consist of material which is essentially a granular soil with a minimum "R" value of 40, a maximum liquid limit of 30, a maximum plasticity index of 6, and the following grain size distribution:

Sieve Designation	% Passing
4 inch	100
#200	3-20

d. Culvert pipe--All culvert pipe installed within the public right-of-way shall conform to one of the following:

Corrugated steel pipe--16 gauge or heavier, annular, in compliance with AASHTO designation M 36.

e. Aggregate base course material for final surface of gravel roads shall have a maximum liquid limit of 25, a plasticity index of 6 or less, and shall consist of a crushed naturally occurring rock material (no slag) with at least 50 per cent of the material remaining on the # 4 sieve having at least two fractured faces. In addition, the material will meet the following gradation:

Sieve Designation	% Passing
1"	100
1/2"	75 -- 85
no.4	30 -- 65
no. 8	25 -- 55
no.200	12 -- 18

All other CDOT specifications for aggregate base course not modified above shall apply.

Huerfano County
Land Use Department
401 Main Street, Suite 304
Walsenburg, CO 81089
719-738-1220 x506

**HUERFANO COUNTY
ROADWAY DESIGN AND
CONSTRUCTION
STANDARDS
SECTION 19.00**



19.09. CATTLE GUARDS ON PUBLIC ROADWAYS

19.09.01. DEFINITION.

Colorado Revised Statute 43-2-211 Cattle guards - specifications. The board of county commissioners of a county has authority to establish cattle guards on highways at the expense of the county or to permit the owners of land adjoining a county highway to establish cattle guards on highways at the expense of the landowners. All such cattle guards shall be established according to fixed specifications and design and under the supervision of the board of county commissioners.

Note: Alternate specifications and design, as well as, cost may be reviewed or modified by the Board of County Commissioners from time to time.

19.09.02. REQUEST FOR INSTALLATION.

The request for a cattle guard shall be reviewed on a case by case basis. No person shall be entitled to installation of a cattle guard in a county road. In determining whether to install a cattle guard, the Huerfano County Road & Bridge Department shall consider the circumstances at the requested cattle guard site, including but not limited to number and location of other existing cattle guards, convenience of location for future county maintenance, weather and wind conditions at the site, condition of relevant fencing and other appropriate factors.

If the request for installation of a new cattle guard is approved, the requesting party shall pay \$3,500.00 to Huerfano County for the cattle guard and installation. Once installed the cattle guard shall become the property of Huerfano County who shall be responsible for perpetual maintenance.

If all attending facts and circumstances justify the waiver of all or a portion of the cost of the cattle guard, base, and installation, the requesting party may apply to the Board of County Commissioners and request a waiver of all or a portion of the costs and fees. The decision of the Board of County Commissioners shall be a final decision. No waiver granted to any landowner shall constitute precedent or expectation of future waivers to other landowners. Each waiver request shall be considered based on the facts and circumstances in existence regarding the particular site for which the waiver was requested.

19.09.03. MAINTENANCE AND REMOVAL.

Huerfano County, acting by and through Huerfano County Road and Bridge Department, shall own and maintain all existing cattle guards located on and across county roadways until such time as any

Huerfano County
Land Use Department
401 Main Street, Suite 304
Walsenburg, CO 81089
719-738-1220 x506

**HUERFANO COUNTY
ROADWAY DESIGN AND
CONSTRUCTION
STANDARDS
SECTION 19.00**



such cattle guard is no longer required. The determination as to whether or not a particular cattle guard is no longer required shall be left to the discretion of the adjacent property owners. Where it is determined that a particular cattle guard is no longer required, it shall then be removed by Huerfano County and either junked, stored for further use, or used to replace other cattle guards located on or across county roadways is deemed appropriate by Huerfano County. (Res. 06-24 As Amended)

19.09.04. CATTLE GUARD CONSTRUCTION--COUNTY SPECIFICATIONS TO BE MET.

A party requesting that a cattle guard be established at a location not presently served by a cattle guard must fund the entire cost of the construction and installation of an approved cattle guard. Each approved cattle guard must be constructed and installed by a licensed, bonded and insured excavator in accordance with the county's existing excavation permit regulations. Huerfano County shall provide a standard for cattle guard construction to the person desiring to establish an approved cattle guard (*reference Colorado Department of Transportation M-61 I, pages 1 & 2: 2-7/8" drill stem may be substituted/or the S4x7. 7 and C4x7.25 beams as shown*). During the construction and installation process, Huerfano County shall inspect the construction and installation of the cattle guard to insure it is being constructed and installed in accordance with county specifications before it shall be considered an approved cattle guard. Following the construction and installation of a cattle guard, Huerfano County must accept the cattle guard as being constructed and installed in accordance with county specifications before it shall be considered an approved cattle guard.

(Res. 06-24 As Amended)

19.09.05. COUNTY RESPONSIBLE AFTER APPROVAL.

Following approval of a cattle guard by Huerfano County, Huerfano County shall be responsible for perpetually maintaining the cattle guard. In no event, shall Huerfano County be responsible for the maintenance of a cattle guard until such time as the cattle guard has been approved by Huerfano County as being constructed and installed in accordance with county specifications. (Res. 06-24 As Amended)

19.09.06. REPLACEMENT, ABANDONMENT OR DISCONTINUANCE BY COUNTY.

In the event any cattle guard located upon any County road is deemed by the County to be beyond repair, the cattle guard shall be replaced. The County shall pay for the entire cost of said replacement. Nothing contained in this Section shall limit or restrict the right of Huerfano County to discontinue or limit maintenance of a particular cattle guard or the highway upon which it is situated, or to abandon or vacate any such roadway according to law, where such action is deemed to be in the public interest by the Board of County Commissioners of Huerfano County, Colorado.

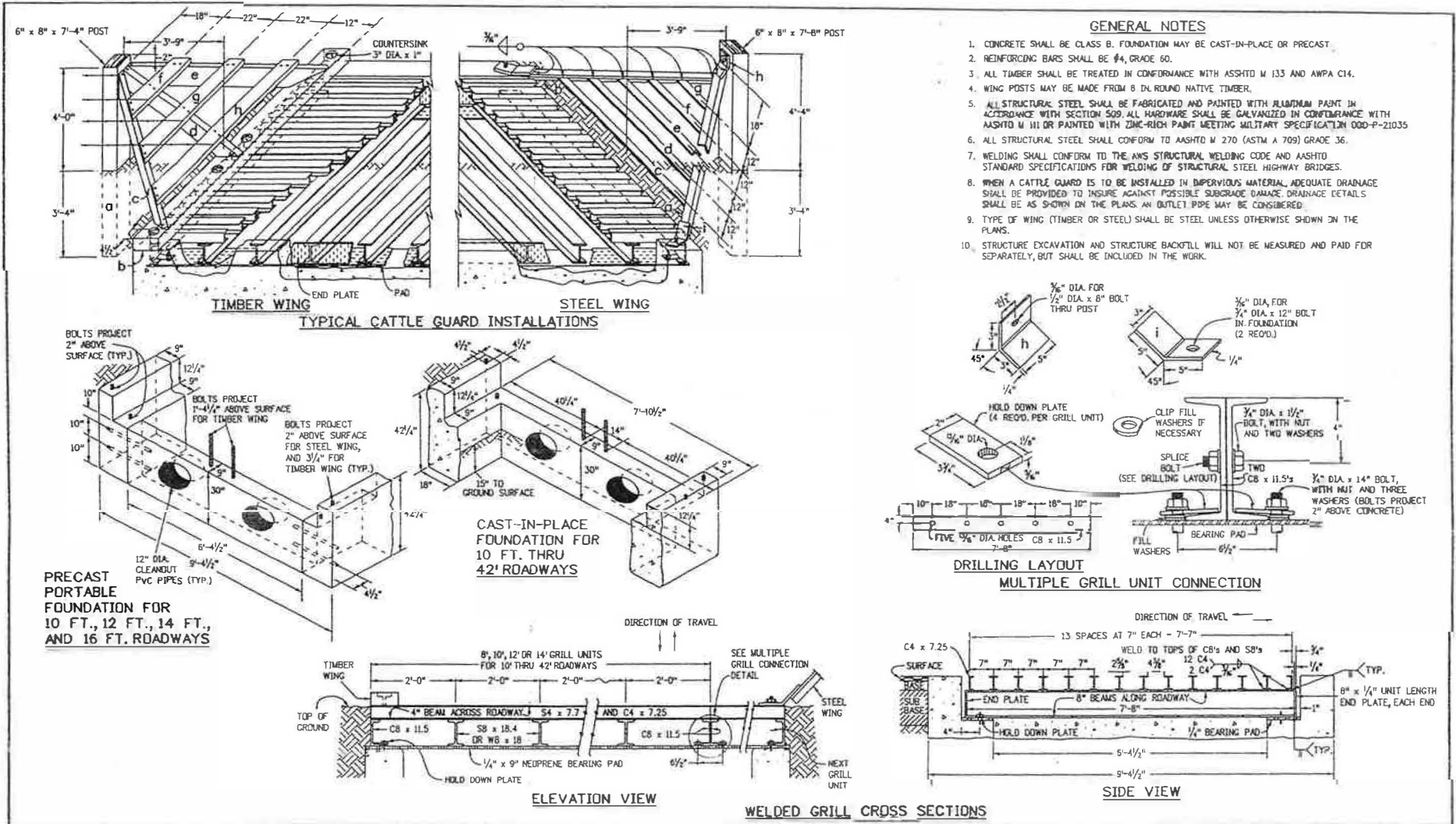

GENERAL NOTES

1. CONCRETE SHALL BE CLASS B. FOUNDATION MAY BE CAST-IN-PLACE OR PRECAST.
2. REINFORCING BARS SHALL BE #4, GRADE 60.
3. ALL TIMBER SHALL BE TREATED IN CONFORMANCE WITH AASHTO M 133 AND ANPA C14.
4. WING POSTS MAY BE MADE FROM 8 DL ROUND NATIVE TIMBER.
5. ALL STRUCTURAL STEEL SHALL BE FABRICATED AND PAINTED WITH ALUMINUM PAINT IN ACCORDANCE WITH SECTION 509. ALL HARDWARE SHALL BE GALVANIZED IN CONFORMANCE WITH AASHTO M 111 OR PAINTED WITH ZINC-RICH PAINT MEETING MILITARY SPECIFICATION DDG-P-21035
6. ALL STRUCTURAL STEEL SHALL CONFORM TO AASHTO M 270 (ASTM A 709) GRADE 36.
7. WELDING SHALL CONFORM TO THE AWS STRUCTURAL WELDING CODE AND AASHTO STANDARD SPECIFICATIONS FOR WELDING OF STRUCTURAL STEEL HIGHWAY BRIDGES.
8. WHEN A CATTLE GUARD IS TO BE INSTALLED IN IMPERVIOUS MATERIAL, ADEQUATE DRAINAGE SHALL BE PROVIDED TO INSURE AGAINST POSSIBLE SUBGRADE DAMAGE. DRAINAGE DETAILS SHALL BE AS SHOWN ON THE PLANS. AN OUTLET PIPE MAY BE CONSIDERED.
9. TYPE OF WING (TIMBER OR STEEL) SHALL BE STEEL UNLESS OTHERWISE SHOWN ON THE PLANS.
10. STRUCTURE EXCAVATION AND STRUCTURE BACKFILL WILL NOT BE MEASURED AND PAID FOR SEPARATELY, BUT SHALL BE INCLUDED IN THE WORK.

Computer File Information

Creation Date: 07/04/12	Initials: DD
Revision Date: 07/04/12	Initials: DD
File Name: 61101D102.dwg	

Sheet Revisions

Date:	Comments:

Colorado Department of Transportation
 4201 East Arkansas Avenue
 Denver, Colorado 80222
 Phone: (303) 757-9000
 Fax: (303) 757-9820

Project Development Branch DD/LTA

CATTLE GUARD

Issued By: Project Development Branch July 4, 2012

STANDARD PLAN NO.

M-611-1

Sheet No. 1 of 2

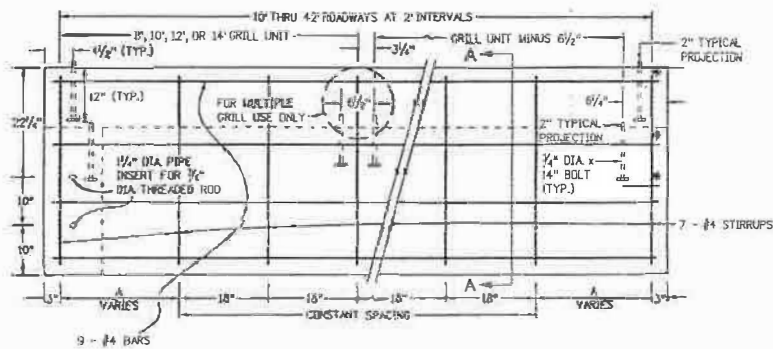

PRECAST PORTABLE FOUNDATION

CAST-IN-PLACE FOUNDATION

ELEVATION OF FOUNDATION

* WHEN CAST IN PLACE,
LONGITUDINAL BARS EXTENDING
FROM AND INTO THE LATERAL
SUPPORT SHALL BE BENT 90°
WITH A 2 IN. RADIUS AND
CONTINUE PERPENDICULAR
30 IN. FROM THE BEND

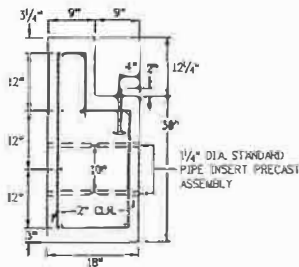

**END SECTION OF FOUNDATION
SECTION A-A**

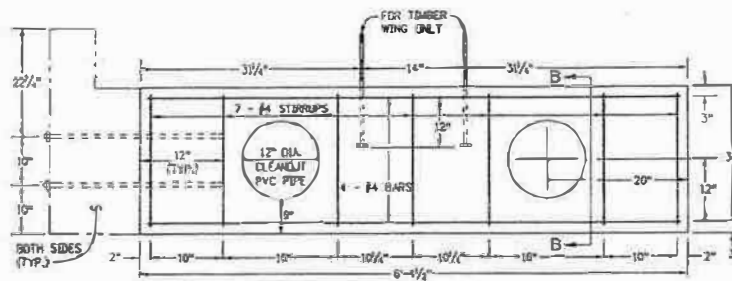

ELEVATION OF LATERAL SUPPORT

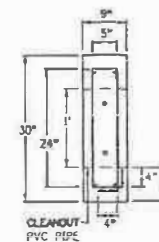

**LATERAL SUPPORT
SECTION B-B**

a - 6" x 8" x 7'-4"
b - 4" x 6" x 5'-4 1/2"
c - 2" x 6" x 5'-7"
d - 2" x 6" x 5'-8"
e - 2" x 6" x 6'-7"
f - 2" x 6" x 2'-5"
g - 2" x 6" x 4'-4"
h - 2" x 6" x 5'-2"
16d NAILS (GALV.) - 2 LBS.

ONE TIMBER WING

a - 2" x 2" x 1/4" x 79"
b - 2" x 2" x 1/4" x 79"
c - 2" x 2" x 1/4" x 64"
d - 1 1/2" x 1 1/2" x 1/4" x 69"
e - 1 1/2" x 1 1/2" x 1/4" x 55"
f - 1 1/2" x 1 1/2" x 1/4" x 40"
g - 1 1/2" x 1 1/2" x 1/4" x 25"
h - 5" x 6" x 1/4" x BAR - 2.13 LBS.
i - TWO 3" x 10" x 1/4" x BARS - 4.25 LBS.
6" x 8" x 7'-6" TIMBER POST
TOTAL LBS. STEEL = ~106.5

**ONE STEEL WING
WING QUANTITIES**

ROADWAY WIDTH (FT.)	USE GRILL UNITS (FT.)	PRECAST		CAST-IN-PLACE		A (IN.)	TOTAL GRILL WEIGHT (LBS.)
		CONCRETE (CU. YD.)	REINF. STEEL (LBS.)	CONCRETE (CU. YD.)	REINF. STEEL (LBS.)		
10	10	5.6	295	5.6	308	24	1946
12	12	8.5	342	6.5	364	18	2326
14	14	7.4	378	7.4	399	21	2170
16	8 0	8.1	414	8.1	435	24	3126
18	8 10			9.0	482	18	3434
20	10 10			9.8	518	21	3506
22	10 12			10.6	553	24	4274
24	12 12			11.5	601	18	4656
26	12 14			12.3	636	21	5036
28	14 14			13.1	672	24	5420
30	10 10 10			13.9	719	18	5839
32	10 12 10			14.6	755	21	6223
34	12 10 12			15.5	790	24	6602
36	12 12 12			16.4	838	18	6984
38	12 14 12			17.3	873	21	7366
40	14 12 14			18.0	909	24	7748
42	14 14 14			18.9	956	18	8130

FOUNDATION QUANTITIES

SIZE	WEIGHT (LBS.)
8"	1564
10"	1946
12"	2326
14"	2710

WELDED GRILL UNITS

Computer File Information Creation Date: 07/04/12 Initials: DD Last Modification Date: 07/04/12 Initials: LTA Full Path: www.coloradodot.info/business/designsupport Drawing File Name: 611010202.dgn CAD Ver.: MicroStation V8 Scale: Not to Scale Units: English		Sheet Revisions <table border="1"> <thead> <tr> <th>Date:</th> <th>Comments:</th> </tr> </thead> <tbody> <tr><td>(R-C)</td><td></td></tr> <tr><td>(R-C)</td><td></td></tr> <tr><td>(R-C)</td><td></td></tr> </tbody> </table>		Date:	Comments:	(R-C)		(R-C)		(R-C)		Colorado Department of Transportation 4201 East Arkansas Avenue Denver, Colorado 80222 Phone: (303) 757-9063 Fax: (303) 757-9820 Project Development Branch DD/LTA		CATTLE GUARD Issued By: Project Development Branch July 4, 2012		STANDARD PLAN NO. M-611-1 Sheet No. 2 of 2	
Date:	Comments:																
(R-C)																	
(R-C)																	
(R-C)																	

Huerfano County
Land Use Department
401 Main Street, Suite 304
Walsenburg, CO 81089
719-738-1220 x506

**HUERFANO COUNTY
ROADWAY DESIGN AND
CONSTRUCTION
STANDARDS
SECTION 19.00**



19.010. EXCAVATIONS & R.O.W. OPENINGS FOR SUBSURFACE UTILITIES

19.010.01. APPLICABILITY.

The following specifications shall apply to excavators, which term includes any person, contractor, partnership, corporation, municipality, special district, or other governmental entity, who for any reason cuts, disturbs or otherwise defaces any county property being a public right-of-way for purposes of installing or repairing or for any reason pertaining to the presence of an underground utility or structure. Once an excavator obtains an excavation permit he or she shall be considered a permittee.

19.010.02. PLANS TO BE SUBMITTED BEFORE WORK BEGINS.

Plans and profiles for any work affecting grade and alignment shall be required to be submitted to the Huerfano County Road and Bridge Department for approval before starting any such work.

19.010.03. HOLD HARMLESS AGREEMENT.

The excavator acquiring a permit for the purpose of performing work on any county property, being a thoroughfare or right-of-way, is assumed to be familiar with and at all times shall observe and comply with all federal and state laws, local by-laws, ordinances and regulations in any manner affecting the conduct of his or her work. He or she shall indemnify and hold harmless the County of Huerfano, Colorado, and its representatives against any claims arising from any violation of such law, by-law, ordinance or regulation; whether by the excavator himself or herself or by the excavator's employees. The County of Huerfano reserves the right to refuse issuance of permits to any excavator not complying with the above-outlined procedures or with the following specifications.

19.010.04. BONDING, INSURANCE AND WARRANTY REQUIREMENTS.

A. Before the county shall issue a permit to any excavator, that excavator shall have on file with the Huerfano County Regional Building Authority a valid contractor's license and permit bond in the amount of two thousand five hundred dollars (\$2,500.00). Such bond shall be for the benefit of the Huerfano County Road and Bridge Department, and shall assure recovery by the Department of any expense incurred by the Department in completing work begun, but not finished, by the excavator in accordance with these regulations and specifications. Such bond shall be in force for at least sixty (60) days beyond the anticipated completion date of any work for which a permit is being applied for.

Huerfano County
Land Use Department
401 Main Street, Suite 304
Walsenburg, CO 81089
719-738-1220 x506

**HUERFANO COUNTY
ROADWAY DESIGN AND
CONSTRUCTION
STANDARDS
SECTION 19.00**



B. Before the county shall issue a permit to any excavator, that excavator shall show evidence of a valid and in-force bodily injury and property damage liability insurance policy, with minimum limits of five hundred thousand dollars (\$500,000.00) combined single limit coverage. Such policy shall be for the protection of the county from all suits, actions or claims of any type for injuries or damages allegedly sustained by any person or property on the premises or as a result of the operations or completed operations of the work. Such policy shall specifically cover the acts and operations of any subcontractors or independent contractors of the excavator, in addition to the excavator's employees or agents.

C. In addition to the bonding and insurance requirements of subsections A and B of this section, the permittee personally, by applying for and obtaining a permit, agrees to be liable to Huerfano County for any expenses incurred by Huerfano County because of the permittee's acts or omissions relating to the work, and the permittee shall hold Huerfano County harmless from any claims of anyone else arising from or relating to the work. This shall include, but not be limited to, a warranty by the permittee of the work and all materials and labor used in the work, and such warranty shall run for one year from the completion of the work and shall guarantee that no further repairs or maintenance will be required at the work site due to any defect or omission in the work or that the permittee will adequately and properly provide and complete any such repairs or maintenance. For any work on a job with roadway repair costs in excess of two thousand five hundred dollars (\$2,500.00) as estimated by Huerfano County, the warranty requirement shall be satisfied by the posting of a surety bond in the estimated amount at the discretion of Huerfano County.

D. The Huerfano County Board of County Commissioners may, at its discretion, exempt an excavator from the bonding requirements of subsection A of this section and from the insurance requirements set out in subsection B of this section. Such exemption may be granted upon a showing by the excavator of alternative arrangements satisfactory to the Huerfano County Board of County Commissioners. In determining whether to so exempt a particular excavator, the Huerfano County Board of County Commissioners shall consider the reliability of any alternative bonding or insurance devices proposed by the excavator, the financial condition and solvency of the excavator, the presence in Huerfano County of fixed assets sufficient in value to cover any expenses or problems caused by the excavation, the length of time the excavator has done business in Huerfano County, the previous track record of the excavator in regard to expenses or problems of prior excavations, the existence of a long-term or comprehensive policy of self-insurance by the excavator, and any other factors tending to increase or decrease the likelihood of expense and harm to Huerfano County from the excavation. **(Res. 06-24 As Amended)**

19.010.05. PERMITS.

**HUERFANO COUNTY
ROADWAY DESIGN AND
CONSTRUCTION
STANDARDS
SECTION 19.00**



- A. Prior to commencing any work on any county right-of-way, the excavator who will actually perform the work or their duly authorized representative shall obtain written permission to undertake such work in accordance with the following provisions.
- B. Permits issued by the Huerfano County Road and Bridge Department shall pertain only to allowing work within the county rights-of-way and is in no way a permit to enter onto private property adjacent to such rights-of-way nor to alter or disturb any facilities or installations existing within the right-of-way which may have been installed and are owned by others.
- C. Minimum fees shall be assessed for permits at the time of issuance of the permit. Inspection fees will be assessed to the permittee on the basis of actual inspection time required on a job site, at the current hourly rate for inspection time. The amount of the fees shall be established to cover the actual cost to Huerfano County incurred in the administration and enforcement of these regulations as approved by the Huerfano County Board of County Commissioners. The fees shall in no way be construed to constitute the prior assessment of damages by the Huerfano County Road and Bridge Department. The Board of County Commissioners may, at their discretion, wave the required fees in the interest of public safety, welfare and health.
- D. Permits issued shall be available for inspection at the project site at all times. The permit shall be shown to any representative of Huerfano County upon request.
- E. Permits shall be required for emergency repairs; however, a delay of seventy-two (72) hours is granted in securing the permit. Failure to acquire a permit within this specified time shall result in a penalty permit being issued.
- F. The work of adjusting manhole rings and service boxes at the request of Huerfano County shall be exempt from requiring a permit.
- G. Any excavator commencing work prior to obtaining a right-of-way cutting permit, except as provided herein, shall be required to obtain a penalty permit in lieu of the normal permit; and shall pay the additional fee pertaining thereto.
- H. A traffic control plan must be submitted to the Huerfano County Road and Bridge Department prior to the issuance of an excavation permit. The traffic control plan must comply with the standards set forth in the Manual of Uniform Traffic Control Devices (MUTCD). The traffic control plan must be signed by an individual whose signature shall constitute certification that the plan meets or exceeds MUTCD standards. Included with this plan shall be a detailed drawing of the project location showing all phases of the project, a list of the posted speed limits throughout the project, and a detailed drawing of the traffic control measures to be employed on the

**HUERFANO COUNTY
ROADWAY DESIGN AND
CONSTRUCTION
STANDARDS
SECTION 19.00**



project site.

I. In an emergency situation, signing according to the MUTCD shall be required on the project site even though a permit will not be issued until after the excavation has taken place. (Res. 06-24 As Amended)

19.010.06. PUBLIC CONVENIENCE AND SAFETY.

A. If an opening shall cross a roadway, only one-half of the roadway shall be closed at one time.

B. However, should the work being done necessitate closing the entire roadway a written request must be submitted to the Huerfano County Road and Bridge Department at the time of obtaining the permit. The request may be granted at the discretion of the Huerfano County Road and Bridge Department, in writing, after the applicant has provided the county with the written request. The county will notify the Huerfano County Sheriff's Department, the Colorado State Highway Patrol Division, the ambulance services and the fire protection districts of the closing specifying the exact location, date and time the roadway will be closed.

C. Should an emergency arise which will necessitate closing a roadway, written permission shall be waived. However, the permittee must notify all of the agencies listed in subsection A of this section and the Huerfano County Road and Bridge Department immediately.

D. The permittee shall, at his or her expense, take all necessary precautions for the protection of his or her work and the safety of the public. Where normal traffic flow is to be interrupted, the excavator shall provide, erect and maintain all necessary barricades, standard caution signs, warning signs, directional signs, flares and lights. The control devices and their placement shall comply with the current edition of the Manual on Uniform Traffic Control Devices, (MUTCD), and any supplements thereto, including but not limited to the Colorado Supplement. (Res. 06-24 As Amended)

19.010.07. RIGHT-OF-WAY OPENINGS.

A. Any work done under this permit shall result in repairs being made to the road or other county property involved, such repairs causing the road or property to be returned to a condition equal to the original, within the limits of careful, diligent workmanship, good planning and quality materials. These repairs must be accomplished in the least possible time and with the least disturbance to the normal function of the road or other property. All shallow cuts shall be made with straight

**HUERFANO COUNTY
ROADWAY DESIGN AND
CONSTRUCTION
STANDARDS
SECTION 19.00**



boundaries and all cuts shall be within five degrees of vertical l. In cases where caving or slump of a cut face occurs from under any roadway surfacing, slab or bound type base, the dimensions of the cut shall be extended to the point of occurrence of caving or slump.

B. All work in connection with blasting operations, including necessary and proper safety precautions, shall be performed under the inspection of the Huerfano County Road and Bridge Department. The excavator shall comply with all laws, ordinances, regulations and requirements of applicable safety codes relative to the handling, storage and use of explosives and the protection of life and property, and he or she shall be responsible for all damages thereto caused by his or her blasting operations. Suitable weighted plank coverings or mattresses shall be provided to confine all materials lifted by blasting within the limits of the excavation or trench.

C. Except where trench banks are cut back on a stable slope to prevent caving or sliding, trenches shall be properly and substantially braced, and sheeted where necessary, to prevent caving or sliding. Sheeting shall be supported by means approved by the Occupational Safety and Health Administration (OSHA). Cross braces installed for the purpose of supporting sheeting in the bottom of the trench shall be removed after the specified tamped embedment has been completed beyond the point of cross brace removal.

E. No openings shall be permitted on any asphalt roads in Huerfano County rights-of-way that are under three years old. This shall also include roads which have been resurfaced or plant mixed sealed which are under three years old. This provision may be waived at the discretion of the Huerfano County Board of County Commissioners if the contractor shall meet with representatives of Huerfano County and thoroughly review his or her plans for the proposed job. A list of roads to which this provision applies is available at the Huerfano County Road and Bridge Department. This provision, however, shall not prohibit any emergency utility work which must be performed. Huerfano County will make every effort to inform utility companies of scheduled construction or overlays at least six months in advance of such work. (. Res. 06-24 As Amended).

19.010.08. BACKFILL.

A. All backfill materials, compaction and resurfacing of any excavation made in the county property will be done in accordance with the provisions as follows: backfilling and compacting shall begin after first having properly bedded and compacted to a depth of not more than one foot over the top of the structure or utility line being installed or repaired in accordance with the specifications of the person or corporation responsible for the maintenance of the structure or utility line.

**HUERFANO COUNTY
ROADWAY DESIGN AND
CONSTRUCTION
STANDARDS
SECTION 19.00**



B. Materials acceptable for backfill purposes are divided into two categories as follows:

1. Native backfill: that material which was originally removed from excavation, after having had all organic material, frozen material, material larger than that which will pass through a three-inch square opening, or other elements other than natural soils removed and discarded. This type will be acceptable to the Huerfano County Road and Bridge Department.
2. Select backfill: that granular material meeting the requirements as stated under the Bed Course Material Item Class 1 backfill or Class 2 backfill, of the Standard Specifications for Road and Bridge Construction, Department of Highways, State of Colorado (Current Issue) or materials falling within the AASHTO Classifications A-1-a or A-1-b under Specification M-145 except that materials of predominately one grain size, such as chips, pea gravel or single-sized waste from screening plants that are within these classifications may not be used, and materials in these classifications which do not pass through a three- inch square opening shall be omitted. The excavator may, at his or her option, remove any native backfill and substitute therefore select backfill materials. (Res. 06-24 As Amended)

19.010.09. COMPACTION.

Compacting of backfill must progress by placing of backfill in eight-inch lifts thoroughly compacted and wetted if necessary to achieve densities according to the following:

- A. Materials of AASHTO Classifications A-1-a or A-3 shall be consolidated by jetting, puddling, rolling or vibrating at the discretion of Huerfano County.
- B. Materials of AASHTO Classification A-1-b shall be compacted to ninety-five (95) percent of modified Proctor Density.
- C. Materials of AASHTO Classification A-2 and A-4 through A-7 shall be compacted to ninety- five (95) percent of Standard Proctor Density. (Res. 06-24 As Amended)

19.010.010. COMPACTION TESTS.

- A. Compaction tests shall be taken on longitudinal or crosscuts at the request of the Huerfano County Road and Bridge Department. These tests shall be taken

**HUERFANO COUNTY
ROADWAY DESIGN AND
CONSTRUCTION
STANDARDS
SECTION 19.00**



at the depth and location specified by the county and shall meet the requirements specified in Section 10.09.

B. The excavator shall have the compaction tests conducted by an approved testing laboratory. A copy of the results shall be furnished to the Huerfano County Road and Bridge Department no later than five days after the test is conducted. (Res. 06-24 As Amended)

C. Compaction tests do not relieve the contractor of his or her obligation to maintain said repairs as guaranteed under Section 10.04(C). (Res. 06-24 As Amended)

19.010.011. RESURFACING.

A. After proper backfill procedures are completed in accordance with the preceding requirements, the vacant depth shall be surfaced to a condition equal to or better than the existing surface. Temporary and/or permanent repairs shall begin within twenty-four (24) hours after backfilling is completed on roads or highways designated by the Road and Bridge Department and continue until all repairs are made. (See subsection F of this section.) On all other roads or highways permanent repairs shall be completed within a period of fifteen (15) calendar days. At the discretion of the Huerfano County Road and Bridge Department, a delay of up to seven days in the time designated for initiation or completion of repairs may be granted. The twenty-four (24) hour designation will be noted on the permit at the time of issuance. The following minimum standards shall apply to all resurfacing done in the county.

B. Gravel Surfaced Roads. Backfill shall be placed to within twelve (12) inches of the surface, and the twelve (12) inch vacant depth shall be filled with thoroughly tamped granular material meeting the requirements specified under the aggregate for Bases Item, Class 6 of the Standard Specifications for Road and Bridge Construction, Department of Highways, State of Colorado (current issue), or materials extracted at the same precise location, or other suitable granular materials approved by the County Administrator with the approval of the Board of County Commissioners. After a disturbance in the surface of the road, the road must be restored to have 4"-6" inches of gravel across the whole width of the road and to be inspected by Road and Bridge Department.

Repair to roads in poor condition or roads lacking road base at the time of disturbance is to be negotiated with Road and Bridge prior to any disturbance. See 10.11.1.

C. Soil Cement Surfaced Roads. Backfill shall be placed within eighteen (18) inches of the surface, and granular material meeting the requirements specified under the Aggregate for Bases Item, Class 6 of the Standard Specifications for Road and Bridge Construction, Department of Highways, State of Colorado (current issue) shall be placed and thoroughly compacted to within eight inches of the surface. The eight-inch vacant depth shall be filled with five and one-half sacks

**HUERFANO COUNTY
ROADWAY DESIGN AND
CONSTRUCTION
STANDARDS
SECTION 19.00**



per cubic yard Portland cement concrete, which shall be struck and floated to match adjacent undisturbed surface. Ninety-five (95) percent of patched surface shall match the plane of the adjacent surface, when measured by means of six-foot straight edge or beam, within one-eighth inch.

D. Portland Cement Surfaced Roads. Backfill shall be placed within eighteen (18) inches of the surface or ten (10) inches below the bottom of the existing slab, whichever is the deepest, and the next ten (10) inches shall be filled with thoroughly compacted granular material as described in subsection C of this section. The eight-inch minimum vacant depth shall be filled with six and one-half sacks per cubic yard Portland cement concrete which shall be struck and floated to match the adjacent undisturbed surface. Ninety-five (95) percent of this patched surface shall match the plane of the adjacent undisturbed surface, when measured by means of a six-foot straight edge or beam, within one-eighth inch.

E. Asphaltic Concrete Surfaced Roads. Backfill material shall be placed within twelve (12) inches of the surface. Granular material described in subsection C of this section shall be placed and thoroughly wetted and compacted to within four inches of the surface. Prior to placing of Asphaltic concrete, the edges of the cut shall be coated with a tack oil of CSS-1 at not less than 0.10 gallons per square yard. The four-inch vacant depth shall be filled with asphaltic concrete in two-inch lifts and thoroughly compacted. Asphaltic Concrete for this purpose shall be mixed with asphaltic cement of the AC-10 type or equal. Ninety-five (95) percent of this patched surface shall match the plane of the adjacent undisturbed surface, when measured by means of a six-foot straight edge or beam, within one-eighth inch.

A prime coat of MC-70 oil applied at a rate of 0.30 gallons per square yard may be required on the surface area of granular material at the time of the issuance of a permit or as directed by the Huerfano County Administrator and/or Planner.

1. Required Overlay: Overlay of the entire road width and ten (10) feet beyond each end of damaged area may be required, at the discretion of the Road and Bridge Department, when utility installation is made longitudinally within five feet of, or on the centerline of the paved road for a length of seventy-five (75) linear feet or more. For lengths less than the above- stated, the repairs and/or overlays must be made as agreed to by the excavator and the County Inspector, prior to obtaining a permit. If the excavation within five feet of the centerline does not extend into the adjacent traffic lane, overlay of only one-half of the entire road width may be required.

Overlay of one-half of the entire road width and ten (10) feet beyond each end of damaged area shall be required when utility installation is made longitudinally within the area five feet from centerline and edge of paved road for a length of seventy-five (75) linear feet or more. Again for lengths less than the above-stated,

**HUERFANO COUNTY
ROADWAY DESIGN AND
CONSTRUCTION
STANDARDS
SECTION 19.00**



the repairs and/or overlays must be made as shall be agreed to by the excavator and the County Inspector, prior to obtaining a permit.

Overlay of the entire road width and ten (10) feet beyond each end of incorporated damaged area shall be required when two or more lateral utility installations are made by the same utility excavator within seventy-five (75) linear feet of road length. Three or more lateral utility installations within one hundred fifty (150) linear feet of road length and or more lateral utility installations within three hundred (300) linear feet of road length will also require full road width of overlay.

The minimum compacted depth of the Asphaltic Concrete overlay shall be five-eighths inch with edges feathered as much as possible eliminating the fracturing of the mix aggregate. The areas of overlay shall require a tack coat of CSS-1 at the rate of 0.10 gallons per square yard.

2. The overlay described in subsection (E)(1) of this section must be placed by a mechanized self-propelled paver and finished in a good workmanlike manner and using good commercial practices.

F. During certain times of the year when hot plant-mixed asphalt is unavailable, cold plant-mixed asphaltic concrete may be placed using above-stated procedures, however, this shall not be considered a permanent patch, and the excavator shall maintain this temporary patch as required to insure proper and safe movement of traffic until such time as a permanent patch is installed. The responsible excavator shall install a permanent patch with hot Asphaltic Concrete within fifteen (15) days following the availability of the proper material.

G. At the conclusion of work on any road, cut or opening within the Huerfano County right-of- way, the entire area shall be left in its original condition. All waste construction or excavated materials shall be removed from the site and disposed of within seventy-two (72) hours. Any ditches, gutters, culverts or drain pipes shall be left unblocked and in a condition as good as or better than the original condition. (Res. 06-24 As Amended)

19.010.012. Inspections.

A. The Huerfano County Road and Bridge Department Inspector shall be notified twenty-four (24) hours in advance of making any type of cut or doing any excavation in County right-of- way except as stated in Section 10.13(B). Failure by

**HUERFANO COUNTY
ROADWAY DESIGN AND
CONSTRUCTION
STANDARDS
SECTION 19.00**



the excavator to notify the Inspector as stated above may result in revocation of the original permit and issuance of a penalty permit as per Section 10.15(0).

B. Inspections will be made as deemed necessary during the construction period by the County to

C. insure that work is processing in compliance with the regulations stated herein. Deviation from these regulations and requirements will be sufficient reason for shut down orders to be issued by the County until proper corrections or adjustments have been made by the excavator.

D. Before a pavement section is replaced (patched), the excavator shall notify the County Inspector as to the date such work is proposed. Failure of notification may result in a demand to have such work redone in order to pass a final inspection.

E. Upon satisfactory completion of work, including the replacement of paved sections and gravel road repairs, a final inspection shall be made. Upon the County's final inspection, the completed permit is then retained by the County, and the permittee is held liable for his or her work as stated in Section 10.04(C). (Res. 06-24 As Amended)

19.010.013. EMERGENCY WORK.

A. Nothing in this chapter shall be interpreted to prevent the excavator from performing emergency work prior to obtaining a permit.

B. Huerfano County Road and Bridge Department shall be notified immediately after an emergency utility cut is made. In all other cases, a twenty-four (24) hour advance notification shall be required. (Res. 06-24 As Amended)

19.010.014. NOTICE TO EXCAVATORS.

A. Failure on the part of the permittee to properly complete the work of resurfacing, which will necessitate the performance of work by the Huerfano County Road and Bridge Department forces, shall be charged to the permittee.

First Square yard, two hundred forty dollars (\$240.00) minimum charge.

All additional square yards at eight-six dollars (\$86.00) per square yard.

B. Costs of placing barricades, providing signing according to MUTCD standards pursuant to Section 10.0S(H), and/or interim repairs required due to the failure of the

**HUERFANO COUNTY
ROADWAY DESIGN AND
CONSTRUCTION
STANDARDS
SECTION 19.00**



excavator to maintain safe conditions will be billed to the permittee. (Res. 06-24 As Amended)

19.010.015. PERMIT FEE SCHEDULE.

A. The minimum permit fee for each roadway opening will be one hundred fifty dollars (\$150.00). This fee will cover all administrative costs associated with the issuance of the permit, the initial inspection of the site including traffic control inspection, and the warranty inspection. In addition to this minimum permit fee, the permittee will be billed for costs incurred by Huerfano County for additional inspection time involving the Huerfano County Inspector. If the initial inspection fails, the fee for additional inspection will be fifty dollars (\$50.00). Because this rate is based on actual costs to the county, it will be adjusted by resolution as necessary by the Board of County Commissioners.

B. The following is a schedule of estimated inspection time and cost which a permittee may expect to be assessed in reference to the type of work being permitted. This cost is in addition to the minimum fee discussed in subsection A of this section.

1. Cross Roads Cuts/Bores:

The minimum fee for any cross road cut and/or bore will be one hundred and twenty dollars (\$120.00) per cut/bore plus a thirty dollar (\$30.00) permit fee. More than one cross road cut/bore within the same county road may be included within a single permit with an additional charge of twenty dollars (\$20.00) for each additional cut/bore. This in effect is a one hundred dollar (\$150.00) minimum charge.

2. Road Cuts:

The minimum fee for any road cut not exceeding the width of the road will be seventy dollars (\$70.00) per cut plus a thirty dollar (\$30.00) permit fee. More than one road cut within the same county road may be included within a single permit with an additional charge of twenty dollars (\$20.00) for each additional cut. This in effect is a one hundred dollar (\$100.00) minimum charge.

3. Longitudinal Cuts

Longitudinal cuts will be charged according to the following fee schedule:

0 to 300 feet-seventy dollars (\$70.00) in addition to a thirty dollar (\$30.00) permit

**HUERFANO COUNTY
ROADWAY DESIGN AND
CONSTRUCTION
STANDARDS
SECTION 19.00**



fee. This in effect is a one hundred dollar (\$100.00) minimum charge.

301 feet and over - seventy dollars (\$70.00) plus thirty cents (.30) per linear foot for every foot over 300 feet.

4. Utility Poles and/or Aerial Cable Placement

A one hundred dollar (\$100.00) permit fee will be required for each road crossing. Each subsurface utility, utility pole and /or aerial cable placement shall be, additionally, approved by the Huerfano County Board of County Commissioners.

5. Penalty Permit

A penalty permit shall be issued to any contractor commencing work prior to obtaining a right-of- way cutting permit. The fee for this permit shall cover the foregoing plus a penalty of five hundred dollars (\$500.00).

C. Right-of-Way Excavation. An excavation which in no way interferes with traffic and is not made in any portion of the road including the shoulder.

1. The total fee for an excavation made in the county right-of-way in conjunction with a meter set, bore or push will be one hundred dollars (\$100.00), providing that the cut does not interfere with drainage improvements. Inspections which must be performed due to noncompliance with permit regulations will be charged to the permittee.

2. There will be no minimum fee required for a permit obtained for the purpose of repairing a meter, provided that the work will not interfere with any right-of-way improvements. The permittee will however, be charged for inspections made due to noncompliance with permit regulations. A permit and traffic control plan will be required to keep Huerfano County informed of work planned in its jurisdiction and to insure the protection and safety of the motoring public.

D. In addition to fees listed in the fee schedule, the permittee will be charged for any inspections made necessary due to noncompliance with regulations or the failure of any work.

E. Penalty Permit. This permit shall be issued to any excavator commencing work prior to obtaining a basic right-of-way cutting permit. Failure by the excavator to notify the County Inspector as stated in section 10.12(A) may result in revocation of the original permit and issuance of a penalty permit. The fee for this permit shall cover the foregoing plus a penalty of five hundred dollars (\$500.00). (Res. 06-24 As Amended).

Huerfano County
Land Use Department
401 Main Street, Suite 304
Walsenburg, CO 81089
719-738-1220 x506

**HUERFANO COUNTY
ROADWAY DESIGN AND
CONSTRUCTION
STANDARDS
SECTION 19.00**



19.011. DEFINITIONS

Wherever the following words, phrases or abbreviations appear in these STANDARDS they shall have the following meanings.

AASHTO - The American Association of State Highway and Transportation Officials. ASTM - The American Society for Testing Materials.

COOT -The Colorado Department of Transportation.

Construction Plans - Detailed working plans including plan and profile, details, notes and any other information necessary for complete construction of the required improvements.

Contractor - Shall mean a person, partnership or corporation performing work within the public right-of-way.

County - Huerfano County, Colorado.

Design Speed - A speed determined for design and correlation of physical features of a road that influence vehicle operation; the maximum safe speed maintainable on a specified section of road when conditions permit design features to govern. Design speed is generally higher than the posted speed limit in order to provide a factor of safety and consider other conditions or uses of the road which may affect vehicle operation.

Developer - Person, partnership or corporation legally responsible for the construction of roads within a subdivision or development.

Construction Inspector - Authorized representative of the County assigned to make inspections for assurance of compliance of construction with the approved plans and these STANDARDS.

May - A permissive condition. No requirement for design or application is intended.

New road and new road construction -- terms which may apply to any and all of the following:

- a) Road created by new subdivision process where no road previously existed.
- b) Road which previously existed physically on the ground but was not accepted for maintenance by Huerfano County, and where request is being made that the County accept the road for maintenance.
- c) Road where a platted or deeded right-of-way has previously existed but the road

Huerfano County
Land Use Department
401 Main Street, Suite 304
Walsenburg, CO 81089
719-738-1220 x506

**HUERFANO COUNTY
ROADWAY DESIGN AND
CONSTRUCTION
STANDARDS
SECTION 19.00**



was never physically constructed.

Road Impact Construction season- permissible time of year for construction in County roadways as established by the Huerfano County Board of County Commissioners.

Shall - A mandatory condition. Where certain requirements in the design or application are described with the "shall" stipulation, it is mandatory that these requirements be met.

Should - An advisory condition. Where the word "should" is used, it is considered to be advisable with deviations allowed when evidence or reasons are provided that the intent of the design standards is met.

Sub-base - The layer or layers of specified or selected material of designed thickness placed on the sub-grade to support a base course.

Sub-grade - The top surface of a roadbed upon which the pavement structure and shoulders including curb and gutter are constructed.

Superelevation -- The raised portion of a roadway above the normal cross slope to prevent a vehicle from sliding outward from centrifugal force.

APPENDIX 1

Standard Details

LIST OF FIGURES

Figure 1.....	Principal Arterial, X-Section
Figure 2.....	Minor Arterial, X-Section
Figure 3.....	Major Collector, X-Section
Figure 4.....	Minor Collector, X-Section
Figure 5.....	Local Industrial, X-Section
Figure 6.....	Local Commercial, X-Section
Figure 7.....	Local Access, X-Section
Figure 8.....	Local Minor Residential, X-Section
Figure 9.....	Local Minor Residential – Gravel, X-Section
Figure 10.....	Cul-de-Sac Detail
Figure 11.....	Vertical Curves
Figure 12A.....	Mailbox Supports
Figure 12B.....	Mailbox Supports
Figure 13.....	Mailbox Supports
Figure 14.....	Mailbox Turnouts – Road ADT = 2000
Figure 15.....	Layered Pavement Design
Figure 16.....	Design Nomograph – Flexible Pavements
Figure 17.....	Soil Support Values
Figure 18.....	Design Nomograph for Gravel Roads – Serviceability Criteria
Figure 19.....	Design Nomograph for Gravel Roads – Rutting Criteria
Figure 20.....	Equivalent Thickness – Subbase vs. Base
Figure 21.....	Urban Driveways
Figure 22.....	Rural Driveways
Figure 23.....	Rural Driveways Profiles
Figure 24.....	Driveway Spacing
Figure 25.....	Culvert Headwalls – Pipes Smaller than 48 inch Diameters
Figure 26.....	Culvert Inlet/Outlet Paving
Figure 27.....	Alternate Ramp Curb & Gutter

TYPICAL X-SECTION

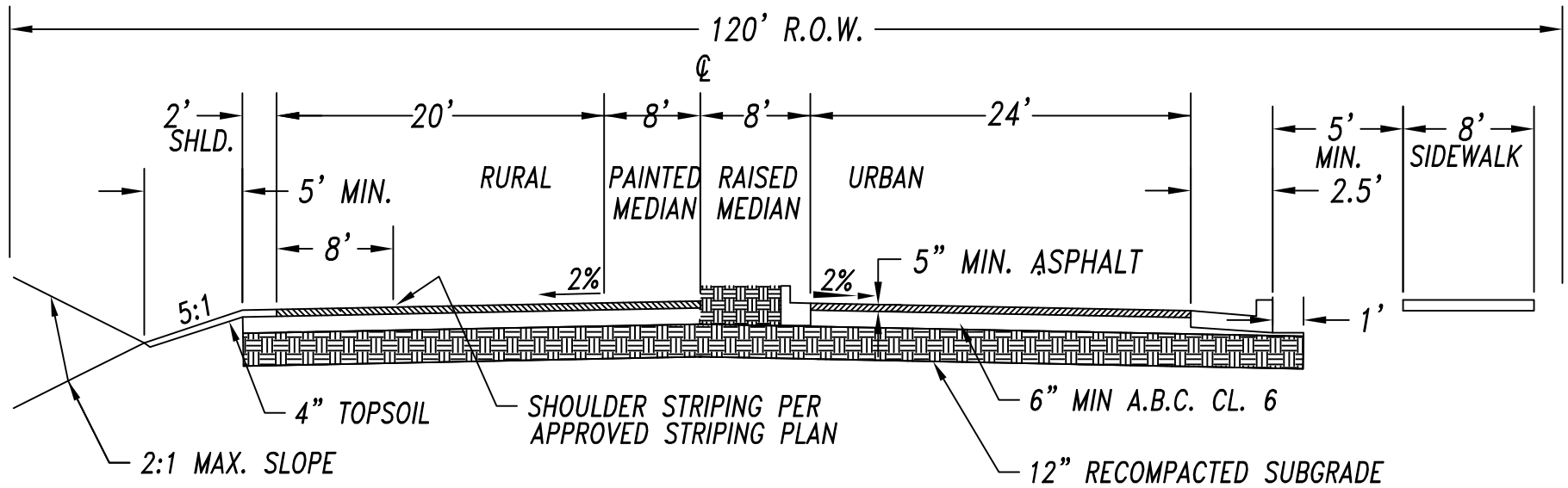

- NOTES:
1. Pavement design by a professional engineer is required - see Article No. 6.
 2. Full depth asphalt design allowed only with approval of Board of County Commissioners.
 3. Depth of A.B.C. class 6 to be supported by pavement design. Depth over 6" may be class 2 A.B.C. - minimum 4" depth.
 4. Additional right-of-way may be required where acceleration/deceleration lanes or turn lanes are required.

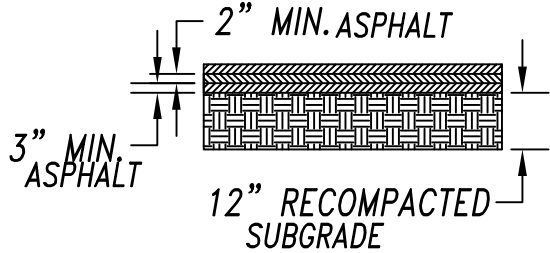

FULL DEPTH ASPHALT OPTION
MIN. TOTAL ASPHALT DEPTH - 7 INCHES

<h2>PRINCIPAL ARTERIAL</h2>		
HUERFANO COUNTY	APPROVED: _____ REVISED: _____ REVISED: _____	FIGURE NO. 1

TYPICAL X-SECTION

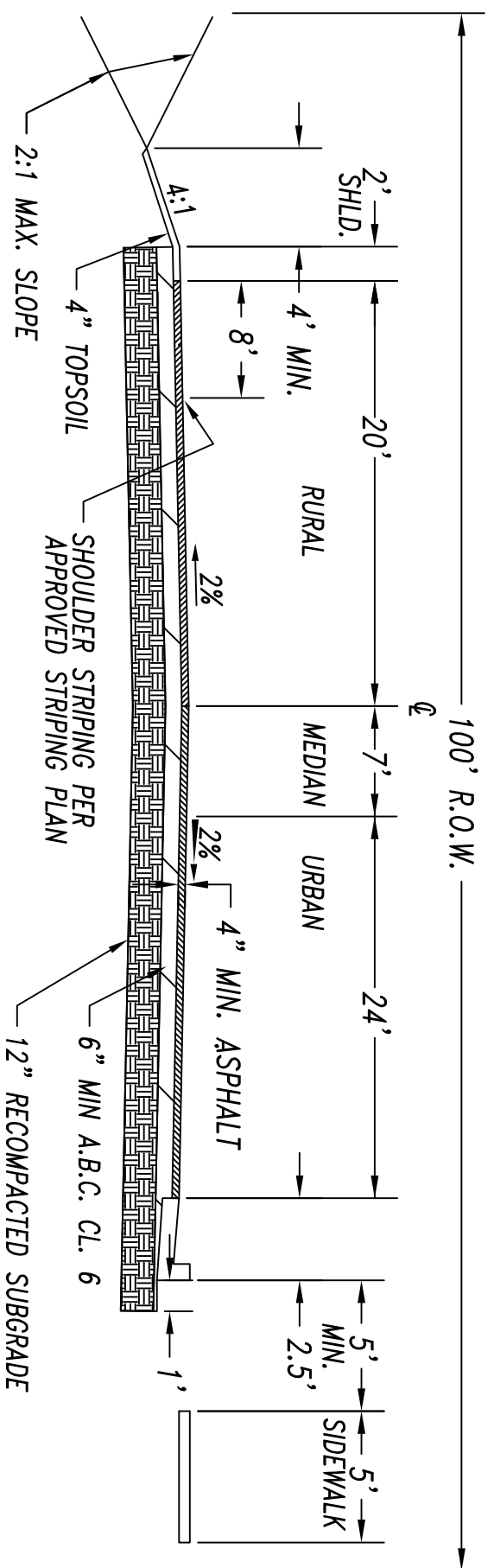

- NOTES:
1. Pavement design by a professional engineer is required – see Article No. 6.
 2. Full depth asphalt design allowed only with approval of Board of County Commissioners.
 3. Depth of A.B.C. class 6 to be supported by pavement design. Depth over 6" may be class 2 A.B.C. – minimum 4" depth.
 4. Additional right-of-way may be required where acceleration/deceleration lanes or turn lanes are required.

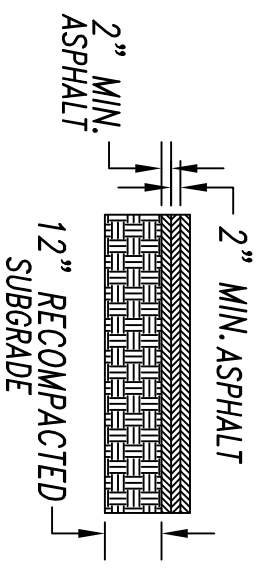

FULL DEPTH ASPHALT OPTION
MIN. TOTAL ASPHALT DEPTH – 6 INCHES

MINOR ARTERIAL

HUERFANO COUNTY

APPROVED: _____
REVISID: _____
REVISID: _____

FIGURE NO. 2

TYPICAL X-SECTION

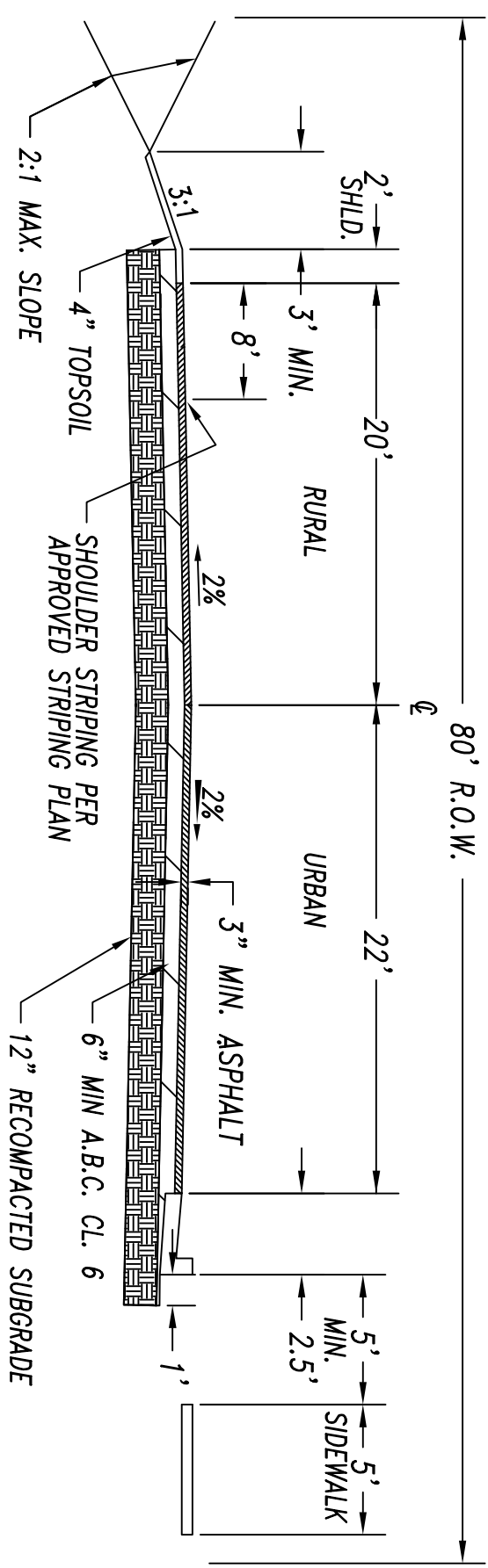

- NOTES:
1. Pavement design by a professional engineer is required – see Article No. 6.
 2. Full depth asphalt design allowed only with approval of Board of County Commissioners.
 3. Depth of A.B.C. class 6 to be supported by pavement design. Depth over 6" may be class 2 A.B.C. – minimum 4" depth.

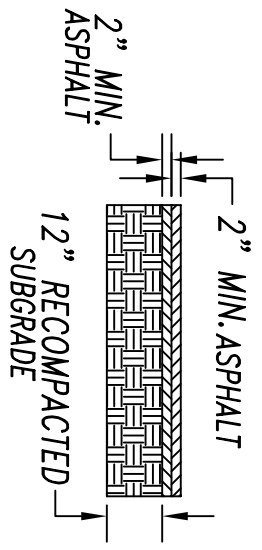

FULL DEPTH ASPHALT OPTION

MAJOR COLLECTOR	
HUERFANO COUNTY	APPROVED: _____ REVISED: _____ REVISED: _____
FIGURE NO. 3	

TYPICAL X-SECTION

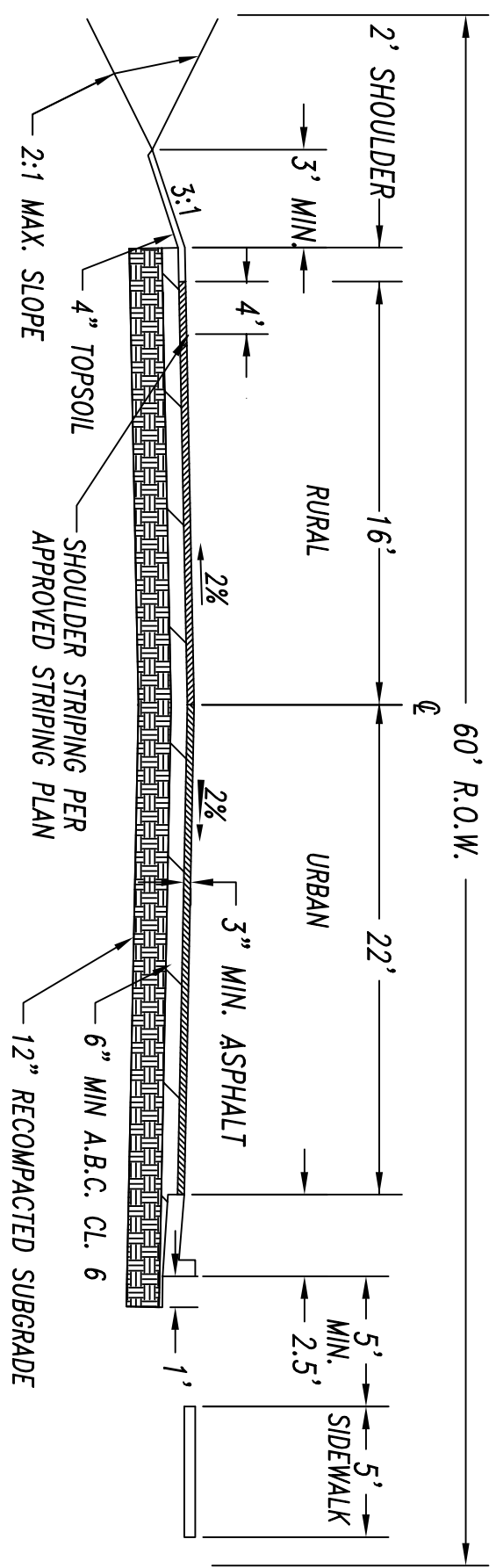

- NOTES:
1. Pavement design by a professional engineer is required – see Article No. 6.
 2. Full depth asphalt design allowed only with approval of Board of County Commissioners
 3. Depth of A.B.C. class 6 to be supported by pavement design. Depth over 6" may be class 2 A.B.C. – minimum 4" depth.

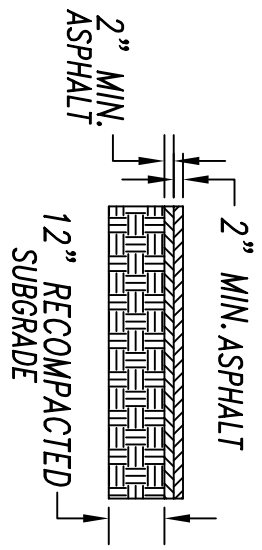

MINOR COLLECTOR

HUERFANO COUNTY

APPROVED: _____
 REVISED: _____
 REVISED: _____

FIGURE NO. 4

TYPICAL X-SECTION

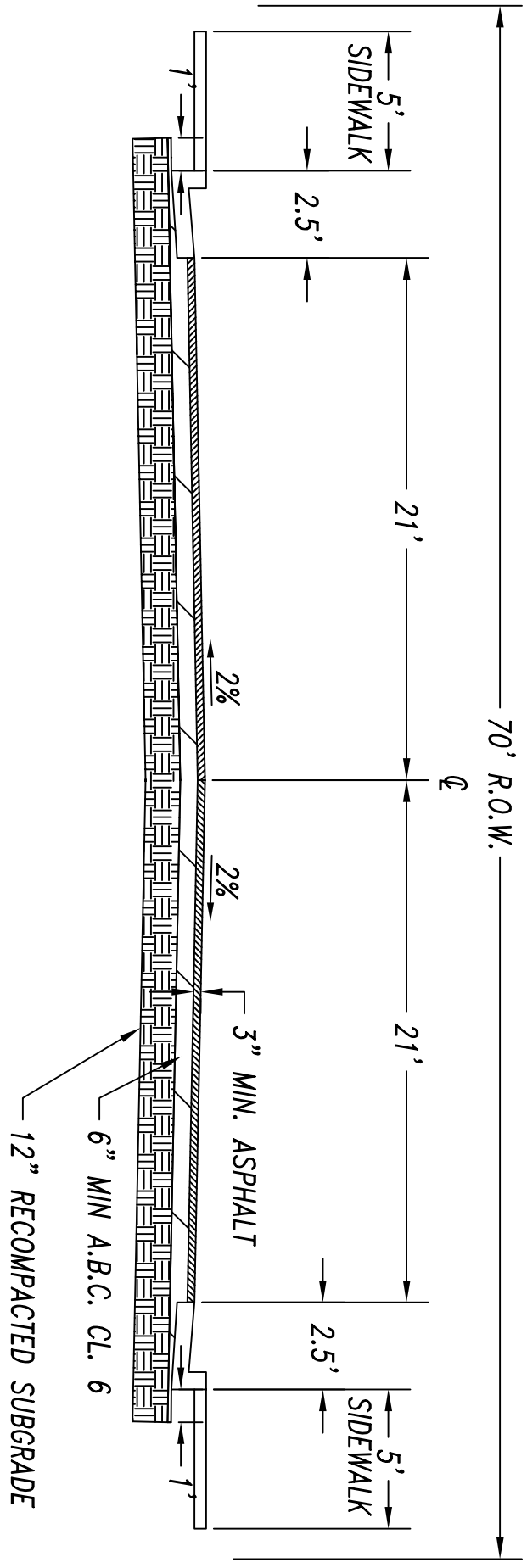

- NOTES:
1. Pavement design by a professional engineer is required – see Article No. 6.
 2. Full depth asphalt design allowed only with approval of Board of County Commissioners.
 3. Depth of A.B.C. class 6 to be supported by pavement design. Depth over 6" may be class 2 A.B.C. – minimum 4" depth.

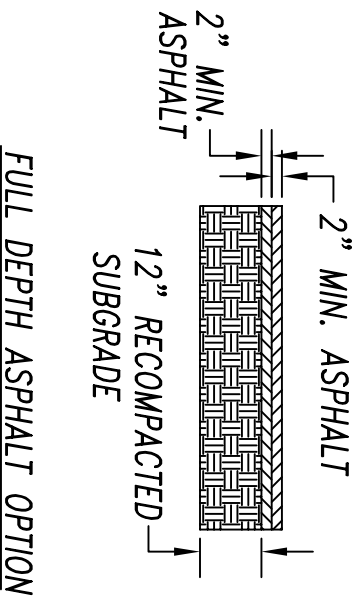

LOCAL INDUSTRIAL

HUERFANO COUNTY

APPROVED: _____
 REVISED: _____
 REVISED: _____

FIGURE NO. 5

TYPICAL X-SECTION

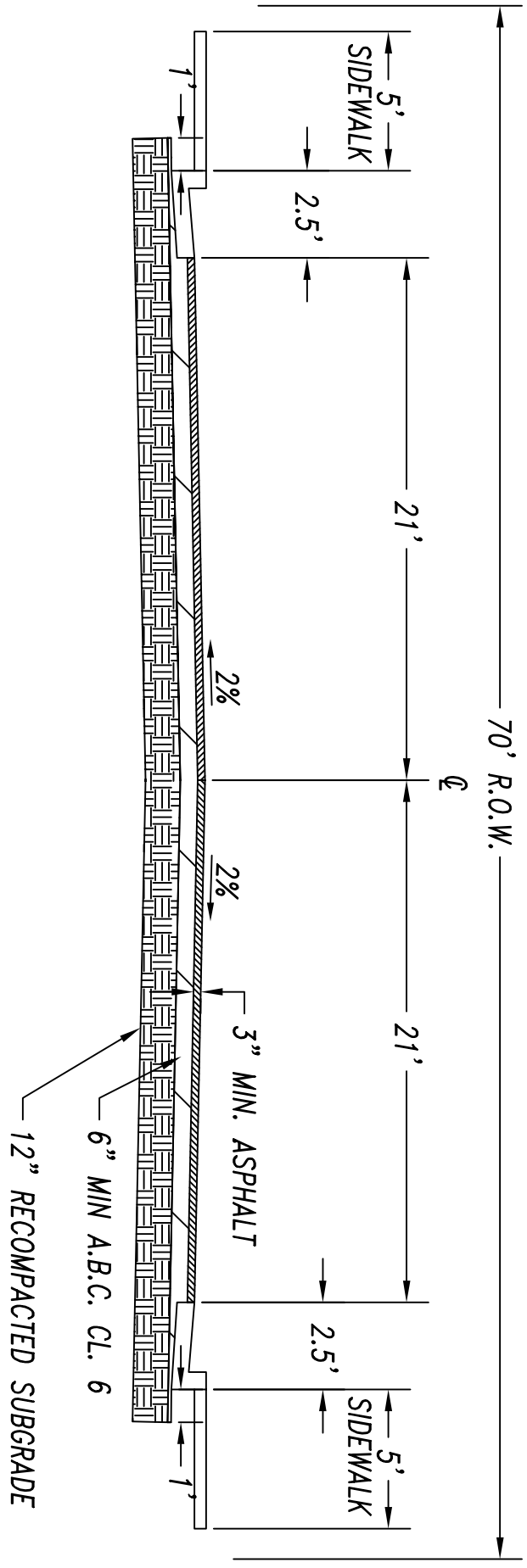

- NOTES:
1. Pavement design by a professional engineer is required – see Article No. 6.
 2. Full depth asphalt design allowed only with approval of Board of County Commissioners.
 3. Depth of A.B.C. class 6 to be supported by pavement design. Depth over 6" may be class 2 A.B.C. – minimum 4" depth.

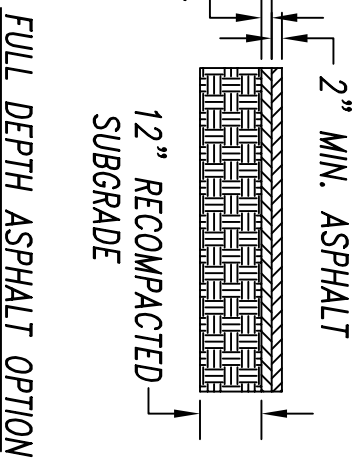

LOCAL COMMERCIAL

HUERFANO COUNTY

APPROVED: _____
 REVISED: _____
 REVISED: _____

FIGURE NO. 6

TYPICAL X-SECTION

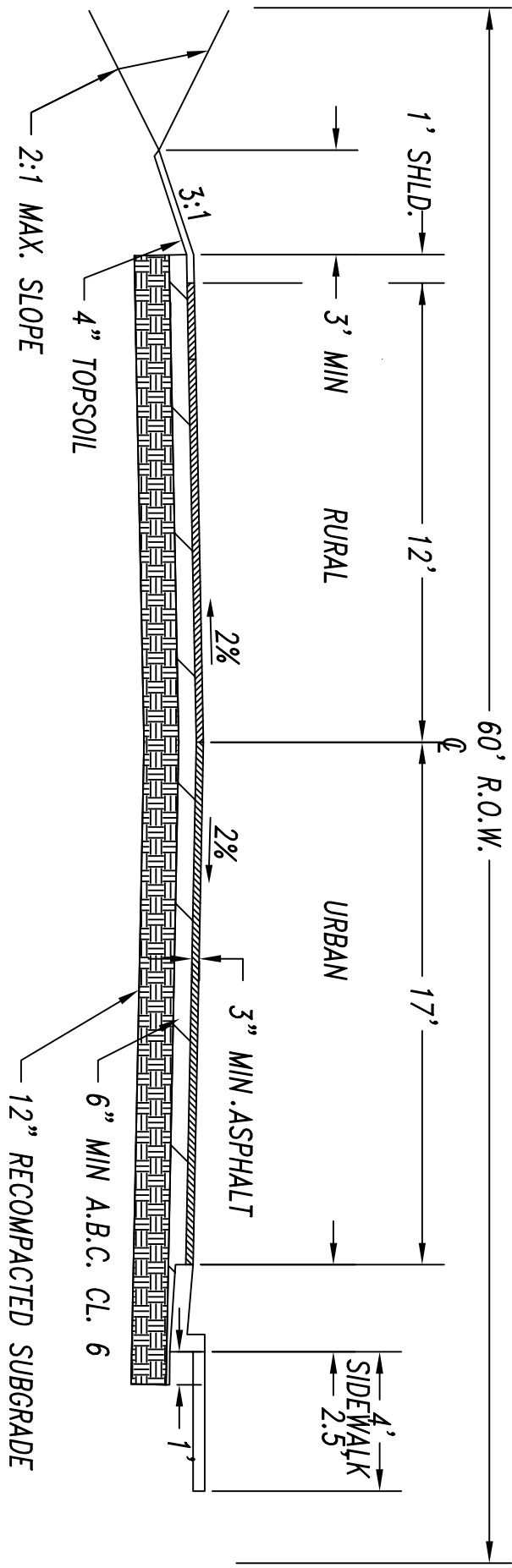

- NOTES: 1. Pavement design by a professional engineer is required – see Article No. 6.
2. Full depth asphalt design allowed only with approval of Board of County Commissioners.
 3. Narrower widths may be approved for urban section where adequate off street parking is provided and on street parking is prohibited.
 4. Depth of A.B.C. class 6 to be supported by pavement design. Depth over 6" may be class 2 A.B.C. – minimum 4" depth.
 5. Rural pavement width shown assumes no on street parking add minimum 4' total width where on street parking allowed.

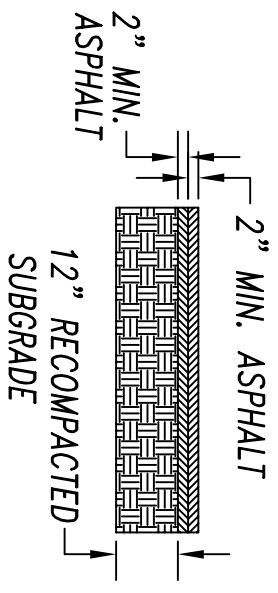

LOCAL ACCESS

HUERFANO COUNTY

APPROVED: _____
REVISID: _____
REVISID: _____

FIGURE NO. 7

TYPICAL X-SECTION 60' R.O.W.

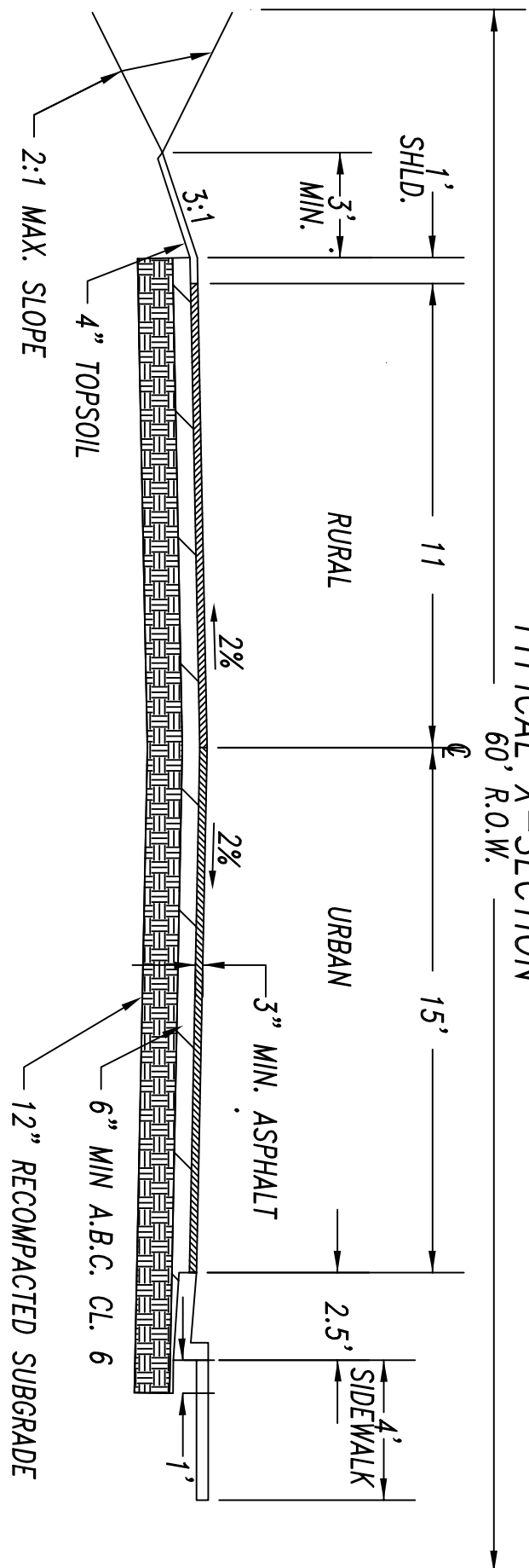

- NOTES: 1. Pavement design by a professional engineer is required – see Article No. 6.
2. Full depth asphalt design allowed only with approval of Board of County Commissioners.
 3. Narrower widths may be approved for urban section where adequate off street parking is provided and on street parking is prohibited.
 4. Depth of A.B.C. class 6 to be supported by pavement design. Depth over 6" may be class 2 A.B.C. – minimum 4" depth.
 5. Rural pavement width shown assumes no on street parking add minimum 4' total width where on street parking allowed.

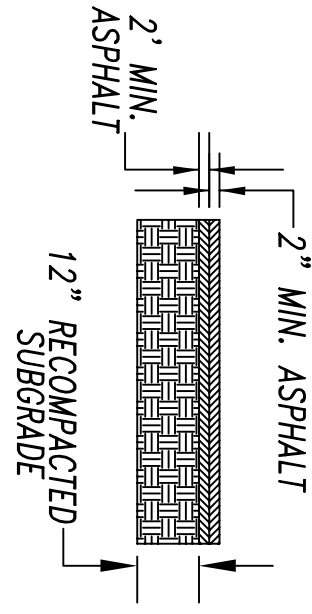

FULL DEPTH ASPHALT OPTION

LOCAL MINOR RESIDENTIAL

HUERFANO COUNTY

APPROVED: _____
 REVISED: _____
 REVISED: _____

FIGURE NO.
8

TYPICAL X-SECTION

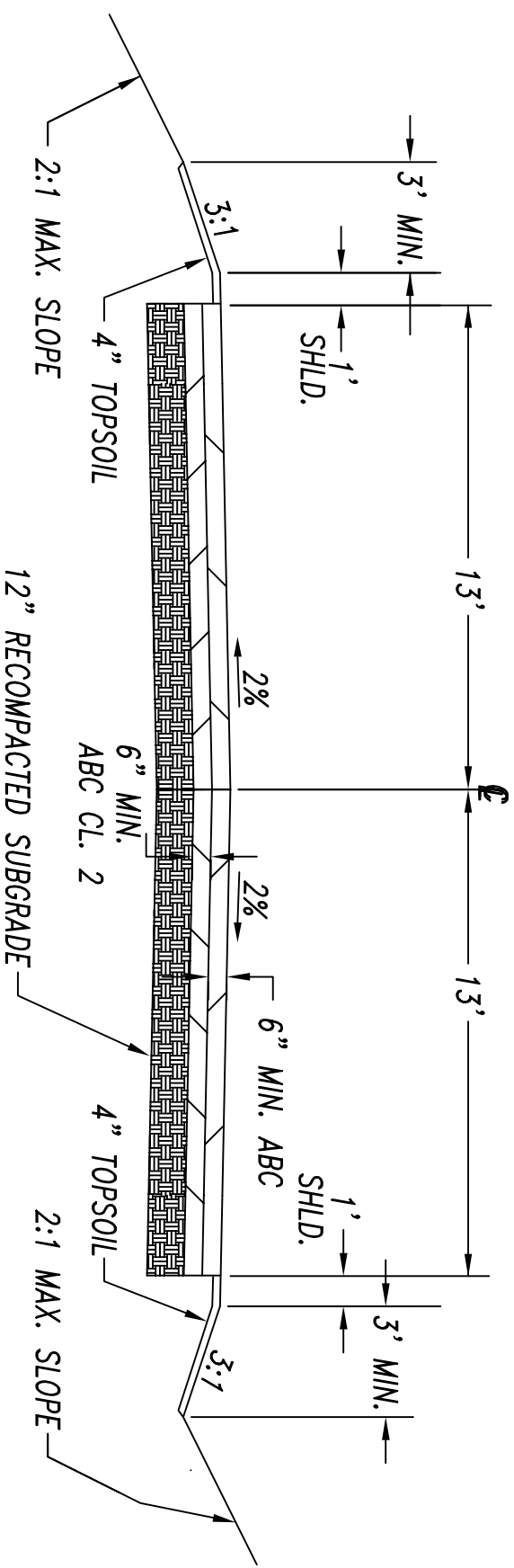

- NOTES:
1. Cross section design by professional engineer is required – see Article No. 6.
 2. Depth of class 6 A.B.C., class 2 A.B.C., to be supported by cross section design.
 3. Surface aggregate base course (A.B.C.) to be per Huertano County specifications – see Article No. 8.9

LOCAL MINOR RESIDENTIAL – GRAVEL	
HUERTANO COUNTY	APPROVED: _____ REVISED: _____ REVISED: _____
FIGURE NO. 9	

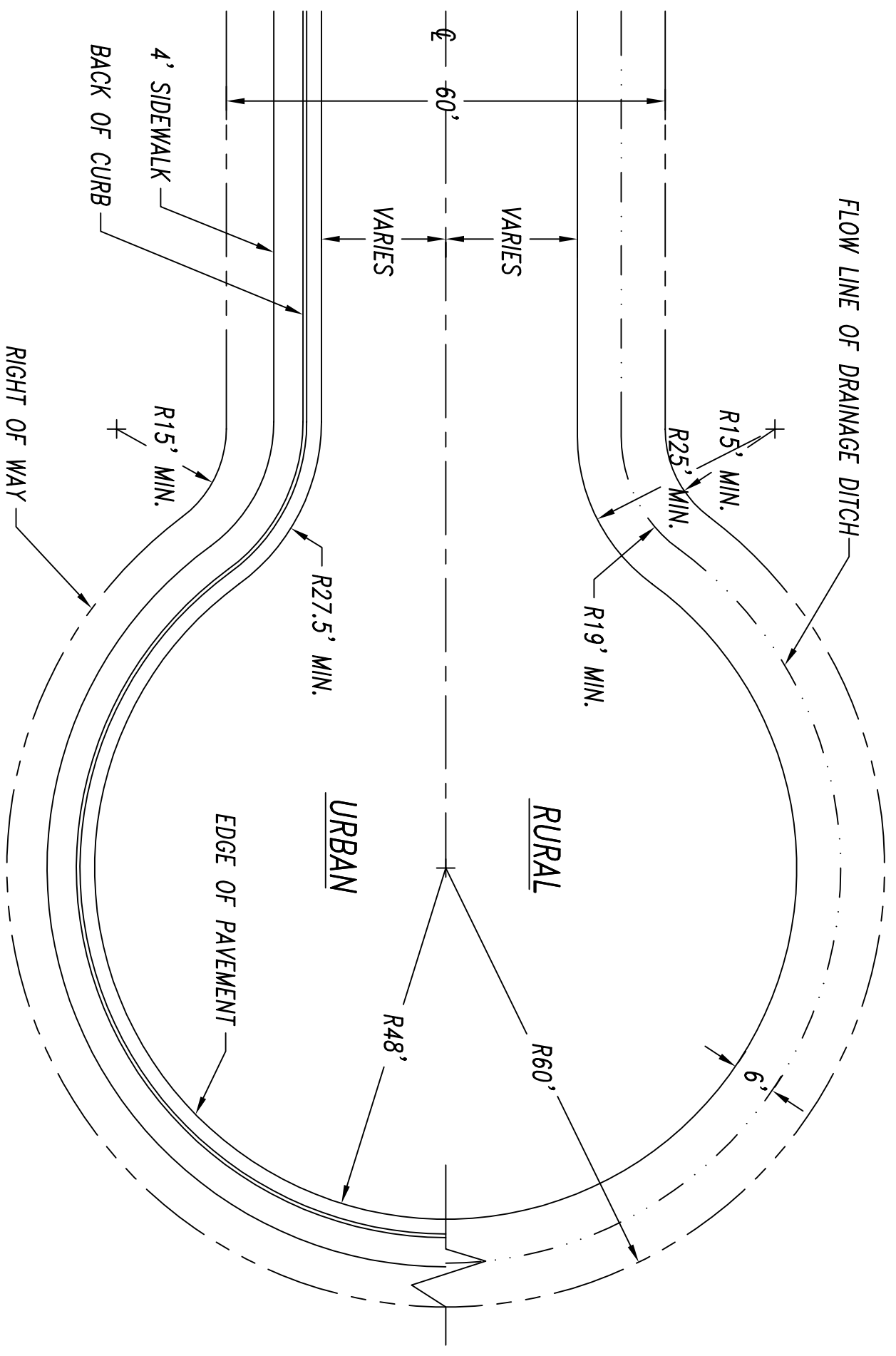

CUL-DE-SAC DETAIL

HUERFANO COUNTY

APPROVED: _____
 REVISED: _____
 REVISED: _____

FIGURE NO.
 10

TYPES OF VERTICAL CURVES

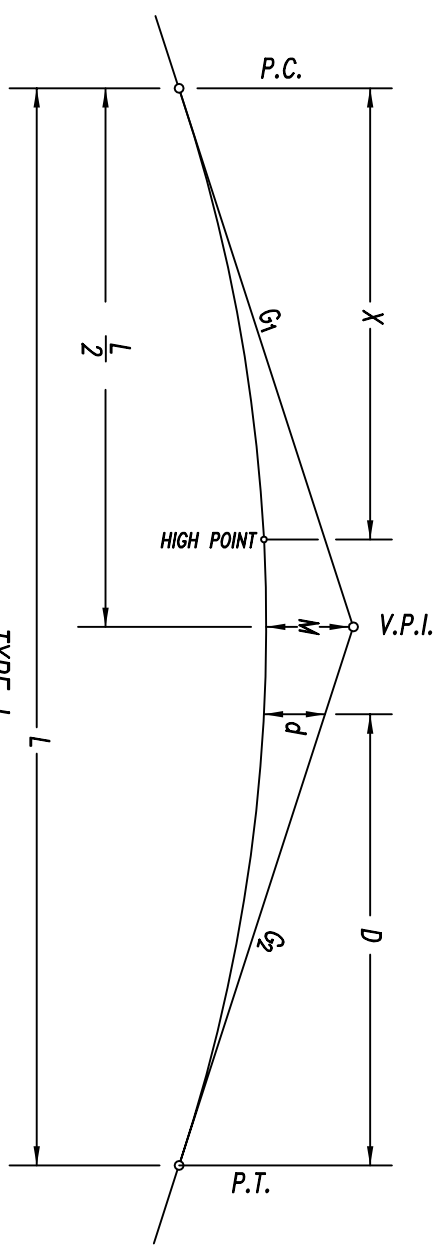

TYPE I
CREST VERTICAL CURVE

G1 & G2 = GRADES IN FT. PER 100 FT.

L = LENGTH OF CURVE IN STATIONS

$$D = 4M \left(\frac{D}{L} \right)^2 \quad \text{OR} \quad D = \frac{\text{ALGEBRAIC DIFF. } X D^2}{2L}$$

$$M = \frac{L (\text{ALGEBRAIC DIFFERENCE IN GRADES})}{8}$$

TO DETERMINE HIGH POINT (OR LOW POINT ON SAG VERTICAL)
USE THE FOLLOWING: $X = \frac{G_1 \times L}{\text{ALG. DIFF. IN GRADES}}$
WHERE X IS THE DISTANCE FROM THE P.C. OF THE CURVE IN STATIONS.

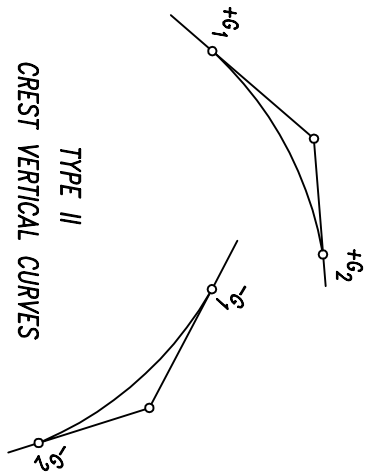

TYPE II
CREST VERTICAL CURVES

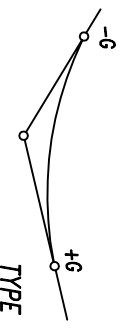

TYPE III
SAG VERTICAL CURVES

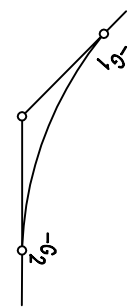

TYPE IV
SAG VERTICAL CURVES

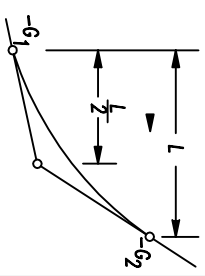

VERTICAL CURVES

HUERFANO COUNTY

APPROVED: _____
REVISED: _____
REVISED: _____

FIGURE NO.
11

9 BOLT HOLES. SIZE 2 MAILBOX REQUIRES FOUR ANGLE CONNECTORS TO ATTACH THE MAILBOX TO TYPE 3 SUPPORT. MAX. OF 4 SIZE 2 MAILBOXES.

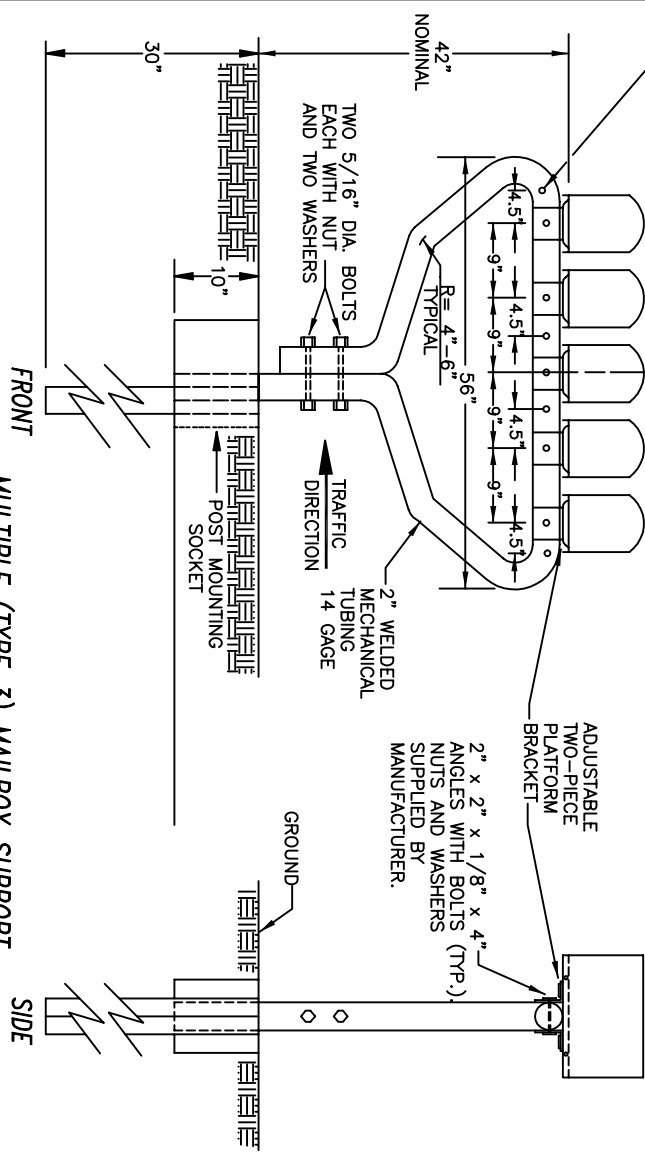

FRONT
 SIDE
MULTIPLE (TYPE 3) MAILBOX SUPPORT
 (FORESIGHT PRODUCTS MODEL NO. 20-M OR APPROVED EQUAL)

GENERAL NOTES

POSTS, BRACKETS, AND ALL MOUNTING HARDWARE SHALL BE GALVANIZED IN ACCORDANCE WITH AASHTO M 232 AND M 111, EXCEPT THE WELDED MECHANICAL TUBING SHALL BE G-90 OR EQUIVALENT PER ASTM A 525. TWO INCH OUTSIDE DIAMETER, 14 GAGE WELDED MECHANICAL TUBING SHALL CONFORM TO THE REQUIREMENTS OF ASTM A 513.

EXACT DIMENSIONS OF ANGLES, PLATFORM AND SHELF BRACKETS, BOLT HOLES, SLOTS AND MULTIPLE MAILBOX SUPPORT COMPONENTS MAY VARY FROM THOSE SHOWN OR IMPLIED HEREIN SO THAT ALL COMPONENTS WILL FIT TOGETHER PROPERLY.

PLASTIC NEWSPAPER RECEPTACLES MAY BE REMOUNTED BELOW THE MAILBOX ON THE SUPPORT.

ON ROADS WITH CURB AND GUTTER, THE MAILBOX SUPPORT SHALL BE LOCATED IN THE GROUND SO THE FRONT OF THE MAILBOX SHALL BE 8" TO 12" BACK FROM THE CURB FACE. THE HEIGHT SHALL BE 42" TO 48" MEASURED FROM THE GUTTER FLOW LINE TO THE BOTTOM OF THE MAILBOX.

ON ROADS WITH SIDEWALK ATTACHED TO CURB AND GUTTER, THE MAILBOX SUPPORT SHALL BE LOCATED IN THE GROUND BEHIND THE SIDEWALK. THE FRONT OF THE MAILBOX SHALL BE IN LINE WITH OR SLIGHTLY BEHIND THE EDGE OF THE SIDEWALK. THE MOUNTING HEIGHT SHALL BE 42" TO 48" ABOVE THE SIDEWALK.

THE GROUND SURROUNDING THE MAILBOX SUPPORTS SHALL BE FIRM, UNDISTURBED GROUND, OR WELL COMPACTED REGRADED SOIL. THE SUPPORTS ARE NORMALLY DRIVEN, BUT THEY MAY BE PLACED IN A DUG HOLE WITH WELL COMPACTED BACKFILL.

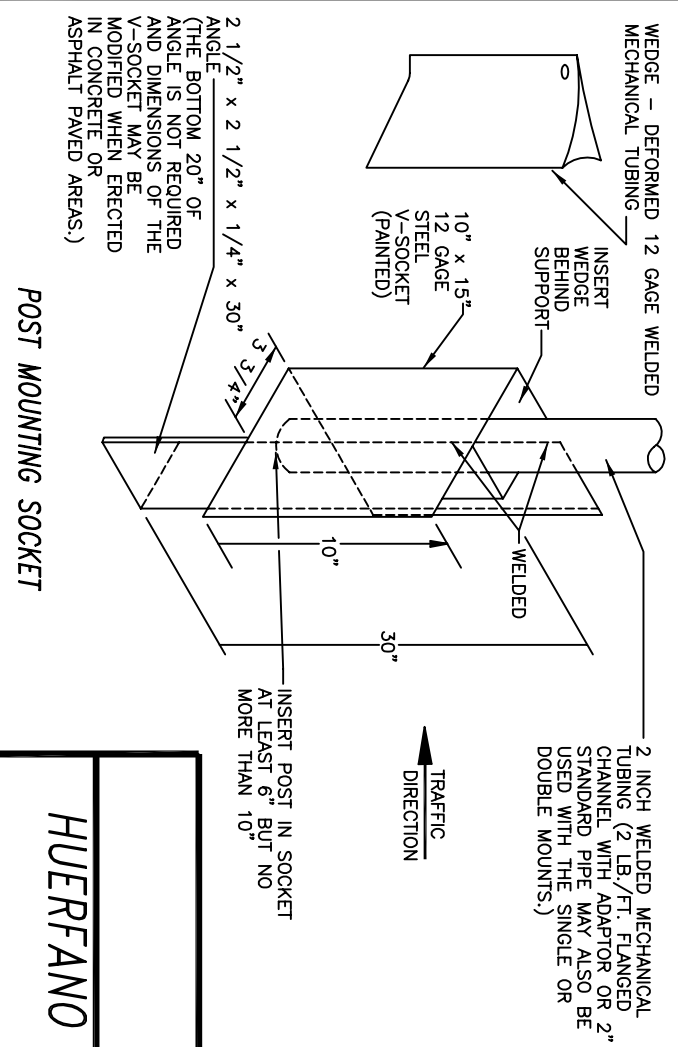

WEDGE - DEFORMED 12 GAGE WELDED MECHANICAL TUBING
 INSERT WEDGE BEHIND SUPPORT
 10" x 15" 12 GAGE STEEL V-SOCKET (PAINTED)
 2 INCH WELDED MECHANICAL TUBING (2 LB./FT. FLANGED CHANNEL WITH ADAPTOR OR 2" STANDARD PIPE MAY ALSO BE USED WITH THE SINGLE OR DOUBLE MOUNTS.)
 WELDED
 30°
 10"
 3 3/4"
 3 3/4"
 2 1/2" x 2 1/2" x 1/4" x 30" ANGLE (THE BOTTOM 20" OF ANGLE IS NOT REQUIRED AND DIMENSIONS OF THE V-SOCKET MAY BE MODIFIED WHEN ERECTED IN CONCRETE OR ASPHALT PAVED AREAS.)
 INSERT POST IN SOCKET AT LEAST 6" BUT NO MORE THAN 10"
 TRAFFIC DIRECTION

POST MOUNTING SOCKET

MAILBOX SUPPORTS

HUERFANO COUNTY

APPROVED: _____
 REVISED: _____
 REVISED: _____

FIGURE NO. 12A

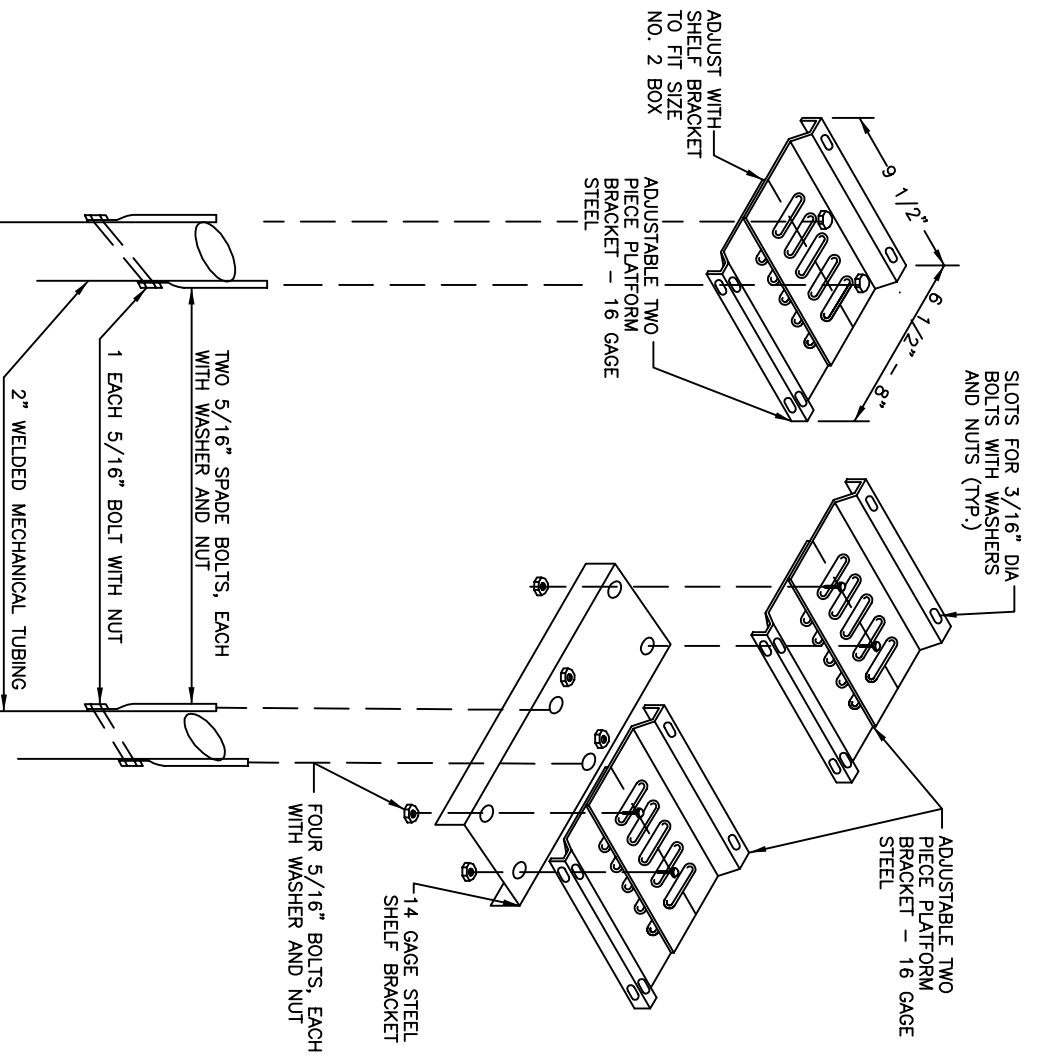

SINGLE AND DOUBLE MAILBOX SUPPORTS ALTERNATIVE
 (FORESIGHT PRODUCTS MODEL NOS. 20-S OR 20-D)

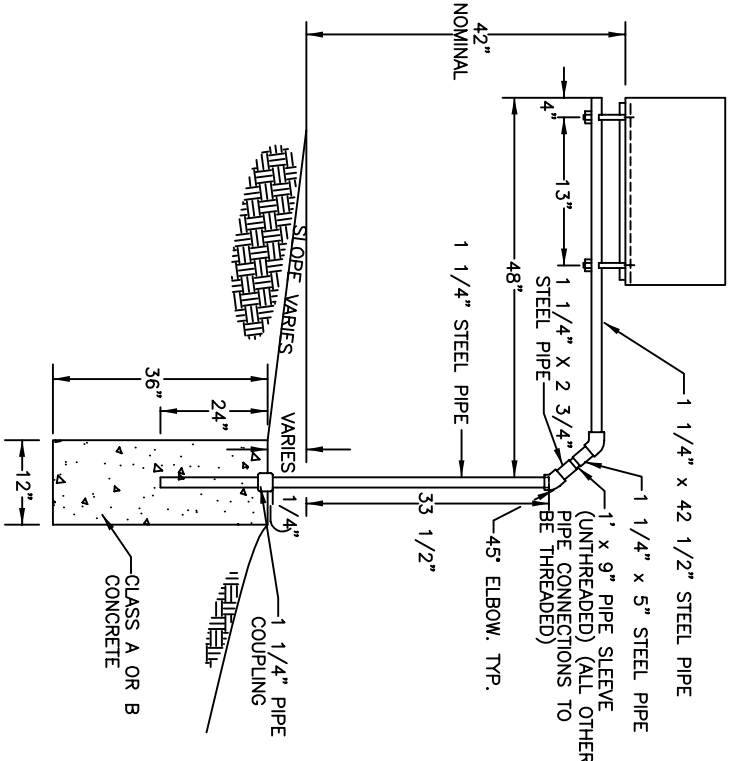

CANTILEVER (TYPE 4) MAILBOX SUPPORT

MAILBOX SUPPORTS

HUERFANO COUNTY

APPROVED: _____
 REVISED: _____
 REVISED: _____

FIGURE NO. 12B

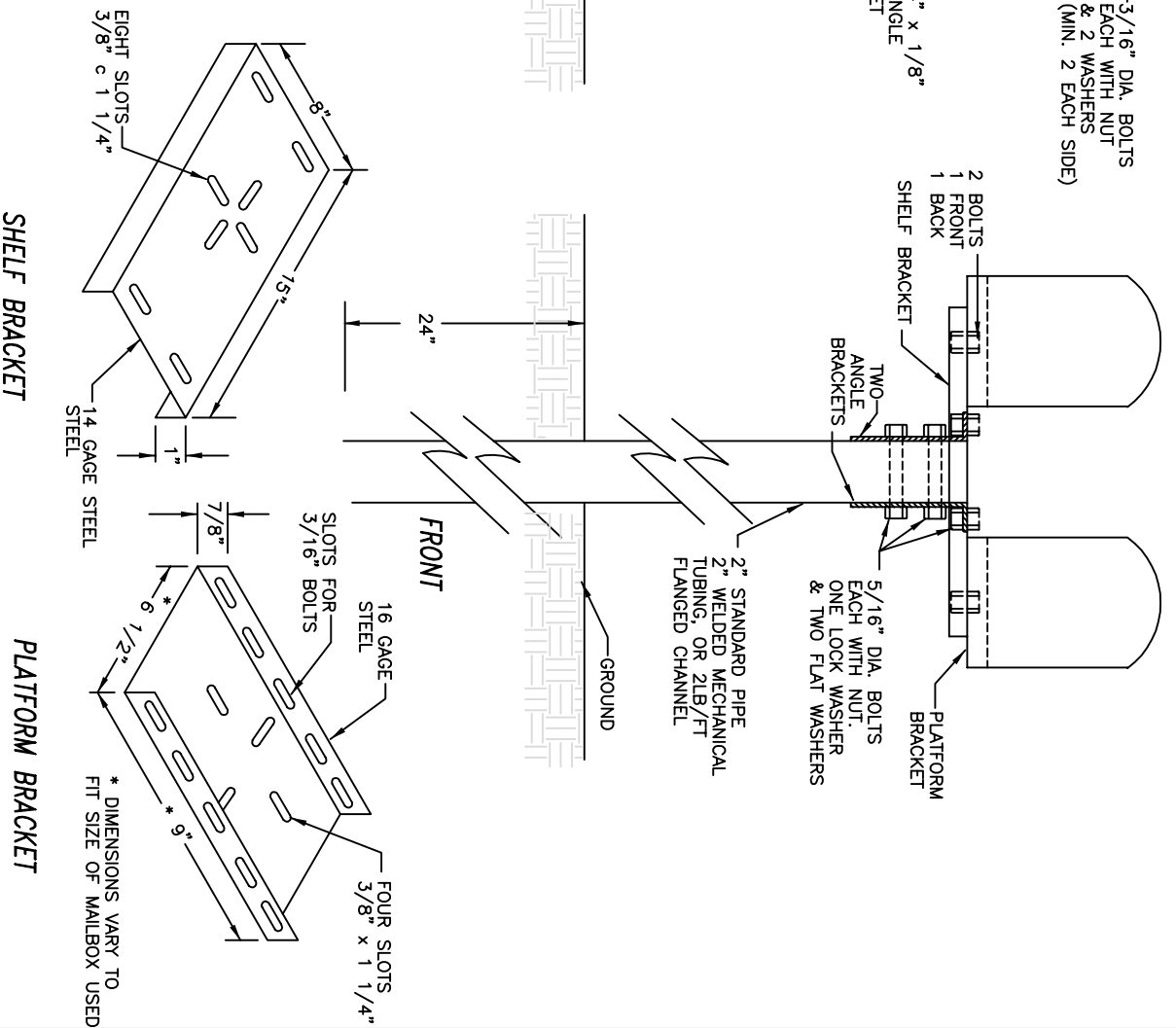
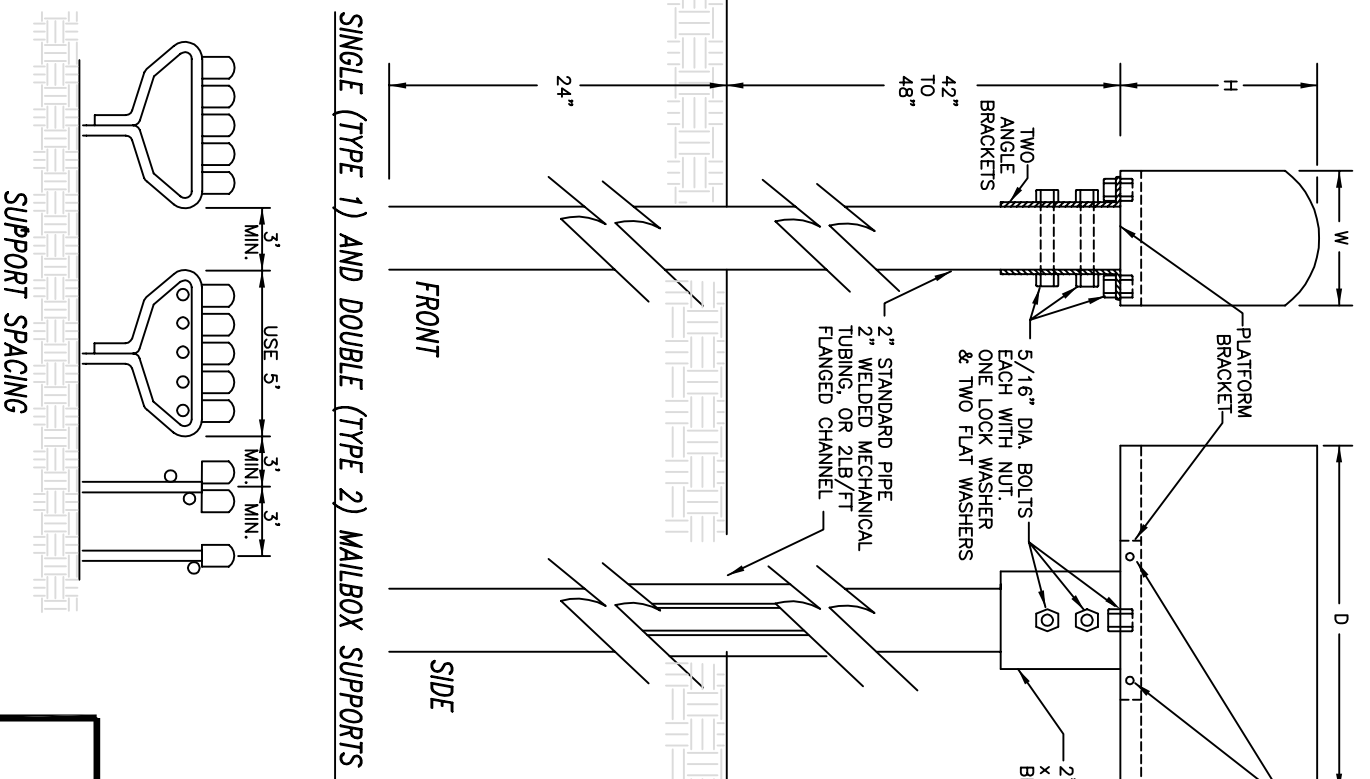

MAILBOX SUPPORTS

HUERFANO COUNTY

APPROVED: _____
 REVISED: _____
 REVISED: _____

FIGURE NO. 13

INCREASE LENGTH 3' FOR EACH ADDITIONAL MAILBOX SUPPORT, PLUS AN ADDITIONAL 5' FOR EACH SUPPORT THAT IS A MULTIPLE MAILBOX SUPPORT (EX., 2 MULTIPLE AND 1 DOUBLE: ADD 16 FEET)

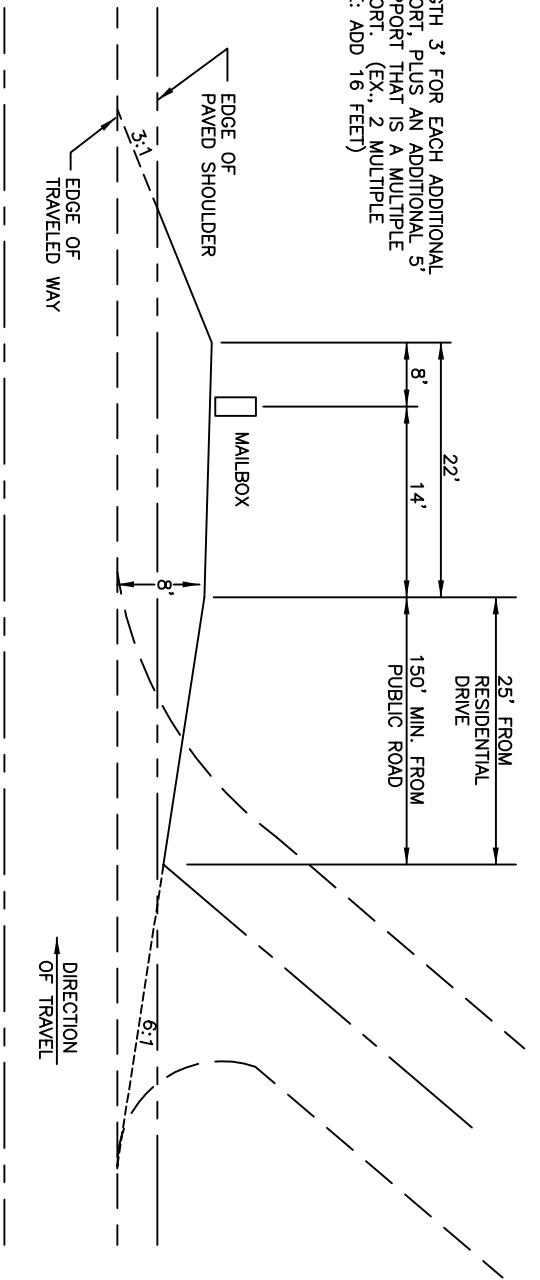

MAILBOX TURNOUT

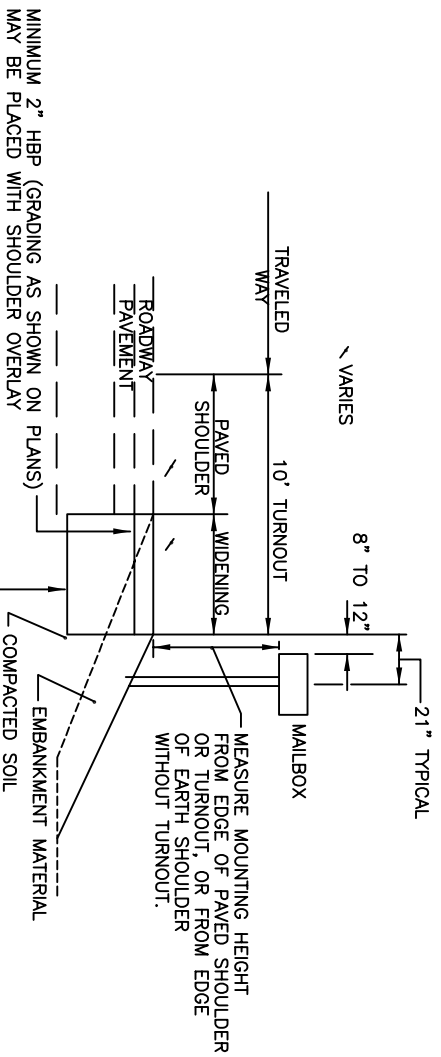

TURNOUT TYPICAL SECTION

MAILBOX TURNOUTS - ROAD ADT ≥ 2000

HUERFANO COUNTY

APPROVED: _____
 REVISED: _____
 REVISED: _____

FIGURE NO.
 14

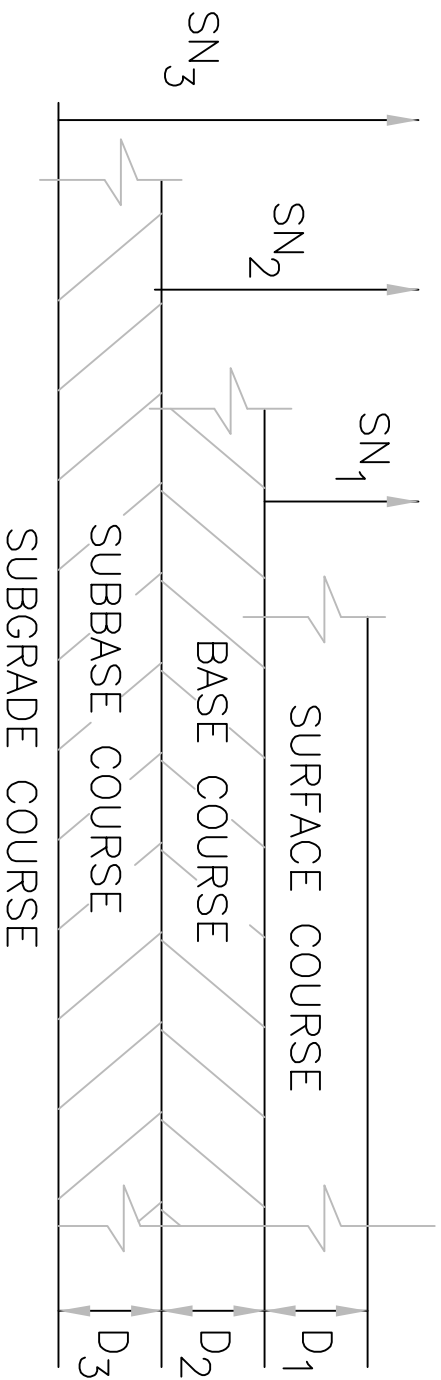

$$D^*_{1} \geq \frac{SN_1}{a_1} \quad SN^*_1 + SN^*_2 \geq SN_2$$

$$SN^*_1 = a_1 D^*_{1} \geq SN_1 \quad D^*_3 \geq \frac{SN_3 - (SN^*_1 + SN^*_2)}{a_3 m_3}$$

$$D^*_2 \geq \frac{SN_2 - SN^*_1}{a_2 m_2}$$

- 1) Where a_1 is the structural layer coefficient for each material, m_1 is drainage related adjustment per sec. 6.3e
- 2) An asterisk with D or SN indicates that it represents the value actually used, which must be equal to or greater than the required value.

LAYERED PAVEMENT DESIGN

HUERFANO COUNTY

APPROVED: _____
 REVISED: _____
 REVISED: _____

FIGURE NO.
15

NOMOGRAPH SOLVES:

$$\log_{10} 10^{18} k_{ESAL} = Z_R^* S_0 + 9.36 \log_{10} (SN+1) - 0.20 + \frac{\log_{10} \left[\frac{\Delta PSI}{4.2-1.5} \right]}{0.40 + \frac{1094}{(SN+1)^{5.19}}} + 2.32 \log_{10} M_R - 8.07$$

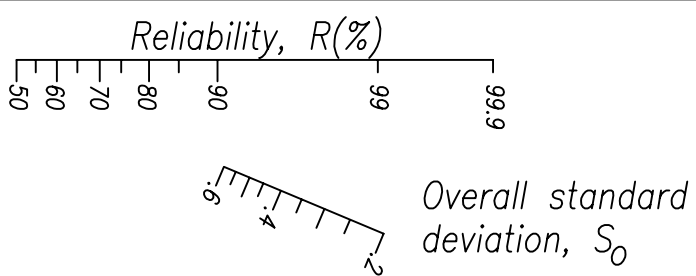

Estimated total 18-kip equivalent single axle load applications (millions)



Effective roadbed soil resilient modulus, M_R (psi)

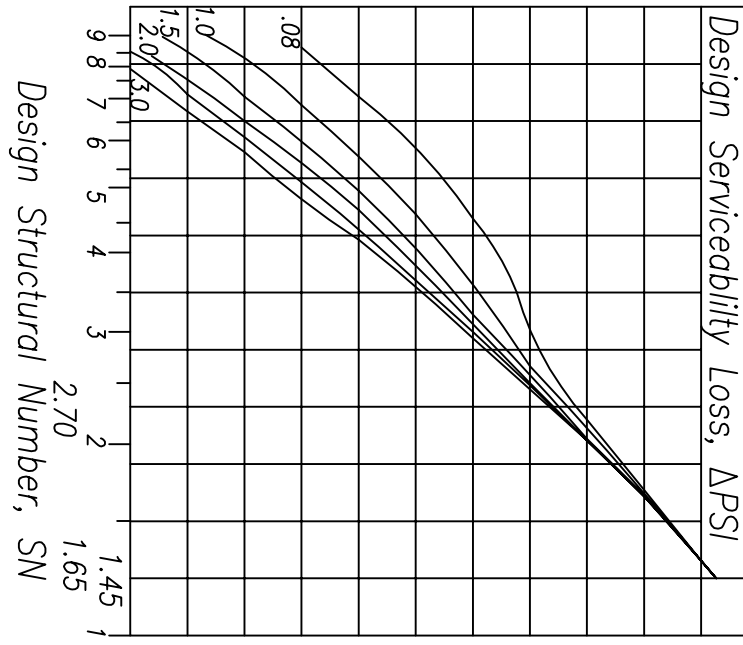
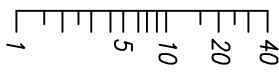

DESIGN NOMOGRAPH-FLEXIBLE PAVEMENTS

HUERFANO COUNTY

APPROVED: _____
 REVISED: _____
 REVISED: _____

FIGURE NO. 16

Evaluation of soils and pavement structure materials

Tests, material components and terms involved in the evaluation of flexible pavement design are as follows.

<u>COMPONENT</u>	<u>TEST</u>	<u>TERM</u>
Roadbed Soil	Resilient Modulus	P.S.I.
Subbase	Hveem stability	R
Base Course	Hveem stability	R
Plant Mix Bituminous	Elastic modulus	P.S.I.
Base (PMBB)	Elastic modulus	P.S.I.
Hot Bituminous	Elastic modulus	P.S.I.
Pavement (HBP)	Elastic modulus	P.S.I.
Plant Mixed Seal (PMS)	Elastic modulus	P.S.I.

Correlation of resistance values to soil support values is shown to the right.

STRUCTURAL COEFFICIENT

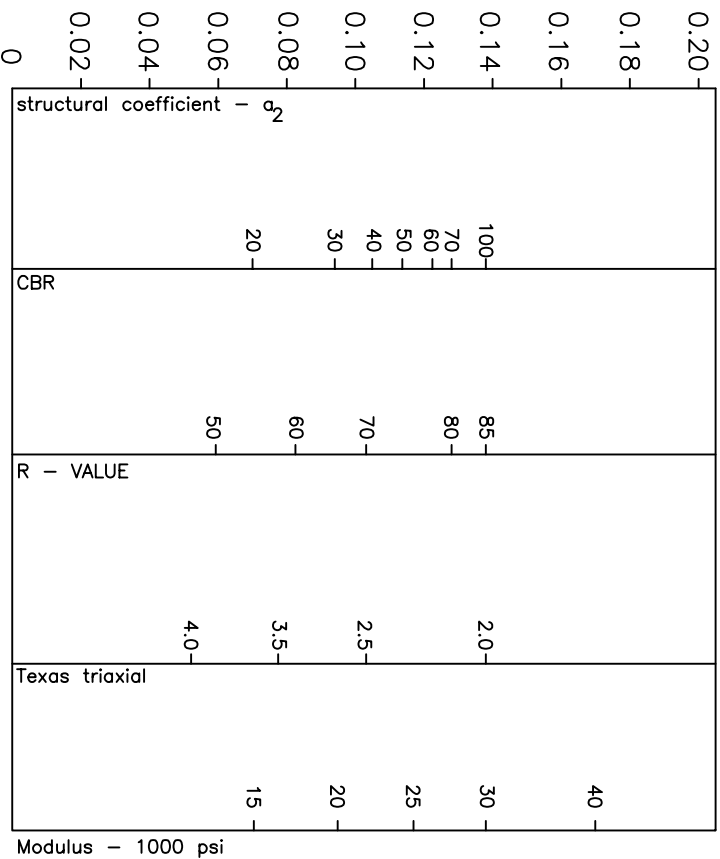

NOTE: The minimum strength coefficient of the base course on highways having a current ADT volume of 750 or greater shall be 0.12

SOIL SUPPORT VALUES

HUERFANO COUNTY

APPROVED: _____
 REVISED: _____
 REVISED: _____

FIGURE NO.
17

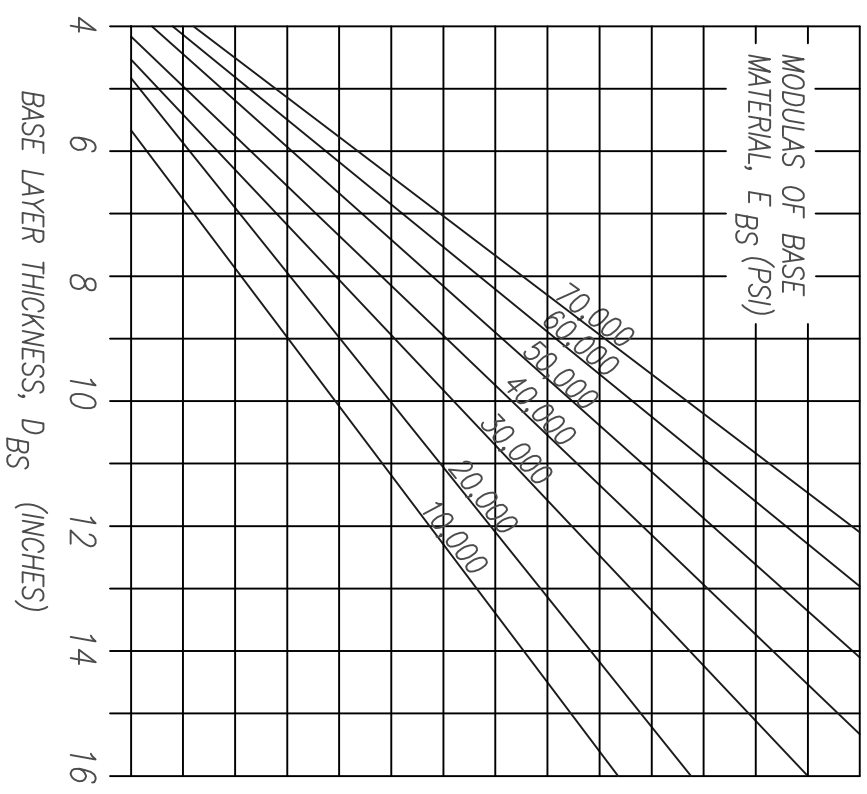
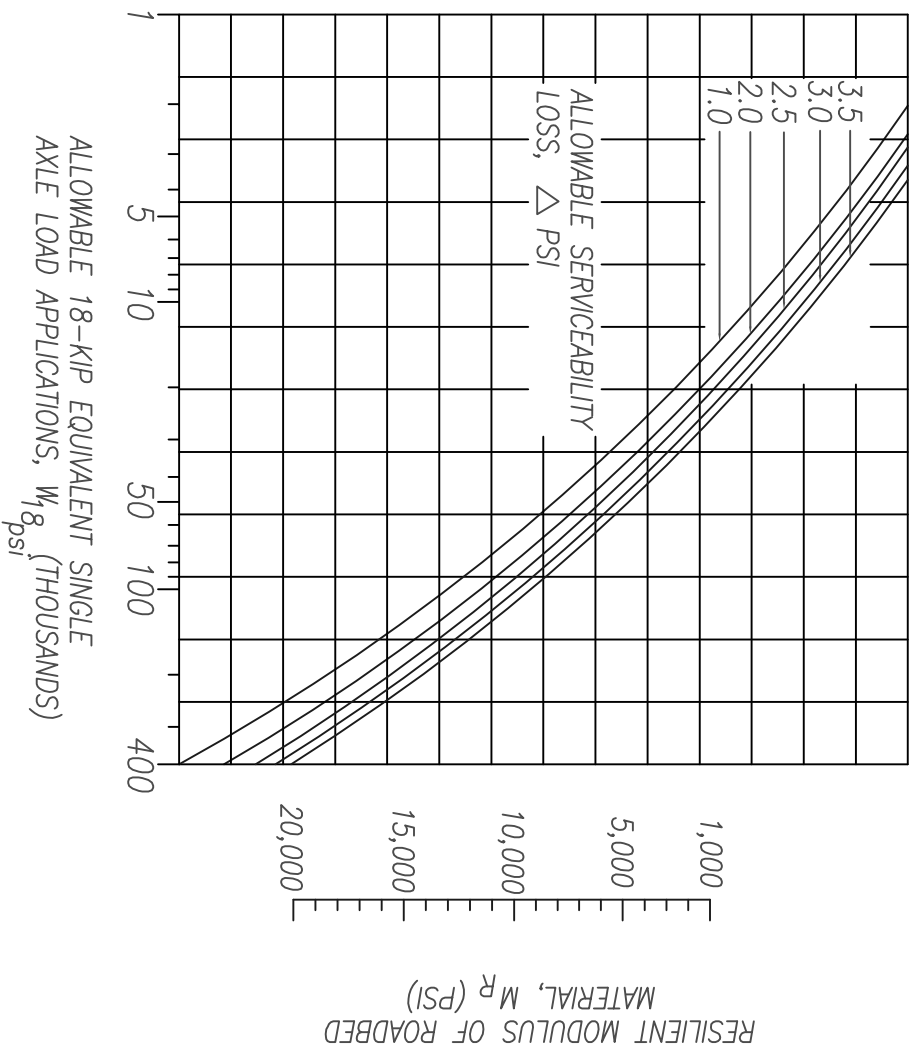

DESIGN NOMOGRAPH FOR GRAVEL ROADS - SERVICEABILITY CRITERIA

HUERFANO COUNTY

APPROVED: _____
 REVISED: _____
 REVISED: _____

FIGURE NO. 18

Allowable 18 kip equivalent
single axle load applications,
 W_{18RUT} (thousands)

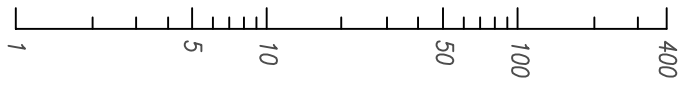

Modulus of aggregate base
layer, E_{BS} (psi)

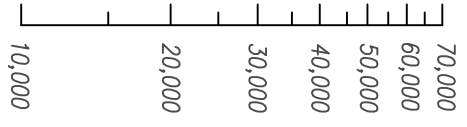

Resilient modulus of roadbed
material, M_R (psi)

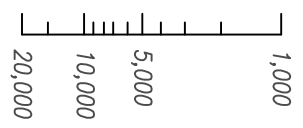

Allowable rut depth, RD (inches)



Thickness of aggregate base layer considered
for rutting criteria, D_{BS} (inches)

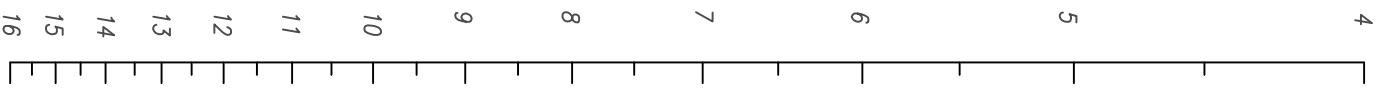

DESIGN NOMOGRAPH FOR GRAVEL ROADS -
RUTTING CRITERIA

HUERFANO COUNTY

APPROVED: _____
REVISED: _____
REVISED: _____

FIGURE NO.
19

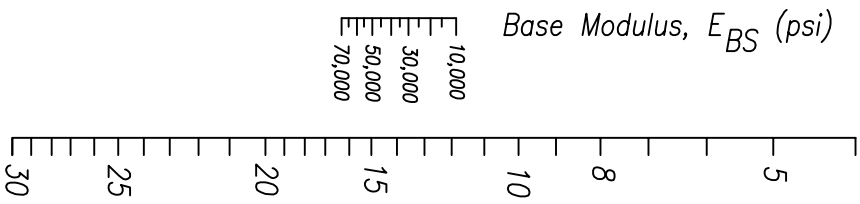
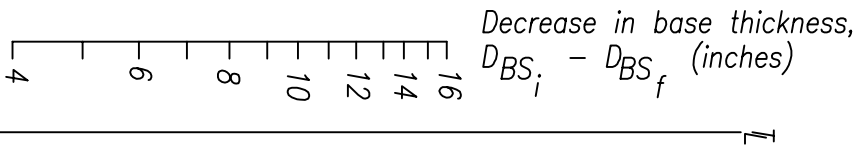
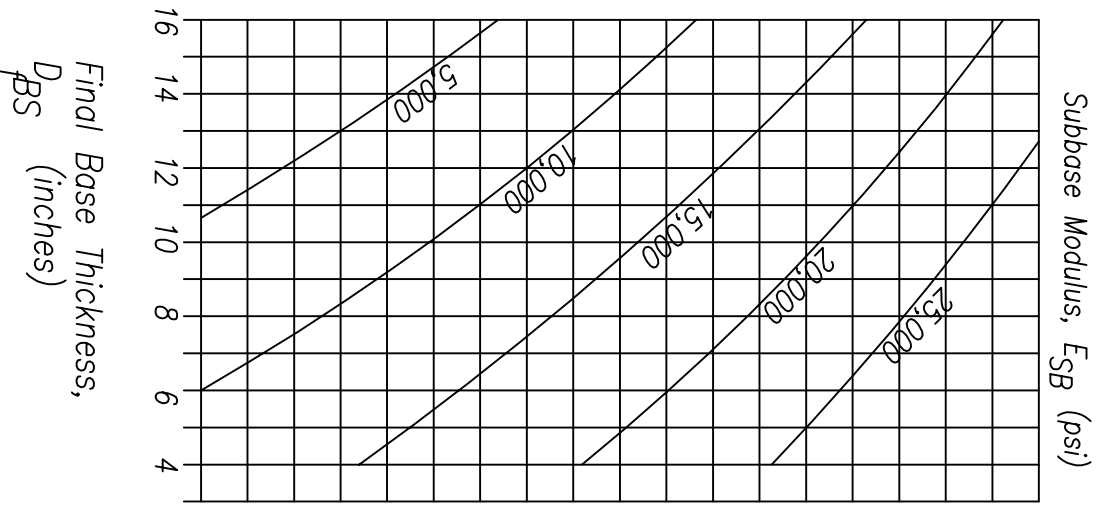

Required subbase thickness, D_{SB} (inches)

EQUIVALENT THICKNESS - SUBBASE VS BASE

HUERFANO COUNTY

APPROVED: _____
 REVISED: _____
 REVISED: _____

FIGURE NO.
 20

R.O.W.

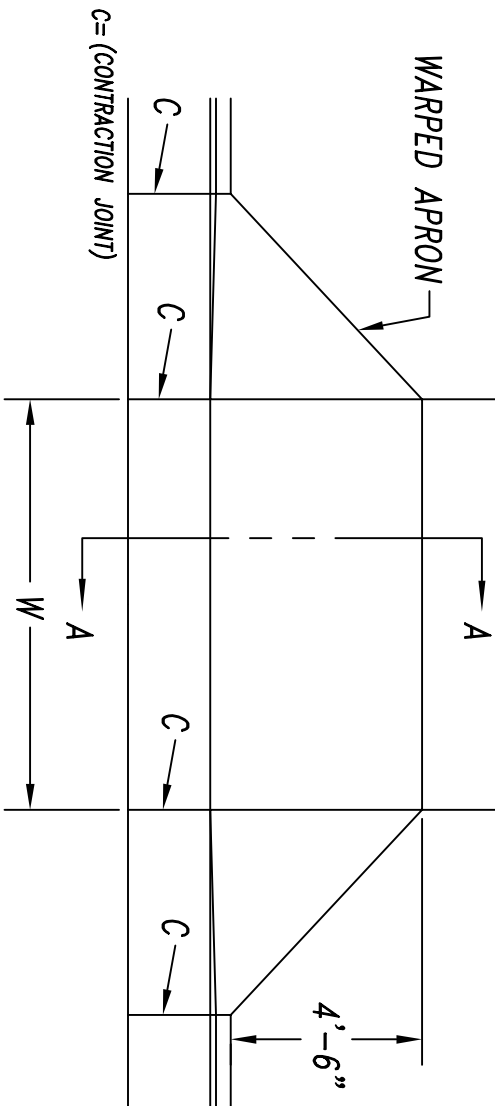

NOTE: CONCRETE SHALL EXTEND 4'-6" OR TO BACK OF SIDEWALK (IF PRESENT)

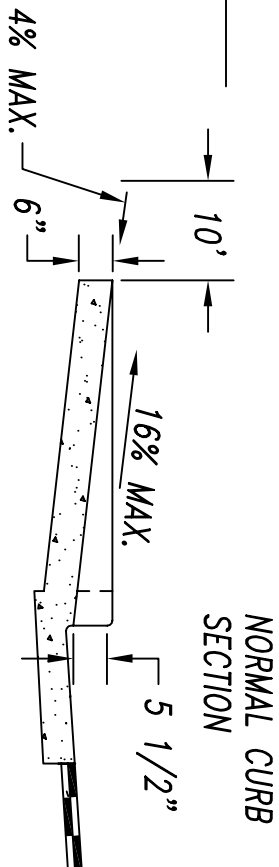

4% MAX.
2% MIN.

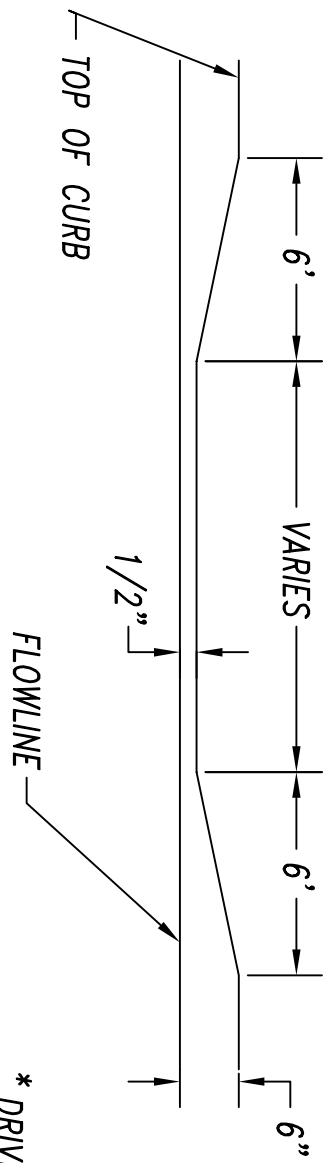

TYPICAL CURB CUT SECTION

* DRIVES OVER 30' MAY REQUIRE CONSTRUCTION AS A ROAD APPROACH WITH CURB RETURNS AND CROSS PAN.

URBAN DRIVEWAY WIDTHS	
MIN.	MAX.
RESIDENTIAL 12'	20'
COMMERCIAL 20'	30'*

SECTION A-A

URBAN DRIVEWAYS

HUERFANO COUNTY

APPROVED: _____
 REVISED: _____
 REVISED: _____

FIGURE NO. 21

RURAL DRIVEWAY WIDTHS		
USE	W, MIN.	W, MAX.
RESIDENTIAL	12'	18'
MULTI-FAMILY RESIDENCE	16'	24'
COMMERCIAL	16'	24'
INDUSTRIAL	24'	30'
AGRICULTURAL	16'	30'

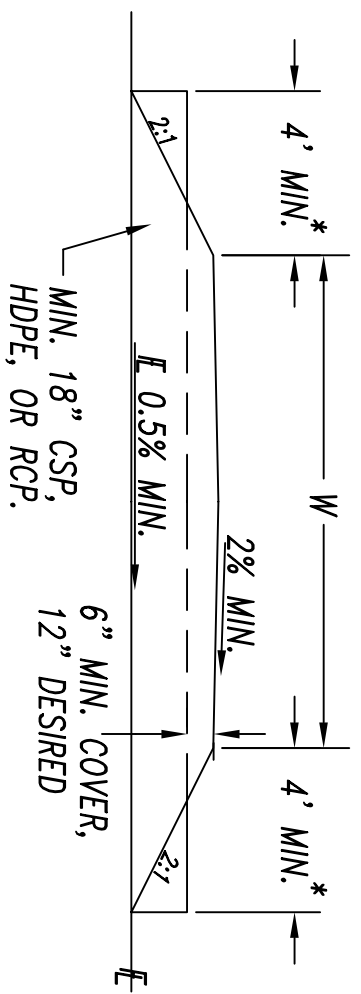
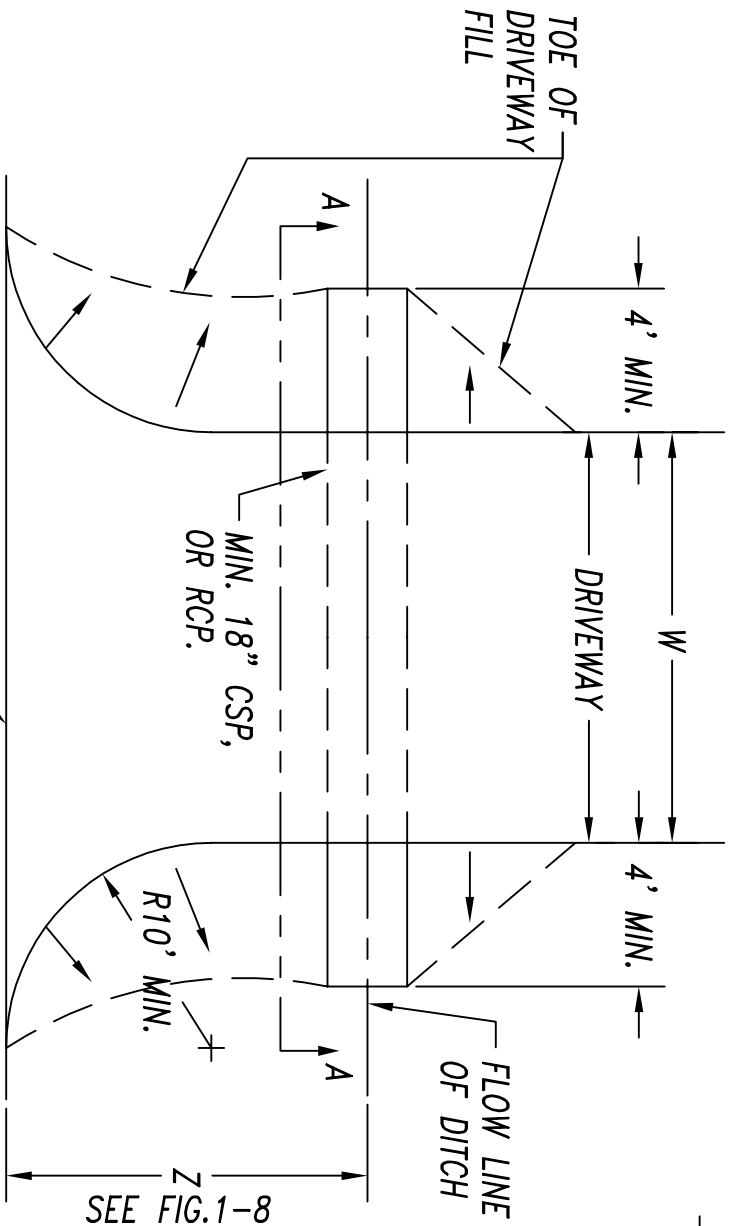

SECTION A-A

*SEE FIGURES 25 & 26 FOR END TREATMENT DETAILS

NOTES:

1. For driveways along paved roadways, the driveway shall be paved from the roadway edge to the property line with grade C H.B.P., min. 4" depth.
2. For driveways along gravel roadways, the driveway shall be capped from the roadway edge to the property line with class 6 A.B.C., min. 9" depth.

SEE FIG. 1-8

RURAL DRIVEWAYS

HUERFANO COUNTY

APPROVED: _____
 REVISED: _____
 REVISED: _____

FIGURE NO. 22

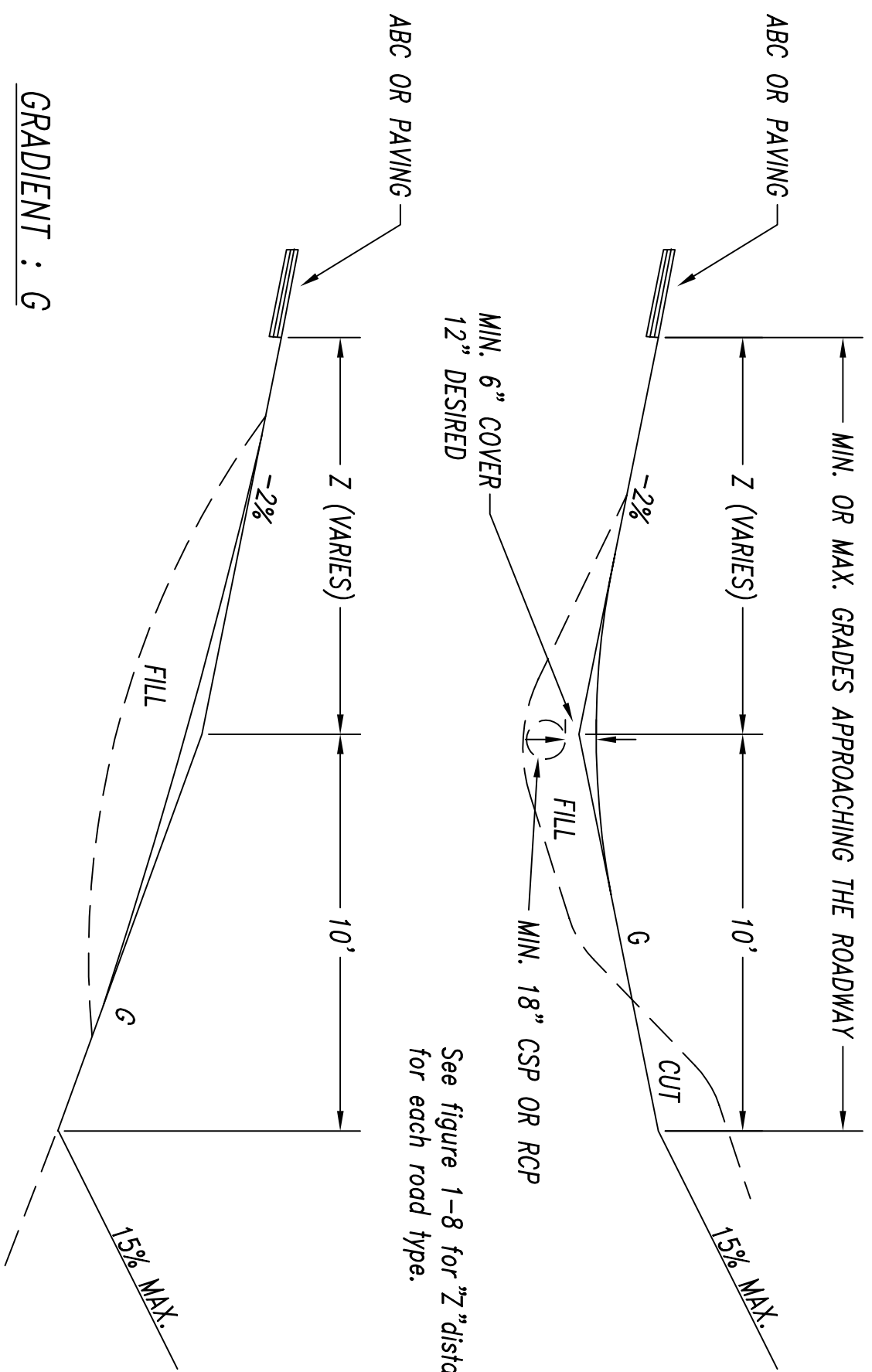

See figure 1-8 for "Z" distance for each road type.

GRADIENT : G

- Commercial 2% min. to 8% max.
- Industrial 2% min. to 5% max.
- Residential 2% min. to 15% max.
- Agricultural 2% min. to 15% max.

RURAL DRIVEWAY PROFILES	
HUERFANO COUNTY	
APPROVED: _____	FIGURE NO. _____
REVISED: _____	23
REVISED: _____	

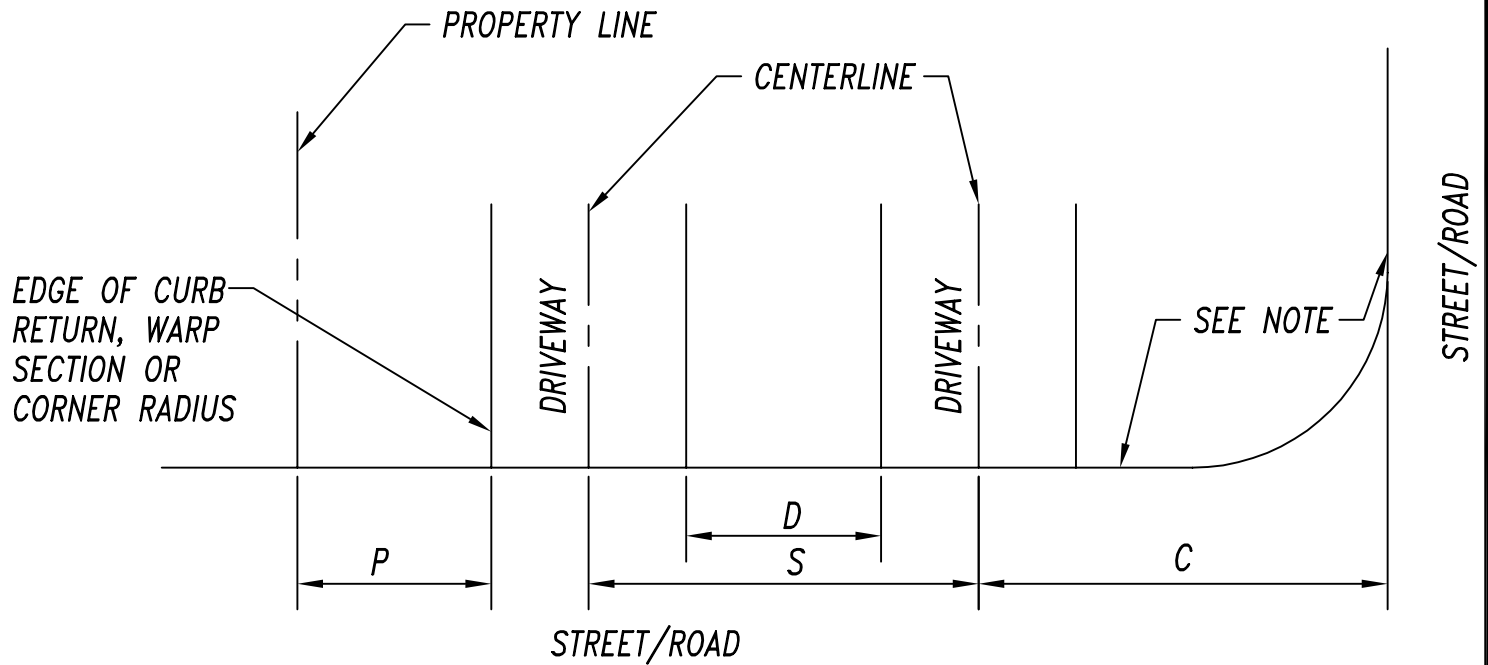

NOTE: Flowline of curb/gutter or edge of asphalt if curb/gutter does not exist or edge of shoulder if asphalt does not exist.

	Figure Reference	Dimension
Residential Driveways		
From property lines	P	5' *
From street/road intersection	C	60' **
Between driveways		
on locals	D	10'
on collectors	S	200'
on arterials	S	325'
Non-residential Driveways on Locals		
From property lines	P	5' *
From arterial street intersections	C	200' ***
From collector street intersections	C	100' ***
From local street intersections	C	60' ***
Between driveways	S	100' ***
Non-residential Driveways on Collectors		
From property lines	P	5' *
From arterial street intersections	C	300' ***
From collector street intersections	C	200' ***
From local street intersections	C	125' ***
Between driveways	S	150' ***
Non-residential Driveways on Arterials		
From property lines	P	5' *
From street intersections	C	500' ****
Between driveways	S	325' ***

* Except at shared access locations

** The C dimension may be reduced to 30 feet if stop sign control is provided at the street intersection.

*** The C and S dimensions may be reduced if approved by the Board of County Commissioner due to the existence of limiting factors. Selected turning movements may be prohibited.

**** If the proposed driveway is restricted to right turn movements or if it is not aligned with an existing or planned left-turn lane, the C dimension may be reduced if approved by the Director of Public Works due to the existence of limiting factors. If signalization is proposed, the minimum C distance shall be increased to 660 feet unless otherwise approved by the Board of County Commissioners.

DRIVEWAY SPACING

HUERFANO COUNTY

APPROVED: _____
 REVISED: _____
 REVISED: _____

FIGURE NO.
 24

APPENDIX 1 STANDARD DETAILS

Figure 25

Culvert Headwalls - Pipes smaller than 48 inches in diameter Amendment:

If spiral pipe is used flared end sections shall be placed on both the inlet and outlet of the culvert pipe. Delineator posts shall be installed at each end of the flared end sections.

If the County inspector feels deviation from the current application depicted in Figure 25 would not be acceptable, they may deny the applicant's request. The applicant may dispute the inspectors' decision before the Board of County Commissioners.

Appendix 1 Standard Details Figure 25-Amended by Resolution #16- 47
on May 10, 2016

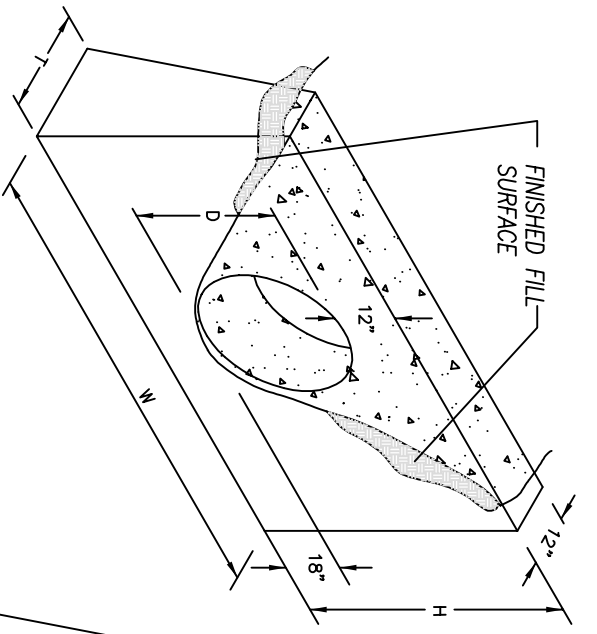

SINGLE PIPE
N.T.S.

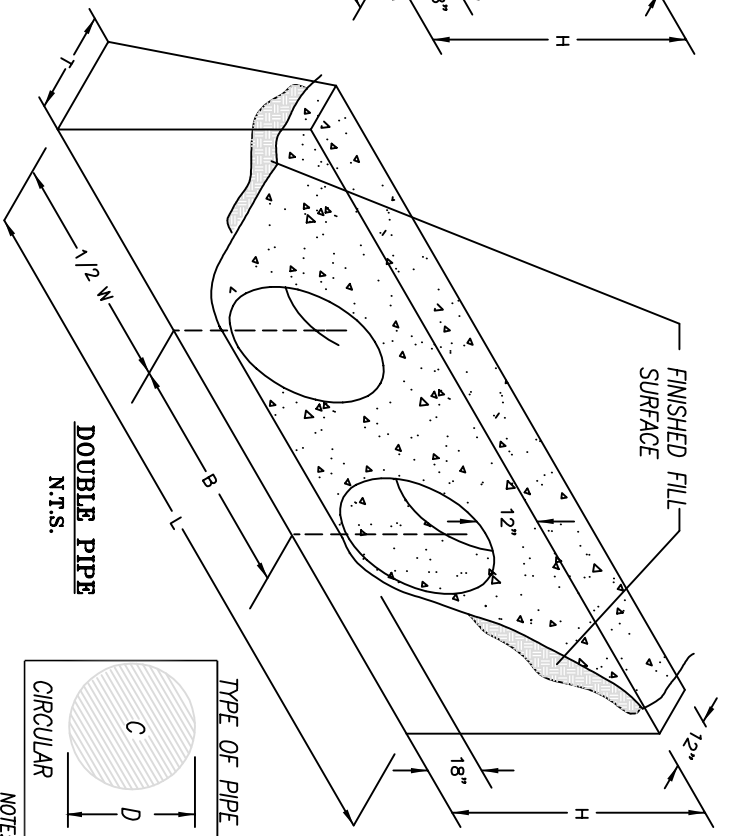

DOUBLE PIPE
N.T.S.

TYPE OF PIPE	HEADWALL DIMENSIONS
CIRCULAR	$D = \text{PIPE DIAMETER (INSIDE)}$
	$H = D + 30"$
	$W = 3D + 18"$
	$T = 0.4H$ (NEAREST INCH)
	$B = 1.5D$ (30" MINIMUM)
	$L = W + B$

NOTE: HEADWALLS FOR PIPE 48 INCHES OR LARGER IN DIAMETER MUST BE DESIGNED BY LICENSED ENGINEER SEE ART. 5.18.

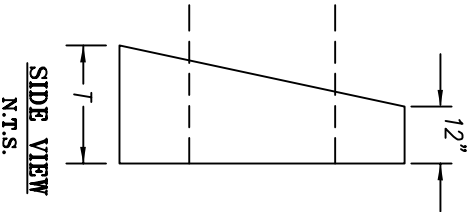

SIDE VIEW
N.T.S.

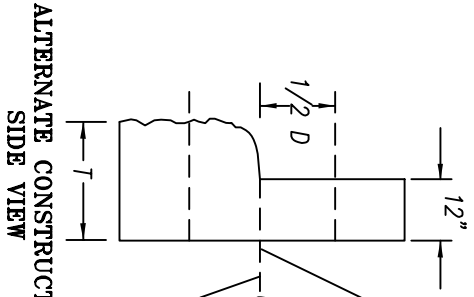

ALTERNATE CONSTRUCTION
SIDE VIEW
N.T.S.

BACK FORMED ABOVE THIS POINT.
BACK MAY BE POURED TO EXCAVATION WITH NO FORMS BELOW THIS POINT.

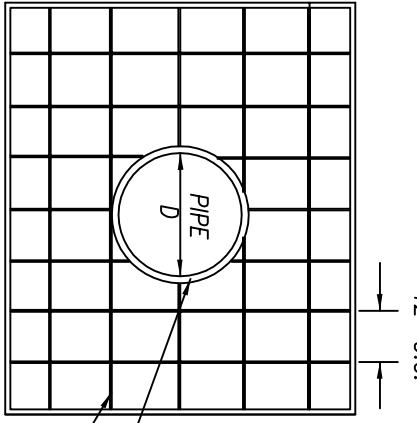

12" O.C.
18" O.C.
4" CLEAR
#4 REBAR (TYP.)

GENERAL NOTES

FOR SIZE AND LOCATION OF CULVERTS, SEE PLANS.
ALL CONCRETE SHALL BE CLASS A OR B.
FOOTINGS IN ROCK SHALL BE POURED OUT TO ROCK AND NOT FORMED
EXPOSED CONCRETE CORNERS SHALL BE CHAMFERED 3/4"

CULVERT HEADWALLS - PIPES SMALLER THAN 48 INCH DIAMETER.

HUERFANO COUNTY

APPROVED: _____
REVISED: _____
REVISED: _____

FIGURE NO. 25

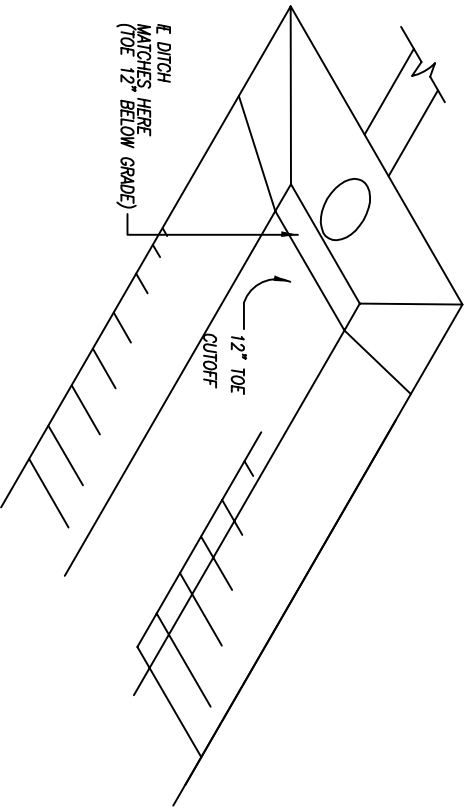
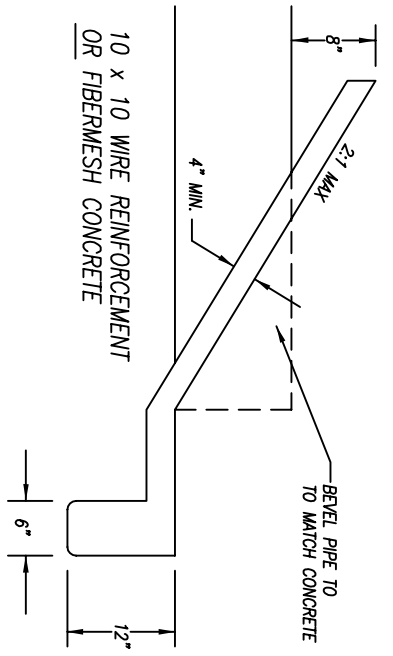

ISOMETRIC VIEW

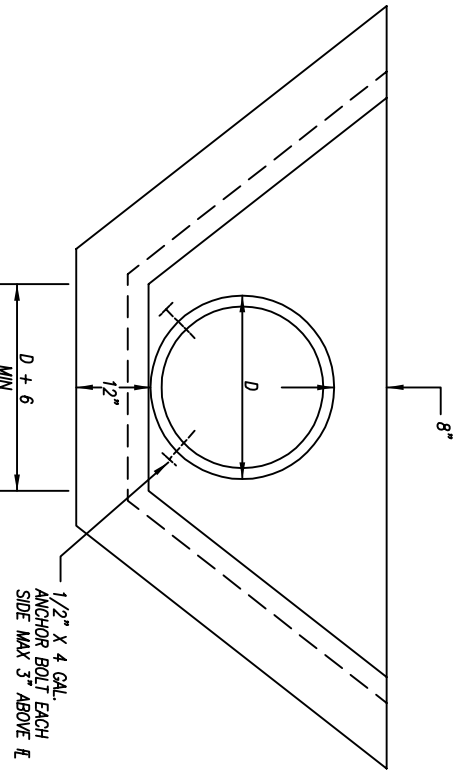

FRONT VIEW

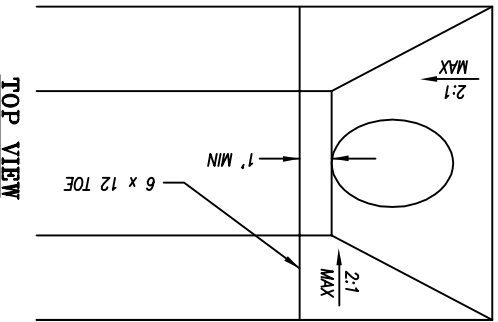

TOP VIEW

CULVERT INLET/OUTLET PAVING

HUERFANO COUNTY

APPROVED: _____
REVISID: _____
REVISID: _____

FIGURE NO.
26

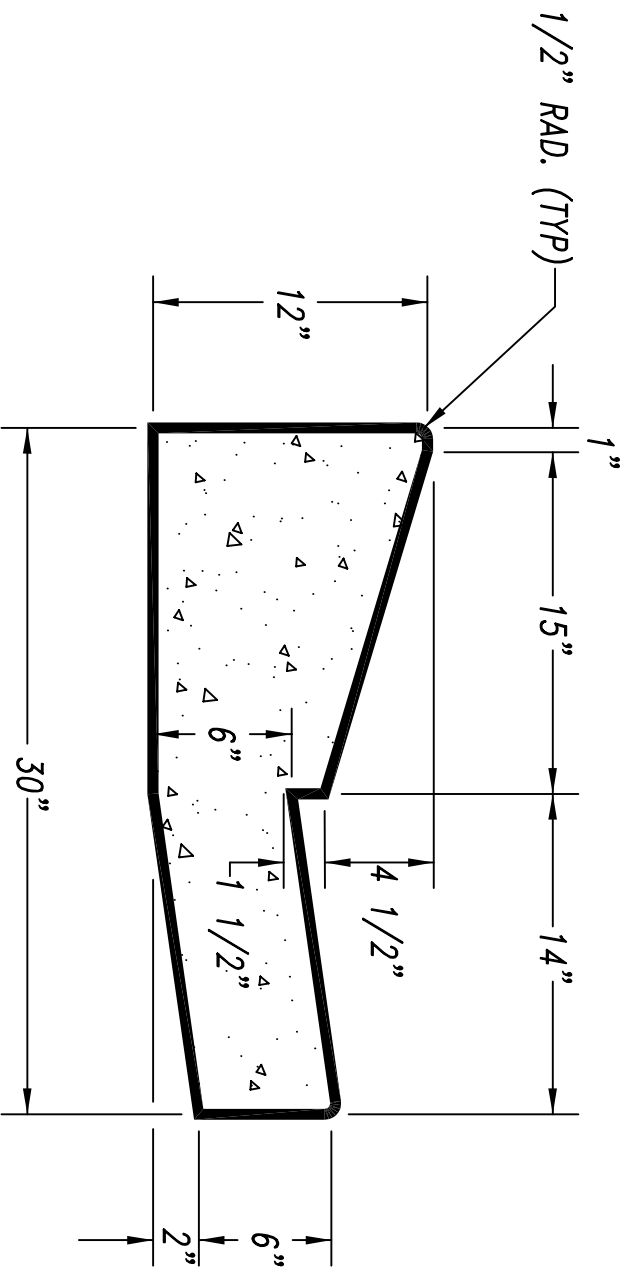

TYPICAL X-SECTION
NOT TO SCALE

ALTERNATE RAMP CURB & GUTTER

HUERFANO COUNTY

APPROVED: _____
 REVISED: _____
 REVISED: _____

FIGURE NO.
27

APPENDIX 2

Tables

APPENDIX 2

TABLE 1

Class	min. r.o.w.	design capacity A.D.T.	design speed	grade		allowed surface
				min.	max.	
Expressway	150	20--50,000	60	0.5	6	pave.
Principal Arterial	120	12--28,000	60	0.5	6	pave.
Minor Arterial	100	5--10,000 two lane 10--18,000 four lane	50	0.5	6	pave.
Major Collector	80	2--5,000	45	0.5	8	pave.
Minor Collector	60	1250--2500	40	0.5	8	pave.
Local Access	60	500--1250	30	0.5	10	pave.
Local Minor Residential	60	0--500	30	0.5	10	pave. gravel*
Local Industrial	70	0--1250	30	0.5	8	pave.
Local Commercial	70	0--1250	30	0.5	6	pave.

* subject to the restrictions and conditions listed in Article 6

TABLE 2

TRIAL BASE THICKNESS, D_{BS} (INCHES) _____				SERVICEABILITY CRITERIA PSI=		RUTTING CRITERIA RD(INCHES)=	
(1) SEASON (ROADBED MOISTURE CONDITION)	(2) ROADBED RESILIENT MODULUS M_R (psi)	(3) BASE ELASTIC MODULUS E_{BS} (psi)	(4) PROJECTED 18 -- KIP ESAL TRAFFIC W_{18}	(5) ALLOWABLE 18 -- KIP ESAL TRAFFIC $(W_{18})_{PSI}$	(6) SEASONAL DAMAGE $W_{18}/(W_{18})_{PSI}$	(7) ALLOWABLE 18 -- KIP ESAL TRAFFIC $(W_{18})_{RUT}$	(8) SEASONAL DAMAGE $W_{18}/(W_{18})_{RUT}$
WINTER (FROZEN)							
SPRING/THAW (SATURATED)							
SPRING/FALL (WET)							
SUMMER (DRY)							
		TOTAL TRAFFIC =		TOTAL DAMAGE =		TOTAL DAMAGE=	

APPENDIX 3

**ASPHALT PAVEMENT AND
GRAVEL ROAD DESIGN EXAMPLES**

ASPHALT PAVEMENT

As an example to illustrate the procedure and requirements of Article 6, assume the following:

- o Minor collector functional classification
- o HVEEM test R value of 20
- o Projected traffic volume equivalent to the minimum 18K EDLA value of 30 for a minor collector

From the equations in 6.2 c:

$$S_1 = [(20-5)/11.29] + 3 = 4.33$$

$$M_R = 10^{(S_1 + 18.72)/6.24} = 4898 \text{ (use 5000)}$$

Convert EDLA to ESAL (20 year design period)

$$30 \times 20 \times 365 = 219,000$$

From 6.3 c , the reliability factor for a minor collector is 80

From Figure 17 in Appendix 1:

Modulus for base course with structural coefficient of 0.12 is approximately 26,000.

Modulus for subbase course with structural coefficient of 0.10 is approximately 21,000.

From the nomograph in Figure 16 of Appendix 1 (reproduced to illustrate example as Figure A3 - 1, this Appendix) read the following structural numbers for layered design per Figure 15:

$$SN_1 = 1.45$$

$$SN_2 = 1.65$$

$$SN_3 = 2.7$$

Per the procedure described in 6.5 and illustrated in Figure 15:

$$D^*_1 = SN_1/a_1 = 1.45/0.44 = 3.3; \text{ use } 3.5$$

$$SN^*_1 = a_1 D^*_1 = SN_1 = (3.5)(0.44) = 1.54$$

$$D^*_2 = SN_2 - SN^*_1/a_2 m_2 = (1.65 - 1.54)/0.12 = 1; \text{ use } 6 \text{ inch min.}$$

$$SN^*_1 + SN^*_2 = SN_2 = (0.12)(6) + (3.5)(0.44) = 2.26; > 1.65 \text{ ok}$$

$$D^*_3 = SN_3 - (SN^*_1 + SN^*_2)/a_3m_3 = (2.7 - 2.26)/0.10 = 4.4; \text{ use } 5$$

$$\text{total} = SN^*_1 + SN^*_2 + SN^*_3 = 1.54 + 0.72 + 0.50 = 2.76 > 2.7 \text{ ok}$$

Therefore use the following layer thickness:

Depth of HBP (D^*_1) - 3.5 inches

Depth of Class 6 base course (D^*_2) - 6 inches

Depth of Class 2 subbase course (D^*_3) - 5 inches

The above would be the minimum allowed values.

If a full depth asphalt design were proposed for this example (and APPROVED by the Public Works Director) the required depth would be:

$$D_{\text{fda}} = SN_3/a_1 = 2.7/0.44 = 6.14; \text{ use } 6.5 \text{ inches}$$

GRAVEL ROAD DESIGN

The primary design requirements for aggregate surfaced roads include:

- o Predicted future traffic for the design period (see Article 2)
- o The lengths of the seasons (see Article 6.6.1e)
- o Seasonal resilient moduli of the roadbed soil (see Article 6.6.1f)
- o Elastic modulus, E_{BS} (psi), of aggregate base layer (from HVEEM or other testing. M_R value)
- o Elastic modulus, E_{BS} (psi), of aggregate subbase layer (from HVEEM or other testing. M_R value)
- o Design serviceability loss, ΔPSI (Article 6.6.1c)
- o Allowable rutting, RD (inches), in surface layer (Article 6.6.1a), and
- o Aggregate loss, GL (inches), of surface layer (Article 6.6.1b)

These design requirements are used in conjunction with the computational chart in Table 2 in Appendix 2 and the design nomographs for serviceability (Figure 18, Appendix 1) and rutting (Figure 19, Appendix 1) The following steps outline the procedure:

Step 1: Select four levels of aggregate base thickness, D_{BS} , which should bound the probable solution. Prepare four separate tables, one for each trial thickness, identical to Table 2. On each of the four tables enter the trial base thickness, D_{BS} ; design serviceability loss, ? PSI; and the allowable rutting, RD in the appropriate boxes.

Step 2: Enter the appropriate seasonal resilient (elastic) moduli of the roadbed (M_R) and the aggregate base material, E_{BS} , in columns 2 and 3, respectively, of Table 2. The base modulus values may be proportional to the resilient modulus of the roadbed soil during a given season. However, a constant value of 30,000 psi was used in the example which follows since a portion of the aggregate base material will

be converted into an equivalent thickness of subbase material (which will provide some shield against the environmental moisture effects).

Step 3: Enter the seasonal 18-kip ESAL traffic in column 4 of Table 2. Assuming that truck traffic is distributed evenly throughout the year, the lengths of the seasons should be used to proportion the total projected 18-kip ESAL traffic to each season. If the road is load-zoned (restricted) during certain critical periods, the total traffic may be distributed only among those seasons when truck traffic is allowed. Total traffic of 36,500 18-kip ESAL applications (the minimum 5 EDLA and a 20 year design period) and a seasonal pattern corresponding to U.S. Climatic Region VI was used in the example.

Step 4: Within each of the four tables estimate the allowable 18-kip ESAL traffic for each of the four seasons using the serviceability-based nomograph (Figure 18) and enter the result in column 5. If the resilient modulus of the roadbed soil (during the frozen season) is such that the allowable traffic exceeds the upper limit of the nomograph, assume a practical value of 500,000 18-kip ESAL.

Step 5: Within each of the four tables estimate the allowable 18-kip ESAL traffic for each of the four seasons using the rutting-based nomograph (Figure 19) and enter the result in column 7. Again, if the resilient modulus of the roadbed soil is such that the allowable traffic exceeds the upper limit of the nomograph, assume a practical value of 500,000 18-kip ESAL.

Step 6: Compute the seasonal damage values in each of the four tables for the serviceability criteria by dividing the projected seasonal traffic (column 4) by the allowable traffic in that season (column 5). Enter these seasonal damage values in column 6 of Table 2 corresponding to serviceability criteria. Next, follow these same instructions for rutting criteria, i.e., divide column 4 by column 7 and enter in column 8.

Step 7: Compute the total damage for both the serviceability and rutting criteria by adding the seasonal damages. When this is accomplished for all four tables, a graph of total damage versus base layer thickness should be prepared. The average base layer thickness, \underline{D}_{BS} , required is determined by interpolating in this graph for a total damage equal to 1.0. Figure A3-5 provides an example in which the design is controlled by the serviceability criteria.

Step 8: The base layer thickness determined in the last step should be used for design if the effects of aggregate loss are negligible. If, however, aggregate loss is significant, the design thickness is determined using the following equation:

$$D_{BS} = \underline{D}_{BS} + (0.5 \times GL)$$

where GL = total estimated aggregate (gravel) loss (in inches) over the performance period.

Step 9: The final step of the design chart procedure for aggregate surfaced roads is to convert a portion of the aggregate base layer thickness to an equivalent thickness of subbase material. This is accomplished with the aid of Figure 20. Select the final base thickness desired, D_{BSf} (6 inches is used in the example). Draw a line to the estimated modulus of the subbase material, E_{BS} . Go across and through the scale corresponding to the reduction in base thickness, $D_{BSi} - D_{BSf}$. Then for the known modulus of the base material, E_{BS} , determine the required subbase thickness, D_{SB} .

As an example to illustrate the described procedure and the requirements of Article 6, assume the following:

- o HVEEM R value of 20 for the roadbed soil.
- o The minimum required EDLA of 5, over a 20 year design period for a total traffic of 36,500 18-kip ESAL.

Assume 6, 8, 10, and 12 inches of base thickness for preparation of the four tables. Per Article 6.6.1, the design serviceability loss is 3, and the allowable rutting is 2.

Proportion the total projected 18-kip ESAL traffic into the seasonal traffic values for column 4 according to the lengths of season specified in 6.6.1e.

The results of proceeding according to steps 4, 5, and 6 above are shown in the example tables, Tables A3-1 through A3-4.

Figure A3-5 shows the graph of total damage versus base layer thickness for this example. The serviceability criteria require a larger thickness of base than the rutting criteria. Use the higher value (11.6 inches) for design.

Gravel loss is specified for design purposes in 6.6.1b as 2 inches, therefore the required thickness, D_{BS} , is:

$$D_{BS} = \underline{D}_{BS} + (0.5 \times GL) = 11.6 + (0.5 \times 2) = 12.6 \text{ inches.}$$

Use Figure 20 (reproduced showing the example as Figure A3-4) to determine the amount of subbase material required to reduce the base thickness by 6 inches.

TABLE 2a -- EXAMPLE ASSUMING 6 INCHES BASE COURSE

TRIAL BASE THICKNESS, D_{BS} (INCHES) <u>6</u>				SERVICEABILITY CRITERIA		RUTTING CRITERIA	
				PSI = <u>3</u>		RD (INCHES) <u>2</u>	
(1)	(2)	(3)	(4)	(5)	(6)	(7)	(8)
SEASON (ROADBED MOISTURE CONDITION)	ROADBED RESILIENT MODULUS M_R (psi)	BASE ELASTIC MODULUS E_{BS} (psi)	PROJECTED 18 -- KIP ESAL TRAFFIC W_{18}	ALLOWABLE 18 -- KIP ESAL TRAFFIC $(W_{18})_{PSI}$	SEASONAL DAMAGE $W_{18}/(W_{18})_{PSI}$	ALLOWABLE 18 -- KIP ESAL TRAFFIC $(W_{18})_{RUT}$	SEASONAL DAMAGE $W_{18}/(W_{18})_{RUT}$
WINTER (FROZEN)	20,000	30,000	9,125	32,000	0.29	350,000	0.03
SPRING/THAW (SATURATED)	1,500	30,000	4,563	2,200	2.07	3,500	1.30
SPRING/FALL (WET)	3,300	30,000	9,125	5,000	1.83	4,500	2.03
SUMMER (DRY)	4,900	30,000	13,687	7,000	1.96	7,500	1.82
		TOTAL		TOTAL		TOTAL	
		TRAFFIC =	36,500	DAMAGE =	6.15	DAMAGE =	5.18

TABLE 2b -- EXAMPLE ASSUMING 8 INCHES BASE COURSE

TRIAL BASE THICKNESS, D_{BS} (INCHES) <u>8</u>				SERVICEABILITY CRITERIA		RUTTING CRITERIA	
				PSI = <u>3</u>		RD (INCHES) <u>2</u>	
(1)	(2)	(3)	(4)	(5)	(6)	(7)	(8)
SEASON (ROADBED MOISTURE CONDITION)	ROADBED RESILIENT MODULUS M_R (psi)	BASE ELASTIC MODULUS E_{BS} (psi)	PROJECT ED 18 -- KIP ESAL TRAFFIC W_{18}	ALLOWABLE 18 -- KIP ESAL TRAFFIC $(W_{18})_{PSI}$	SEASONAL DAMAGE $W_{18}/(W_{18})_{PSI}$	ALLOWABLE 18 -- KIP ESAL TRAFFIC $(W_{18})_{RUT}$	SEASONAL DAMAGE $W_{18}/(W_{18})_{RUT}$
WINTER (FROZEN)	20,000	30,000	9,125	70,000	0.13	400,000	0.02
SPRING/THAW (SATURATED)	1,500	30,000	4,563	4,200	1.09	7,000	0.65
SPRING/FALL (WET)	3,300	30,000	9,125	12,000	0.76	11,000	0.83
SUMMER (DRY)	4,900	30,000	13,687	13,500	1.01	16,000	0.86
		TOTAL		TOTAL		TOTAL	
		TRAFFIC =	36,500	DAMAGE =	2.99	DAMAGE =	2.36

TABLE 2c -- EXAMPLE ASSUMING 10 INCHES BASE COURSE

TRIAL BASE THICKNESS, D_{BS} (INCHES) <u>10</u>				SERVICEABILITY CRITERIA		RUTTING CRITERIA	
				PSI = <u>3</u>		RD (INCHES) <u>2</u>	
(1)	(2)	(3)	(4)	(5)	(6)	(7)	(8)
SEASON (ROADBED MOISTURE CONDITION)	ROADBED RESILIENT MODULUS M_R (psi)	BASE ELASTIC MODULUS E_{BS} (psi)	PROJECT ED 18 -- KIP ESAL TRAFFIC W_{18}	ALLOWABLE 18 -- KIP ESAL TRAFFIC $(W_{18})_{PSI}$	SEASONAL DAMAGE $W_{18}/(W_{18})_{PSI}$	ALLOWABLE 18 -- KIP ESAL TRAFFIC $(W_{18})_{RUT}$	SEASONAL DAMAGE $W_{18}/(W_{18})_{RUT}$
WINTER (FROZEN)	20,000	30,000	9,125	120,000	0.08	400,000	0.02
SPRING/THAW (SATURATED)	1,500	30,000	4,563	8,000	0.57	11,000	0.41
SPRING/FALL	3,300	30,000	9,125	20,000	0.46	21,000	0.43

L (WET)							
SUMMER (DRY)	4,900	30,000	13,687	28,000	0.49	28,000	0.49
		TOTAL		TOTAL		TOTAL	
		TRAFFIC =	36,500	DAMAGE =	1.60	DAMAGE =	1.35

TABLE 2d -- EXAMPLE ASSUMING 12 INCHES BASE COURSE

TRIAL BASE THICKNESS, D_{BS} (INCHES) <u>12</u>				SERVICEABILITY CRITERIA PSI = <u>3</u>		RUTTING CRITERIA RD (INCHES) <u>2</u>	
(1)	(2)	(3)	(4)	(5)	(6)	(7)	(8)
SEASON (ROADBED MOISTURE CONDITION)	ROADBED RESILIENT MODULUS M_R (psi)	BASE ELASTIC MODULUS E_{BS} (psi)	PROJECTED 18 -- KIP ESAL TRAFFIC W_{18}	ALLOWABLE 18 -- KIP ESAL TRAFFIC $(W_{18})_{PSI}$	SEASONAL DAMAGE $W_{18}/(W_{18})_{PSI}$	ALLOWABLE 18 -- KIP ESAL TRAFFIC $(W_{18})_{RUT}$	SEASONAL DAMAGE $W_{18}/(W_{18})_{RUT}$
WINTER (FROZEN)	20,000	30,000	9,125	200,000	0.05	400,000	0.02
SPRING/THAW (SATURATED)	1,500	30,000	4,563	18,000	0.25	22,000	0.21
SPRING/FALL (WET)	3,300	30,000	9,125	30,000	0.30	31,000	0.29
SUMMER (DRY)	4,900	30,000	13,687	40,000	0.34	45,000	0.30
		TOTAL		TOTAL		TOTAL	
		TRAFFIC =	36,500	DAMAGE =	0.82	DAMAGE =	1.35

MEMORANDUM SOLUTION

$$\log_{10} \Delta PSI = 7.0 H_2 + 0.36 \log_{10} (SN+1) - 0.20 + \frac{\log_{10} \left[\frac{\Delta PSI}{4.2-1.5} \right] + 2.32 \log_{10} M_R - 0.07}{0.40 + \frac{1094}{(SN+1)^{5.19}}}$$

VALUES USED
 P=20
 M_R=5000
 ASSUME AASHTO DATA
 FOR LABOR COLLECTION

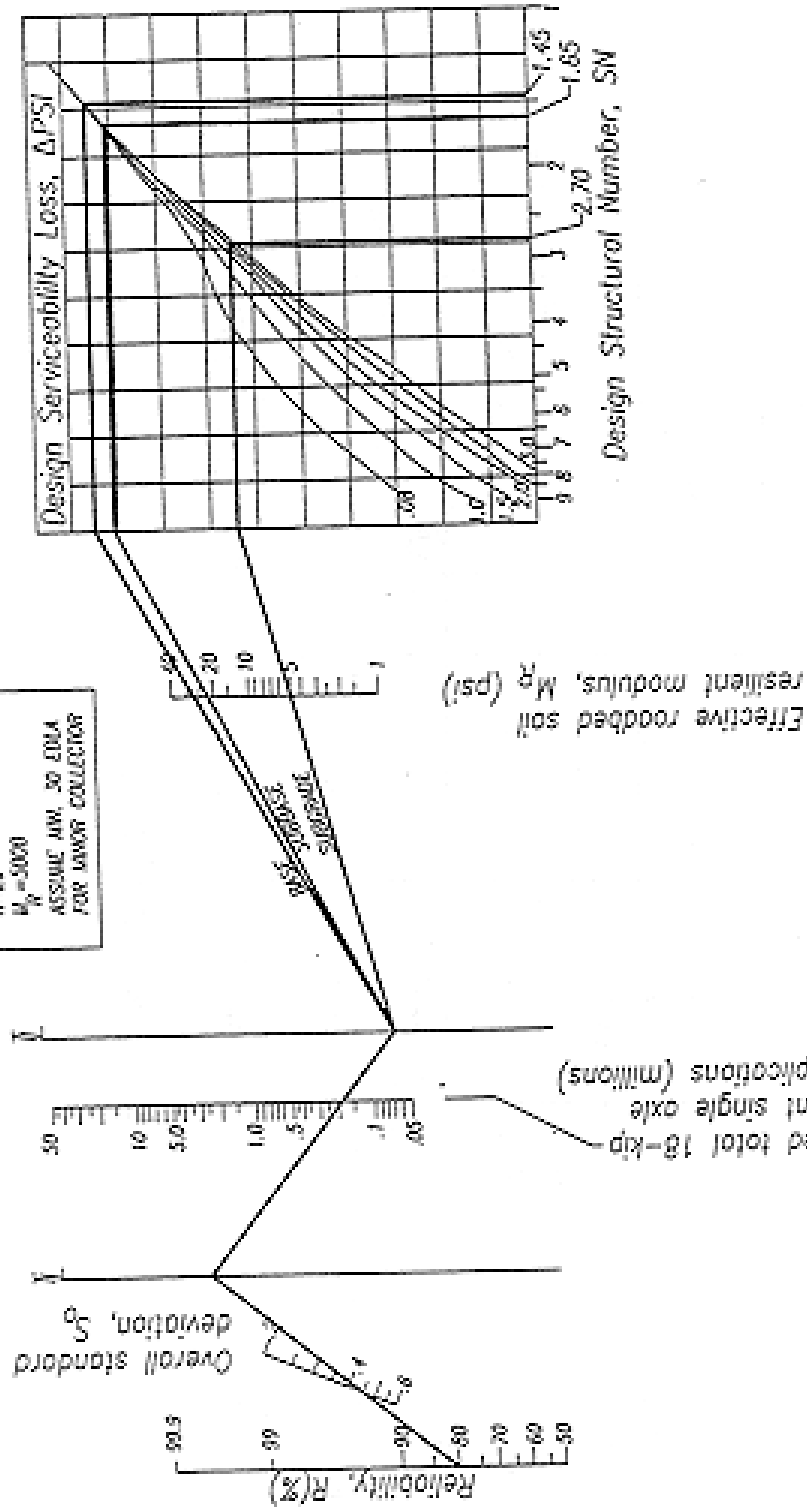

DESIGN NOMOGRAPH-FLEXIBLE PAVEMENTS

PUEBLO COUNTY PUBLIC WORKS	APPROVED: 4-23-99 REVISED: _____ REVISED: _____	FIGURE NO. A3-1
-------------------------------	---	--------------------

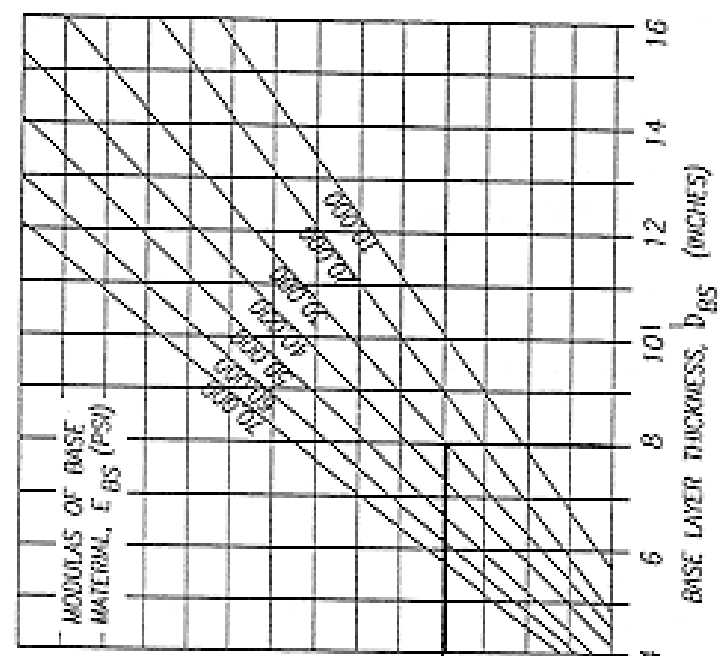

EXAMPLE:
 $D_{BS} = 0.0$ INCHES
 $E_{BS} = 30,000$ PSI
 $M_R = 5,000$ PSI
 $\Delta_{PSI} = 3.0$
 SOLUTION $W_{18_{PSI}} = 18,000$

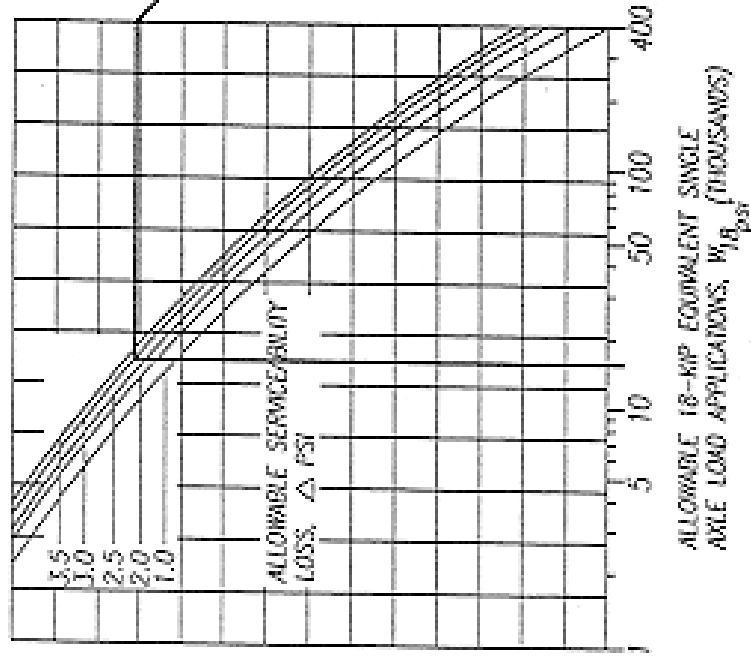

DESIGN NOMOGRAPH FOR GRAVEL ROADS - SERVICEABILITY CRITERIA	
PUEBLO COUNTY PUBLIC WORKS	APPROVED: 4-25-98 REVISED: REVISED:
FIGURE NO. A3-2	

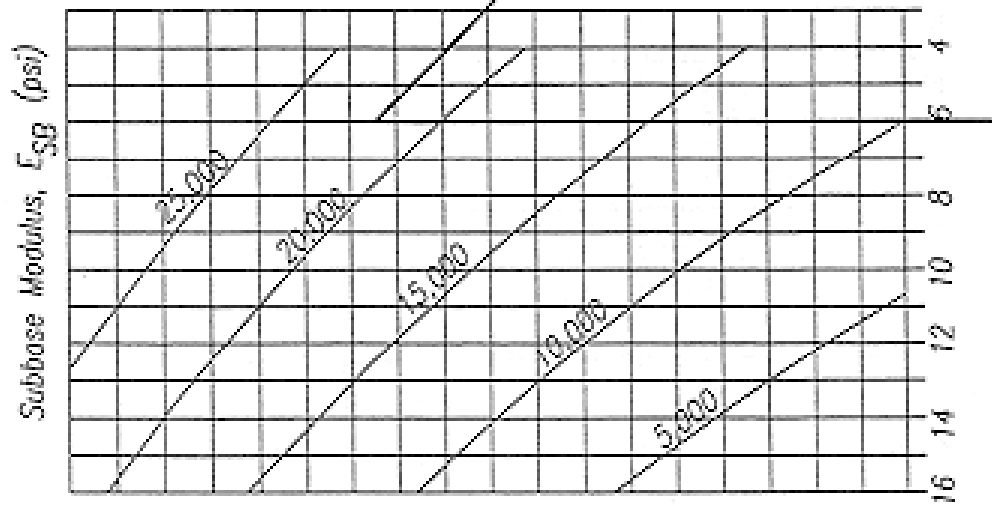

Decrease in base thickness, $D_{BS_i} - D_{BS_f}$ (inches)

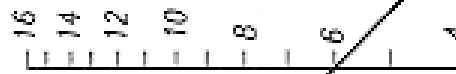

Base Modulus, E_{BS} (psi)

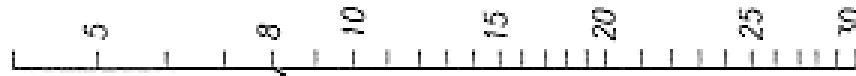

EXAMPLE:

- $D_{BS} = 12.0$ INCHES
- $D_{BS_f} = 6.0$ INCHES
- $E_{BS} = 30,000$ PSI
- $E_{SG} = 21,000$ PSI

SOLUTION: $D_{SG} = 8.0$ INCHES

EQUIVALENT THICKNESS - SUBBASE VS BASE

PUEBLO COUNTY
PUBLIC WORKS

FIGURE NO.

A3-4

Final Base Thickness,
 D_{BS_f} (inches)

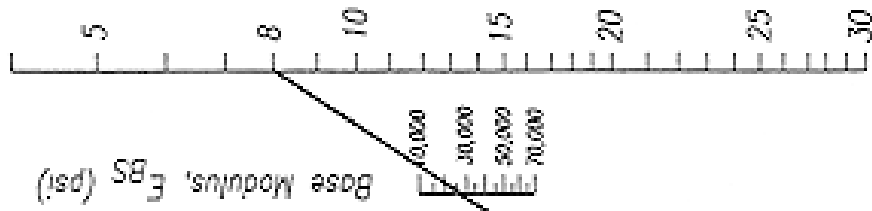
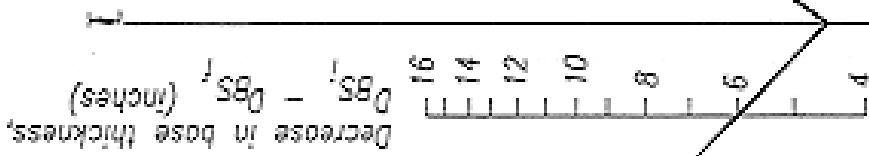
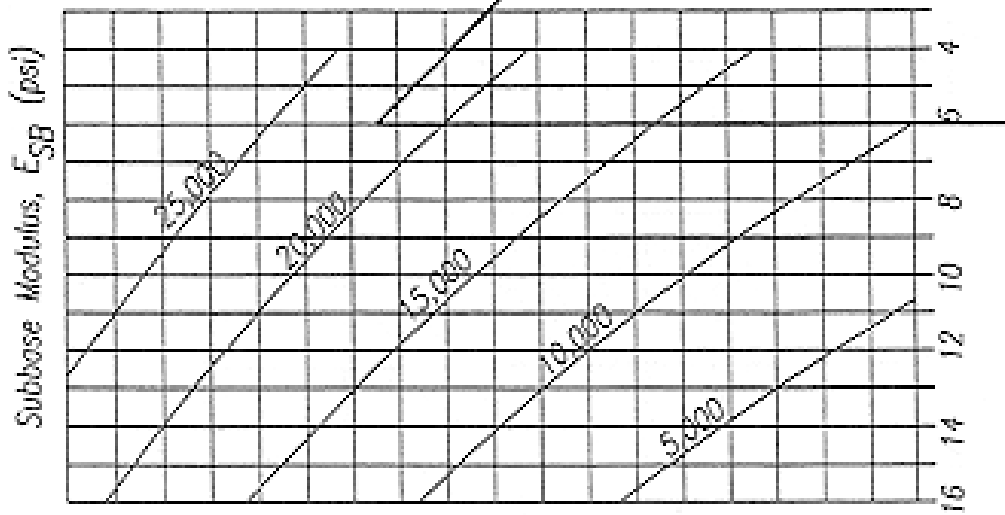

EXAMPLE:

$D_{BS} = 12.0$ INCHES

$D_{BS2} = 6.0$ INCHES

$E_{BS} = 30,000$ PSY

$E_{SB} = 21,000$ PSY

SOLUTION: $D_{SB} = 8.0$ INCHES

EQUIVALENT THICKNESS - SUBBASE VS BASE

PUEBLO COUNTY
PUBLIC WORKS

APPROVED: 4-23-98

REVISOR: _____
REVISOR: _____

FIGURE NO.

A3-4

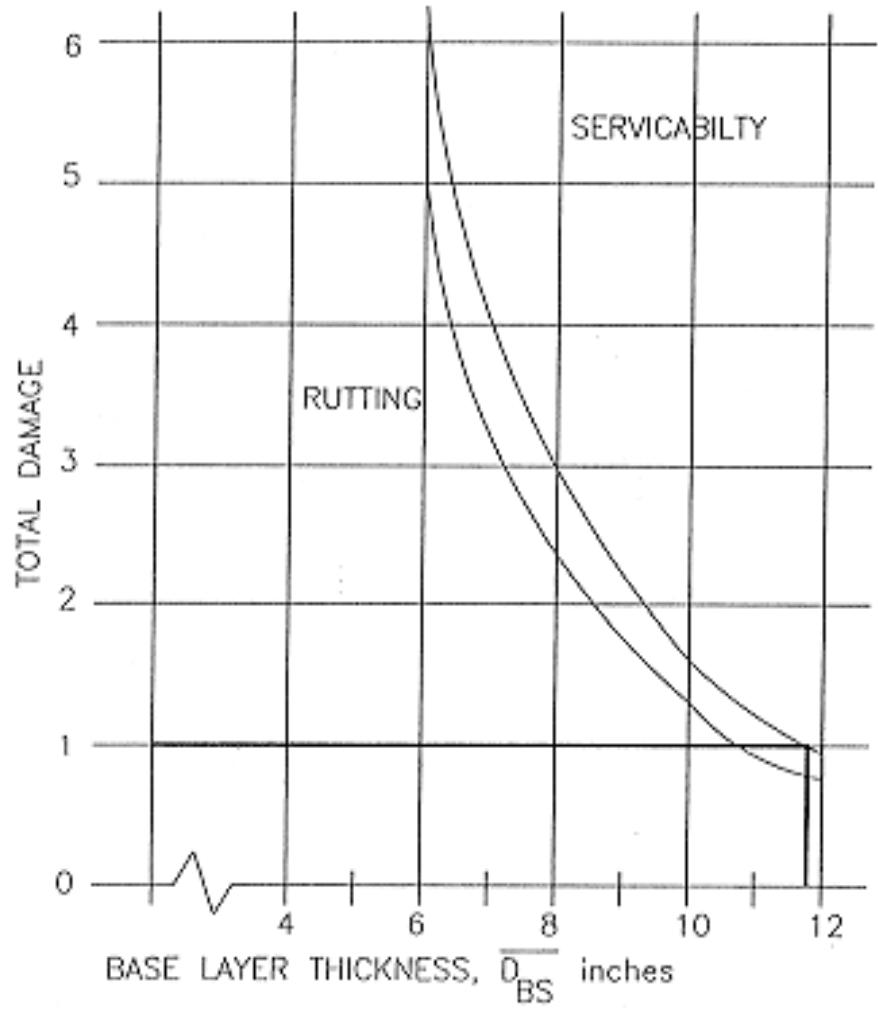

$$\overline{D}_{BS} = \overline{D}_{BS} + (0.5 \times GL) \quad GL=2$$

EXAMPLE: $\overline{D}_{BS} = 11.75$

$$\overline{D}_{BS} = 11.75 + (0.5 \times 2) = 12.75 \text{ inches}$$

TOTAL DAMAGE VS LAYER THICKNESS GRAPH

PUEBLO COUNTY
PUBLIC WORKS

APPROVED: A-23-98
REVISED: _____
REVISED: _____

FIGURE NO.
A3-5