

1 SCALE: 3/4"=1'-0"

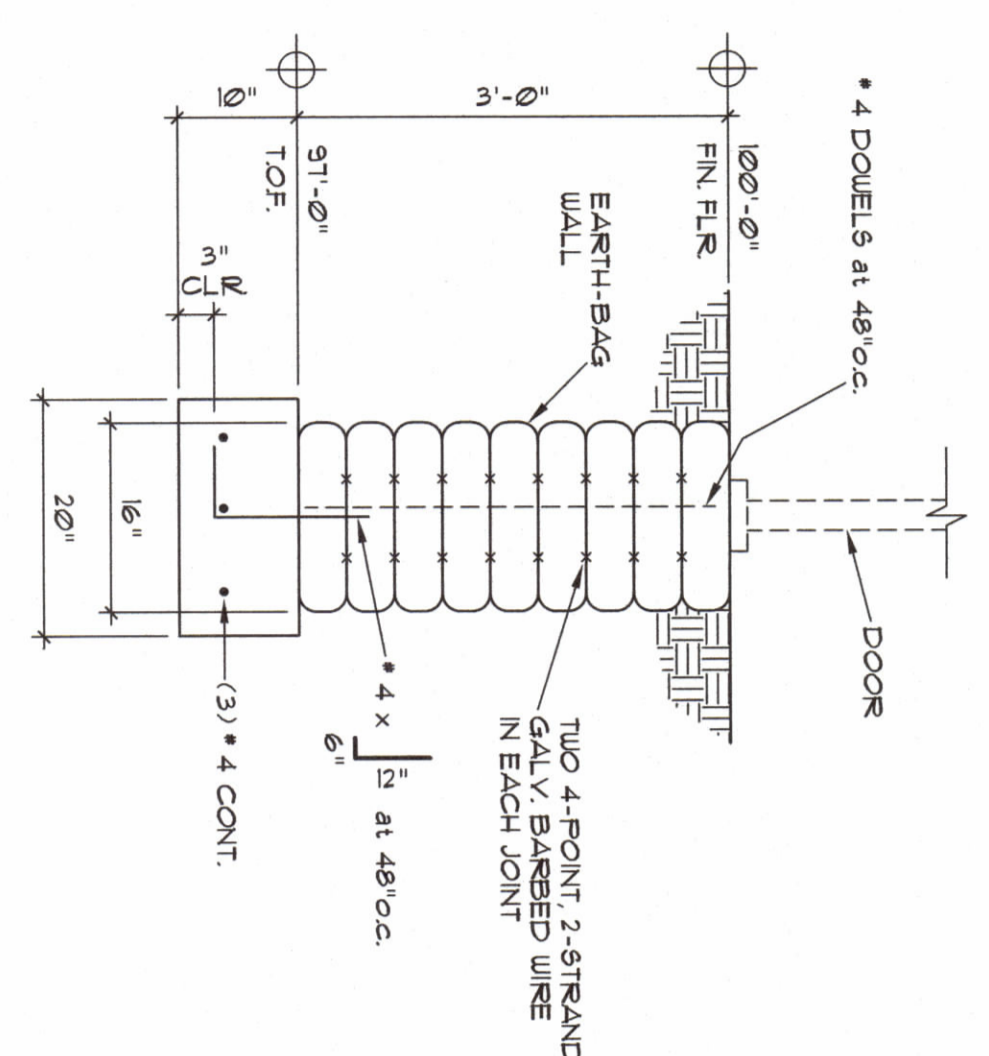

2 SCALE: 3/4"=1'-0"

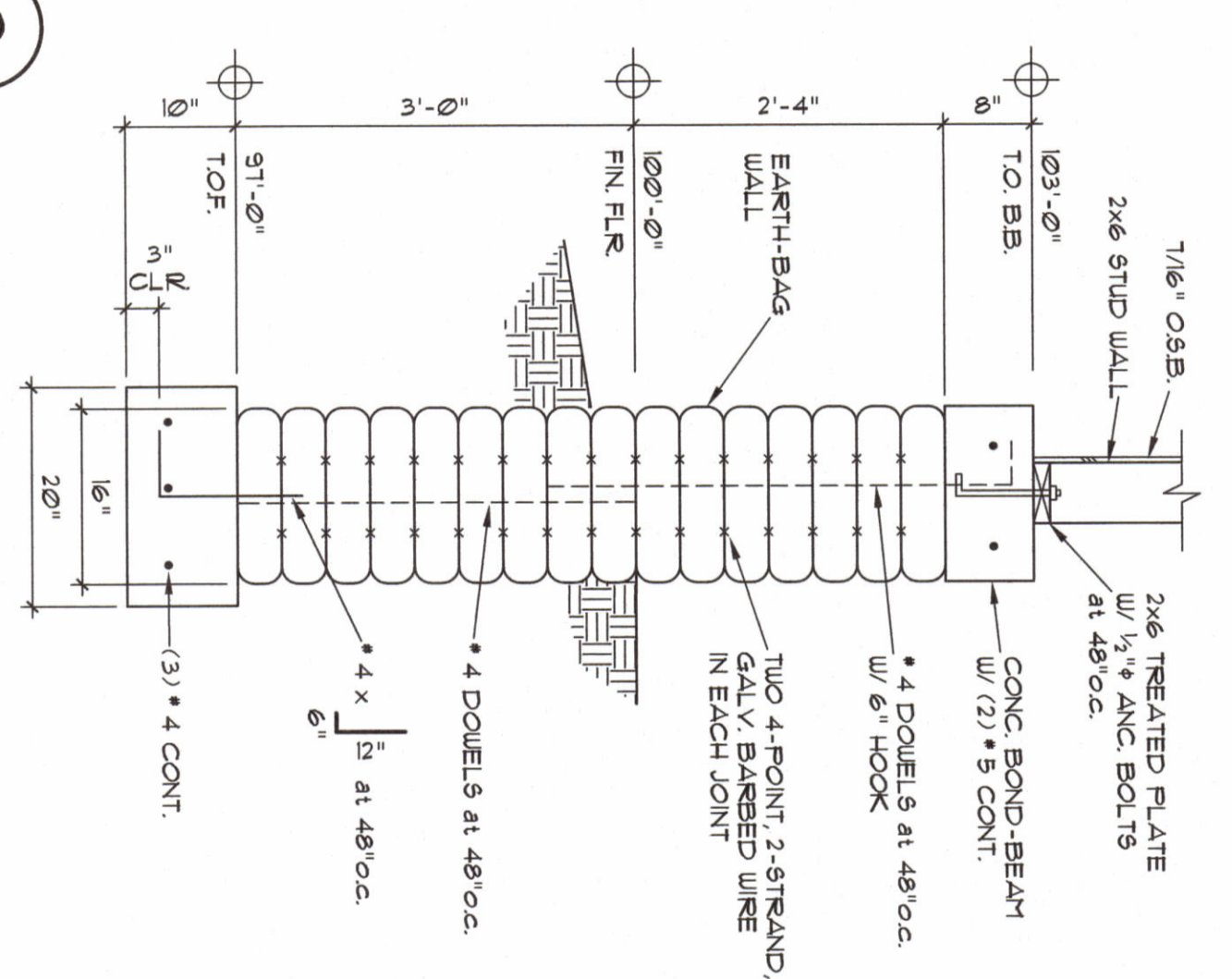

3 SCALE: 3/4"=1'-0"

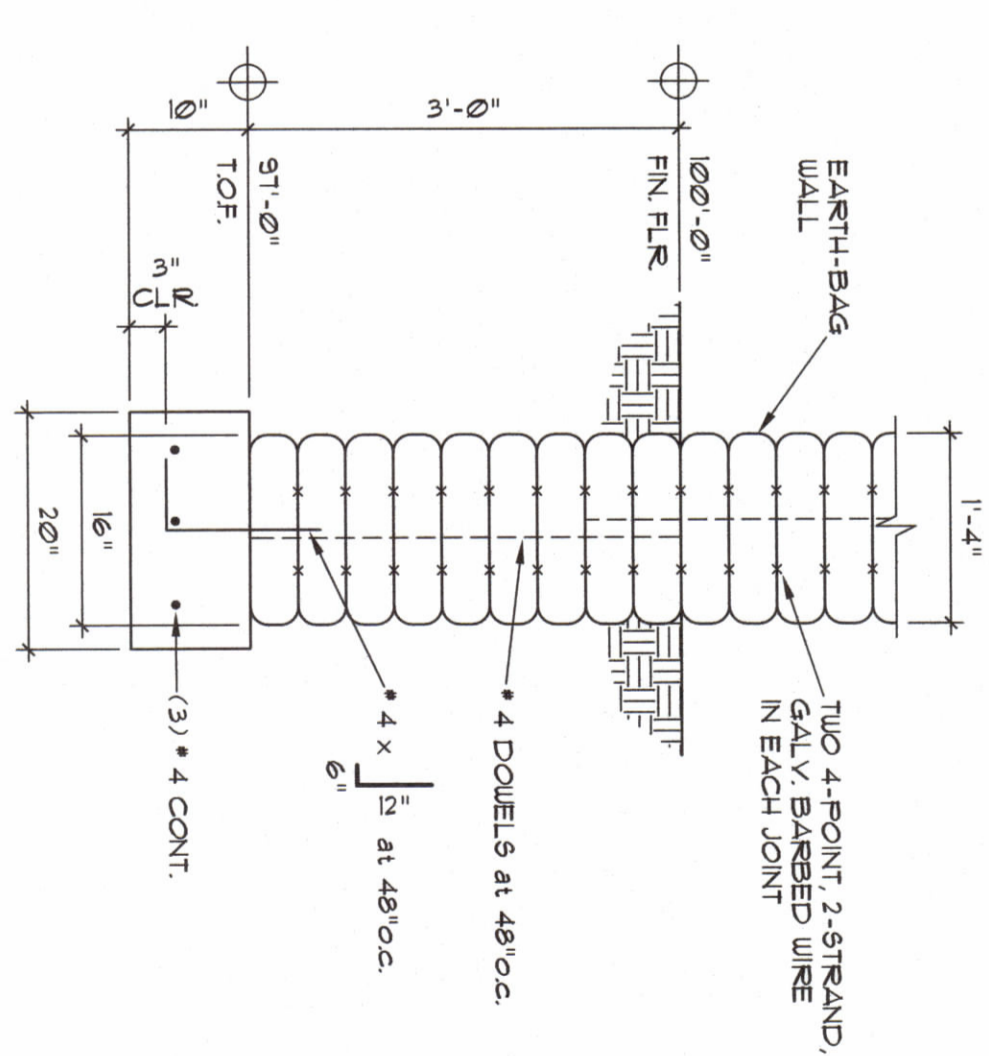

4 SCALE: 3/4"=1'-0"

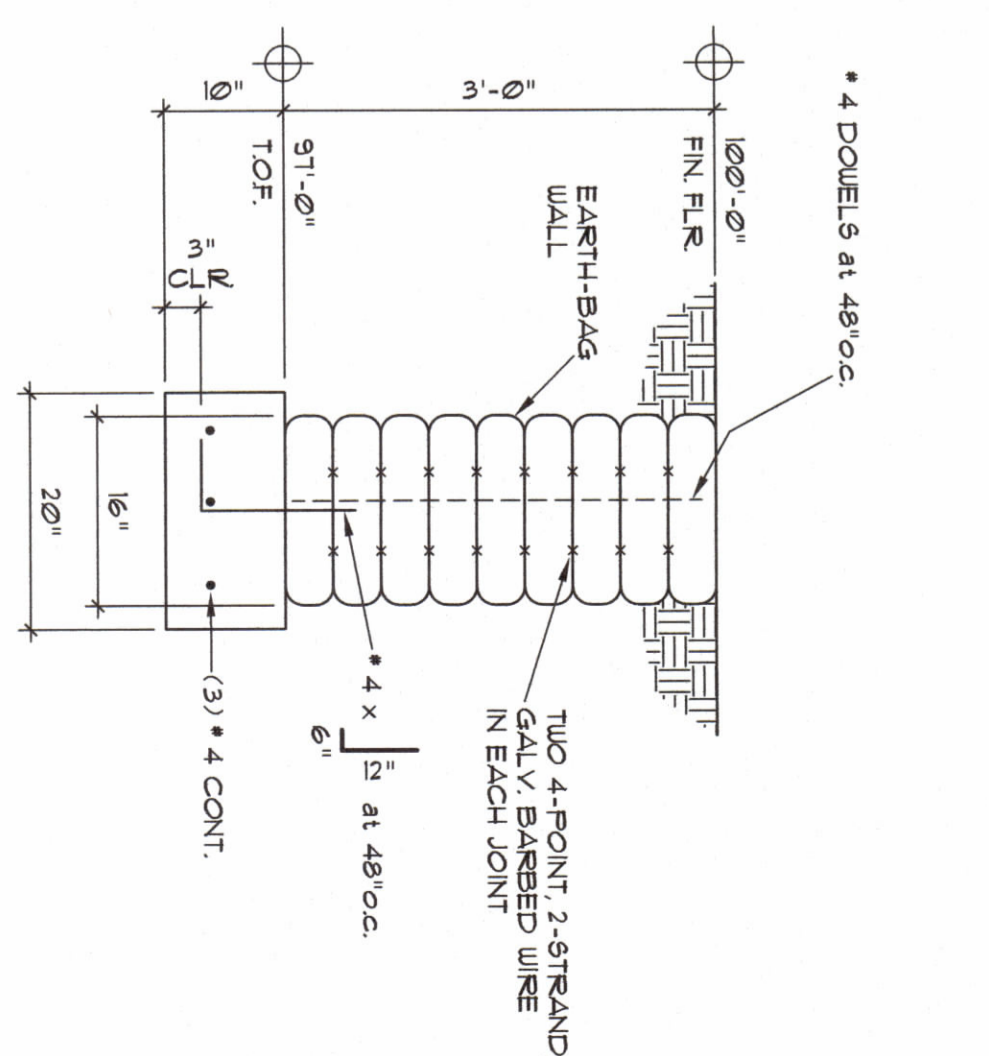

5 SCALE: 3/4"=1'-0"

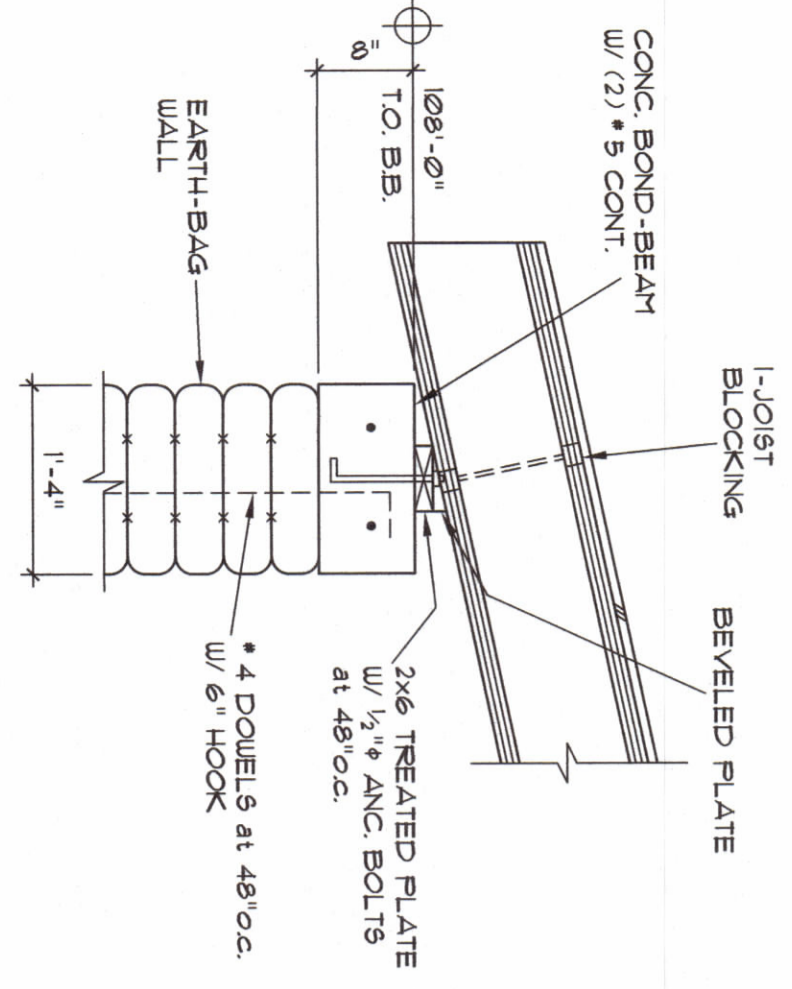

6 SCALE: 3/4"=1'-0"

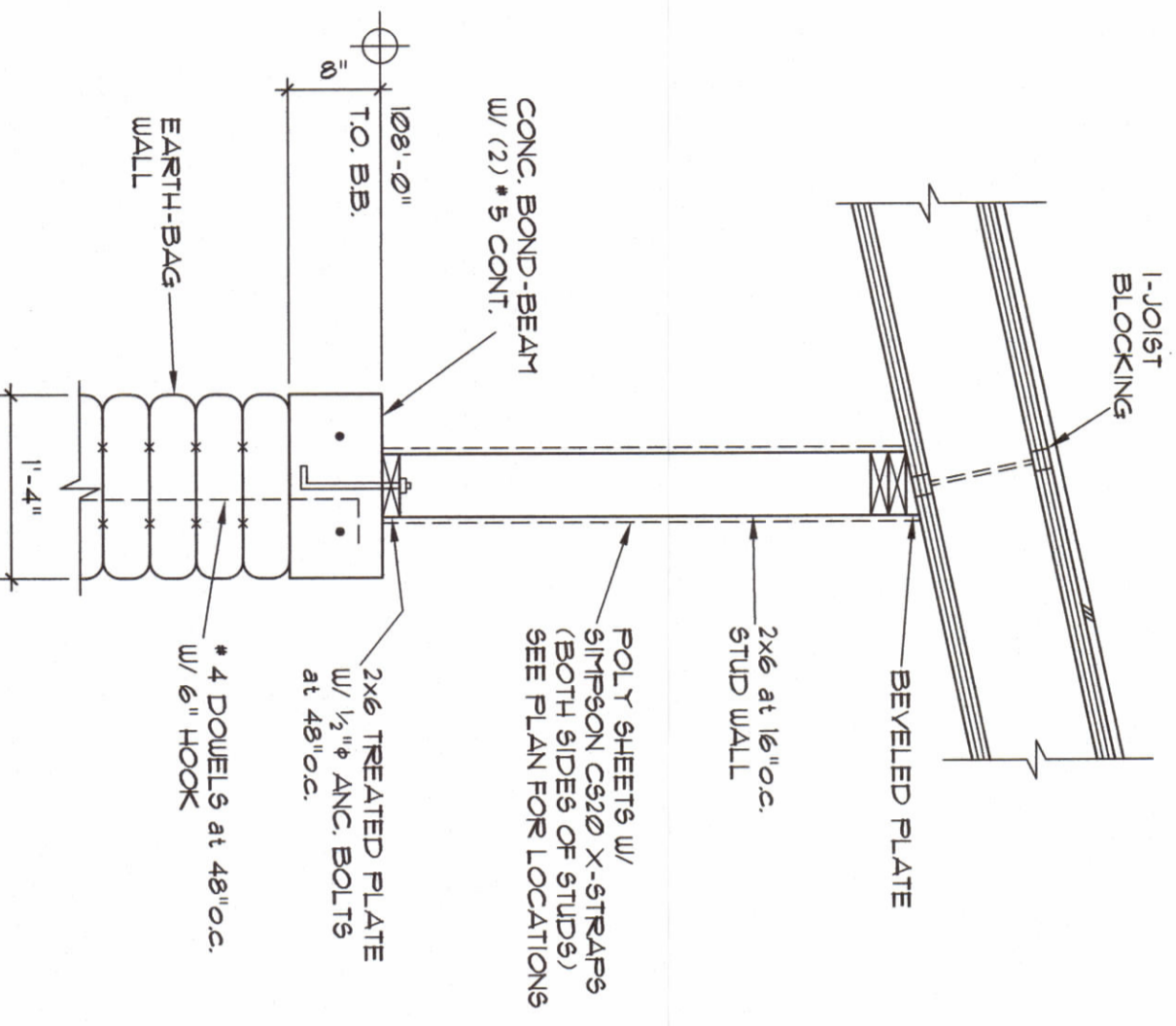

7 SCALE: 3/4"=1'-0"

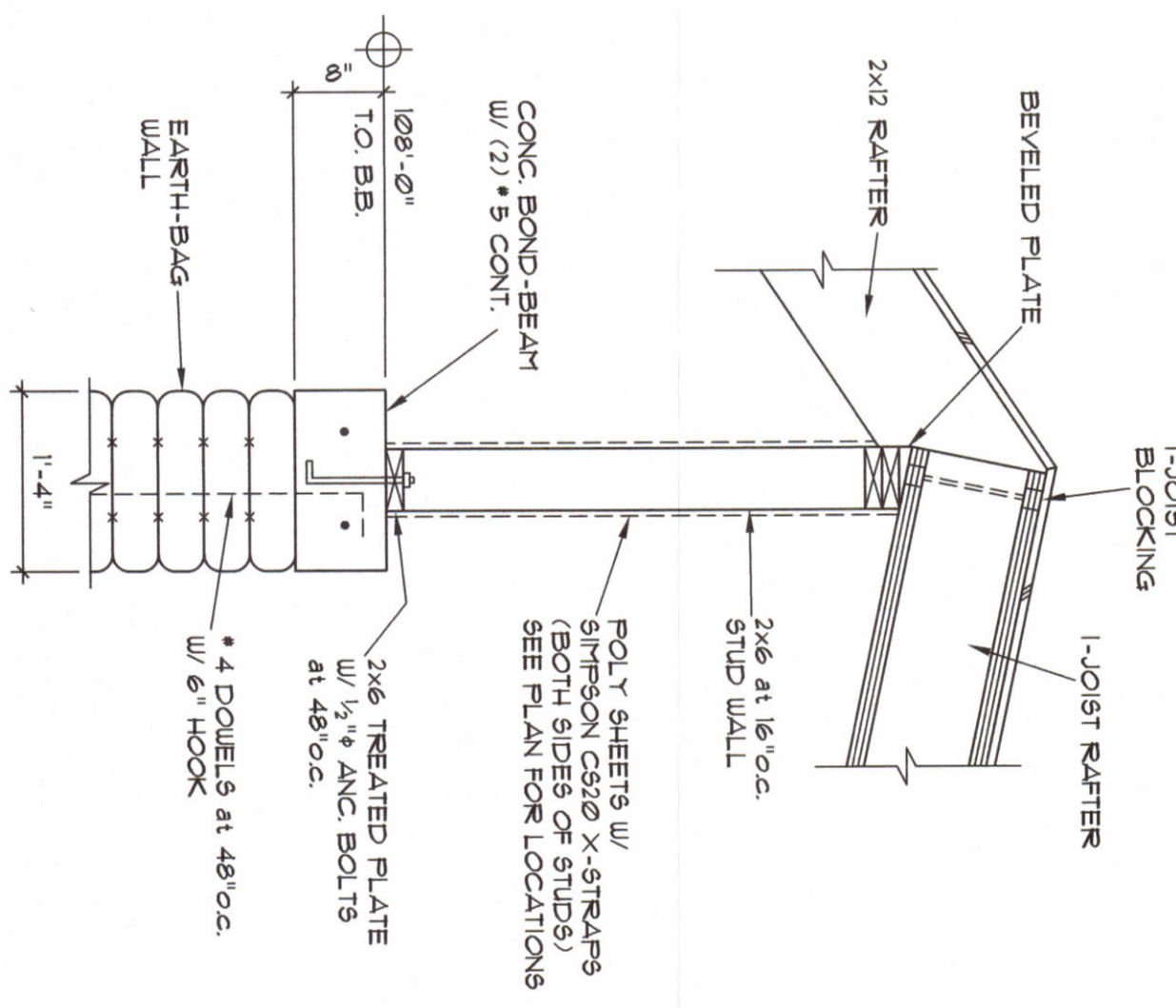

8 SCALE: 3/4"=1'-0"

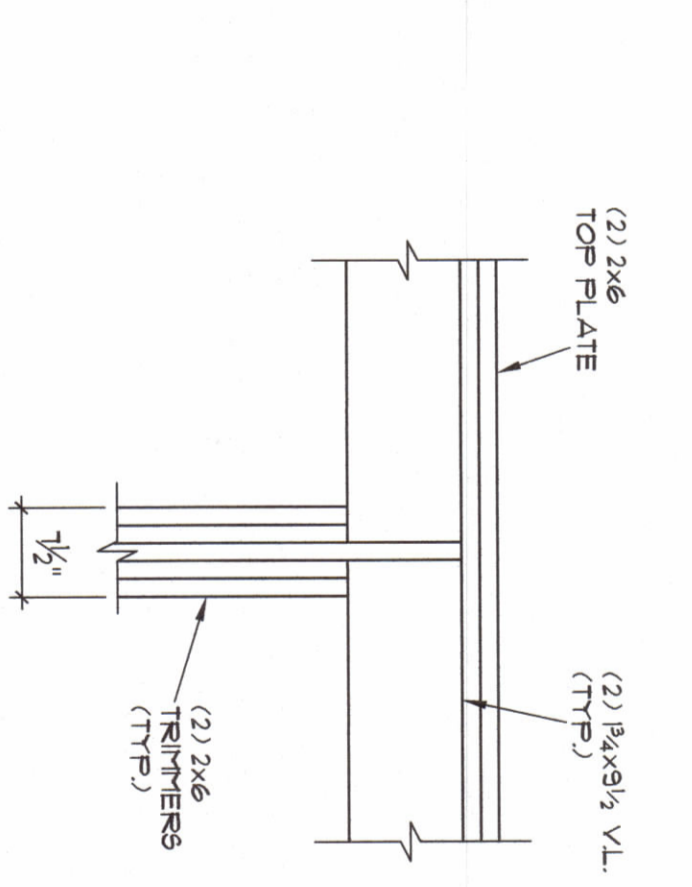

9 SCALE: 3/4"=1'-0"

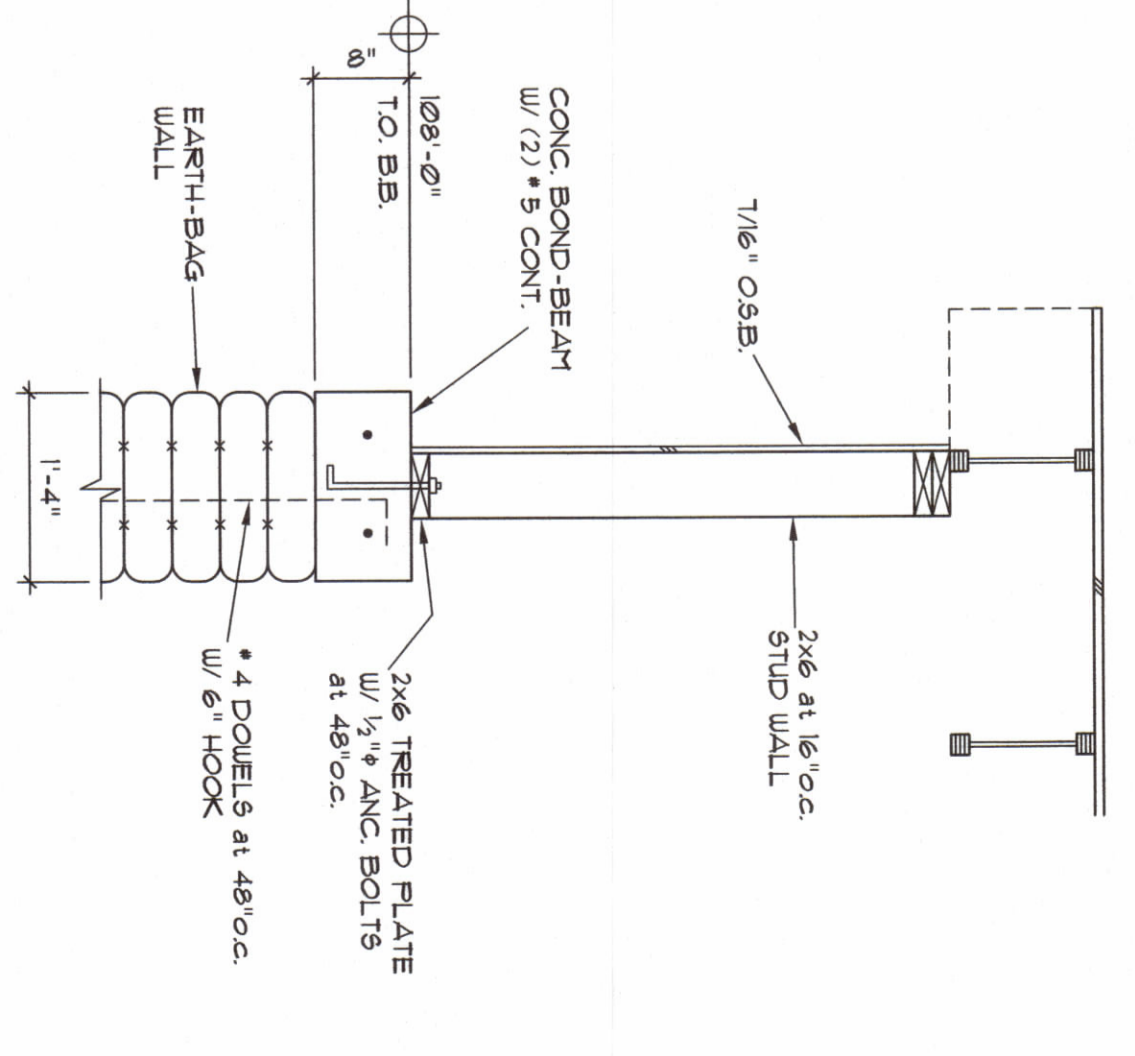

10 SCALE: 3/4"=1'-0"

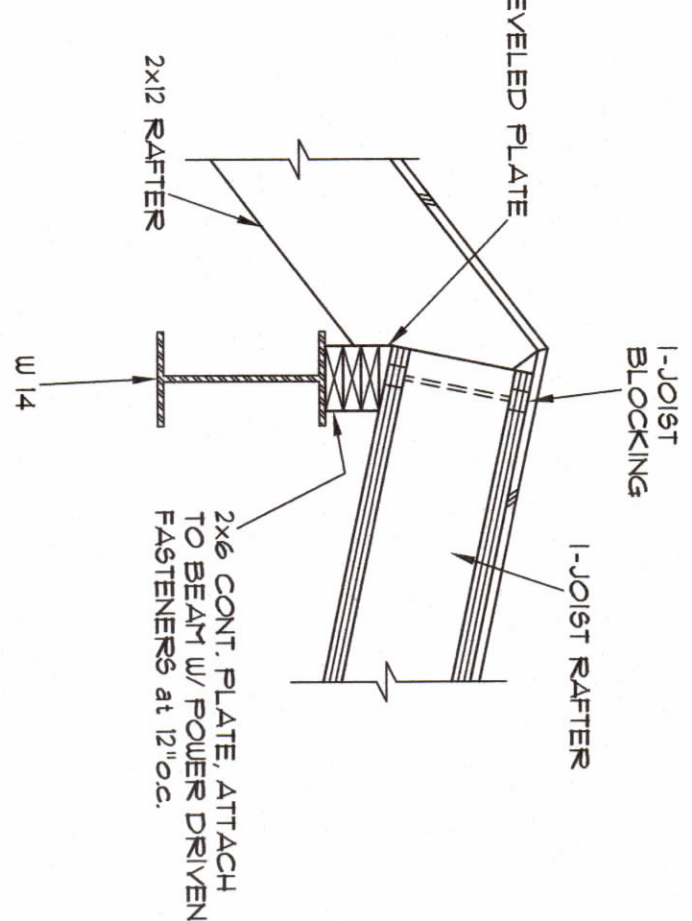

11 SCALE: 3/4"=1'-0"

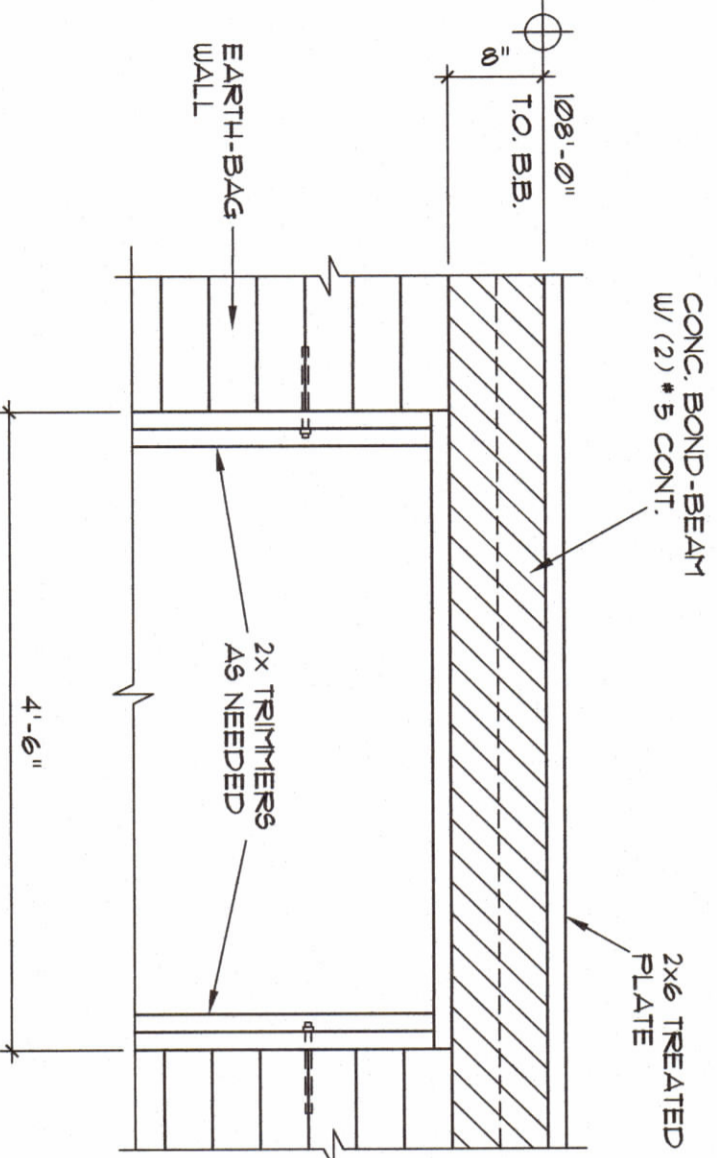

12 TYPICAL DOOR FRAMING SCALE: 3/4"=1'-0"

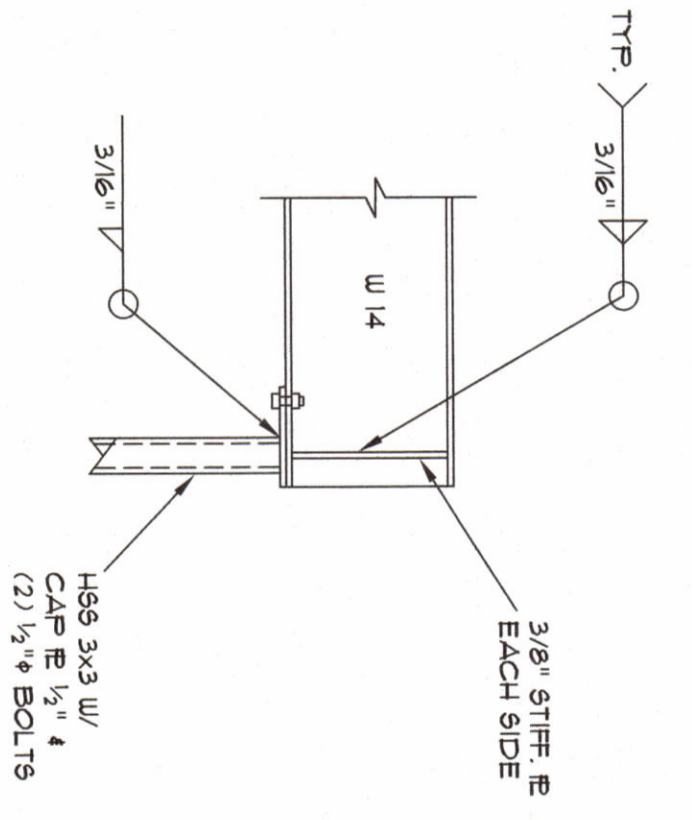

13 SCALE: 3/4"=1'-0"

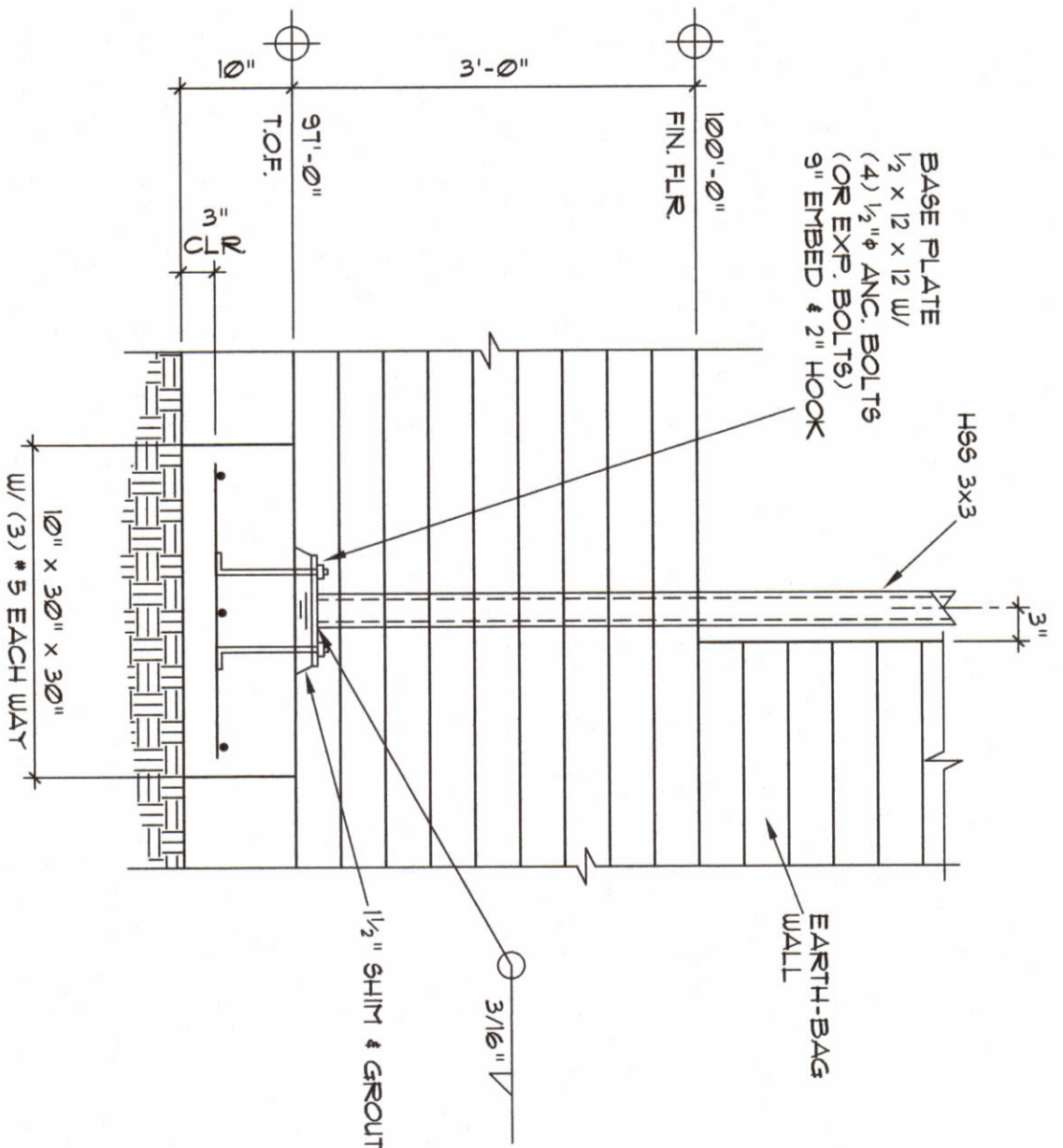

14 SCALE: 3/4"=1'-0"



RIEDEL RESIDENCE
 Lot 9
 Major Ranch, Phase # 2
 Huerfano County, Colorado

VALENTINE ENGINEERING, LLC
 1108 N. Main Street
 Pueblo, Colorado 81003 (719) 542-9230
 www.VALENTINEENGINEERING.com

Project	24.025
Date	April 5, 2024
Revision	
© 2024	

S3
 SCALE BAR 3/4"=1'-0"