

FOSS, SAN FILIPPO & MILNE, LLC

Counselors at Law

ROGER J. FOSS
GREGORY R. MILNE†
JANE R. PATIWELL
JOHN B. ANDERSON, III
NJ & NY BARS

†CERTIFIED BY THE SUPREME
COURT OF NEW JERSEY AS
CIVIL TRIAL ATTORNEY

BRITTANY P. TARABOUR
JOHN C. TASSINI

OF COUNSEL
MARTIN A. MCGANN, JR.

PHILIP E. SAN FILIPPO
(RETIRED)
JOHN W. CHRISTIE
(RETIRED)

December 6, 2022

Via Hand Delivery and email

Borough of Highlands
Land Use Board
42 Shore Drive
Highlands, NJ 07732
ATTN: NANCY TRAN, Land Use Secretary

Re: Sea Grass NJ, LLC
272 Bay Avenue, Block: 72, Lot: 12
And: Seadrift Avenue, Block: 73, Lot: 2
Highlands, New Jersey
Our File Number: 9344.00001

Dear Ms. Tran:

This office represents Sea Grass NJ, LLC in regard to the above referenced property and the Zoning Permit approval issued by you on November 3, 2022. Please be advised that the applicant, Sea Grass NJ, LLC, is seeking to change the use of the building located on 272 Bay Avenue (Block 72, Lot 12) and to obtain a conditional use permit to allow 272 Bay Avenue (Block 72, Lot 12) to be utilized as a conditionally permitted cannabis retailer under the Highlands Borough Ordinances Section 21-91 A. 3. D. and 21-97 M. This application will involve interior improvements to the building as well as cosmetic improvements to the exterior of the existing building. This application will also involve landscaping and other enhancements to an existing gravel parking lot located on Block 73, Lot 2, which will conform to the use as parking following the change of use. In that regard, enclosed please find the following:

1. Original and one (1) copy of the completed Land Use Board Application;
2. One (1) copy of the Zoning Permit Approval, dated November 3, 2022;
3. Original Narrative of Development;

December 6, 2022

Page - 2 -

Sea Grass

4. A copy of the Owner's Consent signed by Leonel Cervantes and dated November 2, 2022;
5. Proof that 4th quarter real estate taxes have been paid;
6. Resolution 22-217 in support of Cannabis Establishment;
7. Cannabis Regulatory Commission Approval of Conditional License Application;
8. One (1) original, sealed and signed Interior Renovations/Commercial Fit-Out architectural plan prepared by Shissias Design + Development, dated December 2, 2022;
9. One (1) original, sealed and signed Preliminary and Final Major Site Plan prepared by East Point Engineering, LLC, dated November 21, 2022;
10. Check no. 1005, in the sum of \$350.00 made payable to the Borough of Highlands, representing the application filing fees; and
11. Check no. 1006, in the amount of \$750.00 made payable to the Borough of Highlands, representing the escrow deposit required by the Borough.

Kindly acknowledge receipt of the above items on the copy of this letter enclosed, and return it to the person hand delivering this submission to you. Please advise us when this application has been deemed complete, and scheduled for a public hearing before the Land Use Board of the Borough of Highlands.

Thank you for your attention to this matter.

Very truly yours,
Foss, San Filippo & Milne, LLC

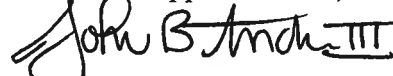

John B. Anderson, III, Esq.

For the Firm

janderson@fsfm-law.com

JBA:hs/Encs./Ltr to Borough trans application
cc: Client (via email, w/encls.)

Receipt of the above items is hereby acknowledged this _____ day of December, 2022.

Print Name: _____



Borough of Highlands
 42 Shore Drive
 Highlands, NJ 07732
 (732) 872-1224
 www.highlandsborough.org

LAND USE BOARD APPLICATION

FOR OFFICIAL USE

Date Rec'd: _____ Application #: _____ Fee: _____ Escrow: _____

1. APPLICANT

Name: Sea Grass NJ, LLC
 Address: c/o S. James Whelan, 135 Maple Ave.
 City: Red Bank State: NJ Zip: 07701
 Phone: 732-595-6700
 Email: idrwhelan@gmail.com
 Relation to property: Contract purchaser

2. OWNER

Name: Leonel Cervantes
 Address: _____
 City: Asbury Park State: NJ Zip: 07712
 Phone: _____
 Email: _____

3. TYPE OF APPLICATION (Check all that apply)

- | | |
|--|--|
| <input type="checkbox"/> Minor Subdivision | <input type="checkbox"/> Appeal – Zoning Denial date _____ |
| <input type="checkbox"/> Major Subdivision – Preliminary | <input type="checkbox"/> Appeal – Land Use Decision date _____ |
| <input type="checkbox"/> Major Subdivision – Final | <input type="checkbox"/> Informal Concept Plan Review |
| <input checked="" type="checkbox"/> Minor Site Plan | <input type="checkbox"/> Extension of Approval |
| <input type="checkbox"/> Major Site Plan – Preliminary | <input type="checkbox"/> Revision/Resubmission of Prior Application |
| <input type="checkbox"/> Major Site Plan – Final | <input checked="" type="checkbox"/> Other <u>Change of Use with Conditional Use Permit</u> |
| <input type="checkbox"/> Variance | |
| <input type="checkbox"/> Use Variance | |

4. PROPERTY INFORMATION

Block 72 Lot(s) 12 Address: 272 Bay Avenue (+ "Seadrift Avenue", Block 73, Lot 2)
 Lot size 2300 sq. feet # of Existing Lots 2 # of Proposed Lots 2
 Zone CBD Are there existing Deed Restrictions or Easements? No Yes – Please attach copies
 Has the property been subdivided? No Yes If yes, when? _____
 Attach copies of approved map or approved resolution
 Property taxes paid through 4th Quarter Sewer paid through 4th Quarter

5. ATTORNEY (A corporation, LLC, Limited Partnership, or S-Corp must be represented by a NJ attorney)

Name: Foss, San Filippo & Milne, LLC (John B. Anderson, III, Esq.)
 Address: 225 Broad Street, PO Box 896, Red Bank, NJ 07701
 Phone: 732-741-2525 Email: janderson@fsfm-law.com



Borough of Highlands
 42 Shore Drive
 Highlands, NJ 07732
 (732) 872-1224
 www.highlandsborough.org

6. APPLICANT'S OTHER PROFESSIONAL(S) – Engineer, Planner, Architect, etc.

Name: Shissias Design & Development
 Address: 27 1st Ave.
Rumson, NJ 07760
 Phone: 908-601-2647
 Email: kevin966@gmail.com

Name: East Point Engineering, LLC
 Address: 11 South Main Street
Marlboro, NJ 07746
 Phone: 732-577-0180
 Email: bpapi@eastpointeng.com

7. LAND USE

A. PROPERTY HISTORY –Describe in detail, nature of prior use(s) on the site, start date of such use, any prior Land Use Board applications for this site (attach copy of resolution, if applicable), history of current ownership, etc.

See attached Narrative of Development.

B. PROPOSED PLAN –Describe in detail, proposed use for property, including, but not limited to: 1) portion to be subdivided; 2) sell lot only; 3) construct house(s) for sale; 4) how trash will be disposed; 5) landscaping; 6) hours of operation; 7) type of goods/services; 8) fire lane. Attach additional sheets if necessary.

See attached Narrative of Development.

C. ADDITIONAL INFORMATION:

		Existing	Proposed
Residential:	How many dwelling units?	<u>1</u>	<u>0</u>
	How many bedrooms in each unit?	<u>2</u>	<u>0</u>
	How many on-site parking spaces?	<u>17 (on Block 73, Lot 2)</u>	<u>no change</u>
Commercial:	How many commercial uses on site?	<u>1</u>	<u>1</u>
	How many on-site parking spaces?	<u>17 (on Block 73, Lot 2)</u>	<u>no change</u>



8. VARIANCE REQUESTS Complete section(s) related to the relief being requested.

	Req'd	Exist.	Prop'd
Minimum Lot Requirements			
Lot Area	n/a	2300	no change
Frontage	n/a	23'	no change
Lot Depth	n/a	100'	no change
Minimum Yard Requirements			
Front Yard Setback	2'	1.78'	no change
2 nd Front Yard Setback	0'	1.3'	no change
Rear Yard Setback	12'	10.8'	no change
Side Yard Setback, right	0'	.61'	no change
Side Yard Setback, left	0'	1.3'	no change
Building Height	40'	<40'	no change

	Req'd	Exist.	Prop'd
Accessory Structures			
Fence/Wall Height	n/a	n/a	n/a
Garage/Shed Height	n/a	n/a	n/a
Garage/Shed Area	n/a	n/a	n/a
Pool Setback	n/a	n/a	n/a
Parking Requirements			
On-site Parking Spaces	4	17	17
Other (please add)			

9. OTHER RELIEF REQUESTED Please specify relief(s) and explain below.

See Narrative of Development.



Borough of Highlands
 42 Shore Drive
 Highlands, NJ 07732
 (732) 872-1224
 www.highlandsborough.org

10. NOTARIZED SIGNATURE OF APPLICANT

I certify that the foregoing statements and the materials submitted are true. I further certify that I am the individual Applicant, or that I am an Officer of the Applicant authorized to sign the application for the business organization. Additionally, I certify that the survey or plans submitted with this application shows and discloses the premises in its entirety, and I further certify that no buildings, fences, or other facilities have been constructed, installed, or otherwise located on the premises after the date of the survey with the exception of the structures shown.

SWORN & SUBSCRIBED to before me this
6th day of December 2022 (year)
John B. Anderson, III, Esq. (notary)
 (Seal)

[Signature] 12-6-22
 Signature Date
Stephen James Whelan, Member
 Print Full Name

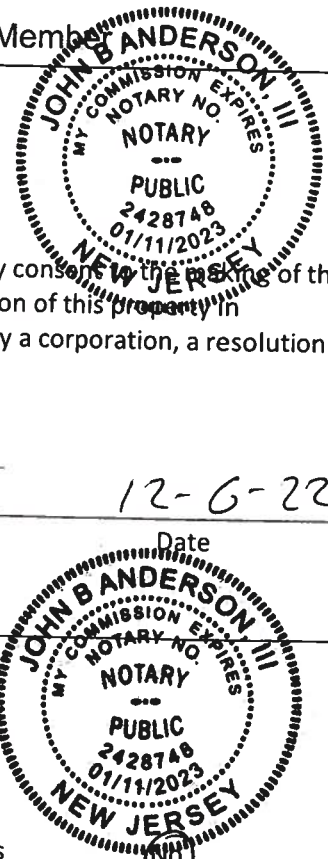

11. NOTARIZED CONSENT OF OWNER

I certify that I am the Owner of the property which is the subject of this application, hereby consent to the inspection of this property of this application and approval of the plans submitted herewith. I further consent to the inspection of this property in connection with this application as deemed necessary by the municipal agency (if owned by a corporation, a resolution must be attached authorizing the application and officer signature).

SWORN & SUBSCRIBED to before me this
6th day of December 2022 (year)
John B. Anderson, III, Esq. (notary)
 (Seal)

[Signature] 12-6-22
 Signature Date
Leonel Cervantes
 Print Full Name

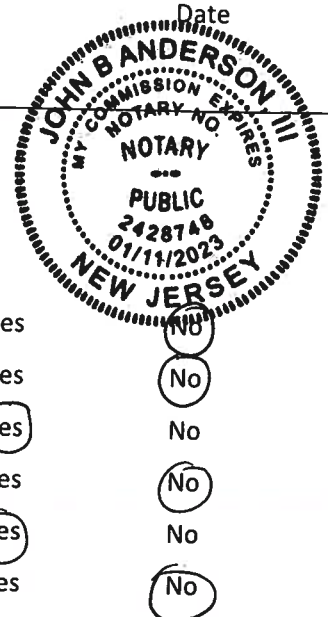

12A. DISCLOSURE STATEMENT Circle all that apply.

Pursuant to N.J.S.A. 40:55D-48.1 & 48.2, please answer the following questions:

- Is this application to subdivide a parcel of land into six (6) or more lots? Yes No
- Is this application to construct a multiple dwelling of 25 or more units? Yes No
- Is this an application for approval of a site(s) for non-residential purposes? Yes No
- Is this Applicant a corporation? Yes No
- Is the Applicant a limited liability corporation? Yes No
- Is the Applicant a partnership? Yes No

If you circled YES to any of the above, please complete the following Ownership Discloser Statement (use additional sheets if necessary).



Borough of Highlands
 42 Shore Drive
 Highlands, NJ 07732
 (732) 872-1224
 www.highlandsborough.org

12B. BUSINESS ORGANIZATION OWNERSHIP DISCLOSURE STATEMENT

Name of Corporation, Partnership, LLC, LLP, S-Corp:

Sea Grass NJ, LLC

Listed below are the names and addresses of all owners of 10% or more of the stock/interest* in the above referenced business organization:

NAME	ADDRESS
Stephen James Whelan	135 Maple Ave., Unit A, Red Bank, NJ 07701
Nicholas Frangipane, III	93 Black Point Rd., Rumson, NJ 07760

*If a corporation or a partnership owns 10% or more of the stock of a corporation, or 10% or great interest in a partnership, that corporation or partnership shall list the names and address of its stockholders holding 10% or more of its stock or 10% or greater interest in the partnership, and this requirement shall be followed until the names and addresses of the non-corporate stockholders and individual partners, exceeding the 10% ownership criterion established have been listed.

SWORN & SUBSCRIBED to before me this
6th day of December 2022 (year)
John B. Anderson, III, Esq. (notary)
 (Seal)

Stephen James Whelan 12-6-2022
 Signature (Officer/Partner) Date
Stephen James Whelan, Member
 Print Full Name Title

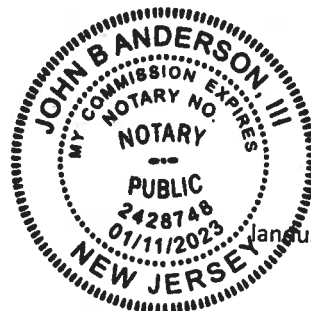

Owner: Leonel Cervantes
Applicant: Stephen James Whelan/Sea Grass NJ, LLC
272 Bay Avenue (Block 72, Lot 12) and "Sea Drift Avenue" (Block 73, Lot 2)
CBD Zone District (C-RO-1 Overlay)
Highlands, New Jersey

NARRATIVE OF DEVELOPMENT

Leonel Cervantes owns 272 Bay Avenue (Block 72, Lot 12) ("Property No. 1"). Property No. 1 is fully-developed with a two-story building (the "Building"). The first floor of the Building is a restaurant. The second floor of the Building is a residential apartment.

Leonel Cervantes also owns "Sea Drift Avenue" (Block 73, Lot 2) ("Property No. 2"). Property No. 2 is utilized as a parking lot in connection with the restaurant on Property No. 1.

Both properties are located within the CBD Zone District which conditionally permits cannabis retailers.

Stephen James Whelan/Sea Grass NJ, LLC (the "Applicant") is seeking to change the use of the Building located on Property No. 1 and to obtain a conditional use permit to allow Property No. 1 to be utilized as a conditionally permitted cannabis retailer under the Highlands Borough Ordinances Section 21-91 A. 3. D. and 21-97 M. This application will involve interior improvements to the Building as well as cosmetic improvements to the exterior of the existing Building. Applicant is **not** proposing to enlarge the existing Building or alter any setbacks or buffers.

The interior improvements the Building on Property No. 1 consist of:

- 1) Removal of the existing bar, two (2) existing bathrooms and an existing walk-in refrigerator;
- 2) Construction of a new retail sales floor accessible by means of a new ADA ramp and vestibule;
- 3) Construction of a new unisex bathroom;
- 4) Construction of a secure packing and receiving (backroom) area; and
- 5) Renovation of the existing second floor kitchen and bathroom for use with two (2) new offices on the second floor.

The exterior improvements to the Building on Property No. 1 consist of:

- 1) Installation of a barrier free ramp at the front entry on Bay Avenue;
- 2) Replacement of the existing awnings;
- 3) A new gated refuse area in place of the former walk-in refrigerator;
- 4) A fresh coat of paint; and
- 5) The installation of a new wall sign on the Bay Avenue frontage bearing the words "sea grass" and the company logo.

Property No. 1 meets the conditional use requirements for a cannabis retailer because: a) it is located in the CBD zone district; b) the proposed use will **not** contain any cannabis consumption area; and c) the property is located greater than 1,000 feet from any schools.

Applicant proposes to continue to utilize Property No. 2 as off-street parking in support of the cannabis retailer just as it is presently being used as off-street parking in connection with the existing restaurant on Property No. 1.

Property No. 2 will be improved through the removal of an existing shed and fenced in area. This will enable the lot to be striped for seventeen (17) parking spaces inclusive of one (1) ADA space nearest the corner of Bay Avenue and Sea Drift Avenue. The parking lot will also be improved through the installation of five (5) deciduous trees, twenty (20) shrubs, decorative grasses and perennial flowers. The existing parking sign will be re-faced at the same location. The existing Borough historic sign with placards for adjacent businesses will remain as well.

Applicant will comply with all prevailing hours of operation limitations for cannabis retailers. Applicant will obtain required licensure as a cannabis retailer and display the licensed at the premises.

The parking requirement in connection with the proposed use (first 1,000 square feet exempt and 1 space per 600 square feet thereafter) is less intense than required of the existing use (one per four seats or stools) and there is adequate parking on Property No. 2 to avoid any parking variance. More specifically, Property No. 2 contains seventeen (17) parking spaces where the use only requires four (4) or less parking spaces.



Borough of Highlands
 42 Shore Drive, Highlands, NJ 07732
 Phone: (82) 872-1224
 www.highlandsborough.org

Zoning Permit Application

Note: All applications must be submitted with a property survey showing the sizes of the structure(s) and their location. Applications involving businesses must show the scope of the business and include all activities that will be a part of the business.

The following NON-REFUNDABLE fees shall apply: Residential Single & Two-Family \$25 Check # Cash
 Commercial/Other residential \$50 Check # Cash

APPLICANT Name: S. James Whelan / Sea Grass NJ, LLC Date: 11/3/2022
 Address: 135 Maple Ave. Red Bank, NJ 07701
 Phone# 732-595-6700 Email: JDR Whelan@gmail.com

Block: 72 Lot(s): 12 Zone: CBD (+ Block 73, Lot 2)
 Street Address: 272 Bay Ave. (+ Sea Drift Avenue)

See attached

Check one: New* Addition* Alteration Repair Other

I certify the attached survey is accurate relating to existing and proposed improvements. In addition, I grant permission to the Borough of Highlands and their Agents to come onto the subject property, for the purposes of conducting inspections, relating to the application.

YES NO

Signature: [Signature] Date: 11/3/2022

Check applicable Flood Zone: AE VE X

All applications within the AE and VE Flood Zones, as indicated upon the most recent FEMA Flood Maps, require submission of a determination from the NJDEP.

Determination: Approved Denied Zoning Officer: [Signature]
 If your application has been DENIED, it is due to the following: Date: 11-3-22
Ordinance Section Allowed/Required Proposed

Remarks: _____

Note: A Zoning Permit indicates that the proposed project conforms to the planning/zoning regulations of the Borough of Highlands. A building permit is required (per the requirements of the Uniform Construction Code of NJ) BEFORE beginning work. The Zoning Permit is valid for one year. If your application has been denied, you may appeal this denial to the Land Use Board as provided by the New Jersey Municipal Land Use Law. You must submit letter of appeal to the Land Use Board Secretary within 20 days.

* Note: Applications for New and Addition require a Flood Plain Review Application to the Borough Flood Administrator upon submission of this application.

Owner: Leonel Cervantes
Applicant: Stephen James Whelan/Sea Grass NJ, LLC
272 Bay Avenue (Block 72, Lot 12) and “Sea Drift Avenue” (Block 73, Lot 2)
CBD Zone District (C-RO-1 Overlay)
Highlands, New Jersey

NARRATIVE OF DEVELOPMENT

Leonel Cervantes owns 272 Bay Avenue (Block 72, Lot 12) (“Property No. 1”). Property No. 1 is fully-developed with a two-story building (the “Building”). The first floor of the Building is a restaurant. The second floor of the Building is a residential apartment.

Leonel Cervantes also owns “Sea Drift Avenue” (Block 73, Lot 2) (“Property No. 2”). Property No. 2 is utilized as a parking lot in connection with the restaurant on Property No. 1.

Both properties are located within the CBD Zone District which conditionally permits cannabis retailers.

Stephen James Whelan/Sea Grass NJ, LLC (the “Applicant”) is seeking to change the use of the Building located on Property No. 1 and to obtain a conditional use permit to allow Property No. 1 to be utilized as a conditionally permitted cannabis retailer under the Highlands Borough Ordinances Section 21-91 A. 3. D. and 21-97 M. This application will involve interior improvements to the Building as well as cosmetic improvements to the exterior of the existing Building. Applicant is **not** proposing to enlarge the existing Building or alter any setbacks or buffers.

The interior improvements the Building on Property No. 1 consist of:

- 1) Removal of the existing bar, two (2) existing bathrooms and an existing walk-in refrigerator;
- 2) Construction of a new retail sales floor accessible by means of a new ADA ramp and vestibule;
- 3) Construction of a new unisex bathroom;
- 4) Construction of a secure packing and receiving (backroom) area; and
- 5) Renovation of the existing second floor kitchen and bathroom for use with two (2) new offices on the second floor.

The exterior improvements to the Building on Property No. 1 consist of:

- 1) Installation of a barrier free ramp at the front entry on Bay Avenue;
- 2) Replacement of the existing awnings;
- 3) A new gated refuse area in place of the former walk-in refrigerator;
- 4) A fresh coat of paint; and
- 5) The installation of a new wall sign on the Bay Avenue frontage bearing the words “sea grass” and the company logo.

Property No. 1 meets the conditional use requirements for a cannabis retailer because: a) it is located in the CBD zone district; b) the proposed use will **not** contain any cannabis consumption area; and c) the property is located greater than 1,000 feet from any schools.

Applicant proposes to continue to utilize Property No. 2 as off-street parking in support of the cannabis retailer just as it is presently being used as off-street parking in connection with the existing restaurant on Property No. 1.

Property No. 2 will be improved through the removal of an existing shed and fenced in area. This will enable the lot to be striped for seventeen (17) parking spaces inclusive of one (1) ADA space nearest the corner of Bay Avenue and Sea Drift Avenue. The parking lot will also be improved through the installation of five (5) deciduous trees, twenty (20) shrubs, decorative grasses and perennial flowers. The existing parking sign will be re-faced at the same location. The existing Borough historic sign with placards for adjacent businesses will remain as well.

Applicant will comply with all prevailing hours of operation limitations for cannabis retailers. Applicant will obtain required licensure as a cannabis retailer and display the licensed at the premises.

The parking requirement in connection with the proposed use (first 1,000 square feet exempt and 1 space per 600 square feet thereafter) is less intense than required of the existing use (one per four seats or stools) and there is adequate parking on Property No. 2 to avoid any parking variance. More specifically, Property No. 2 contains seventeen (17) parking spaces where the use only requires four (4) or less parking spaces.

FOSS SAN FILIPPO & MILNE, LLC
225 Broad Street
P.O. Box 896
Red Bank, New Jersey 07701-0896
(732)-741-2525- Phone
(732)-741-2192- Fax
janderson@fsfm-law.com
Attorneys for Applicant, Stephen James Whelan/Sea Grass NJ, LLC

IN THE MATTER OF THE APPLICATION

Leonel Cervantes/Highlands
272 Bay Avenue (and 270 Bay Avenue)
Block 72, Lot 12 (and Block 73, Lot 2)
Highlands, New Jersey 07732

OWNER'S CONSENT

STATE OF NEW JERSEY :
 : SS
COUNTY OF Monmouth :

I, Leonel Cervantes, of full age, do hereby certify:

1. I am the owner of real property, located at 272 Bay Avenue, Highlands, New Jersey, and shown as Block 72, Lot 12, on the municipal Tax Map of the Borough of Highlands. I am also the owner of real property, located at 270 Bay Avenue, Highlands, New Jersey, and shown as Block 73, Lot 2, on the municipal Tax Map of the Borough of Highlands. As such, I have full knowledge of the facts contained in this Owner's Consent.

2. As the owner of aforesaid properties, I hereby authorize Stephen James Whelan/Sea Grass NJ, LLC to file one or more applications and/or appeals to the Land Use Board of the Borough of Highlands and also to file any necessary County and State agencies applications (as applicable) for the proposed development of these properties.

3. As the owner of aforesaid properties, I hereby authorize the applicant, their duly authorized representatives, agents and all professionals or experts retained by it to advance the development application and any and all Federal, State, County or Municipal Officials to enter upon the land in order to inspect the same in furtherance of the development application of Stephen James Whelan/Sea Grass NJ, LLC. These persons include, but are not limited to, members of the Land Use Board (as applicable), engineers, health inspectors, Fire and Police Departments, Planners, Zoning Officers, County, State and Federal Officials, and their duly authorized representatives. Authorization is hereby granted to the Borough of Highlands, its agents, employees and representatives to inspect, all or any part of the above properties, whether interior or exterior, at any reasonable hour of the day with respect to any matters relating to the development application, within the judgment of the Borough of Highlands, or such representatives, related thereto. This Authorization shall permit representatives to take photographs, and to make sketches and notes with respect to the subject properties.

4. As the owner of aforesaid properties, I hereby authorize the applicant to attach a "certified to be true copy" of this Owner's Consent to any and all development applications which it is required to file as part of any federal, state, county or municipal permit applications.

5. Throughout this document and unless the context otherwise requires, the singular number shall include the plural, and vice versa.

I certify that the foregoing is true and correct to the best of my knowledge and belief; I are aware that if any of the foregoing is willfully false, I am subject to punishment.

DocuSigned by:

17F7079682694CF
LEONEL CERVANTES

Dated: 11/2/2022, 2022

CURRENT

BLOCK

72

DATE

12/6/22

LOT

12

72 Bay Ave

~~300.55~~
DEC 6 2022
BY

0434

BOROUGH OF HIGHLANDS - TAX OFFICE

171 BAY AVENUE HIGHLANDS, N.J.

BLOCK 73

CURRENT

DATE 12/6/22

LOT 2

Seadrift Ave

~~DATA~~
DEC 6 2022
BY SEC. 20

0431



BOROUGH OF HIGHLANDS
COUNTY OF MONMOUTH

RESOLUTION 22-217

IN SUPPORT OF CANNABIS ESTABLISHMENT

WHEREAS, on January 18, 2010, Governor Jon Corzine signed the New Jersey Compassionate Use Medical Marijuana Act, N.J.S.A. 24:61-1 et seq., which provided for the legalization of medical marijuana and creation of a program to allow persons suffering from qualifying debilitating medical conditions to obtain medical marijuana in a safe, timely and compassionate manner; and

WHEREAS, the State of New Jersey in 2018 amended its regulatory scheme so as to expand the scope of citizens to whom medical marijuana may be prescribed and so as to make medical marijuana more accessible and available to many of the citizens who need it; and

WHEREAS, on November 3, 2020, the Marijuana Legalization Amendment was approved by voters in New Jersey, which legalized the possession and use of cannabis for residents twenty-one years of age or older;

WHEREAS, on February 22, 2021, Governor Phil Murphy signed into law the New Jersey Cannabis Regulatory, Enforcement Assistance, and Marketplace Act, which established the adult use cannabis program in the State of New Jersey.

WHEREAS, the Borough of Highlands endorses the adult use cannabis program in the State of New Jersey, as well as the medical use program, which provides needed relief to the many persons suffering from chronic and/or debilitating illnesses who may benefit from this program; and

WHEREAS, the Borough of Highlands supports the safe and appropriate siting of an adult-use cannabis dispensary within the Central Business District zone(s) of the Borough of Highlands to the extent consistent with applicable state and local statutes, rules, regulations, and ordinances, including but not limited to the cannabis retailer licensing provisions of Borough Code Section 4-18 and the conditional use zoning requirements of Section 21-97(M); and

WHEREAS, Sea Grass NJ LLC has expressed interest in the siting of such a facility within the Borough of Highlands.

NOW, THEREFORE, BE IT RESOLVED, that the Borough Council supports the safe and appropriate siting of an adult-use cannabis dispensary within the Central Business District zone(s) of the Borough of Sea Grass NJ LLC to the extent consistent with applicable state and local statutes, rules, regulations and ordinances, including but not limited to the cannabis retailer licensing provisions of Borough Code Section 4-18 and the conditional use zoning requirements of Section 21-97(M).

BE IT FURTHER RESOLVED, that due to the Borough's limit of a single Cannabis Retailer License, upon submission of a complete license application, the license applicant that receives Cannabis Regulatory Commission approval first in time shall be deemed approved by the Borough.

Motion to Approve R 22-217:

	INTRODUCED	SECOND	AYE	NAY	RECUSE	ABSENT
CERVANTES			X			
CHELAK			X			
MELNYK				X		
OLSZEWSKI		X	X			
BROULLON	X		X			

This is a Certified True copy of the Original Resolution on file in the Municipal Clerk's Office.

DATE OF VOTE: October 5, 2022



 Nancy Tran, Municipal Clerk
 Borough of Highlands



State of New Jersey
CANNABIS REGULATORY COMMISSION

P.O. BOX 216
TRENTON, N.J. 08625-0216

PHILLIP D. MURPHY
Governor

SHEILA Y. OLIVER
Lt. Governor

DIANNA HOUEYOU, *Chair*
SAMUEL DELGADO, *Vice Chair*
KRISTA NASH, *Commissioner*
MARIA DEL CID-KOSSO, *Commissioner*
CHARLES BARKER, *Commissioner*
JEFF BROWN, *Executive Director*

July 29, 2022

Sea Grass NJ
Nicholas Frangipane
nick.frang@gmail.com
135 Maple Ave.
Red Bank, NJ 07701

Re: **FINAL AGENCY DECISION**
APPROVAL OF CONDITIONAL LICENSE APPLICATION

Dear Nicholas Frangipane:

Congratulations! The New Jersey Cannabis Regulatory Commission ("NJ-CRC") has received and reviewed your application for a Class 5 Cannabis Retailer to operate an adult personal-use cannabis business in the state of New Jersey. Upon the completion of the NJ-CRC's review, your application for a conditional license has been approved.

Pursuant to N.J.A.C. 17:30-7.2(f), the NJ-CRC shall approve a conditional license application where the applicant (1) has submitted a complete conditional license application in accordance with N.J.A.C. 17:30-7.3 and the notice of application acceptance pursuant to N.J.A.C. 17:30-6.1; (2) has scored sufficiently high to be issued a conditional license in accordance with the criteria included in the notice of application acceptance pursuant to N.J.A.C. 17:30-6.1 and 7.3; (3) is qualified to hold a conditional license pursuant to N.J.A.C. 17:30-7.4; and (4) has submitted application fees pursuant to N.J.A.C. 17:30-7.17. The above-referenced entity has satisfied all criteria.

Following this written notice of approval, the license applicant must notify the NJ-CRC within five (5) business days whether it will accept the license, or if it will abandon the license. Acceptance or abandonment of the license can be supplied by a letter from the applicant's listed primary contact, submitted electronically to crc.licensing@crc.nj.gov. **Pursuant to N.J.A.C. 17:30-7.5(c), failure of the applicant to notify the NJ-CRC of its decision to accept or abandon the license by the specified deadline shall result in the license being deemed abandoned.**

Should you choose to accept this license, the NJ-CRC will continue to verify information contained in your application and notify you when to submit the required conditional license application approval fee established at N.J.A.C. 17:30-7.17. Following receipt of the conditional license application approval fee,

the NJ-CRC will issue the conditional license and provide the same to the applicant.

Acceptance of the license, submission of the conditional license application approval fee, and issuance of the conditional license by the NJ-CRC to the applicant triggers the beginning of the conditional license phase as established at N.J.A.C. 17:30-7.6. During the conditional license phase, the conditional license holder must (1) establish control of the proposed site; (2) gain municipal approval; and (3) develop and submit a conditional license conversion application. The conditional license phase commences on the date the conditional license is issued to the license applicant and expires after 120 calendar days. Pursuant to N.J.S.A. 24:6I-36b.(2)(d)(i) the NJ-CRC may extend the conditional license phase of any applicant for an additional 45 calendar days at its discretion. **To create better efficiency and to support new applicants, the NJ-CRC will automatically extend the conditional license phase for the above-listed applicant for an additional 45 calendar days.** The applicant may satisfy the conditional license phase and begin the process to convert to an annual license at any time prior to the end date for the conditional license phase. The additional 45 calendar days are offered as a courtesy and to prevent the necessity of the applicant submitting a formal request for extension.

During the conditional license phase, the conditional license holder shall not engage in purchasing, possessing, selling, cultivating, manufacturing, or selling cannabis or cannabis products. N.J.A.C. 17:30-7.6(e). Failure to adhere to this restriction may subject the applicant to adverse action by the Commission and may expose the applicant to law enforcement action.

The following activities are permitted during the conditional license phase:

1. The conditional license holder may obtain additional funding by adding new loans or gifts from new or existing financial sources not listed in the conditional license application. Conditional license applicants are reminded, however, that during the conversion phase, the NJ-CRC may investigate and may conduct probity review of the license applicant, its owners, principals, and related entities and their finances, ownership, and control structure (See N.J.A.C. 17:30-7.7(e)), and conditional license holders are therefore advised to not execute any additional financing agreements that have not been received and reviewed by the NJ-CRC;
2. The conditional license holder may change the proposed location of the cannabis business, and such new location shall be reflected in the conditional license conversion application;
3. The conditional license holder may notify the NJ-CRC of its intention to abandon the license, which will then be returned to the Commission; and
4. The majority share of the ownership interest in the license holder shall remain the same as at the time of license issuance, however:
 - a. An owner or passive investor of the conditional license holder may transfer ownership interest to another qualified party; and
 - b. The conditional license holder may add new qualified owners and principals.

Certain businesses are subject to the following additional restrictions:

1. A Diversely-Owned Business conditional license holder shall not make any ownership interest transfer that causes the license applicant to no longer comply with the Diversely-Owned business criteria, pursuant to N.J.A.C. 17:30-6.4;
2. An Impact Zone Business conditional license holder shall not make any ownership interest transfer that causes the license applicant to no longer comply with the Impact Zone Business criteria, pursuant to N.J.A.C. 17:30-6.5;

3. A Social Equity Business conditional license holder shall not make any ownership interest transfer that causes the license applicant to no longer comply with the Social Equity Business criteria, pursuant to N.J.A.C. 17:30-6.6;
4. A Microbusiness conditional license holder shall not make any ownership interest transfer that causes the license applicant to no longer comply with the Microbusiness criteria, pursuant to N.J.A.C. 17:30-6.7; and
5. A conditional license holder shall not violate the limitations on owners and principals, pursuant to N.J.A.C. 17:30-6.8.

Prior to the end of the conditional license phase, the applicant must submit its conditional cannabis business conversion application pursuant to N.J.A.C. 17:30-7.8. If granted, the license will be converted from a conditional license to an annual license, subject to all conditions set forth in N.J.A.C. 17:30-7.9 through 7.14.

As a conditional license awardee, you are subject to the New Jersey Cannabis Regulatory, Enforcement Assistance, and Marketplace Modernization (“CREAMM”) Act as well as all regulations implementing the CREAMM Act, set forth at N.J.A.C. 17:30. The NJ-CRC recommends that you familiarize yourself with those sections of the regulation pertaining to conditional cannabis licenses, specifically N.J.A.C. 17:30-7.2 through 7.8.

Again, congratulations on your successful application and thank you for your interest in working with the NJ-CRC to establish a safe and equitable cannabis industry for the state of New Jersey. Should you have any questions regarding this correspondence, please submit your inquiry to the NJ-CRC Licensing inbox at crc.licensing@crc.nj.gov.

Sincerely,

A handwritten signature in black ink, appearing to be 'DH' with a long horizontal line extending to the right.

Dianna Houenou
Chairperson
New Jersey Cannabis Regulatory Commission

PROJECT DESCRIPTION

PROJECT: SEA GRASS NJ INTERIOR RENOVATIONS / COMMERCIAL FIT-OUT
 272 BAY AVENUE, SUITE 100, HIGHLANDS, NJ 07732
 PROJECT DESCRIPTION: COMMERCIAL (S.B.H. OCCUPANCY)
 EXISTING INTERIOR FINISHES TO REMAIN WHERE FEASIBLE. REMOVE AND RELOCATE ALL INTERIOR PARTITIONS, WALLS, CEILING, FLOORING, AND MECHANICAL SYSTEMS AS SHOWN AND RELOCATED TO ACCOMMODATE THE PROPOSED OFFICE SPACE TO ACCOMMODATE WEST FLOOR BUSINESS.

Sea Grass NJ

Interior Renovations / Commercial Fit-Out
 272 Bay Avenue, Borough of Highlands, NJ 07732
 Block 72, Lot 12

DRAWING LIST

A1 COVER SHEET & DEMO
 A2 PROPOSED FLOOR PLANS
 A3 EXTERIOR ELEVATIONS

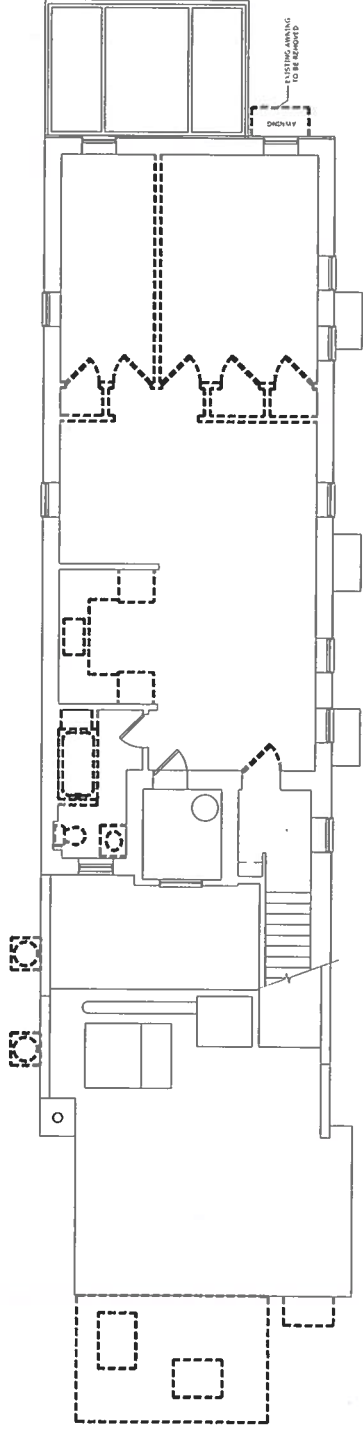

SECOND FLOOR DEMOLITION PLAN
 1/4" = 1'-0"

RELOCATE: ALL EXISTING MECHANICAL SYSTEMS TO THE SECOND FLOOR AS SHOWN.

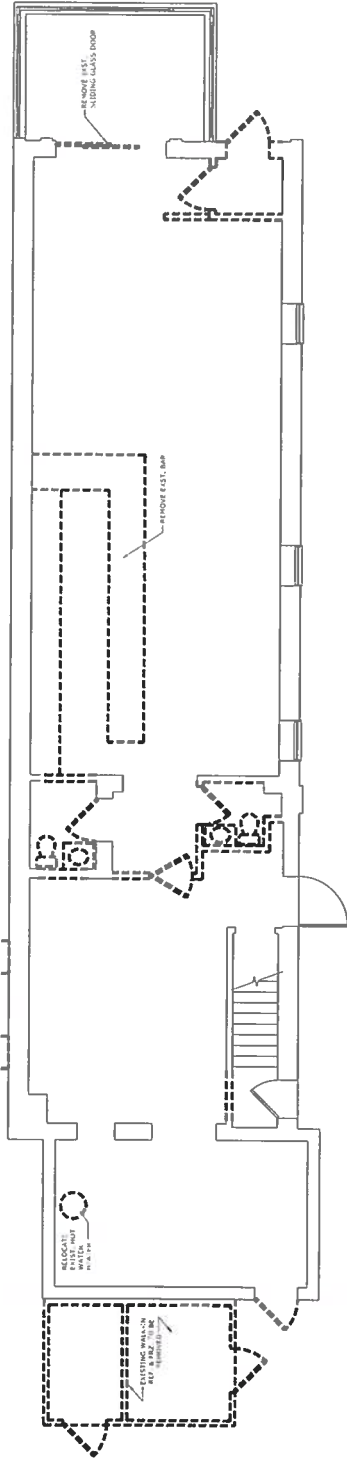

FIRST FLOOR DEMOLITION PLAN
 1/4" = 1'-0"



DEMOLITION NOTES

VERIFY ALL EXISTING CONDITIONS IN FIELD PRIOR TO DEMOLITION. EXISTING CONDITIONS MAY VARY FROM AS SHOWN. CONTRACTOR TO VERIFY EXISTING CONDITIONS WITH ARCHITECT PRIOR TO DEMOLITION. CONTRACTOR TO PROVIDE TEMPORARY SUPPORT FOR ALL STRUCTURAL BEARING MEMBERS PRIOR TO DEMOLITION. CONTRACTOR TO VERIFY ALL EXISTING ELECTRICAL & PLUMBING AS SHOWN PRIOR TO DEMOLITION. CONTRACTOR TO VERIFY ALL EXISTING MECHANICAL SYSTEMS TO BE DEMOLISHED PRIOR TO DEMOLITION. CONTRACTOR TO VERIFY ALL EXISTING MECHANICAL SYSTEMS TO BE DEMOLISHED PRIOR TO DEMOLITION. CONTRACTOR TO VERIFY ALL EXISTING MECHANICAL SYSTEMS TO BE DEMOLISHED PRIOR TO DEMOLITION. CONTRACTOR TO VERIFY ALL EXISTING MECHANICAL SYSTEMS TO BE DEMOLISHED PRIOR TO DEMOLITION. CONTRACTOR TO VERIFY ALL EXISTING MECHANICAL SYSTEMS TO BE DEMOLISHED PRIOR TO DEMOLITION.

SHISSIAS DESIGN + DEVELOPMENT
 154 445 0565
 1000 RIVER ST., SUITE 200
 WESTFIELD, NJ 07090

SEA GRASS NJ
 BLOCK 72, LOT 12
 272 BAY AVENUE, BOROUGH OF HIGHLANDS, NJ 07732

SEA GRASS NJ
 Interior Renovations / Commercial Fit-Out
 Block 72, Lot 12
 272 Bay Avenue, Borough of Highlands, NJ 07732

Fig. No. 2022A1
 Issued For: Board Approval
 Date: 12/21/2022

COVER SHEET & DEMO
A1

1 of 3



ALL WORK SHALL BE IN ACCORDANCE WITH THE 2018 INTERNATIONAL BUILDING CODE (IBC) AND ALL APPLICABLE LOCAL, STATE AND FEDERAL REGULATIONS. THE CONTRACTOR SHALL BE RESPONSIBLE FOR OBTAINING ALL NECESSARY PERMITS AND APPROVALS FROM THE APPROPRIATE AGENCIES. THE CONTRACTOR SHALL BE RESPONSIBLE FOR OBTAINING ALL NECESSARY PERMITS AND APPROVALS FROM THE APPROPRIATE AGENCIES. THE CONTRACTOR SHALL BE RESPONSIBLE FOR OBTAINING ALL NECESSARY PERMITS AND APPROVALS FROM THE APPROPRIATE AGENCIES.

Sea Grass NJ
 Interior Renovations / Commercial Fit-Out
 272 Bay Avenue, Borough of Highlands, NJ 07732
 Block 72, Lot 12

Proj. No. 2022-31
 Issued For: Board Approval
 Date: 12/2/2022

PROPOSED FLOOR PLANS

A2
 2 of 3

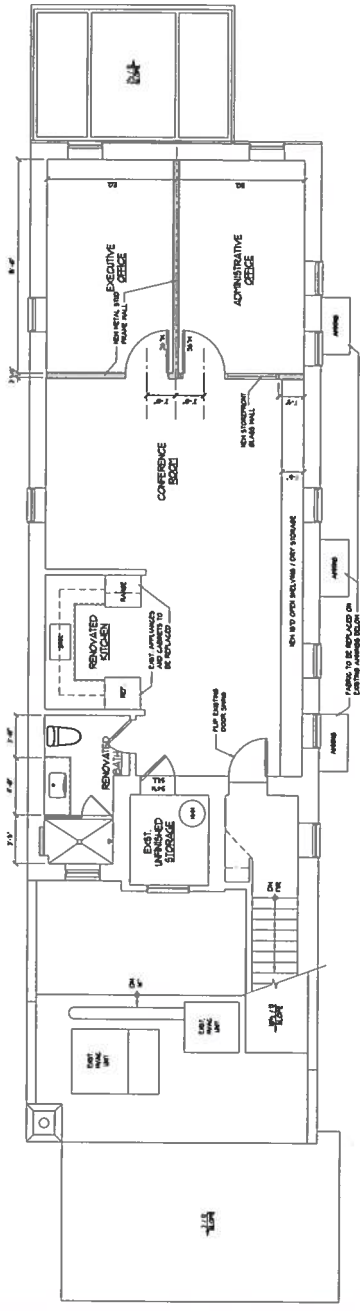

2 SECOND FLOOR PLAN
 1/4" = 1'-0"

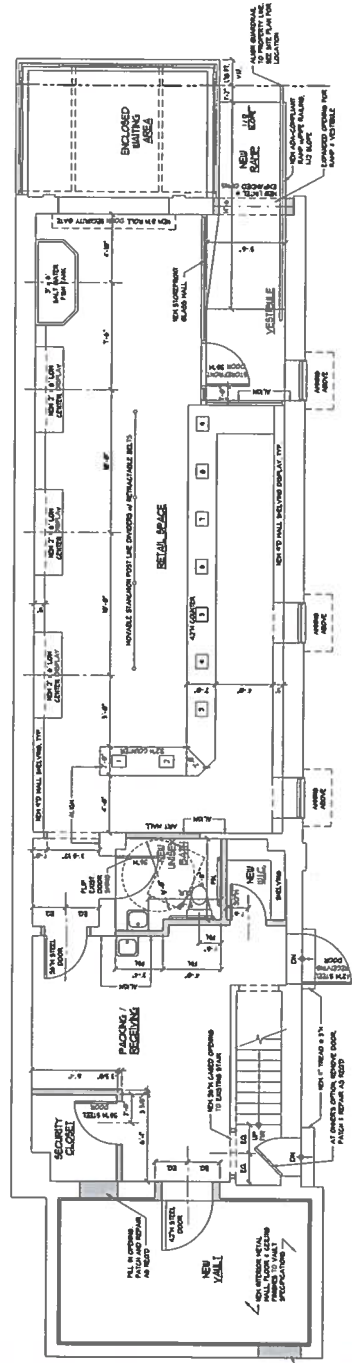

1 FIRST FLOOR PLAN
 1/4" = 1'-0"

PRELIMINARY & FINAL MAJOR SITE PLAN SEA GRASS NJ, LLC BLOCK 72, LOT 12 & BLOCK 73, LOT 2 BOROUGH OF HIGHLANDS MONMOUTH COUNTY, NEW JERSEY

UTILITY COMPANY CONTACTS:
APRIL:
 PO Box 3511
 Hammonton, NJ 08035
 856-537-2740
ANGLICAN COMMUNITY CENTER:
 1010 Route 22
 Hammonton, NJ 08035
CONCRETE CONSTRUCTION:
 222 York St.
 Hammonton, NJ 08035
CONCRETE CONSTRUCTION:
 1010 Route 22
 Hammonton, NJ 08035
CONCRETE CONSTRUCTION:
 222 York St.
 Hammonton, NJ 08035
CONCRETE CONSTRUCTION:
 1010 Route 22
 Hammonton, NJ 08035
CONCRETE CONSTRUCTION:
 222 York St.
 Hammonton, NJ 08035

PROPERTY OWNERS WITHIN 200' [Z]

OWNER NAME	ADDRESS	CITY	STATE	ZIP
1. [Name]	[Address]	[City]	[State]	[Zip]
2. [Name]	[Address]	[City]	[State]	[Zip]
3. [Name]	[Address]	[City]	[State]	[Zip]
4. [Name]	[Address]	[City]	[State]	[Zip]
5. [Name]	[Address]	[City]	[State]	[Zip]
6. [Name]	[Address]	[City]	[State]	[Zip]
7. [Name]	[Address]	[City]	[State]	[Zip]
8. [Name]	[Address]	[City]	[State]	[Zip]
9. [Name]	[Address]	[City]	[State]	[Zip]
10. [Name]	[Address]	[City]	[State]	[Zip]



KEY MAP
SCALE: 1" = 2000'



TAX MAP 72 & 73
SCALE: 1" = 2000'



REDEVELOPMENT ZONE MAP
SCALE: 1" = 2000'

SHEET NO.	DATE	REVISION
1	11/27/22	
2	11/27/22	
3	11/27/22	
4	11/27/22	
5	11/27/22	
6	11/27/22	
7	11/27/22	
8	11/27/22	
9	11/27/22	
10	11/27/22	

I HEREBY CERTIFY THAT I AM OWNER OF RECORD OF THE SITE HEREIN DEPICTED AND THAT I CONCUR WITH THE PLANS OF THIS PLAN. THE SITE IS NOT SUBJECT OF ANY UNSATURATED MORTGAGE. THE ENTIRE SITE IS BEING OFFERED FOR SALE. THE SITE IS BEING OFFERED FOR SALE AS PART OF A DEVELOPMENT PROJECT. THE SITE IS BEING OFFERED FOR SALE AS PART OF A DEVELOPMENT PROJECT. THE SITE IS BEING OFFERED FOR SALE AS PART OF A DEVELOPMENT PROJECT.

OWNER:
LEONEL CERVANTES
272 BAY AVENUE
HIGHLANDS, NJ 07732

APPLICANT:
SEA GRASS NJ, LLC
135 MAPLE AVENUE
RED BANK, NJ 07701

OWNER	DATE	APPLICANT	DATE

PRELIMINARY & FINAL MAJOR SITE PLAN COVER SHEET
 BLOCK 72, LOT 12 & BLOCK 73, LOT 2
 HIGHLANDS BOROUGHS, NEW JERSEY
 THE BOARD OF ZONING ADJUSTMENTS
 11 South New Street
 HIGHLANDS, NJ 07732
 TELEPHONE: (908) 581-2200

ZONING BOARD
 CASE NO. ZB-2023-XX
 SHEET NO. 1 OF 10

LAND USE	PERMITTED
1. RESIDENTIAL SINGLE-FAMILY	PERMITTED
2. RESIDENTIAL MULTIFAMILY	PERMITTED
3. COMMERCIAL GENERAL BUSINESS	PERMITTED
4. OFFICE	PERMITTED
5. MANUFACTURING	PERMITTED
6. UTILITIES	PERMITTED
7. PUBLIC USE	PERMITTED
8. INTERMEDIATE USES	PERMITTED
9. AGRICULTURE	PERMITTED
10. RETAIL	PERMITTED
11. FOOD SERVICE	PERMITTED
12. DRUG STORE	PERMITTED
13. PHOTO FINISHING	PERMITTED
14. PRINTING	PERMITTED
15. SHIRT FABRICATING	PERMITTED
16. SIGN MANUFACTURING	PERMITTED
17. SIGN INSTALLATION	PERMITTED
18. SIGN MAINTENANCE	PERMITTED
19. SIGN REMOVAL	PERMITTED
20. SIGN REPAIR	PERMITTED
21. SIGN STORAGE	PERMITTED
22. SIGN TRANSPORT	PERMITTED
23. SIGN USE	PERMITTED
24. SIGN WEAR AND TEAR	PERMITTED
25. SIGN WRECKING	PERMITTED
26. SIGN YARD	PERMITTED
27. SIGN WORKSHOP	PERMITTED
28. SIGN DISTRIBUTION	PERMITTED
29. SIGN SALES	PERMITTED
30. SIGN REPAIR AND MAINTENANCE	PERMITTED
31. SIGN STORAGE AND DISTRIBUTION	PERMITTED
32. SIGN WRECKING AND REMOVAL	PERMITTED
33. SIGN YARD AND STORAGE	PERMITTED
34. SIGN WORKSHOP AND STORAGE	PERMITTED
35. SIGN DISTRIBUTION AND STORAGE	PERMITTED
36. SIGN SALES AND STORAGE	PERMITTED
37. SIGN REPAIR AND STORAGE	PERMITTED
38. SIGN WRECKING AND STORAGE	PERMITTED
39. SIGN YARD AND STORAGE	PERMITTED
40. SIGN WORKSHOP AND STORAGE	PERMITTED

LAND USE	PERMITTED
1. RESIDENTIAL SINGLE-FAMILY	PERMITTED
2. RESIDENTIAL MULTIFAMILY	PERMITTED
3. COMMERCIAL GENERAL BUSINESS	PERMITTED
4. OFFICE	PERMITTED
5. MANUFACTURING	PERMITTED
6. UTILITIES	PERMITTED
7. PUBLIC USE	PERMITTED
8. INTERMEDIATE USES	PERMITTED
9. AGRICULTURE	PERMITTED
10. RETAIL	PERMITTED
11. FOOD SERVICE	PERMITTED
12. DRUG STORE	PERMITTED
13. PHOTO FINISHING	PERMITTED
14. PRINTING	PERMITTED
15. SHIRT FABRICATING	PERMITTED
16. SIGN MANUFACTURING	PERMITTED
17. SIGN INSTALLATION	PERMITTED
18. SIGN MAINTENANCE	PERMITTED
19. SIGN REMOVAL	PERMITTED
20. SIGN REPAIR	PERMITTED
21. SIGN STORAGE	PERMITTED
22. SIGN TRANSPORT	PERMITTED
23. SIGN USE	PERMITTED
24. SIGN WEAR AND TEAR	PERMITTED
25. SIGN WRECKING	PERMITTED
26. SIGN YARD	PERMITTED
27. SIGN WORKSHOP	PERMITTED
28. SIGN DISTRIBUTION	PERMITTED
29. SIGN SALES	PERMITTED
30. SIGN REPAIR AND MAINTENANCE	PERMITTED
31. SIGN STORAGE AND DISTRIBUTION	PERMITTED
32. SIGN WRECKING AND REMOVAL	PERMITTED
33. SIGN YARD AND STORAGE	PERMITTED
34. SIGN WORKSHOP AND STORAGE	PERMITTED
35. SIGN DISTRIBUTION AND STORAGE	PERMITTED
36. SIGN SALES AND STORAGE	PERMITTED
37. SIGN REPAIR AND STORAGE	PERMITTED
38. SIGN WRECKING AND STORAGE	PERMITTED
39. SIGN YARD AND STORAGE	PERMITTED
40. SIGN WORKSHOP AND STORAGE	PERMITTED

LAND USE	PERMITTED
1. RESIDENTIAL SINGLE-FAMILY	PERMITTED
2. RESIDENTIAL MULTIFAMILY	PERMITTED
3. COMMERCIAL GENERAL BUSINESS	PERMITTED
4. OFFICE	PERMITTED
5. MANUFACTURING	PERMITTED
6. UTILITIES	PERMITTED
7. PUBLIC USE	PERMITTED
8. INTERMEDIATE USES	PERMITTED
9. AGRICULTURE	PERMITTED
10. RETAIL	PERMITTED
11. FOOD SERVICE	PERMITTED
12. DRUG STORE	PERMITTED
13. PHOTO FINISHING	PERMITTED
14. PRINTING	PERMITTED
15. SHIRT FABRICATING	PERMITTED
16. SIGN MANUFACTURING	PERMITTED
17. SIGN INSTALLATION	PERMITTED
18. SIGN MAINTENANCE	PERMITTED
19. SIGN REMOVAL	PERMITTED
20. SIGN REPAIR	PERMITTED
21. SIGN STORAGE	PERMITTED
22. SIGN TRANSPORT	PERMITTED
23. SIGN USE	PERMITTED
24. SIGN WEAR AND TEAR	PERMITTED
25. SIGN WRECKING	PERMITTED
26. SIGN YARD	PERMITTED
27. SIGN WORKSHOP	PERMITTED
28. SIGN DISTRIBUTION	PERMITTED
29. SIGN SALES	PERMITTED
30. SIGN REPAIR AND MAINTENANCE	PERMITTED
31. SIGN STORAGE AND DISTRIBUTION	PERMITTED
32. SIGN WRECKING AND REMOVAL	PERMITTED
33. SIGN YARD AND STORAGE	PERMITTED
34. SIGN WORKSHOP AND STORAGE	PERMITTED
35. SIGN DISTRIBUTION AND STORAGE	PERMITTED
36. SIGN SALES AND STORAGE	PERMITTED
37. SIGN REPAIR AND STORAGE	PERMITTED
38. SIGN WRECKING AND STORAGE	PERMITTED
39. SIGN YARD AND STORAGE	PERMITTED
40. SIGN WORKSHOP AND STORAGE	PERMITTED

GENERAL LEGEND

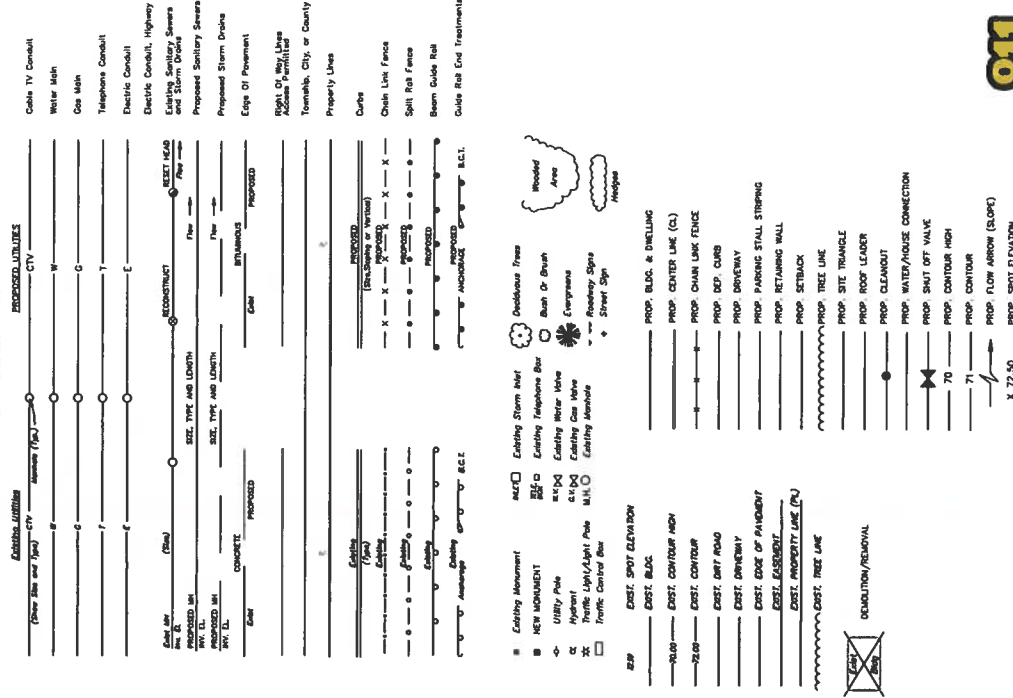

GENERAL NOTES

- THE PROPERTY IS SHOWN AS LOT 12, BLOCK 73 ON SHEETS 10 & 14 OF THE OFFICIAL MAP OF THE BOROUGHS OF HIGHLAND, WASHINGTON COUNTY, NEW JERSEY.
- OWNER: [Redacted]
- APPLICANT: [Redacted]
- THE PROJECT SHALL BE CONFORMANT WITH THE ZONING ORDINANCES OF THE BOROUGHS OF HIGHLAND, WASHINGTON COUNTY, NEW JERSEY.
- THE PROJECT SHALL BE CONFORMANT WITH THE SUBDIVISION MAP ACT, NEW JERSEY, AND THE SUBDIVISION MAP ACT REGULATIONS, NEW JERSEY.
- THE PROJECT SHALL BE CONFORMANT WITH THE PLANNING AND ZONING ACT, NEW JERSEY, AND THE PLANNING AND ZONING REGULATIONS, NEW JERSEY.
- THE PROJECT SHALL BE CONFORMANT WITH THE ENVIRONMENTAL IMPACT STATEMENT, NEW JERSEY, AND THE ENVIRONMENTAL IMPACT STATEMENT REGULATIONS, NEW JERSEY.
- THE PROJECT SHALL BE CONFORMANT WITH THE HISTORIC PRESERVATION ACT, NEW JERSEY, AND THE HISTORIC PRESERVATION REGULATIONS, NEW JERSEY.
- THE PROJECT SHALL BE CONFORMANT WITH THE OPEN SPACE PRESERVATION ACT, NEW JERSEY, AND THE OPEN SPACE PRESERVATION REGULATIONS, NEW JERSEY.
- THE PROJECT SHALL BE CONFORMANT WITH THE OPEN SPACE PRESERVATION ACT, NEW JERSEY, AND THE OPEN SPACE PRESERVATION REGULATIONS, NEW JERSEY.
- THE PROJECT SHALL BE CONFORMANT WITH THE OPEN SPACE PRESERVATION ACT, NEW JERSEY, AND THE OPEN SPACE PRESERVATION REGULATIONS, NEW JERSEY.
- THE PROJECT SHALL BE CONFORMANT WITH THE OPEN SPACE PRESERVATION ACT, NEW JERSEY, AND THE OPEN SPACE PRESERVATION REGULATIONS, NEW JERSEY.
- THE PROJECT SHALL BE CONFORMANT WITH THE OPEN SPACE PRESERVATION ACT, NEW JERSEY, AND THE OPEN SPACE PRESERVATION REGULATIONS, NEW JERSEY.
- THE PROJECT SHALL BE CONFORMANT WITH THE OPEN SPACE PRESERVATION ACT, NEW JERSEY, AND THE OPEN SPACE PRESERVATION REGULATIONS, NEW JERSEY.
- THE PROJECT SHALL BE CONFORMANT WITH THE OPEN SPACE PRESERVATION ACT, NEW JERSEY, AND THE OPEN SPACE PRESERVATION REGULATIONS, NEW JERSEY.

UTITIES

- THE UTILITY LINES SHOWN ON THIS PLAN ARE BASED ON THE RECORD DRAWINGS AND FIELD SURVEY DATA. THE CONTRACTOR SHALL VERIFY THE LOCATION AND DEPTH OF ALL UTILITY LINES PRIOR TO CONSTRUCTION. ANY UNEXPECTED UTILITY LINES SHALL BE REPORTED IMMEDIATELY TO THE ENGINEER AND THE BOROUGHS OF HIGHLAND, WASHINGTON COUNTY, NEW JERSEY.
- THE CONTRACTOR SHALL BE RESPONSIBLE FOR THE PROTECTION AND REPAIR OF ALL UTILITY LINES. ANY DAMAGE TO UTILITY LINES SHALL BE REPAIRED AT THE CONTRACTOR'S EXPENSE.
- THE CONTRACTOR SHALL BE RESPONSIBLE FOR THE PROTECTION AND REPAIR OF ALL UTILITY LINES. ANY DAMAGE TO UTILITY LINES SHALL BE REPAIRED AT THE CONTRACTOR'S EXPENSE.
- THE CONTRACTOR SHALL BE RESPONSIBLE FOR THE PROTECTION AND REPAIR OF ALL UTILITY LINES. ANY DAMAGE TO UTILITY LINES SHALL BE REPAIRED AT THE CONTRACTOR'S EXPENSE.
- THE CONTRACTOR SHALL BE RESPONSIBLE FOR THE PROTECTION AND REPAIR OF ALL UTILITY LINES. ANY DAMAGE TO UTILITY LINES SHALL BE REPAIRED AT THE CONTRACTOR'S EXPENSE.
- THE CONTRACTOR SHALL BE RESPONSIBLE FOR THE PROTECTION AND REPAIR OF ALL UTILITY LINES. ANY DAMAGE TO UTILITY LINES SHALL BE REPAIRED AT THE CONTRACTOR'S EXPENSE.
- THE CONTRACTOR SHALL BE RESPONSIBLE FOR THE PROTECTION AND REPAIR OF ALL UTILITY LINES. ANY DAMAGE TO UTILITY LINES SHALL BE REPAIRED AT THE CONTRACTOR'S EXPENSE.
- THE CONTRACTOR SHALL BE RESPONSIBLE FOR THE PROTECTION AND REPAIR OF ALL UTILITY LINES. ANY DAMAGE TO UTILITY LINES SHALL BE REPAIRED AT THE CONTRACTOR'S EXPENSE.
- THE CONTRACTOR SHALL BE RESPONSIBLE FOR THE PROTECTION AND REPAIR OF ALL UTILITY LINES. ANY DAMAGE TO UTILITY LINES SHALL BE REPAIRED AT THE CONTRACTOR'S EXPENSE.
- THE CONTRACTOR SHALL BE RESPONSIBLE FOR THE PROTECTION AND REPAIR OF ALL UTILITY LINES. ANY DAMAGE TO UTILITY LINES SHALL BE REPAIRED AT THE CONTRACTOR'S EXPENSE.
- THE CONTRACTOR SHALL BE RESPONSIBLE FOR THE PROTECTION AND REPAIR OF ALL UTILITY LINES. ANY DAMAGE TO UTILITY LINES SHALL BE REPAIRED AT THE CONTRACTOR'S EXPENSE.
- THE CONTRACTOR SHALL BE RESPONSIBLE FOR THE PROTECTION AND REPAIR OF ALL UTILITY LINES. ANY DAMAGE TO UTILITY LINES SHALL BE REPAIRED AT THE CONTRACTOR'S EXPENSE.
- THE CONTRACTOR SHALL BE RESPONSIBLE FOR THE PROTECTION AND REPAIR OF ALL UTILITY LINES. ANY DAMAGE TO UTILITY LINES SHALL BE REPAIRED AT THE CONTRACTOR'S EXPENSE.
- THE CONTRACTOR SHALL BE RESPONSIBLE FOR THE PROTECTION AND REPAIR OF ALL UTILITY LINES. ANY DAMAGE TO UTILITY LINES SHALL BE REPAIRED AT THE CONTRACTOR'S EXPENSE.
- THE CONTRACTOR SHALL BE RESPONSIBLE FOR THE PROTECTION AND REPAIR OF ALL UTILITY LINES. ANY DAMAGE TO UTILITY LINES SHALL BE REPAIRED AT THE CONTRACTOR'S EXPENSE.

SAFETY NOTE

ALL CONSTRUCTION WORK SHALL BE PERFORMED IN ACCORDANCE WITH ALL APPLICABLE SAFETY REGULATIONS AND ORDINANCES, INCLUDING BUT NOT LIMITED TO THE FEDERAL DEPARTMENT OF LABOR, OCCUPATIONAL SAFETY AND HEALTH ADMINISTRATION'S "CONSTRUCTION SAFETY AND HEALTH REGULATIONS," NEW JERSEY DEPARTMENT OF LABOR AND INDUSTRY, BUREAU OF ENGINEERING AND SAFETY, "CONSTRUCTION SAFETY CODE" AND "MAINTENANCE, CONSTRUCTION AND DEMOLITION," AND BUILDING CODE.



THE CONTRACTOR SHALL BE RESPONSIBLE FOR THE PROTECTION AND REPAIR OF ALL UTILITY LINES. ANY DAMAGE TO UTILITY LINES SHALL BE REPAIRED AT THE CONTRACTOR'S EXPENSE.

PRELIMINARY & FINAL MAJOR SITE PLAN
SEA GRABB NJ, LLC
GENERAL NOTES
 11 March 2018
 1401 HIGHLAND AVENUE, SUITE 100
 HIGHLAND, NJ 07732
 908.983.1111
 SEA GRABB NJ, LLC
 11/21/22
 SHEET NO. 2 OF 10

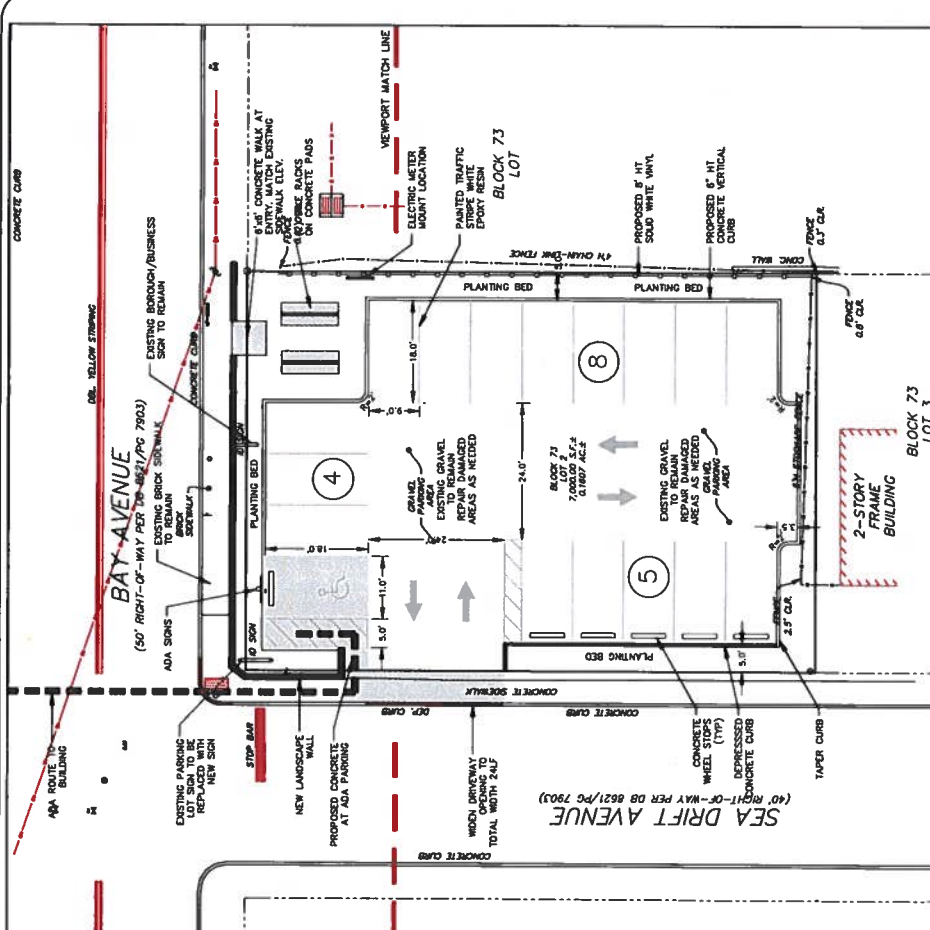
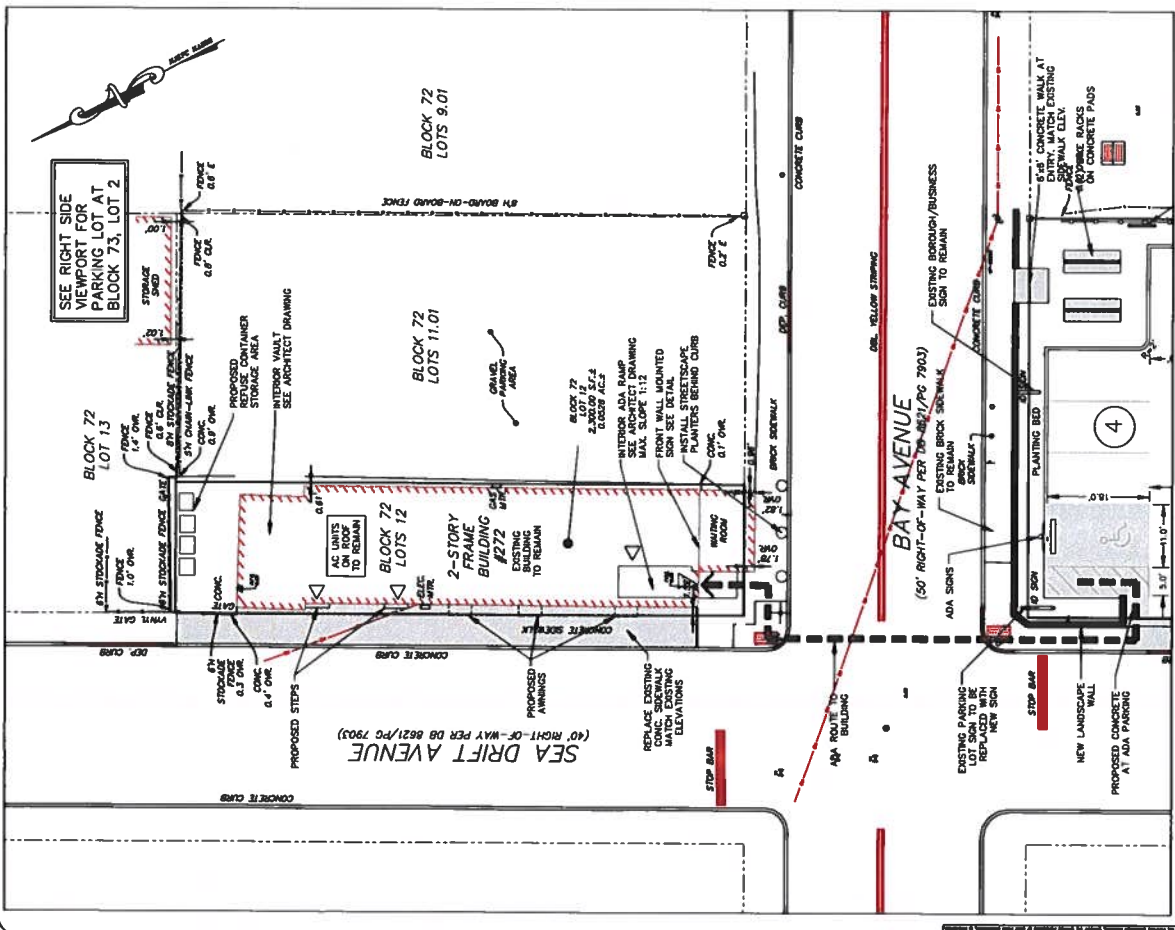

- SITE IMPROVEMENT NOTES**
1. ALL SIGN, STRIPES, AND SIGNS FOR THE MAINTENANCE AND PROTECTION OF TRAFFIC SHALL BE IN ACCORDANCE WITH THE MANUAL ON UNIFORM CONTROLLED SIGNALS (MUTCD) LATEST EDITION.
 2. ALL SIGN, STRIPES, AND SIGNS SHALL BE CONSTRUCTED OF ALUMINUM OR STEEL AND SHALL BE CONSTRUCTED TO WITHSTAND A WIND SPEED OF 100 MPH AS DETERMINED BY THE APPLICABLE CODES.
 3. ALL SIGN, STRIPES, AND SIGNS SHALL BE CONSTRUCTED OF ALUMINUM OR STEEL AND SHALL BE CONSTRUCTED TO WITHSTAND A WIND SPEED OF 100 MPH AS DETERMINED BY THE APPLICABLE CODES.
 4. SIGNAGE, LAMP, AND CURBS TO BE CONSTRUCTED OF ALUMINUM OR STEEL AS INDICATED ON THE CONSTRUCTION DETAILS.
 5. CONSTRUCTION SHALL BE IN ACCORDANCE WITH THE APPLICABLE CODES AND APPROVAL FROM THE LOCAL HEALTH DEPARTMENT SHALL BE OBTAINED PRIOR TO CONSTRUCTION.
 6. DEPRESSIONS SHALL BE CONSTRUCTED OUT OF CONCRETE.
 7. ANY CURBS OR SIGNAGE REMOVED BY THE MAINTENANCE DEPARTMENT SHALL BE REPLACED.

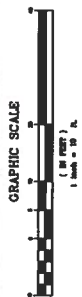

PRELIMINARY & FINAL MAJOR SITE PLAN

SITE LAYOUT / SIGNAGE & STRIPING PLAN

SEA GRABBS NA, LLC
 11000 W. 11TH AVENUE, SUITE 100
 DENVER, CO 80231-1100
 PHONE: 303.752.0700
 FAX: 303.752.0700

EAST POINT ENGINEERING, LLC
 1100 W. 11TH AVENUE, SUITE 100
 DENVER, CO 80231-1100
 PHONE: 303.752.0700
 FAX: 303.752.0700

DATE: 11/21/22
 DRAWN BY: J. W. B. S.
 CHECKED BY: J. W. B. S.
 SHEET NO. 4 OF 10

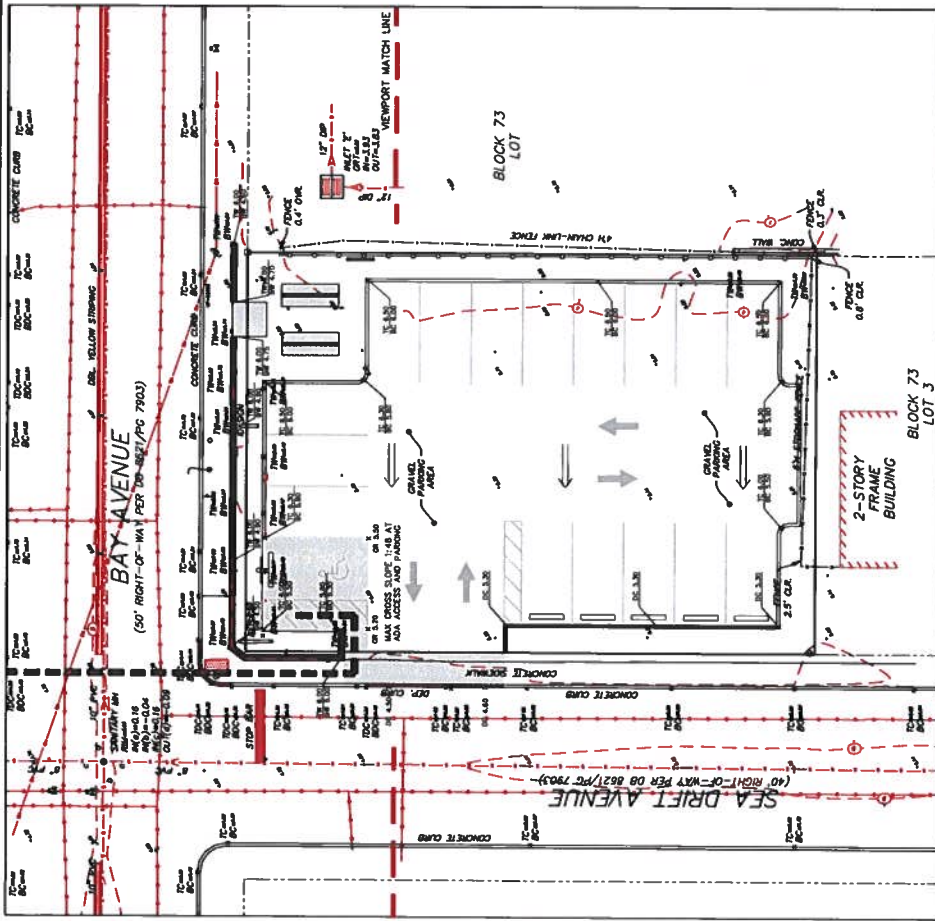
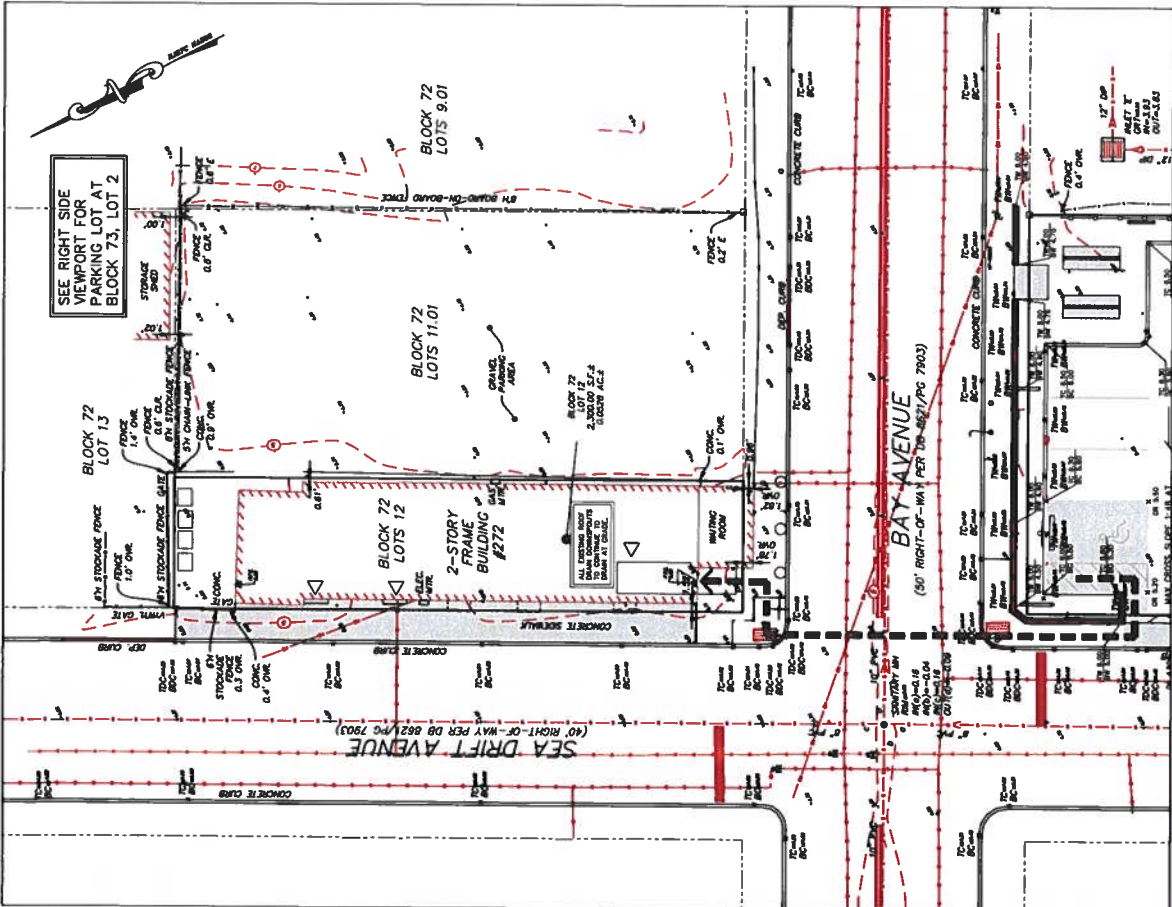

PRELIMINARY & FINAL MAJOR SITE PLAN
 SEA BARRS MARINA
 GRADING PLAN
 BLOCK 72, LOT 1 & 3, BLOCK 73, LOT 3
 HIGHWAY 100, NEW JERSEY
 HILLSBORO, NEW JERSEY 08041-1000

EAST POINT ENGINEERING, LLC
 11 South High Street
 Hillsborough, NJ 08041
 TEL: 732.277.8338
 FAX: 732.277.8339
 www.eastpointeng.com

DATE: 11/21/22
 SHEET NO. 5 OF 10

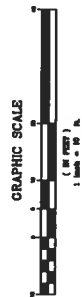

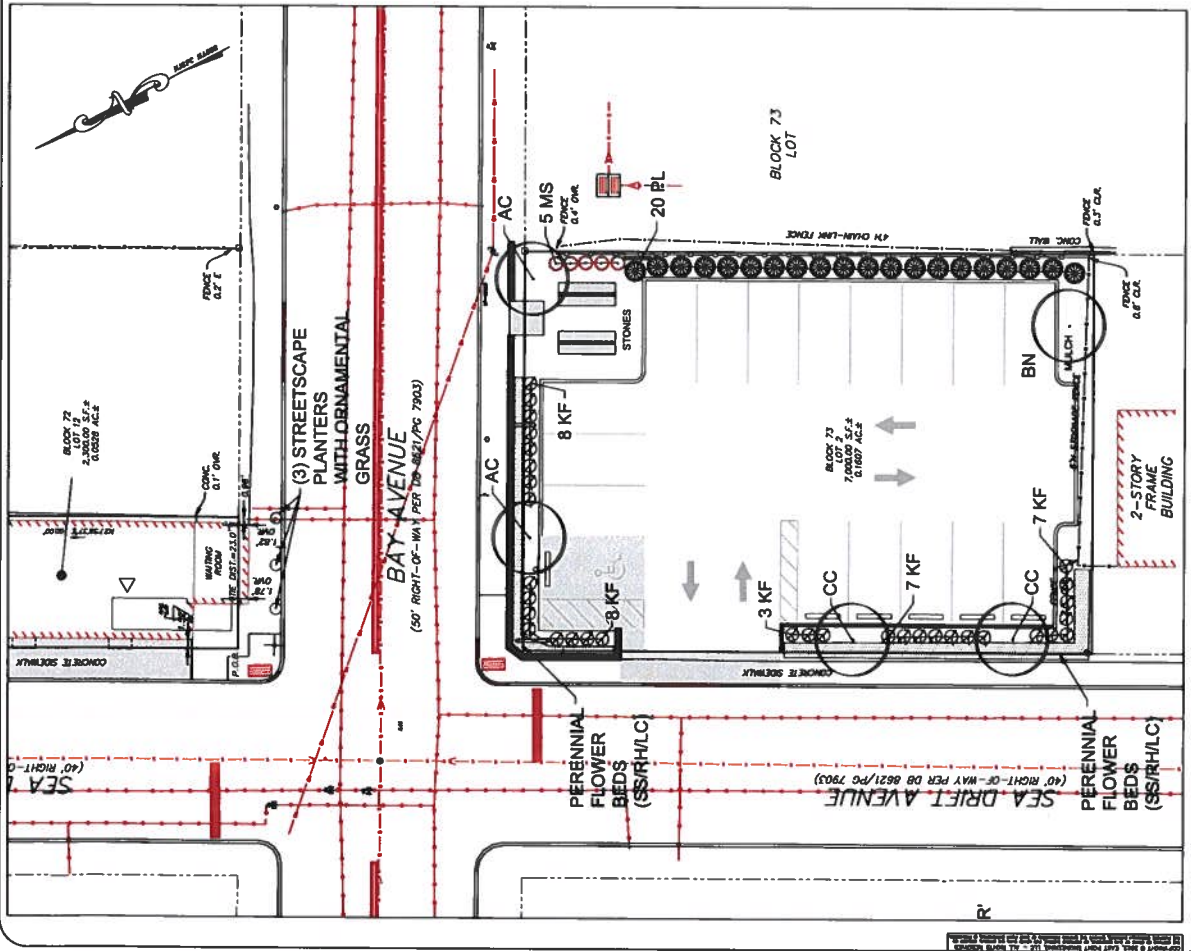

KEY	QTY	BOTANICAL NAME	COMMON NAME	HT./CONTAINER SIZE	REMARKS
Deciduous Trees:					
BN	1	Betula Nigra 'Culm'	Hellgate Blue Birch	2.5" - 3.0" cal.	B&B, Straight Central Leader
CC	2	Cercis Canadensis	Eastern Redbud	4-5" Ht.	B&B, Straight Central Leader
AC	2	Ampelancher Canadensis	Shoebow Sen-Ascabery	4-5" Ht.	B&B, Straight Central Leader
Shrubs:					
PL	20	Punus Laureocerasus 'Schubertii'	Slip Cherry Laurel	3 Gal.	
Ornamental Grasses:					
MS	5	Miscanthus Sinensis 'Silchus'	Parrotgrass Grass	3 Gal.	
KF	33	Calamagrostis x Acutiflora	Karl Foerster's Feathered Reed Grass	3 Gal.	
Perennial Flowers (M&S):					
SS		Solidago Semperparva	Scallop Goldenrod	3 Gal.	
RH		Rubusida Hirta	Black-eyed Susan	3 Gal.	
LC		Labella Canadensis	Cardinal Flower	3 Gal.	

PLANTING NOTES:

1. ALL PLANT MATERIAL SHALL BE INSTALLED AS PER DETAILS, NOTES AND CONTRACT REVISED DRAWINGS. THE CONTRACTOR SHALL BE RESPONSIBLE FOR OBTAINING ALL NECESSARY PERMITS AND APPROVALS FROM THE CITY OF SEASIDE AND THE CALIFORNIA DEPARTMENT OF WATER RESOURCES. THE CONTRACTOR SHALL CONTACT UTILITY ENTITIES FOR MARK-OUT OF EXISTING UTILITIES PRIOR TO ANY EXCAVATION ACTIVITIES. THE PROJECT MANAGER SHALL BE RESPONSIBLE FOR OBTAINING ALL NECESSARY PERMITS AND APPROVALS FROM THE CITY OF SEASIDE AND THE CALIFORNIA DEPARTMENT OF WATER RESOURCES. THE CONTRACTOR SHALL BE RESPONSIBLE FOR OBTAINING ALL NECESSARY PERMITS AND APPROVALS FROM THE CITY OF SEASIDE AND THE CALIFORNIA DEPARTMENT OF WATER RESOURCES.
2. CONTRACTOR SHALL CONTACT UTILITY ENTITIES FOR MARK-OUT OF EXISTING UTILITIES PRIOR TO ANY EXCAVATION ACTIVITIES. THE PROJECT MANAGER SHALL BE RESPONSIBLE FOR OBTAINING ALL NECESSARY PERMITS AND APPROVALS FROM THE CITY OF SEASIDE AND THE CALIFORNIA DEPARTMENT OF WATER RESOURCES. THE CONTRACTOR SHALL BE RESPONSIBLE FOR OBTAINING ALL NECESSARY PERMITS AND APPROVALS FROM THE CITY OF SEASIDE AND THE CALIFORNIA DEPARTMENT OF WATER RESOURCES.
3. SHADE AND EVERGREEN TREES SHALL BE FIELD ADJUSTED TO BE PLANTED AT THE CORRECT PLANTING LOCATION. THE CONTRACTOR SHALL BE RESPONSIBLE FOR OBTAINING ALL NECESSARY PERMITS AND APPROVALS FROM THE CITY OF SEASIDE AND THE CALIFORNIA DEPARTMENT OF WATER RESOURCES. THE CONTRACTOR SHALL BE RESPONSIBLE FOR OBTAINING ALL NECESSARY PERMITS AND APPROVALS FROM THE CITY OF SEASIDE AND THE CALIFORNIA DEPARTMENT OF WATER RESOURCES.
4. ALL PLANT MATERIAL SHALL BE INSTALLED AS PER DETAILS, NOTES AND CONTRACT REVISED DRAWINGS. THE CONTRACTOR SHALL BE RESPONSIBLE FOR OBTAINING ALL NECESSARY PERMITS AND APPROVALS FROM THE CITY OF SEASIDE AND THE CALIFORNIA DEPARTMENT OF WATER RESOURCES. THE CONTRACTOR SHALL BE RESPONSIBLE FOR OBTAINING ALL NECESSARY PERMITS AND APPROVALS FROM THE CITY OF SEASIDE AND THE CALIFORNIA DEPARTMENT OF WATER RESOURCES.
5. ALL PLANT MATERIAL SHALL BE INSTALLED AS PER DETAILS, NOTES AND CONTRACT REVISED DRAWINGS. THE CONTRACTOR SHALL BE RESPONSIBLE FOR OBTAINING ALL NECESSARY PERMITS AND APPROVALS FROM THE CITY OF SEASIDE AND THE CALIFORNIA DEPARTMENT OF WATER RESOURCES. THE CONTRACTOR SHALL BE RESPONSIBLE FOR OBTAINING ALL NECESSARY PERMITS AND APPROVALS FROM THE CITY OF SEASIDE AND THE CALIFORNIA DEPARTMENT OF WATER RESOURCES.
6. ALL LANDSCAPING WHICH IS NOT RESISTANT TO THE ENVIRONMENT OR THAT DIES WITHIN TWO YEARS OF PLANTING, SHALL BE REPLACED BY THE DEVELOPER, PLANTER AND CONTRACTOR. THE LANDSCAPE CONTRACTOR SHALL BE RESPONSIBLE FOR OBTAINING ALL NECESSARY PERMITS AND APPROVALS FROM THE CITY OF SEASIDE AND THE CALIFORNIA DEPARTMENT OF WATER RESOURCES. THE CONTRACTOR SHALL BE RESPONSIBLE FOR OBTAINING ALL NECESSARY PERMITS AND APPROVALS FROM THE CITY OF SEASIDE AND THE CALIFORNIA DEPARTMENT OF WATER RESOURCES.
7. THE CONTRACTOR SHALL KEEP THE AREA CLEAN DURING DELIVERY AND INSTALLATION OF PLANT MATERIALS. THE CONTRACTOR SHALL BE RESPONSIBLE FOR OBTAINING ALL NECESSARY PERMITS AND APPROVALS FROM THE CITY OF SEASIDE AND THE CALIFORNIA DEPARTMENT OF WATER RESOURCES. THE CONTRACTOR SHALL BE RESPONSIBLE FOR OBTAINING ALL NECESSARY PERMITS AND APPROVALS FROM THE CITY OF SEASIDE AND THE CALIFORNIA DEPARTMENT OF WATER RESOURCES.
8. IN THE EVENT THAT PLANT QUANTITY, DISCREPANCIES OR MATERIAL DISCREPANCIES OCCUR IN THE PLANTING SCHEDULE, THE PLANTER SHALL SUPPLEMENT.

PLANTING DETAILS:

- DECIDUOUS TREE PLANTING:** Includes diagrams for planting holes, mulch, and watering instructions.
- EVERGREEN TREE PLANTING:** Includes diagrams for planting holes, mulch, and watering instructions.
- TURF/MULCH BEDLINE DETAIL:** Shows cross-section of lawn and mulch layers.
- SHRUB PLANTING:** Includes diagrams for planting holes, mulch, and watering instructions.

GRAPHIC SCALE: 1 inch = 8 feet.

EAST POINT ENGINEERING, LLC
11 South High Street, Seaside, CA 94138
408-438-8888
www.eastpointeng.com

Luminaire Data - DB Lighting Consultation		
Label	Qty	Symbol
VA	1	(MANUFAC)
SL4s	3	Above All Lighting

Description		
LLF	Watts	LMH
0.850	18,909	2721
0.850	74,244	4764

Calculation Values - DB Lighting Consultation			
Units	Min	Avg/Min	Max/Min
All Values Project Area	6.3	0.0	N.A.
Illuminance	6.3	0.3	5.50
FC	1.65	6.3	21.00

ABOVE ALL
SMT LED AREA LIGHT

PRODUCT DESCRIPTION
 The product is a recessed, square, LED lighting fixture with a frosted lens and a black trim ring. It is designed for use in a variety of applications, including residential, commercial, and industrial.

PERFORMANCE

- 3000K color temperature
- 120V AC input
- 15W power consumption
- 1500 lumens output
- 100,000 hour life expectancy

ELECTRICAL SYSTEM

- 120V AC input
- 15W power consumption
- 1500 lumens output
- 100,000 hour life expectancy

FEATURES

- Recessed design
- Frosted lens
- Black trim ring
- 1500 lumens output
- 100,000 hour life expectancy

ABOVE ALL
SELECTABLE DIM WALL PACK
 Superior control and performance

PRODUCT DESCRIPTION
 The product is a rectangular, wall-mounted LED lighting fixture with a black finish and a frosted lens. It is designed for use in a variety of applications, including residential, commercial, and industrial.

PERFORMANCE

- 3000K color temperature
- 120V AC input
- 15W power consumption
- 1500 lumens output
- 100,000 hour life expectancy

ELECTRICAL SYSTEM

- 120V AC input
- 15W power consumption
- 1500 lumens output
- 100,000 hour life expectancy

FEATURES

- Selectable dimming
- Recessed design
- Frosted lens
- Black finish
- 1500 lumens output
- 100,000 hour life expectancy

ABOVE ALL LIGHTING
POLY MOUNTED EXTURE (S-45)

PRODUCT DESCRIPTION
 The product is a rectangular, wall-mounted LED lighting fixture with a black finish and a frosted lens. It is designed for use in a variety of applications, including residential, commercial, and industrial.

PERFORMANCE

- 3000K color temperature
- 120V AC input
- 15W power consumption
- 1500 lumens output
- 100,000 hour life expectancy

ELECTRICAL SYSTEM

- 120V AC input
- 15W power consumption
- 1500 lumens output
- 100,000 hour life expectancy

FEATURES

- Recessed design
- Frosted lens
- Black finish
- 1500 lumens output
- 100,000 hour life expectancy

ABOVE ALL LIGHTING
EGRILL WALL FIXTURE (WA)

PRODUCT DESCRIPTION
 The product is a rectangular, wall-mounted LED lighting fixture with a black finish and a frosted lens. It is designed for use in a variety of applications, including residential, commercial, and industrial.

PERFORMANCE

- 3000K color temperature
- 120V AC input
- 15W power consumption
- 1500 lumens output
- 100,000 hour life expectancy

ELECTRICAL SYSTEM

- 120V AC input
- 15W power consumption
- 1500 lumens output
- 100,000 hour life expectancy

FEATURES

- Recessed design
- Frosted lens
- Black finish
- 1500 lumens output
- 100,000 hour life expectancy

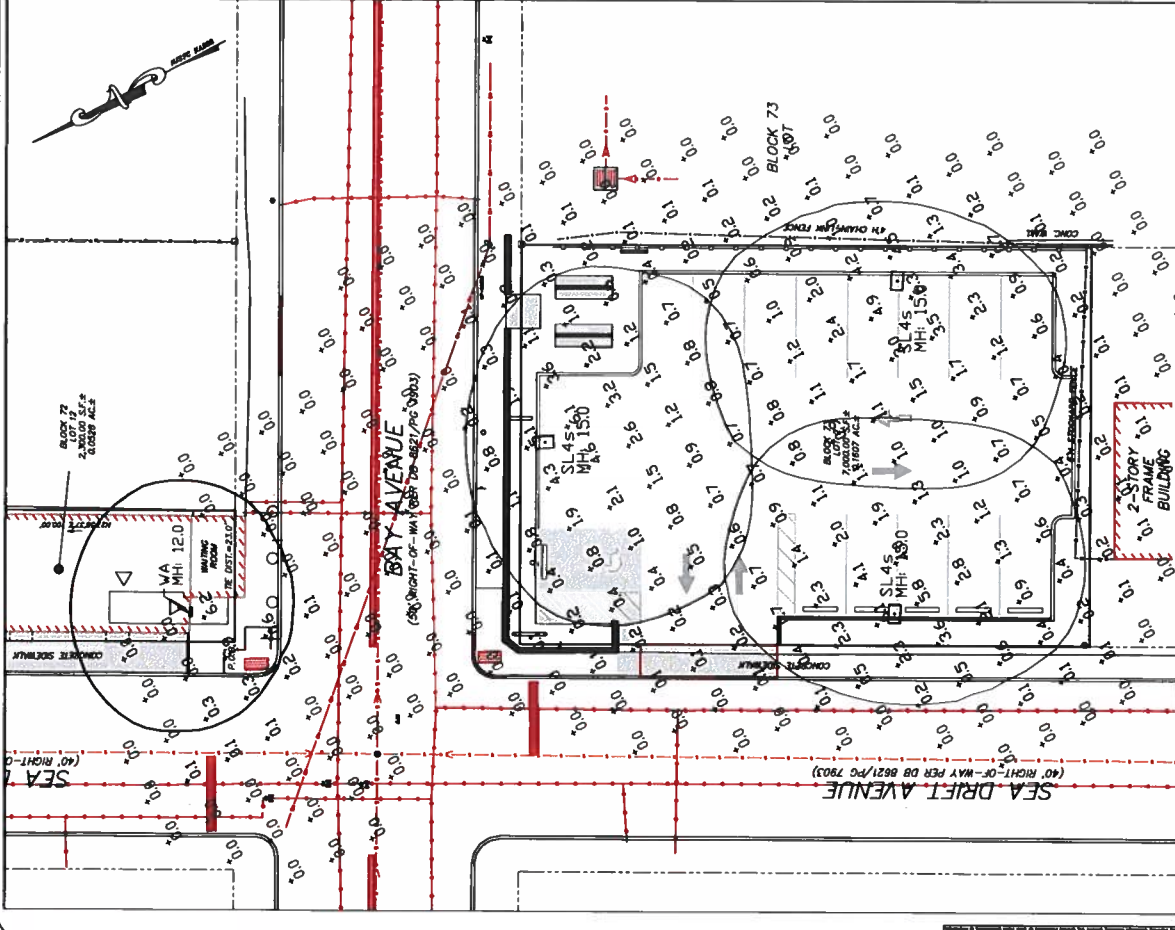

NOTES

- The calculated results of the lighting simulation represent a prediction of the lighting system performance. Actual results may vary from the anticipated performance and are subject to site conditions which are beyond the control of the lighting consultant.
- Calculations are based on a 10' mounting height for all fixtures.
- Calculations are based on a 10' mounting height for all fixtures.
- Calculations are based on a 10' mounting height for all fixtures.

LIGHTING NOTES

- ALL SITE LIGHTING SHALL BE PROVIDED BY THE ELECTRICAL CONTRACTOR.
- THE ELECTRICAL CONTRACTOR SHALL BE RESPONSIBLE FOR PROVIDING ALL NECESSARY CONDUITS FOR POWER, AND GROUNDING.
- THE ELECTRICAL CONTRACTOR SHALL BE RESPONSIBLE FOR INSTALLING ALL LIGHTING FIXTURES, AND LAMPS.
- THE ELECTRICAL CONTRACTOR SHALL BE RESPONSIBLE FOR PROVIDING ALL NECESSARY CONDUITS FOR POWER, AND GROUNDING.
- THE ELECTRICAL CONTRACTOR SHALL BE RESPONSIBLE FOR PROVIDING ALL NECESSARY CONDUITS FOR POWER, AND GROUNDING.
- THE ELECTRICAL CONTRACTOR SHALL BE RESPONSIBLE FOR PROVIDING ALL NECESSARY CONDUITS FOR POWER, AND GROUNDING.
- THE ELECTRICAL CONTRACTOR SHALL BE RESPONSIBLE FOR PROVIDING ALL NECESSARY CONDUITS FOR POWER, AND GROUNDING.
- THE ELECTRICAL CONTRACTOR SHALL BE RESPONSIBLE FOR PROVIDING ALL NECESSARY CONDUITS FOR POWER, AND GROUNDING.
- THE ELECTRICAL CONTRACTOR SHALL BE RESPONSIBLE FOR PROVIDING ALL NECESSARY CONDUITS FOR POWER, AND GROUNDING.
- THE ELECTRICAL CONTRACTOR SHALL BE RESPONSIBLE FOR PROVIDING ALL NECESSARY CONDUITS FOR POWER, AND GROUNDING.
- THE ELECTRICAL CONTRACTOR SHALL BE RESPONSIBLE FOR PROVIDING ALL NECESSARY CONDUITS FOR POWER, AND GROUNDING.
- THE ELECTRICAL CONTRACTOR SHALL BE RESPONSIBLE FOR PROVIDING ALL NECESSARY CONDUITS FOR POWER, AND GROUNDING.
- THE ELECTRICAL CONTRACTOR SHALL BE RESPONSIBLE FOR PROVIDING ALL NECESSARY CONDUITS FOR POWER, AND GROUNDING.
- THE ELECTRICAL CONTRACTOR SHALL BE RESPONSIBLE FOR PROVIDING ALL NECESSARY CONDUITS FOR POWER, AND GROUNDING.
- THE ELECTRICAL CONTRACTOR SHALL BE RESPONSIBLE FOR PROVIDING ALL NECESSARY CONDUITS FOR POWER, AND GROUNDING.

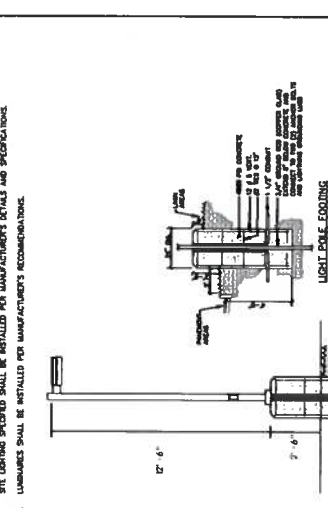

PRELIMINARY & FINAL MAJOR SITE PLAN
SEA GRABB MAL LIAISON
LIGHTING PLAN

11 South Main Street
 Portland, ME 04101
 207.633.1111
 www.eastpointeng.com

11/21/22
 11/21/22
 11/21/22

EAST POINT ENGINEERING, LLC
 11 South Main Street
 Portland, ME 04101
 207.633.1111
 www.eastpointeng.com

EMPIRE LIGHTING
 11 South Main Street
 Portland, ME 04101
 207.633.1111
 www.empirelighting.com

GRAPHIC SCALE
 1" = 10' 0" 1/4"

SOIL EROSION & SEDIMENT CONTROL NOTES

- 1. ALL SOIL EXPOSED TO WEATHERING SHALL BE PROTECTED WITH EROSION CONTROL MEASURES TO PREVENT SOIL LOSS AND TO PREVENT POLLUTION OF SURFACE WATER.
- 2. ALL SOIL EXPOSED TO WEATHERING SHALL BE PROTECTED WITH EROSION CONTROL MEASURES TO PREVENT SOIL LOSS AND TO PREVENT POLLUTION OF SURFACE WATER.
- 3. ALL SOIL EXPOSED TO WEATHERING SHALL BE PROTECTED WITH EROSION CONTROL MEASURES TO PREVENT SOIL LOSS AND TO PREVENT POLLUTION OF SURFACE WATER.

- 4. ALL SOIL EXPOSED TO WEATHERING SHALL BE PROTECTED WITH EROSION CONTROL MEASURES TO PREVENT SOIL LOSS AND TO PREVENT POLLUTION OF SURFACE WATER.
- 5. ALL SOIL EXPOSED TO WEATHERING SHALL BE PROTECTED WITH EROSION CONTROL MEASURES TO PREVENT SOIL LOSS AND TO PREVENT POLLUTION OF SURFACE WATER.
- 6. ALL SOIL EXPOSED TO WEATHERING SHALL BE PROTECTED WITH EROSION CONTROL MEASURES TO PREVENT SOIL LOSS AND TO PREVENT POLLUTION OF SURFACE WATER.

SEEDING SCHEDULE (PERMANENT & TEMPORARY) - ZONE 7A

- 1. SEEDING SHALL BE COMPLETED WITHIN THE SPECIFIED TIME FRAME.
- 2. SEEDING SHALL BE COMPLETED WITHIN THE SPECIFIED TIME FRAME.
- 3. SEEDING SHALL BE COMPLETED WITHIN THE SPECIFIED TIME FRAME.

- 4. SEEDING SHALL BE COMPLETED WITHIN THE SPECIFIED TIME FRAME.
- 5. SEEDING SHALL BE COMPLETED WITHIN THE SPECIFIED TIME FRAME.
- 6. SEEDING SHALL BE COMPLETED WITHIN THE SPECIFIED TIME FRAME.

STANDARDS FOR TOPSOILING

- 1. ALL SOIL EXPOSED TO WEATHERING SHALL BE PROTECTED WITH EROSION CONTROL MEASURES TO PREVENT SOIL LOSS AND TO PREVENT POLLUTION OF SURFACE WATER.
- 2. ALL SOIL EXPOSED TO WEATHERING SHALL BE PROTECTED WITH EROSION CONTROL MEASURES TO PREVENT SOIL LOSS AND TO PREVENT POLLUTION OF SURFACE WATER.
- 3. ALL SOIL EXPOSED TO WEATHERING SHALL BE PROTECTED WITH EROSION CONTROL MEASURES TO PREVENT SOIL LOSS AND TO PREVENT POLLUTION OF SURFACE WATER.

- 4. ALL SOIL EXPOSED TO WEATHERING SHALL BE PROTECTED WITH EROSION CONTROL MEASURES TO PREVENT SOIL LOSS AND TO PREVENT POLLUTION OF SURFACE WATER.
- 5. ALL SOIL EXPOSED TO WEATHERING SHALL BE PROTECTED WITH EROSION CONTROL MEASURES TO PREVENT SOIL LOSS AND TO PREVENT POLLUTION OF SURFACE WATER.
- 6. ALL SOIL EXPOSED TO WEATHERING SHALL BE PROTECTED WITH EROSION CONTROL MEASURES TO PREVENT SOIL LOSS AND TO PREVENT POLLUTION OF SURFACE WATER.

PERMANENT VEGETATIVE COVER (SECTION 4)

- 1. ALL SOIL EXPOSED TO WEATHERING SHALL BE PROTECTED WITH EROSION CONTROL MEASURES TO PREVENT SOIL LOSS AND TO PREVENT POLLUTION OF SURFACE WATER.
- 2. ALL SOIL EXPOSED TO WEATHERING SHALL BE PROTECTED WITH EROSION CONTROL MEASURES TO PREVENT SOIL LOSS AND TO PREVENT POLLUTION OF SURFACE WATER.
- 3. ALL SOIL EXPOSED TO WEATHERING SHALL BE PROTECTED WITH EROSION CONTROL MEASURES TO PREVENT SOIL LOSS AND TO PREVENT POLLUTION OF SURFACE WATER.

- 4. ALL SOIL EXPOSED TO WEATHERING SHALL BE PROTECTED WITH EROSION CONTROL MEASURES TO PREVENT SOIL LOSS AND TO PREVENT POLLUTION OF SURFACE WATER.
- 5. ALL SOIL EXPOSED TO WEATHERING SHALL BE PROTECTED WITH EROSION CONTROL MEASURES TO PREVENT SOIL LOSS AND TO PREVENT POLLUTION OF SURFACE WATER.
- 6. ALL SOIL EXPOSED TO WEATHERING SHALL BE PROTECTED WITH EROSION CONTROL MEASURES TO PREVENT SOIL LOSS AND TO PREVENT POLLUTION OF SURFACE WATER.

MULCH AND MULCH ANCHORING SPECIFICATIONS

- 1. ALL SOIL EXPOSED TO WEATHERING SHALL BE PROTECTED WITH EROSION CONTROL MEASURES TO PREVENT SOIL LOSS AND TO PREVENT POLLUTION OF SURFACE WATER.
- 2. ALL SOIL EXPOSED TO WEATHERING SHALL BE PROTECTED WITH EROSION CONTROL MEASURES TO PREVENT SOIL LOSS AND TO PREVENT POLLUTION OF SURFACE WATER.
- 3. ALL SOIL EXPOSED TO WEATHERING SHALL BE PROTECTED WITH EROSION CONTROL MEASURES TO PREVENT SOIL LOSS AND TO PREVENT POLLUTION OF SURFACE WATER.

- 4. ALL SOIL EXPOSED TO WEATHERING SHALL BE PROTECTED WITH EROSION CONTROL MEASURES TO PREVENT SOIL LOSS AND TO PREVENT POLLUTION OF SURFACE WATER.
- 5. ALL SOIL EXPOSED TO WEATHERING SHALL BE PROTECTED WITH EROSION CONTROL MEASURES TO PREVENT SOIL LOSS AND TO PREVENT POLLUTION OF SURFACE WATER.
- 6. ALL SOIL EXPOSED TO WEATHERING SHALL BE PROTECTED WITH EROSION CONTROL MEASURES TO PREVENT SOIL LOSS AND TO PREVENT POLLUTION OF SURFACE WATER.

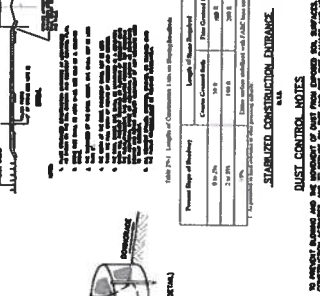
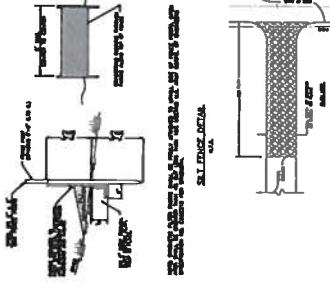
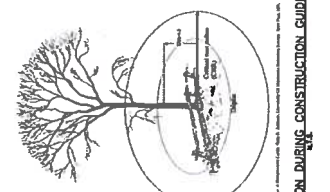
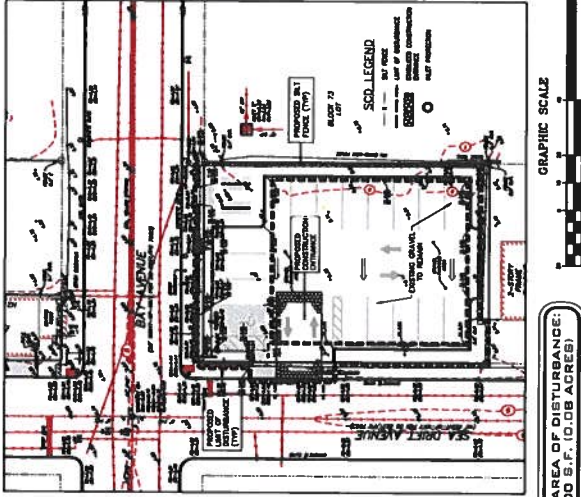

Table with 3 columns: Name of Device, Length (Minimum), Flow Control Rate. Includes rows for Stabilized Construction Entrance and Dust Control Device.

CONSTRUCTION SCHEDULE AND PROCEDURE FOR IMPLEMENTATION OF SOIL EROSION AND SEDIMENT CONTROL MEASURES

- 1. INSTALL SILT FENCE AND PROVIDE CONSTRUCTION DISTANCE.
- 2. CLEAR AND ESTABLISH NEARBY AREAS AS NECESSARY TO REMOVE.
- 3. MAINTAIN EXISTING VEGETATION AND CONSTRUCT LANDSCAPE WALL.
- 4. INSTALL LANDSCAPE WALL AND JAIL PERMANENT GRADE.
- 5. VERIFY VEGETATION COVER ON LOT.
- 6. REMOVE SILT FENCE AFTER ALL DISTURBED AREAS HAVE BEEN REVEGETATED.

Project information including: PRELIMINARY & FINAL MAJOR SITE PLAN, SOIL EROSION PLAN, EAST POINT ENGINEERING, INC., 11 South Main Street, Middletown, NJ 07940.



GRAPHIC SCALE: 1" = 50' (1" = 100' FOR DISTANCE). TOTAL AREA OF DISTURBANCE: 3,400 S.F. (0.08 ACRES).

DETAILS FOR PAVEMENT MARKINGS AND TRAFFIC SIGNS

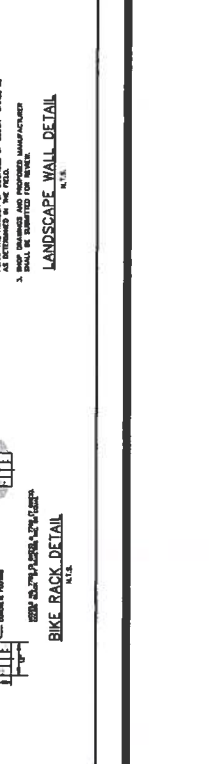
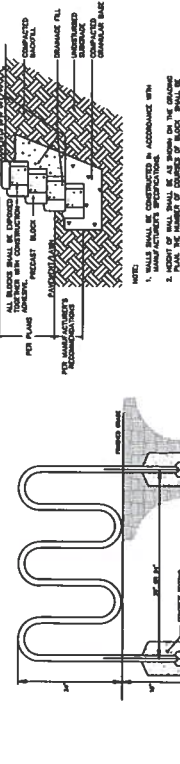
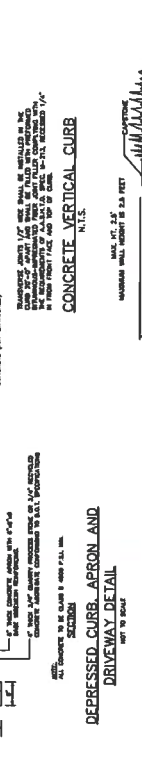
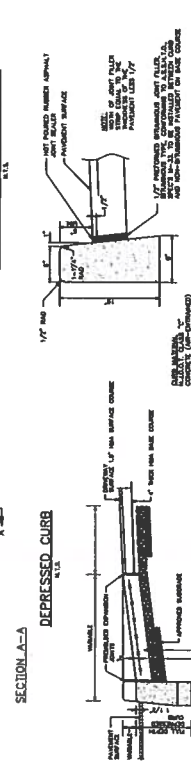
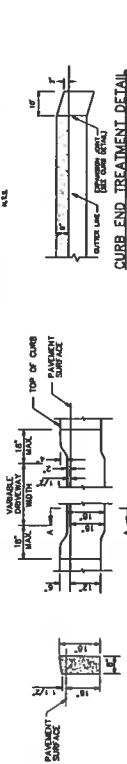
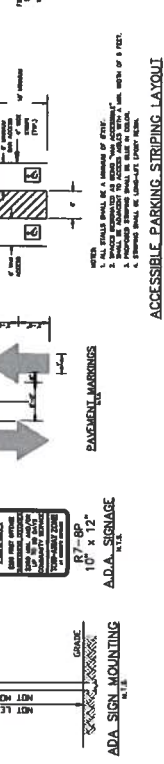
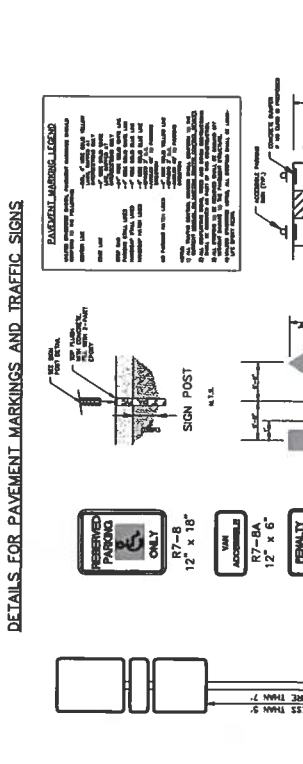
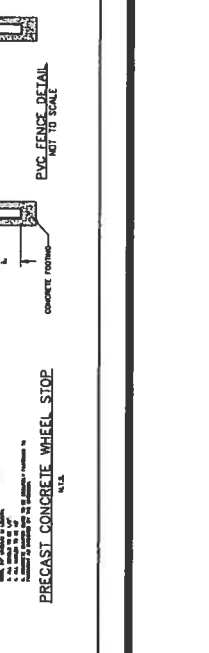
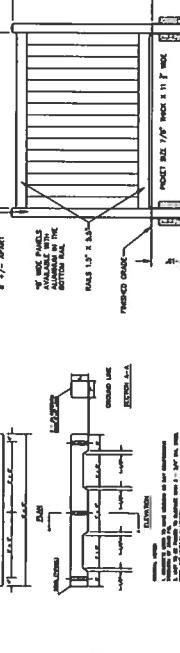
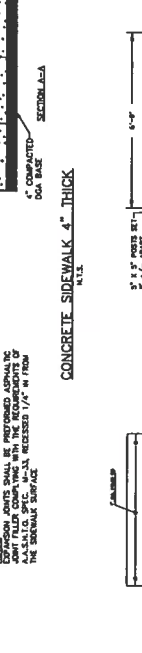
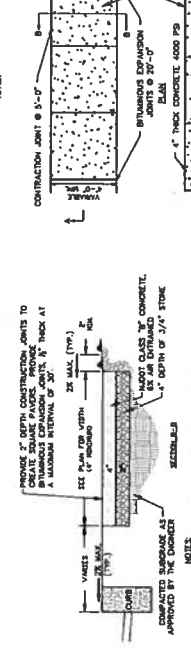
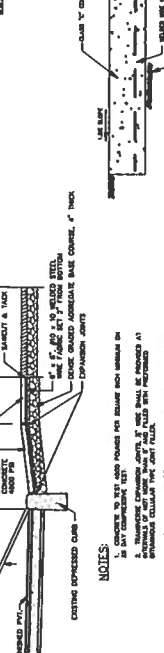
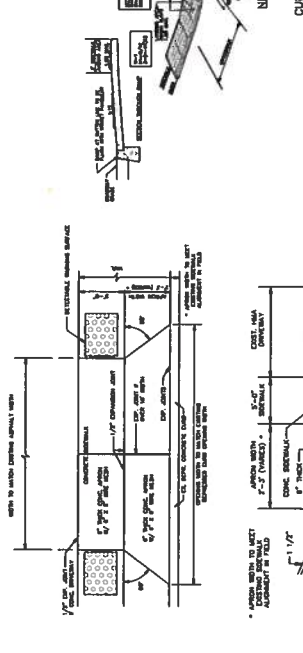
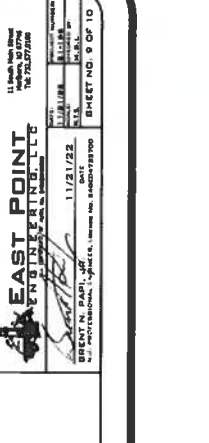
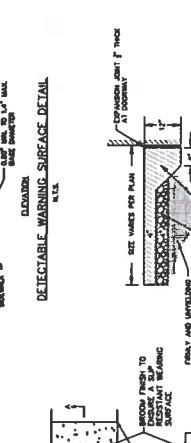
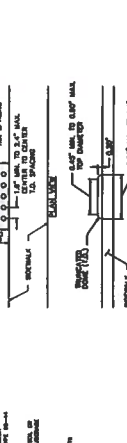
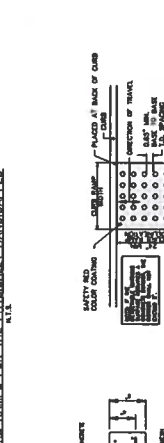
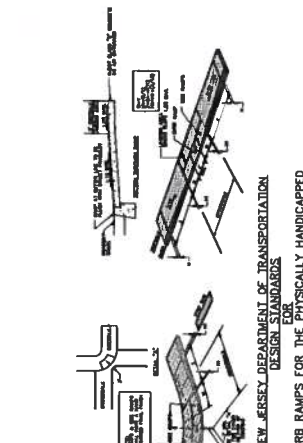
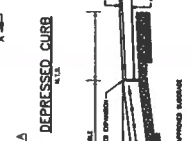
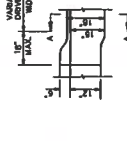
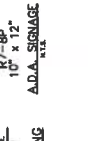
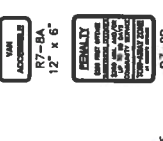
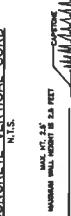
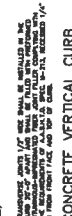
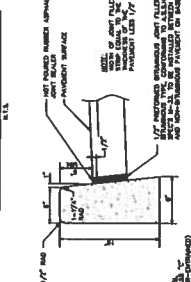
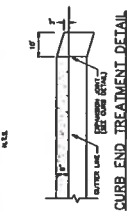
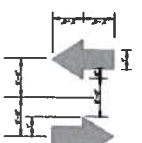
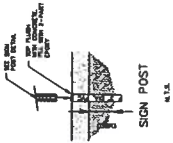
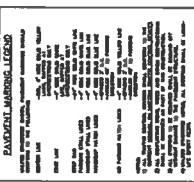

EAST POINT ENGINEERING & ARCHITECTURE, P.C.

11 South High Street
 BLDG. 79, LOT 7 & 8 BLDG. 79, LOT 8
 HONOLULU COUNTY, HAWAII, U.S.A.

11/21/22

SHEET NO. 9 OF 10

BUILDING WALL MOUNTED SIGN AT LOT 12, BLOCK 72



SIGN REQUIREMENTS — ORD. SEC. 21-102

BUILDING WALL MOUNTED SIGN — REPLACE EXISTING

MAX 15% OF FRONT BUILDING FACADE —

PERMITTED 460 SF x 15% = 69 SF — PROPOSED 28.2 SF

OFF-PREMISE GROUND MOUNTED SIGNS TO REPLACE EXISTING

MAX PERMITTED SIZE 24 SF

PARKING LOT SIGN = 20.8 SF (COMPLIES)

BOROUGH HISTORIC SIGN = 20.7 SF (COMPLIES)

OFF-PREMISE GROUND MOUNTED PARKING LOT SIGNS AT LOT 2, BLOCK 73

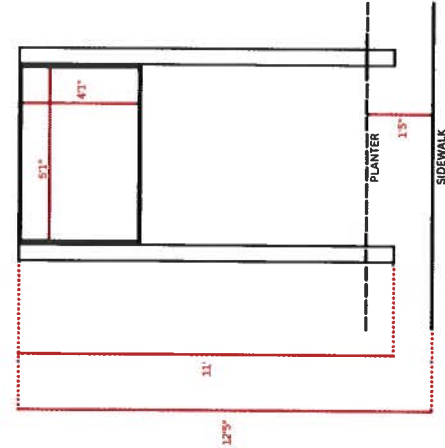

PARKING LOT SIGN

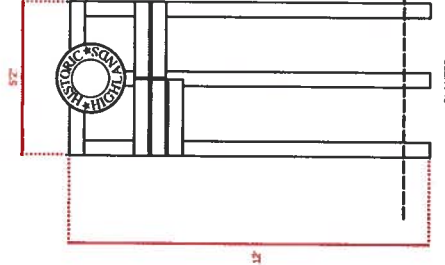

BOROUGH HISTORIC SIGN

PRELIMINARY & FINAL SIGN SITE PLAN	
SEA BIRDS NATURE	
SIGN PLAN	
BLOCK 72, LOT 8 & BLOCK 73, LOT 8	
MORRISON COUNTY, NEW JERSEY	
PLANNING DEPARTMENT, U.S.A.	
11 South High Street	
MORRISON COUNTY, NJ 07970	
DATE: 11/21/22	SHEET NO. 10 OF 10
SCALE: AS SHOWN	
BY: [Signature]	
CHECKED BY: [Signature]	
DESIGNED BY: [Signature]	



**BOROUGH OF HIGHLANDS
CANNABIS RETAILER LICENSE APPLICATION**

Date of initial submission _____

Date of approval by Borough Administrator _____

Applicant Business Name Sea Grass NJ LLC

Contact Information

Contact Name Stephen James Whelan

Phone No: 732-595-6700 E-Mail: idrwhelan@gmail.com

1. Business Entity Type

A. () Individual

List name, address and interest in business _____

B. () Partnership

List name, address and percentage of interest in Partnership _____

C. Corporation/LLC

List name, address and interest of all stockholders Nicholas Frangipane 51%

James Whelan 44%, Hannah LaRose 2%, Anthony Locascio 3%

2. Name as it will appear on the State License Sea Grass NJ LLC

3. N.J. Sales Tax Certificate of Authority No: 88-2250376

4. Trade names under which the business is to be conducted. Each and every trade name



must be listed and registered with the N.J. Secretary of State (if a corporation) or the Monmouth County Clerk (if a partnership or sole proprietor) _____

5. Business Marketing Information

- a. Business phone number _____
- b. Cell phone number of chief operating officer or executive of the business that will be the principal contact with the Borough 704-956-7807
- c. E-mail for business seagrassnj@gmail.com
- d. Website for business (if any) www.njseagrass.com

6. Business location where cannabis will be sold to consumers

Street address: 272 Bay Avenue

Block 72 Lot 12

Zone: Central Business District or () Highway Oriented Business Zone

7. Does the applicant have Conditional Use Approval from the Land Use Board? () Yes No

- a. If yes, attach copy of the Resolution of Approval.
- b. If no, provide the status of any application to the Land Use Board:
Application is submitted hearing date is January 12, 2023

8. Describe building and attach a picture Two story, CBD zoned on corner lot
Approximately 2,373sf retail level

9. Does the applicant own the building? () Yes No Property is under contract for purchase
Owner's Consent is attached to DPA

- a. If yes, attach a copy of the deed to the premises.
- b. If no, attach a copy of the lease agreement. It is the duty of the applicant to advise the landlord that if the license is issued to the applicant, it is not transferable.

10. Fully describe the business operation with an emphasis on:

- a. Will there be non-cannabis uses on site? No

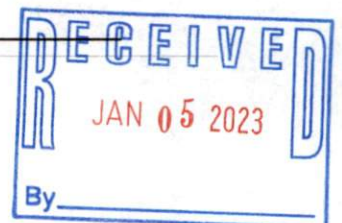

b. How will the operations remain separate from non-cannabis operations?
Under no circumstance shall another operation be permitted.

c. How will cannabis be secured? In a DEA cage inside of an access controlled vault.

11. Explain how the Highlands Police Department is to be advised of all security measures.

~~Highlands Police Department will have 24 hour access to our security~~

12. Provide the location of all surveillance cameras on site. _____
Please see attached security overlay

13. Will there be any special fire suppression equipment? No, unless the town requires

14. Will there be any exhausting of cannabis odors or particulate and how will they be eliminated?

~~Class 5 retailers do not typically have odor issues, but as a precaution we will.~~

15. Will there be business offices in addition to the retail operations? If so, describe their size and location. _____

~~Management offices and employee break area will be located on the second floor~~

16. Does the applicant have a New Jersey Conditional or Annual Cannabis Retailer License?

a. If yes, please provide your license number: RE000107

b. If no, please provide the documents attached to your New Jersey Conditional or Annual Cannabis Retailer License Application.

17. Provide a signed and notarized Affidavit in Support of Cannabis License Application.

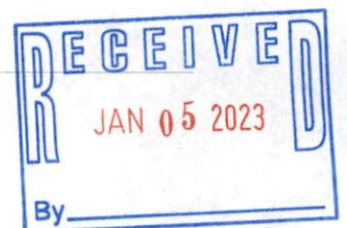

AFFIDAVIT IN SUPPORT OF CANNABIS LICENSE APPLICATION

STATE OF NEW JERSEY:

SS:

COUNTY OF MONMOUTH:

() Individual Applicant () Members of Partnership Applicant (✓) Pres./V.P.

Nicholas Frangipane of Sea Grass NJ LLC (name of business)

Consent(s) that the licensed premises and all portion of the building constituting the licensed premises, including all rooms, cellars, closets, out-buildings, passageways, vaults, yards, attics and every part of the structure of which the licensed premises are a part and all buildings used in connection therewith which are in his/her/their possession or under his/her/their control, may be inspected and searched without warrant at all hours by the N.J. Cannabis Regulatory, Enforcement, Assistance and Marketplace Modernization Act, his or her duly authorized deputies, inspectors or investigators and all other sworn law enforcement officers, and being duly sworn according to law, upon his/her/their oath(s), depose(s) and say(s) that he/she is (they are) the person(s) duly authorized to sign the application, that in stance of corporate ownership, the signator is authorized by corporate resolution to sign on behalf of the corporations; and that the contents of this application represent complete disclosure of the fact, and that the contents of this application are true.

[Signature]
Signature of Individual Agent/Sole Prop.

Sea Grass NJ LLC
Partnership Name

CORPORATIONS ONLY
Attestation by Corporate Secretary

[Signature]
Signature of Partner

Attest: Sea Grass NJ LLC
Corporate Name

[Signature]
Signature of Partner

Secretary signature: [Signature]

SWORN and SUBSCRIBED to before me this 5 day of Jan, 2023

[Signature]
Signature of Officer Administering Oath
Duly Authorized by Notary Public or Attorney at Law

MELISSA INDIVIGLIO
Notary Public, State of New Jersey
Commission # 50048224
My Commission Expires 10/24/2026

Melissa Indiviglio
Printed Name of Officer Administering Oath

10/24/26
Date of expiration of Commission

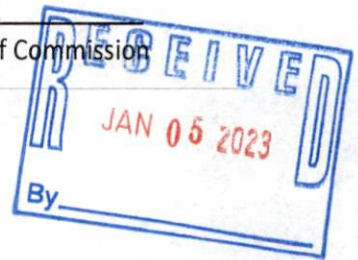



HGPB- R2000

January 16, 2023

Nancy Tran, Land Use Board Secretary
Borough of Highlands Land Use Board
42 Shore Drive
Highlands, New Jersey 07732

Via Email (ntran@highlandsborough.org)

**Re: Sea Grass NJ, LLC
272 Bay Avenue
Block 78, Lot 12 & Block 73, Lot 3
Central Business District (CBD) Zone
Redevelopment Zone C-RO-1
Minor Site Plan
& Conditional Use
First Completeness Review**

Dear Ms. Tran:

As requested, we have reviewed the above-referenced application in accordance with the Borough of Highlands Zoning and Land Use Regulations section entitled Part 3, Subdivision and Site Plan Review, Article VI, Application Procedure, and Article VIII, Plat and Plan Details, Section 21-58.E – Preliminary Site Plan.

The applicant submitted the following documents in support of this application:

1. Preliminary & Final Major Site Plans prepared by Brent N. Papi, Jr., PE, of East Point Engineering, LLC, dated November 21, 2022, consisting of ten (10) sheets.
2. Architectural Plans prepared Shissias Design + Development, dated December 2, 2022, consisting of three (3) sheets.
3. Land Use Board Application and supporting documents, dated December 6, 2022.
4. Zoning Permit Application and supporting documents, dated November 3, 2022.

The following information was reviewed for completeness purposes pursuant to Ordinance Section 21-58.D – Minor Site Plan:

Preliminary Site Plan (Minor): The preliminary site plan shall be drawn at a scale of not more than one hundred (100) feet to the inch and shall include such details as may be necessary to properly evaluate the application and determine compliance with this chapter. The site plan shall be drawn by a licensed New Jersey professional engineer and land surveyor and, where applicable to the proposed use or construction, the following information shall be clearly shown.

1. Date, name, location of site, name of owner, scale and reference meridian. **Provided.**
2. Area of the lot and all lot line dimensions and bearings. **Provided.**
3. The location of all existing watercourses, wooded areas, easements, rights-of-way, streets, roads, highways, rivers, buildings, structures and any other feature on the property and within seventy-five (75) feet of the property line. **Provided.**



Le: Nancy Tran, Land Use Board Secretary
Borough of Highlands Land Use Board

Re: Sea Grass NJ, LLC
272 Bay Avenue
Block 78, Lot 12 & Block 73, Lot 3
Central Business District (CBD) Zone
Redevelopment Zone C-RO-1
Minor Site Plan
& Conditional Use
First Completeness Review

4. Location, use and ground floor area of all existing and proposed buildings, with the building setback, side line and rear yard distance. **Provided.**
5. Elevations at the corners of all proposed buildings and paved areas and at property corners if new buildings or paved areas are proposed. **Provided. It should be noted that no new buildings are proposed as the applicant intends to renovate the existing building.**
6. The location and widths of existing and proposed streets servicing the site plan. **Provided.**
7. Specifications for and location of proposed surface paving and curbing. **Provided. It should be noted that the applicant proposes to retain the existing gravel parking lot and repair as needed.**
8. Location of all structures within seventy-five (75) feet of the property. **Provided.**
9. Location of off-street parking areas, with dimensions, showing proposed parking and loading spaces, with dimensions, width of proposed access drives and aisles and traffic circulation. **Provided.**
10. Storm water management and sanitary sewer reports, including proposed storm drainage and sanitary disposal facilities; specifically, the location, type and size of all existing and proposed catch basins, storm drainage facilities, utilities plus all required design data supporting the adequacy of the existing or proposed facilities to handle future storm flows. **Not applicable. No storm water management features are proposed.**
11. Existing and proposed contours of the property and for seventy-five (75) feet outside the property at one (1) foot intervals when new buildings or parking areas are proposed. Spot elevations for any development in a flood hazard area. **Provided.**
12. The location and treatment of proposed entrances and exits to the public rights-of-way, including the possible utilization of traffic signals, channelization, acceleration, and deceleration lanes, additional widths and any other devices necessary to traffic safety and/or convenience. **Provided.**
13. The location and identification of proposed open space, parks or other recreation areas. **Not applicable.**
14. The location and design of landscaping, buffer areas and screening areas showing size, species and spacing of trees and plants and treatment of unpaved areas. **Provided.**
15. The location of sidewalks, walkways, traffic islands and all other areas proposed to be devoted to pedestrian use. **Provided.**



**Le: Nancy Tran, Land Use Board Secretary
Borough of Highlands Land Use Board**

**Re: Sea Grass NJ, LLC
272 Bay Avenue
Block 78, Lot 12 & Block 73, Lot 3
Central Business District (CBD) Zone
Redevelopment Zone C-RO-1
Minor Site Plan
& Conditional Use
First Completeness Review**

- 16. The nature and location of public and private utilities, including maintenance and solid waste disposal, recycling and/or storage facilities. **Provided. A trash enclosure area is shown. The applicant intends to utilize the existing building and retain all utility connections.**
- 17. Specific location and design of traffic control devices, signs and lighting fixtures. The Board may require of the applicant expert testimony concerning the adequacy of proposed traffic control devices, signs and lighting fixtures. **Provided.**
- 18. Preliminary architectural plans for the proposed buildings or structures indicating typical floor plans, elevations, heights and general design or architectural styling. **Partially provided. The existing building's first floor elevation is approximately elevation 6.0. The existing building is located within flood zone AE-11. Therefore, the building renovation plans should be designed in accordance with FEMA standards and the Borough of Highlands Flood Damage Prevention Ordinance requirements. I defer to the Borough Floodplain Manager for further review.**
- 19. The present and past status and use and contemplated use of the property and all existing buildings on the property. A cleanup plan where such is necessary because of the past or present use of the site. **Provided.**
- 20. A soil erosion and sediment control plan is required. Said plan shall be submitted to the Soil Conservation District and approval of the application shall be conditioned upon certification of the soil erosion and sediment control plan by the District. **Provided.**
- 21. Soil Borings, when required by the Board Engineer. **Not required.**
- 22. Certification statement for the required municipal signatures, stating: **Provided.**
 - o Application No. _____ approved/disapproved by the Highlands Land Use Board as a Minor Site Plan on _____.

(date)

Chairman

Secretary
- 23. Certification statement for the County Planning Board approval / disapproval, if required. **Project fronts on a County Road, therefore approval or letter of no interest will ultimately be required from the County Planning Board.**
- 24. The Board may require any additional information which is reasonably necessary to ascertain compliance with the provisions of this chapter. **Informational.**



Le: Nancy Tran, Land Use Board Secretary
Borough of Highlands Land Use Board

Re: Sea Grass NJ, LLC
272 Bay Avenue
Block 78, Lot 12 & Block 73, Lot 3
Central Business District (CBD) Zone
Redevelopment Zone C-RO-1
Minor Site Plan
& Conditional Use
First Completeness Review

Per Section 21-97.M of the Ordinance, **one** cannabis retailer may be permitted in the Central Business District (CBD) Zone provided that applicable Article XI Design Standards are met together with any other requirements deemed necessary by the Land Use Board and applicable requirements of this chapter. **Prior to the public hearing the applicant shall provide a narrative outlining compliance with all Article XI Design Standards, and any applicable relief required/requested.**

In addition, the cannabis retailer shall not be located within 1,000 feet of any school. As discussed in the technical review meeting, a legal determination will be required as the proposed parking lot supporting the retail operation may be within 1,000 feet of the Highlands Elementary School property. If the Article XI Design Standards cannot be met, or the determination that the parking lot falls within 1,000 feet of the school (and counts as part of the cannabis retailer operation), then a d(3) conditional use variance may be required.

It should be noted that this project is located within the Central Business District (CBD) Zone. The property is also located within the CBD Redevelopment Overlay 1 (C-RO-1) Zone. The applicant may elect to prepare the application in accordance with either the CBD Zone or C-RO-1 Zone criteria, but one or the other shall be identified.

Adequate information has been provided in order to perform a technical review of the application. **The application shall therefore be deemed COMPLETE, pending confirmation from the Board Secretary that the balance of fees and escrows have been posted.**

We will also commence technical review upon same notification.

The application fee and escrow fee calculation letter will be provided under separate cover.

Should you have any questions or require any additional information, please call.

Very truly yours,

T&M ASSOCIATES

EDWARD W. HERRMAN, P.E., P.P., C.M.E., C.F.M.
LAND USE BOARD ENGINEER



**Le: Nancy Tran, Land Use Board Secretary
Borough of Highlands Land Use Board**

**Re: Sea Grass NJ, LLC
272 Bay Avenue
Block 78, Lot 12 & Block 73, Lot 3
Central Business District (CBD) Zone
Redevelopment Zone C-RO-1
Minor Site Plan
& Conditional Use
First Completeness Review**

EWH:KJO:KFJ

cc: Michael Muscillo, Borough Administrator (mmuscillo@highlandsborough.org)
Ron Cucchiaro, Esq., Land Use Board Attorney (RCucchiaro@Weiner.law)
Brian O'Callahan, Zoning Officer (bcallahan@middletownnj.org)
Sea Grass NJ, LLC, Applicant (idrwhelan@gmail.com)
Leonel Cervantes, Owner (leocervantes@hotmail.com)
John B. Anderson, III, Esq., Applicant's Attorney (janderson@fsfm-law.com)
Brent N. Papi, Jr., PE, Applicant's Engineer (bpapi@eastpointeng.com)
Shissias Design & Development, Applicant's Architect (kevin966@gmail.com)

\\tandmassociates.local\Public\Projects\HGPB\R2000\Correspondence\Tran_EWH_Sea Grass NJ LLC_First Completeness Review.docx



YOUR GOALS. OUR MISSION.

HGPB- R2000

January 16, 2023

Nancy Tran, Land Use Board Secretary
Borough of Highlands Land Use Board
42 Shore Drive
Highlands, New Jersey 07732

Via Email (ntran@highlandsborough.org)

**Re: Sea Grass NJ, LLC
272 Bay Avenue
Block 78, Lot 12 & Block 73, Lot 3
Central Business District (CBD) Zone
Redevelopment Zone C-RO-1
Minor Site Plan
& Conditional Use
Fee and Escrow Calculation**

Dear Ms. Tran:

As requested, we have reviewed the above-referenced application in accordance with the Borough of Highlands Land Use Regulations Part 6 - Fee Schedule.

The applicant submitted the following documents in support of this application:

1. Preliminary & Final Major Site Plans prepared by Brent N. Papi, Jr., PE, of East Point Engineering, LLC, dated November 21, 2022, consisting of ten (10) sheets.
2. Architectural Plans prepared Shissias Design + Development, dated December 2, 2022, consisting of three (3) sheets.
3. Land Use Board Application and supporting documents, dated December 6, 2022.
4. Zoning Permit Application and supporting documents, dated November 3, 2022.

Please note the following fee calculations:

- | | |
|----------------------------|-------------------|
| 1. Application fee: | \$1,600.00 |
| 2. Escrow fee: | \$3,200.00 |

Please note that the initial application deposits shall be deducted from the total fees shown.

Should you have any questions or require any additional information, please call.

Very truly yours,

T&M ASSOCIATES

EDWARD W. HERRMAN, P.E., P.P., C.M.E., C.F.M.
LAND USE BOARD ENGINEER

EWH:KJO:KFJ
Att.



Le: Nancy Tran, Land Use Board Secretary
Borough of Highlands Land Use Board

Re: Sea Grass NJ, LLC
272 Bay Avenue
Block 46, Lot 3
Central Business District (CBD) Zone
Minor Site Plan & Conditional Use
Fee Determination

cc: Michael Muscillo, Borough Administrator (mmuscillo@highlandsborough.org)
Ron Cucchiaro, Esq., Land Use Board Attorney (RCucchiaro@Weiner.law)
Brian O'Callahan, Zoning Officer (bcallahan@middletownnj.org)
Sea Grass NJ, LLC, Applicant (idrwhelan@gmail.com)
Leonel Cervantes, Owner (leocervantes@hotmail.com)
John B. Anderson, III, Esq., Applicant's Attorney (janderson@fsfm-law.com)
Brent N. Papi, Jr., PE, Applicant's Engineer (bpapi@eastpointeng.com)
Shissias Design & Development, Applicant's Architect (kevin966@gmail.com)

G:\Projects\HGPB\R2000\Correspondence\Tran_EWH_Sea Grass LLC_Fee Letter.docx



HGPB-R2000

DETERMINATION OF FEES*
Sea Grass, LLC - 272 Bay Avenue
Block 78, Lot 12 & Block 73, Lot 3

A. APPLICATION FEES (Ord. 21-107)

A. Variances

3. Nonresidential "c" (front yard setback)	1	EA	\$	250.00	\$	250.00
3. Nonresidential "c" (side yard setback per 21-91.A.4)	1	EA	\$	250.00	\$	250.00
3. Nonresidential "c" (lot coverage)	1	EA	\$	250.00	\$	250.00
4. Nonresidential "d3" (Section 21-97.M)	1	EA	\$	500.00	\$	500.00

C. Site Plans

1. Minor	1	LS	\$	100.00	\$	100.00
----------	---	----	----	--------	----	--------

E. Conditional Use Applications	1	EA	\$	250.00	\$	250.00
---------------------------------	---	----	----	--------	----	--------

B. ESCROW FEES (Ord. 21-108)

B. Escrow Deposits (twice Application Fee; Minimum \$750)	1	LS	\$	3,200.00	\$	3,200.00
---	---	----	----	----------	----	----------

Application fees subtotal \$ 1,600.00

Escrow fee subtotal \$ 3,200.00

Total \$ 4,800.00

*It should be noted that this application is being reviewed under the Central Business District (CBD) Zone criteria. The property is also located within the CBD Redevelopment Overlay 1 (C-RO-1) Zone. The applicant may elect to prepare the application in accordance with either the CBD Zone or C-RO-1 Zone criteria, but one or the other shall be identified.

KLEIN

TRAFFIC CONSULTING, LLC

156 Walker Road
West Orange, NJ 07052
973-985-3464
leekleintraffic@gmail.com

January 27, 2023

Nick Frangipane
Jim Whelan
Hannah LaRose
C/O Sea Grass NJ LLC
135 Maple Avenue
Red Bank, NJ 07701

VIA EMAIL: nick.frang@gmail.com

**Re: Traffic Engineering and Parking Evaluation
Proposed Cannabis Retailer
272 Bay Avenue, Highlands, Monmouth County, NJ**

Dear Mr. Frangipane:

This Traffic Engineering and Parking Evaluation (TEPE) report outlines our findings and recommendations for the proposed change of use from a 1,575 square foot restaurant and 1 apartment dwelling to a 1,525 square foot cannabis retailer and 848 square foot small office.

Familiarization with the Application

We have reviewed the architectural plan set dated 12/2/2022, prepared by Shissias Design + Development. We reviewed the site plan set dated 11/21/22, prepared by East Point Engineering, LLC. We referenced Google street view and aerial photographs to become familiar with the area.

Bay Avenue (County Route 8) is under the jurisdiction of Monmouth County. Bay Avenue is relatively flat, level, and straight near the subject site. Bay Avenue extends from S. Bay Avenue and Shore Drive in the east to Gravelly Point Road in the west. Bay Avenue runs parallel to and connects with Shore Drive at several intersecting streets. Near the subject site, Bay Avenue has one travel lane in each direction, with a posted speed limit of 25 MPH. Parking is permitted on both sides of the street with restrictions of “No Parking Friday between 7 AM and 8 AM” and “No Parking When Road is Snow Covered”. There are sidewalks on both sides of the street. There are curb ramps at the intersection of Bay Avenue with Sea Drift Avenue. In the Google street view images from September and October 2019, there are no painted crosswalks across Bay Avenue at the intersection of Bay Avenue with Sea Drift Avenue.

Sea Drift Avenue is a local roadway under the jurisdiction of Highlands Borough. Sea Drift Avenue extends from Shore Drive in the south to Marine Place in the north. Sea Drift Avenue is STOP-controlled at Bay Avenue with a northbound and southbound, single lane approach to Bay Avenue. Parking is permitted on both sides of the street. The statutory speed limit is 25 MPH. There are sidewalks on both sides of the street with no posted restrictions. In the Google street view images from September and October 2019, there are no painted crosswalks across Sea Drift Avenue at the intersection with Bay Avenue.

Mass Transportation

The number 834 bus line runs along Bay Avenue and stops at Washington Avenue and at Atlantic Street. The number 834 bus provides service between Highlands, Atlantic Highlands, Leonardo, New Monmouth, Middletown, and portions of Red Bank including the NJ Transit Rail Station. The available mass transportation provides a potential option for employees or customers to access the facility.

Trip Generation Calculations

According to the *Trip Generation Manual, 11th Edition* published by the Institute of Transportation Engineers (ITE), a High-Turnover (Sit-Down) Restaurant “*use consists of sit-down, full-service eating establishments with a typical duration of stay of 60 minutes or less. This type of restaurant is usually moderately priced, frequently belongs to a restaurant chain, and is commonly referred to as casual dining. Generally, these restaurants serve lunch and dinner; they may also be open for breakfast and are sometimes open 24 hours a day. These restaurants typically do not accept reservations. A patron commonly waits to be seated, is served by wait staff, orders from a menu, and pays after the meal. Some facilities offer carry-out for a small proportion of its customers. Some facilities within this land use may also contain a bar area for serving food and alcoholic drinks.*” Trip generation for the existing High-Turnover (Sit-Down) Restaurant was calculated using the current ITE *Trip Generation, 11th Edition* based on square footage and number of seats, as well as based on the “Peak of the Generator” and the “Peak of the Adjacent Street” (on a weekday the highest one hour of adjacent street traffic between 7-9 AM and 4-6 PM, and the highest one hour of street traffic a Saturday). We chose the larger of the trip generation values, “Peak of Generator” for 1,525 square feet.

According to the *Trip Generation Manual, 11th Edition* published by the ITE, Multifamily Housing (Low-Rise) *includes apartments, townhouses, and condominium located within the same building with at least three other dwelling units and that have two or three (floors) levels.* Trip generation for the existing 1-unit of multifamily housing (low-rise) was calculated using the current ITE *Trip Generation, 11th Edition*.

According to the *Trip Generation Manual, 11th Edition* published by the ITE, “*a Marijuana Dispensary is a stand-alone facility where cannabis is sold to patients or retail consumers in a legal manner.*” Trip generation for the proposed 1,525 square foot cannabis retailer was calculated using the current ITE *Trip Generation, 11th Edition* based on square footage for the

“Peak of the Generator” and the “Peak of the Adjacent Street”. We chose the larger of the trip generation values, “Peak of Generator” for 1,525 square feet.

According to the *Trip Generation Manual, 11th Edition* published by the ITE, a Small Office Building “is the same as a general office building (Land Use 710) but with less than or equal to 10,000 square feet of gross floor area. The building typically houses a single tenant. It is a location where affairs of a business, commercial or industrial organization, or professional person or firm are conducted.” Trip Generation for the proposed 848 square foot small office was calculated using the current ITE *Trip Generation, 11th Edition*.

We calculated the trip generation for the existing restaurant and apartment and for the proposed cannabis retailer and supporting office space. The attached Table 1 – Trip Generation Comparison and Summary tabulates the trip generation of the former restaurant and apartment and the proposed cannabis retailer. The existing restaurant and one apartment would generate 22 vehicle trips during the weekday AM peak hour, 26 vehicle trips during the weekday PM peak hour, and 18 vehicle trips during a Saturday peak hour. The proposed cannabis retailer and small office would generate 27 vehicle trips during the weekday AM peak hour, 39 vehicle trips during the weekday PM peak hour, and 46 vehicle trips during the Saturday peak hour.

Table 1 also shows the change in the number of weekday AM and PM peak hour trips and Saturday peak hour trips. The increase in the number of peak hour trips is 5 vehicle trips during weekday AM peak hour trips, 13 vehicle trips during the weekday PM peak hour, and 28 vehicle trips during the Saturday peak hour.

According to Transportation Impact Analysis for Site Development, published by the Institute of Transportation Engineers (ITE), an increase of less than 100 vehicle trips would not change the level of service of the local street network nor appreciably increase the volume-to-capacity ratio of an intersection approach. Also, NJDOT Access Management Code considers a significant increase in trips greater than 100 peak hour trips AND greater than a 10 percent increase in previously anticipated daily trips. Therefore, the proposed development is not anticipated to significantly impact the operations of the local streets. Based on industry guidelines from the Institute of Transportation Engineers (ITE) as well as the NJDOT Access Code, the new vehicle trips generated by the proposed change of use from a restaurant and apartment to a cannabis retailer would not have a significant impact on traffic operations. Furthermore, the traffic generated to and from the property’s parking lot would be distributed on Sea Drift Avenue to Bay Avenue and to Shore Drive, further lessening any potential traffic impacts.

We were able to research the NJDOT website and find traffic volumes on Bay Avenue between Sea Drift Avenue and Atlantic Street from Monday, June 25 to Thursday, June 28, 2018. These traffic volumes show the two-way traffic volumes on Bay Avenue as between 250 and 325

vehicles per hour during the AM peak period and between 375 and 450 vehicles per hour during the PM peak hour. If all the trips generated by the proposed cannabis retailer were to use Bay Avenue only, those trips would be about 16 percent of the total traffic along Bay Avenue. The restaurant and apartment traffic were about 9 percent of the total traffic volumes on Bay Avenue. But again, the traffic to and from the parking lot would be distributed to Bay Avenue and Shore Drive, further lessening the traffic impacts generated by the property. Typically, traffic volumes can vary from day to day by more than 10 percent. The traffic volumes collected from the NJDOT website show that the traffic volumes during the AM and PM peak period fluctuate by 10 percent to 15 percent between Tuesday, June 26, 2018, and Wednesday, June 27, 2018. Therefore, the increase in traffic volumes generated by the change of use from a restaurant and apartment to a cannabis retailer would be insignificant and not noticed by drivers in the area.

Parking Requirements

The total space within the building is 2,373 square feet. Based on the local parking requirement of 1 parking space per 600 square feet pursuant to the Borough's Ordinance 21-65.14.D(7a), the 2,373 square feet of business/commercial/retail store use would require 4 parking spaces. The parking lot provides 17 parking spaces, including 1 ADA parking space, more than 4 times the required parking.

Conclusion

Based on the number of trips that would be generated during the weekday AM and PM peak hours being less than the industry standard of 100 peak hour trips, and the fact that there are two main roadways, Bay Avenue and Shore Drive, to distribute the traffic generated by the proposed cannabis retailer, the traffic generated by the proposed cannabis retailer would not have a significant impact on the operation of the surrounding streets.

Using the local Ordinance requirements for parking for the currently proposed cannabis retailer, the total parking requirement is 4 parking spaces, whereas 17 parking spaces are provided. The proposed parking supply of 17 parking spaces is over 4 times more than required by the local Ordinance.

Please contact me if you have any questions.

Sincerely,



Lee D. Klein, P.E., PTOE
NJPE 24GE03710400
PTOE Certification 1627

C:\Users\Leekl\Documents\WORK\Highlands-SeaGrass\Klein_TEPE_272BayAvHighlands_013023.docx

**Table 1 - Trip Generation Comparison and Summary
272 Bay Avenue, Highlands, Monmouth County, NJ**

CODE	LAND USE	AMOUNT	WEEKDAY				SATURDAY		
			AM PEAK HOUR		PM PEAK HOUR		PEAK HOUR		
			IN	OUT	TOTAL	IN	OUT	IN	OUT
EXISTING									
932	H-T (Sit-Down) Restaurant (Peak of Generator)	1,525 SF	12	9	21	13	12	8	17
932	H-T (Sit-Down) Restaurant (Street Peak)	1,525 SF	8	7	15	8	5	8	17
932	H-T (Sit-Down) Restaurant (Peak of Generator)	30 Seats	11	7	18	12	11	8	16
932	H-T (Sit-Down) Restaurant (Street Peak)	30 Seats	7	6	14	7	5	8	16
220	Low-Rise Apartment (Average Rate)	1 units	0	1	1	1	0	1	1
TOTAL EXISTING TRIP GENERATION			12	10	22	14	12	9	18
PROPOSED									
882	Marijuana Dispensary (Peak of Generator)	1,525 SF	14	12	26	18	19	22	44
882	Marijuana Dispensary (Street Peak)	1,525 SF	8	8	16	14	15	22	44
712	Small Office Building (General Urban/Suburban)	848 SF	1	0	1	1	1	1	2
TOTAL EXISTING TRIP GENERATION			15	12	27	19	20	24	46
CHANGE IN NUMBER OF VEHICLE TRIPS			3	2	5	5	8	14	28

SOURCE: *Trip Generation, 11th Edition*, published by the Institute of Transportation Engineers (ITE)

NOTE: ## - Indicates an INCREASE in the number of trips from existing to proposed

Google Maps

272 Bay Ave

LOCATION MAP

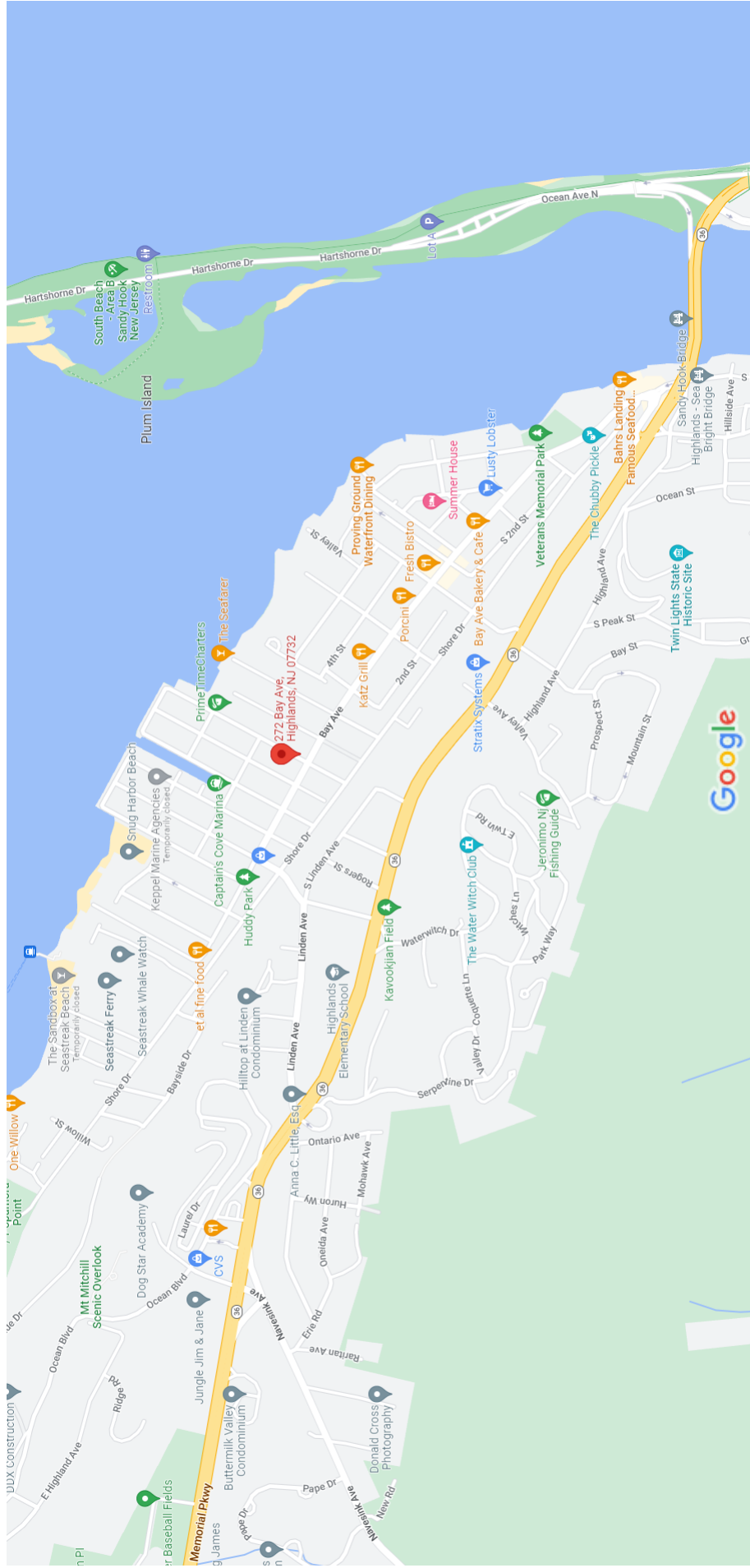

Map data ©2023 Google 500 ft

PROJECT DESCRIPTION

PROJECT: SEA GRASS NJ DISPENSARY
 INTERIOR RENOVATIONS / COMMERCIAL FIT-OUT

272 BAY AVENUE
 BOROUGH OF HIGHLANDS, NEW JERSEY
 MONMOUTH COUNTY
 BLOCK 72 - LOT 12

PROPOSED USE: COMMERCIAL (B & M OCCUPANCY)

PROJECT DESCRIPTION: INTERIOR RENOVATION OF EXISTING FIRST FLOOR RESTAURANT INTO MERCHANTILE SPACE AND INTERIOR RENOVATION OF EXISTING SECOND FLOOR RESIDENTIAL APARTMENT INTO A TYPICAL USE (NON-HIGH-CONCENTRATION) OFFICE SPACE TO ACCOMPANY FIRST FLOOR BUSINESS.

Sea Grass NJ

Interior Renovations / Commercial Fit-Out
 272 Bay Avenue, Borough of Highlands, NJ 07732
 Block 72, Lot 12

DRAWING LIST

- A1 COVER SHEET & DEMO
- A2 PROPOSED FLOOR PLANS
- A3 EXTERIOR ELEVATIONS

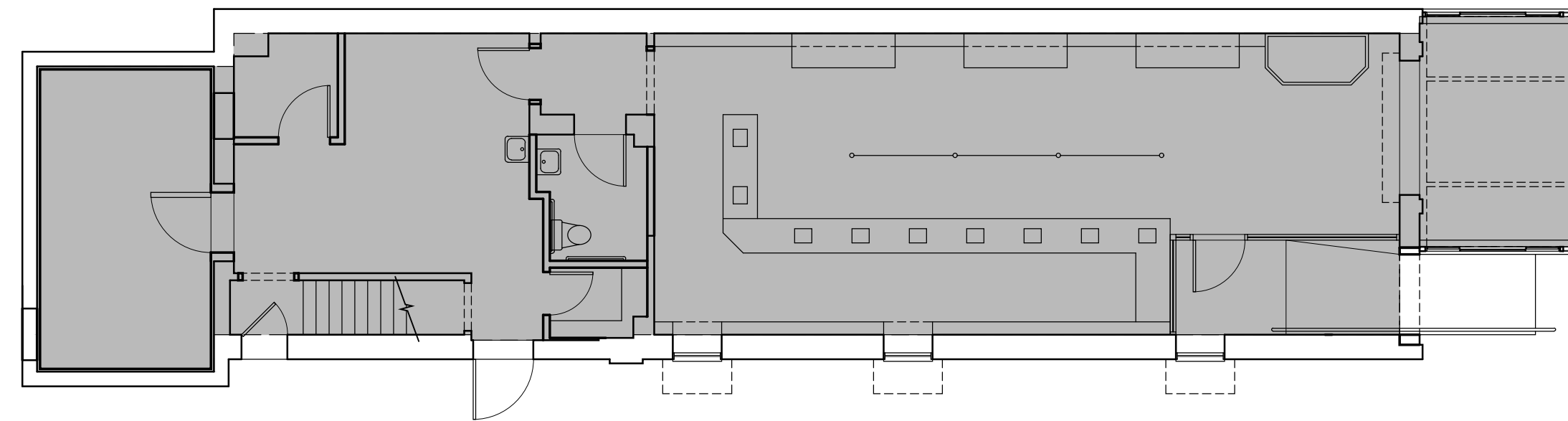

3 1ST FLOOR GROSS FLOOR AREA DIAGRAM
 A2 1/8" = 1'-0"

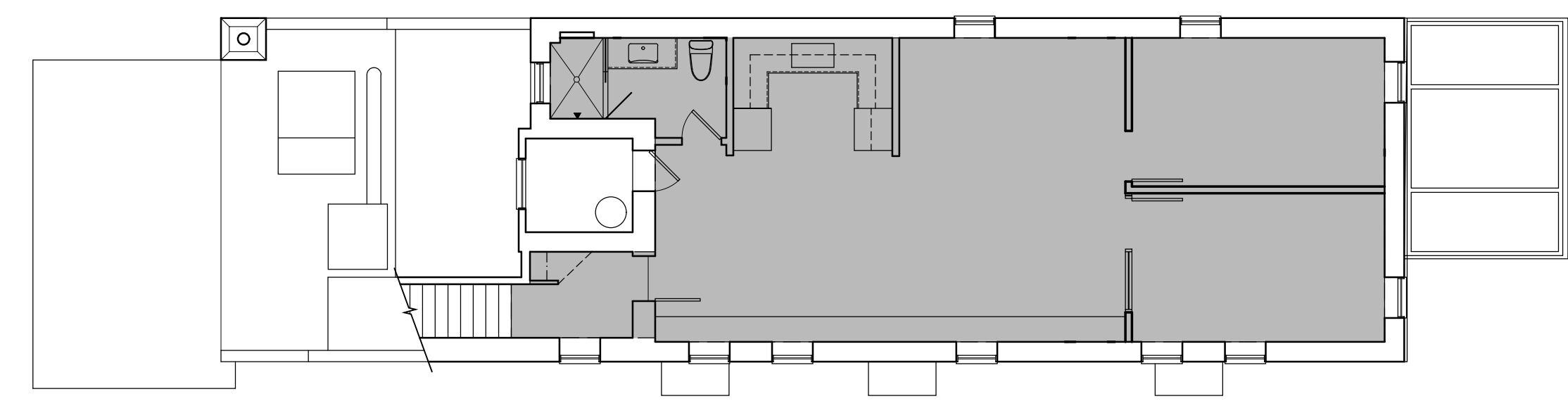

4 2ND FLOOR GROSS FLOOR AREA DIAGRAM
 A2 1/8" = 1'-0"

1ST FL.	1,525 SF
2ND FL.	848 SF
TOTAL G.F.A.	2,373 SF

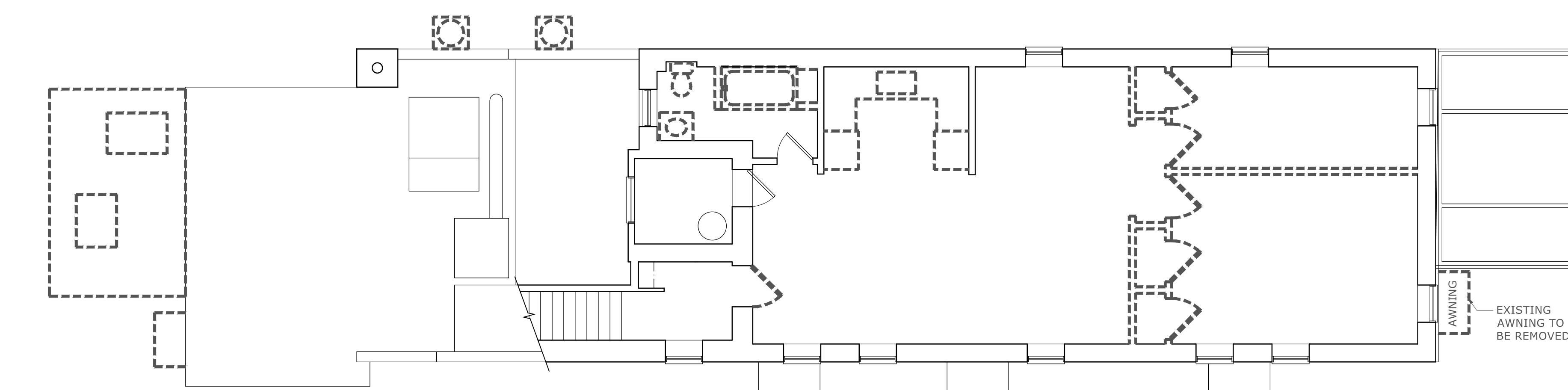

2 SECOND FLOOR DEMOLITION PLAN
 A2 3/16" = 1'-0"

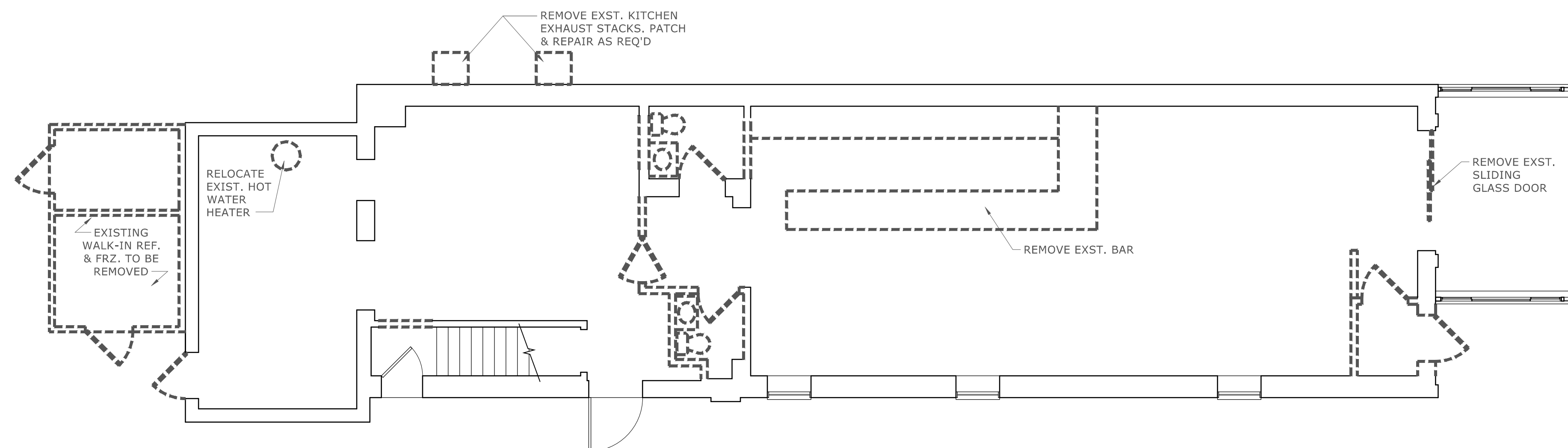

1 FIRST FLOOR DEMOLITION PLAN
 A2 3/16" = 1'-0"

DEMOLITION LEGEND

- EXISTING WALL TO REMAIN
- EXISTING WALL TO BE DEMOLISHED
- EXISTING DOOR TO REMAIN
- EXISTING DOOR TO BE DEMOLISHED

DEMOLITION NOTES

VERIFY ALL EXISTING CONDITIONS IN FIELD PRIOR TO DEMOLITION. CONTRACTOR TO NOTIFY ARCHITECT IF EXISTING CONDITIONS VARY FROM DRAWINGS.

CONFIRM EXISTING STRUCTURE WITH ARCHITECT

CONTRACTOR TO PROVIDE TEMPORARY SUPPORT FOR ALL STRUCTURAL BEARING MEMBERS PRIOR TO ANY DEMOLITION.

CONTRACTOR TO REMOVE & CAP ALL EXISTING ELECTRICAL & PLUMBING AS REQUIRED FOR DEMOLITION AND NEW WORK.

PATCH AND REPAIR EXISTING TO MATCH ADJACENT AS NECESSARY.

EXISTING WINDOWS TO REMAIN UNLESS NOTED OTHERWISE.

CONTRACTOR TO CONDUCT A WALK-THROUGH WITH THE OWNER PRIOR TO COMMENCING DEMOLITION TO CONFIRM WHAT IS TO BE DEMOLISHED, REMOVED, SALVAGED, ETC.

SEE PROPOSED PLANS AND ELEVATIONS TO HELP DETERMINE THE EXTENT OF DEMOLITION THAT IS REQUIRED.

SHISSIAS
 DESIGN + DEVELOPMENT
 Alex P. Shissias, P.A., R.A.
 Architect
 NJ Landscape Architect # 21A50017900
 966.448.0665
 www.shissias.com
 ashissias@gmail.com
 27 1st St. Rumson, NJ 07730

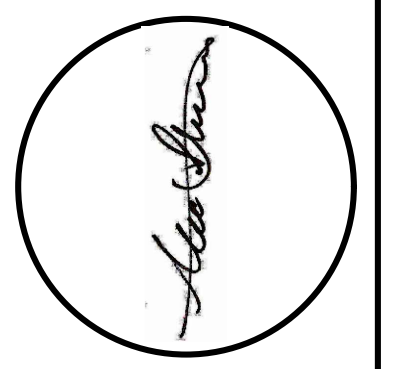
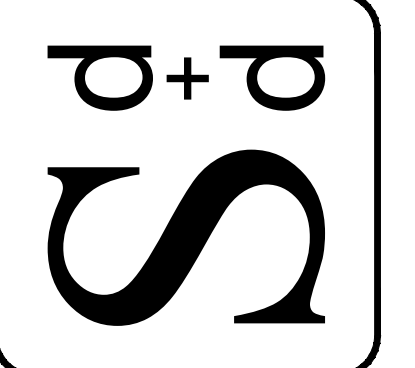

NOT FOR CONSTRUCTION UNLESS SIGNED & SEALED BY ARCHITECT & APPROVED BY ALL AGENCIES HAVING JURISDICTION.

USE OF THIS DESIGN OR DISSEMINATION IS PROHIBITED WITHOUT PRIOR WRITTEN CONSENT OF SHISSIAS DESIGN AND DEVELOPMENT. ALL COPYRIGHT LAWS ARE RESERVED. DRAWINGS ARE NOT INTENDED FOR PROTOTYPICAL USE. SHISSIAS DESIGN AND DEVELOPMENT © 2022.

ISSUE	REVISIONS

Sea Grass NJ
 Interior Renovations / Commercial Fit-Out
 272 Bay Avenue, Borough of Highlands, NJ 07732
 Block 72, Lot 12

Proj. No: 2022.81
 Issued For: Board Approval
 Date: 1 / 25 / 2023

COVER SHEET & DEMO

A1

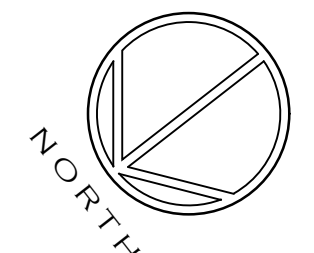

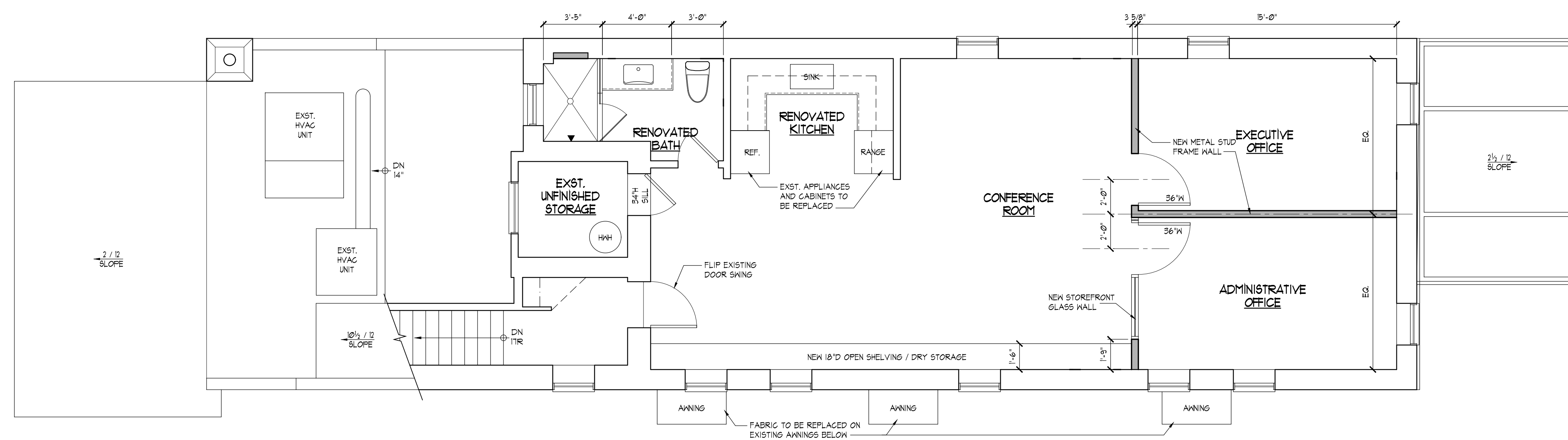

2 SECOND FLOOR PLAN
 A3 1/4" = 1'-0"

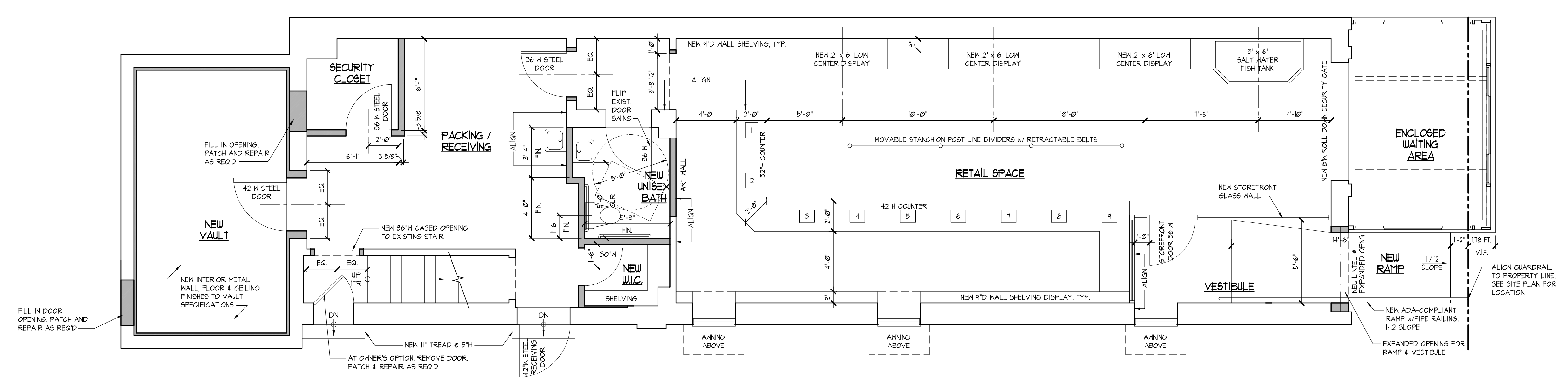

1 FIRST FLOOR PLAN
 A3 1/4" = 1'-0"

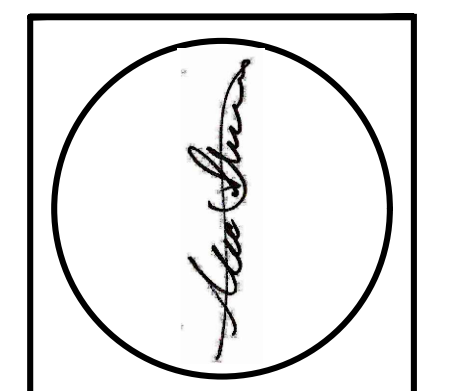
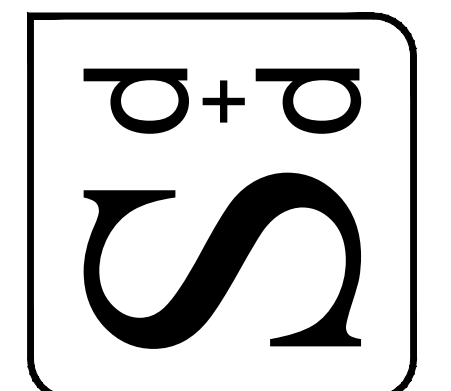
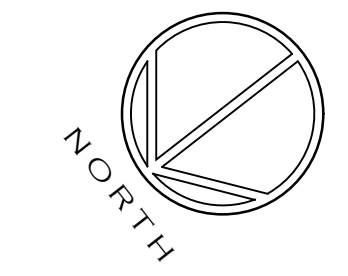

NOT FOR CONSTRUCTION UNLESS SIGNED & SEALED BY ARCHITECT & APPROVED BY ALL AGENCIES HAVING JURISDICTION.
 USE OF THIS DESIGN OR DISSEMINATION IS PROHIBITED WITHOUT PRIOR WRITTEN CONSENT OF SHISSIAS DESIGN AND DEVELOPMENT. ALL COPYRIGHT LAWS ARE RESERVED. DRAWINGS ARE NOT INTENDED FOR PROTOTYPICAL USE. SHISSIAS DESIGN AND DEVELOPMENT © 2022.

ISSUE	REVISIONS

Proj. No: 2022.81
 Issued For: Board Approval
 Date: 1 / 25 / 2023

PROPOSED FLOOR PLANS

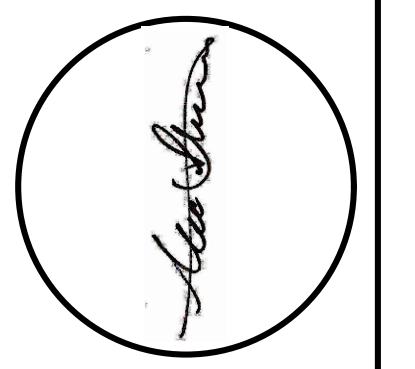
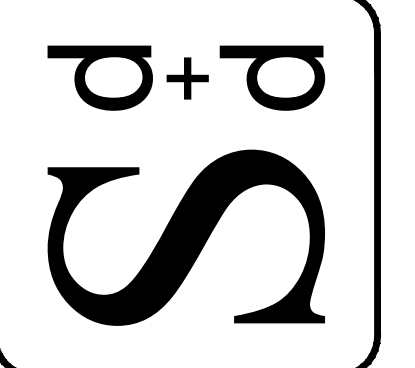

NOT FOR CONSTRUCTION UNLESS SIGNED & SEALED BY ARCHITECT & APPROVED BY ALL AGENCIES HAVING JURISDICTION.
 USE OF THIS DESIGN OR DISSEMINATION IS PROHIBITED WITHOUT PRIOR WRITTEN CONSENT OF SHISSIAS DESIGN AND DEVELOPMENT. ALL COPYRIGHT LAWS ARE RESERVED. DRAWINGS ARE NOT INTENDED FOR PROTOTYPICAL USE. SHISSIAS DESIGN AND DEVELOPMENT © 2022.

ISSUE	REVISIONS

Proj. No: 2022.81
 Issued For: Board Approval
 Date: 1 / 25 / 2023

EXTERIOR ELEVATIONS

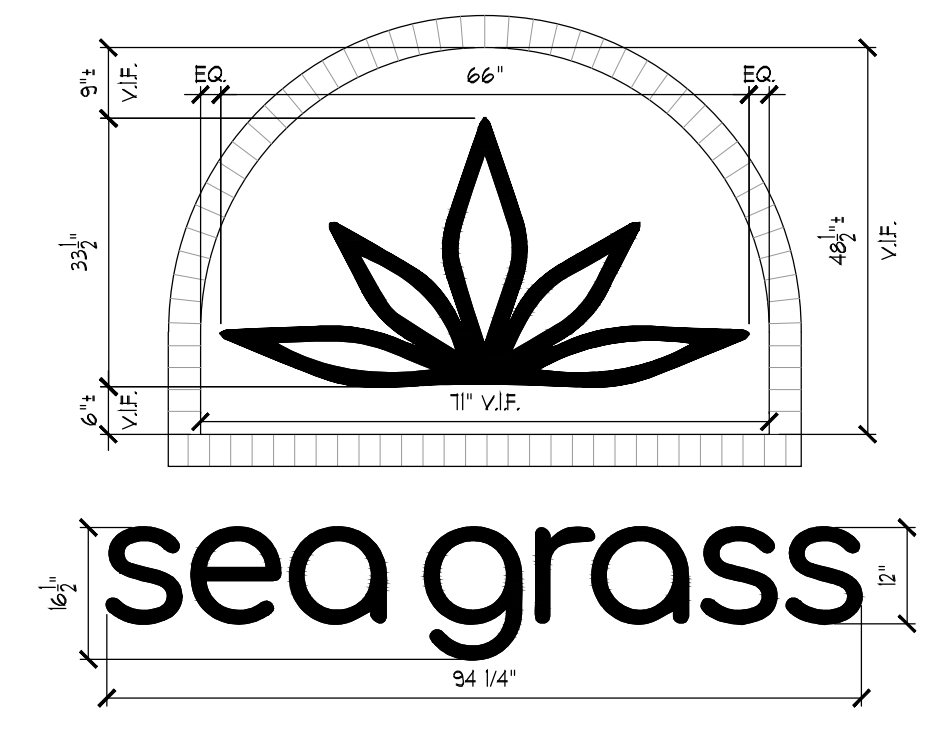

5
 A4 1/2" = 1'-0"



2
 A4 1/4" = 1'-0"

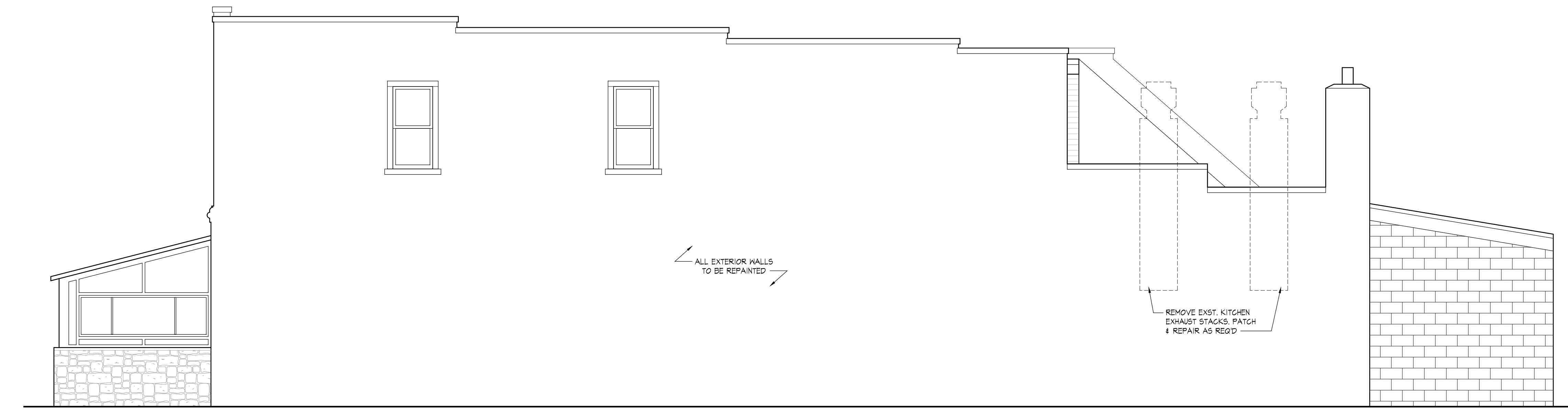

4
 A4 1/4" = 1'-0"



1
 A4 1/4" = 1'-0"

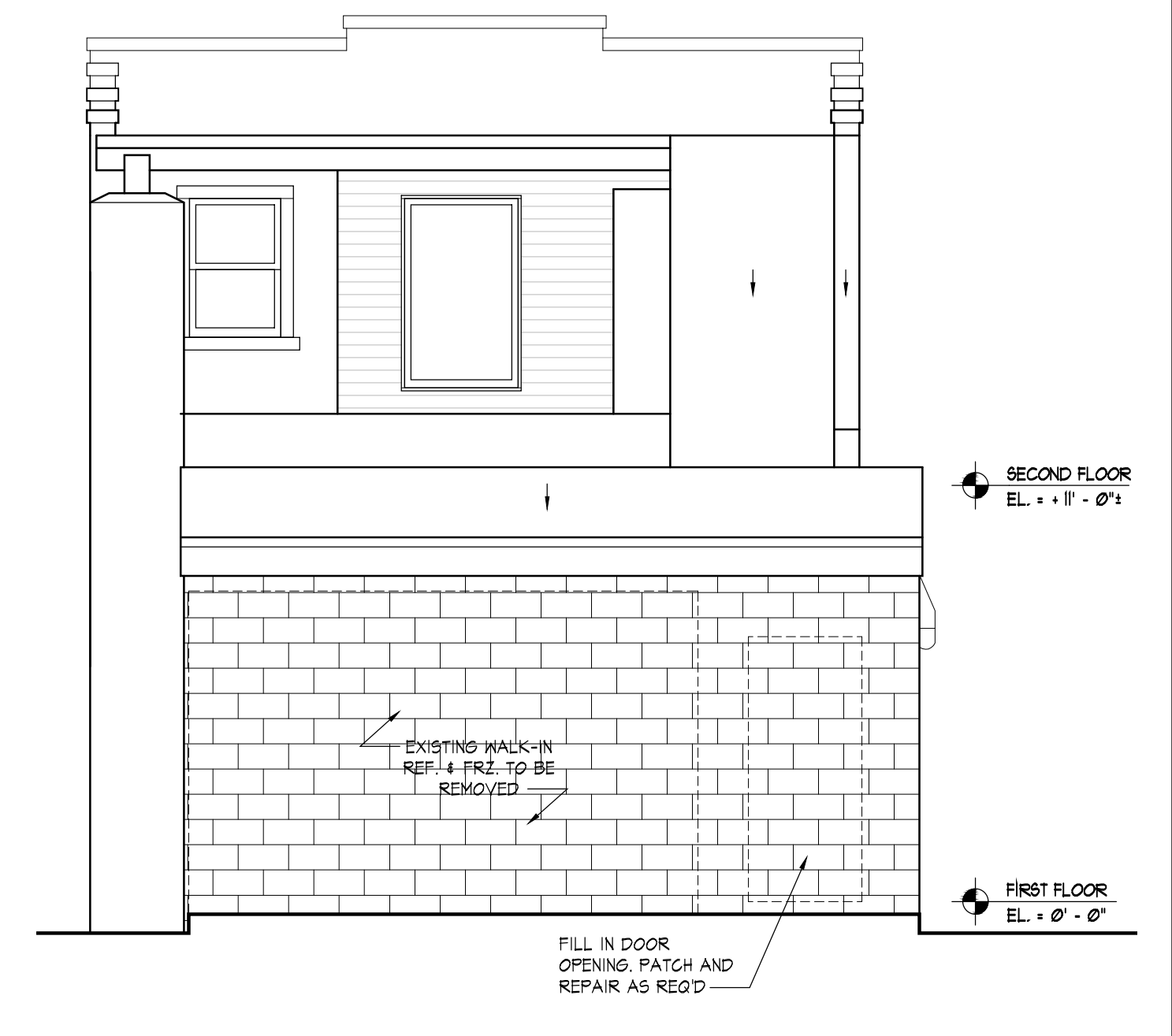

3
 A4 1/4" = 1'-0"

KLEIN

TRAFFIC CONSULTING, LLC

156 Walker Road
West Orange, NJ 07052
973-985-3464
leekleintraffic@gmail.com

January 27, 2023

Nick Frangipane
Jim Whelan
Hannah LaRose
C/O Sea Grass NJ LLC
135 Maple Avenue
Red Bank, NJ 07701

VIA EMAIL: nick.frang@gmail.com

**Re: Traffic Engineering and Parking Evaluation
Proposed Cannabis Retailer
272 Bay Avenue, Highlands, Monmouth County, NJ**

Dear Mr. Frangipane:

This Traffic Engineering and Parking Evaluation (TEPE) report outlines our findings and recommendations for the proposed change of use from a 1,575 square foot restaurant and 1 apartment dwelling to a 1,525 square foot cannabis retailer and 848 square foot small office.

Familiarization with the Application

We have reviewed the architectural plan set dated 12/2/2022, prepared by Shissias Design + Development. We reviewed the site plan set dated 11/21/22, prepared by East Point Engineering, LLC. We referenced Google street view and aerial photographs to become familiar with the area.

Bay Avenue (County Route 8) is under the jurisdiction of Monmouth County. Bay Avenue is relatively flat, level, and straight near the subject site. Bay Avenue extends from S. Bay Avenue and Shore Drive in the east to Gravelly Point Road in the west. Bay Avenue runs parallel to and connects with Shore Drive at several intersecting streets. Near the subject site, Bay Avenue has one travel lane in each direction, with a posted speed limit of 25 MPH. Parking is permitted on both sides of the street with restrictions of “No Parking Friday between 7 AM and 8 AM” and “No Parking When Road is Snow Covered”. There are sidewalks on both sides of the street. There are curb ramps at the intersection of Bay Avenue with Sea Drift Avenue. In the Google street view images from September and October 2019, there are no painted crosswalks across Bay Avenue at the intersection of Bay Avenue with Sea Drift Avenue.

Sea Drift Avenue is a local roadway under the jurisdiction of Highlands Borough. Sea Drift Avenue extends from Shore Drive in the south to Marine Place in the north. Sea Drift Avenue is STOP-controlled at Bay Avenue with a northbound and southbound, single lane approach to Bay Avenue. Parking is permitted on both sides of the street. The statutory speed limit is 25 MPH. There are sidewalks on both sides of the street with no posted restrictions. In the Google street view images from September and October 2019, there are no painted crosswalks across Sea Drift Avenue at the intersection with Bay Avenue.

Mass Transportation

The number 834 bus line runs along Bay Avenue and stops at Washington Avenue and at Atlantic Street. The number 834 bus provides service between Highlands, Atlantic Highlands, Leonardo, New Monmouth, Middletown, and portions of Red Bank including the NJ Transit Rail Station. The available mass transportation provides a potential option for employees or customers to access the facility.

Trip Generation Calculations

According to the *Trip Generation Manual, 11th Edition* published by the Institute of Transportation Engineers (ITE), a High-Turnover (Sit-Down) Restaurant “*use consists of sit-down, full-service eating establishments with a typical duration of stay of 60 minutes or less. This type of restaurant is usually moderately priced, frequently belongs to a restaurant chain, and is commonly referred to as casual dining. Generally, these restaurants serve lunch and dinner; they may also be open for breakfast and are sometimes open 24 hours a day. These restaurants typically do not accept reservations. A patron commonly waits to be seated, is served by wait staff, orders from a menu, and pays after the meal. Some facilities offer carry-out for a small proportion of its customers. Some facilities within this land use may also contain a bar area for serving food and alcoholic drinks.*” Trip generation for the existing High-Turnover (Sit-Down) Restaurant was calculated using the current ITE *Trip Generation, 11th Edition* based on square footage and number of seats, as well as based on the “Peak of the Generator” and the “Peak of the Adjacent Street” (on a weekday the highest one hour of adjacent street traffic between 7-9 AM and 4-6 PM, and the highest one hour of street traffic a Saturday). We chose the larger of the trip generation values, “Peak of Generator” for 1,525 square feet.

According to the *Trip Generation Manual, 11th Edition* published by the ITE, Multifamily Housing (Low-Rise) *includes apartments, townhouses, and condominium located within the same building with at least three other dwelling units and that have two or three (floors) levels.* Trip generation for the existing 1-unit of multifamily housing (low-rise) was calculated using the current ITE *Trip Generation, 11th Edition*.

According to the *Trip Generation Manual, 11th Edition* published by the ITE, “*a Marijuana Dispensary is a stand-alone facility where cannabis is sold to patients or retail consumers in a legal manner.*” Trip generation for the proposed 1,525 square foot cannabis retailer was calculated using the current ITE *Trip Generation, 11th Edition* based on square footage for the

“Peak of the Generator” and the “Peak of the Adjacent Street”. We chose the larger of the trip generation values, “Peak of Generator” for 1,525 square feet.

According to the *Trip Generation Manual, 11th Edition* published by the ITE, a Small Office Building “is the same as a general office building (Land Use 710) but with less than or equal to 10,000 square feet of gross floor area. The building typically houses a single tenant. It is a location where affairs of a business, commercial or industrial organization, or professional person or firm are conducted.” Trip Generation for the proposed 848 square foot small office was calculated using the current ITE *Trip Generation, 11th Edition*.

We calculated the trip generation for the existing restaurant and apartment and for the proposed cannabis retailer and supporting office space. The attached Table 1 – Trip Generation Comparison and Summary tabulates the trip generation of the former restaurant and apartment and the proposed cannabis retailer. The existing restaurant and one apartment would generate 22 vehicle trips during the weekday AM peak hour, 26 vehicle trips during the weekday PM peak hour, and 18 vehicle trips during a Saturday peak hour. The proposed cannabis retailer and small office would generate 27 vehicle trips during the weekday AM peak hour, 39 vehicle trips during the weekday PM peak hour, and 46 vehicle trips during the Saturday peak hour.

Table 1 also shows the change in the number of weekday AM and PM peak hour trips and Saturday peak hour trips. The increase in the number of peak hour trips is 5 vehicle trips during weekday AM peak hour trips, 13 vehicle trips during the weekday PM peak hour, and 28 vehicle trips during the Saturday peak hour.

According to Transportation Impact Analysis for Site Development, published by the Institute of Transportation Engineers (ITE), an increase of less than 100 vehicle trips would not change the level of service of the local street network nor appreciably increase the volume-to-capacity ratio of an intersection approach. Also, NJDOT Access Management Code considers a significant increase in trips greater than 100 peak hour trips AND greater than a 10 percent increase in previously anticipated daily trips. Therefore, the proposed development is not anticipated to significantly impact the operations of the local streets. Based on industry guidelines from the Institute of Transportation Engineers (ITE) as well as the NJDOT Access Code, the new vehicle trips generated by the proposed change of use from a restaurant and apartment to a cannabis retailer would not have a significant impact on traffic operations. Furthermore, the traffic generated to and from the property’s parking lot would be distributed on Sea Drift Avenue to Bay Avenue and to Shore Drive, further lessening any potential traffic impacts.

We were able to research the NJDOT website and find traffic volumes on Bay Avenue between Sea Drift Avenue and Atlantic Street from Monday, June 25 to Thursday, June 28, 2018. These traffic volumes show the two-way traffic volumes on Bay Avenue as between 250 and 325

vehicles per hour during the AM peak period and between 375 and 450 vehicles per hour during the PM peak hour. If all the trips generated by the proposed cannabis retailer were to use Bay Avenue only, those trips would be about 16 percent of the total traffic along Bay Avenue. The restaurant and apartment traffic were about 9 percent of the total traffic volumes on Bay Avenue. But again, the traffic to and from the parking lot would be distributed to Bay Avenue and Shore Drive, further lessening the traffic impacts generated by the property. Typically, traffic volumes can vary from day to day by more than 10 percent. The traffic volumes collected from the NJDOT website show that the traffic volumes during the AM and PM peak period fluctuate by 10 percent to 15 percent between Tuesday, June 26, 2018, and Wednesday, June 27, 2018. Therefore, the increase in traffic volumes generated by the change of use from a restaurant and apartment to a cannabis retailer would be insignificant and not noticed by drivers in the area.

Parking Requirements

The total space within the building is 2,373 square feet. Based on the local parking requirement of 1 parking space per 600 square feet pursuant to the Borough's Ordinance 21-65.14.D(7a), the 2,373 square feet of business/commercial/retail store use would require 4 parking spaces. The parking lot provides 17 parking spaces, including 1 ADA parking space, more than 4 times the required parking.

Conclusion

Based on the number of trips that would be generated during the weekday AM and PM peak hours being less than the industry standard of 100 peak hour trips, and the fact that there are two main roadways, Bay Avenue and Shore Drive, to distribute the traffic generated by the proposed cannabis retailer, the traffic generated by the proposed cannabis retailer would not have a significant impact on the operation of the surrounding streets.

Using the local Ordinance requirements for parking for the currently proposed cannabis retailer, the total parking requirement is 4 parking spaces, whereas 17 parking spaces are provided. The proposed parking supply of 17 parking spaces is over 4 times more than required by the local Ordinance.

Please contact me if you have any questions.

Sincerely,



Lee D. Klein, P.E., PTOE
NJPE 24GE03710400
PTOE Certification 1627

C:\Users\Leekl\Documents\WORK\Highlands-SeaGrass\Klein_TEPE_272BayAvHighlands_013023.docx

**Table 1 - Trip Generation Comparison and Summary
272 Bay Avenue, Highlands, Monmouth County, NJ**

CODE	LAND USE	AMOUNT	WEEKDAY				SATURDAY		
			AM PEAK HOUR		PM PEAK HOUR		PEAK HOUR		
			IN	OUT	TOTAL	IN	OUT	TOTAL	
EXISTING									
932	H-T (Sit-Down) Restaurant (Peak of Generator)	1,525 SF	12	9	21	13	12	8	17
932	H-T (Sit-Down) Restaurant (Street Peak)	1,525 SF	8	7	15	8	5	8	17
932	H-T (Sit-Down) Restaurant (Peak of Generator)	30 Seats	11	7	18	12	11	8	16
932	H-T (Sit-Down) Restaurant (Street Peak)	30 Seats	7	6	14	7	5	8	16
220	Low-Rise Apartment (Average Rate)	1 units	0	1	1	1	0	1	1
TOTAL EXISTING TRIP GENERATION			12	10	22	14	12	9	18
PROPOSED									
882	Marijuana Dispensary (Peak of Generator)	1,525 SF	14	12	26	18	19	22	44
882	Marijuana Dispensary (Street Peak)	1,525 SF	8	8	16	14	15	22	44
712	Small Office Building (General Urban/Suburban)	848 SF	1	0	1	1	1	1	2
TOTAL EXISTING TRIP GENERATION			15	12	27	19	20	24	46
CHANGE IN NUMBER OF VEHICLE TRIPS			3	2	5	5	8	14	28

SOURCE: *Trip Generation, 11th Edition*, published by the Institute of Transportation Engineers (ITE)

NOTE: ## - Indicates an INCREASE in the number of trips from existing to proposed

Google Maps

272 Bay Ave

LOCATION MAP

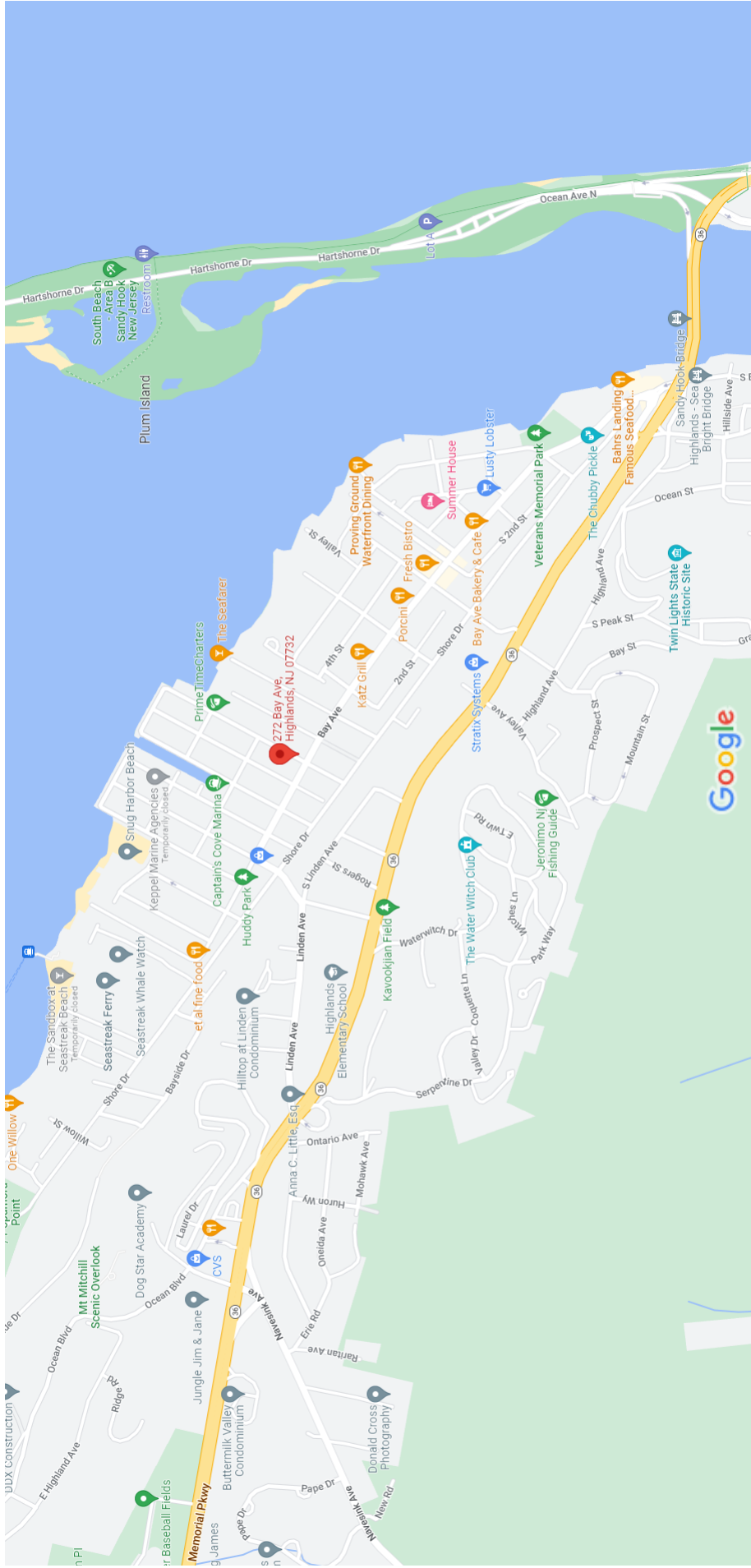

Map data ©2023 Google 500 ft



HGPB- R2000

February 3, 2023

Nancy Tran, Land Use Board Secretary
Borough of Highlands Land Use Board
42 Shore Drive
Highlands, New Jersey 07732

Via Email (ntran@highlandsborough.org)

**Re: Sea Grass NJ, LLC
272 Bay Avenue
Block 72, Lot 12 & Block 73, Lot 2
Central Business District (CBD) Zone
Redevelopment Zone C-RO-1
Minor Site Plan
& Conditional Use Variance
First Engineering Review**

Dear Ms. Tran:

As requested, we have reviewed the above-referenced application in accordance with the Borough of Highlands Zoning and Land Use Regulations section entitled Part 3, Subdivision and Site Plan Review, Article VI, Application Procedure, and Article VIII, Plat and Plan Details, Section 21-58.E – Preliminary Site Plan.

The applicant submitted the following documents in support of this application:

1. Preliminary & Final Major Site Plans prepared by Brent N. Papi, Jr., PE, of East Point Engineering, LLC, dated November 21, 2022, and last revised January 23, 2023, consisting of ten (10) sheets.
2. Architectural Plans prepared Shissias Design + Development, dated January 25, 2023, consisting of three (3) sheets.
3. Land Use Board Application and supporting documents, dated December 6, 2022.
4. Zoning Permit Application and supporting documents, dated November 3, 2022.
5. Statement of Design Waivers, dated January 25, 2023.
6. Traffic Report prepared by Klein Traffic Consulting, LLC, dated January 27, 2023, consisting of six (6) sheets.

Based on our review of the submitted documents, we offer the following comments for the Board's consideration:

A. Project Description

The 2,300 square foot property is currently a developed corner lot with an existing commercial building (restaurant/bar) and a 7,000 square foot existing parking lot across the street. The site is located in the Central Business District (CBD) Zone of the Borough with frontage along Bay Avenue (County Route 8). With this application, the applicant is seeking minor site plan and conditional use (variance) approval and is proposing to renovate and convert the existing commercial building into a cannabis retail store and improve the existing parking lot across the street. The proposed cannabis retail use is a permitted conditional use in the CBD Zone.



Le: Nancy Tran, Land Use Board Secretary
Borough of Highlands Land Use Board

Re: Sea Grass NJ, LLC
272 Bay Avenue
Block 72, Lot 12 & Block 73, Lot 2
Central Business District (CBD) Zone
Redevelopment Zone C-RO-1
Minor Site Plan
& Conditional Use Variance
First Engineering Review

B. Planning and Zoning

1. The subject property is located within the CBD Zone. The applicant has elected to prepare the application in accordance with the CBD Zone requirements and is not seeking approval under the Redevelopment Plan.
2. In accordance with Section 21-91 of the Ordinance regarding CBD Zone criteria, existing/proposed bulk criteria are noted as follows:

CBD Zone	Required	Existing	Proposed
Minimum Lot Size (Lot 12, Block 72)	NA	2,300 SF	2,300 SF
Minimum Lot Size (Lot 2, Block 73)	NA	7,000 SF	7,000 SF
Minimum Lot Frontage – (Lot 12, Block 72)	NA	23'	23'
Minimum Lot Frontage – (Lot 2, Block 73)	NA	70'	70'
Minimum Lot Depth – (Lot 12, Block 72)	NA	100'	100'
Minimum Lot Depth – (Lot 2, Block 73)	NA	100'	100'
Minimum Front Yard Setback – Bay Avenue (County Route 8)	0'	-1.78' ^(E)	-1.78' ^(E)
Minimum Rear Yard Setback	12'	10.8'	10.8'
Minimum Side Yard Setback*	0' or 5' min.	0.61' ^(E)	0.61' ^(E,V)
Maximum Building Height	36'	<36'	<36'
Maximum Building Coverage**	35%	83.0% ^(E)	77.9% ^(V)
Maximum Lot Coverage (Lot 12, Block 72)	80%	100% ^(E)	100% ^(E,V)
Maximum Lot Coverage (Lot 2, Block 73)	80%	2.8%	2.8%



**Le: Nancy Tran, Land Use Board Secretary
Borough of Highlands Land Use Board**

**Re: Sea Grass NJ, LLC
272 Bay Avenue
Block 72, Lot 12 & Block 73, Lot 2
Central Business District (CBD) Zone
Redevelopment Zone C-RO-1
Minor Site Plan
& Conditional Use Variance
First Engineering Review**

CBD Zone	Required	Existing	Proposed
Floor Area Ratio	0.65	1.31 ^(E)	1.26^(V)

- (E) – Existing Non-conformity
- (C) – Calculated
- (W) – Waiver
- (V) – Variance
- NA – Not Applicable

3. It is noted that the CBD zone considers principal use parking as a “conditional use.”
4. It is also noted that accessory uses are defined in the Ordinance as clearly incidental or subordinate to the principal building or use and *generally* located on the same lot with such principal building or use. In this proposal, the applicant is providing for parking on a separate lot. The Board shall determine the implications accordingly in conjunction with the Board Attorney.
5. Although cannabis retail is a conditionally permitted use in the CBD Zone, the development does not meet the following requirements of Section 21-97.M of the Ordinance:
 - a. Section 21-97.M of the Ordinance permits one (1) cannabis retailer in the CBD Zone provided that applicable Article XI Design Standards are met, whereas the applicant does not meet several applicable design standards.
 - b. It is noted that per Section 21-97.M.2 of the Ordinance, “the cannabis retailer shall not be located within 1,000 feet of any school”. The proposed retail building property appears to be greater than 1,000 feet from the elementary school. The separate parking lot may be within 1,000 feet. It is unclear whether the separate parking lot would count in this respect. The Board should determine if this requires any additional consideration under a d(3) conditional use variance.

Since all of the conditional use requirements are not met, a “d(3)” use variance is therefore required.

6. The following design waivers are required for the building lot:
 - a. Section 21-65.1.A of the Ordinance requires that he provisions of the zoning regulations with respect to height, minimum lot area, yard requirements, and the like



**Le: Nancy Tran, Land Use Board Secretary
Borough of Highlands Land Use Board**

**Re: Sea Grass NJ, LLC
272 Bay Avenue
Block 72, Lot 12 & Block 73, Lot 2
Central Business District (CBD) Zone
Redevelopment Zone C-RO-1
Minor Site Plan
& Conditional Use Variance
First Engineering Review**

shall be complied with. The existing building does not comply with multiple bulk standards.

- b. Section 21-65.5.C.1 of the Ordinance requires that commercial driveways be a minimum of 15' wide. The applicant proposes 10.8'.
- c. Section 21-65.10.C.1-2 of the Ordinance indicates that in non-residential zones landscape plans shall specify the location of the planting material, their minimum size at time of planting and size at full growth, quantity, variety, species (common name) and method of planting, and that a minimum of 10% of the area of the site shall be landscaped. The applicant cannot provide landscaping accordingly given that the balance of the site is pre-existing building and parking area.
- d. Section 21-65.11 of the Ordinance speaks to lighting requirements for drives, aisles, and parking areas. The applicant did not provide any explicit lighting evaluation for the rear driveway of the building nor documentation of compliance with the Ordinance standards there.

7. The following design waivers are required for the Sea Drift parking lot:

- a. Section 21-65.5.A of the Ordinance requires that driveways be located a minimum of 25' from any intersection, whereas the existing driveway entrance is less than 25'.
- b. Section 21-65.14.A of the Ordinance indicates that in conjunction with any principal building or any use of land, there shall be provided sufficient parking spaces to meet the minimum requirements specified herein. The required parking may either be provided on- or off-site. **Any part of the parking requirement located on a private lot other than the one on which the use is located shall be subject to a cross easement or agreements noted on the deed and recorded at the County Clerk's Office.** The applicant shall confirm how they plan to address this matter.
- c. Section 21-65.14.D.1 of the Ordinance indicates that all parking areas shall be paved, or constructed in accordance with CAFRA regulations with gravel or porous pavers, subject to the review and approval of the Borough or Board Engineer; shall be suitably drained and maintained in good condition; and all spaces and directional instructions shall be clearly marked and maintained so as to be clearly visible. The Sea Drift parking lot is currently gravel. The applicant's proposal is to add hard surface for ADA purposes, but to maintain the balance as gravel. The Board should determine if gravel is acceptable, or whether paving is required. If paving is required, the lot coverage by definition would increase and may require additional relief.



**Le: Nancy Tran, Land Use Board Secretary
Borough of Highlands Land Use Board**

**Re: Sea Grass NJ, LLC
272 Bay Avenue
Block 72, Lot 12 & Block 73, Lot 2
Central Business District (CBD) Zone
Redevelopment Zone C-RO-1
Minor Site Plan
& Conditional Use Variance
First Engineering Review**

- d. Section 21-65.14.D.2 of the Ordinance requires that parking spaces or access aisles shall have a minimum setback of at least one-half (1/2) the required setback for the principal building. This condition is not met, but is a pre-existing condition.
8. To be entitled to bulk variance relief, the applicant must provide proof to satisfy the positive and negative criteria pursuant to N.J.S.A. 40: 55D-70c for the bulk variances:
- a. Positive Criteria. The applicant must prove either a hardship in developing the site in conformance to the zone standards due to exceptional narrowness, shallowness, or shape of the property; or due to exceptional topographic conditions or physical features uniquely affecting the property; or due to an extraordinary and exceptional situation affecting the property or its lawful existing structures. Alternatively, the applicant may satisfy the positive criteria by demonstrating that the variance relief will promote a public purpose as set forth in the Municipal Land Use Law (N.J.S.A. 40:55D-2) and thereby provide improved community planning that benefits the public and the benefits of the variance substantially outweigh any detriment.
 - b. Negative Criteria. The applicant must also show that the bulk variances can be granted without substantial detriment to the public good or substantially impairing the intent and purpose of the zone plan. This requires consideration of the impact of the proposed variances on surrounding properties and a determination as to whether or not the variance would cause such damage to the character of the neighborhood as to constitute a substantial detriment to the public good.
9. In order for the Board to approve a "d(3)" variance, the applicant must satisfy the following:

With respect to the “positive criteria”, our courts have held that applicants seeking a conditional use variance must show that the site will accommodate the problems associated with the use even though the proposal does not comply with the conditions the Ordinance established to address those problems. This leaves the Board to focus on the *particular suitability* of the site in accommodating the use despite its failure to meet the conditions. The Board shall consider whether there are particular features of the site that lessen or entirely offset the failure to meet the Ordinance conditions and then whether there are conditions that the Board could require that would offset the failure.

With respect to the “negative criteria”, the applicant shall demonstrate that the variance can be granted without substantial detriment to the public good. The focus here should be on the impact of the proposed use variance on adjacent properties and a determination of whether or not it will cause such damage to the character of the neighborhood as to constitute substantial detriment to the public good.



**Le: Nancy Tran, Land Use Board Secretary
Borough of Highlands Land Use Board**

**Re: Sea Grass NJ, LLC
272 Bay Avenue
Block 72, Lot 12 & Block 73, Lot 2
Central Business District (CBD) Zone
Redevelopment Zone C-RO-1
Minor Site Plan
& Conditional Use Variance
First Engineering Review**

Additionally, the applicant shall demonstrate that the grant of the variance for this specific project at the designated site is reconcilable with the Borough’s legislative determination that the condition should be imposed on all conditional uses in that zoning district, such that it will not substantially impair the intent and purpose of the zone plan and zoning ordinance.

- 10. If the applicant is pursuing consideration under the standard CBD Zone, **ad(4) use variance for floor area may also be implicated**. We note that this is a pre-existing building and condition, and it is unclear whether any prior approvals were granted.

C. Site Requirements & Layout

- 1. The applicant does not propose any off-site improvements as part of this application.
- 2. The site circulation includes one (1) driveway entrance on Sea Drift Ave. The driveway allows ingress and egress directly into the proposed parking facilities with no circulation around the site.
- 3. Under the CBD Zone, for the cannabis retail use, Section 21-65.14.D.7.a of the Ordinance requires one (1) off-street parking space per 600 square feet of gross floor area. The following is a summary of the required off-street parking spaces:

Cannabis Retail:	1 space/600 SF	@ 2,373 SF	<u>3.96 spaces</u>
		Total Required Spaces:	4 spaces

A total of 4 parking spaces are required per CBD Zone criteria and 17 parking spaces are provided therefore no design waiver is required. Refer to comment 5.b above regarding reservation of parking spaces.

- 4. Table 208.2 of the 2010 ADA standards indicates that 1 ADA accessible parking space is to be provided when there are between 0 and 25 parking spaces. The applicant is proposing one van-accessible parking space on the Sea Drift parking lot.
- 5. The applicant shall provide testimony on whether employee parking spaces will be reserved on-site at the Sea Drift parking lot.
- 6. The applicant shall provide testimony on truck loading areas required as part of the proposed improvements. The applicant has indicated that a driveway will be constructed at the back of the building that will be suitable for use by the typical Sprinter-type vans that will provide deliveries.



**Le: Nancy Tran, Land Use Board Secretary
Borough of Highlands Land Use Board**

**Re: Sea Grass NJ, LLC
272 Bay Avenue
Block 72, Lot 12 & Block 73, Lot 2
Central Business District (CBD) Zone
Redevelopment Zone C-RO-1
Minor Site Plan
& Conditional Use Variance
First Engineering Review**

D. Traffic Impact

1. The applicant provided a traffic impact report. The findings were that the proposed use is expected to only slightly increase the expected peak hour trip generation when compared to the pre-existing restaurant/bar and apartment use. The applicant's engineer shall provide testimony on the proposed traffic to be generated, circulation around the site, and whether any additional signage or pavement markings are necessary.
2. In our experience with cannabis retail facilities there can be a significant demand for on-site parking and pedestrian queuing along the facility's building and adjacent sidewalks. The applicant shall provide testimony on vehicular and pedestrian queuing expectations, logistics, and layout.
3. The applicant shall provide testimony as to the frequency and type of trucks that will access the site including those providing deliveries and garbage collection.
4. The applicant shall provide testimony on the trash and recyclables to be generated with the proposed use, along with the process, times, and frequency of refuse pickup.
5. We defer to the Borough Fire Official for review of the application with respect to emergency vehicle access and maneuvering, as well as traffic lane markings.

E. Technical Engineering

1. The proposed development will not disturb an area exceeding 1 acre, nor will it create more than a quarter acre of new impervious surfaces. Therefore, the project is not considered a "major development" as defined by NJAC. 7:8, and is not subject to the NJDEP Stormwater Management stormwater quantity, quality and recharge requirements of a major development.
2. The applicant shall provide testimony on existing drainage patterns and any potential changes or impacts.
3. The applicant shall provide testimony regarding the suitability of existing utility connections and/or additional utility connections or improvements necessitated by the subject application. All proposed utility improvements shall be shown on the plans including proper trench restoration.
4. The applicant shall confirm no sanitary sewer or water utilities will be impacted as a result of the subject application.
5. The applicant shall provide testimony on the existing fire service water line size and location. We defer to the Borough Fire Official for review.



**Le: Nancy Tran, Land Use Board Secretary
Borough of Highlands Land Use Board**

**Re: Sea Grass NJ, LLC
272 Bay Avenue
Block 72, Lot 12 & Block 73, Lot 2
Central Business District (CBD) Zone
Redevelopment Zone C-RO-1
Minor Site Plan
& Conditional Use Variance
First Engineering Review**

6. The applicant shall provide testimony on the existing lighting levels throughout the entire site and compliance with Section 21-65.11 of the Ordinance.
7. All outdoor lighting during non-operating hours of the business on site, not necessary for safety and security purposes, shall be reduced, activated by motion-sensor devices or turned off. The applicant shall provide testimony on the proposed lights and hours of operation. It is recommended they be placed on a timer.
8. The project site is located in the Coastal Area Facilities Review Act (CAFRA) Zone. The applicant shall comply with any applicable NJDEP requirements. The applicant has indicated that a permit is not required for this application. We defer further review to NJDEP.
9. The subject property is located within the “AE” Flood Zone with a Base Flood Elevation (BFE) of 11 feet. The applicant shall specify on the plans the proposed finished floor elevation. Additionally, it is recommended that the applicant obtains an Elevation Certificate for the subject property.

We defer further review to the Flood Plain Administrator and Construction Official for any applicable building requirements accordingly.

10. The applicant shall provide testimony on any proposed flood mitigation measures.
11. The Building Department should review the architectural plans for ADA compliance.

F. General

1. The applicant shall consider all performance standards for the operations of the proposed facility including but not limited to noise, glare, pollutants, and refuse management, and provide testimony on said standards. Specifically, the applicant shall provide testimony on odor control.
2. The applicant shall provide testimony on any proposed signage. All signage shall be indicated on the plans and comply with Section 21-65.19 of the Ordinance.
3. The applicant shall provide testimony regarding any mechanical equipment proposed, such as A/C units and backup power generators, as well as any requirements for electric and other meters including any required platforms.
4. The applicant has indicated that no exterior renovations are proposed for the building. The applicant shall discuss interior renovations they have proposed.



**Le: Nancy Tran, Land Use Board Secretary
Borough of Highlands Land Use Board**

**Re: Sea Grass NJ, LLC
272 Bay Avenue
Block 72, Lot 12 & Block 73, Lot 2
Central Business District (CBD) Zone
Redevelopment Zone C-RO-1
Minor Site Plan
& Conditional Use Variance
First Engineering Review**

5. A note shall be added to the plans indicating that all improvements are to be ADA compliant, where applicable.
6. A note shall be added to the plans stating that any/all existing curb, sidewalk, roadway, and other objects either in poor condition or damaged by construction should be repaired and/or replaced to the satisfaction of the Borough Engineer.
7. Testimony shall be provided regarding the proposed uses. The applicant shall be prepared to discuss the following:
 - a. Security and access.
 - b. Hours of operation.
 - c. Number of employees (total and maximum per shift).
 - d. Frequency and type of trucks that will access the site.
 - e. Type of goods to be sold.
8. Approvals or waivers should be obtained from any outside agencies having jurisdiction. These may include, but shall not be limited to, the following:
 - a. New Jersey Department of Environmental Protection
 - i. CAFRA
 - b. New Jersey Cannabis Regulatory Commission
 - c. Floodplain Official
 - d. Township of Middletown Sewerage Authority
 - e. New Jersey American Water
 - f. Borough Fire Official
 - g. Monmouth County Board of Health
 - h. Monmouth County Planning Board

We reserve the opportunity to further review and comment on this application and all pertinent documentation, pursuant to testimony presented at the public hearing. If you have any questions regarding this matter, please do not hesitate to contact our office.

Very truly yours,

T&M ASSOCIATES

EDWARD W. HERRMAN, P.E., P.P., C.M.E., C.F.M.
LAND USE BOARD ENGINEER



**Le: Nancy Tran, Land Use Board Secretary
Borough of Highlands Land Use Board**

**Re: Sea Grass NJ, LLC
272 Bay Avenue
Block 72, Lot 12 & Block 73, Lot 2
Central Business District (CBD) Zone
Redevelopment Zone C-RO-1
Minor Site Plan
& Conditional Use Variance
First Engineering Review**

EWH:EJC

cc: Michael Muscillo, Borough Administrator (mmuscillo@highlandsborough.org)
Ron Cucchiaro, Esq., Land Use Board Attorney (RCucchiaro@Weiner.law)
Brian O'Callahan, Zoning Officer (bcallahan@middletownnj.org)
Sea Grass NJ, LLC, Applicant (idrwhelan@gmail.com)
Leonel Cervantes, Owner (leocervantes@hotmail.com)
John B. Anderson, III, Esq., Applicant's Attorney (janderson@fsfm-law.com)
Brent N. Papi, Jr., PE, Applicant's Engineer (bpapi@eastpointeng.com)
Shissias Design & Development, Applicant's Architect (kevin966@gmail.com)

G:\Projects\HGPB\R2000\Correspondence\Tran_EWH_Sea Grass NJ LLC_First Engineering Review.docx