



CITY OF GROSSE POINTE WOODS DEPARTMENT OF PUBLIC SAFETY

Date: November 10, 2022

To: Frank Schulte, City Administrator

From: John G. Kosanke, Director *JK*

Subject: Locker Room Renovation Project – Budget Amendment

The Department of Public Safety is recommending an update of the department’s obsolete locker room. The current lockers are small and inadequate for the storage of an officer’s uniform and equipment. The cost of renovations was approved in the FYE 2022-2023 budget for an amount of \$80,000.00 in the Public Safety Municipal Improvement Fund 401-902-977.102.

Quotes for the project were received from two vendors:

The Casper Corporation	24081 Research Drive	Farmington, MI 48335	\$81,896.33
Tiffin Metal Products	450 Wall Street	Tiffin, Ohio 44803	\$81,110.00

Although the quote from Tiffin is less than the quote from Casper by a difference of \$786.33, the department is choosing to accept the quote from The Casper Corporation because it is a local company which has achieved satisfactory renovation results for similar projects in area departments including Canton, Grosse Pointe City, Royal Oak, Sterling Heights, and Warren.

The total cost quoted by The Casper Corporation includes freight and installation services. Removal of the old lockers and painting of the rooms will be done by employees of the Department of Public Works. The city attorney has reviewed and approved the Standard Terms and Conditions on the quote. A copy of the quote, renovation plans, and Certificate of Liability Insurance are attached.

The Department of Public Safety is recommending a budget amendment in the amount of \$1,896.33 to cover additional costs necessary for the locker room renovation project. The cost of construction materials has gone up significantly since the budget request was made last year.

I am recommending approval of the purchase and installation along with a budget amendment in the amount of \$1,896.30 from the General Funds balance account 101-000-699.000, Transfer from Prior Year Reserve, into account 401-902-977.102, Improvement – Public Safety - Municipal Improvement Fund.

I do not believe any benefit will accrue to the City by seeking further bids. Approved for Council consideration.

Frank Schulte

Frank Schulte, City Administrator

11-10-22

Date

Fund Certification:
Account numbers have been verified as presented.

Shawn Murphy

Shawn Murphy, Comptroller/Treasurer

11-10-22

Date

Casper Corporation, The
 24081 Research Drive
 Farmington, MI 48335
 Phone: (248) 442-9000
 Fax: (248) 442-9010
 http://www.caspercorp.com



CUSTOMER QUOTE

18294-50211

Expires: 12/7/2022

Bill To

City of Grosse Pointe Woods
 Department of Public Safety
 20025 Mack Plaza Drive
 Grosse Pointe, MI 48236

Install To

City of Grosse Pointe Woods
 Department of Public Safety
 20025 Mack Plaza Drive
 Grosse Pointe, MI 48236

project #	salesperson	quote name	payment terms	print date
18294	Bart Spencer	BS18294-2C - 11/7/22	Deposit / Balance Upon Receipt	11/7/2022

line	qty	unit	part # / description	price ea	ext price
1	1.00	EA	Personal Duty Lockers / Mens' Locker Room: 20 Lokers 84"H X 18"W X 24"D with bench drawer 18 Lockers 84"H X 18"W X 24"D with pullout drawer Women's Locker Room: 1 Locker 72"H X 18"W X 24"D with pullout drawer All lockers include: rubber boot tray, document holder, full width shelf with clothes hanger, (2) hanger assemblies, mirror and sloped tops Women's Locker Room: 4 Two Tier Lockers 72"H X 18"W X 24"D and include rubber boot tray, hanger bracket assembly, mirror, (4) single hooks per tier, and sloped tops	\$67,138.98	\$67,138.98

line	qty	unit	part # / description	price ea	ext price
2	1.00	EA	Installation Services / Labor to receive, stage, redeliver, install, and remove packaging debris to customer supplied dumpster	\$12,875.00	\$12,875.00

line	qty	unit	part # / description	price ea	ext price
3	1.00	EA	Freight / Charges	\$1,882.35	\$1,882.35

BS18294-2C - 11/7/22 (Option Total)

subtotal	\$81,896.33
sales tax	\$0.00
total	\$81,896.33

Casper Corporation, The
24081 Research Drive
Farmington, MI 48335
Phone: (248) 442-9000
Fax: (248) 442-9010
<http://www.caspercorp.com>



CUSTOMER QUOTE

18294-50211

Standard Terms and Conditions

Delivery (Dock, Elevator, and Dumpster): The Casper Corporation will notify your designated contact person twenty-four (24) hours prior to delivery. Dock space and /or elevator availability will be arranged by you and made available at no cost to The Casper Corporation. A dumpster for removal of all shipping and packing materials will be provided at no charge to The Casper Corporation. Dumpster must be conveniently located and easily accessible at all times during installation of the equipment.

Storage: If, for any reason, you are not ready to receive the materials and storage is required, storage and handling fees will be added to your invoice. If product is stored on site, it must be in a dry environment and kept in the same packaging materials as delivered. If product is stored by customer, customer takes responsibility for product at time of delivery.

Space Requirements: The space shall be ready for installation and free and clear of all obstructions. If it is not and there is a resulting delay, then the additional man hours will be billed. The space shall be properly lighted. If additional lighting is required to perform the work safely, the additional cost will be invoiced. It is your responsibility to be certain the space is suitable for the installation of this equipment, i.e., adequate fire protection, clearances, and floor load capacity.

Electrical: Electrical power for tools, equipment and lighting will be supplied to The Casper Corporation at no cost.

Freight: Materials will be shipped pre-paid and added to the invoice if necessary. If any freight damage occurs, please notify The Casper Corporation within 24 hours to report back to vendor.

Installation: Installation is in addition to the price of the materials. Labor is planned as straight time unless otherwise noted. Overtime occurring not at Casper's discretion will be added to your invoice.

Taxes: All applicable sales taxes, as required by law, will be billed.

Payment: This product has been specifically designed and will be specifically manufactured for your unique requirements. A non-refundable down payment of 50% of the contract amount is due within ten (10) calendar days of contract award. The balance will be invoiced upon substantial completion and is due net ten (10) days. One and one-half percent (1.5%) interest per month will be charged on any unpaid balance after thirty (30) days. If the installation is not totally complete upon final invoicing, a holdback of reasonable value is allowed without incurring interest charges.

Warranty: See Manufacturers Warranty.

Insurance Certificates, Permits, and Fees: We reserve the right to pass on any additional costs to obtain insurance certificates, building permits, or miscellaneous fees that have not been previously identified and/or specified in our proposal but are required to complete the project.

Change Orders and / Or Cancellation: If, for any reason, you cancel the order, any cancellation, restocking and handling charges will be invoiced. Change orders requested after receipt of your purchase order may also incur additional charges.

_____ **Initial for Acceptance of Terms**

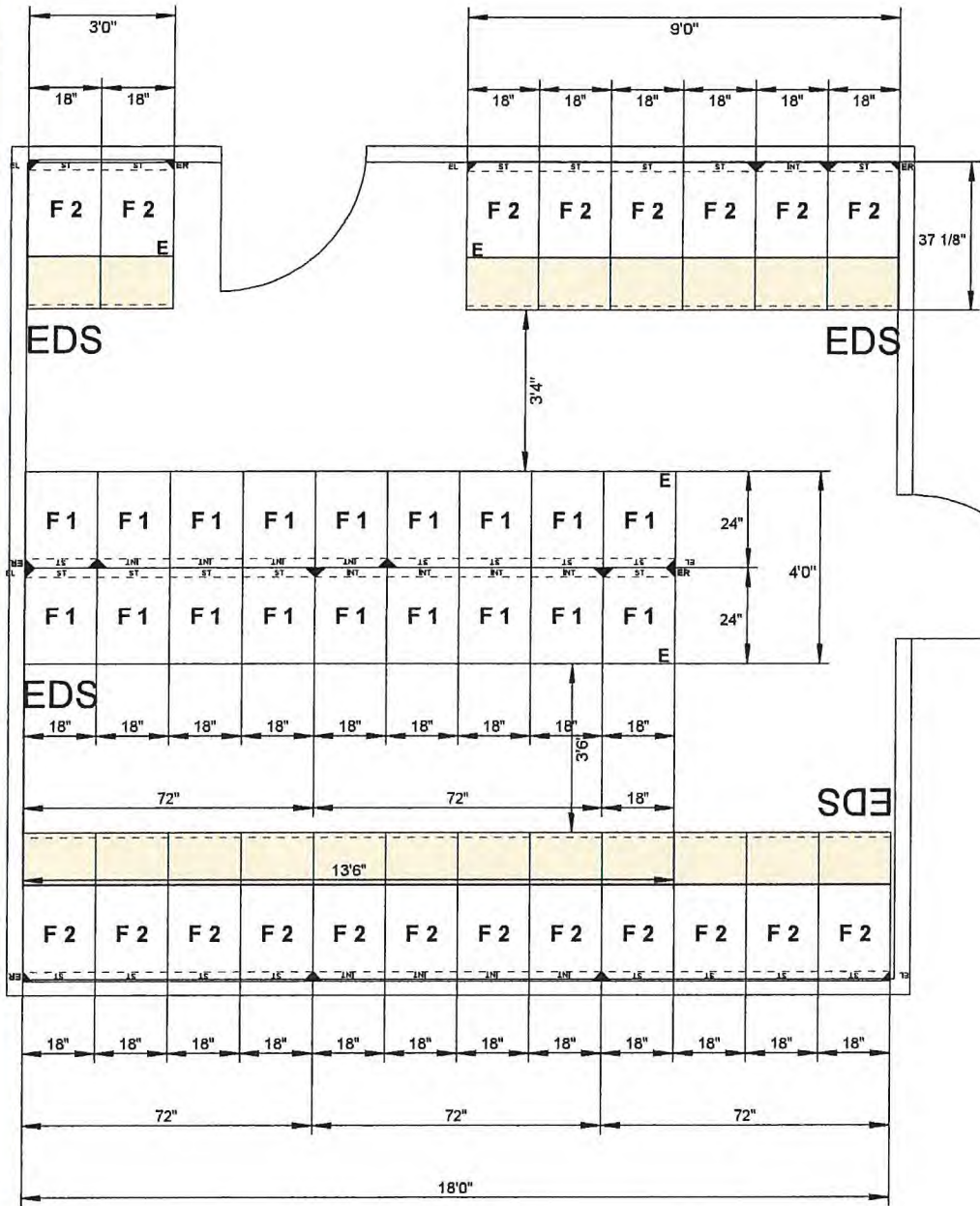

38 Lockers

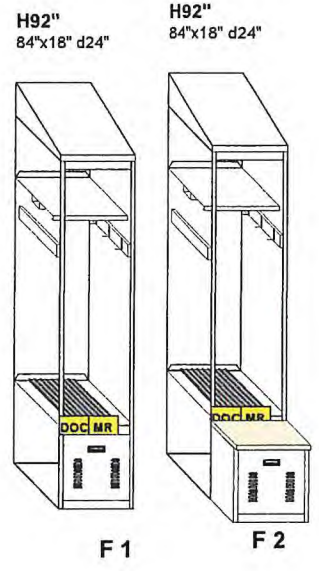

The Casper Corporation
 Corporate (Detroit) Headquarters (248) 442-9000
 Okemos (Lansing) Office (517) 321-4697
 Grand Rapids Office (616) 866-1606
 Kalamazoo Office (269) 344-7588
 Saginaw Office (989) 799-4312

Project Name:
**Locker Upgrade
 Mens and
 Womens**

Project #:
BS18294-2C

Drawn by:
BS

Date Printed:
07/18/2022

Scale
 1:45

Rev level:

APPROVAL
 This drawing Approved By: _____

Dated _____

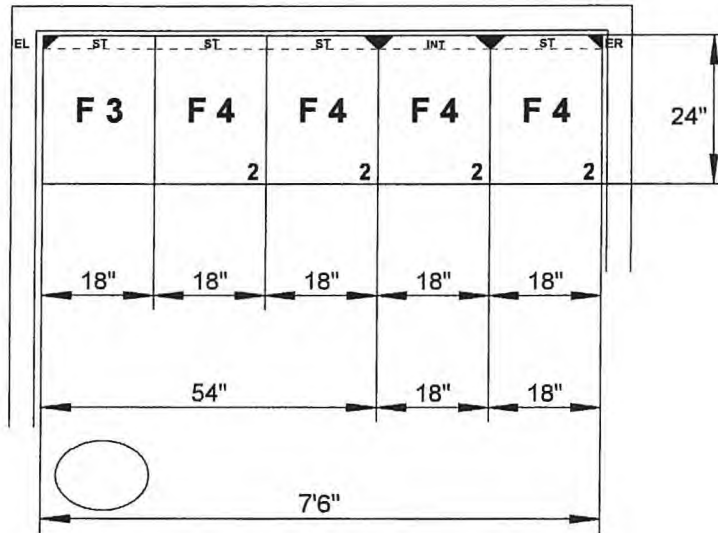

H80"
72"x18" d24"

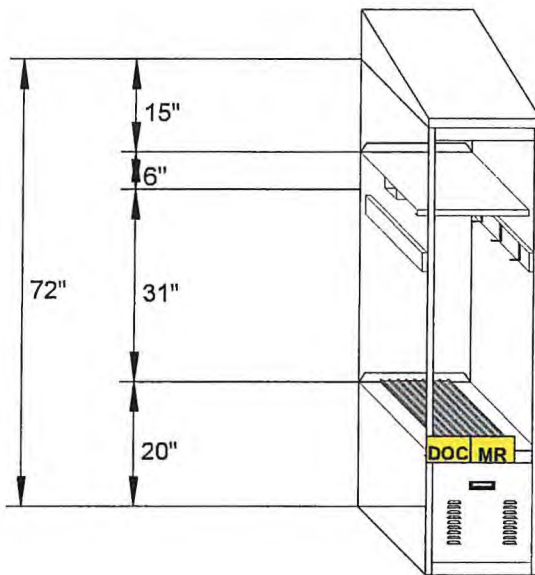

F 3

H80"
72"x18" d24"

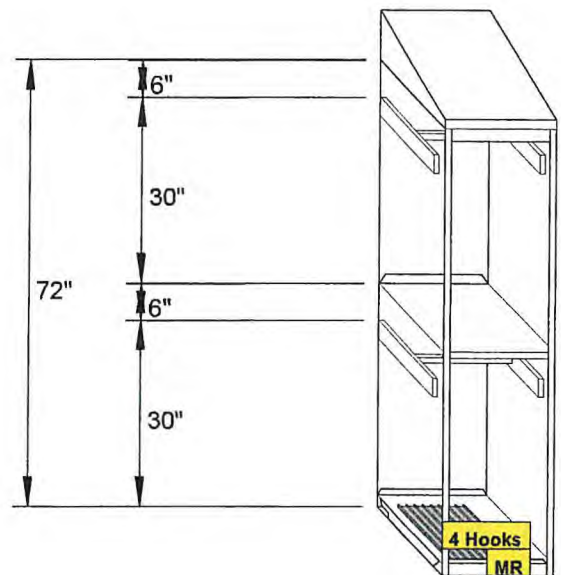

F 4



The Casper Corporation
Corporate (Detroit) Headquarters (248) 442-9000
Okemos (Lansing) Office (517) 321-4697
Grand Rapids Office (616) 866-1606
Kalamazoo Office (269) 344-7588
Saginaw Office (989) 799-4312

Project Name:

**Locker Upgrade
Mens and
Womens**

Project #:
BS18294-2C

Drawn by:
BS

Date Printed:
07/18/2022

Scale
1:30

Rev level:

APPROVAL
This drawing Approved By:

Dated _____



CERTIFICATE OF LIABILITY INSURANCE

DATE (MM/DD/YYYY)
11/9/2022

THIS CERTIFICATE IS ISSUED AS A MATTER OF INFORMATION ONLY AND CONFERS NO RIGHTS UPON THE CERTIFICATE HOLDER. THIS CERTIFICATE DOES NOT AFFIRMATIVELY OR NEGATIVELY AMEND, EXTEND OR ALTER THE COVERAGE AFFORDED BY THE POLICIES BELOW. THIS CERTIFICATE OF INSURANCE DOES NOT CONSTITUTE A CONTRACT BETWEEN THE ISSUING INSURER(S), AUTHORIZED REPRESENTATIVE OR PRODUCER, AND THE CERTIFICATE HOLDER.

IMPORTANT: If the certificate holder is an ADDITIONAL INSURED, the policy(ies) must have ADDITIONAL INSURED provisions or be endorsed. If SUBROGATION IS WAIVED, subject to the terms and conditions of the policy, certain policies may require an endorsement. A statement on this certificate does not confer rights to the certificate holder in lieu of such endorsement(s).

PRODUCER Capital Insurance Group 1263 West Square Lake Road Bloomfield Hills MI 48302		CONTACT NAME: Ashley Laparl PHONE (A/C, No., Ext): 248-333-2500 FAX (A/C, No.): 248-333-2504 E-MAIL ADDRESS: certificates@cap-ins.com	
INSURED The Casper Corporation Etal James Casper Jr. 24081 Research Dr. Farmington Hills MI 48335		INSURER(S) AFFORDING COVERAGE INSURER A: Selective Insurance Co of South Carolina INSURER B: Selective Insurance Co of America INSURER C: INSURER D: INSURER E: INSURER F:	
		NAIC # 19259 12572	

VOK!
J.A.
11/10/22

COVERAGES **CERTIFICATE NUMBER:** 857880815 **REVISION NUMBER:**

THIS IS TO CERTIFY THAT THE POLICIES OF INSURANCE LISTED BELOW HAVE BEEN ISSUED TO THE INSURED NAMED ABOVE FOR THE POLICY PERIOD INDICATED. NOTWITHSTANDING ANY REQUIREMENT, TERM OR CONDITION OF ANY CONTRACT OR OTHER DOCUMENT WITH RESPECT TO WHICH THIS CERTIFICATE MAY BE ISSUED OR MAY PERTAIN, THE INSURANCE AFFORDED BY THE POLICIES DESCRIBED HEREIN IS SUBJECT TO ALL THE TERMS, EXCLUSIONS AND CONDITIONS OF SUCH POLICIES. LIMITS SHOWN MAY HAVE BEEN REDUCED BY PAID CLAIMS.

INSR LTR	TYPE OF INSURANCE	ADDL INSD	SUBR WVD	POLICY NUMBER	POLICY EFF (MM/DD/YYYY)	POLICY EXP (MM/DD/YYYY)	LIMITS
A	<input checked="" type="checkbox"/> COMMERCIAL GENERAL LIABILITY <input type="checkbox"/> CLAIMS-MADE <input checked="" type="checkbox"/> OCCUR GEN'L AGGREGATE LIMIT APPLIES PER: <input type="checkbox"/> POLICY <input checked="" type="checkbox"/> PROJECT <input checked="" type="checkbox"/> LOC OTHER:	Y		S 1996373	7/1/2022	7/1/2023	EACH OCCURRENCE \$ 1,000,000 ✓ DAMAGE TO RENTED PREMISES (Ea occurrence) \$ 500,000 MED EXP (Any one person) \$ 15,000 PERSONAL & ADV INJURY \$ 1,000,000 GENERAL AGGREGATE \$ 3,000,000 PRODUCTS - COMP/OP AGG \$ 3,000,000 \$
A	<input type="checkbox"/> ANY AUTO <input type="checkbox"/> OWNED AUTOS ONLY <input checked="" type="checkbox"/> HIRED AUTOS ONLY <input type="checkbox"/> SCHEDULED AUTOS <input checked="" type="checkbox"/> NON-OWNED AUTOS ONLY			S 1996373	7/1/2022	7/1/2023	COMBINED SINGLE LIMIT (Ea accident) \$ 1,000,000 ✓ BODILY INJURY (Per person) \$ BODILY INJURY (Per accident) \$ PROPERTY DAMAGE (Per accident) \$ \$
A	<input checked="" type="checkbox"/> UMBRELLA LIAB <input checked="" type="checkbox"/> OCCUR <input type="checkbox"/> EXCESS LIAB <input type="checkbox"/> CLAIMS-MADE DED <input checked="" type="checkbox"/> RETENTION \$ 0			S 1996373	7/1/2022	7/1/2023	EACH OCCURRENCE \$ 5,000,000 ✓ AGGREGATE \$ 5,000,000 \$
B	WORKERS COMPENSATION AND EMPLOYERS' LIABILITY ANY PROPRIETOR/PARTNER/EXECUTIVE OFFICER/MEMBER EXCLUDED? (Mandatory in NH) If yes, describe under DESCRIPTION OF OPERATIONS below	Y/N	N/A	WC 7987551	7/1/2022	7/1/2023	<input checked="" type="checkbox"/> PER STATUTE <input type="checkbox"/> OTH-ER E.L. EACH ACCIDENT \$ 1,000,000 ✓ E.L. DISEASE - EA EMPLOYEE \$ 1,000,000 E.L. DISEASE - POLICY LIMIT \$ 1,000,000

DESCRIPTION OF OPERATIONS / LOCATIONS / VEHICLES (ACORD 101, Additional Remarks Schedule, may be attached if more space is required)
Additional Insured: City of Grosse Pointe Woods with respect to the General Liability policy and work performed by the Named Insured.

CERTIFICATE HOLDER City of Grosse Pointe Woods Department of Public Safety 20025 Mack Plaza Drive Grosse Pointe MI 48236	CANCELLATION SHOULD ANY OF THE ABOVE DESCRIBED POLICIES BE CANCELLED BEFORE THE EXPIRATION DATE THEREOF, NOTICE WILL BE DELIVERED IN ACCORDANCE WITH THE POLICY PROVISIONS. AUTHORIZED REPRESENTATIVE
---	--