



CITY OF GROSSE POINTE WOODS

MEMORANDUM

Date: December 22, 2022
To: Frank Schulte, City Administrator
From: Beth Miro, Municipal Court Clerk
CC: Susan Como, Assistant City Administrator
Shawn Murphy, Treasurer/Comptroller
Subject: Municipal Court Office Renovation

Quotes were requested for the renovation of the main court office, including furniture, flooring, counter tops, etc. Only two quotes were received:

Table with 2 columns: Vendor Name and Price. Rows include Creative Office Interiors (\$45,566.86), Combs Carpentry (\$40,500.00), McMillan Brothers (No Quote Provided), Office Furniture Solutions (No Quote Provided), and Renovation Geeks (No Quote Provided).

After reviewing the two quotes received regarding the court renovation, I am recommending Creative Office Interiors be selected to do our renovation. This company is recommended by Allor Group, who did the renovation of the city hall offices. I feel they would be the best choice, despite a slightly higher price because of their expertise and experience in office renovations. While I'm sure Combs Carpentry does fine work, their specialty is not offices renovations. I feel most confident that Creative Office Interiors will be able to do the best job in renovating the court office.

The amount to cover the cost of the renovation is a budgeted item, with the account number: 101-136-977.000. The projected cost is \$566.86 over budget, but I will be able to use money from my operating supplies to cover this difference.

Fund Certification:
Account numbers and amounts have been verified as presented.

RECEIVED

JAN 03 2023

CITY OF GROSSE POINTE WOODS
CLERK'S DEPARTMENT

Signature of Shawn Murphy
Shawn Murphy, Treasurer/Comptroller

1-3-2023
Date

Signature of Frank Schulte
Frank Schulte, City Administrator

1-3-23
Date

Beth Miro

From: Creative Office Interiors Inc. <cointeriorsinc@msn.com>
Sent: Monday, December 12, 2022 1:47 PM
To: Beth Miro
Subject: SALES CONTRACT 6987
Attachments: SC6987.pdf; FINAL Document Sheet.pdf; City of Grosse Pointe Woods - FINAL COMBINED PLANS.pdf

Importance: High

CAUTION: This email originated from outside of the organization. DO NOT click links, open attachments or reply to this message unless you recognize the sender and know the content is safe:

Hi Beth,

Please find attached Sales Contract 6987 for the complete renovation project including, millwork, flooring, & systems furniture. Providing the full service for the renovation is one of the reasons that Jeff Allor recommended us as your vendor for this project. Attached is the following:

- Sales Contract 6987
- Floor Plan – Showing Electrical/Data location for your IT department.
- Millwork Drawing for Front Reception Desk.
- Document Sheet – Showing Finishes

We require a 50% deposit when you are ready to proceed.

If you have any questions, please feel free to give me a call. I look forward to beginning the project!

Thank you,
Debbie Tibaud

Creative Office Interiors, Inc.

25821 Jefferson Avenue
St. Clair Shores, MI 48081
Phone: 586.445.6155

Fax: 586.445.6164

E-mail: cointeriorsinc@msn.com

Website: www.creativeofficeinteriorsinc.com



Creative Office Interiors, Inc.

25821 Jefferson Avenue

St. Clair Shores, Michigan 48081

(586) 445-6155

Fax (586) 445-6164

REFER TO THIS NO.
WHEN PHONING
SALES CONTRACT
NO. 6987

(PAGE 1 OF 7)

Date: December 12, 2022

CUSTOMER

City Of Grosse Pointe Woods

ADDRESS

20025 Mack Ave.

CITY

Grosse Pointe Woods, 48236

ATTN: Beth Miro

Phone: 313-343-2456

Email: bmiro@gpwmi.us

TERMS: NET RECEIPT OF INVOICE

2% SERVICE CHARGE AFTER 30 DAYS

DELIVERY WILL BE MADE THIS DATE

WE WILL ADVISE OF UNAVOIDABLE DELAY

DELIVER TO

SAME

Contact:

SALESMAN

D. Tibaldo

Please Add 3% For
All Credit Card Paymen

| <u>Mfr.</u> | <u>Qty.</u> | <u>Piece No.</u> | <u>Item Description</u> | <u>Unit Price</u> | <u>Amount</u> |
|--|-------------|--------------------------------|--|-------------------|---------------|
| <u>Furniture & Flooring Renovaton For Court Offices</u> | | | | | |
| <u>Systems Furniture</u> | | | | | |
| LAC | 5 Pairs | KAPB-2 | <u>Panel brackets, pair</u> Color: Black | \$22.90 | \$114.50 |
| LAC | 4 Pairs | KACB-P-2 | <u>Standard cantilever brackets, pair</u> Color: Black | \$58.75 | \$235.00 |
| LAC | 5 Pairs | KACB-P-2 | <u>Shared cantilever brackets, pair</u> Color: Black | \$71.28 | \$356.40 |
| LAC | 2 | KEB3-S-6 | <u>3- Circ., Hardwire Base Feed</u> | \$116.64 | \$233.28 |
| LAC | 1 Pack | KER3-C1-W | <u>3-Circ., Duplex Receptacles</u> Circuit #1, White, Pack of 10 | \$144.72 | \$144.72 |
| LAC | 1 Pack | KER3-C2-W | <u>3-Circ., Duplex Receptacles</u> Circuit #2, White, Pack of 10 | \$144.72 | \$144.72 |
| LAC | 3 | KKAMB-12-42 | <u>White Board, 12 1/4H x 42W</u> Folded Metal. Magnetic. High-gloss White Finish For Dry-erase Markers. | \$114.05 | \$342.15 |
| LAC | 3 | KKATB-12-42 GR2 FG 09 | <u>Tackboard, 12 1/4H x 42W</u> Grade: 2 Fabric Pattern: Off The Grid Fabric Color: Tidal | \$190.51 | \$571.53 |
| Group | 1 | KMPM-1522-1 P17 | <u>Modular pedestal w/ metal fr., B/F, 17 7/8D</u> Size: 15 1/4W X 22D X 20 1/8"H Trim Color: Beige Under Reception Desk | \$302.40 | \$302.40 |

The Above Merchandise is Special Ordered and Not Subject to Cancellation

ALL MERCHANDISE SOLD SUBJECT TO AVAILABILITY

PURCHASER _____

Date _____

By _____

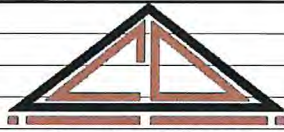

Creative Office Interiors, Inc.

25821 Jefferson Avenue

St. Clair Shores, Michigan 48081

(586) 445-6155

Fax (586) 445-6164

REFER TO THIS NO.
WHEN PHONING
SALES CONTRACT
NO. 6987
(PAGE 2 OF 7)

Date: December 12, 2022

CUSTOMER

City Of Grosse Pointe Woods

ADDRESS

20025 Mack Ave.

CITY

Grosse Pointe Woods, 48236

ATTN: Beth Miro

Phone: 313-343-2456

Email: bmiro@gpwmi.us

TERMS: NET RECEIPT OF INVOICE

2% SERVICE CHARGE AFTER 30 DAYS

DELIVERY WILL BE MADE THIS DATE _____

WE WILL ADVISE OF UNAVOIDABLE DELAY

DELIVER TO

SAME

CITY OR TOWNSHIP

Contact:

SALESMAN

D. Tibaudo

Please Add 3% For

All Credit Card Paymen

| Mfr. | Qty. | Piece No. | Item Description | Unit Price | Amount |
|---|-------------|--|---|------------|------------|
| <u>Systems Furniture (Cont.)</u> | | | | | |
| LAC | 3 | KMPF-1522-2 P17 | <u>Modular pedestal w/ metal fr., F/F, 21 7/8D</u> Trim Color: Beige | \$297.22 | \$891.66 |
| LAC | 4 | KMPF-1522-3 P17 | <u>Modular pedestal w/ metal fr., B/B/F, 21 7/8D</u> Trim Color: Beige | \$333.07 | \$1,332.28 |
| LAC | 4 Panels | KPMA-4224-3P P04 E6 1 E6 1 GR1 | <u>Acoust. panel, pwr. 3-circ., 42 1/4Hx24W</u> Trim And Base Color: Charcoal Selection For Base Panel - Side A: STRATUS - GR1 Panel Fabric Color: Tornado Selection For Base Panel - Side B: STRATUS - GR1 Panel Fabric Color: Tornado Grade Selected For The Panel Base: Grade 1 | \$304.99 | \$1,219.96 |
| LAC | 3 Panels | KPMA-4230-3P P04 E6 1 E6 1 GR1 | <u>Acoust. panel, pwr. 3-circ., 42 1/4Hx30W</u> Trim And Base Color: Charcoal Selection For Base Panel - Side A: STRATUS - GR1 Panel Fabric Color: Tornado Selection For Base Panel - Side B: STRATUS - GR1 Panel Fabric Color: Tornado Grade Selected For The Panel Base: Grade 1 | \$343.01 | \$1,029.03 |
| LAC | 4 Panels | KPMA-4242-3P P04 E6 1 E6 1 GR1 | <u>Acoust. panel, pwr. 3-circ., 42 1/4Hx42W</u> Trim And Base Color: Charcoal Selection For Base Panel - Side A: STRATUS - GR1 Panel Fabric Color: Tornado Selection For Base Panel - Side B: STRATUS - GR1 Panel Fabric Color: Tornado Grade Selected For The Panel Base: Grade 1 | \$408.67 | \$1,634.68 |

The Above Merchandise is Special Ordered and Not Subject to Cancellation

ALL MERCHANDISE SOLD SUBJECT TO AVAILABILITY

PURCHASER _____

Date _____

By _____



Creative Office Interiors, Inc.

REFER TO THIS NO.
WHEN PHONING
SALES CONTRACT
NO. 6987
(PAGE 3 OF 7)

Date: December 12, 2022

25821 Jefferson Avenue

CUSTOMER

St. Clair Shores, Michigan 48081

DELIVER TO

City Of Grosse Pointe Woods

(586) 445-6155

SAME

ADDRESS

Fax (586) 445-6164

ADDRESS

20025 Mack Ave.

CITY

CITY OR TOWNSHIP

Grosse Pointe Woods, 48236

ATTN: Beth Miro

NEAR MAIN INTERSECTION

Phone: 313-343-2456

Email: bmiro@gpwmi.us

TERMS: NET RECEIPT OF INVOICE

2% SERVICE CHARGE AFTER 30 DAYS

DELIVERY WILL BE MADE THIS DATE

SALESMAN

Please Add 3% For

WE WILL ADVISE OF UNAVOIDABLE DELAY

D. Tibaldo

All Credit Card Paymen

| <u>Mfr.</u> | <u>Qty.</u> | <u>Piece No.</u> | <u>Item Description</u> | <u>Unit Price</u> | <u>Amount</u> |
|---|-------------|------------------|--|-------------------|---------------|
| <u>Systems Furniture (Cont.)</u> | | | | | |
| LAC | 11 | KPMA-4242-NN | <u>Acoust. panel, non-pwr., 42 1/4Hx42W</u> | \$333.07 | \$3,663.77 |
| | Panels | P04 | Trim And Base Color: Charcoal | | |
| | | E6 | Selection For Base Panel - Side A: STRATUS - GR1 | | |
| | | 1 | Panel Fabric Color: Tornado | | |
| | | E6 | Selection For Base Panel - Side B: STRATUS - GR1 | | |
| | | 1 | Panel Fabric Color: Tornado | | |
| | | GR1 | Grade Selected For The Panel Base: Grade 1 | | |
| LAC | 3 | KUC-2442-K-1- | <u>Std. corner surf., TFL, grommet, Straight fr.,</u> | \$319.25 | \$957.75 |
| | Surfaces | G-D | 24Dx42W ; Laminate Selection: FOSSIL | | |
| | | FOS | | | |
| LAC | 3 | KUR-2430-1-G | <u>Std. rect. surf., TFL, grommet, 24Dx30W</u> | \$142.13 | \$426.39 |
| | Surfaces | FOS | Laminate Selection: FOSSIL | | |
| LAC | 3 | KUR-2442-1-G | <u>Std. rect. surf., TFL, grommet, 24Dx42W</u> | \$165.02 | \$495.06 |
| | Surfaces | FOS | Laminate Selection: FOSSIL | | |
| LAC | 5 | KUR-2484-1-G | <u>Std. rect. surf., TFL, grommet, 24Dx84W</u> | \$246.24 | \$1,231.20 |
| | Surfaces | FOS | Laminate Selection: FOSSIL | | |
| LAC | 6 | KVET-42 | <u>End-of-run trims, full height, 42 1/4H</u> | \$83.81 | \$502.86 |
| | Trims | P04 | Trim Color: Charcoal | | |
| LAC | 2 | KVPT-42 | <u>T junction kit, full height, 42 1/4H</u> | \$60.48 | \$120.96 |
| | Trim | P04 | Trim Color: Charcoal | | |
| LAC | 4 | KVPL-42 | <u>L junction kit, full height, 42 1/4H</u> | \$99.36 | \$397.44 |
| | Trim | P04 | Trim Color: Charcoal | | |

The Above Merchandise is Special Ordered and Not Subject to Cancellation

ALL MERCHANDISE SOLD SUBJECT TO AVAILABILITY

PURCHASER _____

Date _____

By _____

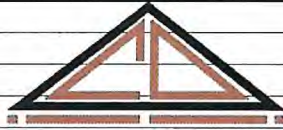

Creative Office Interiors, Inc.

25821 Jefferson Avenue

St. Clair Shores, Michigan 48081

(586) 445-6155

Fax (586) 445-6164

REFER TO THIS NO.
WHEN PHONING
SALES CONTRACT
NO. 6987
(PAGE 4 OF 7)

Date: December 12, 2022

CUSTOMER

City Of Grosse Pointe Woods

ADDRESS

20025 Mack Ave.

CITY

Grosse Pointe Woods, 48236

ATTN: Beth Miro

Phone: 313-343-2456

Email: bmiro@gpwmi.us

TERMS: NET RECEIPT OF INVOICE

2% SERVICE CHARGE AFTER 30 DAYS

DELIVERY WILL BE MADE THIS DATE _____

WE WILL ADVISE OF UNAVOIDABLE DELAY

DELIVER TO

SAME

ADDRESS

CITY OR TOWNSHIP

NEAR MAIN INTERSECTION

SALESMAN

D. Tibauda

Please Add 3% For

All Credit Card Payment

| Mfr. | Qty. | Piece No. | Item Description | Unit Price | Amount |
|---|----------|-----------------|--|------------|------------|
| <u>Systems Furniture (Cont.)</u> | | | | | |
| LAC | 3 | RIDFS-183028LF2 | <u>Metal lateral file, 2-high, 30"W, 18"D, 27 7/8"H.</u> Full Pull Regular Lock Lock Color: Sliver No Counterweight | \$616.52 | \$1,849.56 |
| | | STD P17 | Standard Offer Trim Color: Beige | | |
| LAC | 1 | RIDFS-183627LF2 | <u>2 Drawer Lateral File Fixed Front</u> Size: 36"W X 18"D X 26 7/8"H Full Pull Regular Lock Lock Color: Sliver | \$671.55 | \$671.55 |
| | | STD P17 | Standard Offer Trim Color: Beige Goes Under the Reception Desk | | |
| LAC | 1 | RINFS-361828B | <u>Metal Cabinet 2 High</u> Size: 36"W X 18"D X 27 7/8"H Full Pull Regular Lock Lock Color: Sliver | \$710.64 | \$710.64 |
| | | STD P17 | Standard Offer Trim Color: Beige <i>Goes Under Work Surface By Copier</i> | | |
| MOC | 1 | CH51-23S/86 | <u>Coat Rack With 4 Hooks</u> TORII RACK | \$156.50 | \$156.50 |
| MOC | 1 Lot | | <u>Freight For Above</u> | \$28.65 | \$28.65 |

The Above Merchandise is Special Ordered and Not Subject to Cancellation

ALL MERCHANDISE SOLD SUBJECT TO AVAILABILITY

PURCHASER _____

Date _____

By _____



REFER TO THIS NO.
WHEN PHONING
SALES CONTRACT
NO. 6987
(PAGE 5 OF 7)

Creative Office Interiors, Inc.

| | | |
|--|----------------------------------|-------------------------------|
| Date: December 12, 2022 | 25821 Jefferson Avenue | |
| CUSTOMER | St. Clair Shores, Michigan 48081 | DELIVER TO |
| City Of Grosse Pointe Woods | (586) 445-6155 | SAME |
| ADDRESS | Fax (586) 445-6164 | ADDRESS |
| 20025 Mack Ave. | | |
| CITY | | CITY OR TOWNSHIP |
| Grosse Pointe Woods, 48236 | | |
| ATTN: Beth Miro | | NEAR MAIN INTERSECTION |
| Phone: 313-343-2456 | | |
| Email: bmiro@gpwmi.us | | |
| TERMS: NET RECEIPT OF INVOICE | | |
| 2% SERVICE CHARGE AFTER 30 DAYS | | |
| DELIVERY WILL BE MADE THIS DATE | SALESMAN | Please Add 3% For |
| WE WILL ADVISE OF UNAVOIDABLE DELAY | D. Tibaudo | All Credit Card Paymen |

| <u>Mfr.</u> | <u>Qty.</u> | <u>Piece No.</u> | <u>Item Description</u> | <u>Unit Price</u> | <u>Amount</u> |
|--|-------------|------------------|---|-------------------|---------------|
| <u>Systems Furniture (Cont.)</u> | | | | | |
| WSI | 1 | | <u>Receive , Deliver & Install The Above Cubicles</u> | \$2,203.50 | \$2,203.50 |
| | Lot | | All Work Is To Be Completed In One Phase. Quoted As All Area To Be Clear Of Existing Furniture By Others. | | |
| <u>Systems Furniture Subtotal:</u> | | | | | |
| <u>\$21,968.14</u> | | | | | |
| <u>Electrostatic Spraying Of Existing Cabinets</u> | | | | | |
| PLX | 1 | | <u>Pick Up The Following File Cabinets:</u> | \$3,088.50 | \$3,088.50 |
| | Lot | | ** (2) 6 Drawer File Cabinets 36"W X 19"D X 41"H Remove Existing Tops On 2 Of The Above Cabinets That Are Glued To The Top Of The Cabinet, Sand & Electrostatically Spray. ** (1) 42"W X 19"D X 52 1/2"H Lateral File ** (1) 4 Dr. File Cabinet 30"W X 30 1/2"H Finish: Platinum Redeliver & Place Them During Millwork Installation. Note: All Drawers Must Be Emptied Prior To Pick Up. | | |
| <u>Millwork For Reception Counter</u> | | | | | |
| PLX | 1 | | <u>Remove Existing BR Glass & Existing</u> | \$15,537.60 | \$15,537.60 |
| | Lot | | Reception Desk/Counter. Install New Desk, Client Side & Office Side. Per Drawings. ReUse Existing BR Glass. If New Framework For BR Glass Is Necessary Additional Charges Will Apply. Includes (1) 36 X 19, (1) 42 X 19, & (1) 30 X 19 File Tops With Laminate Edge Laminate: Veranda Teak 8209K-28 Gloss Line Finish AEON Scratch Resistance | | |
| <u>Millwork & Electrostatic Spray Subtotal:</u> | | | | | |
| <u>\$20,829.60</u> | | | | | |

The Above Merchandise is Special Ordered and Not Subject to Cancellation

ALL MERCHANDISE SOLD SUBJECT TO AVAILABILITY

PURCHASER _____

Date _____

By _____



Creative Office Interiors, Inc.

REFER TO THIS NO.
WHEN PHONING
SALES CONTRACT
NO. 6987
(PAGE 6 OF 7)

| | | | | |
|--|--|----------------------------------|--|-------------------------------|
| Date: December 12, 2022 | | 25821 Jefferson Avenue | | |
| CUSTOMER | | St. Clair Shores, Michigan 48081 | | DELIVER TO |
| City Of Grosse Pointe Woods | | (586) 445-6155 | | SAME |
| ADDRESS | | Fax (586) 445-6164 | | ADDRESS |
| 20025 Mack Ave. | | | | |
| CITY | | | | CITY OR TOWNSHIP |
| Grosse Pointe Woods, 48236 | | | | |
| ATTN: Beth Miro | | | | NEAR MAIN INTERSECTION |
| Phone: 313-343-2456 | | | | |
| Email: bmiro@gpwmi.us | | | | |
| TERMS: NET RECEIPT OF INVOICE | | | | |
| 2% SERVICE CHARGE AFTER 30 DAYS | | | | |
| DELIVERY WILL BE MADE THIS DATE | | SALESMAN | | Please Add 3% For |
| WE WILL ADVISE OF UNAVOIDABLE DELAY | | D. Tibaudo | | All Credit Card Paymen |

| <u>Mfr.</u> | <u>Qty.</u> | <u>Piece No.</u> | <u>Item Description</u> | <u>Unit Price</u> | <u>Amount</u> |
|---------------------------------|----------------------|------------------|--|-------------------|---------------|
| <u>Flooring Material</u> | | | | | |
| JJ | 72 Yards | 7587 | <u>24" X 24" Modular Carpet Tiles</u> Style: 7587M Color: 2880 Armure Collection: Fractured Plaid Installation Method: Monolithic 8 Yards / Carton | \$39.35 | \$2,833.20 |
| JJ | 1 (4 Gallon Pail) | Nexus A1334 | <u>Carpet Adhesive</u> Cartoned In 4-Gallon Pails | \$162.50 | \$162.50 |
| JJ | 1 Lot | | <u>Freight For Above</u> | \$117.38 | \$117.38 |
| BLK ROP | 1 Ctns. | C45C83P139 | <u>4 1/2" Vinyl Cove Base</u> Roppe Base Color: 139 Deep Navy 120 Lin Ft/Ctn. Roll Goods | \$174.94 | \$174.94 |
| Blakel | 1 Lot | | <u>Freight Charges For Above Vinyl Base</u> | \$75.00 | \$75.00 |
| <u>Flooring Labor</u> | | | | | |
| CW | 70 Yards | | <u>Installation Of 24" X 24" Carpet Tiles</u> Glued Direct | \$5.63 | \$394.10 |
| CW | 70 Yards | | <u>Rip Existing Carpet</u> | \$3.13 | \$219.10 |
| CW | 70 Yards | | <u>Dispose Of Existing Carpet</u> | \$1.63 | \$114.10 |

The Above Merchandise is Special Ordered and Not Subject to Cancellation

ALL MERCHANDISE SOLD SUBJECT TO AVAILABILITY

PURCHASER _____

Date _____

By _____



Creative Office Interiors, Inc.

25821 Jefferson Avenue

St. Clair Shores, Michigan 48081

(586) 445-6155

Fax (586) 445-6164

REFER TO THIS NO.
WHEN PHONING
SALES CONTRACT
NO. 6987
(PAGE 7 OF 7)

Date: December 12, 2022

CUSTOMER

City Of Grosse Pointe Woods

ADDRESS

20025 Mack Ave.

CITY

Grosse Pointe Woods, 48236

ATTN: Beth Miro

Phone: 313-343-2456

Email: bmiro@gpwmi.us

TERMS: NET RECEIPT OF INVOICE

2% SERVICE CHARGE AFTER 30 DAYS

DELIVERY WILL BE MADE THIS DATE _____

WE WILL ADVISE OF UNAVOIDABLE DELAY

DELIVER TO

SAME

ADDRESS

CITY OR TOWNSHIP

NEAR MAIN INTERSECTION

SALESMAN

D. Tibaudo

Please Add 3% For
All Credit Card Paymen

| <u>Mfr.</u> | <u>Qty.</u> | <u>Piece No.</u> | <u>Item Description</u> | <u>Unit Price</u> | <u>Amount</u> | |
|--|-----------------|------------------|--|---------------------------|---------------------|-------------|
| Flooring Labor (Cont.) | | | | | | |
| CW | 630 Sq. Ft. | | <u>Skimcoating Floor</u> <i>Per Manufacturer's Specifications</i> | \$0.94 | \$592.20 | |
| CW | 105 Lin. Ft. | | <u>Installation Of 4 1/2" Vinyl Cove Base</u> For Areas With Non-Pattern Carpet | \$1.06 | \$111.30 | |
| CW | 105 Lin. Ft. | | <u>Rip & Disposal Of 4 1/2" Vinyl Cove Base</u> | \$0.56 | \$58.80 | |
| CW | 1 Lot | | <u>Gas Surcharge</u> | \$120.00 | \$120.00 | |
| | | | | Flooring Subtotal: | | |
| | | | | \$4,972.62 | | |
| <p><i>All Work Is Quoted To Be Done During Standard Business Hours Monday - Friday 8:30AM - 5:00PM If Non-Standard Hours Are Required Additional Charges May Apply. No Furniture Move.</i></p> <p><i>Any Additional Floor Prep Or Floor Prep Materials Will Be Charged Separately.</i></p> | | | | | | |
| A 50% DEPOSIT IS REQUIRED TO PROCESS ORDER | | | | | | |
| \$22,783.43 | | | | | | |
| | | | | | Subtotal: | \$45,566.86 |
| | | | | | No Taxes: | \$0.00 |
| | | | | | Grand Total: | \$45,566.86 |

The Above Merchandise is Special Ordered and Not Subject to Cancellation

ALL MERCHANDISE SOLD SUBJECT TO AVAILABILITY

PURCHASER _____

Date _____

By _____



CREATIVE OFFICE INTERIORS, INC.

25821 Jefferson Ave. ■ St. Clair Shores, Michigan 48081 ■ Phone (586) 445-6155 ■ Fax (586) 445-6164

TERMS & CONDITIONS SALES CONTRACT#6987 (\$45,566.86)

50% DEPOSIT IS REQUIRED TO PROCESS ORDER; BALANCE DUE UPON FINAL INVOICE

1. Creative Office Interiors, Inc. hereby agrees to sell, and Purchaser hereby agrees to purchase the merchandise noted on the reverse side, for which Purchaser agrees to pay seller according to the terms specified on the reverse side.
2. It is agreed that said merchandise may remain in the possession of Purchaser, but that title to said merchandise shall remain in Creative Office Interiors, Inc. until the same is fully paid for.
3. In the event that any installment shall not have been paid within ten days after it becomes due and payable, Purchaser agrees to pay a late charge of .08 cents per dollar in addition to the regular installment, or such lesser charge as may be permitted by law.
4. Creative Office Interiors, Inc. will warehouse for 30 days at no charge, thereafter a \$1.65 per square foot per month charge will be incurred. Delivery of merchandise shall occur within 15 days.
5. In the event construction delays or other causes not within Creative Office Interiors, Inc. control force postponement of the delivery and/or installation, the merchandise can be stored until installation will take place and will be considered accepted by the Purchaser for purposes of payment. Any storage charges incurred shall be paid by the Purchaser, starting 30 days after merchandise is ready for delivery.
6. When partial deliveries are made, the Purchaser will be invoiced for merchandise delivered. No payment can be withheld by Purchaser because of partial delivery on the entire order.
7. The Purchaser agrees to submit to Creative Office Interiors, Inc. any credit information requested in order to properly approve this order. Creative Office Interiors, Inc. reserves the right to change or cancel the terms of this order based on the credit rating and information obtained. Creative Office Interiors, Inc. also reserves the right to refuse this order for placement until any additional credit information or guarantee of payment is obtained from Purchaser, if required. The Purchaser warrants that the credit application and other financial statements submitted to Creative Office Interiors, Inc. are true and correct.
8. This order may not be canceled unless agreed to by the Purchaser and Management of Creative Office Interiors, Inc., in writing. If the cancellation of the order causes a restocking fee from the manufacturer, the Purchaser may be billed for the restocking charge by Creative Office Interiors, Inc. Custom furniture is not subject to cancellation.
9. All applicable taxes apply to all orders.
10. Delivery and installation will be made during normal business hours. Purchaser will be billed for any additional labor costs resulting from overtime work performed.
11. Creative Office Interiors, Inc. reserves and Purchaser grants a security interest in the merchandise described in the Agreement until payment has been received in full. Purchaser agrees to protect Creative Office Interiors, Inc. title and to keep merchandise free and clear of all claims and liens until Creative Office Interiors, Inc. has been paid in full.
12. Creative Office Interiors, Inc. shall not be responsible for manufacturer's inability to meet their estimated ship dates. Estimated ship dates are for manufacturer's time allowances only and do not include any time allowance for actual shipping and delivery of merchandise.
13. Purchaser must keep the job site free and clear of debris before and during the installation. Hoisting or elevator service and adequate facilities for offloading, staging, moving and handling of merchandise must be provided by the Purchaser and without charge to Creative Office Interiors, Inc. Purchaser is also responsible for securing necessary building permits and licenses.
14. Purchaser shall be solely responsible for any damage to or loss of merchandise after delivery.
15. Creative Office Interiors, Inc. assigns all rights derived from the manufacturer's warranties to the Purchaser to the extent such rights are assignable.
16. If the Purchaser fails to make any payment when due, or in the event of his non-performance of any of the terms or conditions of this contract by him to be performed, or removal of the merchandise from the place to which delivered without the Seller's written consent, or in the event of theft, conversion, destruction or other loss of all or part of said merchandise, or in the event of theft, conversion, destruction, or other loss of all or part of said merchandise, or in the event said merchandise shall come in the hands of any other person or officers by legal process or otherwise, the Seller may at its option, without notice, either declare the unpaid balance of the purchase price immediately due and payable or may rescind this contract to sell and take possession of the merchandise with or without legal process, wherever situated and without notice.
17. In the event of such repossession all payments theretofore made shall be retained by the seller as its property as and for the use and rental of said merchandise and as liquidated damages for the breach of this contract.
18. If the Purchaser has balances due on their contracts with the Seller, payments made by Purchaser may be applied pro rata on all such pending contracts.
19. It is further agreed that any extension of time of any payments hereunder, or failure of the Seller to promptly exercise any of its rights hereunder, shall not operate as a waiver of any of the Seller's rights under this contract, and that in the event Seller shall be compelled to pay or become liable for any attorney's fees or other expenses in connection with the enforcement of this contract, Purchaser will repay to Seller the amount of such fees, costs and expenses.
20. Purchaser agrees to pay attorney's fee and costs incurred by Creative Office Interiors, Inc. in enforcement of terms of this agreement, including but not limited to payment and realization on the security interest granted herein.
21. The above is the entire agreement between the Purchaser and Creative Office Interiors, Inc. It may not be changed without mutual written authorization.

Company: _____ Purchaser: _____ Date: _____

Furniture Renovation
For Court Offices

Paradigm Collection

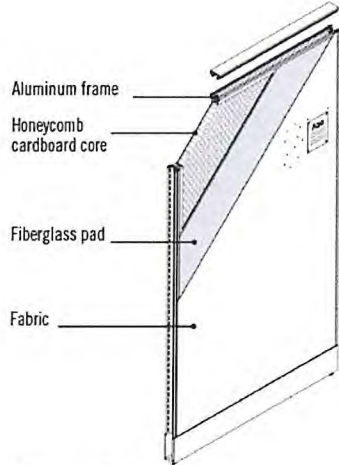

Fabric acoustical panel



Finishes

Lateral File Cabinets



Box / box / file



File / file



Work Surfaces

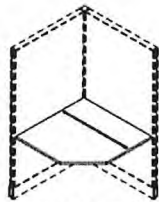
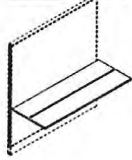

Straight front (K)

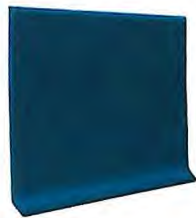

4 1/2" Vinyl Cove Base
Color: Deep Navy



Panel Fabric Color:
Tornado



Panel Trim Metal Finish:
Charcoal



Carpet Color:
Armure



Work Surface
Laminate Finish:
Fossil

**Furniture Renovation For Court
Offices**

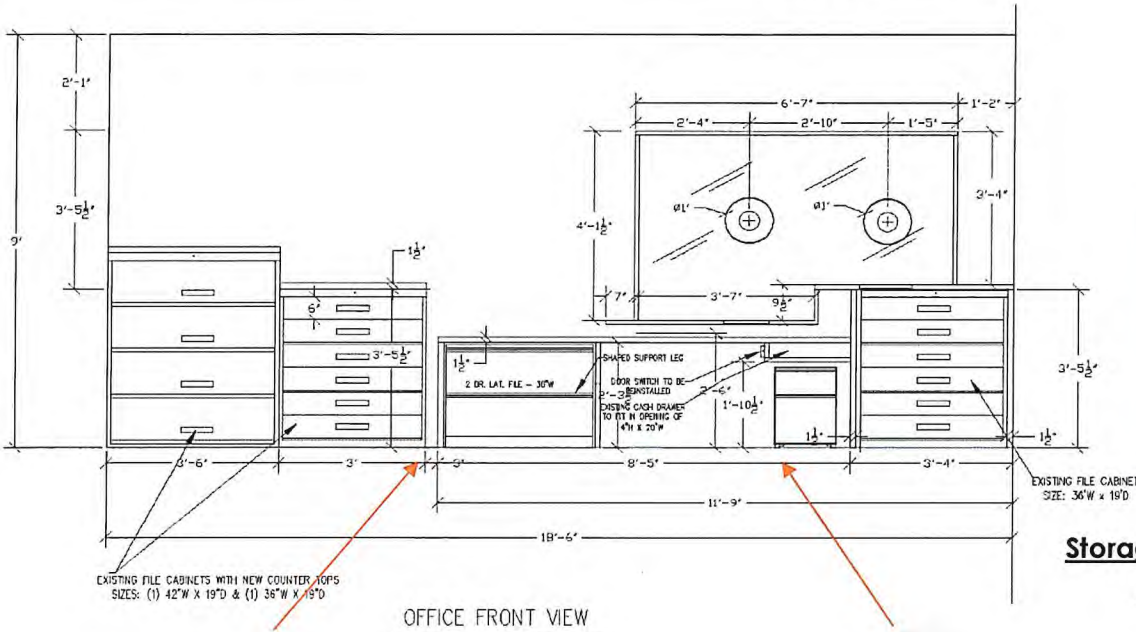

**Storage Cabinets Metal
Finish: Beige**



**36" Wide Lateral
File Cabinet**



**Under Cash Box
Storage Cabinet**

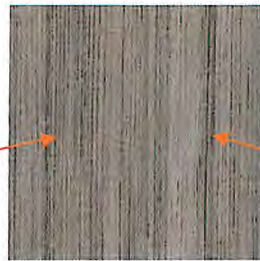
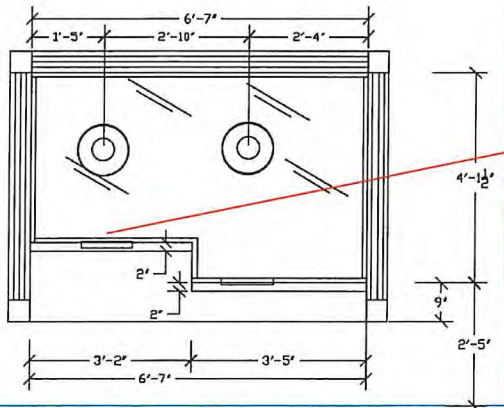

**Bow Counter Laminate
Finish: Veranda Teak**

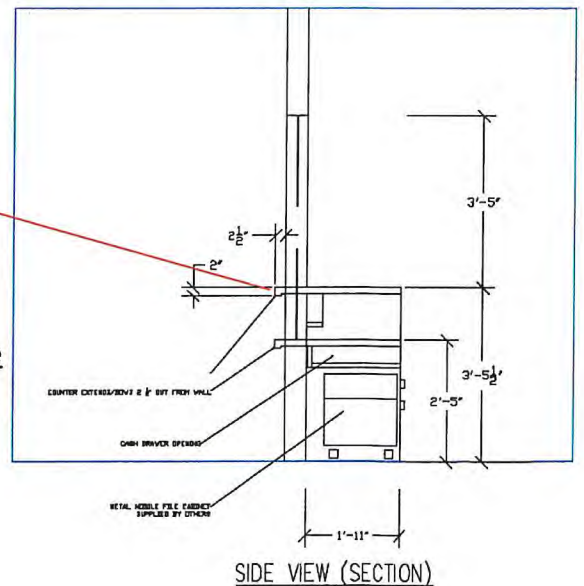



**Storage Cabinet By
The Copier**



Storage Cabinets Metal

Finish: Beige (Electrostatic Files Will Be Sprayed To Match)

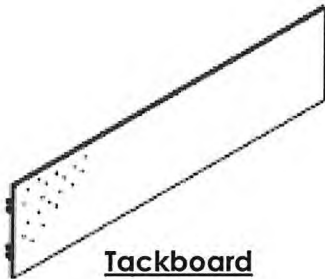

Tackboard



Tackboard Fabric:

pattern: Off The Grid
Color: Tidaal

Whiteboard



Coat Rack



Furniture Renovation
For Court Offices

Renderings



Furniture Renovation
For Court Offices

Renderings



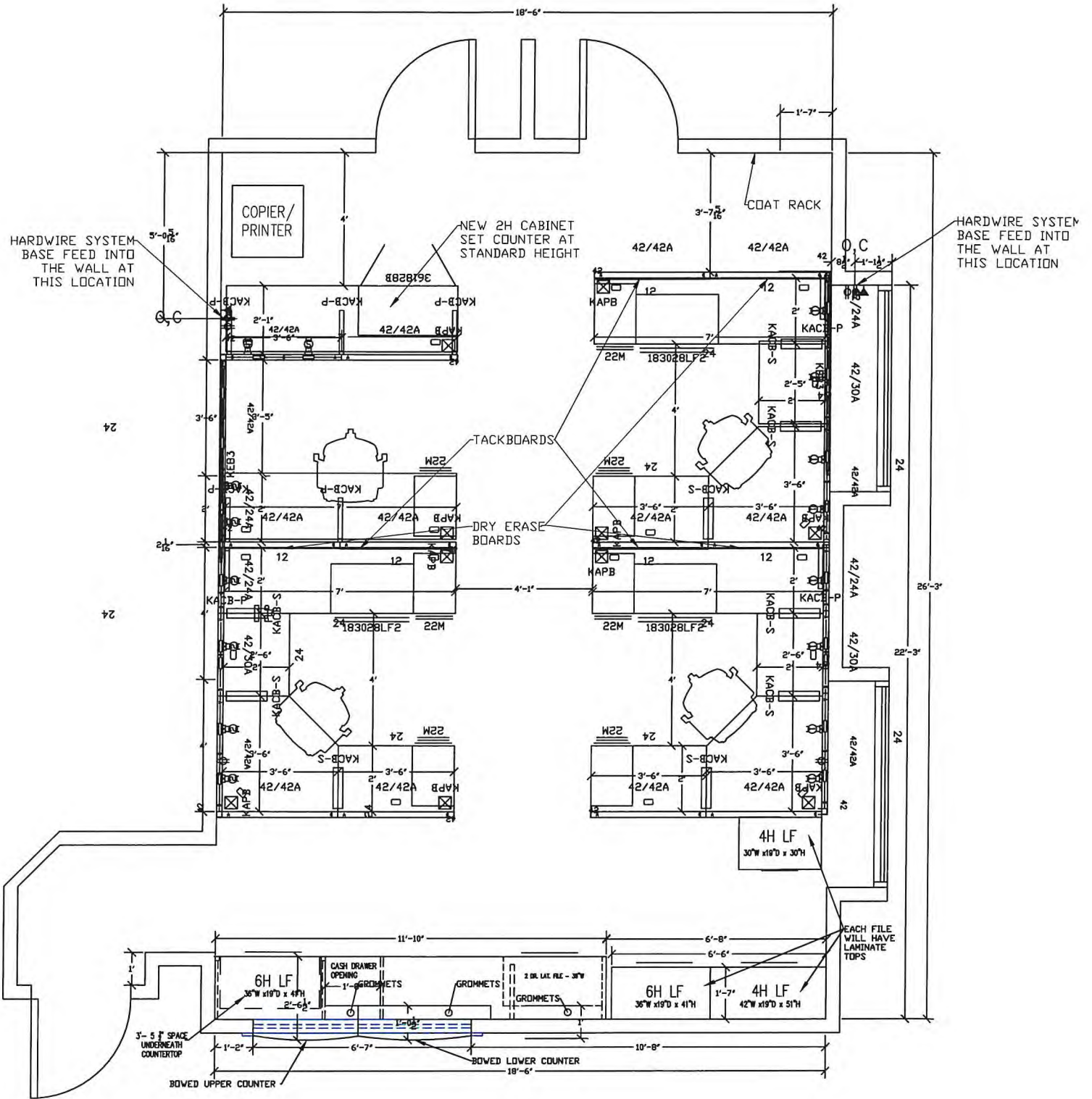

CLIENT: CITY OF GROSSE POINTE WOODS
 20025 MACK PLAZA DRIVE, GROSSE POINTE WOODS, MI 48236

PROJECT: RENOVATIONS

SHEET NAME:

FLOOR PLAN

DATE:

12/12/22

PAGE:

1 OF 2

ALL DRAWINGS ARE PROPERTY OF CREATIVE OFFICE INTERIORS.
 THEY CANNOT BE REUSED WITHOUT WRITTEN PERMISSION AND ADDITIONAL
 COMPENSATION

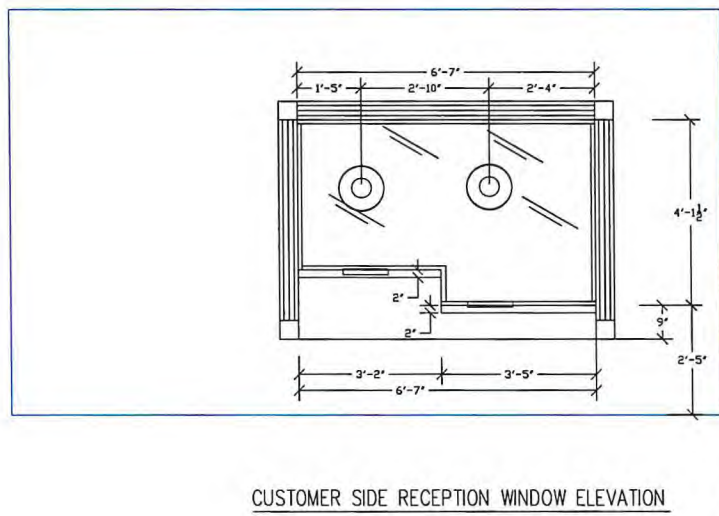
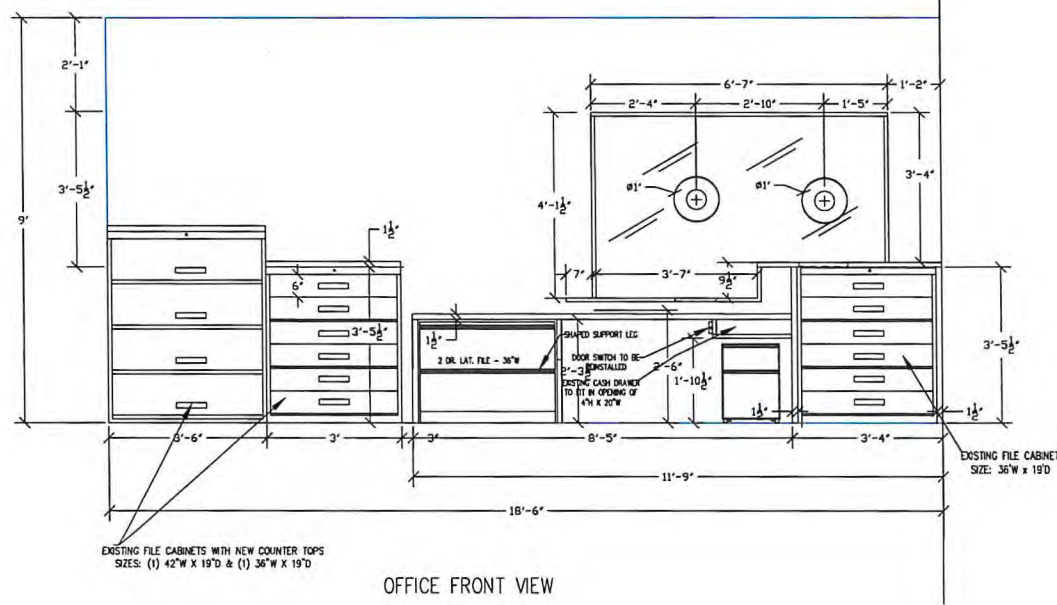
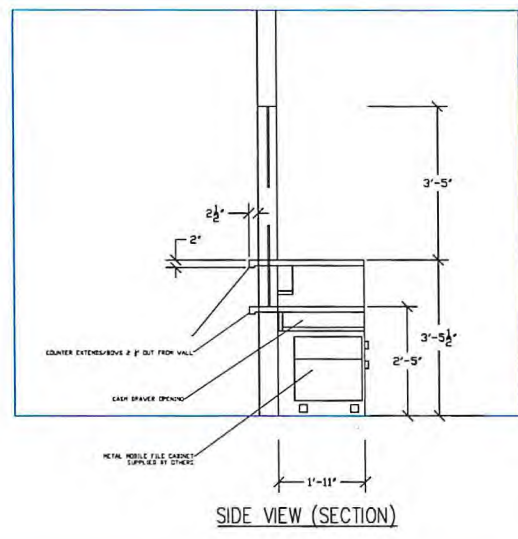
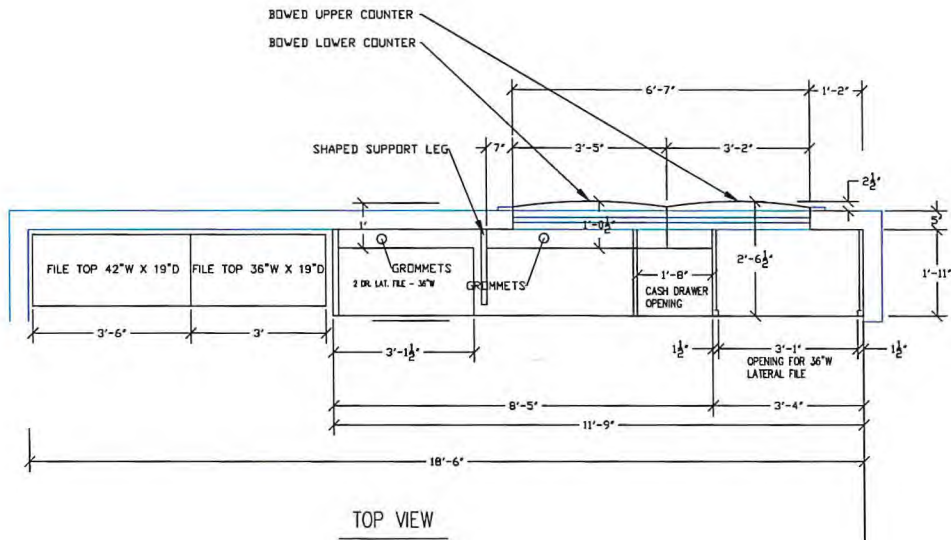

| | | | | |
|---|----------------------|---|----------------|--------------|
| CLIENT: CITY OF GROSSE POINTE WOODS 2005 MACK PLAZA DRIVE, Grosse Pointe Woods, MI 48236 | PROJECT: RENOVATIONS | SHEET NAME: Elevations | DATE: 12/12/22 | PAGE: 2 OF 2 |
| | | ALL DRAWINGS ARE PROPERTY OF CREATIVE OFFICE INTERIORS. THEY CANNOT BE REPRODUCED WITHOUT WRITTEN PERMISSION AND ADDITIONAL COMPENSATION. | | |
|  CREATIVE OFFICE INTERIORS, INC. | | | | |