

SNOW MAKERS

# ON-BOARD BOOSTER PUMP



# Your Solution to Low Water Pressure

With our On-Board Booster Pump, you can boost snowmaking pressure from 40-120 psi to optimal pressures. This pump is perfect for venues with lower operating water pressure, such as parks or resorts with older infrastructure.

---

## System Includes

- Manual or Automatic Standard or Kid Polecat configuration.
- 15 HP Booster Pump.
- Heated cover to insulate and protect the pump.
- 3 wheel galvanized steel carriage w/ Snowcat lifting brackets.
- Spring-loaded drain allows the operator to avoid manual drainage.

---

## Specs

- **Fan:** 15 HP (11 kW) or 10 HP (7.5 kW)
- **Fan Speed:** 1760 rpm at 480V/60Hz or 1450 rpm at 400V/50Hz
- **Compressor:** 5 HP or 10 HP Hydrovane
- **Heating:** 225 W
- **Spray Manifold Heater:** 1,300 W (480V/60Hz)
- **Water Pressure:** minimum 40 psi and maximum 120 psi inlet water pressure to the booster pump.
- **Valves:**
  - Standard Polecat: 3 self-draining heated 3-way valves
  - Kid Polecat: 2 self-draining heated 3-way valves
- **Nucleators:** Central nozzle with six jets
- **Filtration system:** stainless steel filter with a washable 30 or 60 mesh screen
- **Positioning:** 360° horizontal rotation, -10° to 60° elevation adjustment
- **Oscillator:** automatic 70° arc of rotation



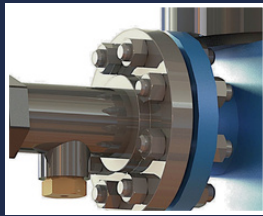

### Drain Valve

Drain valve is connected to the bottom of the Booster Pump which automatically drains water during operations.

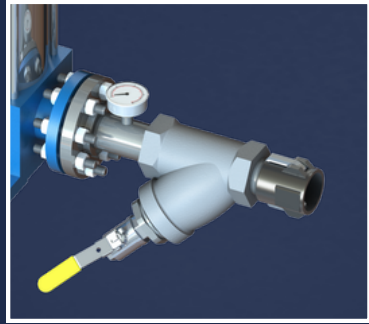

### Wye Line Water Filter

Additional water filter for dirty water and easy maintenance.

### Heated Cover

The Booster Pump comes with a heated cover to insulate and protect the pump.

# Standard Polecat with Booster Pump Specs

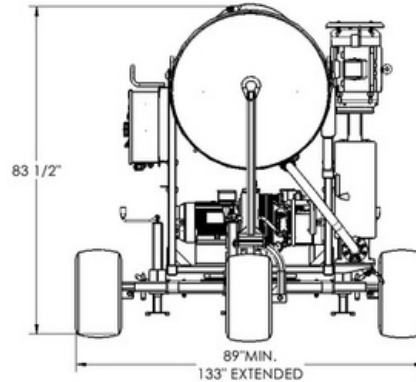
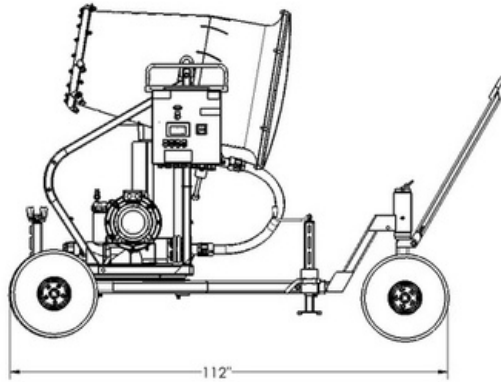

## Electrical

- Voltage: 480V
- Frequency: 60 Hz
- Current: 34 A
- Heating: 225 W

## Power

- Fan: 10 HP or 15 HP
- Compressor: 5 HP or 10 HP
- Pump: 15 HP

## Weight (lbs)

- Standard Polecat (10 HP): 2,264 lbs
- Standard Polecat (5 HP): 2,153 lbs

## Operation

- Rotational Fan Speed: 1,800 RPM
- Turbine Inclination: 45°
- Oscillation: 35 deg (optional)

## Water

- Operating Pressure
  - 40 psi minimum to 120 psi maximum inlet pressure
- Boost Pressure:
  - Up to 450 psi boost at minimum flow
  - Up to 250 psi boost at maximum flow
- Water Filter: 30 or 60 mesh

## Nozzles

- Nucleator: Single 6-Jet Center Nucleator
- Manual Standard Polecat:
  - Always On Nozzles: 6
  - Switchable Nozzles: 12
  - *Total Nozzles: 18*
- Automatic Standard Polecat:
  - Always On Nozzles: 6
  - Switchable Nozzles: 12
  - *Total Nozzles: 18*

# Kid Polecat with Booster Pump Specs

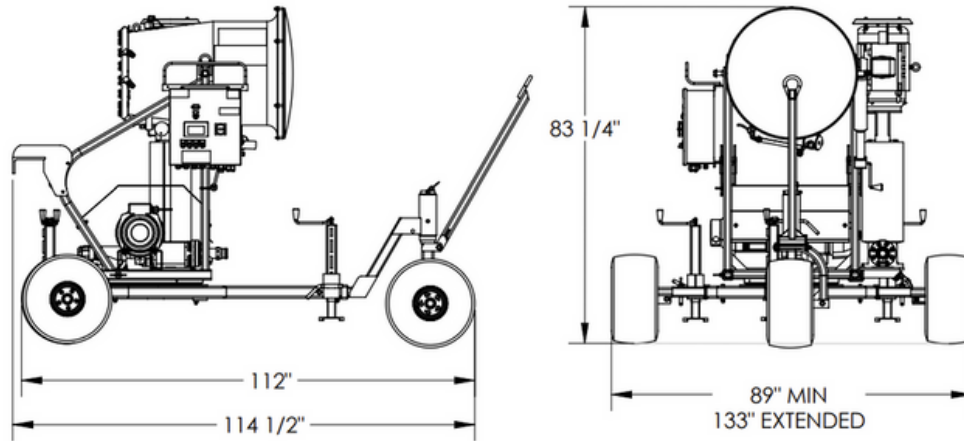

## Electrical

- Electrical: Three phase
- Heating: 250W
  - Optional spray nozzle heater (500-1300 W)

## Power

- Fan: 7.5 HP
- Compressor: 5 HP
- Pump: 15 HP

## Weight (lbs)

- Kid Polecat (10 HP): 2,100 lbs
- Kid Polecat (5 HP): 1,989 lbs

## Operation

- Rotational Fan Speed: 1,800 RPM
- Turbine Inclination: 45°
- Oscillation: 35 deg

## Water

- Operating Pressure
  - 40 psi minimum to 120 psi maximum inlet pressure
- Boost Pressure:
  - Up to 450 psi boost at minimum flow
  - Up to 250 psi boost at maximum flow
- Water Filter: 30 mesh

## Nozzles

- Nucleator: Single 6-Jet Center Nucleator
- Manual and Automatic Kid Polecat:
  - Always On Nozzles: 6
  - Switchable Nozzles: 12
  - *Total Nozzles: 18*



Ready to start? Let's build your  
system.

**Snow Machines Inc.**  
www.snowmakers.com  
1512 Rockwell Dr, Midland, MI 48642  
P : 1 (989) 631 -6091

