

## **ATTACHMENTS**

### **Pine Creek Shopping Center**

#### **Master Sign Program Amendments**

1. Vicinity Map
2. Aerial Map
3. Universal Application
4. Master Sign Program Application
5. Proposed Master Sign Program Amendments (redlined)

# Vicinity Map - Pine Creek Shopping Center

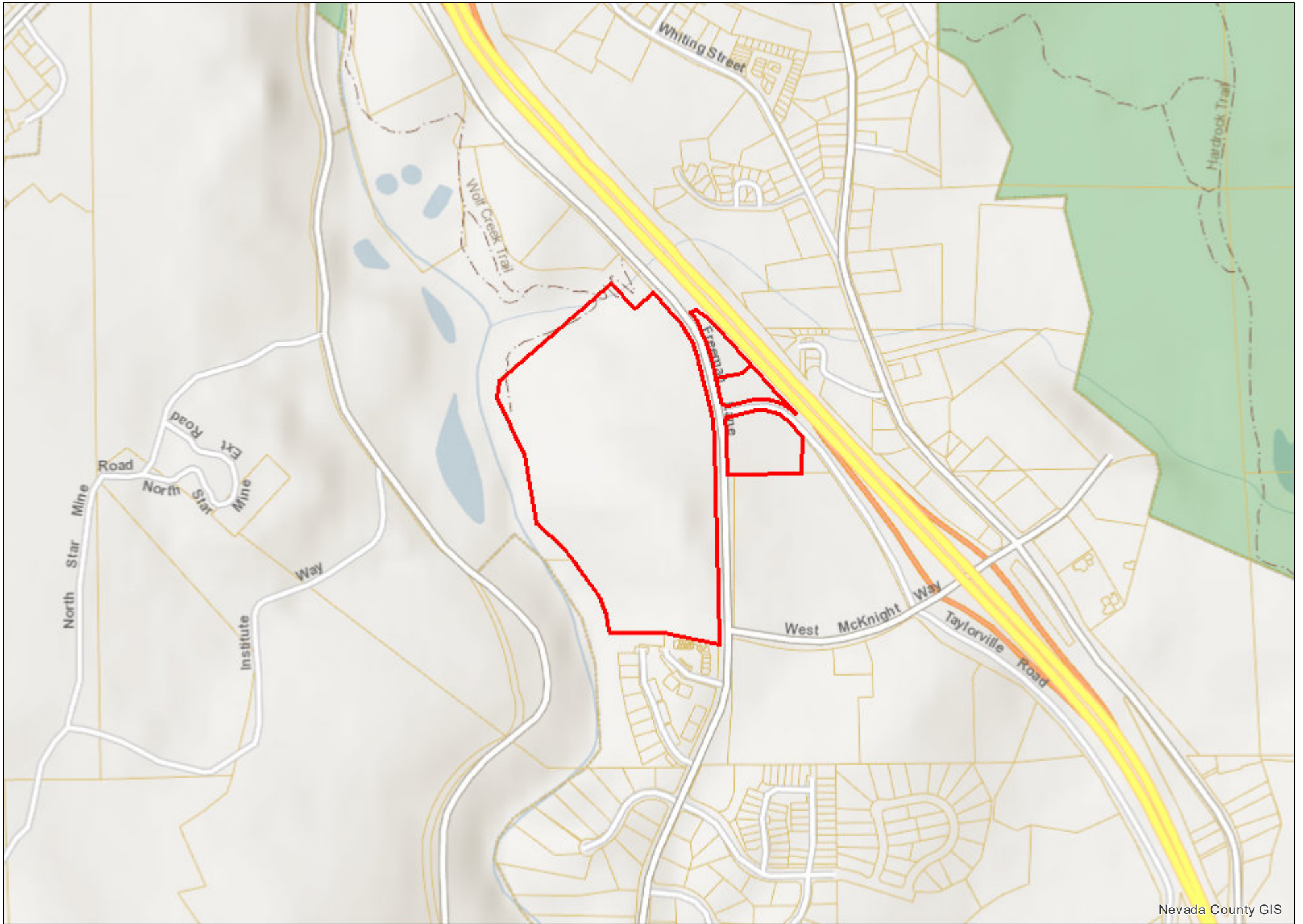

Nevada County GIS

# Aerial Map - Pine Creek Shopping Center



Nevada County GIS

January 22, 2025

© 2024 Nevada County, California

Scale:  
1:9,028

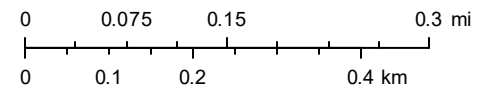

# UNIVERSAL PLANNING APPLICATION



## Application Types

### Administrative

- Limited Term Permit  
\$757.00
- Zoning Interpretation  
\$243.00

### Development Review

- Minor Development Review – under 10,000 sq. ft.  
\$1,966.00
- Major Development Review – over 10,000 sq. ft.  
\$3,571.00
- Conceptual Review - Minor  
\$497.00
- Conceptual Review – Major  
\$847.00
- Plan Revisions – Staff Review  
\$342.00
- Plan Revisions – DRC / PC Review  
\$901.00
- Extensions of Time – Staff Review  
\$306.00
- Extensions of Time – DRC / PC Review  
\$658.00

### Entitlements

- Annexation  
\$8,505.00 (deposit) + \$20.00 per acre
- Condominium Conversion  
\$5,339.00 (deposit) + \$25 / unit or \$25 / 1,000 sf com.
- Development Agreement – New  
\$20,023.00 (deposit) + cost of staff time & consultant minimum \$300
- Development Agreement – Revision  
\$7,486.00 + cost of staff time & consultant minimum \$300
- General Plan Amendment  
\$8,000.00
- Planned Unit Development  
\$8,839.00 + \$100.00 /unit and / or \$100 / 1,000 sf floor area
- Specific Plan Review - New  
Actual costs - \$18,399.00 (deposit) (+ consultant min. \$300)
- Specific Plan Review - Amendments / Revisions  
Actual costs - \$7,576.00 (deposit) (+ consultant min. \$300)
- Zoning Text Amendment  
\$3,364.00
- Zoning Map Amendment  
\$5,501.00
- Easements (covenants & releases)  
\$1,794.00

### Environmental

- Environmental Review – Initial Study  
\$1,858.00
- Environmental Review – EIR Preparation  
Actual costs - \$34,274.00 (deposit)
- Environmental Review - Notice of Determination  
\$162.00 (+ Dept. of Fish and Game Fees)

- Environmental Review - Notice of Exemption  
\$162.00 (+ County Filing Fee)

### Sign Reviews

- Minor – DRC, Historic District, Monument Signs or other districts having specific design criteria  
\$330.00
- Major – Master Sign Programs  
\$1,407.00
- Exception to Sign Ordinance  
\$1,046.00

### Subdivisions

- Tentative Map (4 or fewer lots)  
\$3,788.00
- Tentative Map (5 to 10 lots)  
\$5,267.00
- Tentative Map (11 to 25 lots)  
\$7,053.00
- Tentative Map (26 to 50 lots)  
\$9,668.00
- Tentative Map (51 lots or more)  
\$14,151.00
- Minor Amendment to Approved Map (staff)  
\$1,208.00
- Major Amendment to Approved Map (Public Hearing) \$2,642.00
- Reversion to Acreage  
\$829.00
- Tentative Map Extensions  
\$1,136.00
- Tentative Map - Lot Line Adjustments / Merger  
\$1,325.00

### Use Permits

- Minor Use Permit - Staff Review  
\$562.00
- Major Use Permit - Planning Commission Review  
\$3,292.00

### Variances

- Minor Variance - Staff Review  
\$562.00
- Major Variance - Planning Commission Review  
\$2,200.00

<u>Application</u>	<u>Fee</u>
Plan Revisions - DRC/PC Review	<b>901.00</b>
<b>Total:</b>	<b>\$901.00</b>

692 Freeman Ln, Grass Valley, CA 95949

Below is the Universal Planning Application form and instructions for submitting a complete planning application. In addition to the Universal Planning Application form, a project specific checklist shall be submitted. All forms and submittal requirements must be completely filled out and submitted with any necessary supporting information.

Upon receipt of the **completed forms, site plan/maps, and filing fees**, the Community Development Department will determine the completeness of the application. This review will be completed as soon as possible, but within thirty (30) days of the submittal of the application. If the application is determined to be complete, the City will begin environmental review, circulate the project for review by agencies and staff, and then schedule the application for a hearing before the Planning Commission.

If sufficient information **has not** been submitted to adequately process your application, you will receive a notice that your application is incomplete along with instructions on how to complete the application. Once the City receives the additional information or revised application, the thirty (30) day review period will begin again.

Since the information contained in your application is used to evaluate the project and in the preparation of the staff report, it is important that you provide complete and accurate information. Please review and respond to each question. If a response is not applicable, N/A should be used in the space provided. Failure to provide adequate information could delay the processing of your application.

Additional information may be obtained at [www.cityofgrassvalley.com](http://www.cityofgrassvalley.com) regarding the 2020 General Plan and Zoning. You may also contact the Community Development Department for assistance.

### **ADVISORY RE: FISH AND GAME FEE REQUIREMENT**

Permit applicants are advised that pursuant to Section 711.4 of the Fish and Game Code a fee of **\$3,445.25** for an Environmental Impact Report and **\$2,480.25** for a Negative Declaration\* shall be paid to the County Recorder at the time of recording the Notice of Determination for this project. This fee is required for Notices of Determination recorded after January 1, 1991. A Notice of Determination cannot be filed and any approval of the project shall not be operative, vested, or final until the required fee is paid. This shall mean that building, public works and other development permits cannot be approved until this fee is paid. These fees are accurate at the time of printing, but **increase the subsequent January 1<sup>st</sup>** of each year.

This fee is **not** a Grass Valley fee; it is required to be collected by the County pursuant to State law for transmission to the Department of Fish and Game. This fee was enacted by the State Legislature in September 1990, to be effective January 1, 1991.

\*If the City finds that the project will not have an impact on wildlife resources, through a De Minimus Impact Finding, the City will issue certificate of fee exemption. Therefore, this fee will not be required to be paid at the time an applicant files the Notice of Determination with the County Recorder. The County's posting and filing fees will still be required.



4. **Cortese List:** Is the proposed property located on a site which is included on the Hazardous Waste and Substances List (Cortese List)? Y  N

The Cortese List is available for review at the Community Development Department counter. If the property is on the List, please contact the Planning Division to determine appropriate notification procedures prior to submitting your application for processing (Government Code Section 65962.5).

5. **Indemnification:** The City has determined that City, its employees, agents and officials should, to the fullest extent permitted by law, be fully protected from any loss, injury, damage, claim, lawsuit, expense, attorney's fees, litigation expenses, court costs or any other costs arising out of or in any way related to the issuance of this permit, or the activities conducted pursuant to this permit. Accordingly, to the fullest extent permitted by law, the applicant shall defend, indemnify and hold harmless City, its employees, agents and officials, from and against any liability, claims, suits, actions, arbitration proceedings, regulatory proceedings, losses, expenses or costs of any kind, whether actual, alleged or threatened, including, but not limited to, actual attorney's fees, litigation expenses and court costs of any kind without restriction or limitation, incurred in relation to, as a consequence of, arising out of or in any way attributable to, actually, allegedly or impliedly, in whole or in part, the issuance of this permit, or the activities conducted pursuant to this permit. Applicant shall pay such obligations as they are incurred by City, its employees, agents and officials, and in the event of any claim or lawsuit, shall submit a deposit in such amount as the City reasonably determines necessary to protect the City from exposure to fees, costs or liability with respect to such claim or lawsuit.
6. **Appeal:** Permits shall not be issued until such time as the appeal period has lapsed. A determination or final action shall become effective on the 16<sup>th</sup> day following the date by the appropriate review authority, where no appeal of the review authority's action has been filed in compliance with Chapter 17.91 of the City's Development Code.

The 15-day period (also known as the "appeal" period in compliance with Chapter 17.91) begins the first full day after the date of decision that the City Hall is open for business, and extends to the close of business (5:00 p.m.) on the 15<sup>th</sup> day, or the very next day that the City Hall is open for business.

I hereby certify, to the best of my knowledge, that the above statements are correct.

Property Owner/\*Representative Signature: 

**\*Property owner must provide a consent letter allowing representative to sign on their behalf.**

Applicant Signature: 

-OFFICE USE ONLY-	
Application No.:	Date Filed:
Fees Paid by:	Amount Paid:
Other Related Application(s):	

# MASTER SIGN PROGRAM MURALS & SIGN EXCEPTIONS



## SUPPLEMENTAL APPLICATION INFORMATION

**Application Request:** Ammend existing Master Signage Program which is 40 years old and in need of updating to conform to current technology, branding and practice.

---

---

**Property Address or Location:** 692 Freeman Ln, Grass Valley, CA 95949

---

---

## SUPPLEMENTAL CHECKLIST

The following includes items required for a complete application. Some specific types of information may not apply to your project. If you are unsure, check with Planning Division Staff. A copy of this list will be returned to you if your application is determined to be incomplete.

---

---

### A. Application Checklist:

- One completed copy of Universal Application form.
- One completed copy of the Environmental Review Checklist (if applicable).
- One electronic copy of the site plan and all other applicable plans/information.
- One materials sample board (if applicable).
- If a sign exemption is being requested, list the reasons for the exemption.
- The appropriate non-refundable filing fee.

### B. Site Plan:

- SITE PLAN; On electronic copy of the Site Plan for the property on which the sign(s) will be placed including:
- Location of existing and proposed signs on site.
- Provide square footage and type of each sign and total square footage for all signs.
- For more than one sign, please give each sign a number starting with the number 1.
- For suspended or projecting signs please note distance from sidewalk to bottom of sign.



- For wall signs add an additional sheet showing dimensions and square footage of building walls on which signs will be placed.
- For monument, shopping center, or other freestanding signs show sight distance from driveways and intersection corners.

**C. Sign Illustrations:**

- Color drawing of each proposed sign including:
- Number each sign corresponding to number shown on the site plan.
- Message on sign including; typeface, font, and design details.
- Dimensions in feet and total square footage area of proposed sign.
- Overall height of all monument and freestanding signs.

**D. Murals:** A mural placed on a wall of a structure may be allowed in any commercial, industrial, and other non-residential zone subject to the following requirements. All murals shall be subject to the review and recommendation by the Development Review Committee (DRC) and approval by the Commission.

- A mural without text visible from the public right-of-way may be approved in addition to (not counted as part of) the sign area allowed by the Development Code; a mural with text shall comply with the sign area limitations applicable to the site.
- Murals that illustrate the local setting, history, or cultural significance as sources of inspiration are encouraged.
- The approval of a mural shall require that the review authority first find that the colors, placement, and size of the mural are visually compatible with the structure's architecture, and that the mural will serve to enhance the aesthetics of the City.

**E. Mounting Details:**

- Mounting details may be placed on the Sign Plan or as a separate sheet but must include the following:
- Description of material used in construction of sign.
- Thickness and approximate weight of sign for suspended or projecting signs.
- Means of exterior or interior lighting including shielding, type, and size of lamps (if applicable).
- For suspended signs provide details of anti-sway devices.

PINECREEK SHOPPING CENTER  
GRASS VALLEY, CALIFORNIA  
EXHIBIT E  
SIGN CRITERIA  
~~FEBRUARY 17, 1988~~ January 14, 2025

These criteria have been established for the purpose of maintaining a continuity of quality and aesthetics throughout the shopping center for the mutual benefit of all tenants and to comply with the regulations of the City of Grass Valley. Conformance will be strictly enforced and any installed nonconforming or unapproved signs must be brought into conformance at the expense of the tenant.

I. GENERAL REQUIREMENTS - ALL SIGNS

- A. Each Tenant shall submit or cause to be submitted to the Landlord for approval, prior to fabrication, ~~four~~one (4) ~~copies~~ .PDF e-copy of detailed drawings indicating the location, size, layout, design, dimensions, colors, illumination, materials and method of attachment of all signage.
- B. All Permits for signs and their installation shall be obtained and paid to the City of Grass Valley by the Tenant or his representative prior to fabrication and installation.
- C. All signs shall be constructed and installed at the Tenant's expense.
- D. Tenant shall be responsible for the fulfillment of all requirements and specifications, including those of the City of Grass Valley.
- E. All signs shall be reviewed for conformance with these criteria and overall design quality. Approval or disapproval of sign submittals based on aesthetics of design shall remain the right of the Landlord or his authorized representative and the City of Grass Valley.
- F. Tenant shall be responsible for the installation and maintenance of his sign. Should Tenant's sign require maintenance or repair, Landlord shall give Tenant thirty (30) days written notice to perform said maintenance or repair. Should Tenant fail to do same; Landlord shall undertake repairs and Tenant shall reimburse Landlord within ten (10) days from receipt of invoice.

II. -----  
SPECIFICATIONS - ALL SIGNS

All companies bidding to manufacture these signs are advised that no substitutes will be accepted by Tenant whatsoever, unless so indicated in the specifications and approved by Landlord and Tenant. Any deviation from these specifications may result in purchaser's refusal to accept same.

All manufacturers are advised that prior to acceptance and final payment, each unit will be inspected for conformance by an authorized representative of Landlord. Any signs found not in conformance will be rejected and removed at Tenant's expense.

Tenant is required to have signs as shown on attached Exhibits E installed and operable upon lease commencement date.

A. General Specifications

- 1. No animated, flashing or audible signs will be permitted.
- 2. No exposed lamps or tubing will be permitted.

0. All signs and their installation shall comply with all local building codes, electrical codes and the City of Grass Valley Sign Ordinance.
1. No portable signs will be permitted.
2. Grand opening or promotional signs shall comply with the City of Grass Valley Sign Ordinance and be approved by Landlord prior to installation.
3. No exposed raceways, crossovers or conduit will be permitted.
4. All cabinets, conductors, transformers and other equipment shall be concealed.
5. Painted lettering will not be permitted.

B. Location of Signs

1. All signs or devices advertising an individual use, business or building shall be attached to the building at the location directed by Landlord and in accordance with this sign criteria.

III. DESIGN REQUIREMENTS

A. Canopy Signs (In-line Shops)

Pertains to: Buildings 1, 3 (Spaces 1 and 2), 5, 6  
(Spaces 2 and 3), 8 and Pad B

1. Individual Letter Sign
  - a. All Tenant signs shall be of individual letter construction, mounted structurally, electrically and individually on the raceway as shown on Exhibit E-1 attached hereto. Sign cabinets will not be permitted.
  - b. Each letter or numeral will be internally illuminated and will be faced with plexiglass or similar material.
  - c. Maximum width shall be equal to eighty (80%) percent of the lineal leased frontage except as noted in criteria A.1.d. In any case, no sign shall be greater than fifty (50) lineal feet wide.
  - d. Maximum sign width for Building 3, Space 1 shall not exceed twenty (20) feet. Further, the maximum width of signage for Building 6, Spaces 2 and 3 and Building 8, Space I shall not exceed twelve (12) feet for each named space.
  - e. Letter height shall be twenty-four (24") inches except for Building 3, Space 1 where letter height shall be thirty-six (36") inches. If Tenant's name cannot be accommodated in that size, smaller letters may be approved. ~~Minimum acceptable letter size shall be eighteen (18") inches.~~
  - f. Logos shall not exceed ten (10%) percent of sign area and will be included in the allowable signage subject to criteria A.1.c. and A.1.d. The maximum height of logos shall be twenty-four (24") inches except for Building 3, Space 1 where logos shall not exceed thirty-six (36") inches. National brand logos greater than 10% of sign area may be considered on a case-by-case basis.

- g. Sign copy shall include minimal information only. The name of the store shall be depicted on the sign.
- h. Letter faces shall be 3/16" acrylic with 3/4" trimcap retainers used at the perimeter. ~~Trimcap color shall be gold.~~ Returns of individual letters shall be five (5") inches. Colors shall be considered on a case by case basis and may not duplicate the sign color used by adjacent stores except at Landlord's discretion. Exterior color shall be Dupont Duranodic #313 Dark Bronze.
- i. ~~Neon tubing shall be fifteen (15mm) millimeters.~~

B. Undercanopy Signs

- 1. Tenant shall install a non-illuminated undercanopy sign in accordance with Exhibit E-1 attached hereto. Said sign shall be located as depicted on that exhibit.
- 2. One (1) undercanopy sign shall be allowed per Tenant.

C. Arcade Signs

Pertains to: Buildings 2, 3 (Space 3), 4, 6 (Space 1), 7 and Future Major Tenants

- 1. Individual Letter Sign
  - a. All Tenant signs shall be of individual letter construction, mounted structurally, electrically and individually on the raceway as shown on Exhibit E-2 attached hereto. Sign cabinets will not be permitted.
  - b. Each letter or numeral will be internally illuminated and will be faced with plexiglass or similar material.
  - c. Sign width shall not exceed the following:
    - Building 2 Thirty (30) feet
    - Building 3 Twenty-six (26) feet
    - Space 3
    - Building 4 Twenty-eight & one-half (28.5) feet
    - Building 6 Twenty (20) feet
    - Space 1
    - Building 7 Forty-one (41) feet
  - d. Letter height shall not exceed the following:
    - Building 2 Forty-eight (48) inches
    - Building 3, Space 3 Twenty-four (24) inches
    - Building 4 Sixty (60) inches
    - Building 6, Space 1 Thirty-six (36) inches
    - Building 7 Twenty-eight (28) inches
  - e. Logos shall not exceed ten (10%) percent of sign area and will be included in the allowable signage subject to criteria C.1.c. and C.1.d. The maximum height of logos shall not exceed that of sign letters as specified in C.1.d. National brand logos of greater than 10% of sign area or greater height than sign letters may be considered on a case-by-case basis.

- f. Sign copy shall include minimal information only. The name of the store shall be depicted on the sign.
- g. Letter faces shall be 3/16" acrylic with 3/4" trimcap retainers used at the perimeter. ~~Trimcap color shall be gold.~~ Returns of individual letters shall be five (5") inches. Colors shall be considered on a case by case basis and may not duplicate the sign color used by adjacent stores except at Landlord's discretion. Exterior color shall be Dupont Duranodic \*313 Dark Bronze.
- i. ~~Neon tubing shall be fifteen (15mm) millimeters.~~  
Signing for major tenants (~~5,000 square feet minimum~~ with five or more locations) will be considered on an individual basis subject to Landlord's criteria and City of Grass Valley ordinances.

D. Pad Signs \_ \_ Wall

Pertains to: All Pads except Pad B

1. Individual Letter Sign

- a. All Tenant signs shall be of individual letter construction, mounted structurally, electrically and individually on the raceway as shown on Exhibit E-3 attached hereto. Sign cabinets will not be permitted.
- b. Each letter or numeral will be internally illuminated and will be faced with plexiglass or similar material.
- c. Sign size will be proportionate to the building or development involved. The aggregate area of all signs on the building shall not exceed two (2) square feet for each lineal foot of frontage. ~~Frontage shall be determined at the entry and that portion of the establishment that abuts on the street. Tenants will be permitted one (1) sign for each exterior wall of their demised premises which faces the public.~~
- d. Letter height shall not exceed forty-eight (48") inches. If Tenant's name cannot be accommodated in that size, smaller letters may be approved. ~~Minimum acceptable letter size shall be eighteen (18") inches.~~
- e. Logos shall not exceed ten (10%) percent of sign area and will be included in the allowable signage subject to criteria D.l.c. and D.l.d. The maximum height of logos shall be forty-eight (48") inches. National brand logos greater than 10% of sign area may be considered on a case-by-case basis.

- f. Sign copy shall include minimal information only. The name of the store shall be depicted on the sign.

- g. Letter faces shall be 3/16" acrylic with 62,..4<sup>3</sup>' trimcap retainers used at the perimeter. ~~Trimcap color shall be gold.~~ Returns of individual letters shall be five (5") inches. Colors shall be considered on a case by case basis and may not duplicate the sign color used by adjacent stores except at Landlord's discretion. Exterior color shall be Dupont Duranodic #313 Dark Bronze.

- h. ~~Neon tubing shall be fifteen (15mm) millimeters.~~

E. Pad Signs - Monument

Pertains to: All Pads except Pad B

1. Number is limited to one (1) per pad building.
2. Size may not exceed thirty-six (36) square feet for a single face. Height shall be six (6) feet including the sign base which shall be two (2) feet in height.
3. Construction shall be as shown on Exhibit E-4.
4. Minor variations to the specifications contained herein will be considered on a case-by-case basis by the Landlord when it is determined such consideration is in the best interests of the shopping center.

IV. CONSTRUCTION REQUIREMENTS

- A. All exterior signs shall be installed per Exhibits E attached. Signs shall bear the UL label and comply with all required codes. Exterior signs shall be secured by concealed fasteners, stainless steel or nickel or cadmium plated.
- B. Sign outlet will be provided by Landlord. Fluorescent lights, tubes and timeclocks shall be provided and installed by Tenant.
- C. All exterior signs exposed to the weather shall be mounted at least 3/4" from the building to permit proper direct and water drainage.
- D. All penetrations of the building structure required for sign installation shall be neatly sealed and watertight.
- E. No labels will be permitted on the exposed surface of signs except those required by local ordinance and those shall be placed in an inconspicuous location.
- F. Sign contractor shall repair any damage to any work caused by hie work. Damage to structure that is not repaired by the sign contractor shall become the Tenant's responsibility to correct.
- G. Tenant shall be fully responsible for the operations of its sign contractor.

V. GUARANTEE

- A. Entire display shall be guaranteed for one (1) year from ~~date~~ date of installation against defects in materials and workmanship. Defective parts shall be replaced without charge.

VI. INSURANCE

- A. Sign contractor shall carry workers' compensation and public liability insurance against all damage suffered or done to any and all persons and/or property while engaged in the construction or erection of signs in the amount of ~~five hundred thousand~~ two million dollars (~~\$2,050,000~~) combined single limit.

VII. INSTALLATION

- A. Landlord reserves the right to hire an independent electrical engineer (at Tenant's sole expense) to inspect the installation of all tenant signs and to require the Tenant to have any discrepancies and/or code violations corrected at the Tenant's expense.

VIII. HOURS OF OPERATION

- A. Sign lighting will be operated by time clocks to be provided by Tenant. Hours of illumination shall be mandated by Tenant's Lease.

IX. MISCELLANEOUS REQUIREMENTS

- A. Each tenant shall be permitted to place upon each entrance of its demised premises not more than one hundred forty four (144) square inches of vinyl, ~~Seotheal #365A gold~~ lettering not to exceed two (2") inches in height, indicating hours of business, emergency telephone numbers, etc.
- B. Except as provided herein, no advertising placards, banners, pennants, names, insignia, trademarks, or other descriptive material shall be affixed or maintained upon either the interior or exterior of the glass planes and supports of the show windows and doors, or upon the exterior walls of the buildings.
- C. If Tenant has a non-customer door for receiving merchandise, Tenant may have its name and address uniformly applied to said door in such location directed by the Project Manager. Application shall consist of black block letters which are ~~two-four~~ (24) inches high. If more than one Tenant uses the same noncustomer door, each Tenant's name and address shall be applied to said door.
- D. At the expiration or sooner termination of Tenant's lease term, Tenant shall be required to remove his signs and patch the canopy and fascia and paint the patched area to match the surrounding areas.

X. COLORS

- A. ~~The following Plexiglas Brand colors are approved for use in all Tenant signs. Additional colors are subject to Landlord's approval.~~

<del>White</del>	<del>#7328</del>	<del>Yellow</del>	<del>#2325</del>
<del>Ivory</del>	<del>#2146</del>	<del>Red</del>	<del>#2793</del>
<del>Yellow</del>	<del>#2037</del>	<del>Green</del>	<del>#2108</del>
<del>Orange</del>	<del>#2119</del>	<del>Black</del>	<del>#2025</del>
<del>Blue</del>	<del>#2114</del>	<del>Brown</del>	<del>#2418</del>



/ciz\_cri, c\_

The following Plexiglas Brand color. are approved for us in all Tenant signs. Additional colors are subject to Landlord approval.

White 17328	<b>015</b>	Yellow 12325	42-4- 218 507 q9 -3Z4
Ivory 02146	<b>047</b>	Red 02793	
Yellow 12037	<b>4.00</b>	Green 02108	
Orange 12119	<b>73</b>	Black 02025	
Blue 12114	<b>GO5</b>	Brown 02418	

2793 RED & 2114 BLUE  
Do NOT ILLUMINATE WELL

REMOVAL OF SIGN

- A. If the fascia sign is removed for replacement or because of termination of Lease, Tenant shall leave the reader board or fascia in good condition, normal wear and tear excepted. Without limitation, Tenant shall be specifically required to fill in, in a professional manner, any holes in the fascia panel caused by removal of the sign and conduit, and, if necessary, shall pay for any painting and/or waterproofing that is necessary to repair said work and to remove sign or "shadows".

0.45' 0"W  
0" 1'

EXHIBIT PAGES 1 - 8 UNCHANGED

DOCUMENT DATE 11/14/14  
SY/EE  
11/14/14

COST SAVINGS

PINF OFFER SHOPPING CENTER  
PADS A, B & C

BRASSY WARE WAREHOUSE

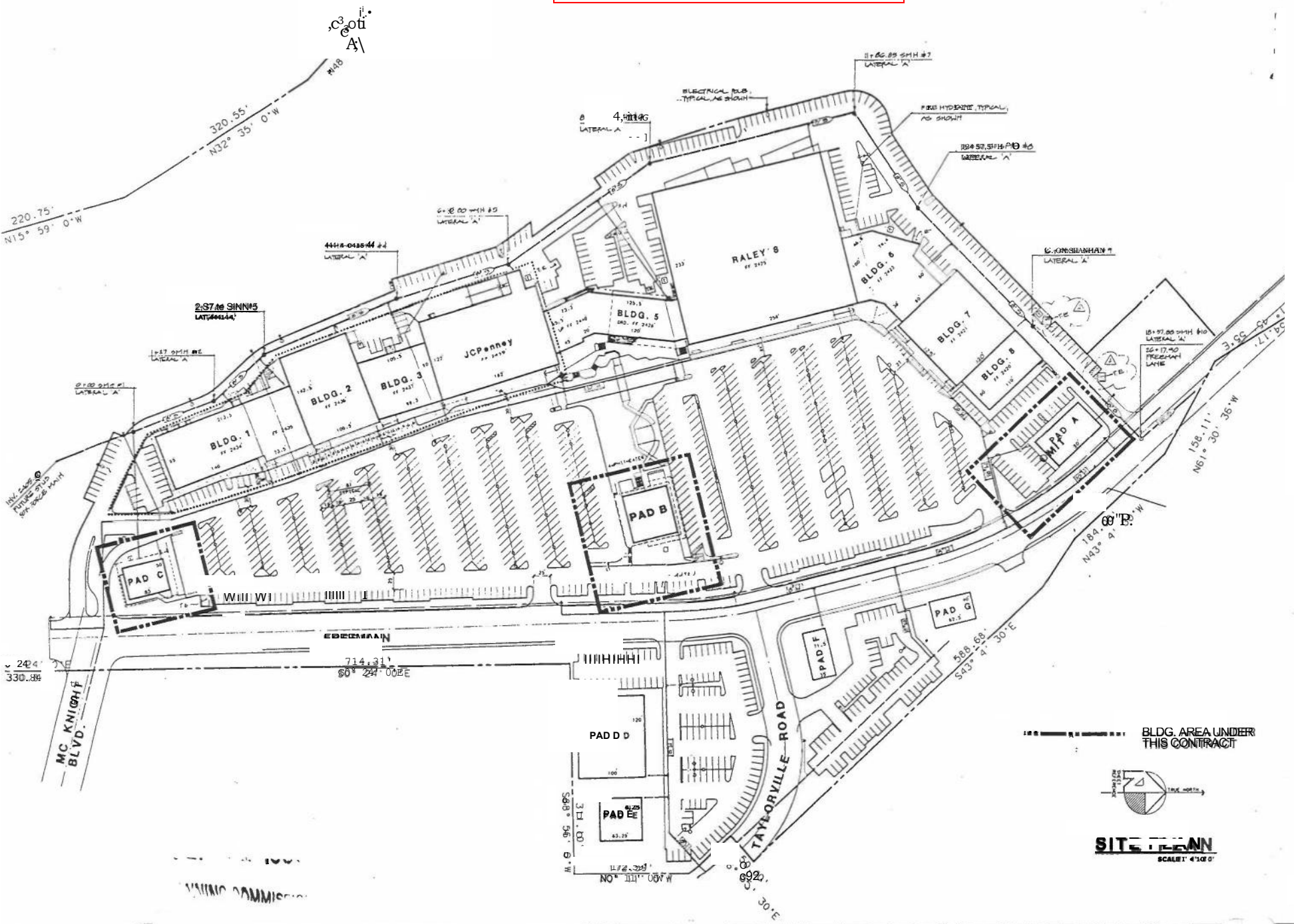

BLDG. AREA UNDER THIS CONTRACT



SITE PLAN  
SCALE: 1" = 40' 0"

DESIGNED BY: GARDNER WHITFIELD ARCHITECTS  
 ARCHITECT: GARDNER WHITFIELD ARCHITECTS  
 1771 STOCKTON BLVD., SUITE 100  
 RICHMOND, VA 23220  
 (804) 771-1111

**HAVLICK & HUGHES**  
 ENGINEERS, ARCHITECTS & PLANNERS

DATE: 2-23-14  
 DRAWN: DS  
 JOB: 8438

**A11**  
 11/14/14

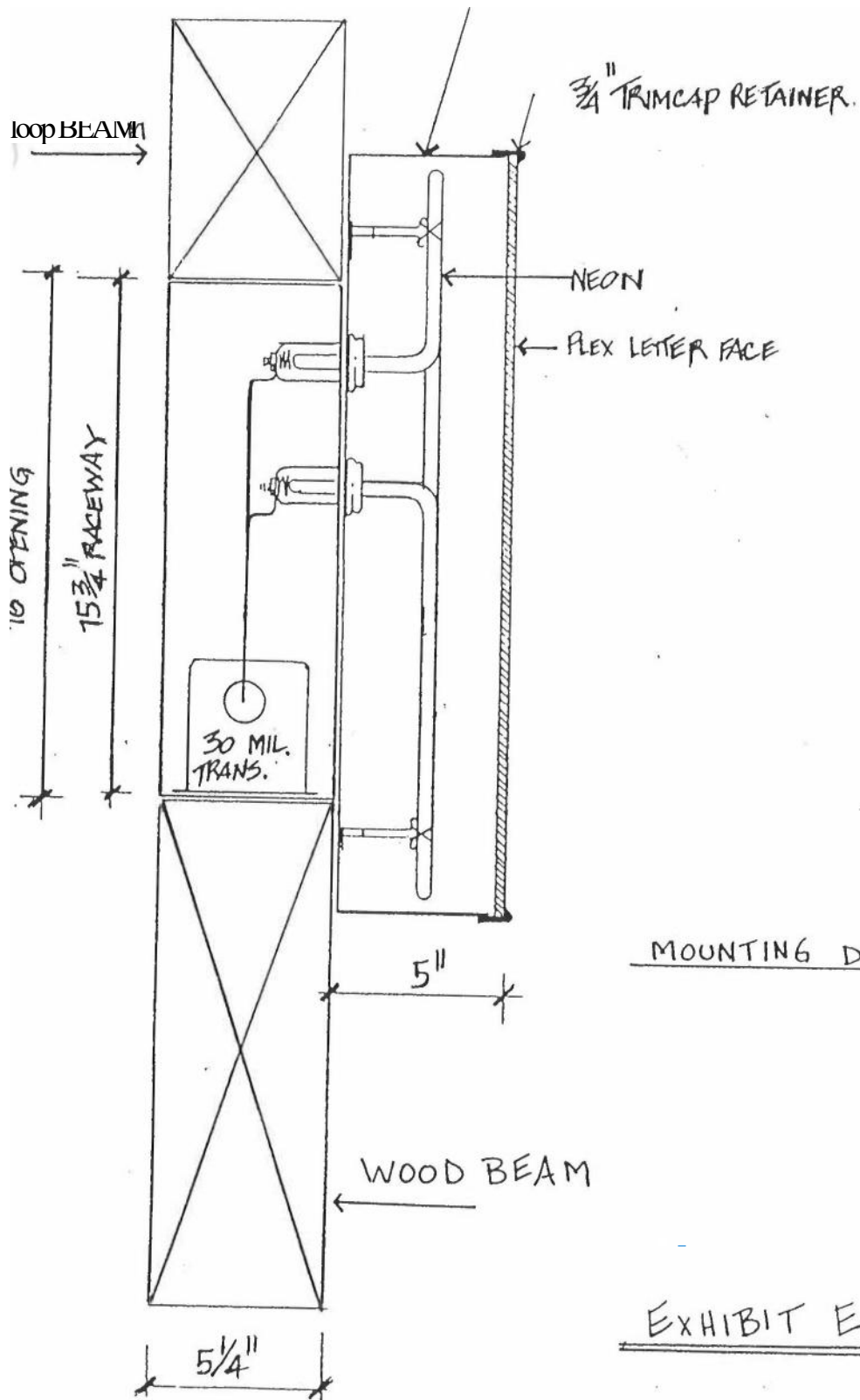

MOUNTING DETAIL

EXHIBIT E-1

1

**TENANT**

t OFF 4JJ'  
✓ Eq: 7'

**SIGN "A"**

**SIGNB AND SIGN**

**ELEVATION**

**1/4":1'-0"**

(See Section III - A1, C, D, and E of Sign Criteria for exact permitted dimensions.)

Gi. 'S VALLEY, CALIFORNIA

January 14, 1988

**RAISED LETTERS**

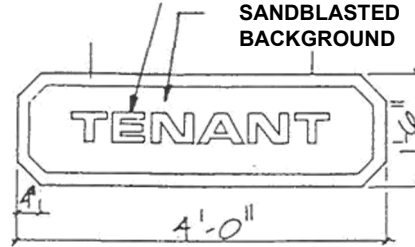

SANDBLASTED REDWOOD TYPE SIGN SUSPENDED BY CHAINS, BACKGROUND AND BORDER STAINED TO MATCH BLDG, TENANT MAY SELECT LETTER STYLE AND COLOR,

**SIGN "B"**

**UNDER CANOPY SIGN**

**1/2":1'-0"**

**IN-LINE SHOPS SIGN CRITERIA**

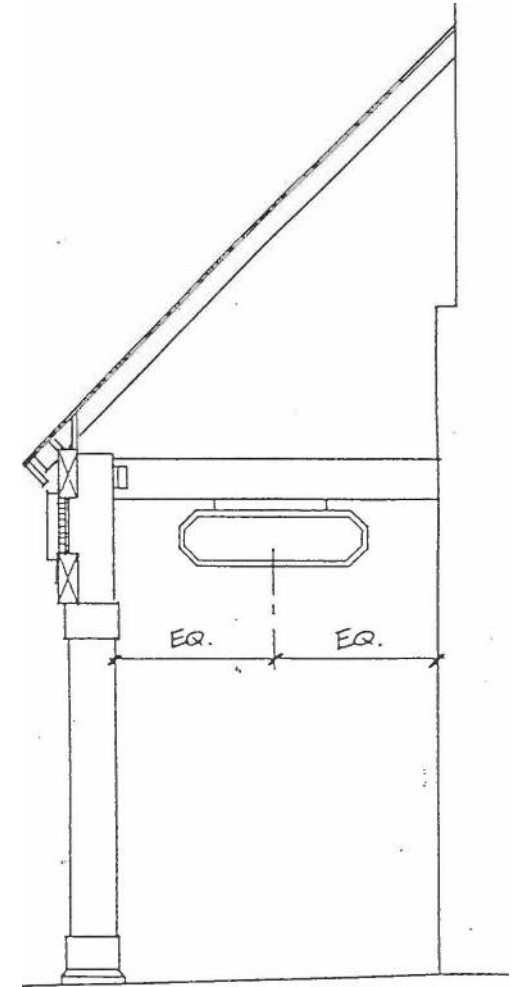

**SECTION 1/4":1'-0"**

**EXHIBIT E 1**

Note: "BRNO'S" is used as a graphic presentation only. It does not necessarily imply that BENO'S will be a tenant in this center.

(See Section

C.1, C and D of Sign Criteria for exact permitted dimensions.)

---

BENO'S ~~Sam~~

---

CH

---

**PINE CREEK' CENTER**

January 14, 1988.

**EXHIBIT E-2**

**MAJOR TENANT SIGNS**

BUILDINGS 2, 3 (Space 3), 4, BUILDING .6 (Space 1) and 7

**ARCADE SIGN CRITERIA**

**EXHIBIT E-2**

# MONUMENT SIGN CRITERIA - PAD BUILDINGS

WILSON CREEK CENTER

GRASS VALLEY, CALIFORNIA

NOV. 2, 1987

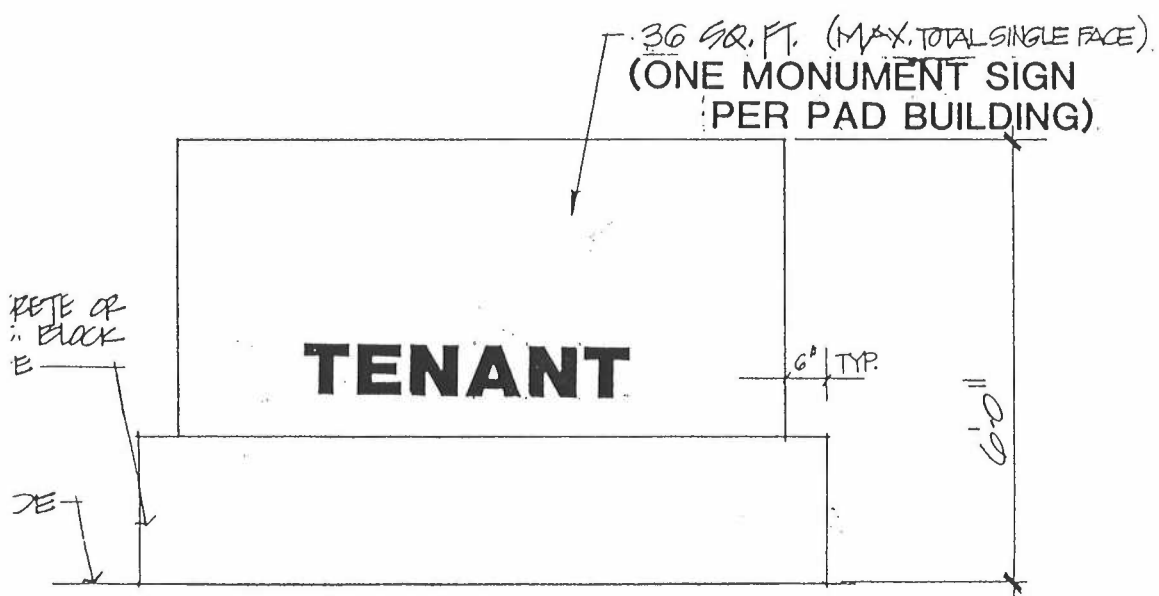

SIGN SUBJECT TO ARCHITECTURAL REVIEW AND APPROVAL BY OWNER



# PAD t DG. I ENANT SIGN CRITERIA

**PINE' CREEK CENTER**

January 14, 1988

**EXHIBIT E -3**

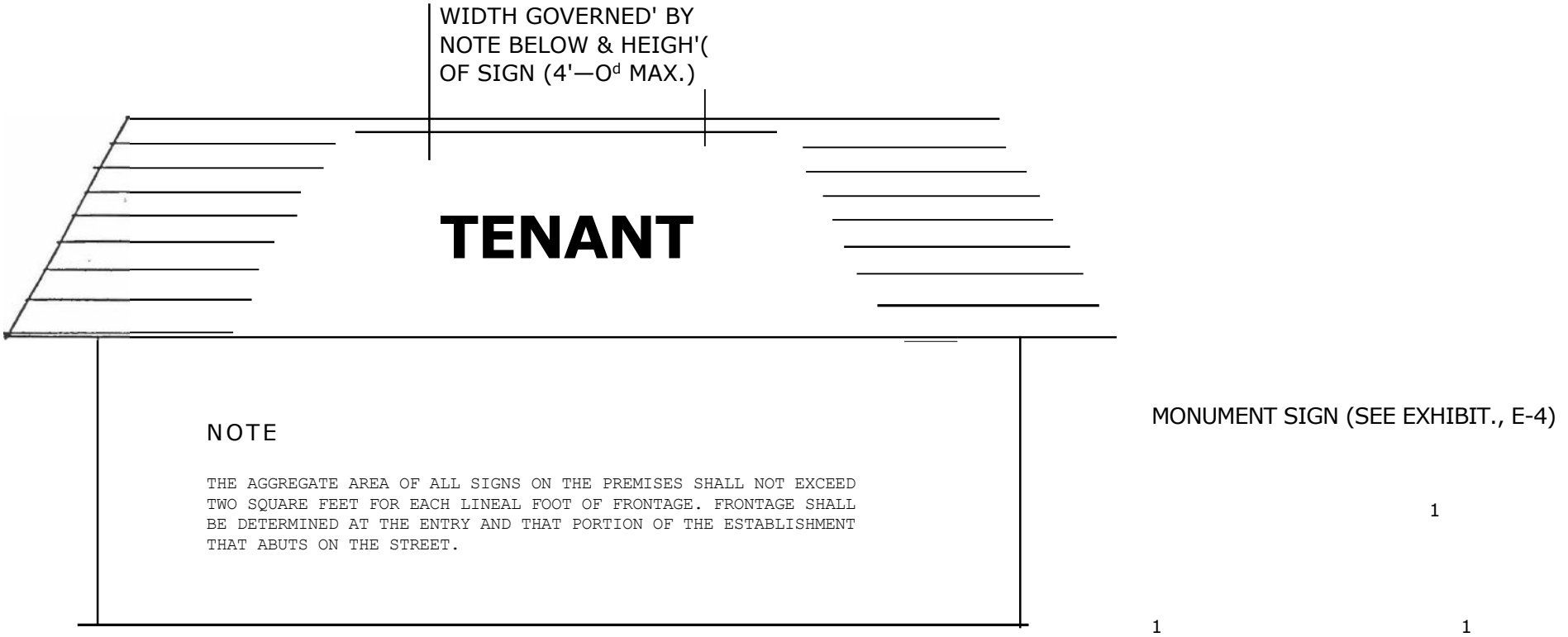

**SIGNS SUBJECT TO ARCHITECTURAL  
REVIEW AND APPROVAL BY OWNER**

## EXHIBIT E-3

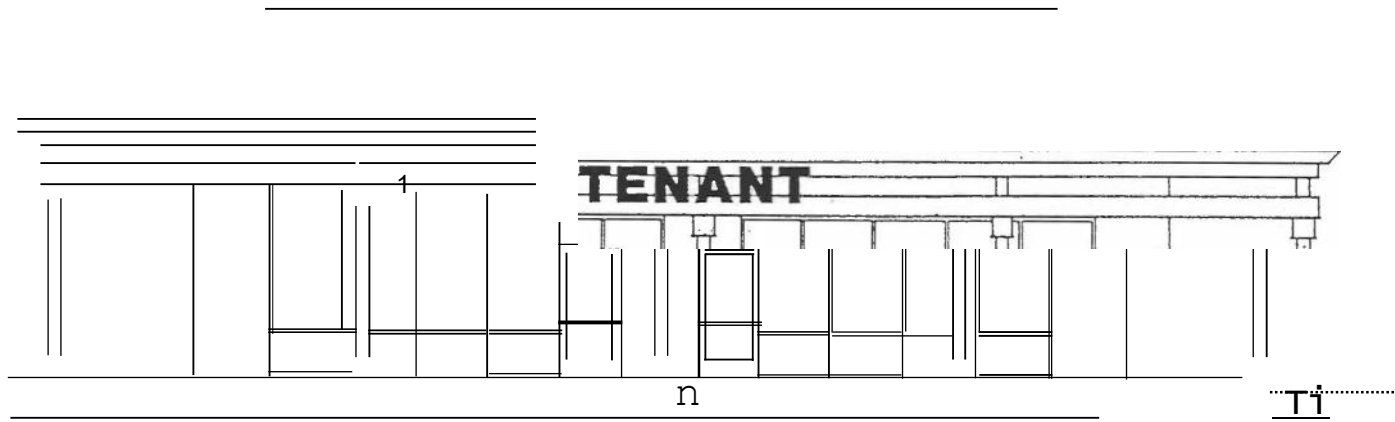

**PAD A WALL SIGN**  
**SEE EXHIBIT E-3**

FOR PAD MONUMENT  
SEE EXHIBIT E-4

ALL SIGNS SUBJECT TO ARCHITECTURAL  
REVIEW AND APPROVAL BY THE OWNER

• -----