

ARIA INSTALLATION GUIDE

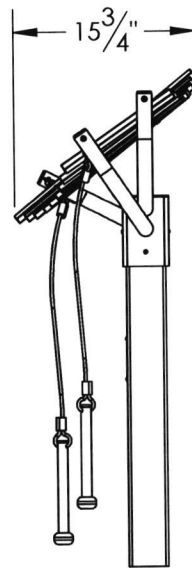
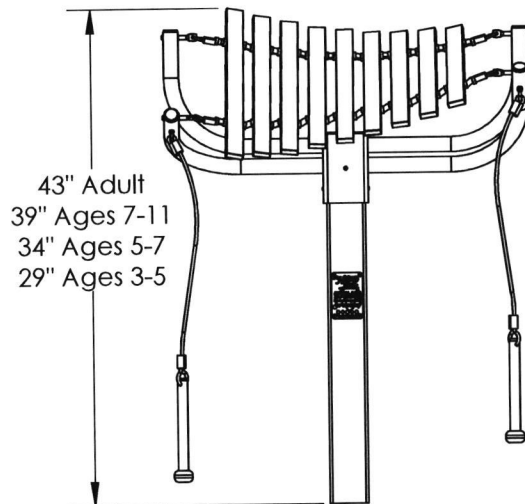
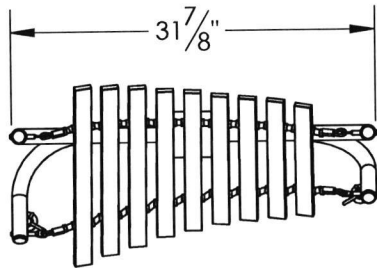
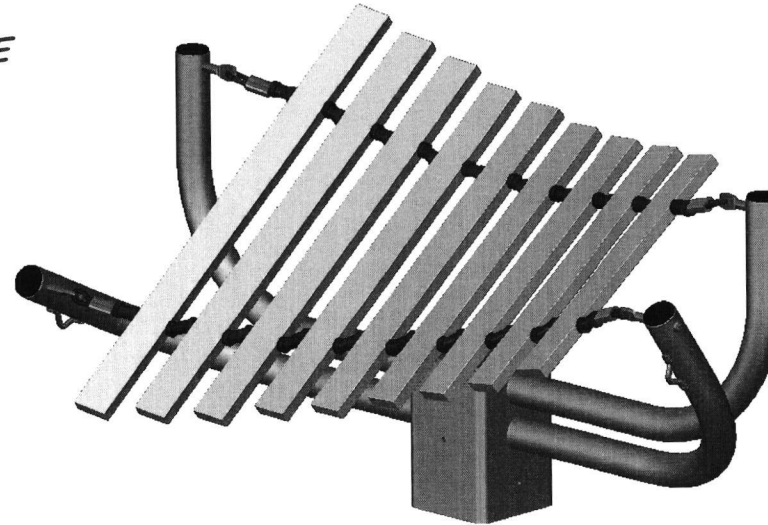

Main Features:

- C Major Pentatonic
- Steel Powder Coated Frame
- Anodized Aluminum Bars
- Stainless Steel Hardware

Contents:

- SHEET 2 - Parts List and Instrument to Post Installation
- SHEET 3 - In Ground Installation
- SHEET 4 - Surface Mount Installation

Weights:

- Instrument Weight, 35lbs.
- Boxed Instrument Weight, 44lbs.
- Boxed Post Weight, 28-36lbs.

Parts List:

ITEM NO.	PART NUMBER	DESCRIPTION	In Ground Recycled QTY.	In Ground Steel QTY.	Surface Mount Recycled QTY.	Surface Mount Steel QTY.
1	ARIA-BOM-REC	Pre-Assembly - Aria Instrument (For Recycled Post)	1	-	1	-
2	ARIA-BOM-STL-IG	Pre-Assembly - Aria Instrument (For Steel In Ground)	-	1	-	-
3	ARIA-BOM-STL-SM	Pre-Assembly - Aria Instrument (For Steel Surface Mount)	-	-	-	1
4	POST-REC-68-DEG0-SIGN	In Ground Recycled Post, 68"lg. w/ Name Plate	1	-	-	-
5	POST-REC-32-DEG0-SIGN	Surface Mount Recycled Post, 32"lg. w/ Name Plate	-	-	1	-
6	SM-BASE-REC	Surface Mount Base HDPE, For Recycled Post (1.5" Black)	-	-	1	-
7	10N200TBTS	#10 Button Head Screw, 2"lg. SS, T25 tamp	4	-	4	-
8	POW 07315	3/8"-16 Wedge Expansion Anchor, 3.75"lg. SS	-	-	-	4
9	POW 07316	3/8"-16 Wedge Expansion Anchor, 5"lg. SS	-	-	4	-
10	9267K43	35/64" Hex Nut Cap	-	-	4	4
11	31N500BHLS	5/16" Hex Head Lag Bolt, 5"lg. SS	-	-	2	-
12	12192	T25 x 1" Driver (Tamper Resistant)	1	-	1	-

Step 1: The Steel Post Options do not require assembling the Instrument to the Post, as the Post and Instrument are one unit. If mounting to a Recycled Post, follow the instructions below.

Step 2: With two people, situate the Instrument onto the Post. Predrill 5/32" pilot holes into the Posts through the existing holes on the Instrument Frame. Fasten the Instrument to the Post with the provided #10 Button Head Screws and Security Driver.

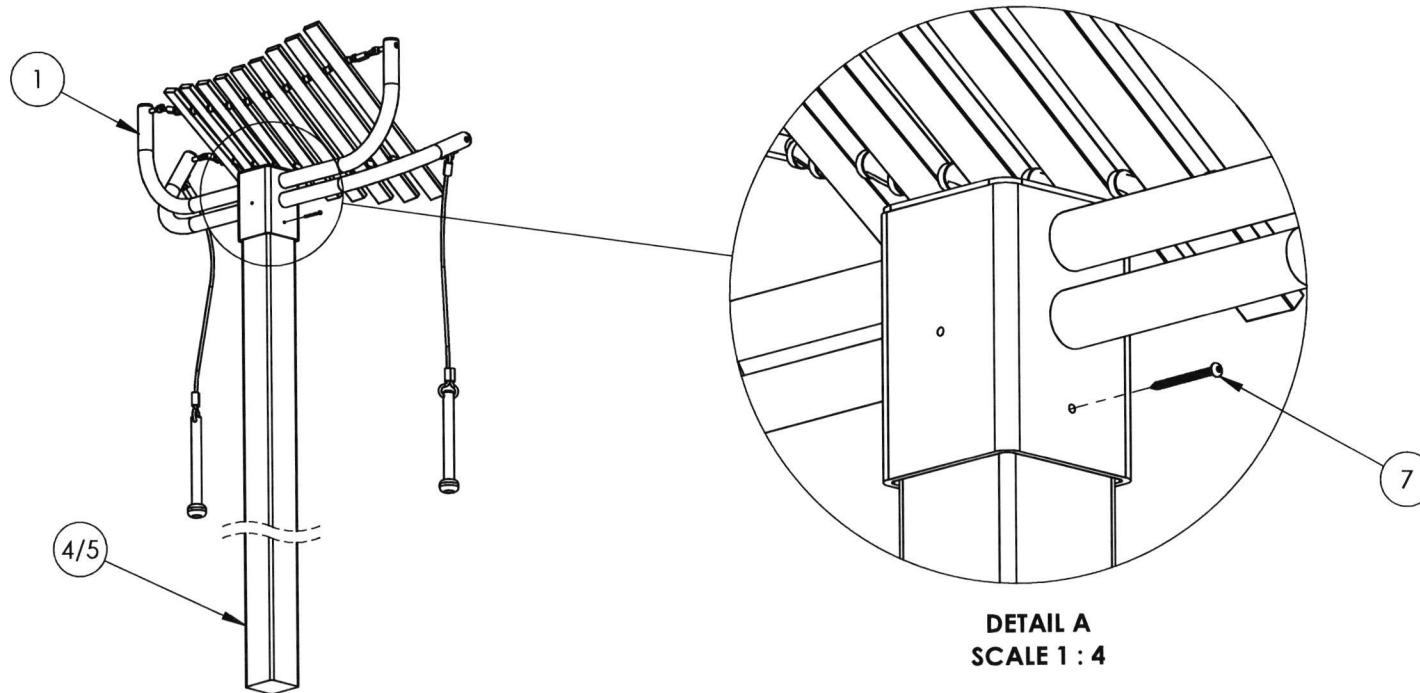

Step 1: Excavate one 10" diameter hole, 36" deep, at the installation location. Contractor can modify Post to desired height.

Post Length = Frost Depth (36" Recommended) + Finished Post Height

Finished Post Height Guideline: (Ages 3-5, 20") (Ages 5-7, 25") (Ages 7-11, 30") (Adult, 34")

Step 2: With two people, lower the Post with the Instrument attached into the excavated hole.

Step 3: Verify the correct placement, levelness, and finished height of the Instrument. Check for sufficient clearance around the Instrument, a 36" perimeter around the Instrument is recommended for wheelchair accessibility.

Step 4: Last pour concrete around the post. It is recommended to brace the Instrument to hold it rigid while the concrete cures. Leave to set according to the concrete manufacturers guidelines. Approximately (3) 80lb. bags will be needed.

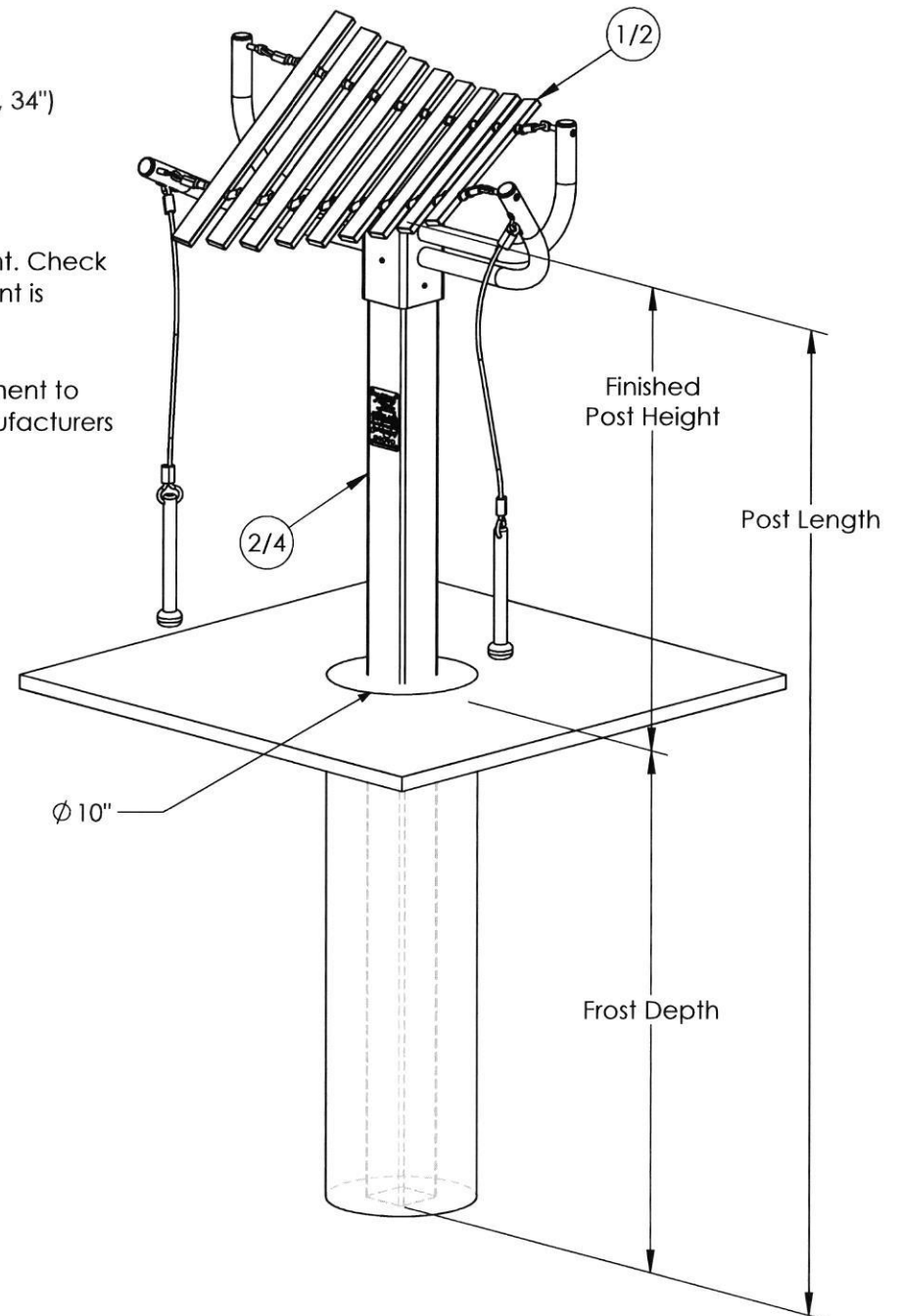

Step 1: Standard height for Surface Mount Posts are 36". The Recycled Post may be modified in the field to the following heights:

(Ages 3-5, 20") (Ages 5-7, 25") (Ages 7-11, 30") (Adult, 34")

The height of Surface Mount Steel Posts can not be adjusted.

Step 2: Determine installation location. Verify concrete footing is a minimum of 24" long x 24" wide x 6" thick. If the concrete pad is at an angle, steel washers are required to act as shims (Shims not provided). If there is not already an existing pad, approximately (4) 80lb. bags will be needed. Allow concrete to cure per concrete manufacturers guidelines.

Step 3 (Recycled Post Only): Install the Surface Mount Base to the bottom of the Post. Align the holes on the Base with the holes on the Post. The Base should fit snugly around the Post. Fasten them together with the provided 5/16" Hex Head Lag Bolts.

Step 4: With two people place the Instrument Assembly with Post attached onto the concrete pad and mark the center of the holes on the surface mount base. After you have made your marks, set aside the Instrument in order to drill for anchor holes. With a hammer or rotary drill, drill through concrete at marked locations. Drill to a minimum depth of 4". A 3/8" masonry drill bit will be needed.

Step 5: Place the Instrument back over the drilled out holes. Insert provided anchor bolts into aligned holes. Position anchor nut so that it is flush with the top of the bolt. Pound anchor bolts into the hole until the anchor washer is flush with the surface mount base. Tighten anchor bolts until they are snug. Cover remaining bolt sections with provided nut caps.

Step 6: Verify the correct placement, levelness, and finished height of the Instrument. Check for sufficient clearance around the Instrument, a 36" perimeter around the Instrument is recommended for wheelchair accessibility.

Step 7: If installing onto wet concrete, us the wet set anchor manufacturers guidelines for installation procedures.

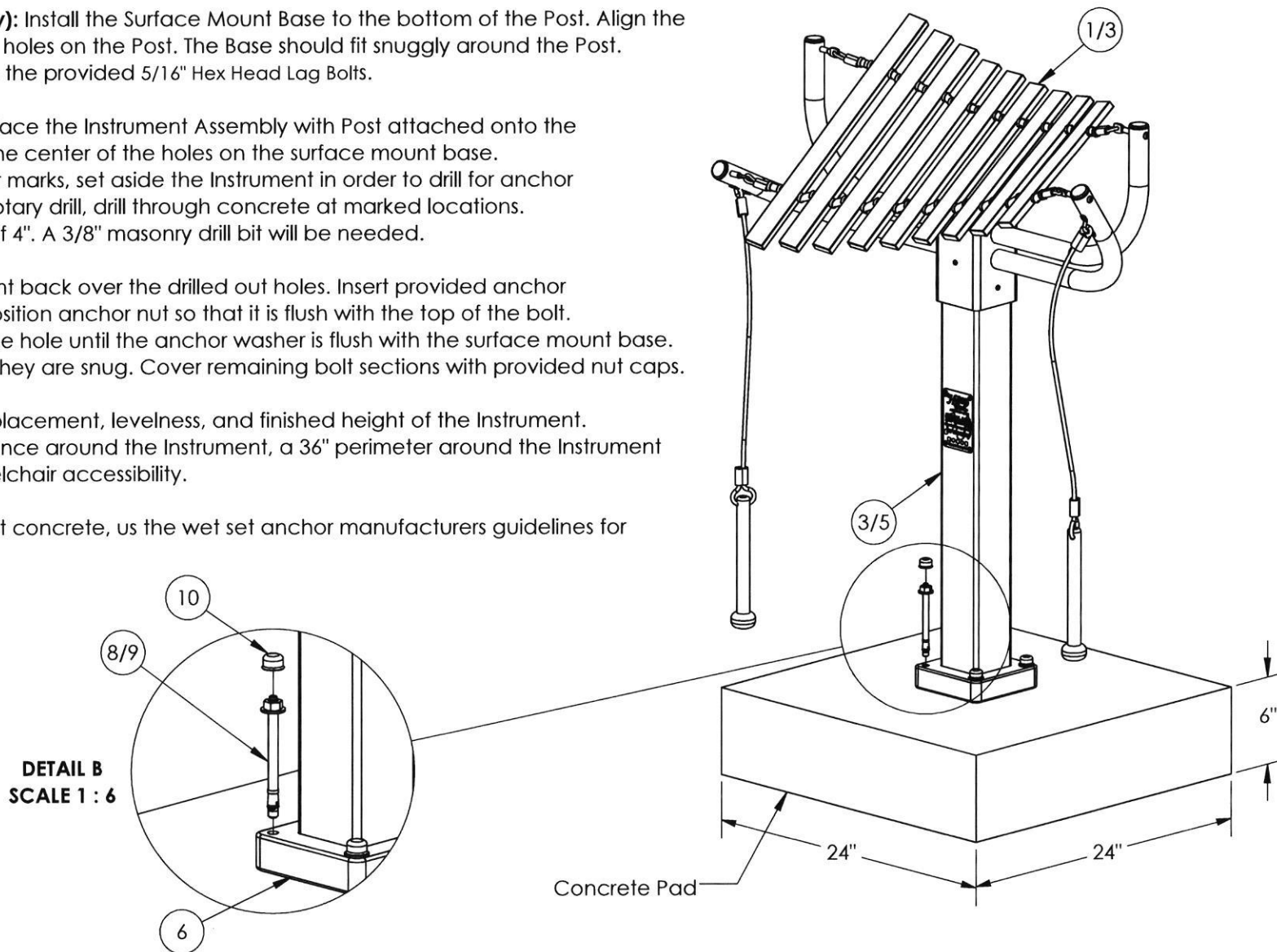

CONTRABASS CHIMES INSTALLATION GUIDE



FREENOTES HARMONY PARK
544 CHESTNUT ST.
CHATTANOOGA, TN 37402
TEL: 833.262.1569

WWW.FREENOTESHARMONYPARK.COM

PROPRIETARY AND CONFIDENTIAL
THE INFORMATION CONTAINED IN THIS
DRAWING IS THE SOLE PROPERTY OF
FREENOTES HARMONY PARK. ANY
REPRODUCTION IN PART OR AS A
WHOLE WITHOUT THE WRITTEN
PERMISSION OF FREENOTES HARMONY
PARK IS PROHIBITED.

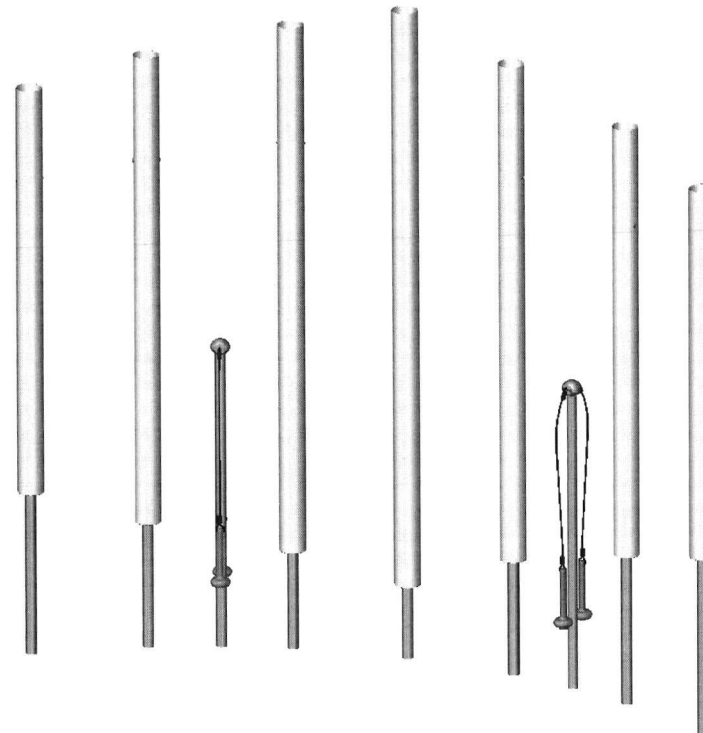
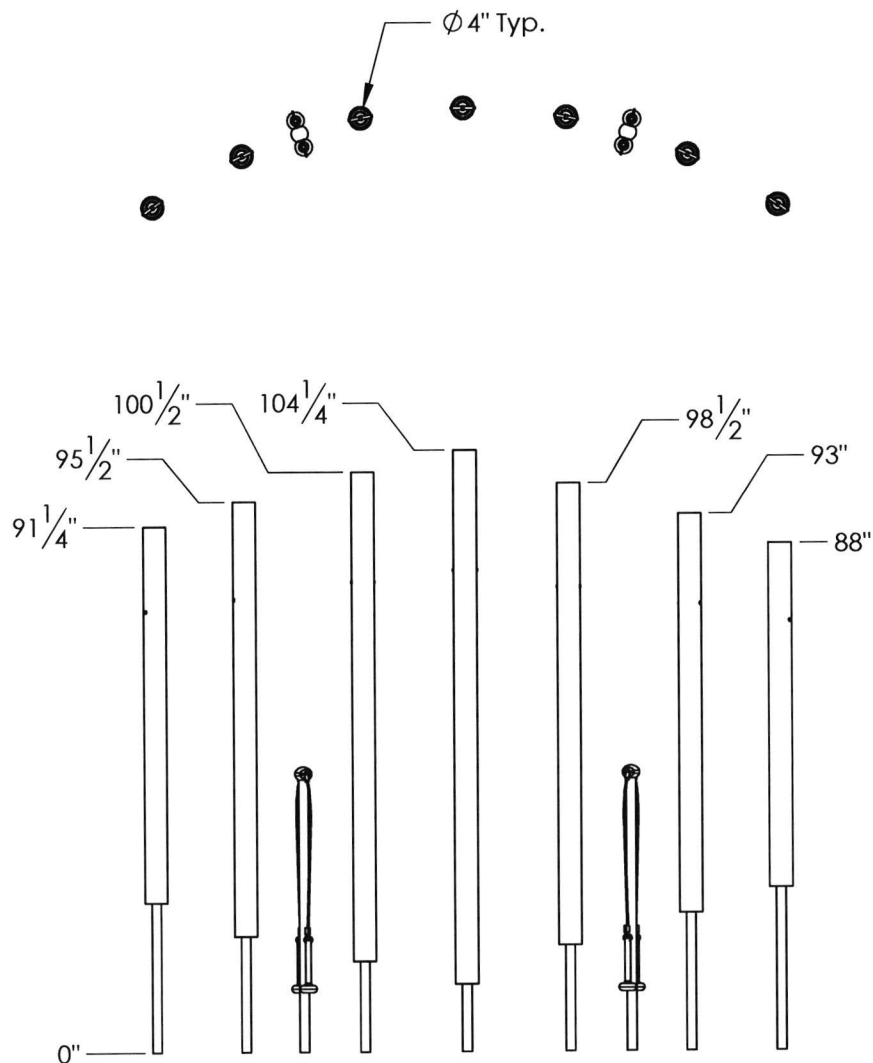

Main Features:

- C Major Pentatonic
- Steel Powder Coated Support Poles
- Anodized Aluminum Chimes
- Stainless Steel Hardware

Contents:

- SHEET 2 - In Ground Installation w/ Parts List
- SHEET 3 - Surface Mount Installation w/ Parts List

Weights:

- Instrument Weight, 30-35lbs per chime
- Boxed Instrument Weight, 35-40lbs. per chime
- Mallet Pole Weight, 37lbs.
- Boxed Mallet Pole Weight, 40lbs.

TITLE:

Contrabass Chimes - Installation Guide

DWG. NO. CCH-INSTALL

REVISION: B

SCALE: 1:32

DATE: 1/30/2019

SHEET 1 OF 3

Parts List:

ITEM NO.	DESCRIPTION	QTY.
1	Contrabass Chimes - In Ground Chime Assembly 1	1
2	Contrabass Chimes - In Ground Chime Assembly 2	1
3	Contrabass Chimes - In Ground Chime Assembly 3	1
4	Contrabass Chimes - In Ground Chime Assembly 4	1
5	Contrabass Chimes - In Ground Chime Assembly 5	1
6	Contrabass Chimes - In Ground Chime Assembly 6	1
7	Contrabass Chimes - In Ground Chime Assembly 7	1
8	Contrabass Chimes - In Ground Mallet Pole Assembly	2

Step 1: Determine your layout. Spacing between Chimes and Mallet Poles must be maintained per the diagram shown to allow the Mallets to reach each Chime. Although the Chimes can be laid out in a variety of styles such as an arc, wave, or straight-line; we suggest one of the following layout orders:

- #6, #4, Mallet Pole, #2, #1, #3, Mallet Pole, #5, #7
or
 #1, #2, Mallet Pole, #3, #4, #5, Mallet Pole, #6, #7

Step 2: After choosing your layout, excavate (9) 10" Diameter holes, at 36" deep.

Step 3 (Optional): Pound 18" of 36" long Steel Rebar (not provided) into the center of each hole. This process helps with keeping the Chimes vertical while the concrete cures. Place each Chime and Mallet Pole into their hole over the rebar.

Step 4: Place each Chime and Mallet Pole into their hole, then pour concrete around the poles within the holes. Check that everything is level. Leave concrete to set according to the concrete manufacturer's guidelines. If necessary, brace the Chimes to hold them rigid during the curing process. Approximately (27) 80lb. bags will be needed. (Chimes must be as vertical as possible for best sound)

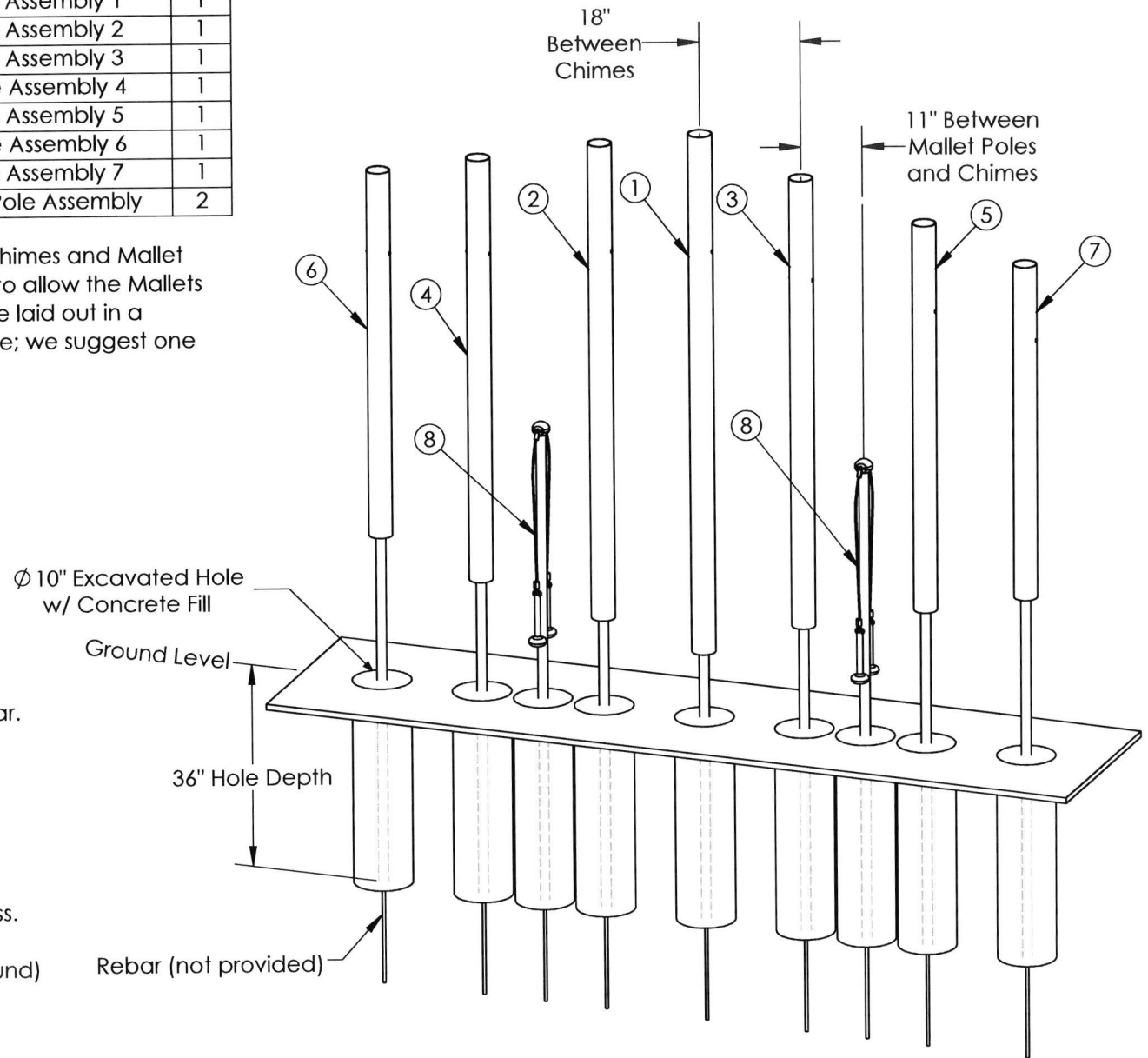

Parts List:

ITEM NO.	DESCRIPTION	QTY.
1	Contrabass Chimes - Surface Mount Chime Assembly 1	1
2	Contrabass Chimes - Surface Mount Chime Assembly 2	1
3	Contrabass Chimes - Surface Mount Chime Assembly 3	1
4	Contrabass Chimes - Surface Mount Chime Assembly 4	1
5	Contrabass Chimes - Surface Mount Chime Assembly 5	1
6	Contrabass Chimes - Surface Mount Chime Assembly 6	1
7	Contrabass Chimes - Surface Mount Chime Assembly 7	1
8	Contrabass Chimes - Surface Mount Mallet Pole, 48" lg.	2
9	3/8"-16 Wedge Expansion Anchor, 3.75"lg. SS	27
10	35/64" Hex Nut Cap	27

Step 1: Determine your layout. Spacing between Chimes and Mallet Poles must be maintained per the diagram shown to allow the Mallets to reach each Chime. Although the Chimes can be laid out in a variety of styles such as an arc, wave, or straight-line; we suggest one of the following layout orders:

#6, #4, Mallet Pole, #2, #1, #3, Mallet Pole, #5, #7

or

#1, #2, Mallet Pole, #3, #4, #5, Mallet Pole, #6, #7

Step 2: Determine installation location. Verify concrete footing is a minimum of 132" long x 18" wide x 6" thick, depending on the layout you go with. If the concrete pad is at an angle, steel washers are required to act as shims (Shims not provided). If there is not already an existing pad, approximately (23) 80lb. bags will be needed. Allow concrete to cure per concrete manufacturers guidelines.

Step 3: With two people place the Chimes and Mallet Poles individually onto the concrete pad and mark the center of the holes on the surface mount plates. After you have made your marks, set aside the Chimes and Mallet poles in order to drill for anchor holes. With a hammer or rotary drill, drill through concrete at marked locations. Drill to a minimum depth of 4". A 3/8" masonry drill bit will be needed.

Step 4: Place the Chimes and Mallet Poles back over the drilled out holes. Insert provided anchor bolts into aligned holes. Position anchor nut so that it is flush with the top of the bolt. Pound anchor bolts into the hole until the anchor washer is flush with the surface mount base. Tighten anchor bolts until they are snug. Cover remaining bolt sections with provided nut caps.

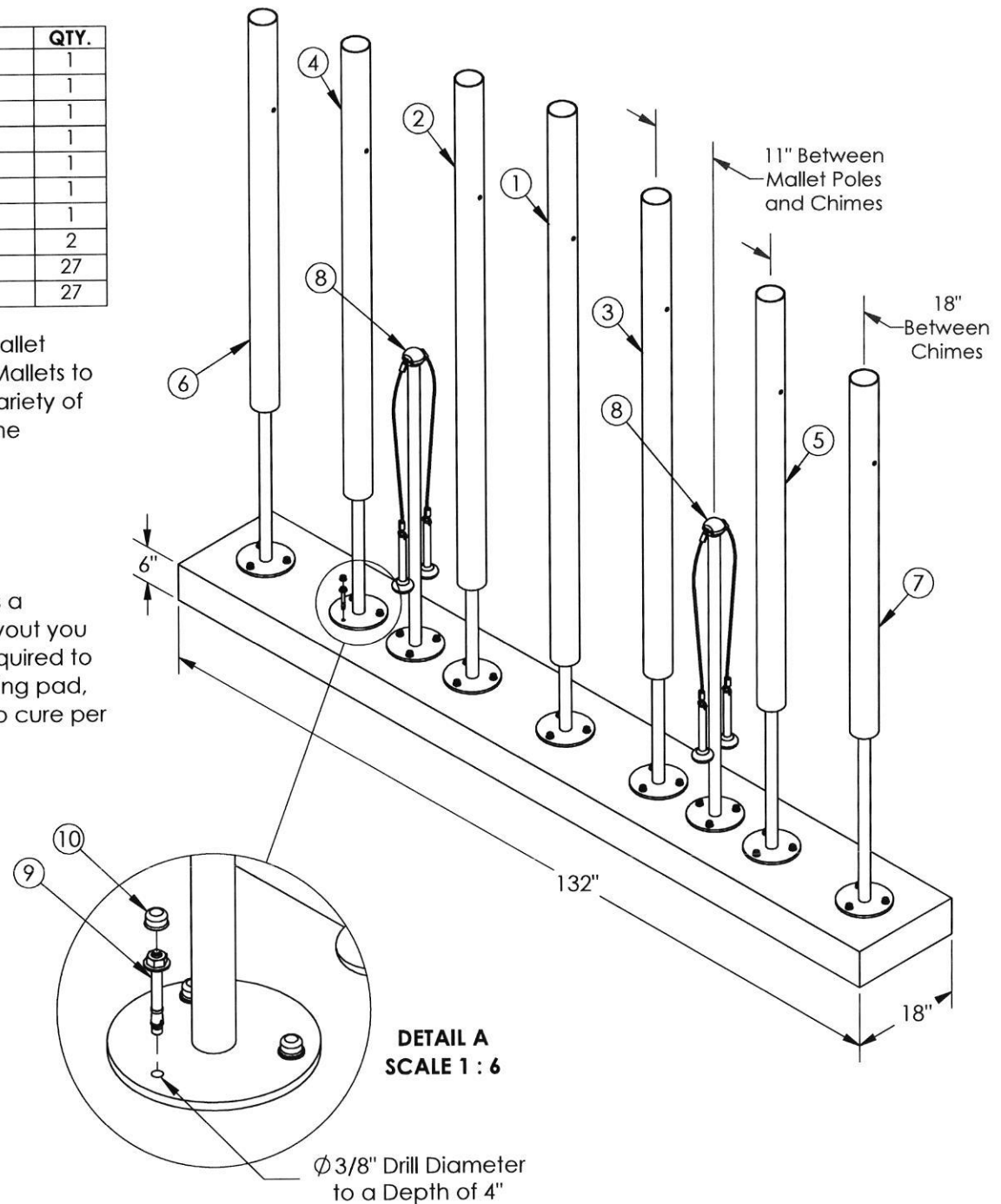

HARP INSTALLATION GUIDE

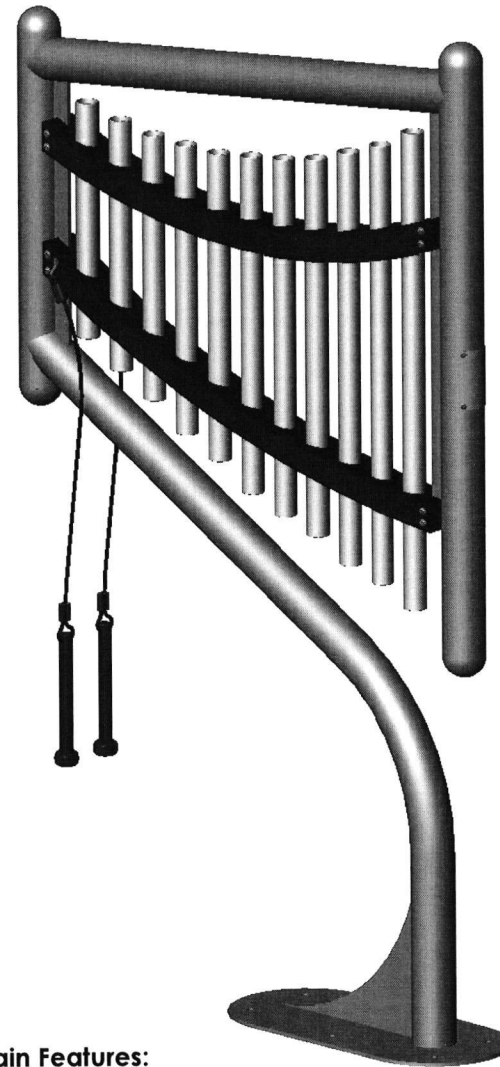
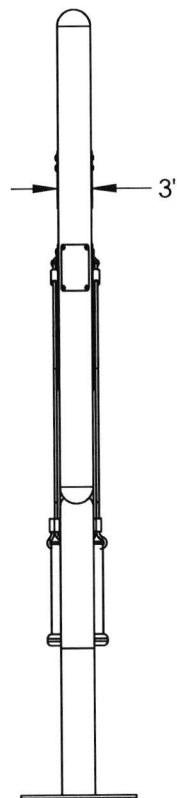
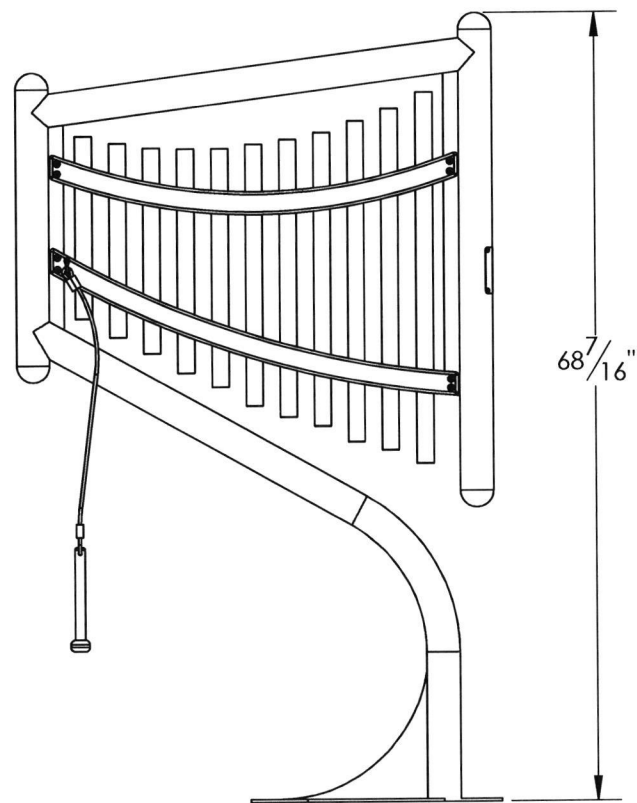
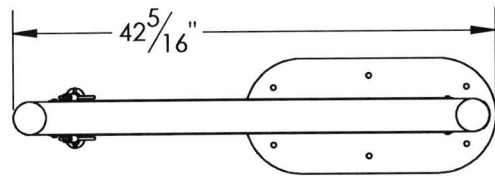

Main Features:

- C Major Pentatonic
- Powder Coated Steel Frame
- Anodized Aluminum Chimes
- Stainless Steel Hardware

Contents:

- SHEET 2 - In Ground and Surface Mount Installation w/ Parts List

Weights:

- Instrument Weight, 111lbs.
- Boxed Instrument Weight, 147lbs.



FREENOTES HARMONY PARK
544 CHESTNUT ST.
CHATTANOOGA, TN 37402
TEL: 833.262.1569

WWW.FREENOTESHARMONYPARK.COM

PROPRIETARY AND CONFIDENTIAL
THE INFORMATION CONTAINED IN THIS
DRAWING IS THE SOLE PROPERTY OF
FREENOTES HARMONY PARK. ANY
REPRODUCTION IN PART OR AS A
WHOLE WITHOUT THE WRITTEN
PERMISSION OF FREENOTES HARMONY
PARK IS PROHIBITED.

TITLE:

Harp - Installation Guide

DWG. NO. HRP-INSTALL

REVISION: A

SCALE: 1:16

DATE: 2/8/2018

SHEET 1 OF 2

Parts List:

ITEM NO.	PART DESCRIPTION	QTY.
1	Harp Instrument Assembly	1
2	3/8"-16 Wedge Expansion Anchor, 3.75"lg. SS	6
3	35/64" Hex Nut Cap	6

Step 1: Determine installation location. Verify concrete footing is a minimum of 36" long x 24" wide x 6" thick. If the concrete pad is at an angle, steel washers are required to act as shims (Shims not provided). If there is not already an existing pad, approximately (5) 80lb. bags will be needed. Allow concrete to cure per concrete manufacturers guidelines. (If a In-Ground appearance is desired recess the concrete pad 4" below finished grade)

Step 2: With two people place the Instrument Assembly onto the concrete pad and mark the center of the holes on the surfacemount plate. After you have made your marks, set aside the Instrument in order to drill for anchor holes. With a hammer or rotary drill, drill through concrete at marked locations. Drill to a minimum depth of 4". A 3/8" masonry drill bit will be needed.

Step 3: Place the Instrument back over the drilled out holes. Insert provided anchor bolts into aligned holes. Position anchor nut so that it is flush with the top of the bolt. Pound anchor bolts into the hole until the anchor washer is flush with the steel base. Tighten anchor bolts until they are snug. Cover remaining bolt sections with provided nut caps.

Step 4: Verify the correct placement, levelness, and finished height of the instrument. Also check for sufficient clearance around the instrument. A 36" perimeter around the instrument is recommended for wheelchair accessibility.

Step 5: If installing onto wet concrete, us the wet set anchor manufacturers guidelines for installation procedures.

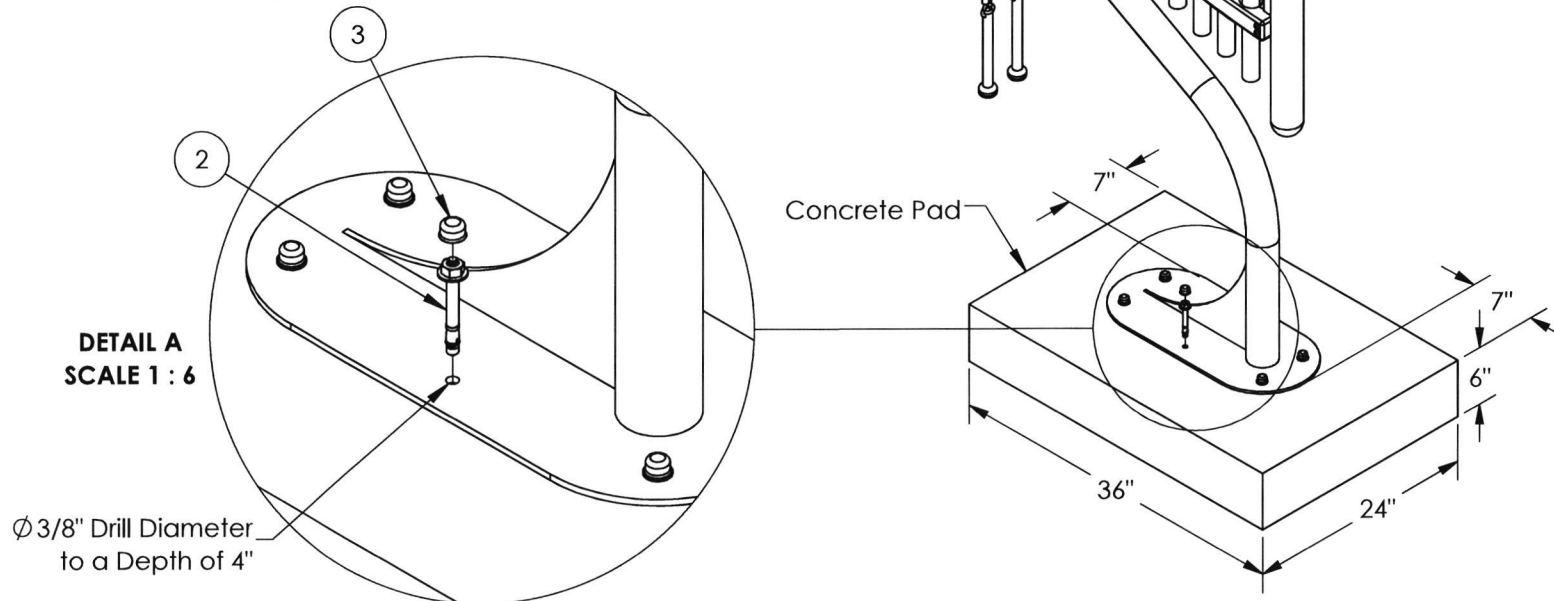

FREENOTES HARMONY PARK
544 CHESTNUT ST.
CHATTAHOOGA, TN 37402
TEL: 833.262.1569

WWW.FREENOTESHARMONYPARK.COM

PROPRIETARY AND CONFIDENTIAL
THE INFORMATION CONTAINED IN THIS
DRAWING IS THE SOLE PROPERTY OF
FREENOTES HARMONY PARK. ANY
REPRODUCTION IN PART OR AS A
WHOLE WITHOUT THE WRITTEN
PERMISSION OF FREENOTES HARMONY
PARK IS PROHIBITED.

TITLE:
In Ground and Surface Mount Installation
with Parts List

DWG. NO. HRP-INSTALL

REVISION: A

SCALE: 1:16

DATE: 2/8/2018

SHEET 2 OF 2

LILYPAD CYMBALS INSTALLATION GUIDE

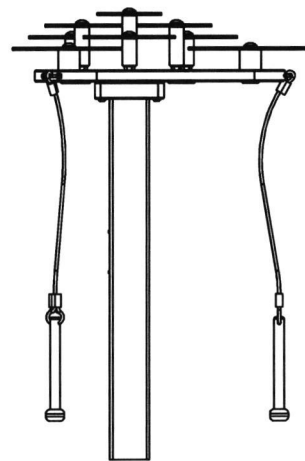
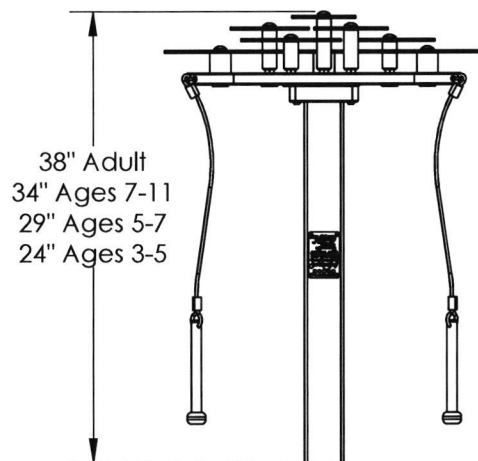
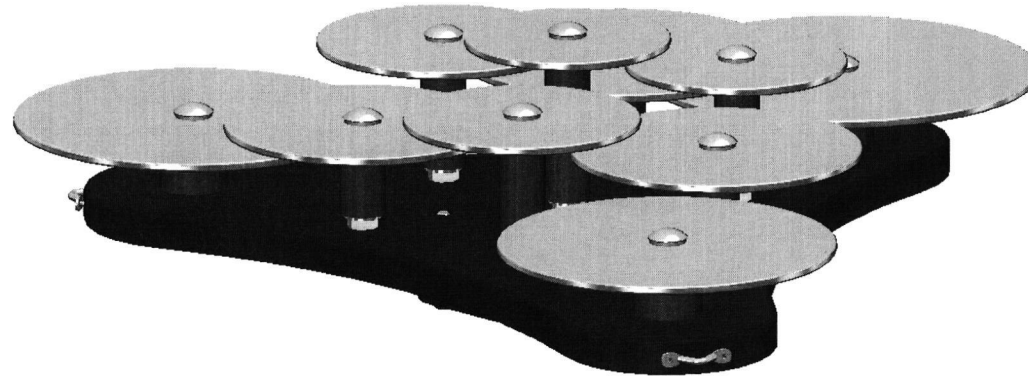
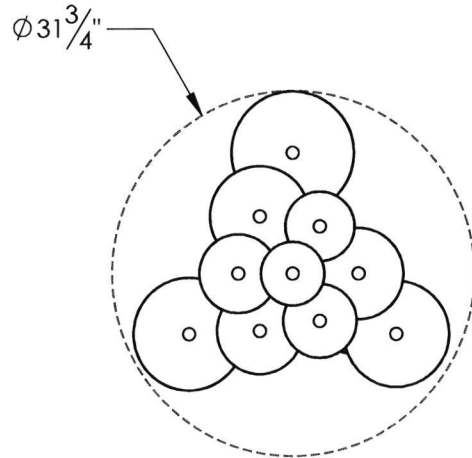

Main Features:

- C Major Pentatonic
- Recycled HDPE Frame
- Anodized Aluminum Cymbals
- Stainless Steel Hardware

Contents:

- SHEET 2 - Parts List and Instrument to Post Installation
- SHEET 3 - In Ground Installation
- SHEET 4 - Surface Mount Installation

Weights:

- Instrument Weight, 28lbs.
- Boxed Instrument Weight, 35lbs.
- Boxed Post Weight, 20l-36lbs.

TITLE:

Lilypad Cymbals - Installation Guide

DWG. NO. LPAD-INSTALL

REVISION: B

SCALE: 1:16

DATE: 12/7/2018

SHEET 1 OF 4

Parts List:

ITEM NO.	PART NUMBER	DESCRIPTION	In Ground Recycled QTY.	In Ground Steel QTY.	Surface Mount Recycled QTY.	Surface Mount Steel QTY.
1	LPAD-BOM	Pre-Assembly - Lilypad Cymbals Instrument	1	1	1	1
2	POST-REC-68-DEG0-SIGN	In Ground Recycled Post, 68"lg. w/ Name Plate	1	-	-	-
3	LPAD-IG-POST-STL-SIGN	Lilypad Cymbals - In Ground Steel Post, 67"lg. w/ Name Plate (Powder-coated)	-	1	-	-
4	POST-REC-32-DEG0-SIGN	Surface Mount Recycled Post, 32"lg. w/ Name Plate	-	-	1	-
5	LPAD-SM-POST-STL-SIGN	Lilypad Cymbals - Surface Mount Steel Post, 31"lg. w/ Name Plate (Powder-coated)	-	-	-	1
6	SM-BASE-REC	Surface Mount Base, For Recycled Post	1	1	2	1
7	316.2500TBSS	3/8"-16 Button Head Screw, 2.5"lg. SS, T45 temp	4	4	4	4
8	31N500BHLS	5/16" Hex Head Lag Bolt, 5"lg. SS	2	-	4	-
9	9267K43	35/64" Hex Nut Cap	-	-	4	4
10	POW 07316	3/8"-16 Wedge Expansion Anchor, 5"lg. SS	-	-	4	-
11	POW 07315	3/8"-16 Wedge Expansion Anchor, 3.75"lg. SS	-	-	-	4
12	12265	T40 x 1" Driver	1	1	1	1

Step 1 (Recycled Post Only): Install one of the Surface Mount Bases to the top of the Post. Align the holes on the Base with the holes on the Post. Fasten them together with the provided 5/16" Hex Head lag Bolts.

Step 2 : Align Post holes and/or Surface Mount Base holes with the holes on the bottom of the Instrument Assembly. Fasten the Post to the Instrument with the provided (4) 3/8"-16 Button Head Screws and Security Driver.

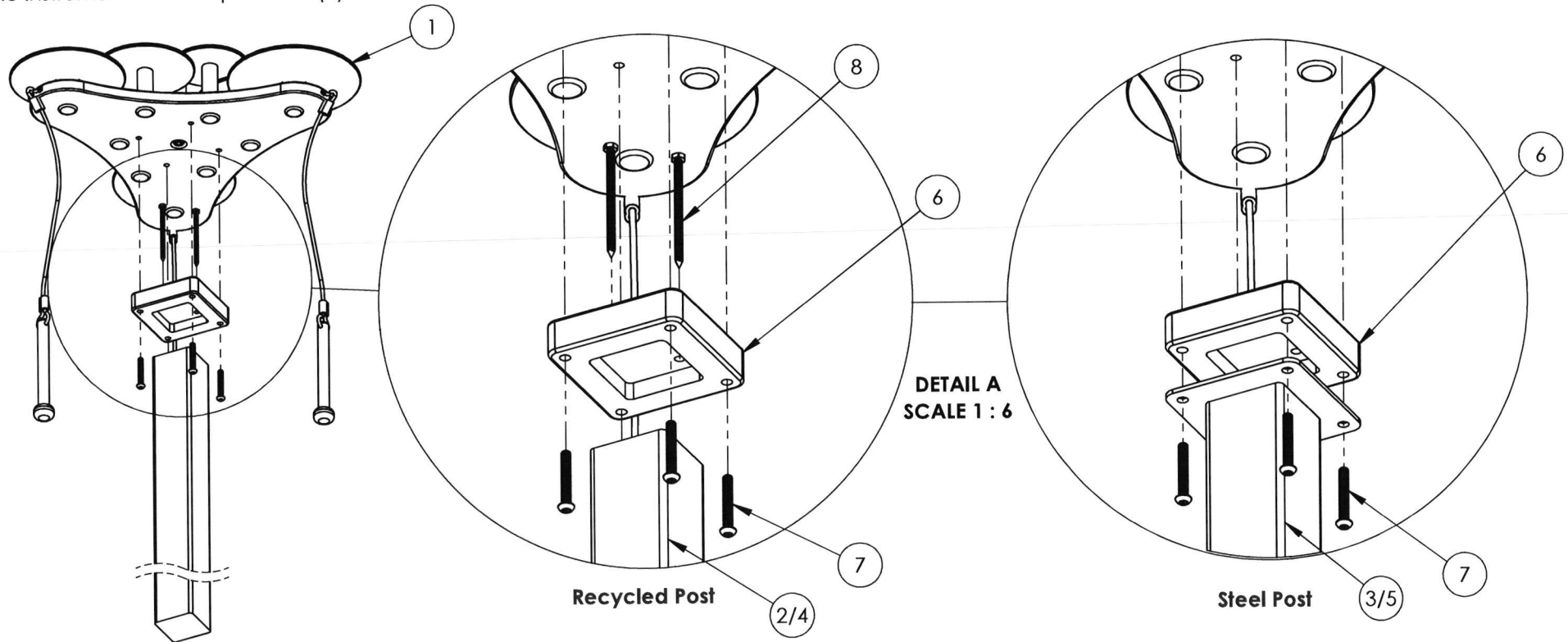

Step 1: Excavate one 10" diameter hole, 36" deep, at the installation location.
Contractor can modify Post to desired height.
Post Length = Frost Depth (36" Recommended) + Finished Post Height

Finished Post Height Guideline: (Ages 3-5, 18") (Ages 5-7, 23") (Ages 7-11, 28") (Adult, 32")

Step 2: With two people, lower the Post with the Instrument attached into the excavated hole.

Step 3: Verify the correct placement, levelness, and finished height of the Instrument.
Check for sufficient clearance around the Instrument, a 36" perimeter around the Instrument is recommended for wheelchair accessibility.

Step 4: Last pour concrete around the post. It is recommended to brace the Instrument to hold it rigid while the concrete cures. Leave to set according to the concrete manufacturers guidelines. Approximately (3) 80lb. bags will be needed.

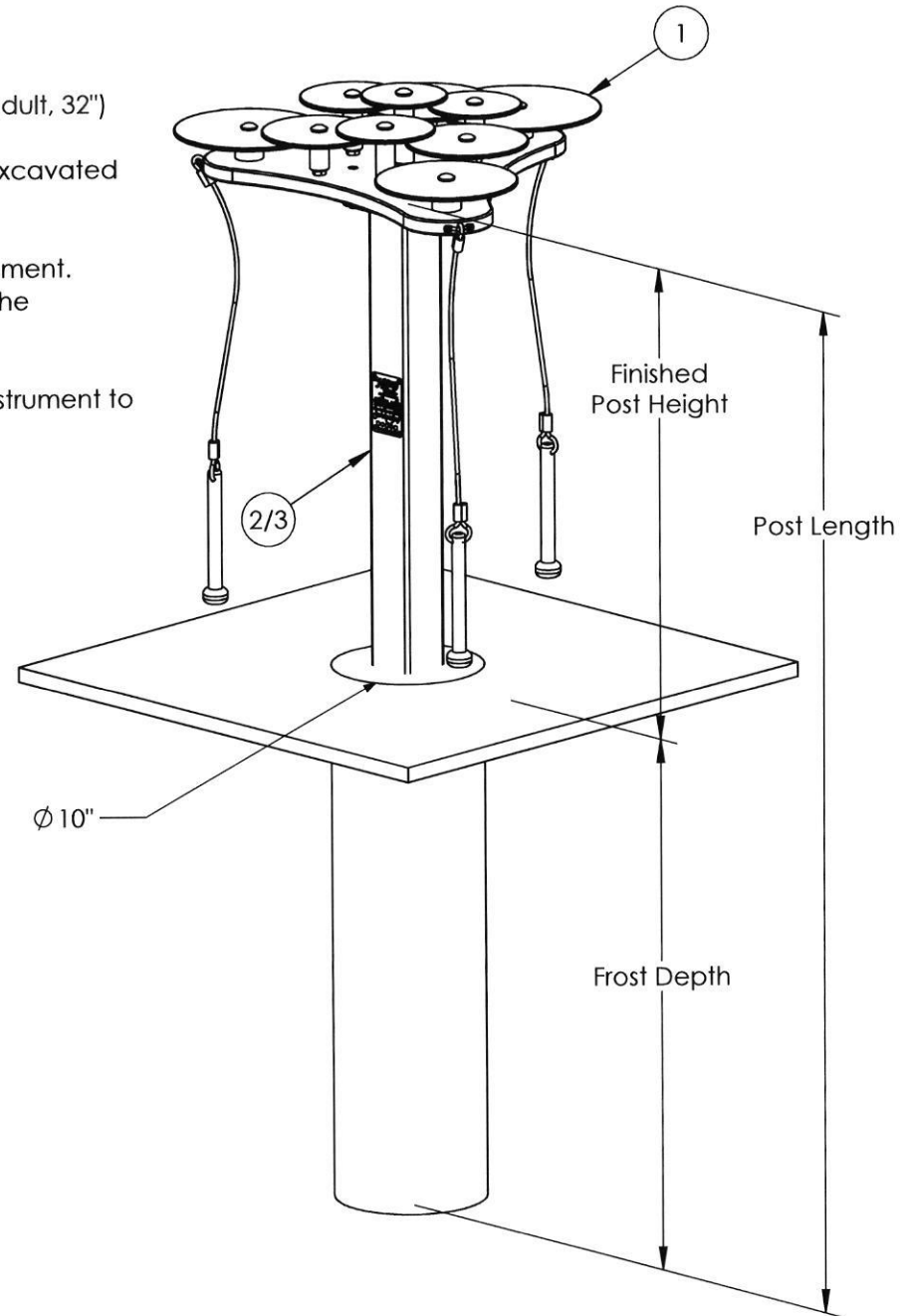

Step 1: Standard height for Surface Mount Posts are 36". The Recycled Post may be modified in the field to the following heights:

(Ages 3-5, 18") (Ages 5-7, 23") (Ages 7-11, 28") (Adult, 32")

The height of Surface Mount Steel Posts can not be adjusted.

Step 2: Determine installation location. Verify concrete footing is a minimum of 24" long x 24" wide x 6" thick. If the concrete pad is at an angle, steel washers are required to act as shims (Shims not provided). If there is not already an existing pad, approximately (4) 80lb. bags will be needed. Allow concrete to cure per concrete manufacturers guidelines.

Step 3 (Recycled Post Only): Install the Surface Mount Base to the bottom of the Post. Align the holes on the Base with the holes on the Post. The Base should fit snugly around the Post. Fasten them together with the provided 5/16" Hex Head Lag Bolts.

Step 4: With two people place the Instrument Assembly with Post attached onto the concrete pad and mark the center of the holes on the surface mount base. After you have made your marks, set aside the Instrument in order to drill for anchor holes. With a hammer or rotary drill, drill through concrete at marked locations. Drill to a minimum depth of 4". A 3/8" masonry drill bit will be needed.

Step 5: Place the Instrument back over the drilled out holes. Insert provided anchor bolts into aligned holes. Position anchor nut so that it is flush with the top of the bolt. Pound anchor bolts into the hole until the anchor washer is flush with the surface mount base. Tighten anchor bolts until they are snug. Cover remaining bolt sections with provided nut caps.

Step 6: Verify the correct placement, levelness, and finished height of the Instrument. Check for sufficient clearance around the Instrument, a 36" perimeter around the Instrument is recommended for wheelchair accessibility.

Step 7: If installing onto wet concrete, us the wet set anchor manufacturers guidelines for installation procedures.

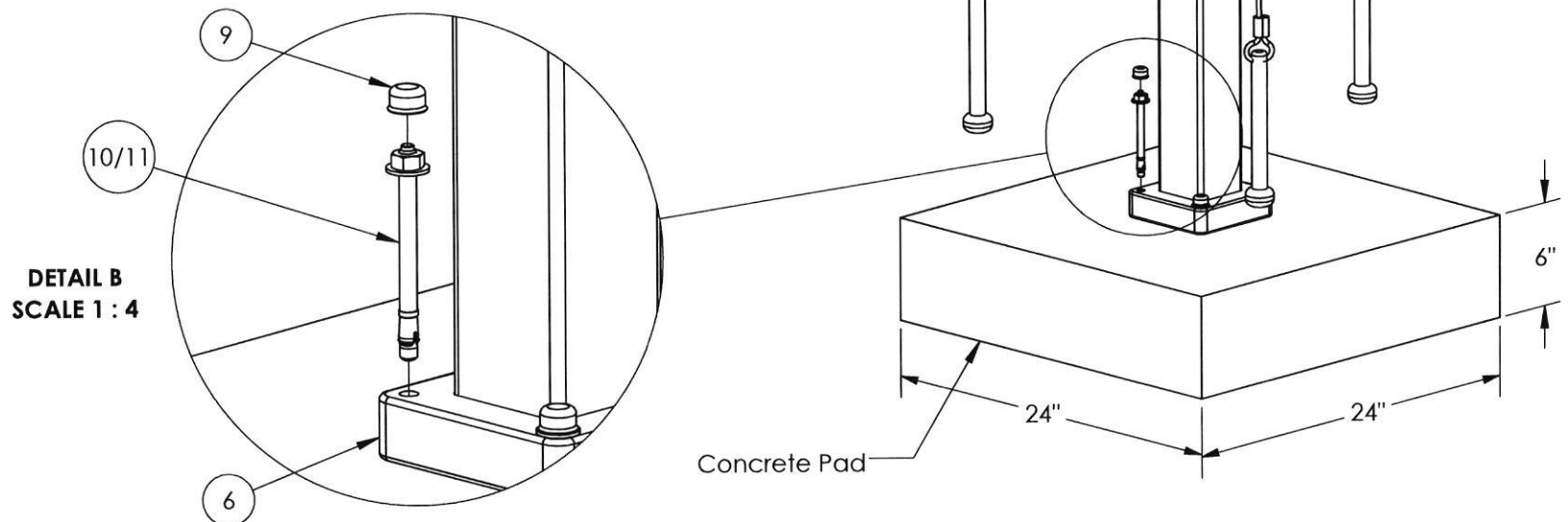

MANTA RAY INSTALLATION GUIDE

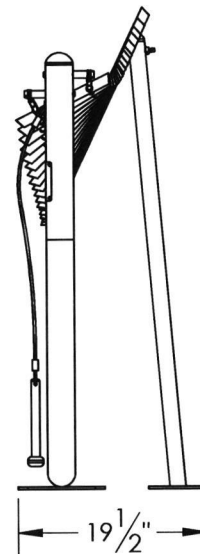
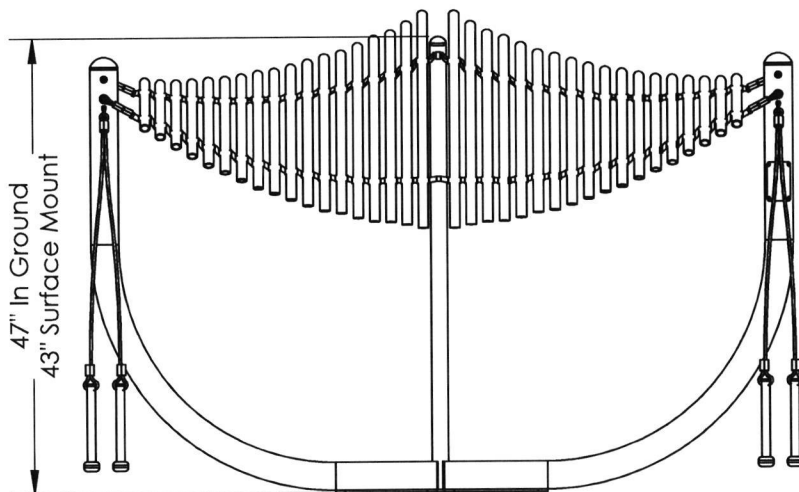
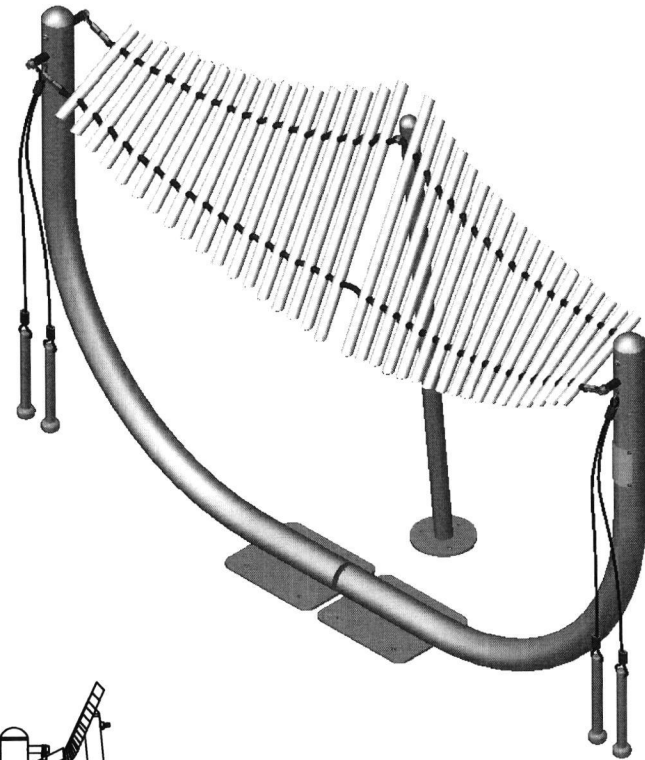
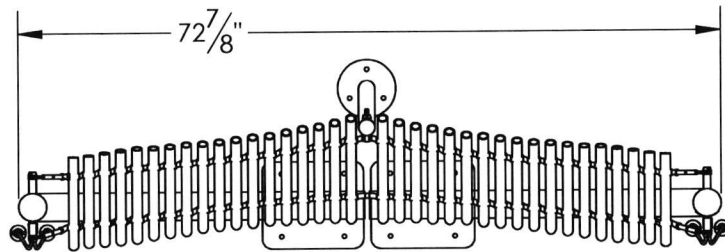

Main Features:

- C Major Diatonic
- Powder Coated Steel Frame
- Anodized Aluminum Chimes
- Stainless Steel Hardware

Contents:

- SHEET 2 - In Ground and Surface Mount Installation w/ Parts List
- SHEET 3 - Chime Installation

Weights:

- Instrument Weight, 116lbs.
- Boxed Instrument Weight, 140lbs.

TITLE:

Manta Ray - Installation Guide

DWG. NO. MRAY-INSTALL

REVISION: A

SCALE: 1:19

DATE: 2/7/2018

SHEET 1 OF 3

Step 1: Determine installation location. Verify concrete footing is a minimum of 36" long x 24" wide x 6" thick. If the concrete pad is at an angle, steel washers are required to act as shims (Shims not provided). If there is not already an existing pad, approximately (5) 80lb. bags will be needed. Allow concrete to cure per concrete manufacturers guidelines. (If a In-Ground appearance is desired recess the concrete pad 4" below finished grade)

Step 2: With two people place the Uprights individually onto the concrete pad and mark the center of the holes on the surface mount plates. Use the diagram below as a guide for Upright placements. After you have made your marks, set aside the Uprights in order to drill for anchor holes. With a hammer or rotary drill, drill through concrete at marked locations. Drill to a minimum depth of 4". A 3/8" masonry drill bit will be needed.

Step 3: Place the Uprights back over the drilled out holes. Insert provided anchor bolts into aligned holes. Position anchor nut so that it is flush with the top of the bolt. Pound anchor bolts into the hole until the anchor washer is flush with the Upright Bases. Tighten anchor bolts until they are snug. Cover remaining bolt sections with provided nut caps.

Step 4: Verify the correct placement, levelness, and finished height of the instrument. Also check for sufficient clearance around the instrument. A 36" perimeter around the instrument is recommended for wheelchair accessibility.

Step 5: If installing onto wet concrete, us the wet set anchor manufacturers guidelines for installation procedures.

Parts List:

ITEM NO.	PART DESCRIPTION	QTY.
1	Steel Outer Upright	2
2	Steel Inner Upright	1
3	3/8"-16 Wedge Expansion Anchor, 3.75"lg. SS	11
4	35/64" Hex Nut Cap	11
5	Manta Ray Chime Assembly	1
6	3/8"-16 Button Head Screw, 5"lg. SS, Hex Drive	4
7	3/8"-16 Tri-Groove Nut, Zn	5
8	ø13/32" ID x ø7/8" OD, Washer SS	8
9	ø.385" ID x ø3/4" OD Spacer, 1.5"lg. LDPE	4
10	Blue Locktite	1
11	#30 Square-Drive Socket	1



FREENOTES HARMONY PARK
544 CHESTNUT ST.
CHATTANOOGA, TN 37402
TEL: 833.262.1569

WWW.FREENOTESHARMONYPARK.COM

PROPRIETARY AND CONFIDENTIAL
THE INFORMATION CONTAINED IN THIS
DRAWING IS THE SOLE PROPERTY OF
FREENOTES HARMONY PARK. ANY
REPRODUCTION IN PART OR AS A
WHOLE WITHOUT THE WRITTEN
PERMISSION OF FREENOTES HARMONY
PARK IS PROHIBITED.

TITLE:
In Ground and Surface Mount Installation
with Parts List

DWG. NO. MRAY-INSTALL

REVISION: A

SCALE: 1:16

DATE: 2/7/2018

SHEET 2 OF 3

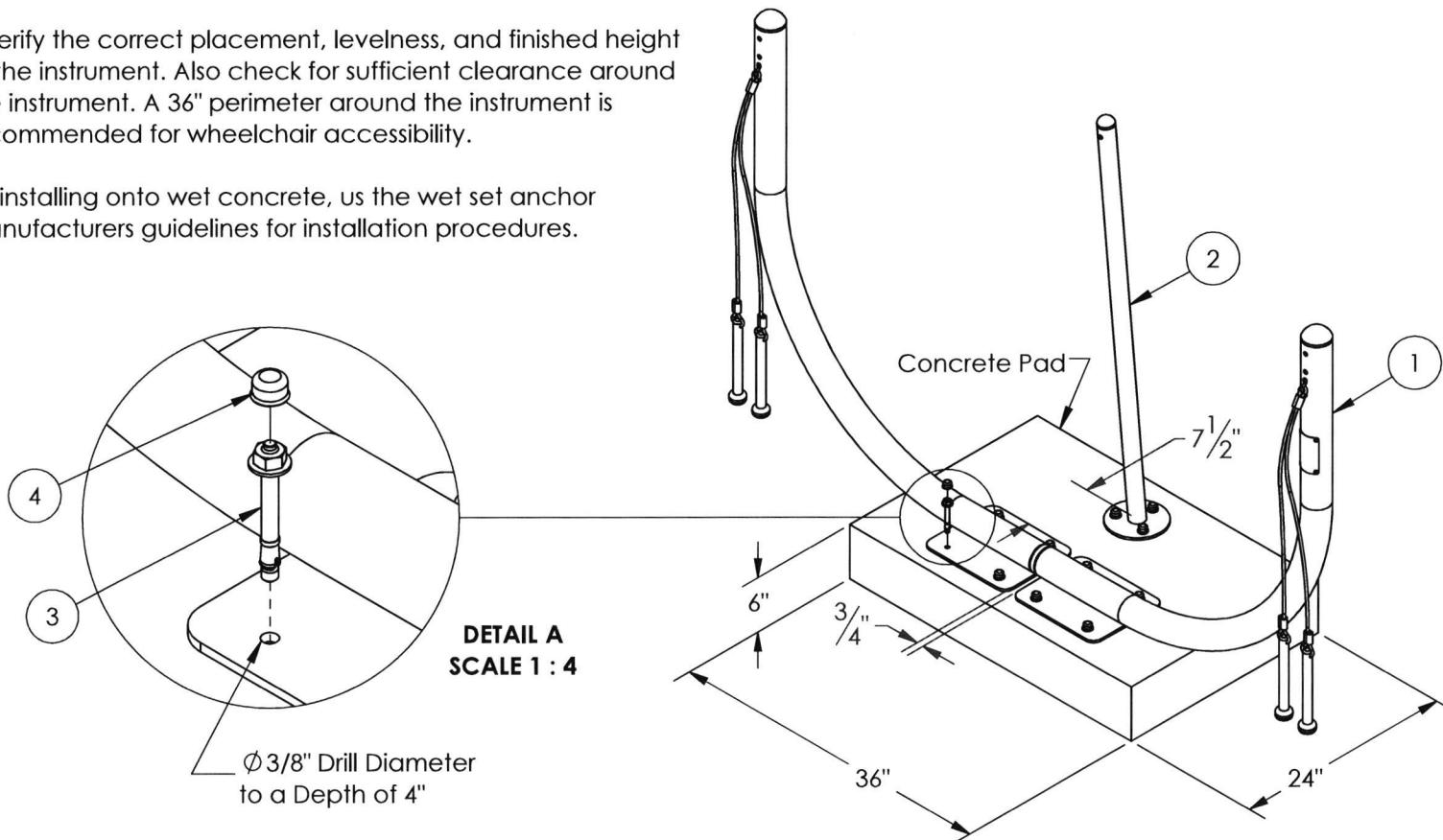

Step 1: After the Inner and Outer Uprights have been properly installed attach the Chime Assembly to the Uprights.

Step 2: Follow the diagrams below for installation of the Chime Assembly. Before installing the tamper-resistant nuts, apply the provided blue locktite to the threads of of the 5 bolts on the Chime Assembly. After the blue locktite is applied, fasten down nuts with the provided #30 Square-Drive Socket.

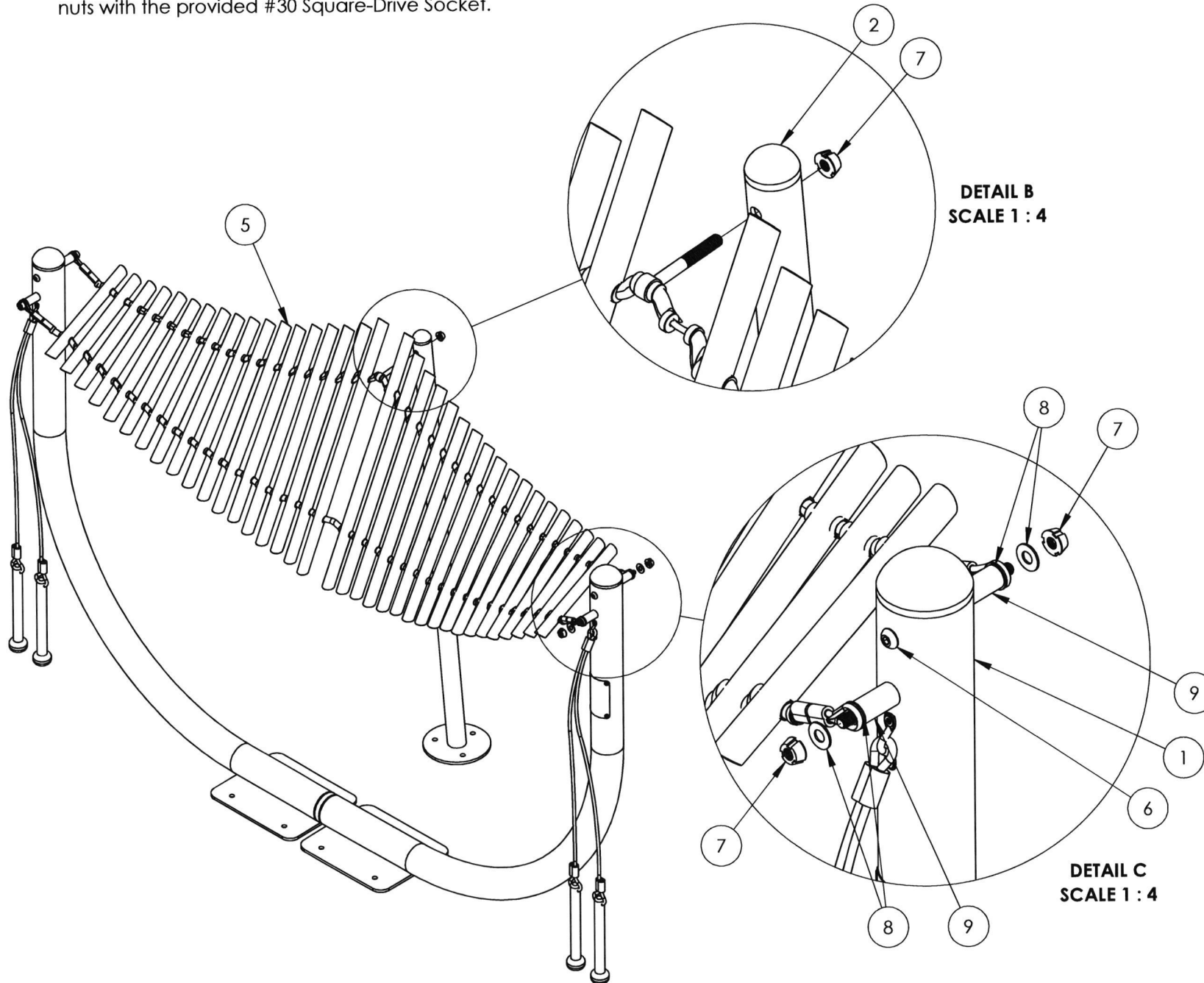

TITLE:
Chime Installation

DWG. NO. MRAY-INSTALL

REVISION: A

SCALE: 1:12

DATE: 2/7/2018

SHEET 3 OF 3

PAGODA BELLS INSTALLATION GUIDE

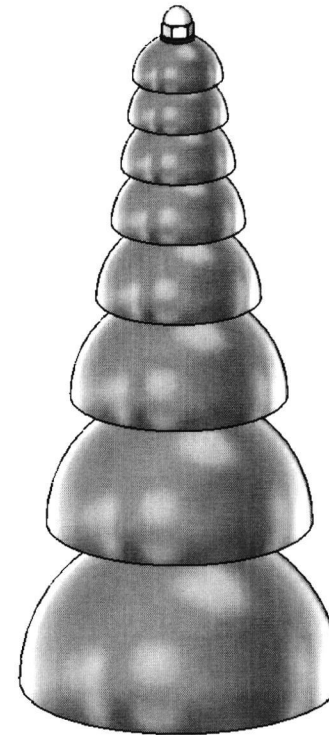
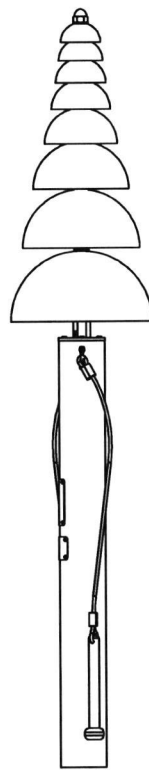
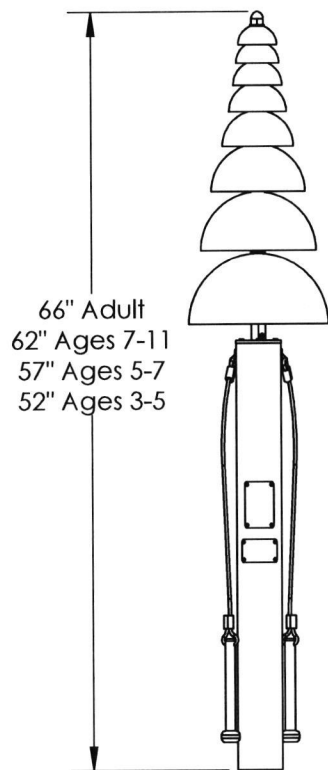
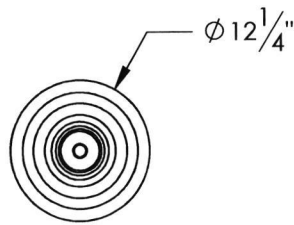

Main Features:

- Stainless Steel Bells
- Stainless Steel Hardware

Contents:

- SHEET 2 - Parts List and Instrument to Post Installation
- SHEET 3 - In Ground Installation
- SHEET 4 - Surface Mount Installation

Weights:

- Instrument Weight, 20lbs.
- Boxed Instrument Weight, 27lbs.
- Boxed Post Weight, 28-38lbs.

TITLE:

Pagoda Bells - Installation Guide

DWG. NO. PBEL-INSTALL

REVISION: B

SCALE: 1:16

DATE: 3/22/2018

SHEET 1 OF 4

Parts List:

ITEM NO.	PART DESCRIPTION	In Ground - Recycled Post/QTY.	In Ground - Steel Post/QTY.	Surface Mount - Recycled Post/QTY.	Surface Mount - Steel Post/QTY.
1	Pagoda Bells Instrument Assembly	1	1	1	1
2	In Ground Recycled Post, 73"lg.	1	-	-	-
3	In Ground Steel Post, 73"lg.	-	1	-	-
4	Surface Mount Recycled Post, 37"lg.	-	-	1	-
5	Surface Mount Steel Post, 37"lg.	-	-	-	1
6	Surface Mount Base	-	-	1	-
7	1/4"-20 Button Head Screw, .5"lg. SS, T27 tamp	1	1	1	1
8	5/16" Hex Head Lag Bolt, 5"lg. SS	-	-	2	-
9	3/8"-16 Wedge Expansion Anchor, SS	-	-	4	4
10	35/64" Hex Nut Cap	-	-	4	4
11	Security Driver	1	1	1	1

Step 1: Thread the Pagoda Bells Instrument Assembly's Threaded Rod into the Threaded Rod Support on the Instrument Post. Tighten down until the Stop Nut makes contact with the Threaded Rod Support.

Step 2: Take the 1/4"-20 Button Head Screw with Security Driver and thread it through the Threaded Rod Support all the way into the Threaded Rod. This secures the Instrument Assembly so that it can not be backed out.

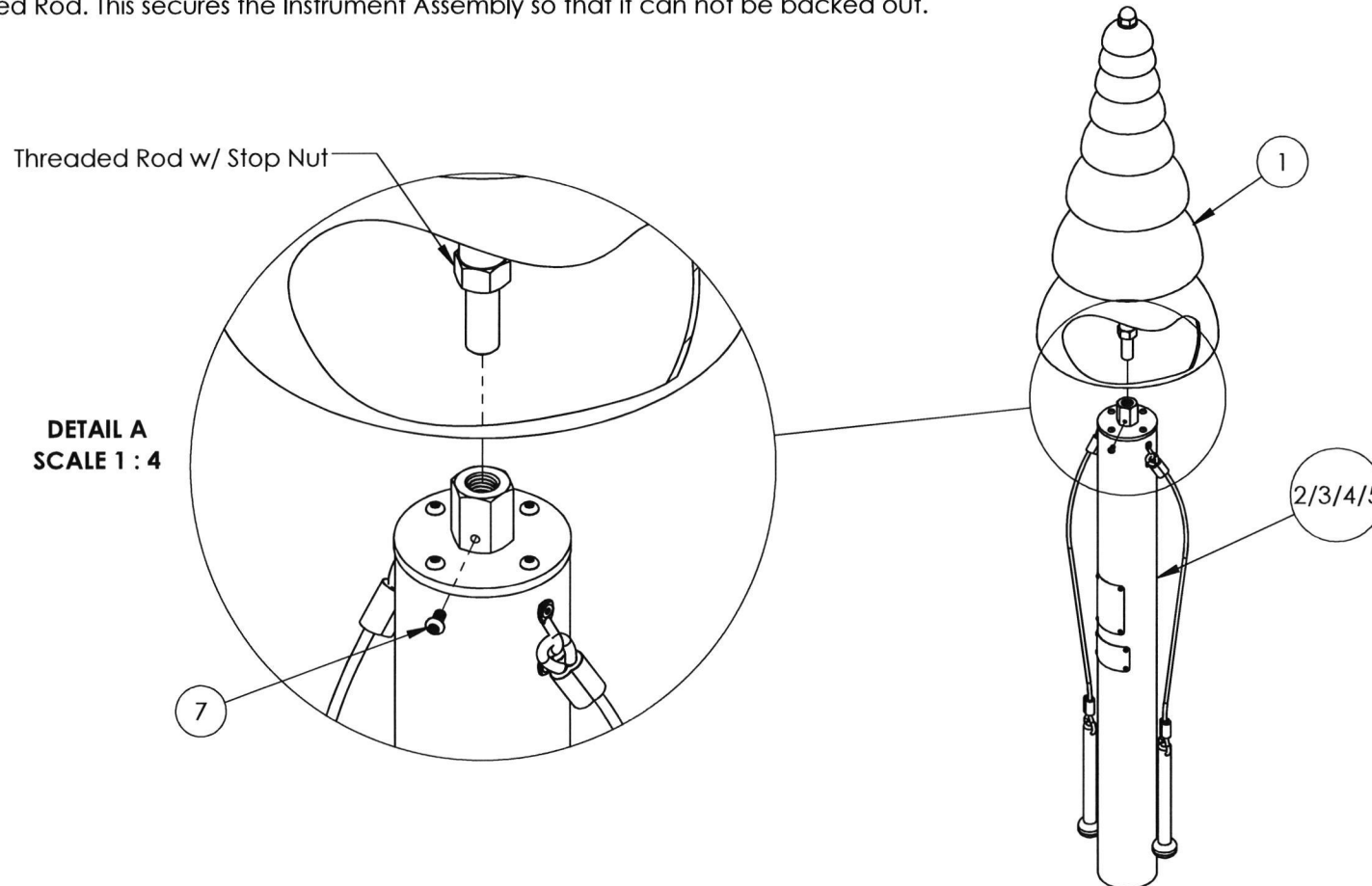

FREENOTES HARMONY PARK
544 CHESTNUT ST.
CHATTANOOGA, TN 37402
TEL: 833.262.1569

WWW.FREENOTESHARMONYPARK.COM

PROPRIETARY AND CONFIDENTIAL
THE INFORMATION CONTAINED IN THIS DRAWING IS THE SOLE PROPERTY OF FREENOTES HARMONY PARK. ANY REPRODUCTION IN PART OR AS A WHOLE WITHOUT THE WRITTEN PERMISSION OF FREENOTES HARMONY PARK IS PROHIBITED.

TITLE:
Parts List and Instrument to Post Installation

DWG. NO. PBEL-INSTALL

REVISION: B

SCALE: 1:12

DATE: 3/22/2018

SHEET 2 OF 4

Step 1: Excavate one 10" diameter hole, 36" deep at the installation location. Contractor can modify post to desired height.
Post Length = Frost Depth (36" Recommended) + Finished Height

Finished Height Guideline: (Ages 3-5, 23") (Ages 5-7, 28") (Ages 7-11, 33") (Adult, 37")

Step 2: With two people, lower the Post with the Instrument attached into the excavated hole.

Step 3: Verify the correct placement, levelness, and finished height of the Instrument. Check for sufficient clearance around the Instrument, a 36" perimeter around the Instrument is recommended for wheelchair accessibility.

Step 4: Last pour concrete around the Post. It is recommended to brace the Instrument to hold it rigid while the concrete cures. Leave to set according to the concrete manufacturers guidelines. Approximately (3) 80lb. bags will be needed.

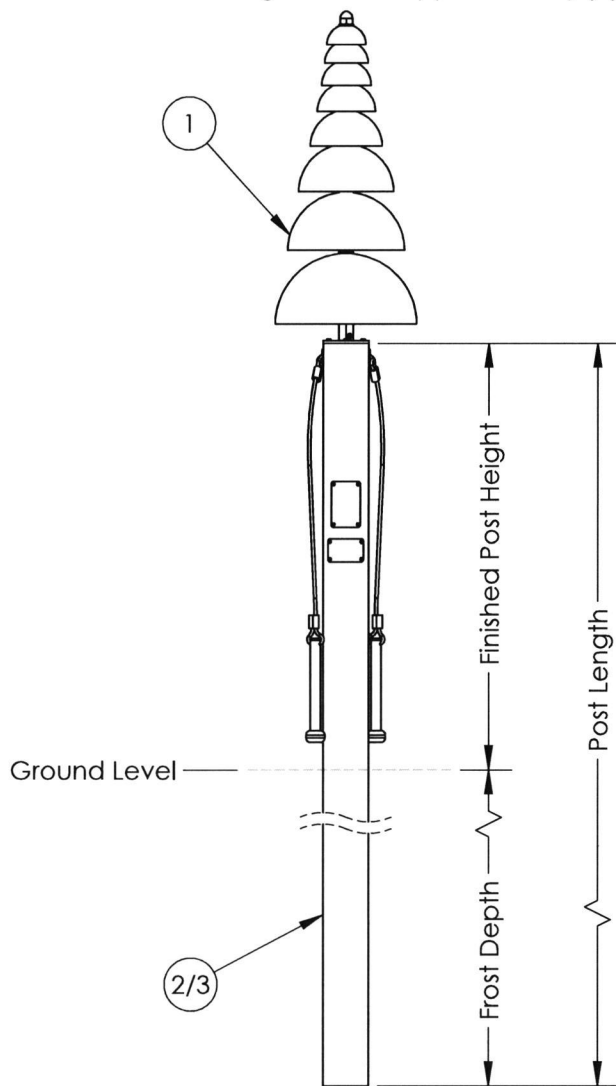

TITLE:

In Ground Installation

DWG. NO. PBEL-INSTALL

REVISION: B

SCALE: 1:16

DATE: 3/22/2018

SHEET 3 OF 4

Step 1: Standard height for Surface Mount Posts are 37". The Recycled Posts may be modified in the field to the following heights:
 (Ages 3-5, 23") (Ages 5-7, 28") (Ages 7-11, 33") (Adult, 37")
 The height of Surface Mount Steel Posts can not be adjusted.

Step 2: Determine installation location. Verify concrete footing is a minimum of 24" long x 24" wide x 6" thick. If the concrete pad is at an angle, steel washers are required to act as shims (Shims not provided). If there is not already an existing pad, approximately (4) 80lb. bags will be needed. Allow concrete to cure per concrete manufacturers guidelines.

Step 3 (Recycled Post Only): Install the Surface Mount Base to the bottom of the Post. Align the holes on the Base with the holes on the Post. The Base should fit snugly around the Post. Fasten them together with the provided 5/16" Hex Head Log Bolts.

Step 4: With two people place the Instrument Assembly with Post attached onto the concrete pad and mark the center of the holes on the Surface Mount Base. After you have made your marks, set aside the Instrument in order to drill for anchor holes. With a hammer or rotary drill, drill through concrete at marked locations. Drill to a minimum depth of 4". A 3/8" masonry drill bit will be needed.

Step 5: Place the Instrument back over the drilled out holes. Insert provided anchor bolts into aligned holes. Position anchor nut so that it is flush with the top of the bolt. Pound anchor bolts into the hole until the anchor washer is flush with the Surface Mount Base. Tighten anchor bolts until they are snug. Cover remaining bolt sections with provided nut caps.

Step 6: Verify the correct placement, levelness, and finished height of the Instrument. Check for sufficient clearance around the Instrument, a 36" perimeter around the Instrument is recommended for wheelchair accessibility.

Step 7: If installing onto wet concrete, us the wet set anchor manufacturers guidelines for installation procedures.

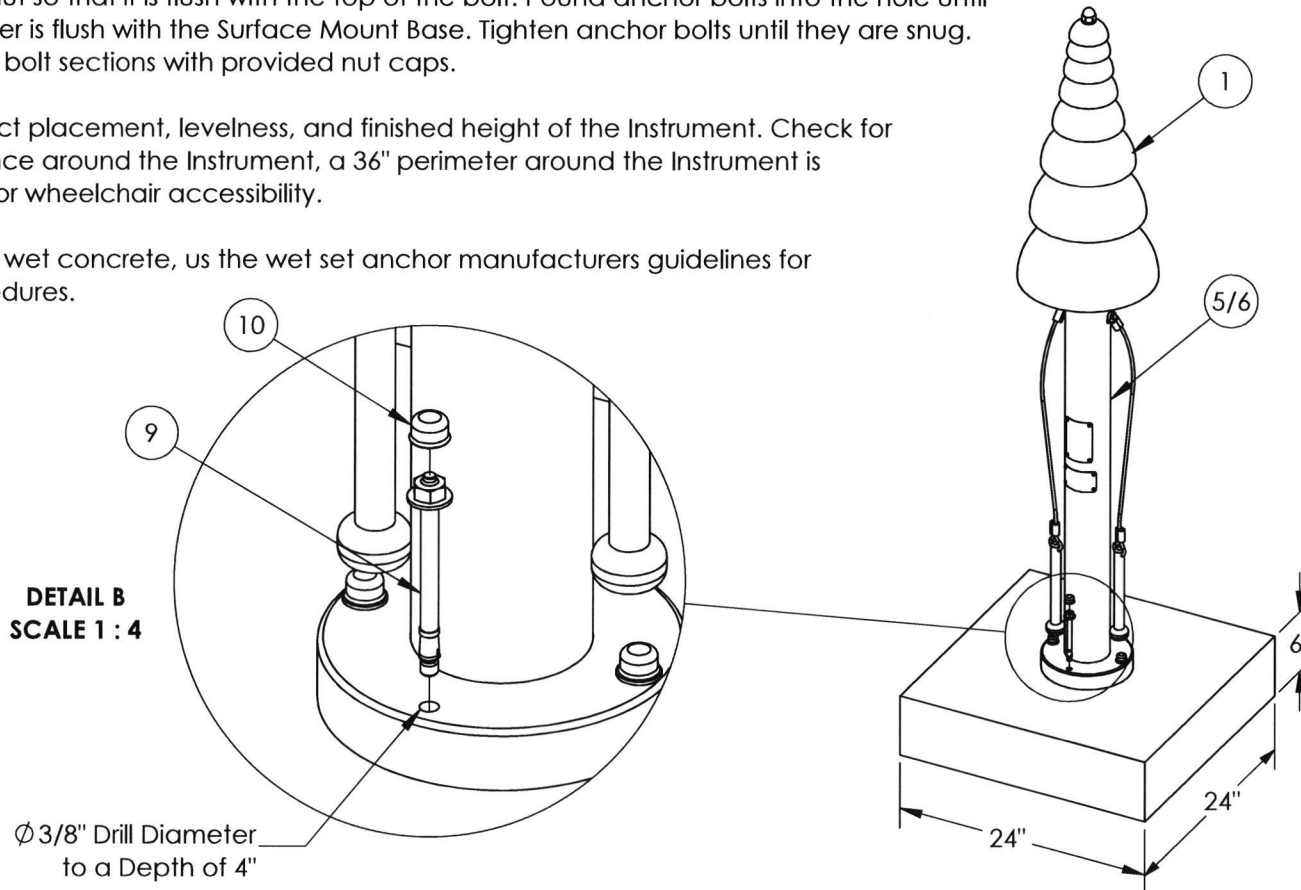

FREENOTES HARMONY PARK
 544 CHESTNUT ST.
 CHATTANOOGA, TN 37402
 TEL: 833.262.1569

WWW.FREENOTESHARMONYPARK.COM

PROPRIETARY AND CONFIDENTIAL
 THE INFORMATION CONTAINED IN THIS
 DRAWING IS THE SOLE PROPERTY OF
 FREENOTES HARMONY PARK. ANY
 REPRODUCTION IN PART OR AS A
 WHOLE WITHOUT THE WRITTEN
 PERMISSION OF FREENOTES HARMONY
 PARK IS PROHIBITED.

TITLE:
 Surface Mount Installation

DWG. NO. PBELL-INSTALL

REVISION: B

SCALE: 1:16

DATE: 3/22/2018

SHEET 4 OF 4