

- *Truck Mounted*
- *LED AllInGaP Technology*
- *Hundreds of pre-programmed messages, MUTCD symbols, and operator-created messages*
- *Up to 3 lines and 12 characters*
- *Color Touch Tablet*
- *Cost Effective*
- *Reliable and easy to operate*
- *High torque electric motor*
- *Meet or exceed all state and federal highway MUTCD traffic safety specifications*
- *Replace characters without the need for tools*



Control

Type	Handheld/removable
Dimming	Manual or automatic
Photo electric sensor	Mounted away from extraneous light
NTCIP communications	Supported
Mounting	On pedestal with separate lift switch

Fonts

TM 200	TM 300
7.5" H 10/line (3) lines	7.5" H 10/line (3) lines
11.5" H 6/line (2) lines	10" H 9/line (3) lines
24" H 3/line (1) line	11.5" H 9/line (3) line
10" H 8/line (2) lines	24" H 3/line (1) lines

Options

- 1/8" clear polycarbonate sign window
- Custom paint - colors to meet specs
- Anti-graffiti coating on window

Mounting Frame

TM 300	50"h x 88"w x 9"dp
TM 200	38"h x 75"w x 9"dp
Frame	1" x 2" x .120 wall steel tube
Pivots	Sealed bearing pillow blocks

Sign Panel

- Full Matrix LED:

TM 200 20 pixels high by 40 pixels wide, up to 3 lines by
10 characters maximum depending on font

TM 300 28 pixels high by 48 pixels wide, up to 4 lines by
12 characters maximum depending on font

- 590 nm (amber) light output LED AllnGaP technology
- 4 LED/Pixel standard, 1.5" x 1.75" pixel spacing
- Store over 300 pre-programmed permanent messages and operator-created messages
- Moving arrows, chevrons and other graphics with auto-centering of messages
- Cables and connectors for connecting to vehicle battery power are included
- Unique "stay tight" snap-in characters
- Positive locking mechanism in raised and lowered positions with dual electric actuators
- Long-lasting powder coat finish

Raised height (from base to top of sign):

TM 200 46" (116.8 cm)

TM 300 58" (147.3 cm)

Lowered height (from base to top of sign):

TM 200 15" (38.1 cm)

TM 300 15" (38.1 cm)

Mounting width:

TM 200 85" (215.9 cm)

TM 300 98" (248.9 cm)

Gross Weight:

TM 200 250 lb. (113.4 kg)

TM 300 300 lb. (136 kg)

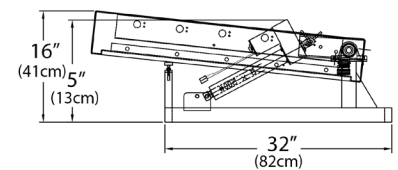
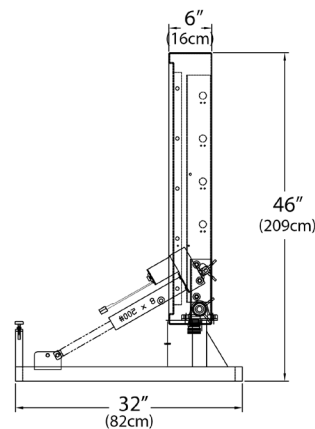
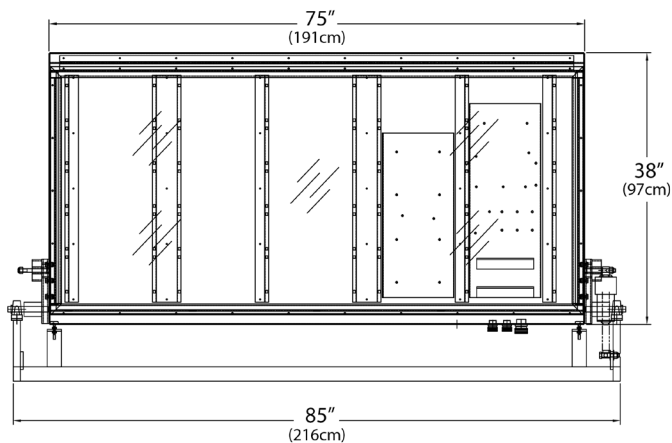

Specifications subject to change any time without notice. Copyright 2016 National Signal, Inc. All rights reserved. Printed in the United States.