

SIGN STANDARDS AND PERMITS

Purpose and goals.

(a) The purpose of this chapter is to provide uniform sign standards that perform the following:

- (1) Promote a positive image of the city;
- (2) Protect an important aspect of the economic base;
- (3) Reduce the confusion and hazards that result from excessive and prolific use of sign displays;
- (4) Ensure that no hazard is created due to collapse, wind, fire, collision, decay or abandonment; that no obstruction is created to fire fighting and police surveillance; and no traffic hazard is created by confusing or distracting motorists, or by impairing the driver's ability to see pedestrians, obstacles, or other vehicles, or to read traffic signs;
- (5) Promote efficient transfer of information in sign message by providing that businesses and services may identify themselves; customers and other persons may locate a business or service; and persons exposed to signs are not overwhelmed by the number of messages presented, and are able to exercise freedom of choice to observe or ignore said messages, according to the observer's purpose; and
- (6) Protect the public welfare and enhance the appearance and economic value of the landscape by providing signs that do not interfere with scenic views; do not create a nuisance to persons using the public right-of-ways; do not constitute a nuisance to occupancy of adjacent and contiguous property by their brightness, size, height, or movement; are not detrimental to land or property value; and, contribute to the special character of particular areas or districts within the city, helping the observer to understand the city and orient oneself within it.

(b) By recognizing this purpose, this chapter shall serve to strengthen the economic stability of business, cultural, and residential areas in the city; recognizing that visual clutter leads to decline in the community's appearance, in property values, and in the effectiveness of the signs.

(c) The goals of this chapter are to preserve the integrity of our community, promote pride in our neighborhoods, promote safe egress/ingress on public roadways, and encourage the effectiveness of signs.

(d) In the event of conflicts, actual or perceived, in the terms or requirements of this chapter, the most restrictive interpretation shall apply.

First Amendment rights.

This chapter shall not be construed, applied, interpreted, nor enforced in a manner to violate the First Amendment rights of any person, and the building official shall seek the advice and recommendation of the city attorney prior to taking any action to enforce any provision of this ordinance with respect to any non-commercial sign or speech by any person.

Enforcement.

(a) *Authority.* The building official and the code enforcement officer is hereby authorized and directed to enforce all the provisions of this chapter. For such purposes the building official has the powers of a code enforcement officer.

(b) *Right of entry.* Whenever necessary to make an inspection to enforce any of the provisions of this chapter, or whenever the building official has reasonable cause to believe that there exists in any building or upon any premises any condition which violates the provisions of this chapter, the building official may enter such building or premises at all reasonable times to inspect the same or to perform any duty imposed upon the building official by this chapter. If such building or premises is occupied, the building official shall first present proper credentials and request entry; and if such building or premises is unoccupied, the building official shall first make a reasonable effort to locate the owner or other persons having charge or control of the building or premises and request entry. If such entry is refused, the building official shall have recourse to every remedy provided by law to secure entry.

Definitions.

As used in this chapter, all words shall have the common meaning of such word and the following terms shall have the meaning indicated below unless context clearly indicates otherwise:

Actively being built. The project or subdivision has continuous construction efforts underway to complete the project.

Activities and events sign. An enclosed, marquee-type sign to provide public buildings, churches (limited to places of worship only), and neighborhood associations, herein referred to as "the entity(ies)" the opportunity to post notices of meetings, activities, and other notices of interest to the entity or group it serves. The purpose of this sign is to facilitate communication within the community served by the public buildings and

the churches, and within the larger neighborhoods of fifty homes or more represented by their neighborhood association.

Awning. A shelter constructed of materials on a supporting framework that projects from and is supported by the exterior wall of a building.

Banner. A sign made of fabric or any nonrigid material.

Berm (monument) sign. A sign where the frame of the sign face is set at grade with the ground as a monument or in an earthen berm. There is no clearance between the ground and the sign face.

Billboard. A sign that is defined by industry standards as a billboard, including changeable electronic variable messaging signs, and in the absence of an industry standard definition, billboard shall mean a sign having a height greater than 12 feet and a surface area greater than 378 square feet.

Building official. Any officer or employee, or person, designated by the City Administrator to perform the duties set forth in this ordinance to be performed by the building official.

"Burma Shave" signs. A sign intended to provide information and direction to potential home buyers within a recorded subdivision in which new homes are actively being built.

Canopy. A freestanding structure with a roof but not walls.

Changeable electronic variable message sign. A sign which permits alteration of the sign's message or images by electronic means. This includes a sign using light-emitting diodes (LEDs) or other means of digital display to present a message or images.

Clearance (of a sign). The smallest vertical distance between the grade of the adjacent street curb and the lowest point of any sign, including framework and embellishments, but excluding sign supports.

Commercial. Locations where the principle use of the property is not classified as residential or multifamily.

Construction trade sign. A sign that identifies the architect, engineer, financial institution, builder, or other building trades contractor involved in a construction project at the site where the sign is located.

Curbline. An imaginary line drawn along the outermost part of back of the curb and gutter on either side of a public street, or, if there is no curb and gutter, along the

outermost portion of the paved roadway, or if there is no paved roadway, along the edge of the traveled portion of the roadway.

Directional signs, traffic. An on-premise sign giving directions, instructions, or facility information and which may contain the name or logo of an establishment and no advertising copy, e.g., parking or exit and entrance signs.

Electrical sign. A sign containing electrical wiring, connections, or fixtures, or utilizing electric current, but not including a sign illuminated by an exterior light source.

Electronic message sign. A sign that includes provisions for programmable electronic message changes.

Facade. All building wall elevations, including any vertical extension of the building wall (parapet), but not including any part of the building roof.

Face or surface. The surface of the sign upon, against, or through which the message is displayed or illustrated on the sign.

Flashing. To light intermittently. To change colors intermittently in order to achieve a flashing, fluttering, scrolling, undulating, or rolling affect (i.e. LED displays). Scrolling of text in a single color is not considered to be flashing.

Freestanding sign. A sign that is not attached to a building but is permanently attached to the ground.

Frontage. A boundary line separating the public right-of-way from the lot.

Future development signs (temporary construction, real estate, or development sign). A freestanding or wall sign advertising the construction, remodeling, development, sale, or lease of a building or the land on which the sign is located.

Government sign. A sign installed, maintained, or used:

(1) By a city, county, state or the federal government, required or specifically authorized for the public purpose pursuant to regulations promulgated by the state or federal government;

(2) By the City of Glen Rose.

Gross surface area. The entire area within a single continuous perimeter enclosing the extreme limits of each sign. A sign having two surfaces shall be considered a single sign if both the surfaces are located back to back. In the event two or more signs share a single structure, i.e., directory signs, or signs on v-shaped structures, each sign or panel shall be considered separately for square footage purposes, provided that the

combined area of such signs cannot exceed the total square footage allowed on a single sign.

Height (of a sign). The vertical distance between the finished grade before the sign or grade of the adjacent street curb, whichever is greater, measured to the highest point of the sign.

Human sign. A sign held by or attached to a human for the purpose of advertising or providing information about a business, commodity, service, product, or other commercial activity. A person dressed in a costume for the purpose of advertising or providing information about a business, commodity, service, product, or other commercial activity shall constitute a human sign. Human signs do not include T-shirts, hats, or other similar clothing.

Incidental sign. A small sign, emblem, or decal informing the public of goods, facilities, or services available on the premises (e.g. a credit card sign or a sign indicating hours of business).

Inflatable sign. Any balloon or other device which is inflated by air or other gas and displayed outdoors. Inflatable structures primarily designed for recreational use shall not be considered to be a sign as, for example: slides, swimming pools or space walks.

Information signs. Includes bulletin boards, changeable copy directories, or signs relating solely to publicly owned institutions (city, county, state, school district) intended for use by the institution on which the sign is located.

Intersection. A place where two roads meet or form a junction. For purposes of this ordinance, sign setback distance is measured from the intersections of the curblines of two streets.

Kiosk sign or kiosk. A free-standing sign structure located in or adjacent to public right-of-way authorized by written agreement approved by the City Council that features a City of Glen Rose identification panel at the top of each structure, and displays directional information to new homes, independent school district facilities, and municipal or community events or facilities.

Marquee. A permanent roof-like structure or awning or rigid materials attached from, supported by, and extending from the facade of a building, including a false "mansard roof."

Memorial signs or tablets. Includes freestanding historical markers in accordance with state historical standards, and/or cornerstones with names and dates of construction of a building when cut into a building surface or inlaid upon it to become part of the building.

Menu boards. Freestanding or wall signs used for the purpose of informing patrons of food, which may be purchased on the premises.

Model homes sign. A temporary real estate sign placed in front of a group of model homes that is removed from the premises upon sale of the last model.

Multifamily. Locations that contain three (3) or more attached units designed for residential use including town homes and condominiums.

Multitenant center sign. A sign advertising two or more retail, wholesale, business, industrial, or professional uses (not necessarily under single ownership) utilizing common facilities including off-street parking, access, or landscaping.

Multitenant center identification sign. The portion of the sign that identifies the general name of the center or development as a whole. The sign shall include only the name and address of the development.

Nameplates. Nonelectrical, on-premises signs that communicate only the name of the occupant of the address of the premises.

Nonconforming sign. A sign that was lawfully installed at its current location prior to the adoption or amendment of this ordinance, but that does not comply with the present requirements of this ordinance.

Off-premises sign. A sign referring to goods, products or services provided at a location other than that which the sign occupies.

On-premises sign. A sign identifying or advertising the business, person, activity, goods, products, or services located on the site where the sign is installed, or that directs persons to a location on that site.

Parapet. The extension of a false front or wall above a roofline.

Point-of-sale sign. A sign advertising a retail item accompanying its display (e.g., an advertisement on a product dispenser).

Political sign. A sign advertising a political candidate or party for elective office or that advertises primarily a political message.

Portable signs. Signs not permanently attached to the ground or other permanent structure, or a sign designed to be transported by wheels including, but not limited to signs which are mounted on skids, trailers, wheels; signs converted to A- or A-frames; menu and sandwich board signs; balloons used as signs; umbrellas used for advertising.

Primary beneficiary. Any person who benefits from the installation, placement, construction, or alteration of a sign, including the owner or tenant of the property upon which the sign is located and the owner or operator of the business, product, service, or activity that is the subject of the sign.

Private traffic-control signs. Small traffic directional signs indicating interior circulation of parking areas on site, warn of obstacles or overhead clearance, or designate permissible parking.

Projecting signs. A sign used to identify the name of a business, profession, service, product or activity conducted, sold or offered on the premises where the sign is located by providing an advertising message that is perpendicular to the wall of the building to which it is attached.

Pylon signs. Freestanding signs that are supported by a structure extending from and permanently attached to the ground by a foundation or footing, with a clearance between the ground and the sign face. Pylon signs are not considered monument signs.

Real estate signs. Temporary signs advertising the real estate upon which the sign is located as being for rent, lease, or sale.

Residential. Locations where the principal use of the property is for one and two-family dwelling units.

Roof sign. Any sign installed over or on the roof of a building.

Sign. Any surface, display, design, light device, painting, drawing, message, plaque, poster, billboard or other device visible from the public right-of-way on which letters, illustrations, designs, figures, or symbols are painted, printed, stamped, raised, projected, outlined or attached in any manner whatsoever that are intended or used to advertise, inform, or attract the attention of persons both on and not on that premise, excluding those lights and landscape features which display words or symbols as holiday decorations. The term "sign" also includes the supporting structure of the sign.

Sign area. Includes all lettering, wording, logos, design, symbols, framing, roofing, and cabinets, or modules, calculated according to the provisions established in this ordinance.

Sign panel. An individual sign placard displaying directional information on a sign kiosk.

Sight triangle. The area of vehicle visibility at all street intersections, which shall be clear of all obstructions that may present a hazard to traffic. The visual triangle for a street shall be described as a 45-degree triangle where the right angle sides measure

at the very minimum twenty-five (25) feet. The visibility triangle shall be measured from a point at which the projected curb lines intersect.

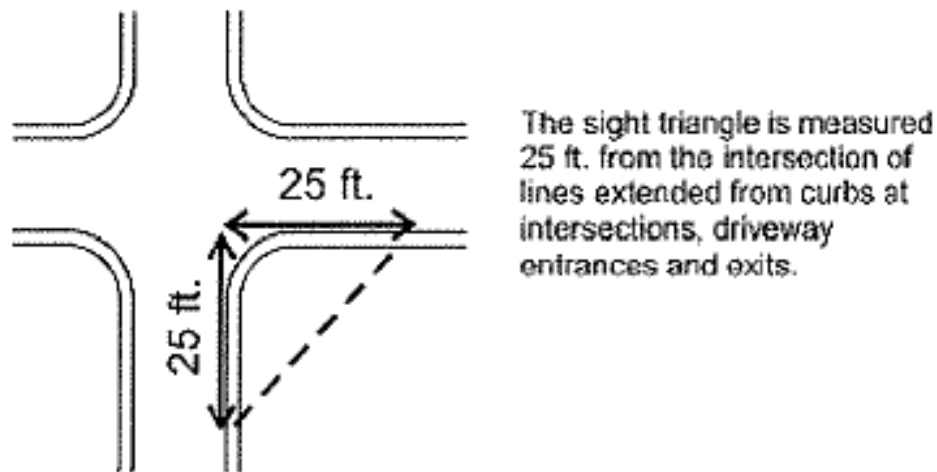

Subdivision. For purposes of this ordinance, the subdivision in its entirety, not a phase, section, village, unit, or product line.

Subdivision development entrance signs. Defined as:

- (1) Primary entrance signs;
- (2) Secondary entrance signs; and
- (3) Tertiary entrance signs;

and are used to define various entries of the subdivision.

Temporary sign. Any sign that is used temporarily and is not permanently mounted (i.e. on stakes or posts), and is constructed of cardboard, foam board, cloth, canvas, fabric, plastic, plywood, or similar lightweight material.

Temporary wall signs. An on-premises wall sign of a nonpermanent nature advertising a special event, sale, product, or service.

Wall sign. A sign attached to the facade of a building or a canopy. Wall signs include signs on or affixed to walls, windows, awnings, or other parts of the exterior of a building or canopy.

Window or door surface signs. Signs installed on or in a window or door.

Work of art. Sculpture, fountain, mural or similar object is not considered as a sign.

(a) All land within the city and its extraterritorial jurisdiction (ETJ) is subject to compliance with this chapter.

(b) The sections, provisions, and regulations set forth in this ordinance shall apply to the control, use, installation, regulation, licensing and permitting of signs within the city and its ETJ.

Permit required.

(a) *Permit required.* It shall be unlawful for any person to erect, construct, enlarge, move or convert any sign within the city or its extraterritorial jurisdiction (ETJ) without first obtaining a sign permit from and paying a permit fee unless specifically provided otherwise in this chapter. A change of business requires a new sign permit.

(b) *Compliance required.* No person may install a sign or structurally alter an existing sign except in conformity with this ordinance and other applicable federal, state, and local regulations, including, but not limited to, the building code, electrical code, and other applicable ordinances of the city. In the event of a conflict between this chapter and other laws, the most restrictive standards applies.

(c) *Permit not required.* Permits shall not be required for the following signs, provided, however, that such signs shall otherwise comply with all applicable sections of this chapter:

(1) On-site real estate "for sale" signs not exceeding eight square feet; provided that a permit is required for a model home sign and future development signs.

(2) Political signs located on private property with the consent of the property owner that do not exceed 36 square feet in area, are not more than eight feet in height, are not illuminated, and do not have any moving elements.

(3) Government signs, including traffic signs, private traffic-control signs, regulation address numerals, and memorial signs.

(4) Construction trade signs.

(5) No sign permit is required for a change of copy on any sign, or for the repainting, cleaning and other normal maintenance or repair of a sign or sign structure for which a permit has previously been issued, so long as the sign or sign structure is not modified.

(d) *Primary beneficiary.* The primary beneficiary of any sign installed, moved, structurally altered, structurally repaired, maintained, or used in violation of this ordinance shall be deemed responsible for the violation of this chapter.

(e) *Building official authority.* The building official shall enforce and implement the terms of this chapter, including without limitation:

- (1) Issuing permits and collecting the fees required by this chapter;
- (2) Conducting appropriate inspections to insure compliance with this chapter;
- (3) Instituting legal proceedings, including suits for injunctive relief when necessary, to insure compliance with this chapter; and
- (4) Investigating complaints of alleged violations of this chapter.

(Ord. No. 576, § 2(Attach., § 6), 7-7-2009)

Application for permit.

(a) An application for a sign permit must be accompanied by the permit fee and shall include such information as is necessary to assure compliance with all appropriate laws and regulations of the city, including:

- (1) The name and address of the owner of the sign.
- (2) The name and address of the owner, and if different from the owner, the person in possession of the premises where the sign is located or to be located.
- (3) Clear and legible drawings with description definitely showing location of the sign which is the subject of the permit and all existing signs whose construction requires permits, when such signs are on the same premises.
- (4) Scale drawings showing the site plan location, dimensions, construction supports, sizes, foundation, electrical wiring, and components, materials of the sign and method of attachment and character of structure members to which attachment is to be made. The design, quality, materials and loading shall conform to the requirements of the building code. Projection, wall and temporary signs not over six square feet in area, constructed of metal or other noncombustible material, attached securely to a building or structure and not projecting more than 18 inches beyond the building wall, structure, building line or property line, shall not require an engineer certification as to its soundness. Wind pressure and dead loads shall be shown where deemed appropriate, and the building official may require structural drawings designed and sealed by a civil engineer registered by the State of Texas when it cannot otherwise be determined that the sign will be structurally sound. If building official, engineering data certified by a licensed structural engineer shall be supplied on any submitted plans.

(5) Any electrical permit required and issued for said sign.

(6) For free-standing signs, documentation demonstrating that the applicant holds general liability insurance in the amount of one million dollars. No license or permit for the installation, erection and maintenance of a freestanding sign shall be issued to any person, firm or corporation until such person, firm or corporation has filed with the building official a certificate of Insurance verifying general liability insurance in the amount of \$1 million.

(7) A surety bond in the sum of \$5,000.00 for the installation and erection of the sign payable to the city and providing for the indemnification of the city and any and all damages or liability which may accrue against the city for a period of one (1) year after installation, erection, demolition, repair, removal, or defects in or collapse of any sign.

(8) The permit fee.

(b) Fees for sign permits shall be as specified in _____, and calculations of the square footage shall include decorative trim and borders, but exclude supports, except when otherwise specified in this chapter.

(c) Expiration of sign permits:

(1) A sign permit shall expire and become void unless a request for final inspection of the sign is made no later than 180 days after the date the permit is issued.

(2) A single extension 90-day extension of the permit may be granted by the building official if requested before the expiration of the permit. Final inspection must be requested before the end of the extension period or the permit becomes void.

Calculation of sign area.

(a) *Sign area measurement.* Sign area for all sign types is measured as follows:

(1) Sign copy mounted, affixed, or painted on a background panel or area distinctively painted, textured, or constructed as a background for the sign copy, is measured as that area contained within the sum of the smallest rectangle(s) that will enclose both the sign copy and the background.

(2) Sign copy mounted as individual letters or graphics against a wall, fascia, mansard, or parapet of a building or surface of another structure that has not been painted, textured, or otherwise altered to provide a distinctive background for the sign

copy, is measured as a sum of the smallest rectangle(s) that will enclose each word and each graphic in the total sign.

(3) Sign copy mounted, affixed, or painted on an illuminated surface or illuminated element of a building or structure, is measured as the entire illuminated surface or illuminated element which contains sign copy. Such elements may include, but are not limited to lit canopy fascia signs, cabinet signs, and/or interior lit awnings. Support structures and frames of a freestanding sign shall count toward the sign area.

(4) Multiface signs are measured as follows:

a. *Two (2) face signs.* If the interior angle between the two sign faces is 30 degrees or less, the sign area is of one sign face only. If the angle between the two sign faces is greater than 30 degrees, the sign area is the sum of the areas of the two sign faces.

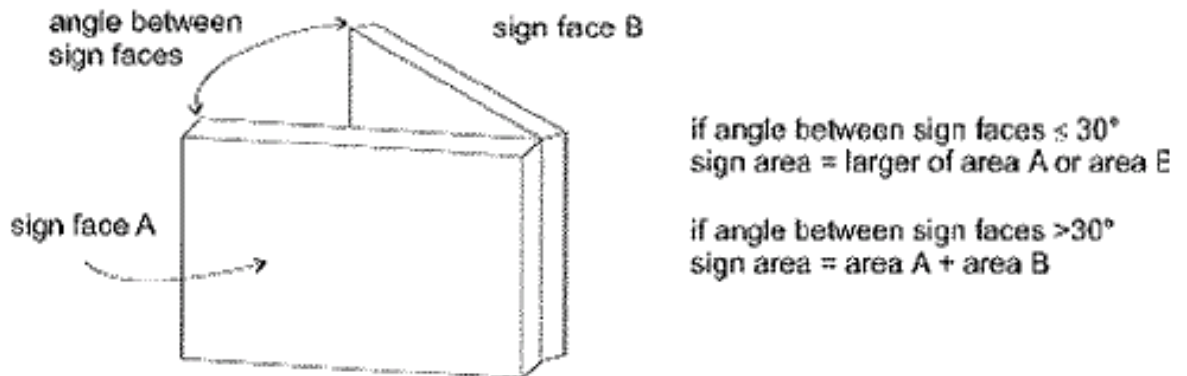

b. Three (3) or four (4) face signs. The sign area is 50 percent of the sum of the areas of all sign faces.

(5) Spherical, free-form, sculptural, or other nonplanar sign area is 50 percent of the sum of the areas using only the four vertical sides of the smallest four-sided polyhedron that will encompass the sign structure. Signs with greater than four faces are prohibited.

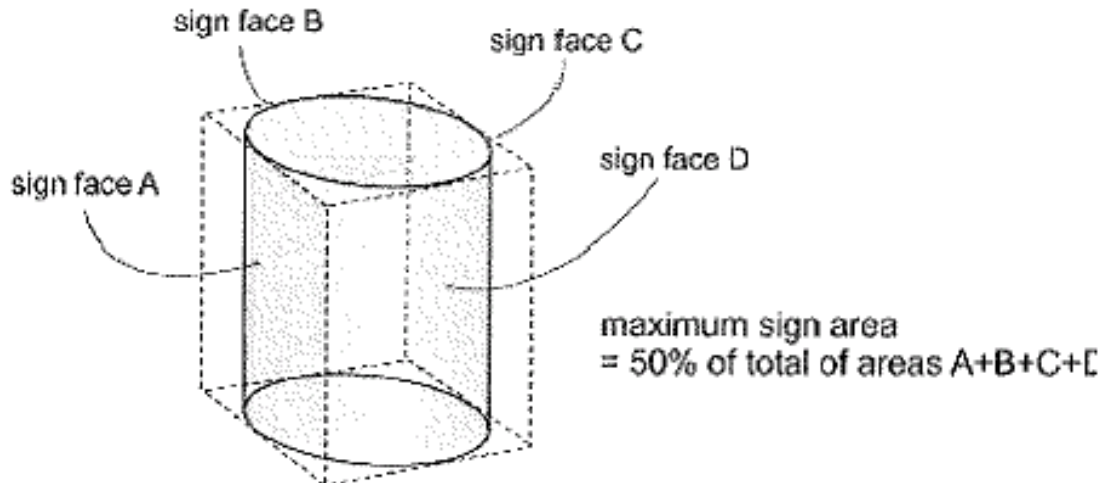

(6) Freestanding sign area is the entire advertising area of a sign, including framing, trim or molding and the supporting frame for monument signs and including the air space between the supporting structures for freestanding signs.

(b) *Sign height measurement.* Sign height is measured as follows:

(1) *Freestanding signs.* The height of a freestanding sign shall be computed as the distance from the base of the sign at finished grade to the top of the highest attached component of the sign. The height of any monument sign base or other structure erected to support or adorn the sign is measured as part of the sign height. If a sign is located on a mound, berm, or other raised area for the sole purpose of increasing the height of the sign, the height of the mound, berm, or other raised area shall be included in the height of the sign.

(2) *Building mounted signs.* The height of wall, fascia, mansard, parapet or other building mounted signs is the vertical distance measured from the base of the wall on which the sign is located to the top of the sign or sign structure.

Prohibited signs.

The following signs are prohibited from installation, construction, repair, alteration, location or relocation within the city, except as otherwise specifically permitted in this chapter or by agreement approved by the city council only during the term of the agreement:

(1) Signs with flashing lights or revolving beacon lights. For purposes of this chapter, an electronically controlled changeable-copy sign is not considered a flashing sign unless it directly falls under the definition of "flashing" as defined in this chapter.

(2) Billboards.

(3) Off-premises signs, except for kiosks and any other sign specifically authorized in this ordinance that are compliant with this ordinance.

(4) Portable signs.



(5) Temporary signs except as specified _____

(6) Signs placed on a vehicle or trailer that is parked or located for the primary purpose of displaying a sign shall be permitted.

(7) Roof signs.

(8) Signs painted on fences or roofs.

(9) Pylon signs, except as specifically provided for in _____

(10) Inflatable signs larger than eight feet in any dimension.

(11) Light emitting diode (LED) displays or signs, with the limited exception of those signs that comply with subsections _____. Such signs, when authorized, shall comply fully with the requirements of this chapter. Electronic message signs are allowed only as part of the monument sign and can have a display size no larger than 12 inches by 72 inches, except as provided otherwise in subsections _____. Messages shall be programmed to remain static for a period of not less than 60 seconds. Messages shall not be programmed to flash.

(12) Signs with a surface area that exceeds the lesser of (a) the maximum size established for the category or definition that applies to the sign or 160 square feet; or (b) the maximum height established for the category or definition that applies to the sign or 12 feet.

Signs exempt from these regulations.

The following types of signs shall be exempt from the permitting provisions of this ordinance. However, regulations regarding sign location in a public right-of-way or public access easement shall apply. It is further specifically provided that the building

official may, based upon the size, materials used in construction and other relevant factors, require the owner of any sign to show evidence of structural soundness and compliance with the safety requirements of this chapter.

(1) Any sign erected by or under the authority of the city on property owned by, leased by, or under the control of the city.

(2) Street identification signs, public notices, and warning signs installed by any city, county, state or federal agency.

(3) Historical markers placed by a city, county, state or national historical preservation organization.

(4) Official vehicle inspection station signs, holiday lights and decorations, or works of art.

(5) Signs located on-premises or inside a building and which are not displayed so as to be legible from a public street, including, but not limited to, such signs as credit card decals, hours of operation signs, emergency contact information, and barber poles.

(6) On-site traffic control signs on commercial properties, such as stop, yield, and similar traffic control signs containing no commercial message.

(7) "No parking" or "towing" signs authorized by city ordinance.

(8) "No dumping allowed" signs posted to deter illegal dumping not exceeding two square feet.

(9) Underground utility warning signs not exceeding one square foot in size and similar safety signs.

(11) Security Warning, neighborhood watch or crime watch signs under two square feet.

(12) Flags, emblems and insignia of any governmental body, including the official flag of a nation or of a state is not a sign subject to this chapter. Notwithstanding the preceding sentence, a national or state flag shall not be installed, maintained, or used in a manner that would make that flag a hazardous sign if it were a commercial flag.

(13) Corporate flags displayed on a freestanding pole, which do not exceed 35 feet in height. The flag shall not exceed 32 square feet in area. The flagpole shall be setback a minimum of 20 feet from the front property line and eight feet from the side property line.

(14) Hand held signs or signs, symbols or displays on persons or animals, except for signs that qualify as human signs.

(15) Signs located on mail boxes, newspaper vending machines and curbside residential newspaper holders which identify the owner and address of the premises or the name of the newspaper sold or subscribed to; provided that such devices are not placed so as to interfere with the safe movement of pedestrians or vehicular traffic.

(16) Signs located on outdoor machines, devices, or equipment which display the trademark, trade name, manufacturer, cost of operating or service instructions or similar information, but do not advertise the business where located. This exemption includes, but is not limited to signs on coin-operated vending machines, fuel dispensing pumps, telephone facilities, automatic teller machines, automatic vacuum cleaners, amusement rides and similar machines, devices or equipment.

Sign categories.

For purposes of this chapter, all property within the city's sign ordinance jurisdiction is classified into a sign category. Those properties within the city's limits are classified based upon their zoning district classification. Those properties located within the ETJ shall be classified into a sign category by the building official based upon the existing or proposed use and the zoning district most closely associated with that use. Classification into a sign category is for the purposes of signage only and does not establish vested use rights towards the assignment of zoning should the property be annexed into the city limits. In overlapping areas, the most restrictive sign regulations will apply:

(1) Single-family residential sign category includes any residential site area, manufactured housing, or any single-family townhouse (R1, R2, R2M, R3, R4 MH) zoning districts or equivalent land use in the ETJ. Nonresidential uses permitted in the identified residential districts shall be included in the commercial sign category.

(2) Multifamily residential sign category includes any site in a multifamily (R2, R2M, R3, R4, MH) zoning districts or equivalent use in the ETJ. Nonresidential uses permitted in the identified residential districts shall be included in the commercial sign category.

(3) Commercial sign category includes any site in general business (B2), restricted business (B1), industrial (I), equivalent use in the ETJ and the permitted nonresidential uses identified in the city's residential and multifamily zoning districts.

(4) Central business district (B3) sign category includes any site that is located within the boundaries of the central business district zoning district.

General provisions.

(a) *Uniform signs in multi-tenant/multi-business developments.* Wall signs displayed by two or more businesses using common parking facilities shall be uniform in construction (i.e. cabinets, channel letters, plaques) and lighting (i.e. direct, indirect).

(b) *Street address.* All freestanding signs, either berm or monument signs, shall include the street address. The street address shall not be included in the calculation of the sign area, except in such case that the street address is also the name of the center, business, or development, or in such case that the street address exceeds six square feet in size.

(c) *Setback.* A minimum setback of at least five feet from any property line is required for all signs. A sign installed in compliance with this ordinance is not required to meet building setback requirements established in a separate city ordinance; however, no sign or sign support, other than a wall sign, may be installed less than 10 feet from the public right-of-way unless it is:

(1) Less 30 inches in height above street pavement grade;

(2) Has a clearance of more than nine feet above pavement grade, provided that the sign shall have a clearance of more than 10 feet when located over a driveway;

(3) Does not extend into or over the public right-of-way unless specifically authorized under this chapter.

(d) *Visibility.* Signs shall not be constructed or installed in a manner that would interfere with visibility, create a traffic hazard, or be confused with any traffic control sign or signal.

(e) *Structural integrity.* Any sign as defined in this ordinance, shall be designed and constructed to withstand wind pressures and receive dead loads as required in the building code adopted by the city. Any sign, other than a wall sign, shall be designed, installed, and maintained so that it will withstand a horizontal pressure of 30 pounds per square foot of exposed surface.

(f) *Maximum height.* No sign shall exceed the maximum height provided for in this chapter. In determining the maximum height of a sign, no sign shall be located on a mound where the surrounding grade has been altered by more than 18 inches for purposes of artificially increasing the overall height of a sign above that allowed by the height regulations in this chapter.

(g) *Historic district.* Signs on premises within a historic district designated by the city shall be subject to the issuance of a certificate of appropriateness by the state or local historic preservation commission.

(h) *Public utility facilities.* New signs and signs being structurally altered shall maintain clearance from public utility facilities, shall not substantially interfere with drainage, and shall not be located in a utility or drainage easement. The minimum clearance from electrical lines shall be as follows: for service lines, except those serving a sign, 5½ feet horizontal and six feet vertical clearance; for distribution lines, 7½ feet horizontal and eight feet vertical clearance.

(i) *Parking, driveways, sidewalks.* Only signs required in the interest of public safety may occupy a required off-street parking or loading space or obstruct any driveway or sidewalk, except as specifically authorized herein.

(j) *Public property.*

(1) No sign shall be located on or project over public property or a street right-of-way except governmental signs, bench signs, and temporary banner signs that comply with this chapter, except where a provision in this ordinance allows such location, or with the approval by the city council of a license agreement. No portion of a freestanding sign shall be permitted to extend into the public right-of-way.

(2) No person shall, either directly or indirectly, cause or authorize a sign to be installed, used, or maintained on any utility pole, traffic signal pole, traffic signal controller box, tree, public bench, street light, or any other structure located on or over any public property or public right-of-way, located within the city's planning jurisdiction, except as authorized by this chapter.

Illumination.

(a) *Lighting.* Sign lighting shall be installed to protect the driver of a vehicle from dangerous glare and to maintain visual clearance of all official traffic signs, signals and devices.

(b) *Glare.* Signs shall be designed, located, shielded, and directed to prevent the casting of glare or direct light from artificial illumination, upon adjacent public right-of-way and surrounding property.

(c) *Bare bulb illumination.* Bare bulb illumination is prohibited.

(d) *Brightness limitations.* The lighting intensity of a sign, whether resulting from internal illumination or external illumination, shall not exceed 75 foot candles when

measured with a standard light meter perpendicular to the face of the sign from a distance equal to the most narrow dimension of the sign.

(e) *Electrical permit.* All signs in which electrical wiring and connections are to be used shall be subject to the applicable provisions of the city's electrical codes.

(f) *Central business sign category.* In the central business sign category, neon or phosphorescent lighting shall not exceed 10 percent of the total signage allowed and may only be located in a window.

- **Sign regulations relating to single-family residential sign category.**

(a) *General.* No sign other than a temporary event directional sign (such as a garage sale sign, event sign, or a real estate sign) or a political sign that comply with _____ shall be erected on property used for single-family or duplex dwellings.

(c) *Model home signs.* Model home signs are limited to a 32 square foot sign face, a height of eight feet, and to one sign for each cluster of model homes. A nameplate sign that identifies the individual product name is exempt under this subsection if it does not exceed three square feet in sign area. Signs shall be placed by permit only, and no fee shall be required.

(d) *Subdivision development entrance sign.* A subdivision development entrance sign is a sign authorized for each major project entry into a legal recorded, multi-lot, multi-sectioned, master-planned subdivision, and contains only the name of the subdivision with no other information. Subdivision entrance signs must be berm or monument signs constructed of stone, brick or other maintenance free material. The design and construction must be compatible with surrounding development. Signage may appear on both sides of the entrance roadway within the recorded or master-planned subdivision and will be soldered as one sign. The maximum allowable sign face size limitations will apply separately to each side of the street, where applicable. Lighting shall be ground lights or lights attached to the top of the sign focused downward directly on the sign. There are three types of subdivision development entrance signs: primary, secondary, and tertiary.

(1) Primary entrance sign is located at the primary entrance into the subdivision. Only one primary entrance sign is permitted for the subdivision, except that a maximum of two primary entrance signs shall be permitted if two entrances to the subdivision are located on two different major arterial roadways, as designated in the city roadway plan. In such case one primary entrance sign may be placed on each of the major arterial roadways.

a. The maximum sign area of the sign is 32 square feet for subdivisions containing 100 lots or less. For every 100 lots in the subdivision in addition to the first one hundred, the size can increase an additional ten square feet to a maximum size of 64 square feet of total sign face area. If the sign face is incorporated into landscape features, a wall, or architectural feature, the size of the sign face is determined by the area of the smallest rectangle within which the face of the sign can be enclosed.

b. A subdivision primary entrance sign must be located within the subdivision or at an off-premises location adjacent to an arterial roadway within 150 feet of the primary entrance to the subdivision. It shall not restrict visibility at intersections. The city may enter into a license agreement to permit a subdivision identification sign to be located on the public right-of-way. The license agreement shall be in a form acceptable to the city.

(2) Secondary entrance signs are located at entrances into the subdivision other than at the primary entrance. They are to be placed at an on-premises location within the subdivision and the sign face shall be a maximum of 16 square feet in size.

(3) Tertiary entrance signs are located at the entryway into sections within the subdivision and are permitted only in subdivisions that exceed 50 acres. they are used to identify various sections that are 25 acres or greater in size in order to enhance direction within the subdivision. These tertiary signs shall be comprised entirely of stone or masonry, with engraved lettering set within the stone. They shall be berm signs only and shall be limited to a total monument size of ten square feet. The developer shall represent in writing to the city its plan for perpetual maintenance of such signs by the homeowner's association or similar entity before a permit will be issued for such signs.

(e) *LED signs.* No LED displays, signs, or message boards are permitted in the single-family residential category, unless the sign is a pylon sign located on a middle school or high school campus and the sign complies with subsection ____

Sign regulations relating to multifamily residential sign category.

(a) Signs in multifamily locations shall be limited to signs allowed in this section and in all applicable restrictions of this ordinance as well as other requirements of the code, and any other applicable law.

(b) Except as provided in this subsection, a single freestanding sign is permitted only as berm or monument signs on the same lot as the development to identify the development and its entrance. Signs must be constructed of stone, brick or other maintenance free material.

(1) Lighting shall be ground lights or lights attached to the bottom of the sign focused upward directly on the sign.

(2) The maximum size of the sign shall be nine-hundredths (0.09) square feet per linear foot of frontage, up to a maximum size of 24 square feet. A minimum size of 12 square feet is allowed for a berm sign.

(3) The maximum height of the sign shall be eight feet.

(4) In the event the development has a second entrance from a public street, a second entrance sign may be constructed, at one-half the size of the one main entry sign.

(c) Wall signs are permitted at a size to be calculated as 0.5 square feet per linear foot of frontage, not to exceed a total of 35 square feet.

(d) Window or door surface signs are allowed. The total sign area of all window and door signs shall be included in calculating the maximum wall sign area authorized at a particular location.

(e) *LED signs.* No LED displays, signs, or message boards are permitted in the multifamily residential sign category, unless the sign is a pylon sign located on a middle school or high school campus and the sign complies with _____

- **Sign regulations relating to commercial not located on US Hwy 67 sign category.**

(a) *Applicability.* The regulations for signs described in this section shall apply to the commercial sign category and to all businesses and civic or religious institutions, excluding home occupations and multifamily developments, located on property that does not front on US Hwy 67

(b) *General.*

(1) Except as otherwise provided in this section, a single freestanding sign is permitted on the same lot as the development to identify the development and its entrance. In the event the development has a second entrance from a public street, a second entrance sign may be constructed.

(2) Notwithstanding any language to the contrary, a pad site or satellite tract within a unified development, whether or not legally subdivided (such as a site for a freestanding service station or restaurant set apart from the unified development) may be considered a separate lot for purposes of this section, and one freestanding sign shall be permitted on each such site.

(c) *Materials.* Signs must be constructed of metal, stone, brick or other maintenance free material.

(d) *Lighting.* Shall meet all dark sky recommendations

(e) *Dimensions for monument signs and berm signs.*

(1) Monument Signs shall not exceed nine-hundredths (0.09) square feet per linear foot of frontage, up to 24 square feet for single-user signs, or for the center identification portion of a multitenant center identification sign.

(2) A minimum size of 12 square feet is allowed for a berm sign.

(3) For a multitenant center sign for a business not located along a state highway, each tenant that has a business in the center shall also be permitted a maximum of four square feet of sign area on a multitenant center sign in the development. This area is separate from the calculation of the size of the multitenant center identification sign.

(4) For a multitenant center sign for a business located along a state highway, each tenant that has a business in the center shall also be permitted a maximum of eight square feet of sign area on a multitenant center sign in the development. This area is separate from the calculation of the size of the multitenant center identification sign.

(5) The maximum height of the monument sign shall be ____ feet. (6ft -?)

(f) *Additional regulations for freestanding berm signs.*

(1) For businesses, civic, or religious institutions, two signs are authorized on a lot with total frontage of more than 400 feet abutting a roadway, however, the second sign shall be constructed at half the size of the initial sign.

(2) A lot used together with one or more contiguous lots for a single use of unified development (for example, a shopping center), including any lots used for off-street parking, shall be considered a single lot for purposes of these regulations.

(g) *Wall signs.*

(1) Wall signs for commercial entities not located along a state highway are permitted at a size to be calculated as ten percent of the building facade of the first 15 feet of building height. The calculation applies to each exterior wall separately.

(2) Wall signs for commercial entities along a state highway are permitted at a size to be calculated as twenty percent of the building facade of the first 15 feet of building height. The calculation applies to each exterior wall separately.

(h) *Menu board signs.* Menu board signs can be freestanding or wall signs with a maximum sign area of 20 square feet and a maximum height of eight feet above grade. A menu board shall be landscaped and substantially screened from the public right-of-way. No more than two menu boards are authorized for each drive-through lane at a business.

(i) *Incidental signs.* The total sign area of all incidental signs per premises shall not exceed four square feet.

(j) *Gas price display.* For establishments that have service stations selling gasoline and/or diesel at the pump, an area can be included for changeable copy displaying gas prices. The area provided for each grade of fuel shall not exceed four square feet in size, and shall include the price and grade.

(k) *Signs located on middle school and high school campuses.*

(1) A maximum of one pylon sign may be permitted on each middle school or high school campus.

(2) The maximum area of a pylon sign is 60 square feet. The maximum height is 16 feet.

(3) Electronic message signs are allowed only as part of the pylon sign and can have a display size no larger than ten feet by three feet.

(l) *LED signs.* No LED displays or LED signs are permitted under this section, unless the sign is a pylon sign permitted under subsection (k) or is a monument message board sign.

(m) [*Special exceptions for certain signs.*] Notwithstanding the provisions, limitations, prohibitions, and other requirements of this chapter, the city council may authorize, by four affirmative votes, a special exception permit in compliance with this sub-part for the establishment of unique, remarkable, wayfinding, iconic, or destination signage structures of regional interest for nonresidential projects. The city council may impose appropriate conditions and safeguards, including but not limited to a specified period of time for the display of the signage, to protect the corridor viewshed, and to conserve and protect property and property values in the neighborhood.

(1) Public hearing and notice of the proposed zoning change.

a. Not less than ten days prior to the date of the public hearing to be held by the mayor and city council on each request for special exception,

written notice of the public hearing and the request proposed shall be given by U.S. mail to the owner of each lot, tract or parcel of land within 200 feet of the lot, tract or parcel being considered for the special exception. Such notices shall be mailed by first class mail addressed to the persons or firms to whom the properties are assessed on the city tax rolls.

b. Posted notice. A minimum of one sign shall be placed on each street frontage, public or private, with not more than 400 feet between any two signs along the same frontage. Property with multiple street frontages shall have the requisite sign on each street. Signs shall be placed in a visible, unobstructed location near the property line.

c. The notification signs shall be left in place until final action is taken on the request, unless the case is formally withdrawn by the applicant prior to a final decision. It shall be the responsibility of the applicant to periodically check sign locations to verify that signs remain in place and have not been vandalized or removed. The applicant shall immediately notify the responsible official of any missing or defective signs.

d. Notice of the public hearing to be held by the city council shall be given by publishing such notice at least once in a newspaper of general circulation in the city, at least 15 days prior to the date set for public hearing.

e. If the special exception is proposed by the city council or the planning and zoning commission, notice of the proposed special exception shall be made by the City Administrator mailing notification by first class mail to the person or firm to whom the property is assessed on the city tax rolls, and to all persons or firms to whom property within 200 feet of the proposed special exception is assessed on the city tax rolls.

f. The required notice for a public hearing having been given for the special exception, the city council may, as applicable, continue such matter to subsequent public meetings for final determination.

(2) Appropriate conditions and safeguards for the approval of special exceptions described in this sub-part include:

a. Type of signage (wall-mounted or freestanding).

b. Materials.

c. Lighting: Signage must be made to conform with the city's lighting ordinance found in _____

d. Overall size/dimensions.

- e. Sign structure location.
- f. Architectural/aesthetic theme.
- g. Location along major thoroughfares and corridor visibility.
- h. Mutually beneficial value to the city's interest, the community at-large, and the on-site establishment
- i. Duration of display: The application for special exception may be approved subject to an expiration as set by the council at the time of determination.

Sign regulations relating to the central business district sign category.

- (a) The design and construction must be compatible with surrounding development. Signage may appear on both sides of the sign and shall be soldered as one sign.
- (b) Lighting shall be Internal lighting, ground lights that meet dark sky requirements or lights attached to the top of the sign focused downward directly on the sign
- (c) Signs shall have a minimum set back of five feet from any property line.
- (d) No LED displays, signs, or message boards are permitted under this section.

Attached sign regulations.

(a) *Awning signs.* The purpose of an awning sign is to provide an advertising message on the face of an awning. Awning signs shall only be allowed within commercial districts, industrial districts, the central business district.

(1) An awning may extend across the entire width of a building or tenant space. An awning may extend above the apparent roof line of the building, provided the awning extends across 75 percent of the entire width of the building facade to which it is attached. An awning shall not exceed six feet in height.

(2) The sign area on an awning shall not exceed 20 percent of the area of the awning and shall extend for no more than 50 percent of the length of the awning. A permit shall be required for an awning sign. Awning signs may be illuminated.



(b) *Canopy signs.* A canopy sign shall be no greater in size than 20 percent of the face of the canopy of which it is a part or to which it is attached and shall not extend beyond the face of the canopy either vertically or horizontally. An illuminated strip may be incorporated into the canopy. Canopy signs shall only be allowed within commercial districts, industrial districts, and the central business district.

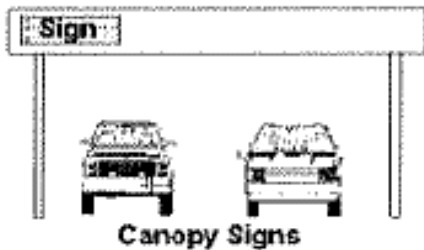

(c) *Projecting signs.* The purpose of a projecting sign is to identify the name of a business, profession, service, product or activity conducted, sold or offered on the premises where the sign is located by providing an advertising message that is perpendicular to the wall of the building to which it is attached. Projecting signs shall be allowed within commercial districts, industrial districts and within the central business district.

(1) *Number of signs:* One projecting sign shall be allowed for each single tenant building or for each tenant in a multi-occupancy structure. However, no tenant storefront shall have a projecting sign in combination with a wall sign on the same building elevation.

(2) *Maximum area:* A projecting sign shall not exceed 20 square feet. The plane of the message area shall not exceed 18 inches from the plane of the message area on the opposite side of the sign.

(3) *Horizontal projection:* A projecting sign shall not project more than four feet from any wall facing and shall not be closer than two feet from a curb line. A projecting sign shall not extend above the apparent roof line of the building.

(4) *Clearance:* Every projecting sign shall be a minimum of eight feet above the grade over a walking area or 14 feet over a vehicular maneuvering area. Projection signs shall not project over any property line or right-of-way line unless with an approved license agreement.

(5) A projecting sign may be illuminated.

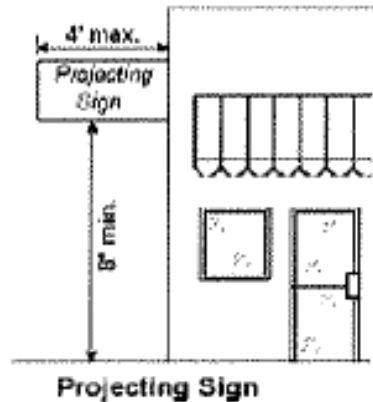

(d) *Light mounted banner signs.* Light mounted banner signs shall only be permitted in the central business district for the advertising of permitted community events, seasonal and historic themes, or other such civic purposes; on collector level and higher classification within a residential subdivision; within master planned commercial subdivision. Such banners are limited to subdivision identification, or seasonal decorations and works of art by local artists. Such banners must be approved by the appropriate electric utility company in addition to receiving a permit from the City Administrator's office. No permit shall be approved for a period exceeding 30 calendar days. Light mounted banner signs shall comply with the following regulations:

- (1) Banners shall be limited to not more than one banner on any light pole.
- (2) Banners shall be limited to no more than two feet by six feet in exterior dimension and 12 square feet in area per banner.
- (3) A minimum height of six feet as measured from adjacent grade to the bottom of the banner shall apply.
- (4) Banners shall be maintained in good repair. Should they become excessively faded, tattered or torn, they shall be replaced or removed.
- (5) Banners shall not be illuminated, except for indirect lighting associated with the main lamp of the light pole to which it is mounted.

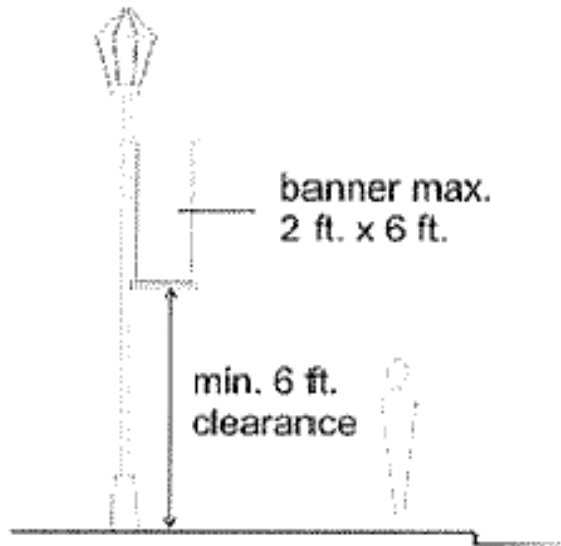

(e) *Subdivision wall signs or plaques.* Subdivision wall signs or plaques shall not exceed 30 square feet in area. Subdivision wall signs or plaques are limited to two per subdivision entryway and may be illuminated. A subdivision wall sign or plaque shall be attached to a fence or screening wall. For purposes of this regulation, the size of the graphic and sign text shall be used to measure sign size.

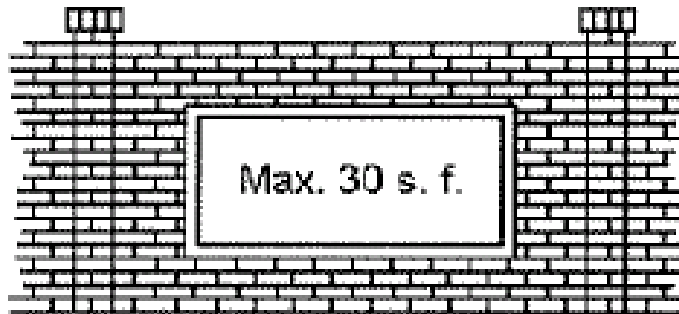

Subdivision Wall Plaque

Temporary sign regulations.

(a) *Construction trades signs.* The purpose of a construction trades sign is to denote the architect, engineer, financial institution or building trades contractor involved in a construction project. Construction trades signs shall be categorized as either commercial or residential.

(1) The maximum area, height, spacing and setbacks of a construction trades sign for commercial locations shall not exceed 64 square feet and shall not exceed ten feet in height.



(2) The maximum area, height, spacing and setbacks of a construction trades sign for residential locations shall not exceed eight square feet and shall not exceed four feet in height.



(3) Construction trades signs shall not be erected until a building permit has been submitted for building construction and shall be removed up on completion of the construction project or occupancy of the structure, whichever is applicable.

(4) No permit or fee shall be required for a construction trades sign.

(5) Signs shall not be located in the street right-of-way, shall be placed at least twenty-five (25) feet from an intersection and a minimum of ten (10) feet from the curbline.

(6) A construction trade sign shall not be illuminated.

(b) *Future development signs.* Future development signs shall be regulated as either commercial or residential.

(1) The maximum area, height, spacing and setbacks of a future development sign shall not exceed 64 square feet and shall not exceed ten feet in height.

(2) A permit shall be required for a future development sign.

(3) A future development sign shall not be illuminated.

(4) A future development sign shall be removed when the project is 90 percent complete or within three years from start of construction, whichever is less. For the purpose of this provision, a subdivision shall be deemed 90 percent complete when ninety (90%) percent of the lots within the subdivision are sold.

(5) Signs shall not be located in the street right-of-way, shall be placed at least 25 feet from an intersection and a minimum of ten (10) feet from the curbline.

(6) One sign shall be permitted per lot; except that one sign per major access to the development shall be authorized if a lot is used together with one or more contiguous lots for a single use or a unified development (for example, a shopping center).



(c) *Garage sale signs.* The purpose of a garage sale sign is to announce the sale of household possessions.

(1) Garage sale signs shall not exceed four square feet. Signs shall be allowed for a maximum of 72 consecutive hours no more than two times per calendar year.

(2) Single-family residential on-premises: One garage sale sign per street frontage shall be allowed, but only on the premises where the garage sale is being conducted and where there is an existing residential use.

(3) Neighborhood-wide garage sales: Two garage sale signs per subdivision entrance shall be allowed for a neighborhood-wide garage sale sponsored by a homeowner's association (HOA). The garage sale sign may be off premises from where the actual garage sale is conducted, but the sign shall be located on property, including a street right-of-way, that is within the limits of the homeowner's association. The HOA must be registered with the city.

(4) Signs shall be placed at least 25 feet from an intersection and a minimum of ten feet from the curbline. Signs shall not be placed anywhere in the center median of a public or private street.

(5) No permit or fee shall be required for any garage sale sign.

(d) *Real estate signs (commercial, including multifamily).* The purpose of a commercial real estate sign is to advertise the sale, rental or lease of the premises on which said sign is located.

(1) A commercial real estate sign shall not be illuminated.

(2) The maximum area and height of a commercial real estate sign shall not exceed 64 square feet and shall not exceed ten feet in height.

(3) Commercial real estate signs shall be removed within seven days following the completion of the sale, rental or lease of the premises.

(4) No more than one sign per 300 linear feet of street frontage may be placed on such property.

(5) Signs shall be placed at least twenty-five feet from an intersection and a minimum of ten feet from the curblines.

(6) No permit or permit fee shall be required for a commercial real estate sign.

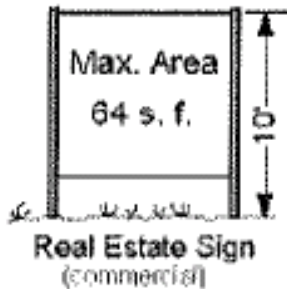

(e) *Real estate signs (residential)*. The purpose of a residential real estate sign is to advertise the sale, rental or lease of the premises on which said sign is located.

(1) A residential real estate sign shall not be illuminated.

(2) The maximum area and height of a residential real estate sign shall not exceed 12 square feet and shall not exceed six feet in height.

(3) All signs shall be removed within seven days following the completion of the sale, rental or lease of the premises.

(4) Signs shall be placed at least 25 feet from an intersection and a minimum of ten feet from the curblines.

(5) No permit or permit fee shall be required for a residential real estate sign.

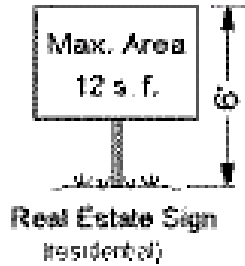

(f) *A-frame signs*. The purpose of an A-frame sign is to provide temporary advertising during business hours of a commercial occupancy.

(1) Maximum height and area shall conform to the following table:

Maximum Height and Areas of A-Frame Signs		
	Max. Area	Max. Height
Located on a sidewalk	8 s.f.	4 feet
Located in a yard	24 s.f.	8 feet

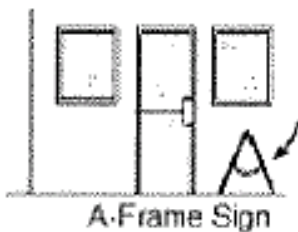

(2) Time duration: Only displayed during business hours.

(3) Placement: Only allowed on private property, but may be located on a public sidewalk, provided a width of four feet shall remain free from intrusion.

(g) *Miscellaneous temporary sign regulations*.

(1) Temporary signs advertising the opening or relocation of a business shall only be permitted for a maximum period of 30 days before and 60 days after such opening or relocation. Signs shall be placed at least 25 feet from an intersection and a minimum of ten feet from the curblin.

(2) Except as specifically provided otherwise in this chapter, banners shall not exceed 32 square feet, must be attached and parallel to a wall of the structure, and

shall only be permitted for a period not to exceed 30 calendar days and with a period of not less than 30 days between displays.

(3) Human signs shall be allowed on private property and the untraveled public rights-of-way provided that no human sign, as defined by this ordinance, shall be displayed within five feet of a vehicular traffic lane.

(4) Except as specifically provided otherwise herein, temporary signs shall not exceed four square feet in size and shall be allowed for a maximum of 14 calendar days per event. Temporary signs shall be placed at least 25 feet from an intersection and a minimum of ten feet from the curbline. Temporary signs shall not be placed anywhere in the center median of a public or private street.

(5) Open house signs do not require a permit, shall not exceed four square feet, and shall be allowed for a maximum of four hours the day of the open house. Open house signs shall be placed at least 25 feet from an intersection and a minimum of ten feet from the curbline. Open house signs shall not be placed anywhere in the center median of a public or private street.

(6) Use of temporary decorations as signs, otherwise referred to as decorative festoons, meaning tinsel, strings of ribbon, small commercial flags, or streamers may be used as temporary enhancement of signage in a commercial sign category, providing these devices have no glare, no moving parts, are maintained, and comply with all codes and policy guidelines governing their safe use. No lettering is permitted on these items. Temporary decorations may be used for a period not to exceed 30 calendar days with a period not less than 30 days between displays.

- **Flagpoles and commercial flags.**

One flagpole is allowed per development at a maximum height of 20 feet. Commercial flags are allowed in multifamily and/or commercial developments. No text or logo is permitted on such flags as such would constitute a sign. The national or state flag and the flagpoles for the express purpose of displaying the national or state flag are exempt from this section.

- **Advertising searchlight.**

(a) For purposes of this section, an "advertising searchlight" means a searchlight used to direct beams of light upward for advertising purposes.

(b) Use of an advertising searchlight at any location is authorized upon issuance of a permit by the building official.

(c) The permit shall be effective for a maximum period of five days per calendar year to any business or group.

(d) An advertising searchlight shall not be operated between the hours of 12:00 a.m. and 6:00 p.m.

Kiosk signs.

(a) Kiosk signs are intended to provide a uniform, coordinated method of providing homebuilders and developers a means of utilizing directional signs, while minimizing the negative impacts of weekend homebuilder's signs on the appearance of the city. Kiosk signs are also intended to provide service to the public on the directions to municipal facilities and parks, community events, and school district facilities.

(b) The city council may, by duly executed license agreement, grant the exclusive right to design, erect and maintain kiosk signs within the city limits and extraterritorial jurisdiction of Glen Rose.

(c) Kiosk signs shall be designed and constructed in accordance to the specifications contained in the aforementioned license agreement.

(d) Prior to erecting any kiosk sign, the licensee shall submit a sign location map to the building official for approval.

(e) Kiosk sign installation shall include break-away design features as required for traffic signs in the street right-of-way.

(f) Advertisement of price information shall be prohibited on kiosk signs.

(g) No additional or extraneous signs, pennants, flags or other devices for visual attention or other appurtenances shall be attached to kiosk signs.

(h) Kiosk signs shall not be illuminated.

(i) Individual sign panels on kiosks shall have a uniform design and color.

(j) Kiosk signs shall not interfere with the use of sidewalks, walkways, bike and hiking trails; shall not obstruct the visibility of motorists, pedestrians or traffic control signs; shall not be installed in the immediate vicinity of street intersections; and shall comply with the visibility triangle requirements contained in the Subdivision Regulations or other visibility easements provided by code or subdivision plat.

(k) Kiosk sign may be located on private property, or other state-maintained roadways, provided written permission is obtained from the property owner.

(l) In accordance to the specifications contained in the aforementioned license agreement, a percentage of the kiosk sign panels shall be reserved for the City to use as directional signage to municipal or community facilities or locations or community events.

(m) No kiosk sign shall be placed, located, or installed on city-owned property or public right-of-way without a license agreement duly approved by the city council.

Other sign regulations.

(a) *Activities and events sign.* An activities and events sign is a changeable copy directory allowed solely to public buildings, church buildings (places of worship only), and neighborhood associations, intended for use only by the entity where the sign is located. A maximum of one information sign shall be allowed for each neighborhood group, church, or public development complex, and it is not considered a freestanding sign in this article. Activities and events signs shall comply with the following criteria:

(1) The sign shall be constructed of a non-oxidizing metal (e.g. aluminum, stainless steel) cabinet set on a pole or on the ground as a monument, with a clear, acrylic panel inset and a locking door. The door of the sign shall remain locked except while the message is being posted.

(2) The maximum size of the cabinet shall be 12 square feet; and maximum height shall be five feet above grade.

(3) Only changeable letters shall be used and letters shall be no larger than four inches and no less than two inches in height.

(4) Such sign may have direct lighting that is placed inside the cabinet (portrait lighting); however, no backlighting or external direct lighting is permitted.

(5) Such sign shall be located at or near the entrance of the public building or church; for a neighborhood sign, such sign shall be located within the subdivision at a commonly traveled location, for example, near the neighborhood park or amenity center, the main mail station, or the main entrance to the neighborhood. Such a sign shall not be required to meet building setback requirements or setback requirements established in _____ provided that it does not obscure the travel path or visibility of drivers, bicyclists, or pedestrians, as determined by the planning department. Such sign shall be located on property maintained by the neighborhood association or with a written agreement between the property owner and the neighborhood association. Such sign shall not be placed closer than 150 feet from the intersection of a collector street and a major or minor arterial street, as defined in the city roadway plan. Such signs shall be maintained by the neighborhood association in a "like-new" condition at all times.

(b) *Government sign.* Government sign(s) are permitted in all categories, subject to all laws and regulations that apply.

(c) *Memorial sign.* Memorial sign(s) may be installed in accordance with state historical standards, or as building cornerstones not to exceed eight square feet.

(d) *Private traffic-control signs.* Private traffic-control signs are not allowed for single-family residential or duplex uses, but are otherwise permitted. Signs shall not exceed four square feet in size, and may contain directions and the name or logo of the same-site user.

(e) *Window signs.* Window signs may be placed so as not to obscure more than 25 percent of the visible window area. Where multiple windows exist, fronting on the single elevation, the 75 percent visibility shall be maintained for the total window area on said elevation.

Nonconforming signs.

(a) By the passage of the ordinance from which this chapter derives and its amendments, no presently illegal sign shall be deemed to have been legalized unless such sign complies with all current standards under the terms of this ordinance and all other ordinances of the city. Any sign which does not conform to all provisions of this ordinance but which existed on the effective date of this chapter and was lawfully constructed or installed shall be considered as a non-conforming sign. All non-conforming signs shall be permitted in the same manner as any other legally existing sign or proposed sign; provided that no sign that was constructed or installed in violation of any state or local law, or that was originally constructed or installed without a permit that was then required at such time, shall be or qualify as a non-conforming sign.

(b) A nonconforming sign shall be allowed to be continued and maintained at its existing location subject to the limitations of this section.

(c) No nonconforming sign may be enlarged or altered in a way which would increase its nonconformity; provided that the sign face may be changed in compliance with this chapter.

(d) A nonconforming sign shall be removed immediately if any of the following applies:

(1) The nonconforming sign is abandoned as defined in this subsection. Whenever any non-conforming sign no longer advertises a bona fide business or a business which has moved away or closed, a product sold, or service rendered, such sign shall be removed within 60 days. If the non-conforming sign is a wall sign, the wall sign shall be removed or painted over with a color that resembles or matches the rest

of the wall of the building. If the owner of, or person responsible for the sign, or if the tenant closing a business, fails to remove the abandoned sign or paint over the wall sign, the owner of the premises shall be held responsible and the work shall be done within 30 days following written notice to do so by the building official.

(2) The building official or his/her designee determines the sign to be obsolete or substandard under any applicable ordinances of the city to the extent that the sign becomes a hazard or dangerous.

(3) A nonconforming sign, or a substantial part of it, is destroyed or dismantled for any purpose other than maintenance operations or for changing the letters, symbols, or other matter on the sign.

(e) Reconstruction, repair, or replacement of a nonconforming sign shall be completed no later than 90 days following the date of the damage. For purposes of this subsection, a sign, or a substantial part of a sign, is considered destroyed if the cost of repairing the sign is more than 50 percent of the cost of installing a new sign of the same type at the same location.

Hazardous signs.

Except as otherwise provided by law or this chapter, no person may install, maintain, or use a sign that:

(1) Obstructs a fire escape, required exit, window, or door used as a means of escape.

(2) Interferes with a ventilation opening, except that a sign may cover a transom window if otherwise in compliance with the building code and fire code.

(3) Substantially obstructs the lighting of public right-of-way or other public property, or interferes with a public utility or traffic-control device.

(4) Contains or utilizes a supporting device placed on public right-of-way or other public area within the city limits and the extraterritorial jurisdiction of the city, unless the use of the public rights-of-way or other public area has been approved by the city and a right-of-way joint use agreement has been filed.

(5) Is illuminated in such a way as to create a hazard to pedestrian, bicycle, or vehicular traffic.

(6) Creates a traffic hazard for pedestrians, bicyclists, or motorists, by restricting visibility at a curb cut or adjoining public street.

(7) Has less than nine feet of clearance above street pavement grade or has less than 12 feet of clearance above a driveway, and/or is located outside the public right-of-way and within the visibility triangle at an intersection that results in impaired sight distance of users of the intersection.

(8) Violates a requirement of the electrical code.

(9) Is determined by the building inspector to be dangerous.

Abatement of sign violations and removal of unsafe signs.

(a) Any sign that is structurally unsafe or that constitutes a hazard to the health, safety, or public welfare by reason of inadequate maintenance, dilapidation, obsolescence, fire hazard, disaster damage, abandonment or other cause is hereby declared to be a public nuisance and shall be abated by demolition or removal.

(b) Should the building official or the code enforcement officer determine that any sign is not properly maintained, is unsafe or insecure or has otherwise been constructed, erected or maintained in violation of the provisions of this chapter, he shall take action as follows:

(1) Except as provided in the following paragraphs (2) and (3), the building official shall give the sign or property owner written notice to repair, remove or obtain a permit for such sign as applicable within ten days after such notice. If the sign or property owner fails to remove, repair, or obtain a permit for such sign so as to comply with all applicable standards and regulations, the building official shall cause the sign to be either removed or repaired and such cost shall be charged to and paid by the property owner. If such demolition or repair expenses are not paid by the property owner within 30 days of such billing, then such expenses shall constitute a valid lien against the property. Such notice shall also provide the sign or property owner an opportunity to bring the sign into compliance or to request a hearing before the sign control board to determine whether the sign should be repaired or removed. Such appeal must be filed in writing with the City Secretary within ten days of the notice. After consideration of all facts, the sign control board shall rule upon the appeal.

(2) The building official may cause any sign which is an immediate peril to persons or property to be removed summarily and without notice.

(3) Any sign located in public right-of-way may be immediately removed by the building official without notice to the owner.

(c) In addition to the above, the building official or the code enforcement officer may issue citations without giving prior notice of violation or pursue any other

administrative or legal remedy in order to abate any sign which is in violation of this chapter or any other law.

Repairs and maintenance.

All signs in the city and its ETJ shall be properly maintained in good and safe structural condition, shall be painted on all exterior parts, unless coated or made of rust resistant material, and shall be maintained in good condition and appearance at all times. Any owner or primary beneficiary failing to maintain, repair, or remove any such sign after due notices has been given shall upon conviction be guilty of a misdemeanor. The building official shall have the authority to order the painting, repair, or removal of a sign and accompanying landscaping which do not comply with this ordinance or the building codes or that constitutes a hazard to safety, health or public welfare by reason of inadequate maintenance, dilapidation, obsolescence or abandonment.

- **Appeals; exceptions to sign regulations.**

Penalty.

(a) Any individual, association, corporation or legal entity violating any provision of this ordinance shall be deemed guilty of a misdemeanor and, upon conviction thereof, shall be punished by the assessment of a fine not exceeding \$2,000.00 and a separate offense shall be deemed committed upon each day during or on which a violation occurs or continues.

(b) The primary beneficiary of any sign installed in violation of this section shall be presumed to have authorized or caused, either directly or indirectly, the installation, use, or maintenance of the sign in violation of this chapter.

(c) Whenever any construction, installation, alteration, or repair of a sign is being done contrary to the provisions of this ordinance, another controlling ordinance or statute governing the sign, the building official may order the work stopped by notice verbally or in writing served on any persons engaged in the doing or causing such work to be done and the city shall post a STOP WORK ORDER on the property adjacent to the posted building permit, and any such persons shall forthwith stop such work until authorized by the building official to proceed with the work. If no permit has been issued, all work shall stop until a permit has been properly issued and all errors corrected to the satisfaction of the building official. The building official or code enforcement authority may also issue a work correction order, which shall be served upon any persons who are working on a certain aspect of the sign.

(d) The city and/or the City Administrator shall enforce this chapter by appropriate administrative action, including but not limited to, the rejection of plans, maps, plats and specifications not found to be in compliance with this ordinance and good engineering practices, and the issuance of stop work orders.

(e) Upon the request of the city council, the city attorney or other authorized attorney shall file an action in the district courts to enjoin the violation or threatened violation of this ordinance, or to obtain declaratory judgment, and to seek and recover court costs and attorney fees, and/or recover damages in an amount sufficient for the city to undertake any construction or other activity necessary to bring about compliance with a requirement regarding the property and established pursuant to this chapter