

CONTRACT

This contract made this 20th day of April, 2021 between, Franklin County, Florida, hereinafter called the COUNTY, and Walter Marine, hereinafter called the CONTRACTOR.

WITNESSETH, that the County and the Contractor for the consideration state herein agree as follows:

1. **SCOPE OF WORK.** See attached accepted proposal per RFP
2. **THE CONTRACT PRICE.** The County shall pay to the Contractor for the performance of this contract the sum as specified in the attached accepted proposal for said work not to exceed \$70,000.00.
3. **DURATION OF CONTRACT.** The contract shall take effect upon final execution and terminate **August 1, 2021**.
4. **ASSIGNMENTS.** This contract shall not be sublet, transferred, assigned or otherwise conveyed by the Contractor without prior written approval of the County.
5. **TERMINATION OF THIS CONTRACT.** The County reserves the right to terminate or suspend the contract in whole or in part at any time the interest of the County requires such termination or suspension. The County shall notify the Contractor in writing of such action with instructions as to the effective date of termination or suspension or specify the stage of work at which the action is to be taken.

If the County determines that the performance of the Contractor is not satisfactory, the County shall have the option of: (a) immediately terminating the contract, or (b) notifying the Contractor of the deficiency with a requirement that the deficiency be corrected within a specified time. Failure to correct such deficiencies in the specified time will result in the Contractor being declared in default and the contract may be terminated.

If the Contract is terminated for cause before the performance is completed, the Contractor shall be paid for the work units satisfactorily deployed and accepted at the contract unit price.

6. **DEFAULT OF CONTRACT.** If the Contractor fails to begin the work under the Contract the County shall have full power or authority, without violating the contract, to take the work out of the hands of the Contractor and to declare the contract in default.
7. **PRESERVATION OF PROPERTY.** The Contractor shall preserve from damage all property associated with, or which is in the vicinity of, or is in any way affected by the work. This applies to public and private property and/or utilities. Any damage occurring to such properties shall be immediately repaired at the expense of the Contractor.
8. **HOLD HARMLESS AND INSURANCE.** To the extent allowed by law, the Contractor shall Indemnify, defend, and save and hold harmless, the County, all of its officers, agents, or employees from all suits, actions, claims, demands, and liabilities of any nature whatsoever arising out of, because of, or due to breach of this agreement by the Contractor, its sub-contractors, agents, or employees or due to any negligent act or employees. Neither Contractor nor any of its subcontractors will be liable under this section for damages arising out of injury or damage to persons or property directly caused or resulting from the sole negligence of the County or any of its officers, agents, or employees.
9. **GENERAL LIABILITY INSURANCE.** The Contractor shall maintain general liability insurance or at least \$1,000,000 per person and property damage insurance, holding the County harmless for the contractor's negligence. The Contractor must provide Worker's Compensation Insurance on all employees working unless otherwise exempt. Certificates of such insurance shall be filed with the County prior to beginning work under this contract and shall be subject to approval for adequacy of protection.

10. **WORKER'S COMPENSATION INSURANCE.** The Contractor shall provide Worker's Compensation Insurance (including Longshoreman's) in accordance with the laws of the State of Florida and in amounts sufficient to secure the benefits of the Florida Worker's Compensation Law of all of its employees. The Contractor shall insure that the employees of a subcontractor are covered by similar insurance. Worker's Compensation exemptions will be accepted upon providing a current certificate, Articles of Incorporation, and a signed Franklin County Worker's Compensation Hold Harmless Agreement.
11. **PERMITS, RULES & REGULATIONS.** It shall be the Contractor's responsibility to secure all permits necessary to conduct the work in accordance with required regulations and to notify all applicable utilities or parties affected by the Contractor's operations. The Contractor shall further be responsible for all fees associated with the performance of this contract. The Contractor agrees to abide by all applicable State and Federal Laws, rules, and regulations.
12. **ACCESS TO RECORDS.** The Contractor agrees to provide access to those records, books and documentations that pertain to this project during the project period and for a three (3) year period thereafter.
13. **AUTHORIZED PERSONNEL.** The Contractor is to contact the following for any questions regarding this project: Erin Griffith, Franklin County Fiscal Manager / Grants Coordinator, 34 Forbes Street, Apalachicola, FL 32320, (850) 653-9783 Ext. 158, e-mail: erin@franklincountyflorida.com.
14. **LITIGATION.** If any litigation arises out of this Contract, venue of all such cases shall be Franklin County, Florida, and the prevailing party is entitled to a reasonable attorney fees and costs.
15. **SPECIAL CONDITIONS.** See attached accepted proposal per RFP.

In WITNESS WHEREOF, the parties hereto have caused this instrument, as the 20th day of April 2021.

FRANKLIN COUNTY
BOARD OF COUNTY COMMISSIONERS

By: _____
Ricky D. Jones, Chairman

ATTEST:

Michele Maxwell, Clerk

WALTER MARINE

By: _____
David Walter, Contractor

NOTARIZED SIGNATURE OF CONTRACTOR:

STATE OF _____, COUNTY OF _____

Print, Type of Stamp Commissioned Name of Notary Public

The forgoing instrument was acknowledged before me this ____ day of _____, _____ who is personally known or has produced _____ as identification.

Attachment C

CONFLICT OF INTEREST DISCLOSURE FORM

For purposes of determining any possible conflict of interest, all proposers/proposers, must disclose if any Franklin County, Florida employee(s), elected officials(s), of if any of its agencies is also an owner, corporate officer, agency, employee, etc., of their business.

Indicate either "yes" (an employee, elected official, or agency is also associated with your business), or "no". If yes, give person(s) name(s) and position(s) with your business.

YES _____ NO

NAME(S)	POSITION(S)	FIRM NAME:
_____	_____	_____
_____	_____	_____
_____	_____	_____

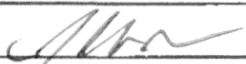
BY (PRINTED): David Walter D/B/A Walter Marine
BY (SIGNATURE): 
TITLE: Owner
ADDRESS: PO Box 998
Orange Beach, Al 36561
PHONE NO. 251-979-2200
E-MAIL reefmaker@gulftel.com

Attachment D

CERTIFICATIONS AND ASSURANCES

The County will not enter this Agreement unless Contractor completes the CERTIFICATIONS AND ASSURANCES contained in this Attachment. In performance of this Agreement, Contractor provides the following certifications and assurances:

- A. Debarment and Suspension Certification (2 CFR Part 1400)
- B. Certification Regarding Lobbying (31 U.S.C. 1352)
- C. Certification Regarding Public Entity Crimes (section 287.133, F.S.)
- D. Certification Regarding Drug-Free Workplace Requirements (41 U.S.C. 701 et. seq.) (as applicable to recipients and sub-recipients of federal financial assistance)
- E. Certification Regarding the Scrutinized Companies List (section 287.135, F.S.) (as applicable)

A. CERTIFICATION REGARDING DEBARMENT, SUSPENSION, AND OTHER RESPONSIBILITY MATTERS – PRIMARY COVERED TRANSACTION.

The undersigned Contractor certifies to the best of its knowledge and belief, that it and its principals:

1. Are not presently debarred, suspended, proposed for debarment, declared ineligible, or voluntarily excluded from covered transactions by a Federal department or agency;
2. Have not within a three-year period preceding this Agreement been convicted of or had a civil judgment rendered against them for commission of fraud or a criminal offense in connection with obtaining, attempting to obtain, or performing a public (Federal, State, or local) transaction or contract under a public transaction; violation of Federal or State antitrust statutes or commission of embezzlement, theft, forgery, bribery, falsification or destruction of records, making false statements, or receiving stolen property;
3. Are not presently indicted or otherwise criminally or civilly charged by a government entity (Federal, State or local) with commission of any of the offenses enumerated in paragraph A.2. of this certification; and/or
4. Have not within a three-year period preceding this application/proposal had one or more public transactions (Federal, State, or local) terminated for cause of default.

If Contractor is unable to certify to any of the statements in this certification, Contractor shall attach an explanation to this Agreement.

B. CERTIFICATION REGARDING LOBBYING – Certification for Contracts, Grants, Loans, and Cooperative Agreements.

The undersigned Contractor certifies, to the best of his /her knowledge and belief, that: 12/14/2020 3 No Federal appropriated funds have been paid or will be paid, by or on behalf of the undersigned, to any person for influencing or attempting to influence an officer or employee of Congress, or an employee of a Member of Congress in connection with the awarding of any Federal contract, the making of any Federal

grant, the making of any Federal loan, the entering into of any cooperative agreement, and the extension, continuation, renewal, amendment or modification of any Federal contract, grant, loan or cooperative agreement.

If any funds other than Federal appropriated funds have been paid or will be paid to any person for influencing or attempting to influence an officer or employee of any agency, a Member of Congress, an officer or employees of Congress, or employee of a Member of Congress in connection with a Federal contract, grant, loan, or cooperative agreement, the undersigned shall also complete and submit Standard Form – LLL, "Disclosure Form to Report Lobbying," in accordance with its instructions.

The undersigned shall require that language of this certification be included in the documents for all subcontracts at all tiers (including subcontracts, sub-grants and contracts under grants, loans and cooperative agreements) and that all sub-recipients and contractors shall certify and disclose accordingly.

This certification is a material representation of fact upon which reliance was placed when this Grant was made or entered into. Submission of this certification is a prerequisite for making or entering into this Agreement imposed by 31 U.S.C. 1352. Any person who fails to file the required certification shall be subject to a civil penalty of not less than \$10,000 and not more than \$100,000 for each such failure.

C. CERTIFICATION REGARDING PUBLIC ENTITY CRIMES, SECTION 287.133, F.S.:

Contractor hereby certifies that neither it, nor any person or affiliate of Contractor, has been convicted of a Public Entity Crime as defined in section 287.133, F.S., nor placed on the convicted vendor list.

Contractor understands and agrees that it is required to inform the City immediately upon any change of circumstances regarding this status.

D. CERTIFICATION REGARDING DRUG-FREE WORKPLACE REQUIREMENTS

(If Contractor is a Recipient of Sub-recipient of Federal Financial Assistance)

Pursuant to the Drug-Free Workplace Act of 1988, the undersigned attests and certifies that the Grantee (if not an individual) will provide a drug-free workplace by the following actions:

1. Publishing a statement notifying employees that the unlawful manufacture, distribution, dispensing, possession or use of a controlled substance is prohibited in Contractor's workplace and specifying the actions that will be taken against employees for violation of such prohibition.
2. Establishing an ongoing drug-free awareness program to inform employees concerning:
 - a. The dangers of drug abuse in the workplace.
 - b. The policy of maintaining a drug-free workplace.
 - c. Any available drug counseling, rehabilitation and employee assistance programs.
 - d. The penalties that may be imposed upon employees for drug abuse violations occurring in the workplace. 12/14/2020 4
3. Making it a requirement that each employee to be engaged in the performance of the Agreement be given a copy of the statement required by paragraph D.1. of this certification.

4. Notifying the employee in the statement required by paragraph D.1. of this certification that, as a condition of employment under the Agreement, the employee will:

a. Abide by the terms of the statement.

b. Notify the employer in writing of his or her conviction for a violation of a criminal drug statute occurring in the workplace no later than five (5) calendar days after such conviction.

5. Notifying the County in writing ten (10) calendar days after receiving notice under subparagraph 4.b. from an employee or otherwise receiving actual notice of such conviction. Provide such notice of convicted employees, including position title, to every Grant Manager on whose Grant activity the convicted employee was working. The notice shall include the identification number(s) of each affected Contract or Grant.

6. Taking one of the following actions, within thirty (30) calendar days of receiving notice under subparagraph 4.b. herein, with respect to any employee who is so convicted:

a. Taking appropriate personnel action against such an employee, up to and including termination, consistent with the requirements of the Rehabilitation Act of 1973 as amended.

b. Requiring such employee to participate satisfactorily in drug abuse assistance or rehabilitation program approved for such purposes by a Federal, State or local, health, law enforcement, or other appropriate agency.

7. Making a good faith effort to continue to maintain a drug-free workplace through implementation of this entire certification.

If the Contractor is an individual, the Contractor certifies that:

1. As a condition of the grant, Contractor will not engage in the unlawful manufacture, distribution, dispensing, possession, or use of a controlled substance in conducting any activity with the grant; and,

2. If convicted of a criminal drug offense resulting from a violation occurring during the conduct of any grant activity, Contractor will report the conviction, in writing, within 10 calendar days of the conviction, to the County. When notice is made to such a central point, it shall include the identification number(s) of each affected grant.

E. CERTIFICATION REGARDING the SCRUTINIZED COMPANIES LISTS, SECTION 287.135, F.S.

If this Grant is in the amount of \$1 million or more, in accordance with the requirements of section 287.135, F.S., Grantee hereby certifies that it is not listed on either the Scrutinized Companies with Activities in Sudan List or the Scrutinized Companies with Activities in the Iran Petroleum Energy Sector List. Both lists are created pursuant to section 215.473, F.S. Grantee/Contractor also hereby certifies that it is not engaged in business operations in Cuba or Syria.

County/Contractor understand that pursuant to section 287.135, F.S., the submission of a false certification may subject Grantee/Contractor to civil penalties, attorney's fees, and/or costs.

If Grantee/Contractor is unable to certify to any of the statements in this certification, Grantee/Contractor shall attach an explanation to this Grant.

By signing below, Grantee/Contractor certifies the representations outlined in parts A through E above are true and correct.

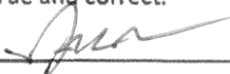

Date: 3/29/21

(Signature and titles of authorized representative)

David Walter D/B/A Walter Marine

(Street)

PO Box 998

(City, State, ZIP Code)

Orange Beach, AL 36561

**Attachment E
CERTIFICATION REGARDING DEBARMENTS, SUSPENSION, INELIGIBILITY AND
VOLUNTARY EXCLUSION-LOWER TIER FEDERALLY FUNDED TRANSACTIONS**

Required for all contractors and subcontractors on procurement (vendor) contracts of \$100,000 or more, and for all contracts and grants with sub-recipients regardless of amount, when funded by a federal grant.

1. The undersigned hereby certifies that neither it nor its principals is presently debarred, suspended, proposed for debarment, declared ineligible, or voluntarily excluded from participation in this transaction by any Federal department or agency.
2. The undersigned also certifies that it and its principals:
 - (a) Have not within a three-year period preceding this response been convicted of or had a criminal offense in connection with obtaining, attempting to obtain, or performing a public (Federal, State or local) transaction or contract under a public transaction; violation of Federal or State anti-trust statutes or commission of embezzlement, theft, forgery, bribery, falsification or destruction of records, making false statements, or receiving stolen property.
 - (b) Are not presently indicted for or otherwise criminally or civilly charged by a governmental entity (Federal, State or local) with commission of any of the offenses enumerated in paragraph 2.(a) of this Certification; and
 - (c) Have not within a three-year period preceding this certification had one or more public transactions (Federal, State or local) terminated for cause or default.
3. Where the undersigned is unable to certify to any of the statements in this certification, an explanation shall be attached to this certification.

Dated this 29 day of MARCH, 2021

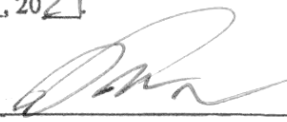
By: 
Authorized Signature/Contractor

David Walter Owner
Typed Name/Title

David Walter D/B/A Walter Marine
Grantee Name/Contractor Name

22605 Andrews Lane
Street Address

Building, Suite Number

Orange Beach, AL 36561
City/State/Zip Code

251-979-2200
Area Code/Telephone Number

**INSTRUCTIONS FOR CERTIFICATION REGARDING DEBARMENT,
SUSPENSION, INELIGIBILITY AND VOLUNTARY EXCLUSION-
LOWER TIER FEDERALLY FUNDED TRANSACTIONS**

1. By signing and submitting this form, the certifying party is providing the certification set out below.
2. The certification in this clause is a material representation of fact upon which reliance was placed when this transaction was entered into. If it is later determined that the certifying party knowingly rendered an erroneous certification, in addition to other remedies available to the Federal Government, the Florida Fish and Wildlife Conservation Commission (FWC) or agencies with which this transaction originated may pursue available remedies, including suspension and/or debarment.
3. The certifying party shall provide immediate written notice to the person to which this contract is submitted if at any time the certifying party learns that its certification was erroneous when submitted or has become erroneous by reason of changed circumstances.
4. The terms covered transaction, debarred, suspended, ineligible, lower tier covered transaction, participant, person, primary covered transaction, principal, proposal, and voluntarily excluded, as used in this clause, have the meanings set out in the Definitions and Coverage sections of rules implementing Executive Order 12549. You may contact the person to which this contract is submitted for assistance in obtaining a copy of those regulations.
5. The certifying party agrees by submitting this contract that, should the proposed covered transaction be entered into, it shall not knowingly enter into any lower tier contract, or other covered transaction with a person who is debarred, suspended, declared ineligible, or voluntarily excluded from participation in this covered transaction, unless authorized by the FWC or agency with which this transaction originated.
6. The certifying party further agrees by executing this contract that it will include this clause titled "Certification Regarding Debarment, Suspension, Ineligibility and Voluntary Exclusion-Lower Tier Covered Transaction," without modification, in all contracts or lower tier covered transactions and in all solicitations for lower tier covered transactions.
7. A participant in a covered transaction may rely upon a certification of a prospective participant in a lower tier covered transaction that it is not debarred, suspended, ineligible, or voluntarily excluded from the covered transaction, unless it knows that the certification is erroneous. A participant may decide the method and frequency by which it determines the eligibility of its principals. Each participant may, but is not required to, check the Nonprocurement List (Telephone No. (202) 501-4740 or (202) 501-4873.)
8. Nothing contained in the foregoing shall be construed to require establishment of a system of records in order to render in good faith the certification required by this clause. The knowledge and information of a participant is not required to exceed that which is normally possessed by a prudent person in the ordinary course of business dealings.
9. Except for transactions authorized under paragraph 5 of these instructions, if a participant in a covered transaction knowingly enters into a lower tier covered transaction with a person who is suspended, debarred, ineligible, or voluntarily excluded from participation in this transaction, in addition to other remedies available to the Federal Government, the FWC or agency with which this transaction originated may pursue available remedies, including suspension and/or debarment.

ACORD

Client#: 26207 WALMA4
CERTIFICATE OF LIABILITY INSURANCE

DATE (MM/DD/YYYY)
 03/23/2021

THIS CERTIFICATE IS ISSUED AS A MATTER OF INFORMATION ONLY AND CONFERS NO RIGHTS UPON THE CERTIFICATE HOLDER. THIS CERTIFICATE DOES NOT AFFIRMATIVELY OR NEGATIVELY AMEND, EXTEND OR ALTER THE COVERAGE AFFORDED BY THE POLICIES BELOW. THIS CERTIFICATE OF INSURANCE DOES NOT CONSTITUTE A CONTRACT BETWEEN THE ISSUING INSURER(S), AUTHORIZED REPRESENTATIVE OR PRODUCER, AND THE CERTIFICATE HOLDER.

IMPORTANT: If the certificate holder is an ADDITIONAL INSURED, the policy(ies) must have ADDITIONAL INSURED provisions or be endorsed. If SUBROGATION IS WAIVED, subject to the terms and conditions of the policy, certain policies may require an endorsement. A statement on this certificate does not confer any rights to the certificate holder in lieu of such endorsement(s).

PRODUCER Lyon Fry Cadden Ins Agency Inc P. O. Box 160927 (251) 473-4600 Mobile, AL 36616	CONTACT NAME: Becky Ward
	PHONE (A/C, No, Ext): 251 473-4600 FAX (A/C, No): 251-450-0032 E-MAIL ADDRESS: bward@lyonfrycadden.com
INSURER(S) AFFORDING COVERAGE	
INSURER A: Market American Insurance Company	NAIC # 28932
INSURER B:	
INSURER C:	
INSURER D:	
INSURER E:	
INSURER F:	

INSURED
 David Walter dba Walter Marine
 P. O. Box 998
 Orange Beach, AL 36561

COVERAGES CERTIFICATE NUMBER: REVISION NUMBER:

THIS IS TO CERTIFY THAT THE POLICIES OF INSURANCE LISTED BELOW HAVE BEEN ISSUED TO THE INSURED NAMED ABOVE FOR THE POLICY PERIOD INDICATED. NOTWITHSTANDING ANY REQUIREMENT, TERM OR CONDITION OF ANY CONTRACT OR OTHER DOCUMENT WITH RESPECT TO WHICH THIS CERTIFICATE MAY BE ISSUED OR MAY PERTAIN, THE INSURANCE AFFORDED BY THE POLICIES DESCRIBED HEREIN IS SUBJECT TO ALL THE TERMS, EXCLUSIONS AND CONDITIONS OF SUCH POLICIES. LIMITS SHOWN MAY HAVE BEEN REDUCED BY PAID CLAIMS.

INSR LTR	TYPE OF INSURANCE	ADDL INSR	SUBR INSR	POLICY NUMBER	POLICY EFF (MM/DD/YYYY)	POLICY EXP (MM/DD/YYYY)	LIMITS
A	<input checked="" type="checkbox"/> COMMERCIAL GENERAL LIABILITY <input type="checkbox"/> CLAIMS-MADE <input checked="" type="checkbox"/> OCCUR <input checked="" type="checkbox"/> B/WPD Ded:2,500 GENL AGGREGATE LIMIT APPLIES PER: <input type="checkbox"/> POLICY <input type="checkbox"/> PRO-JECT <input type="checkbox"/> LOC OTHER:			9CC8272311	06/01/2020	06/01/2021	EACH OCCURRENCE: \$1,000,000 DAMAGE TO RENTED PREMISES (Ea occurrence): \$50,000 MED EXP (Any one person): \$5,000 PERSONAL & ADV INJURY: \$1,000,000 GENERAL AGGREGATE: \$2,000,000 PRODUCTS - COMPROP AGG: \$1,000,000 \$
	AUTOMOBILE LIABILITY <input type="checkbox"/> ANY AUTO OWNED AUTOS ONLY <input type="checkbox"/> HIRED AUTOS ONLY <input type="checkbox"/> SCHEDULED AUTOS <input type="checkbox"/> NON-OWNED AUTOS ONLY						COMBINED SINGLE LIMIT (Ea accident): \$ BODILY INJURY (Per person): \$ BODILY INJURY (Per accident): \$ PROPERTY DAMAGE (Per accident): \$ \$
	UMBRELLA LIAB <input type="checkbox"/> OCCUR EXCESS LIAB <input type="checkbox"/> CLAIMS-MADE DED RETENTION \$						EACH OCCURRENCE: \$ AGGREGATE: \$ \$
	WORKERS COMPENSATION AND EMPLOYERS' LIABILITY ANY PROPRIETOR/PARTNER/EXECUTIVE OFFICER/MEMBER EXCLUDED? (Mandatory in NH) If yes, describe under DESCRIPTION OF OPERATIONS below						<input type="checkbox"/> Y <input checked="" type="checkbox"/> N <input type="checkbox"/> I <input type="checkbox"/> M <input type="checkbox"/> N/A PER STATE: OTH-ER:
A	P&I Coverage (2) Crew Coverage			9CC827311	06/01/2020	06/01/2021	Included in Liability \$2,500 Deductible

DESCRIPTION OF OPERATIONS / LOCATIONS / VEHICLES (ACORD 101, Additional Remarks Schedule, may be attached if more space is required)
 Classification Limitation: Manufacture & Placement of Artificial Reefs and non-emergency vessel assistance.

CERTIFICATE HOLDER Franklin County 33 Market Street Apalachicola, FL 32320	CANCELLATION SHOULD ANY OF THE ABOVE DESCRIBED POLICIES BE CANCELLED BEFORE THE EXPIRATION DATE THEREOF, NOTICE WILL BE DELIVERED IN ACCORDANCE WITH THE POLICY PROVISIONS.
	AUTHORIZED REPRESENTATIVE <i>Elizabeth C. Lyon, Sr.</i>

State of Florida

Department of State

I certify from the records of this office that WALTER MARINE is a Fictitious Name registered with the Department of State on May 8, 2002.

The Registration Number of this Fictitious Name is G02128900237.

I further certify that said Fictitious Name Registration is active.

I further certify that said Fictitious Name Registration filed a renewal on June 6, 2017, and expires on December 31, 2022.

Given under my hand and the Great Seal of Florida, at Tallahassee, the Capital, this the Seventh day of June, 2017

Ken DeFina

Secretary of State



Authentication ID: **100300043281-060717-G02128900237**

To authenticate this certificate, visit the following site, enter this ID, and then follow the instructions displayed.

<https://efile.sunbiz.org/certauthver.html>



TOWN OF DAVIE
Business Tax Receipts Division
6591 Orange Drive, Davie, FL 33314
Telephone: 954-797-1212
Email: btr@davie-fl.gov
Website: www.davie-fl.gov

Business Name: WALTER MARINE
Address: 4651 SW 74 TER

City, ST, Zip: DAVIE, FL, 33314

	<p style="text-align: center;">TOWN OF DAVIE Business Tax Receipt Effective Date: 10/1/2020 Expiration Date: 9/30/2021</p>	<p style="text-align: center;">License Number 158</p>
<p>DBA Name: _____ Business Phone: (251) 979-2200 Business Name: WALTER MARINE Square Footage: _____ Address: 4651 SW 74 TER City, ST, Zip: Davie, FL, 33314</p>		
<p style="text-align: center;">License Type: Offices Desk Space No Stock</p>		
<p style="text-align: center;">CERTIFICATE OF USE</p>		
<p>*The Business Tax Receipt is an acknowledgment that a Business Tax has been paid pursuant to Sec. 13-17 of the Town Code. Please contact the Towns Business Tax Receipt Division if the business has ceased, moved or changed ownership.</p> <p>**The Certificate of Use is an acknowledgment that the business was determined to have met the requirements of Sec. 12-382 of the Town Code. If blank, Certificate of Use details are on file with Business Tax Receipts Division.</p>		



Company ID Number: 973968

Approved by:

Employer Walter Manne	
Name (Please Type or Print) David M Walter	Title
Signature Electronically Signed	Date 05/23/2016
Department of Homeland Security – Verification Division	
Name (Please Type or Print) USCIS Verification Division	Title
Signature Electronically Signed	Date 05/23/2016



Company ID Number: 373968

Information Required for the E-Verify Program	
Information relating to your Company:	
Company Name	Water Marine
Company Facility Address	22605 Andrews Lane Orange Beach, AL 36561
Company Alternate Address	PO Box 698 Orange Beach, AL 36561
County or Parish	BALDWIN
Employer Identification Number	██████████
North American Industry Classification Systems Code	339
Parent Company	
Number of Employees	1 to 4
Number of Sites Verified for	1

FRANKLIN COUNTY, FLORIDA

2021 BUDDY WARD ARTIFICIAL REEF PROJECT

**REQUEST FOR PROPOSALS
ADDENDUM #1 DATED 03/22/21
RFP # 2020-01**

Contractor must comply with ALL federal requirements listed in the attached FWC Grant Agreement 20011

RECEIVED

A handwritten signature in black ink, appearing to be a stylized name or initials, located below the word 'RECEIVED'.



WALTER MARINE
— ARTIFICIAL REEFS —

www.reefmaker.net
251-979-2200

Walter Marine offers the following reefs for consideration to
Franklin County
2021 ARTIFICIAL REEF PROJECT



General Information:

Walter Marine

4651 SW 74th Terrace Dr.

Davie, FL 33314-4127

Main Office:

PO Box 998

22605 Andrews Lane

Orange Beach, AL 36561

251-979-2200

Fax 251-967-2022

SSN# [REDACTED]

www.reefmaker.com

Established 1968

Sole Proprietorship-David Walter D/B/A Walter Marine

Florida Secretary of State Fictitious Name - Doc. G02128900237

Davie, FL business license #158

Walter Marine was founded by David Walter in 1968 as a vessel repair/shipyard. Walter Marine/Reefmaker was founded in 1986 as the first commercial artificial reef builder on the Gulf Coast. In 1996, we built our first manufactured reef. Our business has grown over the years to include the only Corps of Engineers approved snorkeling reef and an innovative wave attenuator/reef. We have franchises on the east coast of Florida & mid Atlantic states. To date we have deployed over 50,000 artificial reefs. We have an active R&D department that continually experiments with new designs and uses for our products. Our reefs are designed for 100+ year life cycles. We produce different reef models for Snapper, Grouper, juvenile fish, estuary enhancement, snorkeling, oyster restoration and wave attenuation. In addition, we have deployed 24 ships as artificial reefs.

PERSONNEL:

Name: David Walter

Owner/Operator of Walter Marine since founded in 1968.

Time in present position: 52 years

Total years experience in marine operations: 60 years

Veteran: United States Marine Corps 1966-1968, Disabled Vietnam Veteran, Honorably Discharged

Faulkner State College 1969-1971

Licensed pilot single engine seaplane

Licensed Marine Habitat Scientist

100-ton USCG license (expired)

Seventeen years as owner and operator of a shipyard

Thirty-four years experience as an artificial reef builder



PERSONNEL:

Name: Stewart Walter
Current Manager of Walter
Marine.

Time in present position: 20
years

32 years total experience with
Walter Marine

Auburn University 2005-2006

Licensed 200-ton US Coast
Guard Captain

Licensed Marine Habitat
Scientist



1. Material Specifications

Small Tetrahedron Reef

Florida Limestone Reef by Walter Marine

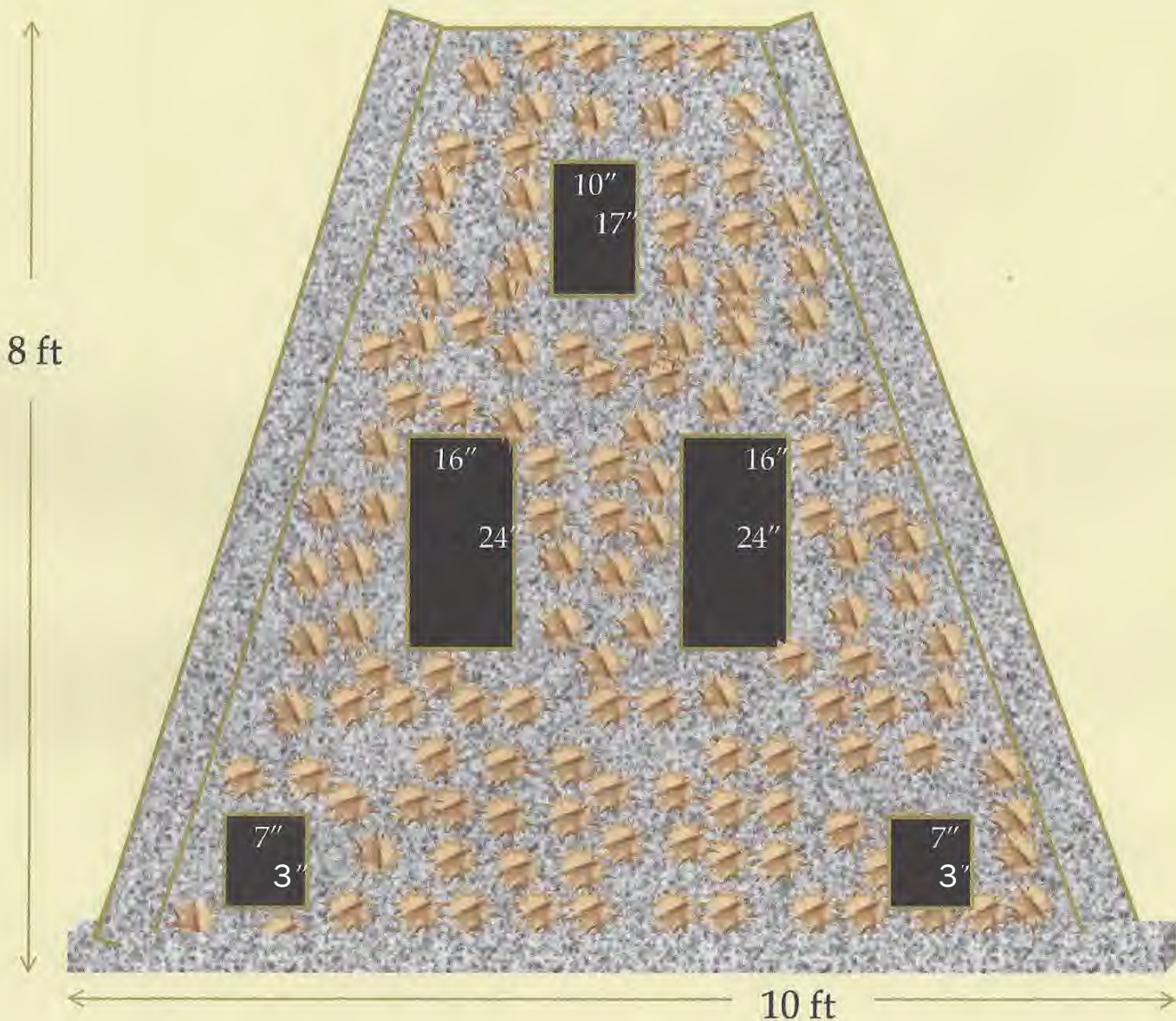
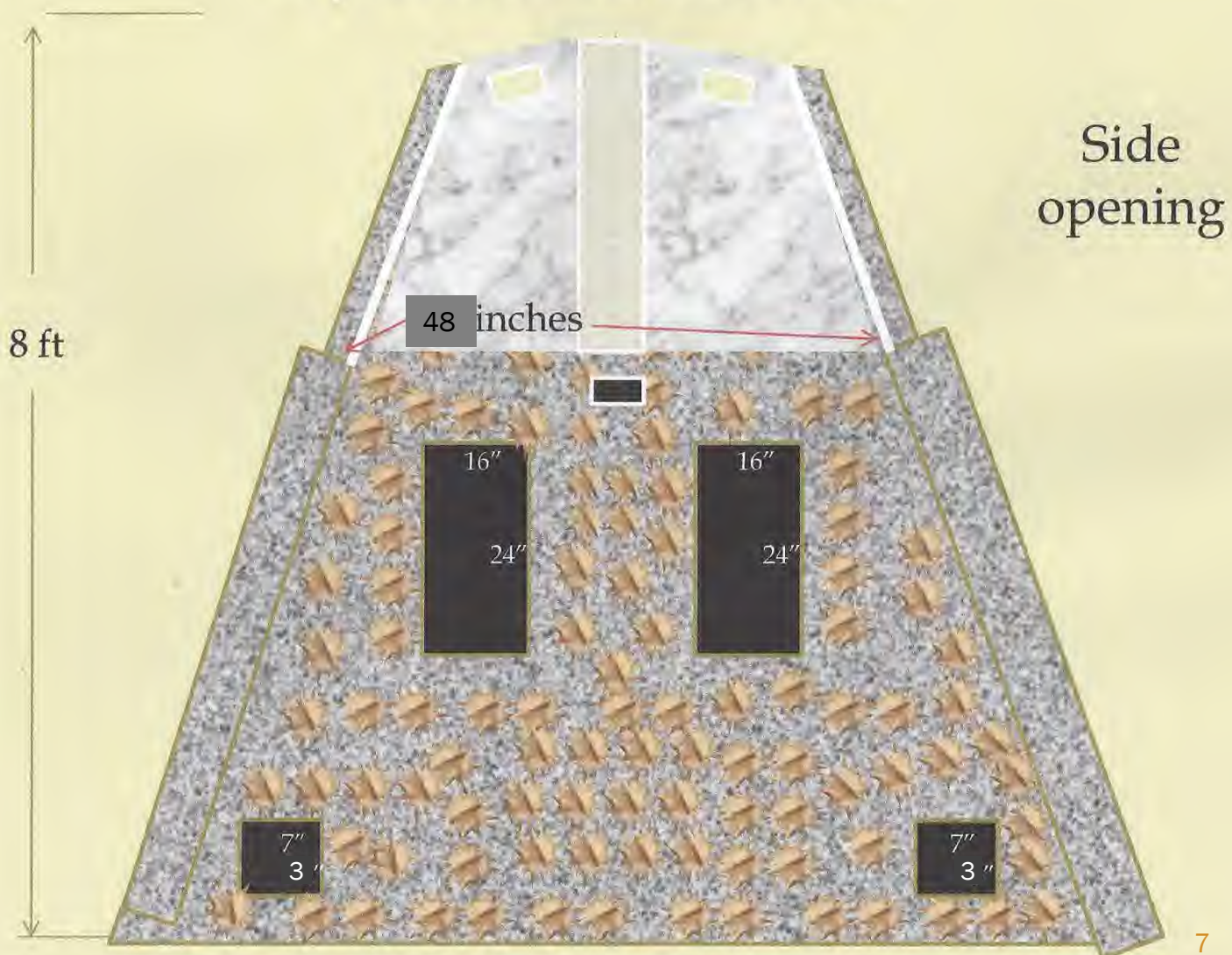

Figure 1

Florida Limestone w/ turtle Excluder



3" Thick Concrete Tetrahedron Reef With Florida Limestone Inbed

With Shortened Panel For Turtle Egress

Total Surface Area: 382.11 sqft
 Outer Surface Area: 142.62 sqft
 Volume: 37.77 cubic feet
 Window Area: 16.15 sqft

note: window area does not
 include turtle exculsion area

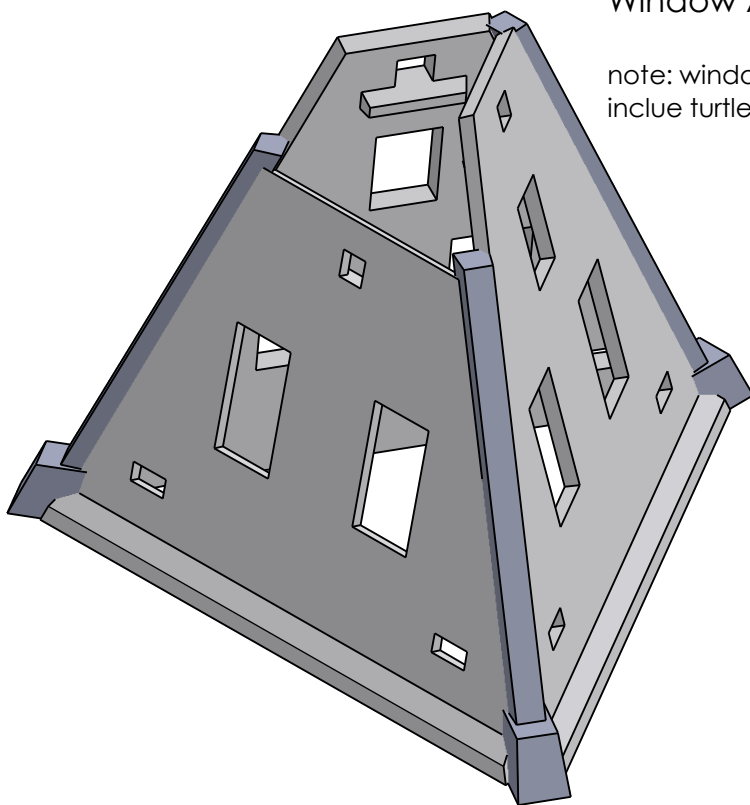

Isometric View: NOT TO SCALE
 For Viewing Purpose Only



8' Flar	
SIZE DWG. NO.	1
A	
SCALE: 1:64	Date: October 13, 2018

2

Figure 3

1

ITEM NO.	PART NUMBER	DESCRIPTION	QTY.
2	8' flar long panel	Made of Concrete and Limestone	2
2	8' flar short panel	Made of Concrete and Limestone	1
3	8' flar holder	Made of Concrete	1

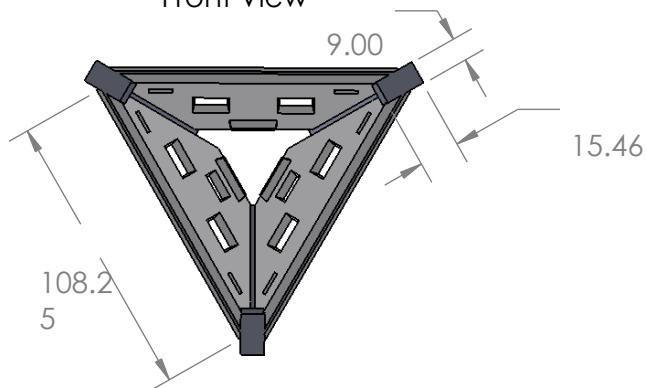
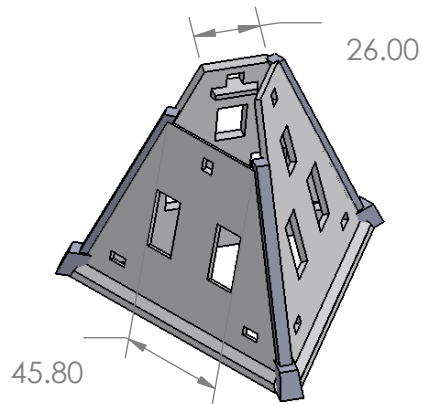
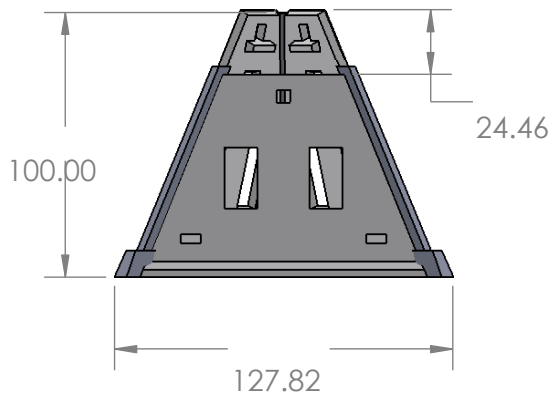
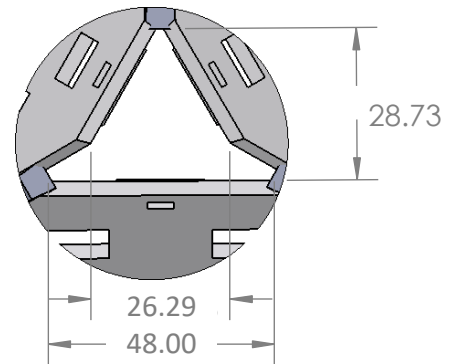
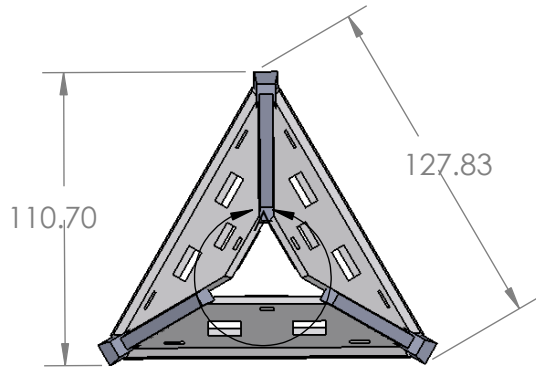

Scale: 1:64
Sheet 2 of 3

9

Figure 4

Window Holes	Width (in)	Height (in)
1	7.50	3.50
2	5.00	5.00
3	10.00	16.50
4	12.50	23.50

B

B

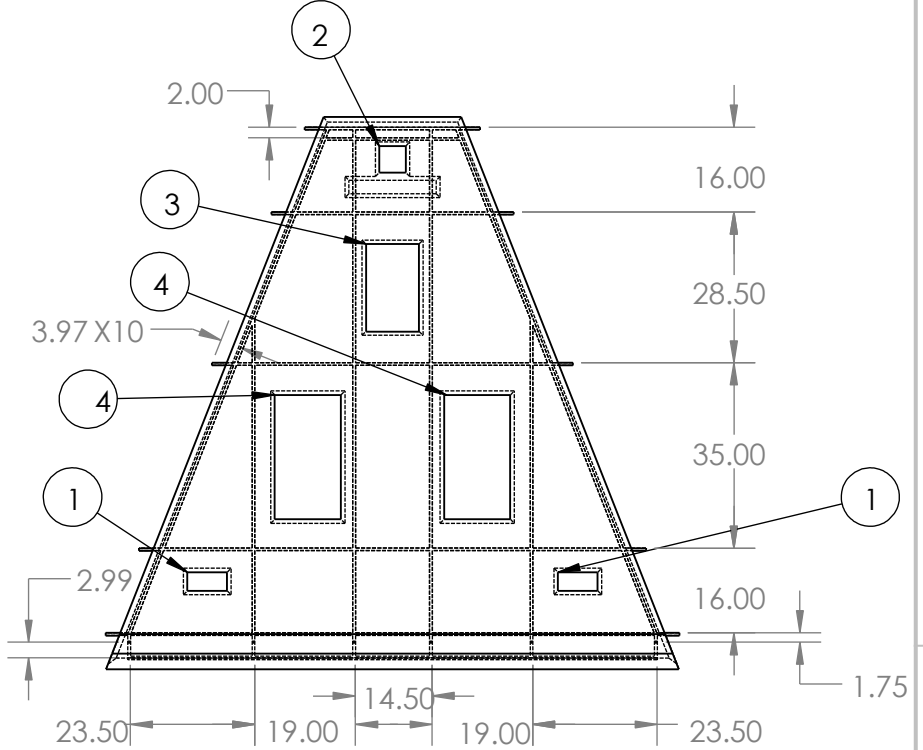

A

A

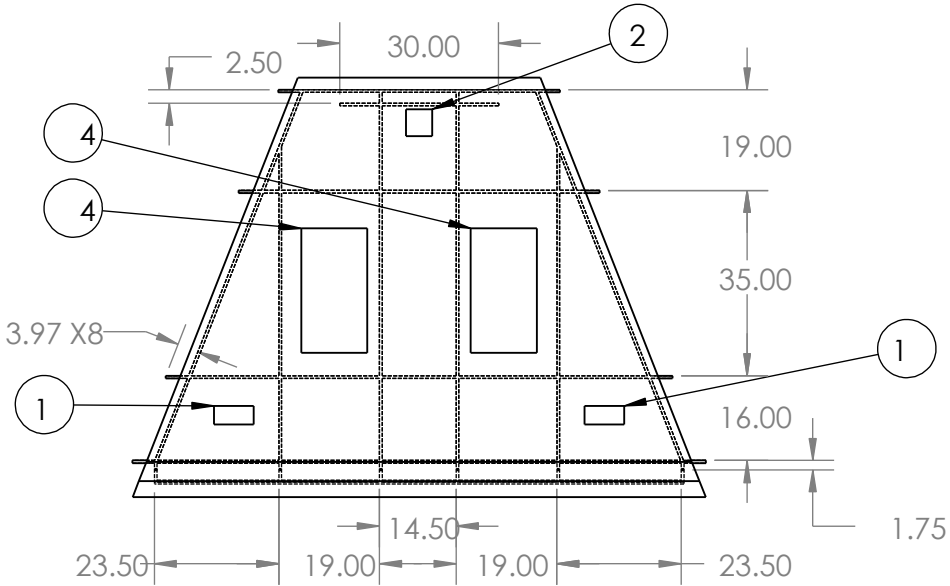

Scale: 1:64
Sheet 3 of 3

Figure 5



READY MIX USA
CONCRETE SOLUTIONS

Mix Design Report

Client : Walter Marine	Date : 12/18/2015
Project/Contract : 2015-358 - Precast Yard / 2015-358 - OB,Alabama	
Placement :	
Usage : Reefs	
Mix Design No. : 1528340 (1)	Description : 4000 PSI @ 28 Days

Compressive Strength	4 000 psi at 28 Days	Submittal No.	2015-358 - 358
Aggregate Size	#7 River Gravel	Plant	DOC MCDUFFIE - PLANT 1
Air %	4.0% ± 1.5%	Volume	27.00 ft ³
w/cm Ratio	0.37	U.W. at 3.0 % of air	146.1 lb/ft ³
Slump	6.00 to 8.00in	Slump with SuperP	

Constituents and Suppliers	Quantity (yd ³)	Sp. Gr. SSD	Volume
Cement - 101 - Cement III - Cement - .	564 lb	3.150	2.87 ft ³
Cement - 110 - Class F Flyash P303 - Class F Flyash - .	141 lb	2.410	0.94 ft ³
Water - 601 - City Water - City Water - City	31.0 Gal	1.000	4.14 ft ³
Stone - 227 - #7 River Gravel - Natural Gravel - .	1810 lb	2.630	11.02 ft ³
Sand - 301 - C-33 Natural Sand - Natural Sand - .	1171 lb	2.630	7.13 ft ³
Admixture - 402 - WRDA 64 - Low Range Water Reducers - W. R. Grace, Lithonia /	21.15 oz/yd ³	1.000	0.02 ft ³ /
Admixture - 442 - ADVA 140 - High Range Water Reducers - W. R. Grace, Lithonia /	63.45 oz/yd ³	1.000	0.07 ft ³ /
Air Volume			0.81 ft³
Total	3945 lb		27.00 ft³

Optional Products :

Remarks :
 003 - This mix will meet design strength requirements, at the specified age when testing and curing are performed using applicable ASTM and/or ACI standards. Please provide our office with copies of all test results per ASTM C94 14.4.

Prepared by : Patrick Brown, Quality Control	Approved by :
Date : 12/18/2015	Date : / /

DOC MCDUFFIE - PLANT 1
 21551 DOC MCDUFFIE RD

BOWSER-MORNER, INC.

Delivery / Mailing Address: 3016 Commerce Square South • Birmingham, Alabama 35210

AASHTO/ISO 17025 Accredited

LABORATORY REPORT

Report To: Walter Marine / Reefmaker
 Attn: David Walter
 P.O. Box 998
 Orange Beach, AL 36561

Report Date: June 8, 2017
Job No.: 179970
Report No.: 500546
No. of Pages: 2

Report On: Laboratory Analysis of One Set of Five Limestone Riprap Specimens
 Source: Walter Marine – Orange Beach, AL

On June 6, 2017, one set of five limestone riprap specimens were submitted for selected laboratory analysis from the above referenced source. Testing was performed as specified by the client and in accordance with the following procedures:

ASTM D 6473, "Specific Gravity and Absorption of Rock for Erosion Control".

Results are detailed on the attached data sheet.

Should you have any questions or if we may be of further service, please contact me at (205) 956-8805, extension 201.

Respectfully submitted,
 BOWSER-MORNER, INC.



Clark H. Lamb, Laboratory Manager
 Construction Materials Laboratory
 Construction Services Division
 Southeast US Region

CHL/kaf/chi
 500546
 l-File
 l-BMI
 l-reefmaker@gulftel.com

TABLE I
 Summary of Results

Test Parameter	Test Method	1	2	3	4	5	Average
Bulk Dry Specific Gravity:	ASTM D 6473	2.474	2.201	2.272	1.747	2.211	2.181
Bulk SSD Specific Gravity:	ASTM D 6473	2.558	2.315	2.419	1.933	2.361	2.317
Apparent Specific Gravity:	ASTM D 6473	2.700	2.486	2.663	2.146	2.602	2.519
Absorption, %:	ASTM D 6473	3.4	5.2	6.5	10.6	6.8	6.5
SSD Density, pcf:	ASTM D 6473	159.6	144.5	150.9	120.6	147.3	144.6

Figure 7

With Current Deflector

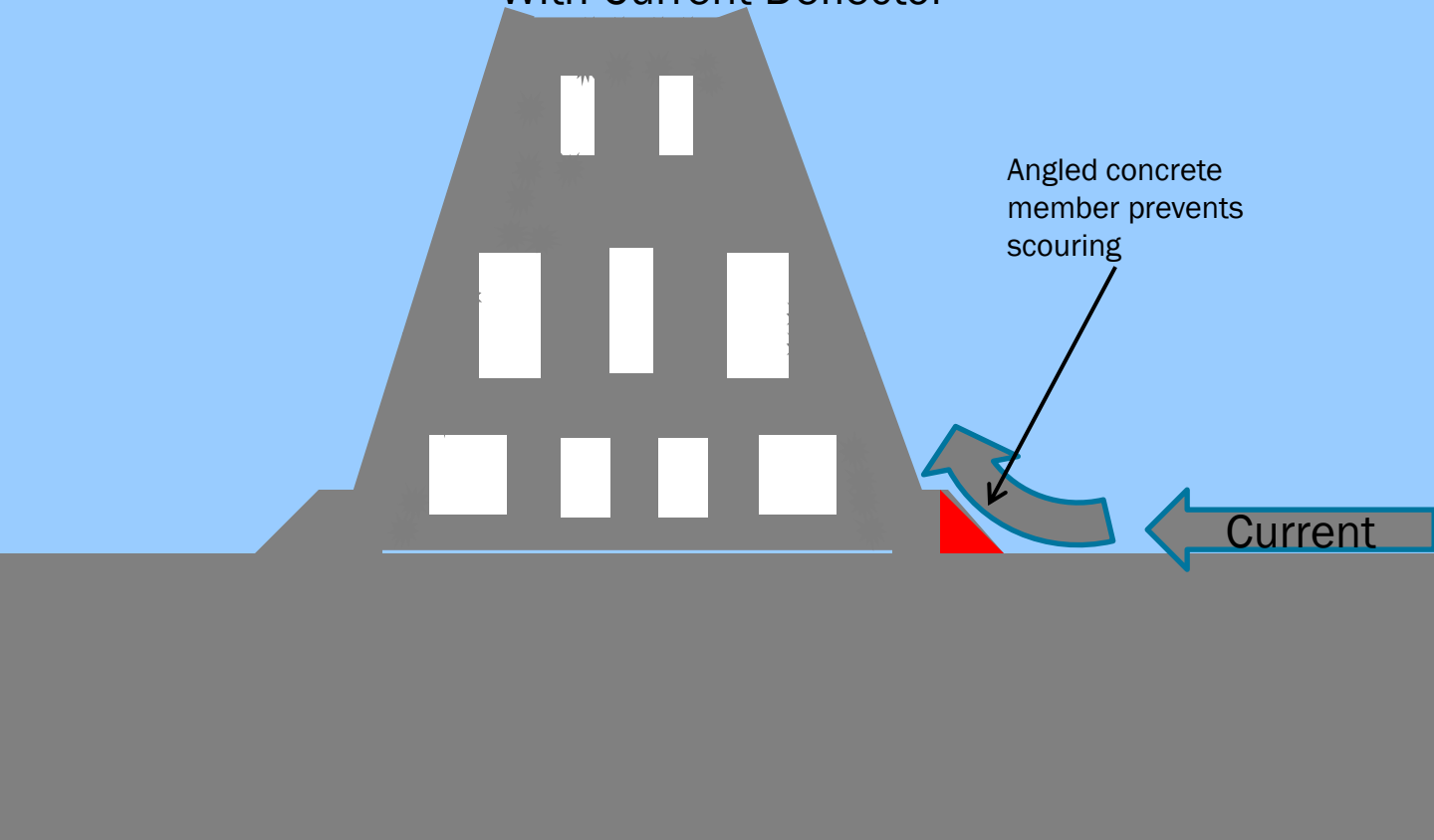

Without Current Deflector

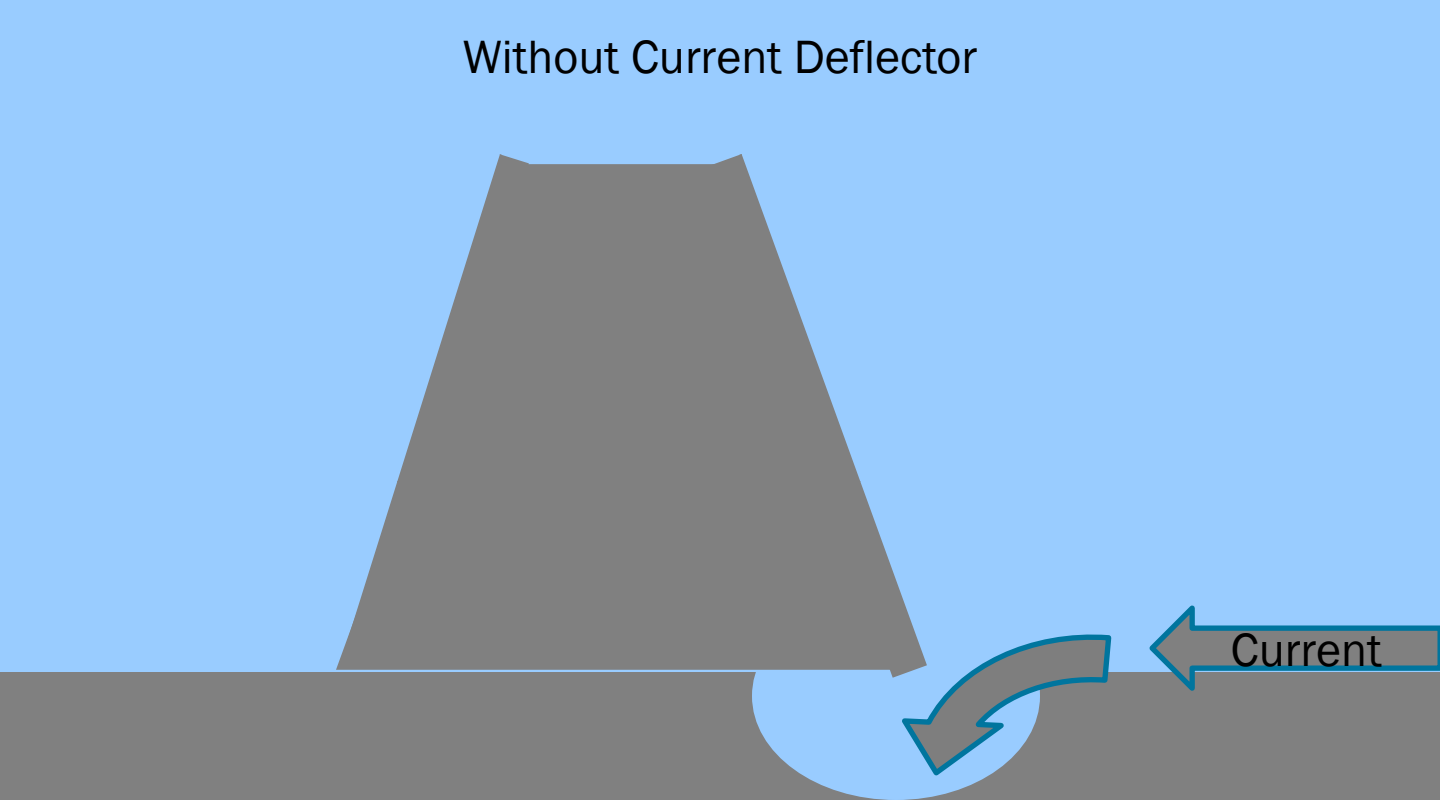

Florida Limestone Reef

MODULE SPECIFICATIONS:

1. Reef is built under Patent No. 7513711 for embedding limestone rocks into the sides of the reef. Florida Limestone rocks are the perfect PH for all marine life to live, even boring animals. **It's the only manufactured reef that can support all the marine life that lives on a natural reef.**

(See Figure 6)

2. Each unit is 8' tall with a 130" triangular base

3. Materials used: Concrete, (See Figure 5) rebar & Florida Limestone rocks.

4. Detailed drawing (See Figure 1-4)

5. Three isosceles trapezoid panels are cast with protruding rebar.

6. The panels are 3 inches thick

7. The panels are set into a jig and the protruding rebar is welded together.

8. Molds are placed on the three corners and concrete is poured to seal the corners & connecting rebar.

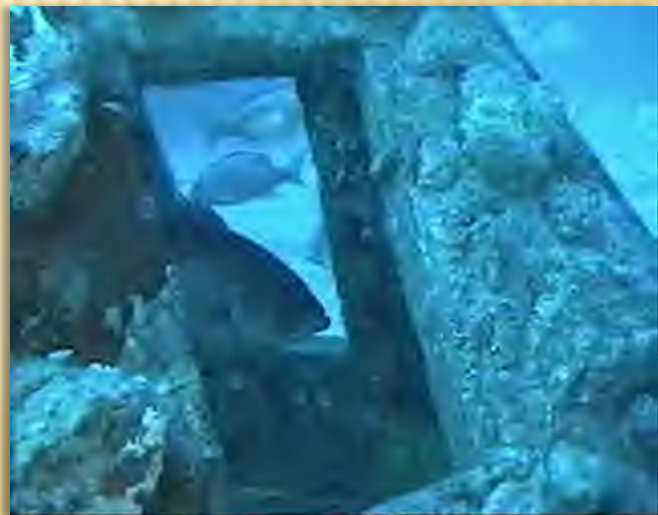

Florida Limestone Reef

MODULE SPECIFICATIONS:

9. 270 feet of welded #4 (1/2 inch) rebar comprise rebar framework. Meets or exceeds DOT method of welding rebar. The heavy welded rebar framework makes the reef virtually indestructible.

(See Figure 4)

10. #4,000 lb concrete mix

11. No external frame is used and no exposed rebar or metal.

12. Weight 5,500-6,000 lbs.

13. Each unit contains Florida Limestone rocks embedded, ranging from 4 inches to 8 inches

Footprint is a 130" X 130" X 130" triangle = 51 Sq. Ft.

1. Two panels of the three-sided structure contains 5 windows & 1 panel has 4 for a total of 14, ranging from 60 to 380 square inches

2. Reef has 48" requirement for turtle escape. Opening is also large enough for easy diver ingress.



Florida Limestone Reef

MODULE SPECIFICATIONS:

3. Each reef has 373 sq. feet of surface area outside
4. Each reef has a total of 577 sq. feet of surface area
5. Each reef has 176 cubic feet of volume.
6. All reefs will cure at least fourteen days before deployment
7. These units have demonstrated good stability during storm events over many years without settling, scouring, turning over or moving. **See attached letter from "Fish Haven Services"**
8. Deployed 75 units MBARA - 2007
9. Deployed 16 units Escambia Co. 2007
10. Deployed 225 units State of Mississippi - 2007
11. Deployed 365 units State of Alabama -2007



Florida Limestone Reef

MODULE SPECIFICATIONS:

12. All the above units have preformed as advertised with no scouring or settling. See attached documentation “**Fish Haven Services**”

13. Designed for 100+ year life cycle. Of thousands built since 2006, we never had a structural failure.

15. Reefs are designed with anti-scouring device. See attached documentation. (See **Figure 7**)



EXCEEDS REQUIREMENT FOR TURTLE ESCAPE



LIFTING & DEPLOYMENT IS DONE WITH REMOVALABLE LIFTING STRAPS



TAPERED WIDE FOOT PREVENTS SCOURING & SETTLING



2. Price



35 Florida limestone reefs =
\$70,000

3. Available Deployment Resources

Walter Marine's Yard Located at 22605 Andrews Lane, Orange Beach, AL



Available Deployment Resources:

1. Walter Marine owns 521 ft. of waterfront on the Intracoastal canal at 22505 Andrews Lane, Orange Beach, AL.

2. Facility & reef modules are available for inspection at any time.

3. Vessel Specifications:

MARANATHA II:

- 170' X 39' Offshore supply vessel refitted in 2017 for deploying artificial reefs.
- Dry-dock: February 2020.
- 3000 hp twin engine.
- Kongsberg Dynamic Positioning System able to hold position while deploying
- 85-ton crane
- Survey Grade GPS unit mounted to crane boom for recording deployment coordinates.
- 2 Furuno Radars
- Nobeltec Electronic Charting – Linked to ComNav AIS Collision Avoidance
- Kongsberg Auto Pilot
- Kongsberg weather Station



Deployment Capability: M/V MARANATHA II Dynamic Positioning

Kongsberg computers take control of the vessel's main engines and bow thruster and using GPS, hold the vessel within 3 meters of the desired location and within 1 degree of heading

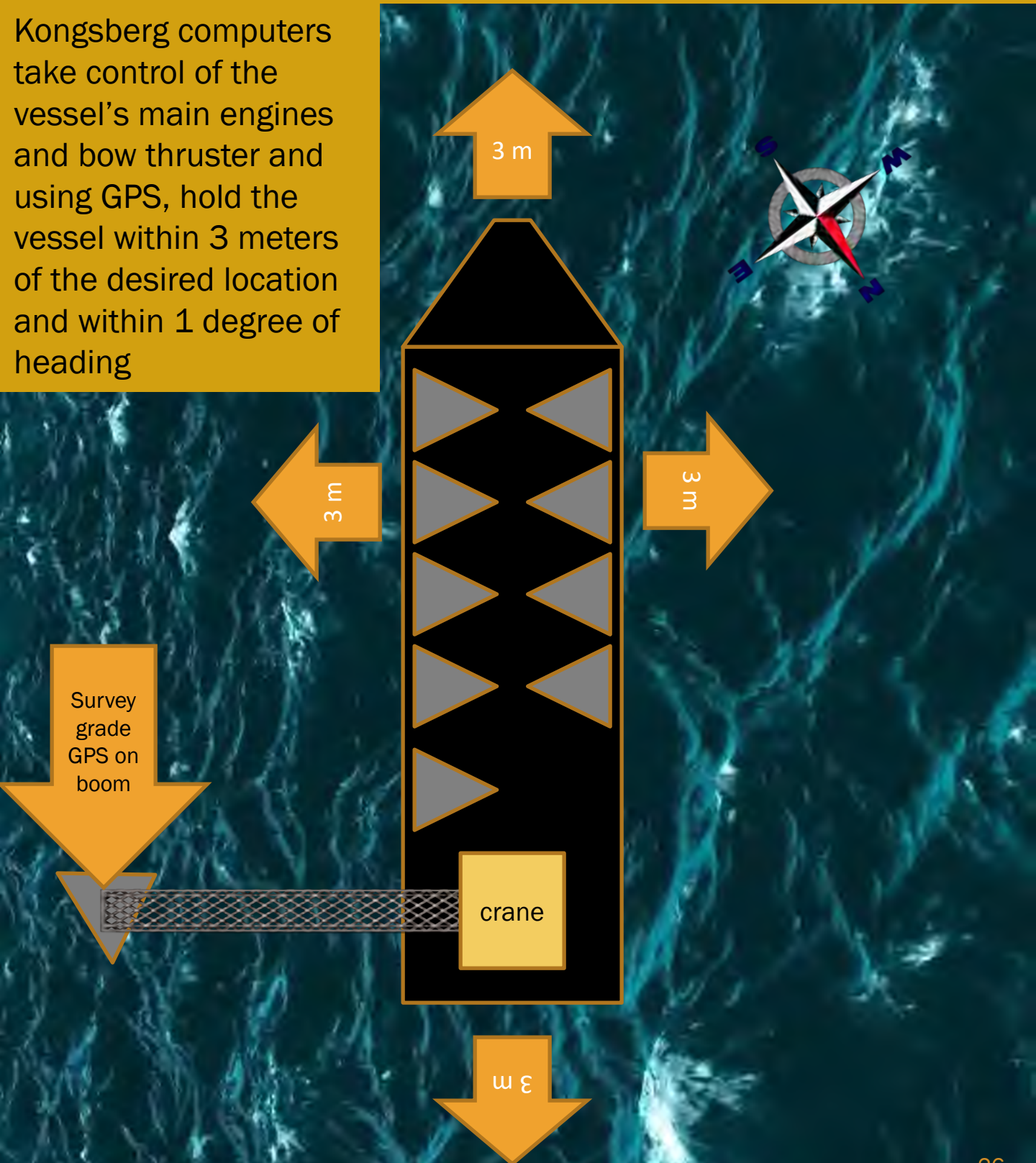

Available Deployment Resources:

- FCV 1220L Furno Sounder
- 200 KHZ Processor
- Remote mounted thermal imaging camera
- 12 Knots
- 250 KW generator capacity
- 2400 sq. feet of deck space
- 350 tons deck-load capacity
- 13,000 gallons potable water
- 25,000 gallons fuel

4. Our equipment & vessels are properly licensed, certified and approved as required for this project. Land operated equipment to include, but not limited to:

A. Two (2) 10K tele-handler forklifts.

B. One (1) 10K Case front loader forklift.

C. Two (2) 20-ton rough terrain cranes

D. One (1) 65-ton Grove rough terrain crane



Available Deployment Resources:

E. One (1) International front-end loader

F. Four (4) Welding machines

Other Floating Equipment:

A. 170' X 39' X 3' draft spud barge w/110-ton Lima crane

B. M/V MARANATHA 114' X 30' X 5.5' draft w/20-ton crane

5. Specialized Equipment:

A. Other equipment may include specialized equipment for loading and deploying the reefs.

6. Walter Marine owns all the equipment needed for the manufacture and deployment.

7. No subcontractors are used.

8. All equipment and personnel are available for this project.



4. Task Plan

Deployment Plan

Work Force

1. We have a work force of 12. Some wear more than one hat. Most are highly skilled with many years associated with Walter Marine. Department heads include: Concrete Foreman, Machinist, Welders, Fabrication, R & D, Mechanic, USCG Captains, Mate, Engineer, Deck Hand, Machine Operator and several general helpers.
2. However, our company is small and micro-managed by David & Stewart Walter that oversee and check each phase of operation and serve as quality control officers, environmental protection officers and safety officers.

Manufacture

1. Walter Marine has numerous concrete molds, jigs, welding facilities, and equipment to manufacture the requested modules.
2. The reef units are manufactured and stored near the bulkhead for loading onto the desired vessel.



Deployment Plan

Loading/transport

1. Walter Marine will consult with Franklin County Beach officials concerning a suitable day to inspect.
2. Walter Marine will fill out and submit the Cargo Manifest to the owner 14 days prior to loading.
3. The vessel will lift, via crane, the reefs from the shoreline onto the vessel and secure for transport.
4. Vessels are fitted with wooded decks to cushion and prevent movement.
5. MARANATHA II is capable of transporting 12 Super Reefs, or 120 Florida Limestone, or 43 Grouper Reefs or combinations for deployment at a time.
7. After the vessel is loaded, the QC inspector will check for damaged units and order replacements if found. The safety inspector will come after that and check for stability and security of the material on deck.
8. A suitable day will be chosen in coordination with Franklin County officials
9. Walter Marine will provide an air-conditioned stateroom, food and comfortable arrangements for an observer.



Deployment Plan

Deployment

1. The actual setting of the reef modules will be arranged carefully with Franklin County Beach officials, (buoys, small vessels, positions, communications, etc.)
2. If required a buoy will be placed at each individual reef site.
3. The vessel will maneuver next to the coordinates using Dynamic Positioning. This is a computer program that holds the vessel's position and heading within 3 meters.
4. Corrections to the vessel's position will be coordinated via radio between the crane operator and the captain.
5. The crane operator will place each reef on the coordinates as directed by the computer operator in the wheelhouse using the GPS unit on the cranes boom.
6. Reef locations will be recorded on the GPS computer program.
7. Coordinates will be delivered to Franklin County Beach.



Deployment Capability:

Permits, Licenses, etc.

All of Walter Marine's vessels and personnel are properly licensed and/or approved for all artificial reef deployment operations.

Florida does not require a contractor license for artificial reefs. Walter Marine has a properly licensed branch office in Davie, FL (enclosed) and is properly registered with the State of Florida, Department of State (enclosed) to do business in Florida.

Walter Marine will have onboard the latest NOAA Charts, Coast Guard Documentation, Latest copy of "Notice to Mariners", Corps Permit, Cargo Manifest and all other necessary documentation for operation inland and offshore for the purposes of building artificial reefs.

One crewmember will be designated to watch for turtles or manatees and suspend operations should any be sighted.



5. Schedule of Construction Operations

Schedule of Operation:

1. Total estimated days of manufacturing, loading, travel & deployment is 90 working days.
2. Estimated number of separate trips is 1.
3. Loading will take a total of 3 days .
4. Transit = 19 hours.
5. Days at sea = 1.
6. MARANATHA II is capable of transporting up to 12 Super Reefs, 120 Florida Limestone & 43 Grouper Reefs or combinations for deployment at a time.
7. Estimated date of completion is within 90 days.



Route



Transit Time:

Loading Site to Pensacola Pass 3.0 hours

Pensacola Pass to Deployment site 16 hours

TOTAL TRANSIT TIME = 19 hours

6. Experience and Understanding

FISH HAVEN SERVICES



MARINE REEF CONSULTING

7/1/2016

To whom it may concern:

My name is Bill Horn. I am a retired, Marine Fisheries Biologist IV who worked for 21 years with the Florida artificial reef program, which is currently under the Division of Marine Fisheries Management within the Florida Fish and Wildlife Conservation Commission. During those years, I managed many artificial reef funding contract agreements with local governments, who in turn have contracted through a competitive contracting process, with Walter Marine for the deployment of many types of prefabricated concrete, rock and steel artificial reef units.

The Florida Limestone Reef unit constructed and deployed by Walter Marine is the one of most commonly used reef units in the state. Local governments and others in Florida have constructed at least 198 patch reefs consisting of a total of 555 Florida Limestone Reef units off Florida since April 25, 2006 (FWC Public Reef Deployment database-10/30/2014). As contract manger, I was on site for many of these reef deployment operations without incident.

I have personally performed 14 scientific dive assessments on these types of reef units around Florida and have not observed any structural failure of these reef units on the bottom. Overall, I have observed a total of 34 species of fish on these units in Florida, including recreationally important species like red snapper, gag grouper, gray triggerfish, vermilion snapper, and greater amberjack.

During three days in July and August of 2015, I observed the deployment of 58 piling mounted snorkel reefs on behalf of Walton County, off Grayton Beach, Florida in 12 to 20 feet of water. The reef deployments were completed successfully and very professionally, with no problems and extremely good accuracy for a very complex artificial reef shaped like a turtle from above. A dive assessment the day after the first deployments showed all reef units upright, functioning well as artificial reefs.

I have found the Florida Limestone Reef and the piling mounted snorkel reef units unit to be very stable, very durable and perform very well as valuable habitat for many marine reef fish species. Based on my experience I feel these artificial reef units are unique in the way they are constructed, their design and overall characteristics. I feel they perform exceedingly well in providing long term habitat for marine fish and invertebrates. Contact me at the phone number and address below if you have any additional questions from me about these reef units.

SINCERELY,

WILLIAM HORN
FISH HAVEN SERVICES, LLC
3216 LAKESHORE DRIVE
TALLAHASSEE, FLORIDA 32312
850-566-6176

June 7, 2016

SUBJECT: Historical Observations of Walter Marine Modules and Company Performance

To whom it may concern:

My name is Jon W. Dodrill. I formally retired December 31, 2015 after 33 years of service with the state of Florida working as a biologist for the Florida Department of Natural Resources which later became the Department of Environmental Protection (DEP). In 1994 as an Environmental Administrator, I assumed responsibility for Florida's State Artificial Reef Program which functioned in part to provide federal Sport Fish Restoration dollars and state saltwater fishing license revenue funding in the form of competitive grants to local coastal governments, qualified 501(c)(3) nonprofit organizations, and state universities. The grant funding was utilized for the purpose of constructing and monitoring artificial reefs in Florida's Gulf and Atlantic coast state and adjacent coastal federal waters to provide fishing and diving locations as well as enhancing hard bottom habitat. In 1999 this highly successful and popular state artificial reef program which originated in 1980 as a close working partnership between the state and local coastal governments moved to the constitutionally created Florida Fish and Wildlife Conservation Commission. I continued work there until my retirement in the Division of Marine Fisheries Management as a Biological Administrator, continuing to manage the State's Artificial Reef Program with the assistance of two Marine Fisheries Biologist IVs, long time employees who also served as artificial reef project contract managers. Over the years we administered hundreds of individual reef contracts for artificial reef construction ranging from \$25,000 to \$1,000,000 with larger artificial reef contracts currently pending through the British Petroleum funded Deepwater Horizon Oil Spill Natural Resource Damage Assessment program.

Walter Marine:

I have professionally known Mr. David Walter of Walter Marine, Orange Beach Alabama, for at least fifteen years. Mr. Walter was one of the marine contractors who played a key role in assisting the state of Florida and its local coastal governments through the design and development of high quality artificial reef modules such as the concrete, rock and steel Florida Limestone Tetrahedron Reef unit. Hundreds of these units have been accurately placed off Florida alone as well as off other coastal states like Alabama. This Florida Limestone Reef design as well as others produced by Walter Marine that focused on fisheries habitat requirements, stability, durability and were environmentally friendly provided a critical alternative to some of the lesser quality materials of opportunity historically used early on in artificial reef construction. Walter Marine helped the state make an important transition away from light weight artificial reef materials of opportunity such as thin gauge metal materials, fiberglass objects, plastics, rubber, and other materials no longer considered to be environmentally friendly or not having the stability or durability to remain intact and in place or able to resist substantial burial at the depth placed during a hurricane event.

Mr. Walter is sensitive to the needs of the state artificial reef program, county reef managers, recreational fishers and divers as well as environmental requirements. He has designed and modified his modules over the years to meet these needs while both noting reef fish and benthic organism habitat requirements, stability and durability considerations and taking into account research results from artificial reef ecological studies.

In the ten years that the Walter Florida Limestone Reef modules have been in place in Florida, I have personally neither observed nor heard of structural failure of these units. Although no major hurricane has made landfall in Florida since 2006 (as of 2015), hurricanes and tropical storms have passed offshore in the Gulf and have generated seas up to 20 feet in the vicinity of some of the offshore Florida Limestone modules deployed at a depth of 90-130 feet. These Florida Limestone Reef modules remained intact and in place at the depth placed.

From my personal experience in interactions with Mr. Walter, his son Captain Stewart Walter and other Walter Marine vessel crew and construction personnel, Walter Marine is a highly professional company with the expertise, material resources, and a work ethic that consistently accomplishes artificial reef construction projects in a timely manner and to the satisfaction of both the state artificial reef program providing the funding and to the local coastal governments hiring the contractors. —Jon W. Dodrill, 247 Meridianna Drive, Tallahassee, FL 32312; cell ph. 850.766.7679.

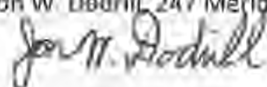



DEVELOPMENT SERVICES DEPARTMENT
PLANNING AND ZONING DIVISION
840 West 11th Street, Room 2350
Panama City, FL 32401
Phone: (850) 248-8250
Fax: (850) 248-8267

BOARD OF COUNTY
COMMISSIONERS

www.baycountyfl.gov

November 4, 2014

To whom it may concern,

POST OFFICE BOX 1818
PANAMA CITY, FL 32402

COMMISSIONERS:

MIKE NELSON
DISTRICT I

GEORGE B. GAINER
DISTRICT II

WILLIAM T. DOZIER
DISTRICT III

GUY M. TUNNELL
DISTRICT IV

MIKE THOMAS
DISTRICT V

EDWIN L. SMITH
COUNTY MANAGER

The County Commissioners of Bay County, Florida have purchased Walter Marine's limestone reefs for artificial reef construction projects. Over the years a program has been developed that requires the permitting of selected materials deployed in local waters. The artificial reef coordinator will oversee proposals and recommend the purchase of manufactured artificial reef modules such as Walter Marine's limestone reefs that fulfill the required specifications.

Walter Marine has designed and developed a unique and superior artificial reef module. See picture attached. The wide base and weight of the structure provides structure stability for many years. This increases the project life and creates an underwater landmark for marine organisms. The limestone imbedded in the concrete is ideal for plants and animals to attach. The limestone is softer than concrete and therefore allows boring organisms to colonize faster. The artificial reef develops in months and becomes productive quickly.

Monitoring and producing dive surveys on the Walter Marine limestone reefs have documented and guaranteed a return on the investment. The successful projects have confirmed the artificial reef modules provide essential marine life habitat.

In planning projects we also look at the way Artificial Reefs are fabricated and deployed. Walter Marine has a custom built deployment vessel named the Maranatha. This vessel is equipped with a crane that will rotate 360 degrees and can load and deploy reefs in an identified location. Stacking artificial reefs on board increases the number of modules per load and therefore reduces project costs.

The three items mentioned in this letter that is only found with the Walter Marine limestone reef are; the limestone imbedded in the concrete, the stackable pyramid size and shape with a large base for stability, the custom built Maranatha designed specifically to deploy more stackable artificial reef modules per load.



**BOARD OF COUNTY
COMMISSIONERS**

www.baycountyfl.gov

POST OFFICE BOX 1818
PANAMA CITY, FL 32402

COMMISSIONERS:

MIKE NELSON
DISTRICT I

GEORGE B. GAINER
DISTRICT II

WILLIAM T. DOZIER
DISTRICT III

GUY M. TUNNELL
DISTRICT IV

MIKE THOMAS
DISTRICT V

EDWIN L. SMITH
COUNTY MANAGER

Walter Marine is the leader in the Artificial Reef Industry. The Walter Marine limestone reef is the "State of the Art", Their project evaluation scores are higher than other manufactures and dominate the field of bid proposals. This unique artificial reef module design and deployment is better than the rest. The successful projects in Bay County, Florida have earned support for this positive recommendation.

Sincerely,

Allen Golden, P.E.
Florida P.E. Lic. No. 66287
Alabama P.E. Lic. No. 25079
Artificial Reef Coordinator
Development Review Engineer
Planning and Zoning Division
840 W. 11th Street Room 2350
Panama City, FL 32401
E-Mail: agolden@baycountyfl.gov
Office: (850) 248-8250
Fax: (850) 248-8267



Robert J. Bentley
GOVERNOR

N. Gunter Guy, Jr.
COMMISSIONER

STATE OF ALABAMA
DEPARTMENT OF CONSERVATION AND NATURAL RESOURCES
MARINE RESOURCES DIVISION
POST OFFICE DRAWER 458
GULF SHORES, ALABAMA 36547
TEL (251) 968-7576
FAX (251) 968-7307
amrds@gulfnet.com

Our mission is to manage the State's marine fishery resources through research, enforcement, and education for the maximum benefit of the resources and the citizens of Alabama.



Christopher M. Blankenship
Acting Director
MARINE RESOURCES DIVISION

11 April 2011

To whom it may concern,

Mr. David Walter of Reefmaker, Inc. has been awarded several contracts from the Department of Conservation and Natural Resources / Marine Resources Division to construct and deploy artificial reef structures in the Gulf of Mexico to serve as public fishing reefs. Mr. Walter and his staff professionally completed the job tasks outlined in these contracts providing a quality product in a timely manner. If Mr. Walter were to submit a bid for any future projects it would be received without any misgivings.

If you require additional information please feel free to contact me.

Sincerely,

Kevin Anson
Chief Biologist



WWW.MBARA.ORG

4 Nov 2014

*FROM: Mexico Beach Artificial Reef Association, Inc.
P.O. Box 13006
Mexico Beach, FL 32410-3006*

SUBJECT: Walter Marine Artificial Reef Products

To who it may concern,

My name is Robert L. Cox and I am the President of the Mexico Beach Artificial Reef Association in Mexico Beach, Florida. I have been managing our artificial reef program since 2009 and I plan artificial reef construction projects for the City of Mexico Beach and obtain funding for the projects. I'm also a research diver monitoring the condition and performance of our artificial reefs built by various manufactures in the Gulf of Mexico in permitted sites off the coast of Mexico Beach, FL.

Over the past 12 years, I've been involved with the planning and monitoring of our artificial reefs. When Walter Marine introduced their Florida Limestone Artificial Reef, we became interested and purchased their products because we believed they best emulated the components of natural reefs that consist of limestone substrates. We also learned from studies conducted by marine biologists that limestone is a better substrate because it's favorably softer than concrete and the PH of the limestone is better suited for the establishment and growth of marine organisms. Additionally, our reef monitoring program observations show that artificial reefs embedded with limestone are better at promoting natural marine growth over artificial reefs without embedded limestone. Therefore, over the past 5 years we have made the use of embedded limestone a standard requirement in all our artificial reef construction contracts. As a result, we have consistently selected and awarded our contracts to Walter Marine because no other artificial reef manufacturer has been able to meet our requirements for embedded limestone on the exterior of artificial reef structure surfaces.

I would recommend Walter Marine's limestone reefs to anyone that seeks to promote highly productive artificial reefs comparable to the natural limestone reefs. I am available to answer any questions you may have about these reefs.

A handwritten signature in black ink, appearing to read 'Robert L. Cox', is written over a light blue horizontal line.

*Robert L. Cox, President
Mexico Beach Artificial Reef Association*



STATE OF ALABAMA
DEPARTMENT OF CONSERVATION AND NATURAL RESOURCES

64 NORTH UNION STREET, SUITE 479
MONTGOMERY, ALABAMA 36130
(334) 242-3476
FAX (334) 242-0289
www.outdooralabama.com

October 29, 2014

ROBERT BENTLEY
GOVERNOR

N. GUNTER GUY, JR.
COMMISSIONER

CURTIS JONES
DEPUTY COMMISSIONER

TERRY N. BOYD, CHIEF
ENGINEERING SECTION

To whom it may concern,

My name is Terry N. Boyd and I am the Chief Engineer for the Alabama Department of Conservation & Natural Resources. I make all decisions along with our Marine Biologist for the State of Alabama regarding selecting artificial reefs for deployment in state controlled water ways and bodies of water.

I have in the past, in my official capacity, selected Walter Marine's limestone reefs (photo of which is attached as Exhibit A) for deployment in the Gulf of Mexico, under State of Alabama construction contracts. The reason we selected the Walter Marine limestone reefs is because of the unique construction of the reefs and how they attract fish. Specifically, we selected the Walter Marine limestone reefs because they are constructed of a sturdy base, with a large footprint. Strong concrete frame disposed on the base, concrete walls disposed on the frame and including limestone embedded in the walls. The walls disposed on the base provide a hollow interior that attracts fish and other marine life. The limestone in the walls protrude from the walls and provide ample area for boring marine life to bore into. All of these characteristics provide an artificial reef that attracts fish and fulfills our mission – promoting marine life.

I would recommend Walter Marine's limestone reefs to anyone that seeks to promote marine life. I am available to answer any questions you may have about these reefs.

Sincerely,

Handwritten signature of Terry N. Boyd in black ink.

Terry N. Boyd, PE, PLS
Chief of Engineering



References/Qualifications:

Walter Marine

Patent holder No. 6,042,300 Artificial Reef.

Patent holder No. 6,824,327 B1 Artificial Reef

Patent holder No. 7,513,711 Artificial Marine Reef

Inducement Patent holder No. 7,827,937 Marine Line Form

Habitat Patent holder No. 9,339,017 B1 Living Wave Barrier

David Walter D/B/A Walter Marine was founded in 1968. It has remained in the same hands as a sole proprietorship repairing vessels and owning and operating a shipyard until 1986. In 1986 Walter Marine became the first commercial artificial reef builder in the State of Alabama. By the year 2021 Walter Marine had deployed over 51,000 artificial reefs and today is the largest deployer of artificial reefs in the United States. It holds five patents for artificial reefs. In addition, Walter Marine has prepared and deployed 24 ships in the Gulf of Mexico.

Executive Summary:

Walter Marine deployed materials of opportunity until 1996. In 1996 Walter Marine began designing and manufacturing artificial reefs. The majority were undocumented private reefs in the State of Alabama and Florida Panhandle. Included below is a list of documented public reefs.

Previous Experience:

1990

Escambia County, Florida:

May 29, 1990 completion date/on time

Funding - State of Florida

Contract with Escambia County Florida for the donation, preparation, cleaning, delivery and sinking of a tugboat "Sylvia" cleaning. This vessel was purchased cleaned, prepared and deployed by Walter Marine.

Robert Turpin Escambia County Reef Coordinator robert_turpin@co.escambia.fl.us for 2003 contracts (850) 595-4395. Eileen Beard Escambia County Recreational board member since 1988 (850) 433-4319.

\$25,000

Escambia County, Florida:

June 15, 1990 completion date/on time

Funding - State of Florida

Purchase Order #09100. Contract with Escambia County Florida for turnkey project.

“Furnishing, cleaning (to all required agency specifications-Coast Guard, U. S. Army Corps of Engineers, Florida Department of Environmental Regulation, and Florida Department of Natural Resources) one LCM donated by Gulf Islands National Seashore and one 56’ Tugboat “Heron””. The LCM donated by Gulf Islands National Seashore was sunk at their dock.

Walter Marine raised the vessel without incident and towed it its facility. The Heron was located at Radcliff Material in Mobile, Alabama. It was purchased by Walter Marine, raised and towed to Walter Marine’s facility. Both vessels were cleaned, prepared and deployed by Walter Marine.

Robert Turpin Escambia County Reef Coordinator, (robert_turpin@co.escambia.fl.us) for 2003 contracts (850) 595-4395. Eileen Beard Escambia County Recreational board member since 1988 (850) 433-4319.

\$30,000

Escambia County, Florida:

1990

Funding - State of Florida

Contract with Escambia County, Florida for the preparation and deployment of the Tugboat “Phillip” (to all required agency specifications-Coast Guard, U. S. Army Corps of Engineers, Florida Department of Environmental Regulation, and Florida Department of Natural Resources). This vessel was purchased cleaned, prepared and deployed by Walter Marine.

Robert Turpin Escambia County Reef Coordinator (robert_turpin@co.escambia.fl.us)for 2003 contracts (850) 595-4395. Eileen Beard Escambia County Recreational board member since 1988 (850) 433-4319.

\$25,000

State of Alabama

1990

Contract with Alabama Department of Conservation for the preparation and deployment of a US Coast Guard buoy tender. Tender was towed from Mobile, AL Coast Guard Base and cleaned to all required agency specifications-Coast Guard, U. S. Army Corps of Engineers, Florida Department of Environmental Regulation, and Florida Department of Natural Resources) and deployed without incident. This vessel was deployed by Walter Marine.

Contact: Craig Newton (Craig.Newton@dcnr.alabama.gov) Kevin Anson (Kevin.Anon@dcnr.alabama.gov) 251-968-7576, Alabama Department of Conservation, P. O. Drawer 458, Gulf Shores, AL 36547

Payment in form of material/equipment removed from vessel

\$- Records lost in flood

1991

Escambia County, Florida:

January 1, 1991 completion date/on time

Funding - State of Florida

Purchase Order #03961. Contract with Escambia County Florida for turnkey project for deployment of tugboat "Born Again" and a FAA tower (to all required agency specifications-Coast Guard, U. S. Army Corps of Engineers, Florida Department of Environmental Regulation, and Florida Department of Natural Resources). This vessel was purchased cleaned, prepared and deployed by Walter.

Robert Turpin Escambia County Reef Coordinator (robert_turpin@co.escambia.fl.us) for 2003 contracts (850) 595-4395. Eileen Beard Escambia County Recreational board member since 1988 (850) 433-4319.

\$25,000

Escambia County, Florida:

May 16, 1991 completion date/on time

Funding - State of Florida

Purchase Order #06358. Contract with Escambia County Florida for preparation, transportation and deployment of the dredge "Avocet" (to all required agency specifications-Coast Guard, U. S. Army Corps of Engineers, Florida Department of Environmental Regulation, and Florida Department of Natural Resources). This vessel was purchased cleaned, prepared and deployed by Walter Marine.

Robert Turpin Escambia County Reef Coordinator (robert_turpin@co.escambia.fl.us) for 2003 contracts (850) 595-4395. Eileen Beard Escambia County Recreational board member since 1988 (850) 433-4319.

\$55,000

1993

Escambia County, Florida:

April 23, 1993 completion date/on time

Funding - State of Florida

Purchase Order #5305. Contract with Escambia County Florida for the design, Manufacture, transportation, deployment and study of 12 experimental reef modules.

Deployed on time and regular dive reports were issued for 3 years.

Robert Turpin Escambia County Reef Coordinator (robert_turpin@co.escambia.fl.us) for 2003 contracts (850) 595-4395. Eileen Beard Escambia County Recreational board member since 1988 (850) 433-4319.

\$1,500

Escambia County, Florida:

1993

Funding - State of Florida

Purchased, cleaned & deployed 180' ship "Pete Tide"

Robert Turpin Escambia County Reef Coordinator (robert_turpin@co.escambia.fl.us) for 2003 contracts (850) 595-4395. Eileen Beard Escambia County Recreational board member since 1988 (850) 433-4319.
\$55,000

1995

U. S. Coast Guard:

June 1995 completion date/on time

Funding - United States Coast Guard

Contract #DTCG84-95-R-HYU469. Walter Marine worked as a subcontractor under Oil Recovery Company for the preparation, cleaning and deployment of a 3,000 ton vessel "Antares". This is one of the largest vessels deployed as an artificial reef in the Gulf of Mexico. This vessel was cleaned, prepared and deployed by Walter Marine.

Contact: Oil Recovery Company President Paul 251-432-4223

\$50,000

1999

U. S. Navy:

May 17, 1999 completion date/on time

Funding - United States Navy

Purchase Order #N61331-99-M-1860 and N61331-99-M-1862. Towing and disposal of two Navy Ships YDT-14 & YDT-15, Navy Base - Coastsysta Dahlgren in Panama City, Florida. Cleaned, prepared and deployed vessels in Escambia County's reef site.

Ed Delanoy at the Craft Office 850-234-5230 or Mr. Art Ducette, NDSTC Code 09, Naval Diving and Salvage Training Center, 350 Craig Rd., Panama City, FL 32407-7016.

\$28,000 plus equipment and material removed from vessels

2001

Military Sealift Command N00031-01-C-1005

February 2001 completion date/on time

Walter Marine ferried two Naval vessels, 131 ft. YTB tugs from Virginia to Guantanamo Bay, Cuba

Achille Broennimann 202-685-5965

\$150,000

Military Sealift Command N00031-01-C-1005

July 2001 completion date/on time

Walter Marine ferried naval vessel "C-Note" from Virginia to Roosevelt Roads, Puerto Rica

Achille Broennimann 202-685-5965

\$31,000

U. S. Army Corps of Engineers:

November 13, 2001 completion date/on time
Evans-Hamilton, Inc. Purchase Order # 6000-28-11. Remove and replace a wave action POD located Gulf of Mexico near Alabama Point. This project is ongoing and Walter Marine has provided this service three times since 11-13-2001. Contact Larry G. Caviness U. S. Army Corps of Engineer Research & Development Center, Vicksburg, Mississippi, 601-634-2338 \$5,000

2002

Florida Fish & Wildlife Conservation Commission:

December 17, 2002 completion date/on time
FWC Contract #FWCC-02097. Designed, manufactured & deployed 227 artificial reefs as pictured below. Patent holder No. 6,824,327 B1 Artificial Reef Model: Florida Special "FSMR"
Contact: Keith Mille, Biological Administrator
Division of Marine Fisheries Management - Artificial Reef Program
Florida Fish and Wildlife Conservation Commission
620 South Meridian Street, Box 4B2
Tallahassee, FL 32399-1600
web: <http://myfwc.com/conservation/saltwater/artificial-reefs/>
office: (850) 617-9633
mobile: (850) 509-2974
fax: (850) 487-4847
email: keith.mille@myfwc.com
\$ Record destroyed in flood

2003

Bay County, FL

February 19, 2003 completion date/on time
Funding - State of Florida
Designed, manufactured & deployed
57 "Florida Specials"
Allen Golden
agolden@baycountyfl.gov
205-567-0173
\$ record destroyed in flood

Destin, Okaloosa County

March 24, 2003 completion date/on time
Funding - State of Florida
Designed, manufactured & deployed
56 "Florida Special" reefs
Contact Cindy Halsey, Board of County Commissioners

602C North Pearl St., Crestview, FL 32536 850-651-7394
\$ record destroyed in flood

Escambia County, Florida:

May 12, 2003 completion date/on time

Funding - State of Florida

Purchase Order #231562-1. Contract with Escambia County, Florida for the design, manufacture & deployment of 113 "Florida Special" artificial reefs.

Contact: Trey Goodman at the Parks and Recreation Department of Escambia for projects from 1990 to 1993. Robert Turpin Escambia County Reef Coordinator

(robert_turpin@co.escambia.fl.us) for 2003 contracts (850) 595-4395. Eileen Beard

Escambia County Recreational board member since 1988 (850) 433-4319.

\$ record destroyed in flood

Taylor County, Florida

2002 & 2003 completion date/on time

Sub-contacted to ARI. Precision deployment of ARI reef units. Contact Clay Olsen at (850) 838-3508.

\$ record destroyed in flood

Organization for Artificial Reefs (OAR):

2003 Contracted to ARI. Precision deployment of ARI reef units. Contact Alan Richardson - (grouperboy@yahoo.comOAR)

2545 Blairstone Pines Drive Tallahassee, FL 32301

at (850) 656-2114.

\$ record destroyed in flood

2004

Destin, Okaloosa County, Florida

June 8, 2004 completion date/on time

Designed, manufactured & deployed

60 "Florida Special" reefs

Contact Cindy Halsey, Board of County Commissioners

602C North Pearl St., Crestview, FL 32536 850-651-7394

\$ record destroyed in flood

2005

Martin County, Florida

June, 2005 completion date/on time

Funding - State of Florida

Designed, manufactured & deployed

60 "Florida Specials. Contact: Kathy

Fitzpatrick, PE, Coastal Engineer, Martin County Engineering Department

2401 SE Monterey Rd., Stuart, FL 34996
\$ record destroyed in flood

Mexico Beach, FL

January 11, 2005 completion date/on time
Designed, manufactured & deployed
33 "Florida Special" reefs
Contact Robert Cox
rcox@mchsi.com
WWW.MBARA.ORG
\$ record destroyed in flood

Okaloosa County, Florida

June 2005 completion date/on time
Funding - State of Florida \$100,000 project
Okaloosa County Reef development Project 2004, "Starfish Artificial Reef"
Designed, manufactured & deployed 120 "Florida Special" artificial reefs
Contact Cindy Halsey, Board of County Commissioners
602C North Pearl St., Crestview, FL 32536 850-651-7394
\$ record destroyed in flood

2006

Escambia County, Florida

June 2006 completion date/on time
Funding - State of Florida
Contract # PD05-06.064
Designed, manufactured & deployed 20 "Florida Special" reefs. Contact Robert Turpin
Escambia County Reef Coordinator (robert_turpin@co.escambia.fl.us) 850-595-4395
\$ record destroyed in flood

State of Alabama

2004 – 2006 completion date/on time
Designed, manufactured & deployed 460 "Florida Specials". Contact: Craig Newton
(Craig.Newton@dcnr.alabama.gov) or Kevin Anson (Kevin.Anson@dcnr.alabama.gov)
251-968-7576, Alabama Department of Conservation, P. O. Drawer 458, Gulf Shores, AL
36547
\$ record destroyed in flood

Santa Rosa County, Florida

June 2006 completion date/on time
Funding - State of Florida
Designed, manufactured & deployed
30 "Florida Limestone" reefs
Contact Contact: Keith Mille, Biological Administrator
Division of Marine Fisheries Management - Artificial Reef Program

Florida Fish and Wildlife Conservation Commission
620 South Meridian Street, Box 4B2
Tallahassee, FL 32399-1600
web: <http://myfwc.com/conservation/saltwater/artificial-reefs/>
office: (850) 617-9633
mobile: (850) 509-2974
fax: (850) 487-4847
email: keith.mille@myfwc.com
\$ record destroyed in flood

City of Destin, Florida

June 2006 completion date/on time
Funding - State of Florida
RFP # P06-01A "Barnacle" Artificial Reef Project
Designed, manufactured & deployed 30 "Florida Special" reefs Contact Cindy Halsey 850-651-7394 or Scott 850-978-0009
\$ record destroyed in flood

Okaloosa County, Florida

September 2006 completion date/on time
Funding - State of Florida
Purchased, cleaned & deployed 129' Tugboat
Contact Cindy Halsey 850-651-7394 or Scott 850-978-0009
\$ record destroyed in flood

2007

Mexico Artificial Reef Program

2007 completion date/on time
Funding - State of Florida
Designed, manufactured & deployed 75 Florida Limestone reef units
Mexico Artificial Reef Association
Contact Robert L. Cox Jr
rcox@mchsi.com
WWW.MBARA.ORG
\$ record destroyed in flood

Escambia County, Florida

April 2007 completion date/on time
Funding - State of Florida
Deployed approx. 200 tons of pipe + designed, manufactured & deployed 16 Florida Limestone reef units
Contact Robert Turpin Escambia County Reef Coordinator
(robert_turpin@co.escambia.fl.us) 850-595-4395
\$ - record destroyed in flood

State of Mississippi

July, 2007 completion date/on time

Designed, manufactured & deployed 240 reef units (15 Florida Specials & 225 Florida Limestone)

Contact: James Sanders - (James.Sanders@dmr.ms.gov) Artificial Reef Bureau Director | Office of Marine Fisheries Mississippi Department of Marine Resources | dmr.ms.gov
1141 Bayview Avenue | Biloxi, MS 39530 Office: 228-523-4089

§ - record destroyed in flood

State of Alabama

2007 completion date/on time

Designed, manufactured & deployed (50 Florida Specials & 365 Florida Limestone)

Contact Craig Newton (Craig.Newton@dcnr.alabama.gov) or Kevin Anson (Kevin.Anon@dcnr.alabama.gov) 251-968-7576, Alabama Department of Conservation, P. O. Drawer 458, Gulf Shores, AL 36547

§ - record destroyed in flood

State of Alabama

2007 completion date/on time

Designed, manufactured & deployed (40 Florida Specials & 20 Florida Limestone)

Contact Craig Newton (Craig.Newton@dcnr.alabama.gov) or Kevin Anson (Kevin.Anon@dcnr.alabama.gov) 251-968-7576, Alabama Department of Conservation, P. O. Drawer 458, Gulf Shores, AL 36547

§ - record destroyed in flood

Panama City, Bay County, FL - Organization of Artificial Reefs

2007 completion date/on time

Designed, manufactured & deployed

25 "Florida Limestone" reefs

Contact Alan Richardson - (grouperboy@yahoo.comOAR)

2545 Blairstone Pines Drive Tallahassee, FL 32301

at (850) 656-2114.

§ - record destroyed in flood

2008

State of Mississippi

2008 completion date/on time

Designed, manufactured & deployed 60 Florida Limestone reef units

Contact James Sanders - (James.Sanders@dmr.ms.gov) Artificial Reef Bureau Director | Office of Marine Fisheries Mississippi Department of Marine Resources | dmr.ms.gov 1141 Bayview Avenue | Biloxi, MS 39530

Office: 228-523-4089

§ - record destroyed in flood

Escambia County, Florida

2008 completion date/on time

Funding - State of Florida

Designed, manufactured & deployed

30 Florida Limestone reef units

Contact Robert Turpin Escambia County Reef Coordinator

(robert_turpin@co.escambia.fl.us) 850-595-4395

§ - record destroyed in flood

Mexico Beach Artificial Reef Association

2008 completion date/on time

Funding - State of Florida

Designed, manufactured & deployed

100+ Florida Special – Florida Limestone reef units

Robert L. Cox Jr

rcox@mchsi.com

WWW.MBARA.ORG

Mexico Beach Artificial Reef Association 850-819-2333

§ - record destroyed in flood

2009**State of Mississippi**

2009 completion date/on time

Purchased, cleaned and deployed 85' Shrimp boat

Contact James Sanders - (James.Sanders@dmr.ms.gov) Artificial Reef Bureau Director |

Office of Marine Fisheries Mississippi Department of Marine Resources | dmr.ms.gov 1141

Bayview Avenue | Biloxi, MS 39530 Office: 228-523-4089

Vessel was acquired by Walter Marine and cleaned to U.S. army Corps of Engineers/U.S.

Coast Guard specifications, towed to site in Gulf of Mexico and sunk. The vessel was anchored and sunk offshore from Biloxi, MS.

\$25,000

City of Mexico Beach

June 2009 completion date/on time

Funding - State of Florida

Designed, manufactured & deployed

29 Florida special & 26 Grouper reefs

Robert L. Cox Jr

rcox@mchsi.com

WWW.MBARA.ORG

Mexico Beach Artificial Reef Association 850-819-2333

§ - record destroyed in flood

Escambia County

June 2009 completion date/on time

Deployed residue of ARI reefs and designed, manufactured & deployed 3 Florida Limestone & 1 grouper reef

Contact Robert Turpin Escambia County Reef Coordinator
(robert_turpin@co.escambia.fl.us) 850-595-4395

\$ - record destroyed in flood

State of Alabama

June 2009 completion date/on time

Deployed 2 barge loads of concrete rubble from old Gulf State Park fishing pier

Contact Craig Newton (Craig.Newton@dcnr.alabama.gov) or Kevin Anson
(Kevin.Anson@dcnr.alabama.gov) 251-968-7576, Alabama Department of Conservation, P.

O. Drawer 458, Gulf Shores, AL 36547

\$ - record destroyed in flood

State of Alabama

July 2009 completion date/on time

Designed, manufactured & deployed

12 Florida Limestone reefs next to new Gulf State Park Fishing Pier

Contact Craig Newton (Craig.Newton@dcnr.alabama.gov) or Kevin Anson
(Kevin.Anson@dcnr.alabama.gov) 251-968-7576, Alabama Department of Conservation, P.

O. Drawer 458, Gulf Shores, AL 36547

\$ - record destroyed in flood

City of Gulf Breeze

September 1, 2009 completion date/on time

400 ft. EcoSystems Wave Barrier

Heather Reed

Project Manager

The City of Gulf Breeze Deadman's Island Restoration Project

Ecological Consulting Services Inc

38 S Blue Angel Pkwy #346

Pensacola, FL 32506

850-417-7008

850-346-2073

\$201,000

2010

State of Alabama project:

March, 2010 completion date/on time

Manufactured 546 Wave Attenuator Devices – 13,000 lbs ea. and delivered to Bayou
LaBatre, AL

J & W Marine Enterprises, Inc.

Wayne Eldridge, President 251-751-4127

\$546,000

Mexico Beach Artificial Reef Association

September 28, 2010 completion date/on time

Funding - State of Florida

Designed, manufactured & deployed

1 Florida special, 18 Florida limestone & 3 EcoSystems on pedestals

Robert L. Cox Jr

rcox@mchsi.com

WWW.MBARA.ORG

Mexico Beach Artificial Reef Association (850) 647-6169

§-Record destroyed in flood

2011

Organization of Artificial Reefs

May 3, 2011 completion date/on time

Designed, manufactured & deployed

15 Florida Special Artificial Reefs

Contact Alan Richardson - (grouperboy@yahoo.comOAR)

2545 Blairstone Pines Drive Tallahassee, FL 32301

at (850) 656-2114.

§-Record destroyed in flood

Mexico Beach Artificial Reef Association

May 5, 2011 completion date/on time

Funding - State of Florida

Designed, manufactured & deployed

22 Florida Limestone, 8 EcoSystems & 5 Grouper artificial reef units

Robert L. Cox Jr

rcox@mchsi.com

WWW.MBARA.ORG

Mexico Beach Artificial Reef Association (850) 647-6169

§-Record destroyed in flood

Florida Fish & Wildlife FWC 09/10-102

May 23, 2011 completion date/on time

Manufactured & deployed 1800 Artificial reefs. Designed and built a device to deploy 4 units at a time maintaining 6 inches clearance between.

Contact: Keith Mille, Biological Administrator

Division of Marine Fisheries Management - Artificial Reef Program

Florida Fish and Wildlife Conservation Commission

620 South Meridian Street, Box 4B2

Tallahassee, FL 32399-1600

web: <http://myfwc.com/conservation/saltwater/artificial-reefs/>

office: (850) 617-9633

mobile: (850) 509-2974

fax: (850) 487-4847

email: keith.mille@myfwc.com
Bill Lindberg - WJLindberg@mail.ifas.ufl.edu
352-392-9617 ext 239 & 352-871-5104
Funding - State of Florida \$508,333.00 .

City of Gulf Breeze, Florida

June, 2011 completion date/on time
Designed, manufactured & deployed
Deadman's Island EcoSystems Living Wave Barrier
Heather Reed
Project Manager
The City of Gulf Breeze Deadman's Island Restoration Project
Ecological Consulting Services Inc
38 S Blue Angel Parkway #346
Pensacola FL 32506
850-417-7008
850-346-2073 (cell preferred)
\$325,000

Texas Parks & Wildlife Department

Contract 802-11-13077
April 15, 2011 to August 31, 2011 completion date/on time
Designed, manufactured & deployed
200 "Florida Specials" & 200 "Florida Limestone" reef units offshore.
Dale Shively 512-389-4686
\$498,000

Escambia County, Florida

July, 2011 completion date/on time
Designed, manufactured and deployed
33 EcoSystems Snorkeling Reefs on Pensacola
Beach. Designed and built a special device to install the reefs on 20' pilings driven
Piling without the use of divers
Contact Robert Turpin (robert_turpin@co.escambia.fl.us) 850-595-4395
\$60,000

Okaloosa County

July 28, 2011 completion date/on time
Design, Manufacture and Deploy
32 Florida Limestone reefs
Scott Henson
shenson@co.okaloosa.fl.us
\$48,400

2012

Mexico Artificial Reef Association

April, 2012 completion date/on time
Funding - State of Florida
Designed, manufactured & deployed
31 Florida Limestone
10 EcoSystems
13 Grouper Reefs
Robert L. Cox Jr
rcox@mchsi.com
WWW.MBARA.ORG
\$-Destroyed in flood

Mexico Beach, FL

April 6, 2012 completion date/on time
Designed, manufactured & deployed
3 piling mounted EcoSystems
Robert L. Cox Jr
rcox@mchsi.com
WWW.MBARA.ORG
\$3,000

Santa Rosa County

May 21, 2012 & September 21, 2012 completion date/on time
Designed, manufactured & deployed
135 EcoSystem Snorkeling Reefs
Mark Griffith
mark.griffith.home@gmail.com
850.677.1875
\$199,995

Okaloosa County

August 7, 2012 completion date/on time
Funding - State of Florida
Designed, manufactured & deployed
40 Florida Limestone Reefs
Scott Henson
shenson@co.okaloosa.fl.us
850-978-0009
\$-Record destroyed in flood

Panama City, Bay County, FL

July 10, 2012 completion date/on time
Designed, manufactured & deployed
20 Florida Limestone, 10 Grouper reefs & 10 EcoSystems
units.
Allen Golden
agolden@baycountyfl.gov

205-567-0173
\$63,000

2013

Yellow River Marsh Preserve

March 2013 completion date/on time
Funding - State of Florida
Designed, manufactured & deployed
1000' EcoSystem Wave Attenuators
Earth Ethics 850-549-7472
\$349,275

Mexico Beach

April, 2013 completion date/on time
Funding - State of Florida
Designed, manufactured & deployed
10 EcoSystems Reefs
28 Florida Limestone
10 Grouper
Robert L. Cox Jr
rcox@mchsi.com
WWW.MBARA.ORG
\$79,950

Alabama Reef Foundation

June, 2013 completion date/on time
Purchased, cleaned and deployed 271 ship "The Lulu"
Vince Lucido, PE & PLS
Lucido Engineering and Surveying, LLC
24693 Canal Rd. Suite A
Orange Beach, AL 36561
251 967 3250 office
VinceLucido@Lucidoeng.com
\$500,000

Alabama Department of Conservation

July 2013 completion date/on time
Designed, manufactured & deployed
220 - 6' Florida Limestone reef units
34 - EcoSystems reef units mounted on pilings
Craig Newton (Craig.Newton@dcnr.alabama.gov) or Kevin Anson
(Kevin.Anson@dcnr.alabama.gov) 251-968-7576, Alabama Department of Conservation, P.
O. Drawer 458, Gulf Shores, AL 36547
\$374,000

State of Alabama

August 2013 completion date/on time

Designed, manufactured & deployed

30 Super reefs

Craig Newton (Craig.Newton@dcnr.alabama.gov) or Kevin Anson

(Kevin.Anon@dcnr.alabama.gov) 251-968-7576, Alabama Department of Conservation, P.

O. Drawer 458, Gulf Shores, AL 36547

\$402,000

State of Mississippi

September, 2013 completion date/on time

Designed, manufactured & deployed

50 Florida Limestone reefs.

James Sanders - (James.Sanders@dmr.ms.gov) Artificial Reef Bureau Director | Office of

Marine Fisheries Mississippi Department of Marine Resources | dmr.ms.gov 1141 Bayview

Avenue | Biloxi, MS 39530 Office: 228-523-4089

\$96,000

2014

Alabama Poseidon's Playground

January, 2014 completion date/on time

Walter Marine has an ongoing contract to deploy various structures in this area. It has included statues and 6 ft. versions of Florida Limestone with famous actors handprints.

Vince Lucido, PE & PLS

Lucido Engineering and Surveying, LLC

24693 Canal Rd. Suite A

Orange Beach, AL 36561

251 967 3250 office

VinceLucido@Lucidoeng.com

\$4,300

Escambia County

March 12, 2014 completion date/on time

Designed, manufactured & deployed

Snorkeling reef on Perdido Key

33 Reef units

Contact Robert Turpin 850-595-4395 (robert_turpin@co.escambia.fl.us)

\$60,000

City of Mexico Beach

April 2, 2014 completion date/on time

Funding - State of Florida

Designed, manufactured & deployed 15 Grouper/EcoSystems

33 Florida Limestone

10 Super reefs

Robert L. Cox Jr
rcox@mchsi.com
WWW.MBARA.ORG
\$60,000

MBARA

April 2, 2014 completion date/on time
Designed, manufactured & deployed
3 Florida Limestone
1 Grouper reef
Robert L. Cox Jr
rcox@mchsi.com
WWW.MBARA.ORG
\$3,400

Panama City, Bay County

June 10, 2014 completion date/on time
Designed, manufactured & deployed
18 Florida Limestone & 18 Grouper reefs
Allen Golden
agolden@baycountyfl.gov
205-567-0173
\$60,000

Panama City, Bay County

June 30, 2014 completion date/on time
Deployed two fighter jets
Allen Golden
agolden@baycountyfl.gov
205-567-0173
\$22,500

Organization for Artificial Reefs

June 20, 2014 completion date/on time
4 Florida Limestone
2 Super Reefs
4 Grouper reefs
Alan Richardson alan@talcor.com
\$43,050

City of St. Marks

October 23, 2014 completion date/on time
Designed, manufactured & deployed
68 Lingberg cubes & 18 EcoSystems reefs.
Contact Alan Richardson - (grouperboy@yahoo.comOAR)
2545 Blairstone Pines Drive Tallahassee, FL 32301

at (850) 656-2114.
\$67,000

Texas Parks & Wildlife

September 18, 2014 completion date/on time
155 ft. Ship deployed
Dale Shively [Dale.Shively@tpwd.texas.gov]
\$490,000

City of Carrabelle

July 26, 2015 completion date/on time
Funding - State of Florida
Designed, manufactured & deployed
30 Florida Limestone
1 Super Reef
Alan Richardson alan@talcor.com
\$67,000

2015

City of Mexico Beach

April 8, 2015 completion date/on time
Funding - State of Florida
Designed, manufactured & deployed 18 Florida Limestone
10 Super reefs
8 Grouper Reefs
2 EcoSystems units on pilings
1 Florida Special
Robert L. Cox Jr
rcox@mchsi.com
WWW.MBARA.ORG
\$165,000

City of Mexico Beach

April 8, 2015 completion date/on time
Designed, manufactured & deployed 18 Florida Limestone
4 Florida Limestone reefs
4 EcoSystems units on pilings
1 Florida Special
Robert L. Cox Jr
rcox@mchsi.com
WWW.MBARA.ORG
\$16,995

City of Carrabelle

July 26, 2015 completion date/on time

Funding - State of Florida
Designed, manufactured & deployed
6 Florida Limestone
8 EcoSystems on Pedestals
12 Lindberg boxes
Alan Richardson alan@talcor.com
\$55,000

Ocean Engineering cable reels
August 10, 2015 completion date/on time
Large 50 ton Cable Reels
Deployed in MBARA reef sites
Robert L. Cox Jr
rcox@mchsi.com
WWW.MBARA.ORG
\$73,000

MoBay Gas Platform
August, 2015 completion date/on time
Disassemble, transport & deploy a gas platform.
Reef was paid for by Mobay LLC and deployed as a public reef for the State of Alabama.
Craig Newton (Craig.Newton@dcnr.alabama.gov)
\$1,350,000

Escambia County
August 24, 2015 completion date/on time
Design, manufacture and depoy
12 Florida Limestone
Contact Robert Turpin 850-595-4395 (robert_turpin@co.escambia.fl.us)
\$19,200

City of Gulf Breeze
September 11, 2015 completion date/on time
238 EcoSystems Wave Barrier units
Design, manufacture and depoy
Heather Reed
Project Manager
The City of Gulf Breeze Deadman's Island Restoration Project
Ecological Consulting Services Inc
38 S Blue Angel Pkwy #346
Pensacola , FL 32506
850-417-7008
850-346-2073
\$423,500

Iberia Soil & Water Conservation District

November 14, 2015 completion date/on time

Design, manufacture and install 500 ft. of EcoSystems Wave Attenuator at Shark Island
Joey Breaux

Agri. Enviro. Specialist/Admin. Coord.

LDAF/Office of Soil & Water Conservation

225.922.1269

\$677,156

South Walton Artificial Reef Association

Oct. 7, 2015 completion date/on time

58 EcoSystems Snorkeling Reefs on Grayton Beach

SWARA, Inc. P.O. Box 2482 Santa Rosa Beach, FL 32459

info@waltonreefs.org

\$162,250

2016**Escambia County, Florida**

January 14, 2016 completion date/on time

Deployed tugboat Ocean Wind

Contact Robert Turpin 850-595-4395 (robert_turpin@co.escambia.fl.us)

\$18,000

Alabama Department of Conservation

March 22, 2016 completion date/on time

Designed, manufactured & deployed

150 - 8' Florida Limestone reef units

Craig Newton (Craig.Newton@dcnr.alabama.gov) or Kevin Anson

(Kevin.Anson@dcnr.alabama.gov) 251-968-7576, Alabama Department of Conservation, P.

O. Drawer 458, Gulf Shores, AL 36547

\$315,000

City of Mexico Beach

May 11, 2016 completion date/on time

Designed, manufactured & deployed

18 Florida Limestone

2 Grouper Reefs

1 Florida Special

8 coops

Robert L. Cox Jr

rcox@mchsi.com

WWW.MBARA.ORG

\$57,687

Bay County

May 14, 2016 completion date/on time
Designed, manufactured & deployed 5 Super Reefs
Allen Golden
agolden@baycountyfl.gov
205-567-0173
\$60,000

City of Mexico Beach

May 11, 2016 completion date/on time
Funding - State of Florida
Designed, manufactured & deployed
31 Florida Limestone
15 Grouper Reefs
Robert L. Cox Jr
rcox@mchsi.com
WWW.MBARA.ORG
\$84,990

Alabama Department of Conservation

June 30, 2016 completion date/on time
Deployed state supplied 7,289 tons of concrete culvert/boxes
Craig Newton (Craig.Newton@dcnr.alabama.gov) or Kevin Anson
(Kevin.Anson@dcnr.alabama.gov) 251-968-7576, Alabama Department of Conservation, P.
O. Drawer 458, Gulf Shores, AL 36547
\$121,000

State of Mississippi

June 16, 2016 completion date/on time
Built molds according to state supplied design, manufactured and deployed
229 Juvenile reef Fish Habitats
James Sanders - (James.Sanders@dmr.ms.gov) Artificial Reef Bureau Director | Office of
Marine Fisheries Mississippi Department of Marine Resources | dmr.ms.gov 1141 Bayview
Avenue | Biloxi, MS 39530 Office: 228-523-4089
\$194,250

Alabama Department of Conservation

Sept 15, 2016 completion date/on time
Deployed 50 Super Reefs & 125 EcoSystems on Pilings
Craig Newton (Craig.Newton@dcnr.alabama.gov) or Kevin Anson
(Kevin.Anson@dcnr.alabama.gov) 251-968-7576, Alabama Department of Conservation, P.
O. Drawer 458, Gulf Shores, AL 36547
\$1,041,000

Ocean Engineering cable reels

Sept. 17, 2016 completion date/on time

Five Large 50 ton Cable Reels

Deployed in MBARA reef sites

Robert L. Cox Jr

rcox@mchsi.com

\$40,000

City of Mexico Beach

Oct 14, 2016 completion date/on time

Funding - NRDA

Designed, manufactured & deployed

102 Florida Limestone

20 Super Reefs

Robert L. Cox Jr

rcox@mchsi.com

WWW.MBARA.ORG

\$427,174

City of Mexico Beach

Oct 15, 2016 completion date/on time

Funding - NRDA

Designed, manufactured & deployed

54 Florida Limestone

10 Super Reefs

Robert L. Cox Jr

rcox@mchsi.com

WWW.MBARA.ORG

\$219,004

Alabama Department of Conservation

Oct. 26, 2016 completion date/on time

Deployed 2 Super Reefs

Craig Newton (Craig.Newton@dcnr.alabama.gov) or Kevin Anson

(Kevin.Anson@dcnr.alabama.gov) 251-968-7576, Alabama Department of Conservation, P.

O. Drawer 458, Gulf Shores, AL 36547

\$26,025

City of Mexico Beach

Nov. 16, 2016 completion date/on time

Funding - NRDA

Designed, manufactured & deployed

66 Florida Limestone

Robert L. Cox Jr

rcox@mchsi.com

WWW.MBARA.ORG

\$119,999.88

2017

Alabama Department of Conservation

Feb. 15, 2017 completion date/on time

Deployed 132 EcoSystem Reefs on pilings

Craig Newton (Craig.Newton@dcnr.alabama.gov) or Kevin Anson

(Kevin.Anon@dcnr.alabama.gov) 251-968-7576, Alabama Department of Conservation, P.

O. Drawer 458, Gulf Shores, AL 36547

\$400,000

City of Mexico Beach

Feb. 17, 2017 completion date/on time

Funding - Local

Designed, manufactured & deployed

7 Memorial Reefs

6 Grouper Reefs

2 - EcoSystems on discs

5 Chicken Transport Devices

Robert L. Cox Jr

rcox@mchsi.com

WWW.MBARA.ORG

\$23,450

City of Mexico Beach

April 28, 2017 completion date/on time

Funding - FWC

Designed, manufactured & deployed

30 Grouper Reefs

Robert L. Cox Jr

rcox@mchsi.com

WWW.MBARA.ORG

\$60,000

City of Mexico Beach

May 10, 2017 completion date/on time

Funding - NRDA

Designed, manufactured & deployed

179 EcoSystems

Robert L. Cox Jr

rcox@mchsi.com

WWW.MBARA.ORG

\$568,998

Escambia County, Florida:

May 31, 2017 completion date/on time

Funding - NRDA

30 Florida Limesone Reef units and 8 Super Reefs.

Robert Turpin Escambia County Reef Coordinator robert_turpin@co.escambia.fl.us for 2003 contracts (850) 595-4395. Eileen Beard Escambia County Recreational board member since 1988 (850) 433-4319.

\$150,000

Walton County

July 21, 2017 completion date/ on time

Funding NRDA

170 Grouper reefs

185 Florida Limestone Reef units

Melinda Gates

Environmental Specialist, "Coastal Resource Liaison"

Phone: (850)892-8108

\$681,000

Walton County

July 23, 2017 completion date/ on time

Funding NRDA

254 EcoSystems Snorkeling Reefs

Melinda Gates

Environmental Specialist, "Coastal Resource Liaison"

Phone: (850)892-8108

\$803,148

Santa Rosa

Sept. 28, 2017 completion date/ on time

48 EcoSystems Snorkeling Reefs

Sheila Fitzgerald

Grants & Special Programs Director

Santa Rosa County Board of Commissioners

P: 850.981.2016 | C: 850.393.5239 | F: 850.981.2015

\$171,600

2018

City of Mexico Beach

April 23, 2018 completion date/on time Funding – FWC

Designed, manufactured & deployed

10 Super Reefs

8 Grouper Reefs

5 Florida Limestone pyramid

Robert L. Cox Jr

rcox@mchsi.com

WWW.MBARA.ORG

\$146,710

Mexico Beach Artificial Reef Association

April 23, 2018 completion date/on time

Funding - Private

Designed, manufactured & deployed

7 - 10' Florida Limestone Pyramids

3 - 8' Florida Limestone Pyramids

1 Grouper

Robert L. Cox Jr

rcox@mchsi.com

WWW.MBARA.ORG

\$21,700

Alabama Department of Conservation

April 24, 2017 completion date/on time

Funding - NRDA

Deployed Concrete Pipe & one Tugboat

Craig Newton (Craig.Newton@dcnr.alabama.gov) or Kevin Anson

(Kevin.Anon@dcnr.alabama.gov) 251-968-7576, Alabama Department of Conservation, P.

O. Drawer 458, Gulf Shores, AL 36547

\$179,000

Alabama Department of Conservation

June 18,2018 completion date/on time

Funding - NRDA

Deployed 120 Super Reefs

Craig Newton (Craig.Newton@dcnr.alabama.gov) or Kevin Anson

(Kevin.Anon@dcnr.alabama.gov) 251-968-7576, Alabama Department of Conservation, P.

O. Drawer 458, Gulf Shores, AL 36547

\$1,209,000

Walton County

June 2018 completion date/ on time

Funding FWC

12 Florida Limestone Pyramid Reefs

10 EcoSystems on Pedestals

14 Lingberg Cubes

Melinda Gates

Environmental Specialist, "Coastal Resource Liaison"

Phone: (850)892-8108

\$59,800

South Walton Artificial Reef Association

June 27, 2018 completion date/on time

Underwater Museum

SWARA, Inc. P.O. Box 2482 Santa Rosa Beach, FL 32459

info@waltonreefs.org

\$10,500

Santa Rosa

Sept. 24, 2018 Ongoing project scheduled completion 12/31/2018

Funding - NRDA

40 Florida Limestone Pyramid Reefs

26 Grouper

22 Super Reefs

Sheila Fitzgerald

Grants & Special Programs Director

Santa Rosa County Board of Commissioners

P: 850.981.2016 | C: 850.393.5239 | F: 850.981.2015

\$1,224,200

Alabama Department of Conservation

Oct. 15, 2018 completion date/on time

Funding - NRDA

Deployed 600 10' Florida Limestone Reefs

Craig Newton (Craig.Newton@dcnr.alabama.gov) or Kevin Anson

(Kevin.Anson@dcnr.alabama.gov) 251-968-7576, Alabama Department of Conservation, P.

O. Drawer 458, Gulf Shores, AL 36547

\$1,200,000

Alabama Department of Conservation

Nov. 20, 2018 completion date/on time

Funding - NRDA

Deployed 166 Snorkel Reefs

Craig Newton (Craig.Newton@dcnr.alabama.gov) or Kevin Anson

(Kevin.Anson@dcnr.alabama.gov) 251-968-7576, Alabama Department of Conservation, P.

O. Drawer 458, Gulf Shores, AL 36547

\$590,345

2019

Escambia County, Florida:

March 15/2019

Funding - NRDA

304 Florida Limestone, 44 Super Reefs

Robert Turpin Escambia County Reef Coordinator robert_turpin@co.escambia.fl.us for 2003 contracts (850) 595-4395. Eileen Beard Escambia County Recreational board member since 1988 (850) 433-4319.

Santa Rosa

March 15, 2019

Funding - NRDA

269 Florida Limestone Pyramid Reefs

153 Grouper

22 Super Reefs

Sheila Fitzgerald

Grants & Special Programs Director

Santa Rosa County Board of Commissioners

P: 850.981.2016 | C: 850.393.5239 | F: 850.981.2015

\$1,224,200

Okaloosa County

April 19, 2019

Funding - NRDA

205 EcoSystem pile mounted snorkeling reefs

Okaloosa County Commissioners

Alex Fogg

Marine Resource Coordinator

(850) 609-5394

\$719,998

Okaloosa County

April 30, 2019

Funding - NRDA

14 Super Reefs

310 8' Florida Limestone

113 Grouper

Okaloosa County Commissioners

Alex Fogg

Marine Resource Coordinator

(850) 609-5394

\$978,441

Okaloosa County

July 31, 2019

Funding - NRDA

12 Super Reefs

Okaloosa County Commissioners

Alex Fogg

Marine Resource Coordinator

(850) 609-5394

\$120,000

Walton County

July 31 2019

Funding FWC

5 Florida Limestone Pyramid Reefs

48 Florida Limestone

4 Grouper

Melinda Gates

Environmental Specialist, "Coastal Resource Liaison"

Phone: (850)892-8108

\$152,000

Texas Parks & Wildlife Department

Purchase Order #518406

November 8, 2019 completion date/on time

Manufactured & deployed

180 Low Relief reefs

Dale Shively 512-389-4686

\$234,000

2020

Boy Scouts of America Troop 49

May 8, 2020 completion date/on time

Funding - Private

Deployed 60' shrimp boat

Garret Ard

251-979-9266

\$25,000

Mexico Beach Artificial Reef Association

May 18, 2020 completion date/on time

Funding - Private

Designed, manufactured & deployed

6 - 8' Florida Limestone Pyramids

3 - EcoSystems reefs

1 - Grouper reef

Robert L. Cox Jr

rcox@mchsi.com

WWW.MBARA.ORG

\$44,739

City of Mexico Beach

May 18, 2020 completion date/on time

Funding – FWC

Designed, manufactured & deployed

6 Super Reefs

17 Florida Limestone pyramid

Robert L. Cox Jr

rcox@mchsi.com

WWW.MBARA.ORG

\$92,309

Okaloosa County

May 28, 2020 completion date/on time

Funding - NRDA

35 - 8' pyramids

5 - Super Reefs

Okaloosa County Commissioners

Alex Fogg

Marine Resource Coordinator

(850) 609-5394

\$120,000

Escambia County, Florida:

June 18/2020 completion date/on time

Funding - NRDA

17 Snorkel reefs

Robert Turpin Escambia County Reef Coordinator robert_turpin@co.escambia.fl.us for 2003 contracts (850) 595-4395. Eileen Beard Escambia County Recreational board member since 1988 (850) 433-4319.

\$59,500

Alabama Department of Conservation

July 8, 2020 completion date/on time

Funding - NRDA

Deployed 327 anchored shallow-water limestone and concrete matrix type reefs

Craig Newton (Craig.Newton@dcnr.alabama.gov) or Kevin Anson (Kevin.Anson@dcnr.alabama.gov)

251-968-7576, Alabama Department of Conservation, P. O. Drawer 458, Gulf Shores, AL 36547

\$1,140,000

City of Mexico Beach

August 12, 2020 completion date/on time

Funding – FWC

Designed, manufactured & deployed

9 Super Reefs

27 Florida Limestone pyramid

3 Grouper

Robert L. Cox Jr

rcox@mchsi.com

WWW.MBARA.ORG

\$157,200

Okaloosa County

August 11, 2020 completion date/on time

Funding - NRDA

4 FADs

Okaloosa County Commissioners

Alex Fogg

Marine Resource Coordinator

(850) 609-5394

\$312,996

Alabama Wildlife Federation Inc.

Sept. 8, 2020 completion date/on time

3050 Lanark Rd.

Millbrook, AL 36054

Culverts

\$25,600

Bay County

Oct. 27, 2020 completion date/on time

Designed, manufactured & deployed 10 Super Reefs & 23 - 8' pyramids

Allen Golden

agolden@baycountyfl.gov

205-567-0173

\$142,179

Bay County

Nov. 2, 2020 completion date/on time

Designed, manufactured & deployed 8 Super Reefs & 23 - 8' pyramids

Allen Golden

agolden@baycountyfl.gov

205-567-0173

\$125,749

Bay County

Nov. 16, 2020 completion date/on time

Designed, manufactured & deployed 8 Super Reefs & 40- 8' pyramids

Allen Golden

agolden@baycountyfl.gov

205-567-0173

\$152,209

Bay County

Nov. 23, 2020 completion date/on time

Designed, manufactured & deployed 8 Super Reefs & 23- 8' pyramids

Allen Golden

agolden@baycountyfl.gov

205-567-0173

\$125,749

Bay County

Dec. 12, 2020 completion date/on time

Designed, manufactured & deployed 9 Super Reefs & 22- 8' pyramids

Allen Golden

agolden@baycountyfl.gov

205-567-0173

\$131,129

Bay County

Dec. 22, 2020 completion date/on time

Designed, manufactured & deployed 8 Super Reefs & 27- 8' pyramids

Allen Golden

agolden@baycountyfl.gov

205-567-0173

\$128,809

2021**Santa Rosa**

January 6, 2021 completion date/on time

Funding - FWC

269 Florida Limestone Pyramid Reefs

9 Grouper

2 Super Reefs

31 FLAR

Sheila Fitzgerald

Grants & Special Programs Director

Santa Rosa County Board of Commissioners

P: 850.981.2016 | C: 850.393.5239 | F: 850.981.2015

\$99,237.63

Navarre Chamber Foundation

January 6, 2021 completion date/on time

Self

5 Super Reefs

Mike Sandler <mjsandler@bellsouth.net>

\$55,637.90

State of Florida

Department of State

I certify from the records of this office that WALTER MARINE is a Fictitious Name registered with the Department of State on May 8, 2002.

The Registration Number of this Fictitious Name is G02128900237.

I further certify that said Fictitious Name Registration is active.

I further certify that said Fictitious Name Registration filed a renewal on June 6, 2017, and expires on December 31, 2022.

Given under my hand and the Great Seal of Florida, at Tallahassee, the Capital, this the Seventh day of June, 2017



Authentication ID: **100300043281-060717-G02128900237**

To authenticate this certificate, visit the following site, enter this ID, and then follow the instructions displayed.

<https://efile.sunbiz.org/certauthver.html>



TOWN OF DAVIE
Business Tax Receipts Division
 6591 Orange Drive, Davie, FL 33314
 Telephone: 954-797-1212
 Email: btr@davie-fl.gov
 Website: www.davie-fl.gov

Business Name: **WALTER MARINE**
 Address: **4651 SW 74 TER**
 City, ST, Zip: **DAVIE, FL, 33314**

	<p>TOWN OF DAVIE Business Tax Receipt Effective Date: 10/1/2020 Expiration Date: 9/30/2021</p>	<p>License Number 158</p>		
<table border="0" style="width: 100%;"> <tr> <td style="width: 50%;"> DBA Name: Business Name: WALTER MARINE Address: 4651 SW 74 TER City, ST, Zip: Davie, FL, 33314 </td> <td style="width: 50%;"> Business Phone: (251) 979-2200 Square Footage: </td> </tr> </table>			DBA Name: Business Name: WALTER MARINE Address: 4651 SW 74 TER City, ST, Zip: Davie, FL, 33314	Business Phone: (251) 979-2200 Square Footage:
DBA Name: Business Name: WALTER MARINE Address: 4651 SW 74 TER City, ST, Zip: Davie, FL, 33314	Business Phone: (251) 979-2200 Square Footage:			
<p>License Type: Offices Desk Space No Stock</p>				
<p>CERTIFICATE OF USE</p>				
<p>*The Business Tax Receipt is an acknowledgment that a Business Tax has been paid pursuant to Sec. 13-17 of the Town Code. Please contact the Towns Business Tax Receipt Division if the business has ceased, moved or changed ownership.</p> <p>**The Certificate of Use is an acknowledgment that the business was determined to have met the requirements of Sec. 12-382 of the Town Code. If blank, Certificate of Use details are on file with Business Tax Receipts Division.</p>				

Company ID Number: 475488

Approved by:

Employer Waller/Memo	
Name (Please Type or Print) Gaur M Waller	Title
Signature Electronically Signed	Date 05/23/2018
Department of Homeland Security – Verification Division	
Name (Please Type or Print) USCIS Verification Division	Title
Signature Electronically Signed	Date 05/23/2018

Company ID Number: 572000

Information Required for the E-Verify Program

Information relating to your Company:

Company Name	Water Works
Company Facility Address	32606 Andrews Lane Orange Beach, AL 36561
Company Alternate Address	PO Box 106 Orange Beach, AL 36561
County or Parish	SACALVIN
Employer Identification Number	42259900
North American Industry Classification System Code	534
Parent Company	
Number of Employees	1894
Number of Sites Verified for	1

FRANKLIN COUNTY, FLORIDA
2021 BUDDY WARD ARTIFICIAL REEF PROJECT

REQUEST FOR PROPOSALS
ADDENDUM #1 DATED 03/22/21
RFP # 2020-01

Contractor must comply with ALL federal requirements listed in the attached FWC Grant Agreement 20011

**STATE OF FLORIDA
FLORIDA FISH AND WILDLIFE CONSERVATION COMMISSION**

AGREEMENT NO. 20011

CFDA Title(s): Federal Aid in Sportfish Restoration	CFDA No(s): 15.605
Name of Federal Agency(s): U.S. Fish and Wildlife Service	
Federal Award No(s): FL-F-F20AF11284	Federal Award Year(s): 2020-2021
Federal Award Name(s): Marine Artificial Reef Planning, Development, Administration, and Assessment in Florida	
CSFA Title(s): Florida Artificial Reef Program	CSFA No(s): N/A
State Award No(s): FWC-20011	State Award Year(s): N/A
State Award Name(s): Franklin County Artificial Reef Construction 2020-21	

This Agreement is entered into by and between the Florida Fish and Wildlife Conservation Commission, whose address is 620 South Meridian Street, Tallahassee, Florida 32399-1600, hereafter "Commission," and Franklin County Board of Commissioners, FEID # 59-6000612, address is 33 Market Street, Suite 203, Apalachicola, FL 32320, hereafter "Grantee."

WHEREAS, the Commission and Grantee have partnered together to construct three artificial reef complexes by deploying at least 25 concrete prefabricated reef modules within Buddy Ward permitted area; and,

WHEREAS, Grantee has been awarded the grant entitled "Franklin County Artificial Reef Construction 2020-2021/ FWC-20011; and,

WHEREAS, such benefits are for the ultimate good of the State of Florida, its resources, wildlife, and public welfare.

NOW THEREFORE, the Commission and the Grantee, for the considerations hereafter set forth, agree as follows:

1. PROJECT DESCRIPTION.

The Grantee shall provide the services and perform the specific responsibilities and obligations, as set forth in the Scope of Work, attached hereto as Attachment A and made a part hereof (hereafter, Scope of Work). The Scope of Work specifically identifies project tasks and accompanying deliverables. These deliverables must be submitted and approved by the Commission prior to any payment. The Commission will not accept any deliverable that does not comply with the specified required minimum level of service to be performed and the criteria for evaluating the successful completion of each deliverable. If this agreement is the result of Grantee responses to the Commission's request for competitive or other grant proposals, the Grantee's response is hereby incorporated by reference.

2. PERFORMANCE.

The Grantee shall perform the activities described in the Scope of Work in a proper and satisfactory manner. Unless otherwise provided for in the Scope of Work, any and all equipment, products or materials necessary or appropriate to perform under this Agreement shall be supplied by the Grantee. Grantee shall obtain all necessary local, state, and federal authorizations necessary to complete this project, and the Grantee shall be licensed as necessary to perform under this Agreement as may be required by law, rule, or regulation; the Grantee shall provide evidence of such compliance to the Commission upon request. The Grantee shall procure all supplies and pay all charges, fees, taxes and incidentals that may be required for the completion of this Agreement. By acceptance of this Agreement, the Grantee warrants that it has the capability in all respects to fully perform the requirements and the integrity and reliability that will assure good-faith performance as a responsible Grantee. Grantee shall immediately notify the Commission's Grant Manager in writing if its ability to perform under the Agreement is compromised in any manner during the term of the Agreement. The Commission shall take appropriate action, including potential termination of this Agreement pursuant to Paragraph eight (8) below, in the event the Grantee's ability to perform under this Agreement becomes compromised.

3. AGREEMENT PERIOD.

A. Agreement Period and Commission's Limited Obligation to Pay. This Agreement is made pursuant to a grant award and shall be effective upon execution by the last Party to sign and shall remain in effect through ~~08/31/2021~~. However, as authorized by Rule 68-1.003, F.A.C., referenced grant programs may execute Agreements with a retroactive start date of no more than sixty (60) days, provided that approval is granted from the Executive Director or his/her designee and that it is in the best interest of the Commission and State to do so. For this agreement, the retroactive start date was not approved. The Commission's Grant Manager shall confirm the specific start date of the Agreement by written notice to the Grantee. The Grantee shall not be eligible for reimbursement or compensation for grant activities performed prior to the start date of this Agreement nor after the end date of the Agreement. For this agreement, preaward costs are not eligible for reimbursement. If necessary, by mutual agreement as evidenced in writing and lawfully executed by the Parties, an Amendment to this Agreement may be executed to lengthen the Agreement period.

4. COMPENSATION AND PAYMENTS.

A. Compensation. As consideration for the services rendered by the Grantee under the terms of this Agreement, the Commission shall pay the Grantee on a cost reimbursement basis in an amount not to exceed \$60,000.00.

B. Payments. The Commission shall pay the Grantee for satisfactory performance of the tasks identified in Attachment A, Scope of Work, as evidenced by the completed deliverables, upon submission of invoices, accompanied by supporting documentation sufficient to justify invoiced expenses or fees, and after acceptance of services and deliverables in writing by the Commission's Grant Manager identified in Paragraph ten (10), below. Unless otherwise specified in the Scope of Work, invoices shall be due monthly, commencing from the start date of this Agreement. Invoices must be legible and must clearly reflect the Deliverables that were provided in accordance with the terms of the Agreement for the invoice period. Unless otherwise specified in the Scope of Work, a final invoice shall be submitted to the Commission no later than forty-five (45) days following the expiration date of this Agreement to assure the availability of funds for payment. Further, pursuant to Section 215.971(1)(d), F.S., the Commission may only reimburse the Grantee for

allowable costs resulting from obligations incurred during the agreement period specified in Paragraph three (3).

- C. Invoices.** Each invoice shall include the Commission Agreement Number and the Grantee's Federal Employer Identification (FEID) Number. Invoices, with supporting documentation, may be submitted electronically to the attention of the Commission's Grant Manager identified in Paragraph ten (10), below. If submitting hard copies, an original and two (2) copies of the invoice, plus all supporting documentation, shall be submitted. All bills for amounts due under this Agreement shall be submitted in detail sufficient for a proper pre-audit and post-audit thereof. Grantee acknowledges that the Commission's Grant Manager shall reject invoices lacking documentation necessary to justify invoiced expenses.
- D. Match.** Pursuant to grant program guidelines, the Grantee is required to contribute non-federal match towards this Agreement. If applicable, details regarding specific match requirements are included in Attachment A, Scope of Work.
- E. Travel Expenses.** If authorized in Attachment A, Scope of Work, travel expenses shall be reimbursed in accordance with Section 112.061, F.S.
- F. State Obligation to Pay.** The State of Florida's performance and obligation to pay under this Agreement is contingent upon an annual appropriation and authorization to spend by the Legislature. The Parties hereto understand that this Agreement is not a commitment to future appropriations but is subject to appropriation and authority to spend provided by the Legislature. The Commission shall be the final authority as to the availability of funds for this Agreement, and as to what constitutes an "annual appropriation" of funds to complete this Agreement. If such funds are not appropriated or available for the Agreement purpose, such event will not constitute a default on behalf of the Commission or the State. The Commission's Grant Manager shall notify the Grantee in writing at the earliest possible time if funds are not appropriated or available.
- G. Non-Competitive Procurement and Rate of Payment.** Section 216.3475, F.S., requires that under non-competitive procurements, a Grantee may not receive a rate of payment in excess of the competitive prevailing rate for those services unless expressly authorized in the General Appropriations Act. If applicable, Grantee warrants, by execution of this Agreement, that the amount of non-competitive compensation provided in this Agreement is in compliance with Section 216.3475, F.S.
- H. Time Limits for Payment of Invoices.** Payments shall be made in accordance with Sections 215.422 and 287.0585, F.S., which govern time limits for payment of invoices. Section 215.422, F.S. provides that agencies have five (5) working days to inspect and approve Deliverables, unless the Scope of Work specifies otherwise. If payment is not available within forty (40) days, measured from the latter of the date the invoice is received or the Deliverables are received, inspected and approved, a separate interest penalty set by the Department of Financial Services pursuant to Section 55.03(1), F.S., will be due and payable in addition to the invoice amount. Invoices returned to a Grantee due to preparation errors will result in a payment delay. Invoice payment requirements do not start until a properly completed invoice is provided to the agency.
- I. Electronic Funds Transfer.** Grantee agrees to enroll in Electronic Funds Transfer (EFT), offered by the State's Chief Financial Officer, within thirty (30) days of the date the last Party has signed this Agreement. Copies of the Authorization form and a sample blank enrollment letter can be found on the vendor instruction page at:

http://www.fldfs.com/aadir/direct_deposit_web/Vendors.htm

Questions should be directed to the State of Florida's EFT Section at (850) 413-5517. Once enrolled, invoice payments will be made by EFT.

- J. **Vendor Ombudsman.** A Vendor Ombudsman, whose duties include acting as an advocate for vendors who may be experiencing problems in obtaining timely payment(s) from a State agency, may be contacted at (850) 413-5516 or by calling the Chief Financial Officer's Hotline, (800) 342-2762.

5. **RETURN OR RECOUPMENT OF FUNDS.**

- A. **Overpayment to Grantee.** Pursuant to Section 215.971(1)(e) &(f), F.S., the Grantee shall return to the Commission any overpayments due to unearned funds or funds disallowed pursuant to the terms of this Agreement that were disbursed to Grantee by the Commission. In the event the Grantee or its independent auditor discovers that overpayment has been made, the Grantee shall repay said overpayment within forty (40) calendar days without prior notification from the Commission. In the event the Commission first discovers an overpayment has been made, the Commission will notify the Grantee in writing. Should repayment not be made in a timely manner, the Commission shall be entitled to charge interest at the lawful rate of interest established pursuant to Section 55.03(1), F.S., on the outstanding balance beginning forty (40) calendar days after the date of notification or discovery. Refunds should be sent to the Commission's Grant Manager and made payable to the "The Florida Fish and Wildlife Conservation Commission".
- B. **Additional Costs or Monetary Loss Resulting from Grantee Non-Compliance.** If the Grantee's non-compliance with any provision of the Agreement results in additional cost or monetary loss to the Commission or the State of Florida to the extent allowed by Florida Law, the Commission can recoup that cost or loss from monies owed to the Grantee under this Agreement or any other agreement between Grantee and the Commission. In the event the discovery of this cost or loss arises when no monies are available under this Agreement or any other agreement between the Grantee and the Commission, the Grantee will repay such cost or loss in full to the Commission within thirty (30) days of the date of notice of the amount owed, unless the Commission agrees, in writing, to an alternative timeframe. If the Grantee is unable to repay any cost or loss to the Commission, the Commission shall notify the State of Florida, Department of Financial Services, for resolution pursuant to Section 17.0415, F.S.

6. **COMMISSION EXEMPT FROM TAXES, PROPERTY EXEMPT FROM LIEN.**

- A. **Commission Exempt from Taxes.** The Grantee recognizes that the State of Florida, by virtue of its sovereignty, is not required to pay any taxes on the services or goods purchased under the terms of this Agreement. Grantee is placed on notice that this exemption generally does not apply to nongovernmental entity recipients, subrecipients, contractors, or subcontractors. Any questions regarding this tax exemption should be addressed to the Commission Grant Manager.
- B. **Property Exempt from Lien.** If the Grant involves the improvement of real property titled to the State of Florida, then the following paragraph applies:

The Grantee acknowledges that Property being improved is titled to the State of Florida and is not subject to lien of any kind for any reason. The Grantee shall include notice of such exemptions in any subcontracts and purchase orders issued hereunder.

7. MONITORING.

The Commission's Grant Manager shall actively monitor the Grantee's performance and compliance with the terms of this Agreement. The Commission reserves the right for any Commission staff to make scheduled or unscheduled, announced or unannounced monitoring visits. Specific State and Federal monitoring terms and conditions are found in Attachment B, Audit Requirements. Additionally, monitoring terms, conditions, and schedules may be included in Attachment A, Scope of Work.

8. TERMINATION.

- A. Commission Termination.** The Commission may unilaterally terminate this Agreement for convenience by providing the Grantee with thirty (30) calendar days of written notice of its intent to terminate. The Grantee shall not be entitled to recover any cancellation charges or lost profits. The Grantee may request termination of the Agreement for convenience.
- B. Termination – Fraud or Willful Misconduct.** This Agreement shall terminate immediately in the event of fraud or willful misconduct. In the event of such termination, the Commission shall provide the Grantee with written notice of termination.
- C. Termination – Other.** The Commission may terminate this Agreement if the Grantee fails to: 1.) comply with all terms and conditions of this Agreement; 2.) produce each deliverable within the time specified by the Agreement or extension; 3.) maintain adequate progress, thus endangering the performance of the Agreement; or, 4.) abide by any statutory, regulatory, or licensing requirement. Rule 60A-1.006(3), F.A.C., governs the procedure and consequences for default. The rights and remedies of the Commission in this clause are in addition to any other rights and remedies provided by law or under the Agreement. The Grantee shall not be entitled to recover any cancellation charges or lost profits.
- D. Termination - Funds Unavailability.** In the event funds to finance this Agreement become unavailable or if federal or state funds upon which this Agreement is dependent are withdrawn or redirected, the Commission may terminate this Agreement upon no less than twenty-four (24) hours' notice in writing to the Grantee. Said notice shall be delivered by certified mail, return receipt requested or in person with proof of delivery. The Commission shall be the final authority as to the availability of funds and will not reallocate funds appropriated for this Agreement to another program thus causing "lack of funds." In the event of termination of this Agreement under this provision, the Grantee will be compensated for any work satisfactorily completed and any non-cancellable obligations properly incurred prior to notification of termination.
- E. Grantee Discontinuation of Activities upon Termination Notice.** Upon receipt of notice of termination, the Grantee shall, unless the notice directs otherwise, immediately discontinue all activities authorized hereunder. Upon termination of this Agreement, the Grantee shall promptly render to the Commission all property belonging to the Commission. For the purposes of this section, property belonging to the Commission shall include, but shall not be limited to, all books and records kept on behalf of the Commission.

9. REMEDIES.

- A. Financial Consequences.** In accordance with Sections 215.971(1)(a) &(b), F.S., Attachment A, Scope of Work, contains clearly established tasks in quantifiable units of deliverables that must be

received and accepted in writing by the agency before payment. Each deliverable specifies the required minimum level of service to be performed and the criteria for evaluating the successful completion of each deliverable. If the Grantee fails to produce each deliverable within the time frame specified by the Scope of Work, the budget amount allocated for that deliverable will be deducted from the Grantee's payment. In addition, pursuant to Section 215.971(1)(c), the Commission shall apply any additional financial consequences, identified in the Scope of Work.

- B. **Cumulative Remedies.** The rights and remedies of the Commission in this paragraph are in addition to any other rights and remedies provided by law or under the Agreement.

10. NOTICES AND CORRESPONDENCE.

Any and all notices shall be delivered to the individuals identified below. In the event that either Party designates a different Grant Manager after the execution of this Agreement, the Party will provide written notice of the name, address, zip code, telephone and fax numbers, and email address of the newest Grant Manager, or an individual authorized to receive notice on behalf of that Party, to all other Parties as soon as possible, but not later than five (5) business days after the new Grant Manager has been named. A designation of a new Grant Manager shall not require a formal amendment to the Agreement.

FOR THE COMMISSION:

Grant Manager
Christine Kittle
Fisheries Biologist IV
Division of Marine Fisheries Management
1875 Orange Ave. East
Tallahassee, FL 32311
(850)617-9628
Fax: N/A
Christine.kittle@myfwc.com

FOR THE GRANTEE:

Grant Manager
Michael Moron
Administrative Assistant
Franklin County Board of County Commissioners
33 Market Street, Suite 203
Apalachicola, FL 32320
Phone: (850) 653-9783 ext. 155
Fax: N/A
michael@franklincountyflorida.com

11. AMENDMENT.

- A. **Waiver or Modification.** No waiver or modification of this Agreement or of any covenant, condition, or limitation herein contained shall be valid unless in writing and lawfully executed by the Parties.
- B. **Change Orders.** The Commission may, at any time, by written order, make a change to this Agreement. Such changes are subject to the mutual agreement of both Parties as evidenced in writing. Any change which causes an increase or decrease in the Grantee's cost or time shall require an Amendment. Minor changes, such as those updating a Party's contact information, may be accomplished by a Modification.
- C. **Renegotiation upon Change in Law or Regulation.** The Parties agree to renegotiate this Agreement if federal and/or state revisions of any applicable laws or regulations make changes in the Agreement necessary.

12. PROPERTY RIGHTS.

If this Agreement includes Federal funds, the provisions of Sections 200.310-200.316, OMB Uniform Guidance (2 CFR 200), and any language addressing Federal rights, apply.

- A. **Intellectual and Other Intangible Property.**

- i. **Grantee's Preexisting Intellectual Property (Proprietary) Rights.** Unless specifically addressed in the Attachment A, Scope of Work, intellectual and other intangible property rights to the Grantee's preexisting property will remain with the Grantee.
- ii. **Proceeds Related to Intellectual Property Rights.** Proceeds derived from the sale, licensing, marketing or other authorization related to any intellectual and other intangible property right created or otherwise developed by the Grantee under this Agreement for the Commission shall be handled in the manner specified by the applicable Florida State Statute and/or Federal program requirements.
- iii. **Commission Intellectual Property Rights.** Where activities supported by this Agreement produce original writing, sound recordings, pictorial reproductions, drawings or other graphic representations and works of any similar nature, the Commission and the State of Florida have the unlimited, royalty-free, nonexclusive, irrevocable right to use, duplicate and disclose such materials in whole or in part, in any manner, for any purpose whatsoever and to have others acting on behalf of the Commission to do so. If this Agreement is supported by federal funds, the federal awarding agency reserves a royalty-free, nonexclusive and irrevocable right to reproduce, publish, or otherwise use the work for federal purposes, and to authorize others to do so.

B. Purchase or Improvement of Real Property

~~This agreement is not for the purchase or improvement of real property, therefore, the following terms and conditions do not apply.~~

- i. **Federal Funds.** Any Federal funds provided for the purchase of or improvements to real property are subject to the Property Standards of Sections 200.310 - 200.316, and 200.329, OMB Uniform Guidance (2 CFR 200), as amended.
 - ii. **Title.** If this agreement is supported by state funds, the Grantee shall comply with Section 287.05805, F.S. This section requires the Grantee to grant a security interest in the property to the State of Florida, the type and details of which are provided for in Attachment A, Scope of Work. Title to state-owned real property remains vested in the state. Title to federally-owned real property remains vested in the Federal government in accordance with the provisions of Section 200.312, OMB Uniform Guidance (2 CFR 200), as amended.
 - iii. **Use.** Federally-owned real property will be used for the originally authorized purpose as long as needed for that purpose in accordance with Section 200.311, OMB Uniform Guidance (2 CFR 200). State-owned real property will be used as provided in Attachment A, Scope of Work.
- C. Non-Expendable Property.** The following provisions apply to the extent that the grant allows the acquisition of non-expendable property.
- i. **Non-Expendable Property Defined.** For the requirements of this section of the Agreement, "non-expendable property" is the same as "property" as defined in Section 273.02, F.S. (equipment, fixtures, and other tangible personal property of a non-consumable and non-expendable nature, with a value or cost of \$1,000.00 or more, and a normal expected life of one (1) year or more; hardback-covered bound books that are circulated to students or the general public, with a value or cost of \$25.00 or more; and uncirculated hardback-covered bound books, with a value or cost of \$250.00 or more).

- ii. **Title to Non-Expendable Property.** Title (ownership) to all non-expendable property acquired with funds from this Agreement shall be vested in the Commission and said property shall be transferred to the Commission upon completion or termination of the Agreement unless otherwise authorized in writing by the Commission or unless otherwise specifically provided for in Attachment A, Scope of Work.

D. Equipment and Supplies. The following provisions apply to the extent that the grant allows the acquisition of equipment and supplies.

- i. **Title - Equipment.** Title to equipment acquired under a Federal award will vest upon acquisition in the non-Federal entity in accordance with Sections 200.313 and 200.314, OMB Uniform Guidance (2 CFR 200).
- ii. **Title – Supplies.** Title to supplies will vest in the non-Federal entity upon acquisition. Unused supplies exceeding \$5,000.00 in total aggregate value upon termination or completion of the project or program are subject to Section 200.314, OMB Uniform Guidance.
- iii. **Use – Equipment.** Equipment must be used by the non-Federal entity in the program or project for which it was acquired as long as needed

13. RELATIONSHIP OF THE PARTIES.

- A. **Independent Grantee.** The Grantee shall perform as an independent grantee and not as an agent, representative, or employee of the Commission. The Grantee covenants that it presently has no interest and shall not acquire any interest that would conflict in any manner or degree with the performance of services required. Each Party hereto covenants that there is no conflict of interest or any other prohibited relationship between the Grantee and the Commission.
- B. **Grantee Training and Qualifications.** Grantee agrees that all Grantee employees, subcontractors, or agents performing work under the Agreement shall be properly trained technicians who meet or exceed any specified training qualifications. Upon request, Grantee shall furnish a copy of technical certification or other proof of qualification.
- C. **Commission Security.** All employees, subcontractors, or agents performing work under the Agreement must comply with all security and administrative requirements of the Commission. The Commission may conduct, and the Grantee shall cooperate in, a security background check or otherwise assess any employee, subcontractor, or agent furnished by the Grantee. The Commission may refuse access to, or require replacement of, any personnel for cause, including, but not limited to, technical or training qualifications, quality of work, change in security status, or non-compliance with the Commission's other requirements. Such refusal shall not relieve Grantee of its obligation to perform all work in compliance with the Agreement. The Commission, in coordination with the Grantee, may reject and bar from any facility for cause any of Grantee's employees, subcontractors, or agents.
- D. **Commission Rights to Assign or Transfer.** The Grantee agrees that the State of Florida shall at all times be entitled to assign or transfer its rights, duties, or obligations under this Agreement to another governmental agency in the State of Florida, upon giving prior written notice to the Grantee.

- E. Commission Rights to Undertake and Award Supplemental Agreements.** Grantee agrees that the Commission may undertake or award supplemental agreements for work related to the Agreement. The Grantee and its subcontractors shall cooperate with such other Grantees and the Commission in all such cases.

14. SUBCONTRACTS.

- A. Authority.** ~~Grantee is permitted to subcontract work under this Agreement; therefore, the following terms and conditions apply.~~ The Grantee shall ensure, and provide assurances to the Commission upon request, that any subcontractor selected for work under this Agreement has the necessary qualifications and abilities to perform in accordance with the terms and conditions of this Agreement. The Grantee must provide the Commission with the names of any subcontractor considered for work under this Agreement; the Commission in coordination with the Grantee reserves the right to reject any subcontractor. The Grantee agrees to be responsible for all work performed and all expenses incurred with the project. Any subcontract arrangements must be evidenced by a written document available to the Commission upon request. The Grantee further agrees that the Commission shall not be liable to the extent allowed by law, to any subcontractor for any expenses or liabilities incurred under the subcontract and the Grantee shall be solely liable to the subcontractor for all expenses and liabilities incurred under the subcontract.
- B. Grantee Payments to Subcontractor.** If subcontracting is permitted pursuant to Paragraph A, above, Grantee agrees to make payments to the subcontractor upon completion of work and submitted invoice in accordance with the contract between the Grantee and subcontractor. Failure to make payment pursuant to any subcontract will result in a penalty charged against Grantee and paid to the subcontractor in the amount of one-half of one percent (0.50%) of the amount due per day from the expiration of the period allowed herein for payment. Such penalty shall be in addition to actual payments owed and shall not exceed fifteen percent (15%) of the outstanding balance due.
- C. Commission Right to Reject Subcontractor Employees.** The Commission in coordination with Grantee shall retain the right to reject any of the Grantee's or subcontractor's employees whose qualifications or performance, in the Commission's judgment, are insufficient.
- D. Subcontractor as Independent Contractor.** If subcontracting is permitted pursuant to Paragraph A above, the Grantee agrees to take such actions as may be necessary to ensure that each subcontractor will be deemed to be an independent contractor and will not be considered or permitted to be an agent, servant, joint venture, or partner of the State of Florida.

15. MANDATORY DISCLOSURE.

These disclosures are required by State law, as indicated, and apply when this Agreement includes State funding; and by Federal law, as indicated, and apply when the Agreement includes a Federal award.

- A. Disclosure of Interested State Employees and Conflict of Interest.** This Agreement is subject to Chapter 112, F.S. Grantee shall provide the name of any officer, director, employee, or other agent who is affiliated with this project and an employee of the State of Florida. If the Agreement includes a Federal award, then the Agreement is also subject to Section 200.112, OMB Uniform Guidance (2 CFR 200). Grantee must disclose, in writing, any potential conflict of interest to the Commission in accordance with applicable Federal awarding agency policy.
- B. Convicted Vendors.** Grantee hereby certifies that neither it, nor any person or affiliate of Grantee, has been convicted of a Public Entity Crime as defined in section 287.133, F.S., nor placed on the convicted vendor list. Grantee shall have a continuing obligation to disclose, to the Commission,

in writing, if it, its principals, recipient, subrecipient, contractor, or subcontractor, are on the convicted vendors list maintained by the Florida Department of Management Services pursuant to Section 287.133(3)(d), F.S.

- i. **Convicted Vendor List.** Pursuant to Subsection 287.133(2)(a), F.S., a person or affiliate who has been placed on the convicted vendor list following a conviction for a public entity crime may not be awarded or perform work as a Grantee, supplier, subcontractor or consultant under a contract with any public entity and may not transact business with any public entity in excess of the threshold amount provided in Section 287.017, F.S., for Category Two for a period of thirty-six (36) months from the date of being placed on the convicted vendor list. The State of Florida, Department of Management Services, Division of State Purchasing provides listings for convicted, suspended, discriminatory and federal excluded parties, as well as the vendor complaint list at:

http://www.dms.myflorida.com/business_operations/state_purchasing/vendor_information/convicted_suspended_discriminatory_complaints_vendor_lists

- ii. **Notice of Conviction of Public Entity Crime.** Any person must notify the Department of Management Services and the Commission, in writing, within thirty (30) days after conviction of a public entity crime applicable to that person or an affiliate of that person as defined in Section 287.133, F.S.

C. Vendors on Scrutinized Companies List.

- i. **Scrutinized Companies.** Grantee certifies that it and any of its affiliates are not scrutinized companies as identified in Section 287.135, F.S. In addition, Grantee agrees to observe the requirements of Section 287.135, F.S., for applicable sub-agreements entered into for the performance of work under this Agreement. Pursuant to Section 287.135, F.S., the Commission may immediately terminate this Agreement for cause if the Grantee, its affiliates, or its subcontractors are found to have submitted a false certification; or if the Grantee, its affiliates, or its subcontractors are placed on any applicable scrutinized companies list or engaged in prohibited contracting activity during the term of the Agreement. As provided in Subsection 287.135(8), F.S., if federal law ceases to authorize these contracting prohibitions then they shall become inoperative.

- D. **Discriminatory Vendors.** Grantee shall disclose to the Commission, in writing, if they, their subrecipient, contractor, or subcontractor, are on the Discriminatory Vendor List maintained by the Florida Department of Management Services pursuant to Section 287.134(3)(d), F.S. "An entity or affiliate who has been placed on the discriminatory vendor list may not submit a bid, proposal, or reply on a contract to provide any goods or services to a public entity; may not submit a bid, proposal, or reply on a contract with a public entity for the construction or repair of a public building or public work; may not submit bids, proposals, or replies on leases of real property to a public entity; may not be awarded or perform work as a contractor, supplier, subcontractor, or consultant under a contract with any public entity; and may not transact business with any public entity." Section 287.134(2)(a), F.S. Grantee has a continuing duty to disclose to the Commission whether they appear on the discriminatory vendor list.

- E. **Prompt Disclosure of Litigation, Investigations, Arbitration, or Administrative Proceedings.** Throughout the term of the Agreement, the Grantee has a continuing duty to promptly disclose to the Commission's Grant Manager, in writing, upon occurrence, all civil or criminal litigation, investigations, arbitration, or administrative proceedings (Proceedings) relating to or affecting the Grantee's ability to perform under this agreement. If the existence of such Proceeding causes the

Commission concern that the Grantee's ability or willingness to perform the Agreement is jeopardized, the Grantee may be required to provide the Commission with reasonable assurances to demonstrate that: a.) the Grantee will be able to perform the Agreement in accordance with its terms and conditions; and, b.) Grantee and/or its employees or agents have not and will not engage in conduct in performing services for the Commission which is similar in nature to the conduct alleged in such Proceeding.

- F. Certain Violations of Federal Criminal Law.** If this agreement includes a Federal award, then in accordance with Section 200.113, OMB Uniform Guidance (2 CFR 200), Grantee must disclose, in a timely manner, in writing to the Commission all violations of Federal criminal law involving fraud, bribery, or gratuity violations potentially affecting the Federal award.

16. INSURANCE.

The Grantee warrants and represents that it is insured, or self-insured for liability insurance, in accordance with applicable state law and that such insurance or self-insurance offers protection applicable to the Grantee's officers, employees, servants and agents while acting within the scope of their employment with the Grantee.

17. SPONSORSHIP.

As required by Section 286.25, F.S., if any recipient, subrecipient, contractor or subcontractor under this grant is a nongovernmental organization which sponsors a program financed wholly or in part by state funds, including any funds obtained through this Agreement, it shall, in publicizing, advertising, or describing the sponsorship of the program, state: "Sponsored by (Grantee's name) and the State of Florida, Fish and Wildlife Conservation Commission." If the sponsorship reference is in written material, the words "State of Florida, Fish and Wildlife Conservation Commission" shall appear in the same size letters or type as the name of the Grantee's organization. Additional sponsorship requirements may be specified in Attachment A, Scope of Work.

18. PUBLIC RECORDS.

- A. All records in conjunction with this Grant shall be public records and shall be treated in the same manner as other public records that are under Chapter 119, F.S.
- B. This Agreement may be unilaterally canceled by the Commission for refusal by the Grantee to allow public access to all documents, papers, letters, or other material subject to the provisions of Chapter 119, F.S., and made or received by the Grantee in conjunction with this Agreement, unless exemption for such records is allowable under Florida law.
- C. If the Grantee meets the definition of "Contractor" in Section 119.0701(1)(a) F.S., the Grantee shall comply with the following:

- i. **IF THE CONTRACTOR HAS QUESTIONS REGARDING THE APPLICATION OF THE CHAPTER 119, FLORIDA STATUTES, TO THE CONTRACTOR'S DUTY TO PROVIDE PUBLIC RECORDS RELATING TO THIS CONTRACT, CONTACT THE CUSTODIAN OF PUBLIC RECORDS AT: 850-488-6553, RecordsCustodian@myfwc.com, and 620 South Meridian Street, Tallahassee FL 32399**

- ii. Keep and maintain public records required by the Commission to perform the service.
- iii. Upon request from the Commission's custodian of public records, provide the Commission with a copy of the requested records or allow the records to be inspected or copied within a reasonable time at a cost that does not exceed the cost provided in Chapter 119, F.S. or as otherwise provided by law.
- iv. Ensure that public records that are exempt or confidential and exempt from public records disclosure requirements are not disclosed except as authorized by law for the duration of the contract term and following completion of the contract if the Contractor does not transfer the records to the Commission.
- v. Upon completion of the contract transfer, at no cost, to the Commission all public records in possession of the Contractor or keep and maintain public records required by the Commission to perform the service. If the Contractor transfers all public records to the Commission upon completion of the contract, the Contractor shall destroy any duplicate public records that are exempt or confidential and exempt from public records disclosure requirements. If the Contractor keeps and maintains public records upon completion of the contract, the Contractor shall meet all applicable requirements for retaining public records. All records stored electronically must be provided to the Commission, upon request from the Commission's custodian of public records, in a format that is compatible with the information technology systems of the Commission.

19. COOPERATION WITH INSPECTOR GENERAL.

Pursuant to subsection 20.055(5), F.S., Grantee, and any subcontractor to the Grantee, understand and will comply with their duty to cooperate with the Inspector General in any investigation, audit, inspection, review, or hearing. Upon request of the Inspector General or any other authorized State official, the Grantee shall provide any type of information the Inspector General deems relevant to the Grantee's integrity or responsibility. Such information may include, but shall not be limited to, the Grantee's business or financial records, documents, or files of any type or form that refer to or relate to the Agreement. The Grantee agrees to reimburse the State for the reasonable costs of investigation incurred by the Inspector General or other authorized State official for investigations of the Grantee's compliance with the terms of this or any other agreement between the Grantee and the State which results in the suspension or debarment of the Grantee. Such costs shall include but shall not be limited to: salaries of investigators, including overtime; travel and lodging expenses; and expert witness and documentary fees.

20. SECURITY AND CONFIDENTIALITY.

The Grantee shall not divulge to third parties any clearly marked confidential information obtained by the Grantee or its agents, distributors, resellers, subcontractors, officers or employees in the course of performing Grant work. To ensure confidentiality, the Grantee shall take appropriate steps regarding its personnel, agents, and subcontractors. The warranties of this paragraph shall survive the Grant.

21. RECORD KEEPING REQUIREMENTS.

- A. **Grantee Responsibilities.** The Grantee shall maintain accurate books, records, documents and other evidence that sufficiently and properly reflect all direct and indirect costs of any nature expended in the performance of this Agreement, in accordance with generally accepted accounting principles.
- B. **State Access to Grantee Books, Documents, Papers, and Records.** The Grantee shall allow the Commission, the Chief Financial Officer of the State of Florida, the Auditor General of the State of Florida, the Florida Office of Program Policy Analysis and Government Accountability or authorized representatives of the state or federal government to have access to any of the Grantee's books, documents, papers, and records, including electronic storage media, as they may relate to this

Agreement, for the purposes of conducting audits or examinations or making excerpts or transcriptions.

- C. **Grantee Records Retention.** Unless otherwise specified in the Scope of Work, these records shall be maintained for five (5) fiscal years following the close of this Agreement, or the period required for this particular type of project by the General Records Schedules maintained by the Florida Department of State (available at: <http://dos.myflorida.com/library-archives/records-management/general-records-schedules/>), whichever is longer. Grantee shall cooperate with the Commission to facilitate the duplication and transfer of such records upon the Commission's request.
- D. **Grantee Responsibility to Include Records Requirements – Subcontractors.** In the event any work is subcontracted under this Agreement, the Grantee shall include the aforementioned audit and record keeping requirements in all subsequent contracts.
- E. **Compliance with Federal Funding Accountability and Transparency.** Any federal funds awarded under this Agreement must comply with the Federal Funding Accountability and Transparency Act (FFATA) of 2006. The intent of the FFATA is to empower every American with the ability to hold the government accountable for each spending decision. The result is to reduce wasteful spending in the government. The FFATA legislation requires that information on federal awards (federal financial assistance and expenditures) be made available to the public via a single, searchable website: <http://www.USASpending.gov>. Grant recipients awarded a new Federal grant greater than or equal to \$25,000.00 awarded on or after October 1, 2010 are subject to the FFATA. The Grantee agrees to provide the information necessary, over the life of this Agreement, for the Commission to comply with this requirement.

22. FEDERAL AND FLORIDA SINGLE AUDIT ACT REQUIREMENTS.

Pursuant to the FSAA (or Federal) Vendor / Recipient Determination Checklist, the Grantee has been determined to be a recipient of state financial assistance and/or a subrecipient of a federal award. Therefore, pursuant to Section 215.97, F.S. and/or OMB Uniform Guidance (2 CFR 200), the Grantee may be subject to the audit requirements of the Florida and/or Federal Single Audit Acts. If applicable, the Grantee shall comply with the audit requirements outlined in Attachment B, "Requirements of the Federal and Florida Single Audit Acts," attached hereto and made a part of the Agreement, as applicable.

23. FEDERAL COMPLIANCE.

As applicable, Grantee shall comply with all federal laws, rules, and regulations, including but not limited to:

- i. **Clean Air Act and Water Pollution Control Act.** All applicable standards, orders, or requirements issued under the Clean Air Act (42 U.S.C. 7401-7671q), and the Water Pollution Control Act (33 U.S.C. 1251-1387, as amended).
- ii. **Lacey Act, 16 U.S.C 3371-3378.** This Act prohibits trade in wildlife, fish and plants that have been illegally taken, possessed, transported or sold.
- iii. **Magnuson-Stevens Fishery Conservation and Management Act, 16 U.S.C. 1801-1884.** This Act governs marine fisheries in Federal waters.
- iv. **Migratory Bird Treaty Act, 16 U.S.C. 703-712.** The Act prohibits anyone, unless permitted, to pursue, hunt, take, capture, kill, attempt to take, capture or kill, possess, offer for sale, sell, offer to purchase, deliver for shipment, ship, cause to be shipped, deliver for transportation, transport, cause to be transported, carry or cause to be carried by any means

whatsoever, receive for shipment, transport of carriage, or export, at any time, or in any manner, any migratory bird, or any part, nest, or egg of such bird.

- v. **Endangered Species Act, 16 U.S.C. 1531, et seq.** The Act provides a program for the conservation of threatened and endangered plants and animals and the habitat in which they are found. The Act also prohibits any action that cause a "taking" of any listed species of endangered fish or wildlife. Also, generally prohibited are the import, export, interstate, and foreign commerce of listed species.

24. FEDERAL FUNDS. ~~This Agreement relies on federal funds, therefore, the following terms and conditions apply.~~

- A. Prior Approval to Expend Federal Funds to Federal Agency or Employee.** It is understood and agreed that the Grantee is not authorized to expend any federal funds under this Contract to a federal agency or employee without the prior written approval of the awarding federal agency.
- B. Equal Employment Opportunity.** Executive Order 11246 of September 24, 1965, entitled "Equal Employment Opportunity," as amended by Executive Order 11375 of October 13, 1967, and as supplemented in Department of Labor regulations (41 CFR Chapter 60). Applicable, except as otherwise provide under 41 CFR Part 60, to any grant, contract, loan, insurance, or guarantee involving Federal assisted construction.
- C. Davis-Bacon Act.** The Davis-Bacon Act, 40 U.S.C. 3141-3148, as supplemented by Department of Labor regulations at 29 CFR Part 5. Applicable to contractors and subcontractors performing on federally funded or assisted contracts in excess of \$2,000.00 for the construction, alteration, or repair (including painting and decorating) of public buildings or public works. Under this Act, contractors and subcontractors must pay their laborers and mechanics employed under the contract no less than the locally prevailing wages and fringe benefits for corresponding work on similar projects in the area.
- D. Copeland "Anti-Kickback Act."** The Copeland "Anti-Kickback" Act, 40 U.S.C. 3141-3148, and 3146-3148, as supplemented by Department of Labor regulations (29 CFR Part 5). Applicable to contracts awarded by a non-Federal entity in excess of \$100,000.00 that involve employment of mechanics or laborers. Under this Act, contractors and subrecipients are prohibited from inducing, by any mean, any person employed in the construction, completion, or repair of public work, to give up any part of the compensation to which he or she is otherwise entitled.
- E. Contract Work Hours and Safety Standards Act.** Sections 103 and 107 of the Agreement Work Hours and Safety Standards Act (40 U.S.C. 327-330) as supplemented by Department of Labor regulations (29 CFR part 5). Applicable to construction contracts awarded by Contractors and subcontractors in excess of \$2,000.00, and in excess of \$2,500.00 for other contracts which involve the employment of mechanics or laborers. Under this Act, contractors and subcontractors must compute wages of mechanics and laborers (workers) on the basis of a standard forty (40) hour work week; provide workers no less than time and a half for hours worked in excess of the forty (40) hour work week; and not require workers to work in surroundings or work conditions that are unsanitary, hazardous, or dangerous.
- F. Rights to Inventions Made Under a Contract or Agreement.** 37 CFR Part 401. If the Federal award meets the definition of "funding agreement" under 37 CFR 401.2(a) and the recipient or Subrecipient wishes to enter into a contract with a small business firm or nonprofit organization regarding the substitution of parties, assignment or performance of experimental, developmental, or research work under the "funding agreement," the recipient or subrecipient must comply with the requirements of 37 CFR Part 401, "Rights to Inventions Made by Nonprofit Organizations and Small Business Firms

Under Government Grants, Contracts and Cooperative Agreements," and any implementing regulations issued by the awarding agency.

- G. Energy Efficiency.** Mandatory standards and policies relating to energy efficiency which are contained in the State energy conservation plan issued in compliance with the Energy Policy and Conservation Act (Pub. L. 94-163, 89 Stat. 871).
- H. Debarment and Suspension Contractor Federal Certification.** In accordance with Federal Executive Order 12549 and 2 CFR Part 1400 regarding Debarment and Suspension, the Grantee certifies that neither it, nor its principals, is presently debarred, suspended, proposed for debarment, declared ineligible, or voluntarily excluded from participation in this transaction by any federal department or agency; and, that the Grantee shall not knowingly enter into any lower tier contract, or other covered transaction, with a person who is similarly debarred or suspended from participating in this covered transaction.
- I. Prohibition against Lobbying.**
- i. **Grantee Certification – Payments to Influence.** The Grantee certifies that no Federal appropriated funds have been paid or will be paid, on or after December 22, 1989, by or on behalf of the Grantee, to any person for influencing or attempting to influence an officer or employee of an agency, a Member of Congress, an officer or employee of Congress, or an employee of a Member of Congress, in connection with the awarding, renewal, amending or modifying of any Federal contract, grant, or cooperative agreement. The Grantee also certifies that they have not engaged any registrant under the Lobbying Disclosure Act of 1995 who has made lobbying contacts on behalf of the Grantee with respect to this Contract and its related federal contract, grant, loan, or cooperative agreement; or, if the Grantee has engaged any registrant with respect to this Contract and its related Federal contract, grant, loan, or cooperative agreement, the Grantee shall, prior to or upon execution of this Contract, provide the Commission Contract Manager a signed declaration listing the name of any said registrant. During the term of this Contract, and at the end of each Calendar quarter in which any event occurs that materially affects the accuracy of this certification or declaration, the Grantee shall file an updated declaration with the Commission's Contract Manager. If any non-federal funds are used for lobbying activities as described above in connection with this Contract, the Grantee shall submit Standard Form-LLL, "Disclosure Form to Report Lobbying", and shall file quarterly updates of any material changes. The Grantee shall require the language of this certification to be included in all subcontracts, and all subcontractors shall certify and disclose accordingly.
 - ii. **Grantee – Refrain from Subcontracting with Certain Organizations.** Pursuant to the Lobbying Disclosure Act of 1995, the Grantee agrees to refrain from entering into any subcontracts under this Contract with any organization described in Section 501(c)(4) of the Internal Revenue Code of 1986, unless such organization warrants that it does not, and will not, engage in lobbying activities prohibited by the Act as a special condition of the subcontract.
- J. Compliance with Office of Management and Budget Circulars.** As applicable, Grantee shall comply with the following Office of Management and Budget (OMB) Uniform Guidance (2 CFR 200).
- K. Drug Free Workplace.** Pursuant to the Drug-Free Workplace Act of 1988, the Grantee attests and certifies that the Grantee will provide a drug-free workplace compliant with 41 U.S.C. 81.

25. CONTRACT-RELATED PROCUREMENT.

- A. PRIDE.** In accordance with Section 946.515(6), F.S., if a product or service required for the performance of this Contract is certified by or is available from Prison Rehabilitative Industries and Diversified Enterprises, Inc. (PRIDE) and has been approved in accordance with Subsection 946.515(2), F.S., the following statement applies:

It is expressly understood and agreed that any articles which are the subject of, or required to carry out, this contract shall be purchased from [PRIDE] in the same manner and under the same procedures set forth in Subsections 946.515(2) and (4), F.S.; and for purposes of this contract the person, firm or other business entity carrying out the provisions of this contract shall be deemed to be substituted for this agency insofar as dealings with such corporation are concerned.

The above clause is not applicable to subcontractors unless otherwise required by law. Additional information about PRIDE and the products it offers is available at <http://www.pride-enterprises.org>.

- B. Respect of Florida.** In accordance with Subsection 413.036(3), F.S., if a product or service required for the performance of this Contract is on the procurement list established pursuant to Subsection 413.035(2), F.S., the following statement applies:

It is expressly understood and agreed that any articles that are the subject of, or required to carry out, this contract shall be purchased from a nonprofit agency for the blind or for the severely handicapped that is qualified pursuant to Chapter 413, F.S., in the same manner and under the same procedures set forth in Subsections 413.036(1) and (2), F.S.; and for purposes of this contract, the person, firm or other business entity carrying out the provisions of this contract shall be deemed to be substituted for the state agency insofar as dealings with such qualified nonprofit agency are concerned.

Additional information about the designated nonprofit agency and the products it offers is available at <http://www.respectofflorida.org>.

- C. Procurement of Recycled Products or Materials.** Grantee agrees to procure any recycled products or materials which are the subject of or are required to carry out this Contract in accordance with Section 403.7065, F.S.

26. PROFESSIONAL SERVICES.

- A. Architectural, Engineering, Landscape Architectural, or Survey and Mapping.** If this Agreement is for the acquisition of professional architectural, engineering, landscape architectural, or registered surveying and mapping services, and is therefore subject to Section 287.055, F.S., the following provision applies:

The architect (or registered surveyor and mapper or professional engineer, as applicable) warrants that he or she has not employed or retained any company or person, other than a bona fide employee working solely for the architect (or

registered surveyor and mapper, or professional engineer, as applicable) to solicit or secure this Agreement and that he or she has not paid or agreed to pay any person, company, corporation, individual, or firm, other than a bona fide employee working solely for the architect (or registered surveyor and mapper or professional engineer, as applicable) any fee, commission, percentage, gift, or other consideration contingent upon or resulting from the award or making of this contract.

- B. Termination for Breach.** For the breach or violation of this provision, the Commission shall have the right to terminate the Agreement without liability and, at its discretion, to deduct from the Agreement price, or otherwise recover, the full amount of such fee, commission, percentage, gift, or consideration.

27. INDEMNIFICATION.

If Grantee is a state agency or subdivision, as defined in Subsection 768.28(2), F.S., pursuant to Subsection 768.28(19), F.S., neither Party indemnifies nor insures the other Party for the other Party's negligence. If Grantee is not a state agency or subdivision as defined above, Grantee shall be fully liable for the actions of its agents, employees, partners, or subcontractors and shall fully indemnify, defend, and hold harmless the State and the Commission, and their officers, agents, and employees, from suits, actions, damages, and costs of every name and description, including attorneys' fees, arising from or relating to personal injury and damage to real or personal tangible property alleged to be caused in whole or in part by Grantee, its agents, employees, partners, or subcontractors, provided, however, that Grantee shall not indemnify for that portion of any loss or damages proximately caused by the negligent act or omission of the State or the Commission. If this is a Professional Services Agreement as defined in Subsection 725.08 F.S., then notwithstanding the provisions of Subsection 725.06 F.S., the design professional shall only be liable for, and fully indemnify, defend, and hold harmless the State, the Commission, and their officers, agents, and employees, for actions caused in whole or in part, by the negligence, recklessness, or intentionally wrongful conduct of the design professional and other persons employed or utilized by the design professional in the performance of the Agreement.

28. NON-DISCRIMINATION.

No person, on the grounds of race, creed, color, national origin, age, sex, or disability, shall be excluded from participation in, be denied the proceeds or benefits of, or be otherwise subjected to discrimination in performance of this Agreement.

29. SEVERABILITY, CHOICE OF LAW, AND CHOICE OF VENUE.

This Agreement has been delivered in the State of Florida and shall be construed in accordance with the laws of Florida. Wherever possible, each provision of this Agreement shall be interpreted in such manner as to be effective and valid under applicable law, but if any provision of this Agreement shall be prohibited or invalid under applicable law, such provision shall be ineffective to the extent of such prohibition or invalidity, without invalidating the remainder of such provision or the remaining provisions of this Agreement. Any action in connection herewith, in law or equity, shall be brought in Leon County, Florida, to the exclusion of all other lawful venues.

30. NO THIRD-PARTY RIGHTS.

The Parties hereto do not intend, nor shall this Agreement be construed to grant any rights, privileges or interest to any person not a party to this Agreement.

31. JURY TRIAL WAIVER.

As part of the consideration for this Agreement, the Parties hereby waive trial by jury in any action or proceeding brought by any party against any other party pertaining to any matter whatsoever arising out of or in any way connected with this Agreement, or with the products or services provided under this Agreement, including but not limited to any claim by the Grantee of *quantum meruit*.

32. PROHIBITION OF UNAUTHORIZED ALIENS.

In accordance with Federal Executive Order 96-236, the Commission shall consider the employment by the Grantee of unauthorized aliens a violation of Section 274A(e) of the Immigration and Nationalization Act. Such violation shall be cause for unilateral cancellation of this Agreement if the Grantee knowingly employs unauthorized aliens.

33. EMPLOYMENT ELIGIBILITY VERIFICATION (E-VERIFY).

- A. Requirement to Use E-Verify.** Executive Order 11-116, signed May 27, 2011, by the Governor of Florida, requires Commission contracts in excess of nominal value to expressly require the Grantee to: 1.) utilize the U.S. Department of Homeland Security's E-Verify system to verify the employment eligibility of all new employees hired by Grantee during the Agreement term; and, 2.) include in all subcontracts under this Agreement, the requirement that subcontractors performing work or providing services pursuant to this Agreement utilize the E-Verify system to verify the employment eligibility of all new employees hired by the subcontractor during the term of the subcontract.
- B. E-Verify Online.** E-Verify is an Internet-based system that allows an employer, using information reported on an employee's Form I-9, Employment Eligibility Verification, to determine the eligibility of all new employees hired to work in the United States after the effective date of the required Memorandum of Understanding (MOU); the responsibilities and elections of federal contractors, however, may vary, as stated in Article II.D.1.c. of the MOU. There is no charge to employers to use E-Verify. The Department of Homeland Security's E-Verify system can be found online at http://www.dhs.gov/files/programs/gc_1185221678150.shtm
- C. Enrollment in E-Verify.** If Grantee does not have an E-Verify MOU in effect, the Grantee must enroll in the E-Verify system prior to hiring any new employee after the effective date of this Agreement.
- D. E-Verify Recordkeeping.** The Grantee further agrees to maintain records of its participation and compliance with the provisions of the E-Verify program, including participation by its subcontractors as provided above, and to make such records available to the Commission or other authorized state entity consistent with the terms of the Grantee's enrollment in the program. This includes maintaining a copy of proof of the Grantee's and subcontractors' enrollment in the E-Verify Program (which can be accessed from the "Edit Company Profile" link on the left navigation menu of the E-Verify employer's homepage).
- E. Employment Eligibility Verification.** Compliance with the terms of the Employment Eligibility Verification provision is made an express condition of this Agreement and the Commission may treat a failure to comply as a material breach of the Agreement.

34. FORCE MAJEURE AND NOTICE OF DELAY FROM FORCE MAJEURE.

Neither Party shall be liable to the other for any delay or failure to perform under this Agreement if such delay or failure is neither the fault nor the negligence of the Party or its employees or agents and the delay is due directly to acts of God, wars, acts of public enemies, strikes, fires, floods, or other similar cause wholly beyond the Party's control, or for any of the foregoing that affects subcontractors or suppliers if no alternate source of supply is available. However, in the event of delay from the foregoing causes, the Party shall take all reasonable measures to mitigate any and all resulting delay or disruption in the Party's performance obligation under this Agreement. If the delay is excusable under this paragraph, the delay will not result in any additional charge or cost under the Agreement to either Party. In the case of any delay the Grantee believes is excusable under this paragraph, Grantee shall notify the Commission's Grant Manager in writing of the delay or potential delay and describe the cause of the delay either: (1) within ten (10) calendar days after the cause that creates or will create the delay first arose, if Grantee could reasonably foresee that a delay could occur as a result; or (2) within five (5) calendar days after the date Grantee first had reason to believe that a delay could result, if the delay is not reasonably foreseeable. **THE FOREGOING SHALL CONSTITUTE GRANTEE'S SOLE REMEDY OR EXCUSE WITH RESPECT TO DELAY.** Providing notice in strict accordance with this paragraph is a condition precedent to such remedy. The Commission, in its sole discretion, will determine if the delay is excusable under this paragraph and will notify Grantee of its decision in writing. No claim for damages, other than for an extension of time, shall be asserted against the Commission. Grantee shall not be entitled to an increase in the Agreement price or payment of any kind from the Commission for direct, indirect, consequential, impact, or other costs, expenses or damages, including but not limited to costs of acceleration or inefficiency arising because of delay, disruption, interference, or hindrance from any cause whatsoever. If performance is suspended or delayed, in whole or in part, due to any of the causes described in this paragraph, after the causes have ceased to exist, Grantee shall perform at no increased cost, unless the Commission determines, in its sole discretion, that the delay will significantly impair the value of the Agreement to the Commission or the State, in which case, the Commission may do any or all of the following: (1) accept allocated performance or deliveries from Grantee, provided that Grantee grants preferential treatment to the Commission with respect to products or services subjected to allocation; (2) purchase from other sources (without recourse to and by Grantee for the related costs and expenses) to replace all or part of the products or services that are the subject of the delay, which purchases may be deducted from the Agreement quantity; or (3) terminate the Agreement in whole or in part.

35. TIME IS OF THE ESSENCE.

Time is of the essence regarding the performance obligations set forth in this Agreement. Any additional deadlines for performance for Grantee's obligation to timely provide deliverables under this Agreement including but not limited to timely submittal of reports, are contained in the Scope of Work, Attachment A.

36. ENTIRE AGREEMENT.

This Agreement with all incorporated attachments and exhibits represents the entire Agreement of the Parties. Any alterations, variations, changes, modifications or waivers of provisions of this Agreement shall only be valid when they have been reduced to writing, and duly signed by each of the Parties hereto, unless otherwise provided herein. In the event of conflict, the following order of precedence shall prevail; this Agreement and its attachments, the terms of the solicitation and the Grantee's response to the solicitation.

IN WITNESS WHEREOF, the Parties hereto have caused this Agreement to be executed through their duly authorized signatories on the day and year last written below.

Franklin County Board of Commissioners

Florida Fish and Wildlife Conservation Commission

Signature Ricky D. Jones

[Signature]
Executive Director (or designee)

Name: Ricky D. Jones

Name: DAN EUNIK

Title: Chairman

Title: Section Leader

Date: 12/15/2020

Date: 2-4-21

Approved as to form and legality:

/s/ Quilla Miralla
FWC Attorney Signature

Attachments in this Agreement include the following:

- Attachment A Scope of Work
- Attachment B Requirements of the Federal and Florida Single Audit Acts
- Attachment C Federal Aid Compliance Requirements
- Attachment D Cost Reimbursement Contract Payment Requirements
- Attachment E Certification Regarding Debarment/Suspension for Subcontracts
- Attachment F Certification of Completion

Attachment A – SCOPE OF WORK

Project Name:	Franklin County Artificial Reef Construction 2020-21	FWC Agreement No.	20011
----------------------	---------------------------------------------------------	--------------------------	-------

1. DESCRIPTION OF GOODS / SERVICES PROCURED, OR PROJECT WORKPLAN

A. DESCRIPTION OF GOODS / SERVICES

The objective of this activity is to construct a marine artificial reef complex by deploying at least 25 pre-fabricated concrete modules at least four feet tall creating three patch reef within the Buddy Ward permitted area. Each module will be placed at designated locations within the boundaries of the permitted area at a depth of 42 feet.

The artificial reef construction activity to be funded consists of the following elements:

MATERIALS

1. Artificial reef materials must consist of a total of at least 25 pre-fabricated concrete artificial reef modules, or other concrete structures acceptable to the **COMMISSION**. All modules must be at least four (4) feet tall with a base diameter of at least six (6) feet and weigh at least two (2) tons.
2. Pre-fabricated modules must be composed of marine grade concrete with a minimum strength of 4,000 pounds per square inch (psi). Pre-fabricated modules shall consist of concrete with no exposed metal framework. Pre-fabricated modules will be designed with multiple openings of various sizes all the way through the outer surface to allow for water circulation and access by fish.
3. Open-bottom pre-fabricated reef modules may not be used unless the module has a top opening sufficiently large to allow for turtle escapement. Approved open-bottom modules include:
 - a. Three-sided modules where each side of the top opening is at least 36-in in length along its edge.
 - b. Four or more sided modules where each side of the top opening is at least 40-in in length along its edge.
 - c. Modules with a round opening with a diameter of at least 40-in (oval openings are not allowed unless a 40-in diameter circle space can fit within the oval).
 - d. Modules that are approved by the **COMMISSION** as being turtle friendly.
4. No open-bottom modules are allowed that include additional modules, discs, or other materials stacked, placed on or immediately adjacent to the top opening, as they may prevent turtles from easily escaping.
5. All artificial reef materials shall be clean and free from dirt, asphalt, creosote, petroleum, or other hydrocarbons and toxic residues, loose free floating material or other deleterious substances.
6. The **GRANTEE** shall evaluate the structural integrity of each pre-fabricated module proposed for use, and shall eliminate from artificial reef material consideration all badly damaged modules that would be prone to break apart during the transport and/or deployment process.

Attachment A – SCOPE OF WORK

Project Name:	Franklin County Artificial Reef Construction 2020-21	FWC Agreement No.	20011
----------------------	-----------------------------------------------------------------	--------------------------	--------------

7. For each barge load of artificial reef materials, the **GRANTEE** shall inventory all of the artificial reef materials, calculate the tonnage (either using before and after barge draft calculations, trucking receipts, or the known weights of individual pieces or reef modules), and take a representative photograph of the artificial reef material on the barge or other deployment vessel immediately prior to deployment.
8. The **GRANTEE** must develop for the purpose of tracking each module placement a system of unique module identifiers. For example, one such system could consist of unique alpha numeric lettering spray painted or otherwise obviously displayed on each unit. The purpose of this system is to allow for visual identification of these units underwater during initial post deployment module condition and orientation visual assessments.
9. Units must be capable of being deployed in an upright position on the seafloor. Any lifting lines or straps used during deployment must be temporary and removed by the **GRANTEE** prior to reimbursement.
10. Reimbursement for loading, transporting and deploying the materials will be based on cost per unit basis. Materials that are placed within the boundaries of the permitted area, completely intact and in an upright position will be reimbursed at the full unit cost. Materials that are damaged during loading, transport or deployment operations will be reimbursed based on the liquidated damage schedule (if applicable) listed in the bid specifications provided by the **GRANTEE** and approved by the **COMMISSION**.
11. The **GRANTEE** agrees to allow the **COMMISSION** to conduct on-site inspections of the artificial reef materials before, during, and after the deployment.

LOADING AND TRANSPORTATION

12. Artificial reef materials will be loaded using a suitable means of conveyance for transportation to a staging area site and loading onto a barge or other suitable vessel for offshore transportation to the designated artificial reef site. Offshore transportation shall be provided by a sufficiently powered transport or towing vessel, and shall include the necessary personnel and equipment to safely transport and deploy the reef material. Reef material loaded on to the transporting vessel must be properly secured in compliance with Coast Guard standards to allow for its safe transport to the reef construction site.
13. The **GRANTEE's** Project Manager shall complete the FWC Artificial Reef Cargo Manifest form to be maintained onboard the vessel at all times during transport of materials, pursuant to Chapter 379.249, F.S. The form is available on the **COMMISSION's** website: <http://www.myfwc.com/artificialreefs>.

DEPLOYMENT AND MATERIALS PLACEMENT

14. During the deployment of the artificial reef material, the transport vessel must be securely in place with minimal movement (<50 feet) to ensure accurate placement of

Attachment A – SCOPE OF WORK

Project Name:	Franklin County Artificial Reef Construction 2020-21	FWC Agreement No.	20011
----------------------	---------------------------------------------------------	--------------------------	-------

each concrete module on the bottom. Material must be arranged to provide habitat complexity as well as provide sand bottom forage area opportunities.

15. Any machinery used to move and deploy the reef materials should be sufficiently powered/maneuverable and capably operated to ensure timely, effective and safe off-loading of materials. The tug or transport vessel shall meet all U.S. Coast Guard certification and safety requirements, be equipped with a working, accurate Global Positioning System (GPS) unit and other marine electronics including a working VHF radio. Effective and reliable communications shall exist at all times between the transport vessel, and the designated **GRANTEE** observer on site.
16. Deployment operations will only be initiated when sea height in the operations area is no greater than two to four feet as forecast by the nearest NOAA weather office. Either the **COMMISSION'S** observer, the **GRANTEE's** observer or the subcontractor's vessel captain reserves the right to suspend off-loading operations if positioning and other deployment objectives, including safety of personnel and equipment, are not being met.
17. At least 25 pre-fabricated reef modules under this Agreement will strategically placed to create three patch reefs within the Buddy Ward permitted area at the coordinates listed in Table 1. Pre-fabricated reef modules will be carefully spaced at least ten feet apart and no more than 50 feet apart to avoid potential damage while still providing one cohesive patch reef.

Table 1

Patch Reef #	Latitude	Longitude
1	29° 29.144'N	84° 56.031'W
2	29° 29.144'N	84° 55.763'W
3	29° 29.144'N	84° 55.494'W

18. The minimum vertical clearance of 25 feet shall be maintained above the highest point of the reef material in the Buddy Ward permitted site (in accordance with the special conditions of the US Army Corps of Engineers permit number SAJ-2018-02268.
19. The **GRANTEE** shall provide a bottom survey for **COMMISSION** review and approval at least 14 days prior to deployment. The bottom survey must be a visual site survey completed by certified SCUBA divers. The entire extent of the proposed patch reef area(s) must be surveyed during the dive(s). The **GRANTEE** will submit a narrative of the survey methods, results and photo documentation of the bottom.
20. The **GRANTEE's** Contract Manager or **GRANTEE's** designated official observer shall oversee the temporary marking of the reef deployment location in advance of reef materials deployment in order to assist the subcontractor in the proper placement of the artificial reef materials. The marker(s) shall be buoys of sufficient size and color to be clearly visible to the tug captain, and sufficiently anchored and with sufficient scope

Attachment A – SCOPE OF WORK

Project Name:	Franklin County Artificial Reef Construction 2020-21	FWC Agreement No.	20011
----------------------	---------------------------------------------------------	--------------------------	-------

so that they will not drift off the designated deployment site prior to deployment. The **COMMISSION** will not pay for materials placed outside the permit area as described above. Precise GPS placement of marker buoys that do not shift position with time are important to ensure the reef is constructed within the permitted area.

21. The **GRANTEE's** Project Manager or **GRANTEE's** designated official observer shall remain on site during the entire deployment phase of the operation and confirm the GPS coordinates of the individual placements as well as the maximum vertical relief of the constructed reefs using a fathometer after the reef construction has been completed.
22. Both the **GRANTEE** and its subcontractor shall have on site current nautical charts of the deployment area, with the permitted site indicated on the chart. The proposed patch reef coordinates and the corner coordinates of the reef site will also be in possession of the **GRANTEE's** observer and the subcontractor when on site. The **GRANTEE's** observer shall also be in possession of a copy of the Army Corps permit for the area where the deployments are taking place. The **GRANTEE** shall be responsible for ensuring that all permit condition terms are complied with.
23. Both the **GRANTEE** and its subcontractor shall be prepared to remove any floating debris that might occur during deployment. Having boat hooks, dip nets, and other equipment on board to enable efficient collection of unanticipated floating debris is strongly encouraged. The **GRANTEE** shall be responsible for ensuring that any floating debris discovered during deployment operations (e.g., wood, floating line, aluminum cans, plastic bottles, or other floating materials) shall be collected and transported back to land for proper disposal.

ALLOWABLE EXPENDITURES ASSOCIATED WITH THE REEF PROJECT

24. Funds from this Agreement may be expended on the activities listed pursuant to Chapter 68E-9.004(1)(a), F.A.C. No more than \$5,000 or 10% (whichever is less) of project funds granted under the program may be expended for 'engineering services'. Any funds required in excess of this amount must be provided by the applicant. See Chapter 68E-9.004(1)(a), F.A.C. for the definition of 'engineering services' and complete list of eligible materials and activities.
25. If the **GRANTEE** chooses to conduct a post-deployment SCUBA assessment at the deployment location(s) (post-deployment assessment is not required, but is an eligible activity for reimbursement under Chapter 68E-9.004(1)(a), F.A.C.), in order to be eligible for reimbursement, work must be completed within the current grant period and the following items, at a minimum, must be included:
 - a. *Methods*: name and type of vessel, anchored or live boated, type of GPS unit(s), divers, survey methods;
 - b. *Conditions*: cloud cover, wind speed and direction, sea conditions, visibility, water temperature, currents;
 - c. *Chronology*: dive plan, start and end of each dive, dive profile, maximum depth, dive time, distance and bearing searched;
 - d. *Coordinates*: Describe the GPS unit(s) used to navigate to the site (model number). Describe whether differential or WAAS coordinates were recorded. Compare the

Attachment A – SCOPE OF WORK

Project Name:	Franklin County Artificial Reef Construction 2020-21	FWC Agreement No.	20011
----------------------	---------------------------------------------------------	--------------------------	-------

- dive locations to deployment location numbers. How well do they match the published numbers?
- e. *Physical observations:* Describe the number and size of material observed. What is the proximity of concrete pieces or modules to each other? What percent material was damaged or partially damaged? What is the maximum and minimum relief of the site? How do these observations compare to the Material Placement Report Form information submittal?
 - f. *Footprint area:* Measure the approximate total area covered by each patch reef through standard in situ survey practices.
 - g. *Biological observations:* Describe any fish observed, or other general biological observations.
 - h. *Video and photographs:* Provide representative still and/or video footage of each deployment location (digital format preferred when available).

LIABILITY AND RESPONSIBILITY FOR REEF MATERIALS

- 26. Upon initiation of the handling and movement of these artificial reef materials by the GRANTEE's subcontractor, all liability, risk of loss and responsibility for the safe handling, storage, transportation and deployment of the materials shall be borne by the subcontractor. This liability, assumption of risk and responsibility shall remain with the subcontractor until the materials are deployed at the permitted reef site in accordance with the specifications in this Agreement.

B. BACKGROUND

Chapter 379.249 F.S. creates the Florida Artificial Reef Program to enhance saltwater opportunities and to promote proper management of fisheries resources associated with artificial reefs for the public interest. Under the program, the COMMISSION may provide grants and financial and technical assistance to coastal local governments, state universities, and nonprofit corporations qualified under s. 501(c)(3) of the Internal Revenue Code for the siting and development of artificial reefs as well as for monitoring and evaluating such reefs and their recreational, economic, and biological effectiveness. Chapter 68E-9 F.A.C defines the procedures for submitting an application for financial assistance and criteria for allocating available funds. The purpose of this rule is to govern the development of state and federally funded artificial reefs, the review and ranking of project applications eligible for funding, and the administration of funds from the Florida Artificial Reef Program.

This artificial reef construction project was selected for funding by the COMMISSION based upon ranking of competitive applications submitted to the Artificial Reef Program pursuant to the criteria for allocating funds described in Chapter 68E-9, F.A.C.

C. SUPPORT OF COMMISSION MISSION

Construction of this artificial reef will augment marine hard bottom habitat with well-planned stable and durable artificial reefs for purposes of providing near shore reef fish habitat, offshore recreational fishing and diving opportunities, reduced pressure on natural reef and hard bottom sites, and reduced user conflicts by providing additional recreational fishing and diving site

Attachment A – SCOPE OF WORK

Project Name:	Franklin County Artificial Reef Construction 2020-21	FWC Agreement No.	20011
----------------------	---------------------------------------------------------	--------------------------	-------

locations off of Florida's coastal waters. The proposed artificial reefs will make fisheries resources available for the long term benefit of local Florida residents and visitors.

D. DEFINITIONS

The terms and abbreviations used herein shall have the meanings as defined below.

- i. "Artificial reef" means one or more manufactured or natural objects intentionally placed on the bottom in predominantly marine waters to provide conditions believed to be favorable in sustaining, or enhancing the spawning, breeding, feeding, or growth to maturity of Florida's managed reef associated fish species as well as to increase the productivity of other reef community resources which support fisheries. Included in this definition are artificial reefs developed with one or more of the following additional objectives: enhancement of fishing and diving opportunities, fisheries research, and fisheries conservation/preservation purposes.
- ii. "Permitted area" means an area with discrete boundaries inside of which one or more artificial reefs may be located and for which all required permits and authorizations have been obtained. These permits and authorizations include: artificial reef permits issued by the Florida Department of Environmental Protection and/or the Army Corps of Engineers and other permits, licenses, or authorizations required by any governing body.
- iii. "Staging area" means a land-based holding area for artificial reef material where such material is stored and prepared for transportation to an approved artificial reef site.
- iv. "Prefabricated modules" means structures specifically designed and built for use as artificial reefs and which meet the environmental safety, durability, and stability requirements of this rule, as well as providing complexity and texture which are suitable as habitat for fishes and for colonization by encrusting marine organisms.
- v. "Base diameter" means the longest distance formed with a straight line between two edges or corners through the center of the module, when viewed from above.

2. DELIVERABLES

A. Deliverable #1 (Artificial Reef Construction)

Construction of a marine artificial reef by deploying at least 25 pre-fabricated concrete reef modules within the Buddy Ward permitted area. Pre-fabricated modules will be placed in close proximity to each other to create three patch reef within the boundaries of the permitted area.

i. Minimum Level of Performance

The artificial reef must be deployed within the boundaries of the permitted area and in compliance with all the applicable permits and authorizations associated with the permitted area. At a minimum, a total of at least 25 pre-fabricated concrete reef modules must be deployed in accordance with the specifications in this Agreement.

Attachment A – SCOPE OF WORK

Project Name:	Franklin County Artificial Reef Construction 2020-21	FWC Agreement No.	20011
----------------------	---------------------------------------------------------	--------------------------	-------

ii. Documentation / Criteria Used as Evidence of Performance

1. A Materials Placement Report shall be submitted to the **COMMISSION's** Project Manager within 30 days of field operations completion. The Materials Placement Report form is available on the **COMMISSION's** website at <http://www.myfwc.com/artificialreefs>. The Materials Placement Report must have a certification signature and reflect an accurate material tonnage for the reef deployed as well as a detailed description of the type, number, dimensions and individual weights of the various sizes of reef materials deployed. This information may be submitted on the materials placement report in lieu of taking loaded and unloaded barge measurements. If accurate individual weights of concrete units cannot be obtained or are not known, barge displacement measurements are required. The **GRANTEE's** Project Manager or **GRANTEE's** designee shall then record the waterline length, width and draft (to the nearest inch) of the loaded barge at all four (4) corners to calculate the average displacement of water due to the weight of the artificial reef materials. The same barge measurements must be taken by either the **GRANTEE's** Project Manager or **GRANTEE's** designee when the barge returns to shore after the deployment has been completed. These measurements may not be taken while the barge is offshore at the deployment site. The barge measurements are to be included in the Materials Placement Report.
2. A table providing coordinates for each deployed module is required and is to be attached to the Material Placement Report. Coordinates can be reported by the contracted vendor during deployment or by the **GRANTEE** during post-deployment monitoring.
3. A final written field assessment providing the designated observer's narrative, for each day of the reef deployment operations, is required prior to reimbursement. The field report shall include a written chronology and narrative describing the deployment, and a performance evaluation of the marine subcontractors who performed the work. The final field assessment should include photos of the material and loaded barge prior to each deployment and, if available, underwater photographs and video footage (surface and/or underwater).

iii. Timeline for Completion

All artificial reef construction must be completed by August 1, 2021. A one-time short term time extension of up to thirty (30) days (through the Agreement end date of August 31, 2021) may be authorized in writing by the **COMMISSION's** Contract Manager under the following conditions: a) documented hazardous weather and sea conditions do not allow for the safe deployment of reef materials offshore or, b) unanticipated documented equipment malfunction on the transport vessel or accompanying tug or at the shore-side loading area results in an unexpected short term delay. The **COMMISSION** reserves the right to deny any time extension request if

Attachment A – SCOPE OF WORK

Project Name:	Franklin County Artificial Reef Construction 2020-21	FWC Agreement No.	20011
----------------------	---------------------------------------------------------	--------------------------	-------

sufficient progress has not been accomplished. Advance planning that avoids dependence on a favorable weather window during the final days of the project is strongly encouraged. All request for bid packages from the **GRANTEE** to subcontractors must include language that specifies a completion date that ensures all materials will be in the water by August 1, 2021. Subcontracts with completion dates even earlier than August 1, 2021 to provide an additional buffer are strongly encouraged.

3. FINANCIAL CONSEQUENCES

- A. If the **GRANTEE** fails to complete construction in compliance with the permit conditions or in accordance with the time frame and minimum level of performance specified by the Scope of Work. The percentage deducted from the total reimbursement will be the proportion of incomplete units (number of units not completed divided by the total number of proposed units).
- B. The **GRANTEE** will not be eligible for reimbursement until all reports have been provided to the satisfaction of the **COMMISSION** documenting that all work has been completed in accordance with the Scope of Work, and in compliance with all permit conditions.

4. PERFORMANCE

- A. The **GRANTEE** shall submit to the **COMMISSION**, at no less than 60 day intervals beginning from the date of execution of this agreement, written or electronically transmitted progress reports outlining the progress of the project. The progress report shall identify any problems that may have arisen and actions taken to correct such problems, and include construction activities that have occurred since the last report and construction activities planned until the next report.
- B. The **GRANTEE** agrees to provide the **COMMISSION** with a minimum of five (5) days' notice and continuous notification as each deployment date approaches for any artificial reef construction that occurs as a result of this Agreement.
- C. The **GRANTEE** agrees to follow all provisions of Section 379.249, F.S. and Chapter 68E-9, F.A.C. during the term of this Agreement.
- D. The **GRANTEE** agrees to comply with all applicable federal, state, and local statutes, rules and regulations in providing goods or services to the **COMMISSION** under the terms of this Agreement; including the general and special conditions specified in any permits issued by the Department of the Army, Corps of Engineers and/or the Florida Department of Environmental Protection. The **GRANTEE** further agrees to include this as a separate provision in all subcontracts issued as a result of this Agreement.
- E. If prehistoric or historic artifacts, such as pottery or ceramics, projectile points, dugout canoes, metal implements, historic building material, or any other physical remains that could be associated with Native American, early European, or American settlement are encountered at any time within the project site area, the permitted project shall cease all activities involving

Attachment A – SCOPE OF WORK

Project Name:	Franklin County Artificial Reef Construction 2020-21	FWC Agreement No.	20011
----------------------	---------------------------------------------------------	--------------------------	-------

subsurface disturbance in the immediate vicinity of the discovery. The applicant shall contact the Florida Department of State, Division of Historical Resources, Compliance Review Section at (850)245-6333. Project activities shall not resume without verbal and/or written authorization. In the event that unmarked human remains are encountered during the permitted activities, all work shall stop immediately and the proper authorities notified in accordance with Section 872.05, F.S.

- F. Funds from this Agreement may not be expended on salaries, training, or parts replacement or repairs to rented or contractor owned equipment. Documentation of expenses and survey reports must be submitted with the closeout package in order for reimbursement to be made.
- G. The GRANTEE agrees to acknowledge the role of the Federal Aid in Sport Fish Restoration Program funding in any publicity related to this Agreement.

5. COMPENSATION AND PAYMENT

A. COST REIMBURSEMENT

The GRANTEE shall be compensated for a maximum of \$60,000.00 on a cost reimbursement basis in accordance with the Cost Reimbursement Contract Payment Requirements as shown in the Department of Financial Services, "Reference Guide for State Expenditures" publication. The cost reimbursement requirements section of the Reference Guide is attached hereto and made a part hereof as Attachment D. The GRANTEE shall provide a minimum matching contribution as specified in Attachment B, Exhibit 1 and item 14(c) Federal Funds.

B. INVOICE SCHEDULE

A single final invoice may be submitted after completion of the deliverable and must be received by the COMMISSION no later than October 15, 2021 to assure availability of funds for payment. A timely reimbursement request following completion of actual field operations is strongly encouraged.

C. TRAVEL EXPENSES

No travel expenses are authorized under the terms of this Agreement.

D. FORMS AND DOCUMENTATION

- 1. The GRANTEE shall submit a completed Materials Placement Report form along with the invoice and request for payment. The Materials Placement Report form is available on the COMMISSION's website at: <http://www.myfwc.com/artificialreefs>.

6. MONITORING SCHEDULE

- A. The GRANTEE agrees to allow the COMMISSION to conduct on-site inspections of the artificial reef materials, staging area and construction site before, during, and after the deployment.

Attachment A – SCOPE OF WORK

Project Name:	Franklin County Artificial Reef Construction 2020-21	FWC Agreement No.	20011
----------------------	---------------------------------------------------------	--------------------------	-------

- B. The **COMMISSION** will monitor the **GRANTEE**'s service delivery to determine if the **GRANTEE** has achieved the required level of performance. If the **COMMISSION** in its sole discretion determines that the **GRANTEE** failed to meet any of the terms or conditions of the Agreement, the **GRANTEE** will be sent a formal written notice. The **GRANTEE** shall correct all identified deficiencies within forty-five (45) days of notice. Failure to achieve 100% compliance with all of the terms and conditions of this Agreement or failure to correct the deficiencies identified in a notice identifying deficiencies within the time frame specified may result in delays in payment, financial consequences, or termination of this Agreement in accordance with the terms of the Agreement.

- C. No additional monitoring activities have been identified at this time; however, additional tasks may be identified during the pendency of this agreement.

7. INTELLECTUAL PROPERTY RIGHTS

See Agreement for applicable terms and conditions related to the intellectual property rights.

8. SUBCONTRACTS

See Agreement for applicable terms and conditions related to subcontracts.

9. INSURANCE

See Agreement for applicable terms and conditions related to insurance.

10. SECURITY AND CONFIDENTIALITY

See Agreement for applicable terms and conditions related to security and confidentiality.

11. RECORD KEEPING REQUIREMENTS

See Agreement for applicable terms and conditions related to record keeping requirements.

12. NON-EXPENDABLE PROPERTY

The **GRANTEE** is not authorized to use funds provided herein for the purchase of any non-expendable equipment or personal property valued at \$1,000 or more for performance under this Agreement.

13. PURCHASE OR IMPROVEMENT OF REAL PROPERTY

This Section is not applicable and intentionally left blank.

14. SPECIAL PROVISIONS FOR CONSTRUCTION CONTRACTS

A. DRUG-FREE WORKPLACE

Pursuant to Section 440.102(15), F.S., any construction contractor regulated under Parts I and II of Chapter 489, F.S., who contracts to perform construction work under a state contract shall implement a drug-free workplace.

Attachment A – SCOPE OF WORK

Project Name:	Franklin County Artificial Reef Construction 2020-21	FWC Agreement No.	20011
----------------------	---------------------------------------------------------	--------------------------	-------

B. CONTRACTOR ELIGIBILITY

1. The use of a Marine Specialty licensed contractor (Section 489.105, F.S) is not a requirement for professional services pertaining to artificial reef deployment activities during this Agreement. A Marine Specialty Contractor license (Chapter 61G4-15.033 Florida Administrative Code) does not include artificial reefs, and therefore is not a licensing requirement for artificial reef deployment.
2. The Consultants Competitive Negotiation Act (Section 287.055, F.S.) is not applicable for professional services pertaining to artificial reef planning, procurement, deployment or survey activities during this Agreement. Signed and sealed drawings are not required.
3. In accordance with Executive Order 12549, Debarment and Suspension, the **GRANTEE** shall agree and certify that neither it, nor its principals, is presently debarred, suspended, proposed for debarment, declared ineligible, or voluntarily excluded from participation in this transaction by any Federal department or agency; and, that the **GRANTEE** shall not knowingly enter into any lower tier agreement, or other covered transaction, with a person who is similarly debarred or suspended from participating in this covered transaction, unless authorized in writing to the **COMMISSION** by the federal agency issuing the grant award. Upon execution of subcontracts funded by this Agreement, the **GRANTEE** shall require subcontractors to complete, sign and return a copy of the form entitled "Certification Regarding Debarments, Suspension, Ineligibility and Voluntary Exclusion - Lower Tier Federally Funded Transactions", attached hereto and made a part hereof as Attachment E. As required by sentences 1 and 2 above, the **GRANTEE** shall include the language of this section, and Attachment E in all subcontracts or lower tier agreements executed to support the **GRANTEE's** work under this Agreement.

C. FEDERAL FUNDS

1. This Agreement is funded in whole or in part by a grant from the U.S. Fish and Wildlife Service, Federal Aid in Sport Fish Restoration Program, CFDA No. 15.605. Therefore, the **GRANTEE** shall be responsible for complying with all federal grant requirements as provided in the grant, a copy of which is attached hereto and made a part hereof as Attachment C. It is understood and agreed that the **GRANTEE** is not authorized to expend any federal funds under this Agreement to a federal agency or employee without the prior written approval of the U.S. Fish and Wildlife Service.
2. The Davis-Bacon Act is not applicable to subcontracts executed under this Agreement. This project is funded by the Dingell-Johnson Sport Fish Restoration Act which does not require implementation of the provision of the Davis-Bacon Act as the initial federal award to the **COMMISSION** was exempt from the Davis-Bacon Act conditions.
3. The **GRANTEE** agrees to follow all requirements of CFR 200, Code of Federal Regulations, for the procurement of commodities or contractual services under this Agreement.

Attachment A – SCOPE OF WORK

Project Name:	Franklin County Artificial Reef Construction 2020-21	FWC Agreement No.	20011
----------------------	---------------------------------------------------------	--------------------------	-------

4. The **GRANTEE** shall be required to provide a minimum matching contribution of \$10,000.00 of the total project costs in support of the **COMMISSION's** grant from the U.S. Fish and Wildlife Service.
5. The **COMMISSION** shall make payment to the **GRANTEE** for an amount of the total project eligible cost less the \$10,000.00 match, not to exceed \$60,000.00 of approved invoiced costs. The \$10,000.00 of invoice costs not reimbursed by the **COMMISSION** shall represent the **GRANTEE's** matching contribution as required by the **COMMISSION's** grant from the U.S. Fish and Wildlife Service.

D. PAYMENT BOND

Pursuant to Chapter 287, F.S., no payment or surety bond is required for this project.

E. PERFORMANCE BOND

Pursuant to Chapter 287, F.S., no performance bond is required for this project.

F. CERTIFICATE OF CONTRACT COMPLETION

The Grantee will be required to complete a Certificate of Completion form (Attachment F) when all work has been completed and accepted. This form must be submitted to the **COMMISSION's** Contract Manager with the **GRANTEE's** invoice for payment to be authorized. The **COMMISSION's** Contract Manager shall submit the executed form with the invoice to Accounting Services.

G. CERTIFICATE OF PARTIAL PAYMENT

This Section is not applicable and intentionally left blank.

H. GRANTEE PAYMENTS TO SUBCONTRACTOR

Grant Agreement No. 20019, Section 15, B, "Grantee Payments to Subcontractor" is hereby amended to read as follows:

If subcontracting is permitted pursuant to Section 15, Paragraph A, the **GRANTEE** agrees to make payments to the subcontractor upon completion of work and submitted invoice in accordance with the contract between the **GRANTEE** and subcontractor. Failure to make payment pursuant to any subcontract within thirty (30) working days will result in a penalty charged against **GRANTEE** and paid to the subcontractor in the amount of one-half of one percent (0.50%) of the amount due per day from the expiration of the thirty (30) working day period allowed herein for payment. Such penalty shall be in addition to actual payments owed and shall not exceed fifteen percent (15%) of the outstanding balance due.

The remainder of this page intentionally left blank.



Department of Financial Services
Division of Accounting and Auditing – Bureau of Auditing

ATTACHMENT B
AUDIT REQUIREMENTS FOR AWARDS OF
STATE AND FEDERAL FINANCIAL ASSISTANCE

Note: Rule Chapter 69I-5, Florida Administrative Code (F.A.C.), State Financial Assistance, incorporates this form as well as the regulations cited therein by reference in Rule 69I-5.006, F.A.C.; Rule 69I-5.001, F.A.C., incorporates 2 CFR Part 200, Uniform Administrative Requirements, Cost Principles, and Audit Requirements for Federal Awards, including Subpart F - Audit Requirements, 2018 Edition, and its related Appendix XI, Compliance Supplement, April 2017 and April 2018. The form and regulations can be accessed via the Department of Financial Services' website at <https://apps.fldfs.com/fsaal>.

The administration of resources awarded by the Florida Fish and Wildlife Conservation Commission to the grantee may be subject to audits and/or monitoring by the Florida Fish and Wildlife Conservation Commission, as described in this section.

MONITORING

In addition to reviews of audits conducted in accordance with 2 CFR 200, Subpart F - Audit Requirements, and section 215.97, Florida Statutes (F.S.), as revised (see AUDITS below), monitoring procedures may include, but not be limited to, on-site visits by the Florida Fish and Wildlife Conservation Commission staff, limited scope audits as defined by 2 CFR §200.425, or other procedures. By entering into this agreement, the grantee agrees to comply and cooperate with any monitoring procedures or processes deemed appropriate by the Florida Fish and Wildlife Conservation Commission. In the event the Florida Fish and Wildlife Conservation Commission determines that a limited scope audit of the grantee is appropriate, the grantee agrees to comply with any additional instructions provided by the Florida Fish and Wildlife Conservation Commission staff to the grantee regarding such audit. The grantee further agrees to comply and cooperate with any inspections, reviews, investigations, or audits deemed necessary by the Chief Financial Officer (CFO) or Auditor General.

AUDITS

Part I: Federally Funded

This part is applicable if the grantee is a state or local government or a nonprofit organization as defined in 2 CFR §200.90, §200.64, and §200.70.

1. A grantee that expends \$750,000 or more in federal awards in its fiscal year must have a single or program-specific audit conducted in accordance with the provisions of 2 CFR 200, Subpart F - Audit Requirements. EXHIBIT 1 to this form lists the federal resources awarded through the Florida Fish and Wildlife Conservation Commission by this agreement. In determining the federal awards expended in its fiscal year, the grantee shall consider all sources of federal awards, including federal resources received from the Florida Fish and Wildlife Conservation Commission. The determination of amounts of federal awards expended should be in accordance with the guidelines established in 2 CFR §§200.502-503. An audit of the grantee conducted by the Auditor General in accordance with the provisions of 2 CFR §200.514 will meet the requirements of this Part.
2. For the audit requirements addressed in Part I, paragraph 1, the grantee shall fulfill the requirements relative to auditee responsibilities as provided in 2 CFR §§200.508-512.
3. A grantee that expends less than \$750,000 in federal awards in its fiscal year is not required to have an audit conducted in accordance with the provisions of 2 CFR 200, Subpart F - Audit Requirements. If the grantee expends less than \$750,000 in federal awards in its fiscal year and elects to have an audit conducted in accordance with the provisions of 2 CFR 200, Subpart F - Audit Requirements,

**AUDIT REQUIREMENTS FOR AWARDS OF
STATE AND FEDERAL FINANCIAL ASSISTANCE**

the cost of the audit must be paid from non-federal resources (i.e., the cost of such an audit must be paid from grantee resources obtained from other than federal entities).

Part II: State Funded

Note: This part is applicable if the grantee is a nonstate entity as defined by section 215.97(2), F.S.

1. In the event that the grantee expends a total amount of state financial assistance equal to or in excess of \$750,000 in any fiscal year of such grantee (for fiscal years ending June 30, 2017, and thereafter), the grantee must have a state single or project-specific audit for such fiscal year in accordance with section 215.97, F.S.; Rule Chapter 69I-5, F.A.C., State Financial Assistance; and Chapters 10.550 (local governmental entities) and 10.650 (nonprofit and for-profit organizations), Rules of the Auditor General. EXHIBIT 1 to this form lists the state financial assistance awarded through the Florida Fish and Wildlife Conservation Commission by this agreement. In determining the state financial assistance expended in its fiscal year, the grantee shall consider all sources of state financial assistance, including state financial assistance received from the Florida Fish and Wildlife Conservation Commission, other state agencies, and other nonstate entities. State financial assistance does not include federal direct or pass-through awards and resources received by a nonstate entity for federal program matching requirements.
2. For the audit requirements addressed in Part II, paragraph 1, the grantee shall ensure that the audit complies with the requirements of section 215.97(8), F.S. This includes submission of a financial reporting package as defined by section 215.97(2), F.S., and Chapters 10.550 (local governmental entities) and 10.650 (nonprofit and for-profit organizations), Rules of the Auditor General.
3. If the grantee expends less than \$750,000 in state financial assistance in its fiscal year (for fiscal years ending June 30, 2017, and thereafter), an audit conducted in accordance with the provisions of section 215.97, F.S., is not required. If the grantee expends less than \$750,000 in state financial assistance in its fiscal year and elects to have an audit conducted in accordance with the provisions of section 215.97, F.S., the cost of the audit must be paid from the nonstate entity's resources (i.e., the cost of such an audit must be paid from the grantee's resources obtained from other than state entities).

Part III: Other Audit Requirements

Note: This Part should be used to specify any additional audit requirements imposed by the state awarding entity that are solely a matter of that state awarding entity's policy (i.e., the audit is not required by federal or state laws and is not in conflict with other federal or state audit requirements). Pursuant to section 215.97(8), F.S., state agencies may conduct or arrange for audits of state financial assistance that are in addition to audits conducted in accordance with section 215.97, F.S. In such an event, the state awarding agency must arrange for funding the full cost of such additional audits.

Part IV: Report Submission

1. Copies of reporting packages for audits conducted in accordance with 2 CFR 200, Subpart F - Audit Requirements, and required by Part I of this form shall be submitted, when required by 2 CFR §200.512, by or on behalf of the grantee directly to the Federal Audit Clearinghouse (FAC) as provided in 2 CFR §200.36 and §200.512.

The FAC's website provides a data entry system and required forms for submitting the single audit reporting package. Updates to the location of the FAC and data entry system may be found at the OMB website.

2. Copies of financial reporting packages required by Part II of this form shall be submitted by or on behalf of the grantee directly to each of the following:

**AUDIT REQUIREMENTS FOR AWARDS OF
STATE AND FEDERAL FINANCIAL ASSISTANCE**

- a. The Commission at each of the following addresses:

Office of Inspector General
Florida Fish and Wildlife Conservation Commission
Bryant Building
620 S. Meridian St.
Tallahassee, FL 32399-1600

- b. The Auditor General's Office at the following address:

Auditor General
Local Government Audits/342
Claude Pepper Building, Room 401
111 West Madison Street
Tallahassee, Florida 32399-1450

The Auditor General's website (<https://flauditor.gov/>) provides instructions for filing an electronic copy of a financial reporting package.

3. Copies of reports or the management letter required by Part III of this form shall be submitted by or on behalf of the grantee directly to:

The Commission at each of the following addresses:

Office of Inspector General
Florida Fish and Wildlife Conservation Commission
Bryant Building
620 S. Meridian St.
Tallahassee, FL 32399-1600

4. Any reports, management letters, or other information required to be submitted to the Florida Fish and Wildlife Conservation Commission pursuant to this agreement shall be submitted timely in accordance with 2 CFR §200.512, section 215.97, F.S., and Chapters 10.550 (local governmental entities) and 10.650 (nonprofit and for-profit organizations), Rules of the Auditor General, as applicable.
5. Grantees, when submitting financial reporting packages to the Florida Fish and Wildlife Conservation Commission for audits done in accordance with 2 CFR 200, Subpart F - Audit Requirements, or Chapters 10.550 (local governmental entities) and 10.650 (nonprofit and for-profit organizations), Rules of the Auditor General, should indicate the date that the reporting package was delivered to the grantee in correspondence accompanying the reporting package.

Part V: Record Retention

The grantee shall retain sufficient records demonstrating its compliance with the terms of the award(s) and this agreement for a period of at least five years from the date the audit report is issued, and shall allow the Florida Fish and Wildlife Conservation Commission, or its designee, the CFO, or Auditor General access to such records upon request. The grantee shall ensure that audit working papers are made available to the Florida Fish and Wildlife Conservation Commission, or its designee, the CFO, or Auditor General upon request for a period of at least three years from the date the audit report is issued, unless extended in writing by the Florida Fish and Wildlife Conservation Commission.

**AUDIT REQUIREMENTS FOR AWARDS OF
STATE AND FEDERAL FINANCIAL ASSISTANCE**

Note: Records need to be retained for at least five years to comply with record retention requirements related to original vouchers as prescribed by the Department of State, Division of Library and Information Services, Bureau of Archives and Records Management.

**AUDIT REQUIREMENTS FOR AWARDS OF
STATE AND FEDERAL FINANCIAL ASSISTANCE**

EXHIBIT I

**Federal Resources Awarded to the Grantee
Pursuant to this Agreement Consist of the Following:**

Note: If the resources awarded to the grantee represent more than one federal program, provide the same information shown below for each federal program and show total federal resources awarded.

1. Federal Program A:
Federal Aid in Sport Fish Restoration Program, 15.605, \$37,168.47
2. Federal Program B:
not applicable

**Compliance Requirements Applicable to the Federal Resources
Awarded Pursuant to this Agreement are as Follows:**

Note: If the resources awarded to the grantee represent more than one federal program, list applicable compliance requirements for each federal program in the same manner as shown below.

1. Federal Program A:
 - A. Only the goods and/or services described within the attached Agreement and Attachment A Scope of Work are eligible expenditures for the funds awarded.
 - B. All provisions of Section 379.249, Florida Statutes and Rule 68E-9, Florida Administrative Code must be complied with in order to receive funding under this Agreement.
 - C. The Grantee must comply with the requirements of all applicable laws, rules or regulations relating to this artificial reef project.
 - D. The Grantee shall be required to provide a matching contribution of the total project costs (a minimum of \$10,000) in support of the Commission's grant from the U.S. Fish and Wildlife Service.
2. Federal Program B:
not applicable

Note: Instead of listing the specific compliance requirements as shown above, the state awarding agency may elect to use language that requires the grantee to comply with the requirements of applicable provisions of specific laws, rules, regulations, etc. For example, for Federal Program A, the language may state that the grantee must comply with specific laws, rules, regulations, etc., that pertains to how the awarded resources must be used or how eligibility determinations are to be made. The state awarding agency, if practical, may want to attach a copy of the specific laws, rules, regulations, etc., referred to.

**AUDIT REQUIREMENTS FOR AWARDS OF
STATE AND FEDERAL FINANCIAL ASSISTANCE**

State Resources Awarded to the Grantee

Pursuant to this Agreement Consist of the Following:

Matching Resources for Federal Programs:

Note: If the resources awarded to the grantee for matching represent more than one federal program, provide the same information shown below for each federal program and show total state resources awarded for matching.

1. Federal Program A:
Federal Aid in Sport Fish Restoration Program, 15.605, \$22,832.00
2. Federal Program B:
not applicable

Subject to Section 215.97, F.S.:

Note: If the resources awarded to the grantee represent more than one state project, provide the same information shown below for each state project and show total state financial assistance awarded that is subject to section 215.97, F.S.

1. State Project A:
not applicable
2. State Project B:
not applicable

Compliance Requirements Applicable to State Resources Awarded

Pursuant to this Agreement Are as Follows:

Note: List applicable compliance requirements in the same manner as illustrated above for federal resources. For matching resources provided by the Department of ABC for federal programs, the requirements might be similar to the requirements for the applicable federal programs. Also, to the extent that different requirements pertain to different amounts of the non-federal resources, there may be more than one grouping (i.e., 1, 2, 3, etc.) listed under this category.

1. State Project A:
not applicable
2. State Project B:
not applicable

Note: 2 CFR §200.513 and section 215.97(5); F.S., require that the information about federal programs and state projects included in EXHIBIT 1 be provided to the grantee.

For questions regarding Form DFS-A2-CL, contact your FSAA state agency liaison or the Department of Financial Services, Bureau of Auditing, at FSAA@MyFloridaCFO.com or (850) 413-3060.

Attachment C**State Grant Programs Part 523 Federal Aid Compliance Requirements****Chapter 1 Summary 523 FW 1.1**

1.1 Purpose. The purpose of this chapter is to summarize guidance on those requirements generally applicable to grant programs.

1.2 Applicability and Scope. In accepting Federal funds, States and other grantees must comply with all applicable Federal laws, regulations, and policies. This chapter is not all-inclusive. Exclusion of any specific requirement does not relieve grantees of their responsibility for compliance. Copies of reference materials can be obtained from the Regional Offices. Guidance on the following requirements is contained in this chapter.

A. Nondiscrimination Requirements.

- Title VI of the Civil Rights Act of 1964
- Section 504 of the Rehabilitation Act of 1973
- Age Discrimination Act of 1975
- Title IX of the Education Amendments of 1972

B. Environmental Requirements.

- Coastal Zone Management Act of 1972
- Executive Order 11987, Exotic Organisms
- Endangered Species Act of 1973
- National Environmental Policy Act of 1969
- Floodplains and Wetlands Protection
- Animal Welfare Act of 1985
- Coastal Barriers Resources Act of 1982

C. Historic and Cultural Preservation Requirements.

- National Historic Preservation Act of 1966

D. Administrative Requirements.

- Uniform Relocation Assistance and Real Property Acquisition Policies Act of 1970
- Debarment and Suspension
- Drug-Free Workplace Act of 1988
- Restrictions on Lobbying (P.L. 101-121)

1.3 Title VI of the Civil Rights Act of 1964 (42 U.S.C. 2000(d)).

A. Summary. Prohibits discrimination based on race, color, or national origin in any "program or activity receiving Federal financial assistance."

B. References.

- (1) Regulations of the Department of the Interior (43 CFR Part 17)
- (2) U.S. Fish and Wildlife Service Guidelines for Compliance with Federal Nondiscrimination Requirements
- (3) U.S. Fish and Wildlife Service Federally Assisted Program Implementation Plan

C. Requirements.

(1) Grantees may not, on the basis of race, color, or national origin, select, locate, or operate project facilities which will serve to exclude or limit opportunity for use or benefits.



Attachment C

(2) Grantees shall make reasonable efforts to inform the public of opportunities provided by Federal Aid projects and shall inform the public that the projects are subject to Title VI compliance.

(3) Though employment practices are not in themselves subject to Title VI, Title VI does apply to employment which may affect the delivery of services to beneficiaries of a federally assisted program. For the purpose of Title VI, volunteers or other unpaid persons who provide services to the public are included.

1.4 Section 504 of the Rehabilitation Act of 1973 (29 U.S.C. 795)

A. Summary. Ensures that no qualified handicapped person shall, on the basis of handicap, be excluded from participation in, be denied the benefits of, or be subjected to discrimination under any program or activity receiving Federal financial assistance.

B. References.

- (1) Regulations of the Department of the Interior (43 CFR Part 17)
- (2) U.S. Fish and Wildlife Service Guidelines for Compliance with Federal Nondiscrimination Requirements
- (3) U.S. Fish and Wildlife Service Federally Assisted Program Implementation Plan

C. Requirements.

- (1) Grantees may not deny a qualified handicapped person the opportunity to participate in or benefit from Federal Aid project facilities or services afforded to others.
- (2) Grantees may not deny a qualified handicapped person the opportunity to participate as a member of a planning or advisory board.
- (3) The location of facilities shall not have the effect of excluding handicapped persons from, deny them the benefits of, or otherwise subject them to discrimination under any Federal Aid project.

1.5 Age Discrimination Act of 1975 (42 U.S.C. 6101)

A. Summary. Prohibits discrimination on the basis of age in programs or activities receiving Federal financial assistance.

B. References.

- (1) Regulations of the Department of the Interior (43 CFR Part 17)
- (2) U.S. Fish and Wildlife Service Guidelines for Compliance with Federal Nondiscrimination Requirements
- (3) U.S. Fish and Wildlife Service Federally Assisted Program Implementation Plan

C. Requirements. No person in the United States shall, on the basis of age, be excluded from participation in, be denied the benefits of, or be subjected to discrimination under any program or activity receiving Federal financial assistance. However, a grantee is permitted to take an action otherwise prohibited if the action reasonably takes into account age as a factor necessary to the normal operation or achievement of any statutory objective of a program or activity.

1.6 Title IX of the Education Amendments of 1972 (20 U.S.C. 1681, et seq.)

A. Summary. Prohibits discrimination on the basis of sex in any education program receiving Federal financial assistance.



Attachment C**B. References.**

- (1) Regulations of the Department of the Interior (43 CFR Part 17)
- (2) U.S. Fish and Wildlife Service Guidelines for Compliance with Federal Nondiscrimination Requirements

C. Requirements. No person in the United States shall, on the basis of sex, be excluded from participation in, be denied the benefits of, or be subjected to discrimination under any education program receiving Federal financial assistance. For the purpose of Title IX, hunter education and aquatic education project activities are considered education programs.

1.7 Coastal Zone Management Act of 1972 (16 U.S.C. 1451 et. seq.)

A. Summary. The Act is intended to, "preserve, protect, develop, and where possible, to restore or enhance, the resources of the Nation's coastal zone..."

B. References. Regulations of the Department of Commerce (15 CFR 930).

C. Requirements. Federal Aid projects, which would "significantly affect the coastal zone" must be consistent with the approved State management programs developed under the Act. Prior to submitting a Grant Proposal for a project in the coastal zone of a State with an approved Coastal Zone Management Program, the proposed project must be reviewed for consistency with the management plan. Grantees may be required to submit a statement attesting to conformance with the Coastal Zone Management Plan.

1.8 Exotic Organisms Executive Order 11987

A. Summary. Federal agencies shall discourage the States from introducing exotic species into natural ecosystems of the United States. In addition, Federal agencies will restrict the use of Federal funds for the purpose of introducing exotic species into ecosystems outside of the United States.

B. References. Executive Order 11987, Exotic Organisms, 42 FR 26949 (May 25, 1977)

C. Requirements.

- (1) Any proposal for the introduction of an exotic species into a natural ecosystem by a State fish and wildlife agency must include a biological opinion from the U.S. Fish and Wildlife Service supporting the proposed introduction.
- (2) To obtain a biological opinion, the State agency shall provide the Regional Director with a written request for the opinion together with any available information including, but not limited to, NEPA documents, biological data, and project plans.
- (3) After receiving a biological opinion, it will be the responsibility of the State agency to adhere to the recommendations outlined in that opinion.

1.9 Endangered Species Act of 1973 (16 U.S.C. 1531-1534).

A. Summary. Actions funded under the Federal Aid programs must not jeopardize the continued existence of any endangered or threatened species, or result in the destruction or adverse modification of the habitat of the species.

B. Reference. Section 7 Consultation Requirements, 43 FR 870 (Jan. 4, 1978).

C. Requirements. The Regional Director must ensure that Federal Aid projects are not likely to jeopardize the continued existence of endangered or threatened species or result in the



Attachment C

destruction or adverse modification of critical habitat. For projects which may affect an endangered or threatened species, either beneficially or adversely, a formal Section 7 consultation is necessary. The State is required to name the listed species and/or critical habitat included; list the name, description, and location of the area; list objectives of the actions; and provide an explanation of the impacts of the actions on a listed species or its critical habitat.

1.10 National Environmental Policy Act of 1969 (42 U.S.C. 4321-4347).

A. Summary. Requires that every proposed Federal action be examined to determine the effects (beneficial or adverse) it will have on the human environment and that the findings be considered in decisions regarding its implementation.

B. References.

- (1) Regulations of the Council on Environmental Quality implementing the procedural provisions of NEPA, (40 CFR 1500-1508).
- (2) Departmental Manual, Environmental Quality, Part 516.
- (3) Fish and Wildlife Service Manual, National Environmental Policy Act, Part 550.
- (4) National Environmental Policy Act Handbook for Federal Aid Projects. The Assistant Director-Fish and Wildlife Enhancement is authorized to promulgate the National Environmental Policy Act Handbook for Federal Aid Projects.

C. Requirements. Each action proposed for Federal funding must include an Environmental Assessment (EA), Environmental Impact Statement (EIS), or show that the proposed activity is covered by one or more categorical exclusions. For specific requirements and procedures, see National Environmental Policy Act (NEPA) Handbook for Federal Aid Projects.

1.11 Floodplains and Wetlands Protection.

A. Summary. Federal Aid funds may not be used for projects affecting floodplains or wetlands unless there is no practical alternative outside the floodplain or wetland and only if actions are taken to minimize the adverse effects.

B. References.

- (1) Executive Order 11988, Floodplain Management, 42 FR 26951 (May 25, 1977).
- (2) Executive Order 11990, Protection of Wetlands, 42 FR 26961 (May 25, 1977).
- (3) Department of Interior Procedures for Implementation, 520 DM 1.
- (4) Natural Resources Protection, 613 FW.

C. Requirements. The Executive orders on floodplains and wetlands require Federal agencies to review proposed actions to ensure that there are no practical alternatives outside the floodplain or wetland, and to ensure that potential harm is minimized. If there are no practical alternatives to proposed projects in floodplains or wetlands, actions to minimize the adverse effects should be incorporated into the project plans.

1.12 Animal Welfare Act of 1985 7 U.S.C. 2131, et seq.

A. Summary. Requires the humane treatment of animals (exclusive of fish) used in research, experimentation, testing, and teaching.

B. References. Regulations of the Department of Agriculture, Animal and Plant Health Inspection Service (APHIS), 9 CFR Parts 1, 2 and 3 (54 FR 36112 (Aug. 31, 1989).



Attachment C

C. Requirements. Grantees who use Federal Aid funds to conduct covered management or research or who engage in interstate shipment of animals should contact the local Animal and Plant Health Inspection Service (APHIS) office for instructions. A list of the APHIS offices may be obtained from the Regional Offices.

1.13 Coastal Barriers Resources Act of 1982 (16 U.S.C. 3501), as amended by the Coastal Barrier Improvement Act of 1990 (P.L. 101-591)

A. Summary. The purpose of the Acts are "...to minimize the loss of human life, wasteful expenditure of Federal revenues and damage to fish and wildlife, and other natural resources associated with coastal barriers..."

B. References. U.S. Fish and Wildlife Service Advisory Guidelines, 48 FR 45664 (Oct. 6, 1983).

C. Requirements. Activities conducted within a unit of the Coastal Barrier Resources System must meet the requirements of section 6 of the Act. Section 6 requires consultation with the Service, via the appropriate Regional Office.

1.14 National Historic Preservation Act of 1966 16 U.S.C. 470.

A. Summary. Federal agencies may not approve any grant unless the project is in accordance with national policies relating to the preservation of historical and cultural properties and resources.

B. References.

- (1) National Register of Historic Places (36 CFR 60).
- (2) The Archeological and Historic Preservation Act of 1974, 16 U.S.C. 469a.
- (3) Procedures for the Protection of Historic and Cultural Properties (36 CFR 800).
- (4) Determinations of Eligibility for Inclusion in the National Register of Historic Places (36 CFR 63).
- (5) Criteria for Comprehensive Statewide Historic Surveys and Plans (36 CFR 61).
- (6) Cultural Resources Protection, 614 FW.

C. Requirements.

(1) States must consult with the State Historic Preservation Officer (SHPO) for those activities or projects that are defined as undertakings under the National Historic Preservation Act. An undertaking is defined as a project, activity, or program that can result in changes in the character or use of properties that are listed on or potentially eligible for listing on the National Register of Historic Places (National Register) and located within the project's area of potential effect. Undertakings include new and continuing projects, activities, or programs and any of their elements not previously considered under Section 106 of the National Historic Preservation Act.

(2) In cases where a Federal Aid project has been determined to be an undertaking, the State must notify the appropriate Service Regional Director for guidance on how to proceed with Section 106 compliance. Based on the results of the consultation between the State and SHPO, the Service will determine the need and level of inventory to identify historic properties that may be affected by the undertaking and to gather sufficient information to evaluate whether these properties are listed or are eligible for listing in the National Register.

(3) Where completed inventories indicate that identified historic properties may be affected by the undertaking, the State shall be responsible for submitting the necessary documentation to the appropriate Regional Director for review. As necessary, the Service shall seek



determinations of eligibility for those properties that are to be affected by the proposed activity.

(4) If a State is advised by the SHPO that an undertaking will adversely affect a property that is eligible for or listed on the National Register, the State shall ask the appropriate Regional Director to determine measures for mitigating or avoiding impacts. This may require the development of a memorandum of agreement among the Service, State, and State Historic Preservation Officer to address specific measures that will be employed to avoid or minimize adverse effects to historic properties located within the area of potential effect. Adverse effects that may diminish the character and integrity of historic properties include

- (a) Physical destruction, damage, or alteration of all or part of the property;
- (b) Isolation of the property from or alteration of the character of the property's setting when that character contributes to the property's qualification for the National Register of Historic Places;
- (c) Introduction of visual, audible, or atmospheric elements that are out of character with the property or alter its setting;
- (d) Neglect of a property resulting in its deterioration or destruction; and
- (e) Transfer, lease, or sale of the historic property.

(5) If a previously unknown property that is eligible for listing on the National Register is discovered at any time during the implementation period of a Federal Aid project, the Regional Director must be notified and all actions which may adversely effect it must be suspended. The Service shall provide the State with instructions on how to proceed.

1.15 Uniform Relocation Assistance and Real Property Acquisition Policies Act of 1970, as amended (42 U.S.C. 4601)

A. Summary. Federal agencies may not approve any grant unless the grantee provides Assurances that it will comply with the Act. Prices to be paid for lands or interests in lands must be fair and reasonable (except when the price is fixed by law, or when the lands are to be acquired at public auction or by condemnation and the value determined by the court). Persons displaced from their homes, businesses, and farms must receive relocation services, compensation, and fair equitable treatment.

B. References.

- (1) Department of Interior Uniform Relocation Assistance and Real Property Acquisition Regulations (41 CFR 114-50).
- (2) Department of Transportation Uniform Relocation Assistance and Real Property Acquisition for Federal and Federally Assisted Programs (49 CFR Part 24).

C. Appraisal Requirements.

- (1) A real property owner or his designated representative must be contacted prior to making an appraisal and given an opportunity to accompany the appraiser during inspection of the property. The fact that it occurred must be documented in project files and in the appraisal report.
- (2) Real property must be appraised, the appraisal report reviewed, and the fair market value established prior to initiation of negotiations with the owner.
- (3) If the acquisition of only part of a property will leave the owner with an uneconomic remnant, the State or other grantee must offer to buy the whole property. The term "uneconomic remnant" applies only to Title III of the Act and the necessity of the acquiring agency to offer to purchase such a remainder or the entire property. It is not to be construed with the term "uneconomic unit" as it applies to the in-lieu payment of farm operations under Title II of the Act.



Attachment C**D. Negotiation Requirements.**

- (1) An owner or his designated representative must be provided, in person or by certified mail, a written statement of just compensation as determined in the appraisal process. Offers of compensation cannot be less than the approved appraisal of fair market value of such property. If only a portion of the owner's property is being taken and the owner is left with an uneconomic remnant, the agency must offer to buy the whole property.
- (2) Reimbursement to a real property owner for costs to convey a title must include
- (a) Recording fees, transfer taxes, and similar costs;
 - (b) Penalty cost for prepayment of pre-existing recorded mortgage; and
 - (c) Pro-rata portion of real property taxes allocable to a period subsequent to the date of vesting title.
- (3) All displaced persons (owners and tenants) must be provided information on their relocation benefits.

E. Relocation Assistance to Displaced People.

- (1) A relocation plan must be prepared for displaced persons so that problems associated with displacement of individuals, families, businesses, farms and nonprofit organizations are known at an early stage in a project's development (see 49 CFR 24.205). Planning may involve the following
- (a) Who and what will be displaced.
 - (b) The estimated number of dwellings, businesses, farms, and nonprofit organizations displaced, including rentals. This estimate should contain
 - (i) Currently available replacement housing, businesses, farm, and organization sites;
 - (ii) Approximate number of employees affected;
 - (iii) Types of buildings, number, and size of rooms;
 - (iv) The needs of those displaced (i.e. lifestyle); and
 - (v) Type of neighborhood, distance to community facilities, church, etc.
 - (c) List of comparable replacement dwellings, including rentals, available on the market within a 50-mile radius (specialized units may require expanding radius). When an adequate supply of comparable housing is not expected to be available, consideration of Housing of the Last Resort actions should be instituted.
 - (d) Estimate of cost of replacement housing by purchase and/or rental per displaced person, and consideration of special needs like the elderly or handicapped.
 - (e) Estimate of cost for moving.
- (2) **Advisory Services for Displaced People.** Advisory services must be provided for all persons occupying property to be acquired and for all persons who use such real property for a business or farm operation. Eligibility requirements and corresponding benefits must be explained to all displaced persons. Assistance must be provided to persons completing claim forms, obtaining moving services, and obtaining proper housing.
- (3) **Payment for Relocation of Displaced Persons.** Relocation expenses must be paid to a displaced person who purchases and occupies a replacement dwelling. Moving and related expenses will be provided to displaced persons residing on real property including those persons owning a business or a farm. All payments must comply with the requirements of the Uniform Relocation Assistance and Real Property Acquisition Policies Act of 1970.



Attachment C

1.16 Debarment and Suspension

A. Summary. Executive Order 12549, Debarment and Suspension, directs that persons debarred or suspended by one Federal agency from receiving grants may not receive grants from any Federal agency.

B. References.

- (1) Executive Order 12549, Debarment and Suspension, Feb. 18, 1986.
- (2) Department of Interior Rules, Governmentwide Debarment and Suspension (Nonprocurement), 43 CFR 12.100 - 12.510

C. Requirements.

- (1) States and other grantees must submit the certification for Primary Covered Transactions (DI-1953). States certify as to their "principals", not the State agency. State principals are commissioners, directors, project leaders, or other persons with primary management or supervisory responsibilities, or a person who has a critical influence on or substantial control over Federal Aid projects. States may provide the certification annually. Other grantees must provide the certification with each Application for Federal Assistance.
- (2) States and other grantees must obtain from their subgrantees and contractors a certification for Lower Tier Covered Transactions (DI-1954). A certification is not required for small purchase procurements, currently defined as less than \$25,000. These certifications are normally provided with an application or proposal from a subgrantee or contractor.
- (3) States and other grantees must not make any award, either by subgrant or contract, to any party which is debarred or suspended or is otherwise ineligible under provisions of Executive Order 12549. The U.S. General Services Administration maintains a list of parties debarred, suspended, ineligible or excluded from participation in Federal grants under the provision of the Executive order. A copy of this list is available, upon request, from the Regional Director.

1.17 Drug-Free Workplace Act of 1988.

A. Summary. The Drug-Free Workplace Act requires that all grantees certify that they will maintain a drug-free workplace.

B. References. Department of Interior Rules, Drug-Free Workplace Requirements, 43 CFR 12.600-635.

C. Requirements. Grantee organizations must

- (1) Establish (and publish) a policy that informs employees that the manufacture, distribution, possession, or use of a controlled substance in the workplace is prohibited;
- (2) Establish an awareness program to inform employees of the dangers of drug abuse in the workplace; and

Provide a drug-free workplace certification to the Department of Interior or U.S. Fish and Wildlife Service. The forms for providing the certification are available from the Regional Director. State agencies may certify annually. If the State agency is covered by a consolidated certification for all State agencies, a copy of the consolidated certification should be submitted to the Regional Director. (The original is retained by the State.) Grantees other than State agencies must submit the certification with each Grant Agreement.



Attachment C**1.18 Restrictions on Lobbying (P.L. 101-121)**

A. Summary. Prohibits the use of Federal appropriated funds for lobbying either the executive or legislative branches of the Federal Government in connection with a specific contract, grant, loan, or cooperative agreement.

B. References. Department of the Interior Rules, 43 CFR Part 18, New Restrictions on Lobbying.

C. Requirements.

(1) Recipients of Federal grants are prohibited from using Federal appropriated funds, e.g. grants, to pay any person for influencing or attempting to influence an officer or employee of any Federal agency, a member of Congress, or an employee of a member of Congress in connection with a specific contract, grant, loan, or cooperative agreement.

(2) Proposals for grants in excess of \$100,000 must contain a certification that no part of the funds requested will be used for lobbying. Copies of the certification form, Form DI-1963, can be obtained from the Regional Offices.

(3) Recipients of grants in excess of \$100,000 must file a disclosure form on lobbying activities conducted with other than Federal appropriated funds. Form SF-LLL and SF-LLL-A, Continuation Sheet, shall be used for this purpose. Copies of the forms can be obtained from the Regional Office.



Attachment D

COST REIMBURSEMENT CONTRACT PAYMENT REQUIREMENTS

Pursuant to the February, 2011 *Reference Guide for State Expenditures* published by the Department of Financial Services, invoices submitted for cost reimbursement must be itemized by expenditure category as outlined in the approved contract budget. Additionally, the invoice must evidence the completion of all tasks required to be performed for the deliverable and must show that the provider met the minimum performance standards established in the contract.

FWC is required to maintain the detailed supporting documentation in support of each request for cost reimbursement and to make it available for audit purposes. Documentation for each amount for which reimbursement is being claimed must indicate that the item has been paid. Check numbers may be provided in lieu of copies of actual checks. Each piece of documentation should clearly reflect the dates of service. Only expenditures for the categories in the approved contract budget may be reimbursed. These expenditures must be allowable (pursuant to law) and directly related to the services being provided. FWC may require more detailed documentation as deemed appropriate to satisfy that the terms of the contract have been met.

Listed below are types and examples of supporting documentation:

- (1) Salaries: A payroll register or similar documentation should be submitted. The payroll register should show gross salary charges, fringe benefits, other deductions and net pay. If an individual for whom reimbursement is being claimed is paid by the hour, a document reflecting the hours worked times the rate of pay will be acceptable.
- (2) Fringe Benefits: Fringe Benefits should be supported by invoices showing the amount paid on behalf of the employee (e.g., insurance premiums paid). If the contract specifically states that fringe benefits will be based on a specified percentage rather than the actual cost of fringe benefits, then the calculation for the fringe benefits amount must be shown.

Exception: Governmental entities are not required to provide check numbers or copies of checks for fringe benefits.
- (3) Travel: Reimbursement for travel must be in accordance with Section 112.061, Florida Statutes, which includes submission of the claim on the approved State travel voucher.
- (4) Other direct costs: Reimbursement will be made based on paid invoices/receipts.
- (5) In-house charges: Charges which may be of an internal nature (e.g., postage, copies, etc.) may be reimbursed on a usage log which shows the units times the rate being charged. The rates must be reasonable.
- (6) Indirect costs: If the contract specifies that indirect costs will be paid based on a specified rate, then the calculation should be shown.

For cost reimbursement contracts with another State agency (including State universities):

In lieu of the detailed documentation described above, alternative documentation may be submitted to substantiate the costs requested to be reimbursed. This alternative documentation may be in the form of FLAIR reports or other reports containing sufficient detail.

**Attachment E
CERTIFICATION REGARDING DEBARMENTS, SUSPENSION, INELIGIBILITY AND
VOLUNTARY EXCLUSION-LOWER TIER FEDERALLY FUNDED TRANSACTIONS**

Required for all contractors and subcontractors on procurement (vendor) contracts of \$100,000 or more, and for all contracts and grants with sub-recipients regardless of amount, when funded by a federal grant.

1. The undersigned hereby certifies that neither it nor its principals is presently debarred, suspended, proposed for debarment, declared ineligible, or voluntarily excluded from participation in this transaction by any Federal department or agency.
2. The undersigned also certifies that it and its principals:
 - (a) Have not within a three-year period preceding this response been convicted of or had a criminal offense in connection with obtaining, attempting to obtain, or performing a public (Federal, State or local) transaction or contract under a public transaction; violation of Federal or State anti-trust statutes or commission of embezzlement, theft, forgery, bribery, falsification or destruction of records, making false statements, or receiving stolen property.
 - (b) Are not presently indicted for or otherwise criminally or civilly charged by a governmental entity (Federal, State or local) with commission of any of the offenses enumerated in paragraph 2.(a) of this Certification; and
 - (c) Have not within a three-year period preceding this certification had one or more public transactions (Federal, State or local) terminated for cause or default.
3. Where the undersigned is unable to certify to any of the statements in this certification, an explanation shall be attached to this certification.

Dated this _____ day of _____, 20__.

By: _____
Authorized Signature/Contractor

Typed Name/Title

Grantee Name/Contractor Name

Street Address

Building, Suite Number

City/State/Zip Code

Area Code/Telephone Number

**INSTRUCTIONS FOR CERTIFICATION REGARDING DEBARMENT,
SUSPENSION, INELIGIBILITY AND VOLUNTARY EXCLUSION-
LOWER TIER FEDERALLY FUNDED TRANSACTIONS**

1. By signing and submitting this form, the certifying party is providing the certification set out below.
2. The certification in this clause is a material representation of fact upon which reliance was placed when this transaction was entered into. If it is later determined that the certifying party knowingly rendered an erroneous certification, in addition to other remedies available to the Federal Government, the Florida Fish and Wildlife Conservation Commission (FWC) or agencies with which this transaction originated may pursue available remedies, including suspension and/or debarment.
3. The certifying party shall provide immediate written notice to the person to which this contract is submitted if at any time the certifying party learns that its certification was erroneous when submitted or has become erroneous by reason of changed circumstances.
4. The terms covered transaction, debarred, suspended, ineligible, lower tier covered transaction, participant, person, primary covered transaction, principal, proposal, and voluntarily excluded, as used in this clause, have the meanings set out in the Definitions and Coverage sections of rules implementing Executive Order 12549. You may contact the person to which this contract is submitted for assistance in obtaining a copy of those regulations.
5. The certifying party agrees by submitting this contract that, should the proposed covered transaction be entered into, it shall not knowingly enter into any lower tier contract, or other covered transaction with a person who is debarred, suspended, declared ineligible, or voluntarily excluded from participation in this covered transaction, unless authorized by the FWC or agency with which this transaction originated.
6. The certifying party further agrees by executing this contract that it will include this clause titled "Certification Regarding Debarment, Suspension, Ineligibility and Voluntary Exclusion-Lower Tier Covered Transaction," without modification, in all contracts or lower tier covered transactions and in all solicitations for lower tier covered transactions.
7. A participant in a covered transaction may rely upon a certification of a prospective participant in a lower tier covered transaction that it is not debarred, suspended, ineligible, or voluntarily excluded from the covered transaction, unless it knows that the certification is erroneous. A participant may decide the method and frequency by which it determines the eligibility of its principals. Each participant may, but is not required to, check the Nonprocurement List (Telephone No. (202) 501-4740 or (202) 501-4873.)
8. Nothing contained in the foregoing shall be construed to require establishment of a system of records in order to render in good faith the certification required by this clause. The knowledge and information of a participant is not required to exceed that which is normally possessed by a prudent person in the ordinary course of business dealings.
9. Except for transactions authorized under paragraph 5 of these instructions, if a participant in a covered transaction knowingly enters into a lower tier covered transaction with a person who is suspended, debarred, ineligible, or voluntarily excluded from participation in this transaction, in addition to other remedies available to the Federal Government, the FWC or agency with which this transaction originated may pursue available remedies, including suspension and/or debarment.

debar.226/rev.12/00



**FL FISH AND WILDLIFE CONSERVATION COMMISSION
DIVISION OF MARINE FISHERIES MANAGEMENT
ARTIFICIAL REEF PROGRAM
CERTIFICATION OF COMPLETION**

I, _____
(Printed Name and Title)

representing _____
(Name of Grantee)

do hereby certify that the artificial reef project funded by Grant Number FWC - _____
has been completed in compliance with all terms and conditions of said
Grant Agreement.

(Signature)

(Date)

FRANKLIN COUNTY, FLORIDA
2021 ARTIFICIAL REEF PROJECT

REQUEST FOR PROPOSALS

**DEADLINE FOR COMPLETION OF DEPLOYMENT
UNDER THIS PROJECT IS 8-1-2021**

RFP # 2020-01

NOTICE TO PROPOSERS – RFP #2020-01

Notice is hereby given that Franklin County, Florida (the “County”) will accept sealed proposals until 4:00 PM (Eastern Time), on the 5th day of April, 2021, for the Franklin County, Florida Buddy Ward 2020-2021 Artificial Reef Project. The project consists of the construction and deployment of at least twenty five (25) concrete prefabricated reef modules, or other concrete structures acceptable to the FWC (the “Commission”), all of which must be at least four (4) feet tall with a base diameter of at least six (6) feet, a weight of at least two (2) tons and made with marine grade concrete with a minimum strength of 4,000 psi. Each module is to consist of concrete with no exposed metal framework and designed with multiple openings of various sizes all the way through the outer surface to allow for water circulation and access by fish. Open-bottom prefabricated modules may not be used unless each module has a top opening sufficiently large to allow for turtle escapement (additional details are set forth below). The modules shall be deployed so as to construct three (3) reef complexes in the Buddy Ward permit site (specific location is set forth below) offshore of Apalachicola, Florida. Copies of the provisions, forms, and specifications may be obtained from Erin Griffith, Franklin County Fiscal Manager/Grants Coordinator, at 850-653-9783 (Ext. 158) during normal working hours.

At the County Commission Meeting on the 6th day of April, 2021 at 34 Forbes Street, Apalachicola, FL the proposals will be opened and read. All proposals must be in a sealed envelope reflecting on the outside thereof the proposer’s name and **“Franklin County, Florida 2020-2021 Buddy Ward Artificial Reef Project to be opened on the 6th day of April, 2021.”**

There is no obligation on the part of the County to award the proposal to the lowest bidder, and the County reserves the right to award the proposal to the bidder submitting a responsive proposal with the highest ranking with a resulting negotiated agreement which is most advantageous and in the best interest of the County and to waive any irregularity or technicality in proposals received. The County shall be the sole judge of the proposal and the resulting negotiating agreement that is in its best interest and its decision shall be final. Any bidder failing to mark the outside of the envelope, as set forth herein, may not be entitled to have their proposal considered. The County is utilizing requests for proposals (“RFP”) because various combinations or versions of the deployed material which meet the specifications of this RFP may be proposed by a responsive vendor. If a negotiated agreement is not reached with the highest ranked bidder, then negotiation will commence with the next highest bidder, and so on, until a negotiated agreement is reached.

The Board of County Commissioners reserves the right to waive informalities in any bid, to accept and/or reject any and all bids. If the contract is to be awarded, it will be awarded to the lowest responsive bidder. All bids shall remain firm for a period of sixty days after the opening.

All bidders shall comply with all applicable Federal, State and local laws concerning licensing, registration and regulation of contractors doing business in the State of Florida.

Deadline for all services to be provided by successful bidder/contractor is August 1, 2021.

All proposals should be addressed to the Franklin County Board of County Commissioners and will be received until 4:00 p.m. (Eastern Time), on April 5th, 2021 at the Franklin County Clerk's Office, Franklin County Courthouse, 33 Market Street, Suite 203, Apalachicola, FL 32320-2317.

If you have any questions, please contact Erin Griffith at (850) 653-9783, Ext. 158.

SPECIFICATIONS

RFP #: 2020-01

RFP ITEM: FRANKLIN COUNTY, FLORIDA 2020-2021 BUDDY WARD ARTIFICIAL REEF PROJECT

The purpose of this request for proposals (RFP) is to secure sealed proposals for the construction, acquisition and deployment of clean concrete pre-fabricated structures as described in **Attachment "A."**

The County reserves the right to choose the contractor and material that best meets its needs and to select quantities of its choice.

This project is funded by the U. S. Fish & Wildlife Service (Federal Aid in Sport Fish Restoration Program) and the Florida Fish & Wildlife Conservation Commission (Division of Marine Fisheries Artificial Reef Grants Program).

Proposals must include a concise description of the type of material being submitted. Description should include size, weight, pictures (if possible) and literature (if appropriate) in accordance with the criteria described in Attachment "A". The County reserves the right to disqualify any RFP that does not appear, to the County, to provide clear descriptive information.

Selection will be based on criteria (point system) as described in **Attachment "A"**.

SPECIAL CONDITIONS

1. The County reserves the right to waive any informalities or reject any and all proposals, in whole or part, and to accept the proposal that in its judgment will best serve the interest of the County. The County specifically reserves the right to reject any conditional proposal and will normally reject those that made it impossible to determine the true amount of the proposal.
2. **Addition/Deletion of Items:** The County reserves the right to add or delete any item from this proposal or resulting contract when deemed to be in the County's best interest.
3. **PIGGYBACKING:** The County hereby authorizes other agencies to piggyback, the practice of one agency using the procurement/agreement of another agency, on this Contract with Contractor's consent. The terms and conditions of the new contract, including the scope of work and volume of goods or services, must be the same as those of this contract.
4. Proposals will not be considered from vendors who are currently involved in official financial re-organization or bankruptcy proceedings.
5. **Payments:** The contractor shall be paid upon submission of invoices, in duplicate, to the Franklin County, FL County Commission, c/o Erin Griffith, Fiscal Manager/Grants Coordinator, 33 Market Street, Suite 203, Apalachicola, FL 32320 or by Erin Griffith to erin@franklincountyflorida.com. The prices stipulated herein for articles delivered and accepted invoices must show purchase order numbers.
6. **Information:** Written typed questions concerning proposal requirements or specifications should be directed to Franklin County, FL County Commission, c/o Erin Griffith – Fiscal Manager/ Grants Coordinator, 33 Market Street, Suite 203, Apalachicola, FL 32320, seven (7) days prior to the bid deadline as identified above. Any changes by the County to specifications shall be in writing in the form of an addendum and furnished to all proposers. Verbal information obtained otherwise will not be considered in awarding of proposal. A non-mandatory pre-bid teleconference will be held on the 22nd day of March, 2021, at 1:30 p.m., Eastern Time. Any potential bidder may participate in this meeting by attending via Zoom teleconference – please contact Erin Griffith at 850-653-9783 Ext. 158 for the number and login information.
7. **Right to Waive & Reject:**
 - A. The County, in its absolute discretion, may reject any proposal of a proposer that has failed, in the opinion of the County, to complete or perform this County contracted project in a timely fashion or has failed in any other way, in the opinion of the County, to perform the contract in a satisfactory manner.
 - B. There is no obligation on the part of the County to award the proposal to the lowest proposer, and the County reserves the right to award the proposal to the proposer submitting a responsive proposal with a resulting negotiated agreement which is most advantageous and in the best interest of the County, and to reject any and all proposals or to waive any irregularity or technicality in proposals received. The

County shall be the sole judge of the proposal and the resulting negotiated agreement that is in its best interest and their decision shall be final.

- C. The County reserves the right to waive any informalities or reject any and all proposals, in whole or part, to utilize any applicable state contracts in lieu of or in addition to this proposal and to accept the proposal that in its judgment will best serve the interest of the County.
- D. The County specifically reserves the right to reject any conditional proposal and will normally reject those that made it impossible to determine the true amount of the proposal. Each item must be proposed separately and no attempt is to be made to tie any item or items to any other item or items.

8. Disqualification of Proposers:

Any of the following reasons may be considered as sufficient for the disqualification of a proposer and the rejection of his proposal or proposals:

- A. More than one proposal for the same work from an individual, firm or corporation under the same or different name.
- B. Evidence that the proposer has a financial interest in the firm of another proposer for the same work.
- C. Evidence of collusion among proposers. Participants in such collusion will receive no recognition as proposers for any future work of the County until such participant shall have been reinstated as a qualified proposer.
- D. Uncompleted work that in the judgment of the County might hinder or prevent the prompt completion of additional work if awarded.
- E. Failure to pay or satisfactorily settle all bills due for labor and material on former contracts in force at the time of advertisement of proposals.
- F. Default under previous contract.
- G. The County, in their absolute discretion, may reject any proposal of a proposer that has failed, in the opinion of the County, to complete or perform a County contracted project in a timely fashion or has failed in any other way, in the opinion of the County, to perform a prior contract in a satisfactory manner.

9. Proposal Opening: Opening shall be public on the date and time specified. It is the proposer's responsibility to assure that his proposal is delivered at the proper time and place. Offers by telegram, facsimile, or telephone are **NOT ACCEPTABLE**. **NOTE:** The County is "**not a next day guaranteed delivery location**" by delivery services.

10. **Public Entity Crime Information:** A person or affiliate who has been placed on the convicted vendor list following a conviction for a public entity crime may not submit a proposal on a contract to provide any goods or services to a public entity, may not submit a proposal on a contract with a public entity for the construction or repair of a public building or public work, may not submit proposals on leases of real property to a public entity, may not be awarded or perform work as a contractor, supplier, subcontractor, or consultant under a contract with any public entity, and may not transact business with any public entity in excess of the threshold amount provided in Section 287.017, for CATEGORY TWO for a period of 36 months from the date of being placed on the convicted vendor list.

11. **Conflict of Interest:** The award hereunder is subject to the provisions of Chapter 112, Florida Statutes. All respondents must disclose with their proposal the name of any officer, director, or agent who is also a public officer or an employee of the County.

Furthermore, all respondents must disclose the name of any County officer or employee who owns, directly or indirectly, any interest of five percent (5%) or more in the firm or any of its branches.

Furthermore, the official, prior to or at the time of submission of the proposal, must file a statement with the County, if he/she is an officer or employee of the County, disclosing his/her or spouse's or child's interest and the nature of the intended business.

NOTE: For proposer's convenience, this certification form is enclosed and is made a part of the proposal package.

12. **Certifications and Assurances:** Preference shall be given to businesses with drug-free workplace programs. Whenever two or more proposals which are equal with respect to price, quality and service are received by the County for the procurement of commodities or contractual services, a proposal received from a business that certifies that it has implemented a drug-free workplace program shall be given preference in the award process (see attached certification form).

NOTE: For proposer's convenience, this certification form is enclosed and is made a part of the proposal package.

13. **Discrimination:** An entity or affiliate who has been placed on the discriminatory vendor list may not submit a proposal on a contract to provide goods or services to a public entity, may not submit a proposal on a contract with a public entity for the construction or repair of a public building or public work, may not submit proposals on leases of real property to a public entity, may not award or perform work as a contractor, supplier, subcontractor, or consultant under contract with any public entity, and may not transact business with any public entity.

14. **Indemnification & Hold Harmless:** To the fullest extent permitted by law, CONTRACTOR shall indemnify and hold harmless County, its officers and employees from liabilities, damages, losses, and costs including but not limited to reasonable attorney fees, to the extent caused by the negligence, recklessness, or intentionally wrongful conduct of the

CONTRACTOR and other persons employed or utilized by the CONTRACTOR in the performance of this Agreement.

NOTE: For proposer's convenience, this certification form is enclosed and is made a part of the proposal package.

15. Contractor's Insurance:

- A. The **CONTRACTOR** shall not commence work in connection with this Agreement until he has obtained all required insurance and such insurance has been approved by the County.
- B. All insurance policies shall be with insurers licensed to do business in the State of Florida, and any insuring company is required to have a minimum rating of A, Class X in the Best Key Rating Guide published by A. M. Best & Co., Inc.
- C. The County shall retain the right to reject all insurance contracts that do not meet the requirement of this Agreement. Further, the County reserves the right to change these insurance requirements with 60-day notice to the **CONTRACTOR**.
- D. The insurance definition of Insured or Additional Insured shall include Subcontractor, Sub-subcontractor, and any associated or subsidiary companies of the **CONTRACTOR** which are involved, and which is a part of the contract.
- E. The County reserves the right at any time to require the **CONTRACTOR** to provide certified copies of any insurance policies to document the insurance coverage specified in this Agreement.
- F. The designation of **CONTRACTOR** shall include any associated or subsidiary company which is involved and is a part of the contract and such, if any associated or subsidiary company involved in the project, must be named in the Workers' Compensation coverage.
- G. All policies shall be written so that the County will be notified of cancellation or restrictive amendments at least thirty (30) days prior to the effective date of such cancellation or amendment. Such notice shall be given directly to the County Representative.
- H. All insurance contracts, except the Workers' Compensation shall list the County as an Additional Insured. **CONTRACTOR** shall provide the County current Certificates of Insurance for all policies at least ten days before commencing work.

16. Workers' Compensation Insurance:

- A. The **CONTRACTOR** shall secure and maintain during the life of this agreement Workers' Compensation insurance, Joes Act insurance, Maritime insurance or appropriate/applicable coverage that acts or serves as "worker's compensation insurance coverage" for all employees employed including supervision, administration and management personnel. In case any work is sublet with the approval of the County, the **CONTRACTOR** shall require the Subcontractor to provide Workers' Compensation insurance for all employees. **All contractors/subcontractors will submit a copy of their certificate of Worker's Compensation Insurance with their bids. Bids not containing this certification will be cause for rejection of bid.** Evidence of such insurance shall be furnished by County not less than ten (10) days prior to the commencement of any and all subcontracted work.
- B. Such insurance shall comply with the Florida Workers' Compensation Law.
- C. Coverage shall include a waiver or subrogation clause in favor of the County. Also, this endorsement must be indicated on all Certificates of Insurance.
- D. Contractor shall insure and/or otherwise comply with the Federal Longshoremen and Harbor Workers Act and the Jones Act, if applicable.

17. Business Automobile & Public Liability Insurance:

- A. The **CONTRACTOR** shall maintain Business Automobile Liability insurance coverage throughout the life of this Agreement. The insurance shall include Owned, Non-Owned and Hired motor vehicle coverage.
- B. The **CONTRACTOR** shall carry other Public Liability insurance against all other Bodily Injury, Property Damage and Personal and Advertising Injury exposures.
- C. In addition to the required coverage in B above, Public Liability coverage shall include the following:
 - 1) On and Off Premises Operation Liability
 - 2) Personal Injury Liability Insurance
 - 3) Independent Contractor Liability
 - 4) Completed Operations & Products Liability
- D. The **CONTRACTOR** shall agree to maintain in force Commercial General Liability Insurance including Completed Operations and Products Liability coverage for at least two years following acceptance of the project by the County.
- E. All liability insurance shall be written on an occurrence basis and shall not be written on a claim-made basis. If the insurance is issued with an aggregate limit of

liability, the aggregate limit of liability shall apply only to the locations included in this Agreement. If, as the result of any claims or other reasons, the available limits of insurance reduce to less than those stated in the LIMITS OF LIABILITY, the **CONTRACTOR** shall notify the County representative in writing. The **CONTRACTOR** shall purchase additional liability insurance to maintain the requirements established in this Agreement. Umbrella or Excess Liability insurance can be purchased to meet the Limits of Liability specified in this Agreement.

Limits of Liability:

The insurance required shall be written for not less than the following limits unless law requires higher amounts:

<u>COVERAGE</u>	<u>LIMIT</u>
1. Workers Compensation/Jones Act, etc... (See Paragraph 16 above)	
a. State	Statutory
b. Employers Liability	\$1 million each accident
2. Business Automobile & Commercial Grant Liability Insurance	\$1 million each occurrence (Combined Single Limit)
3. Personal & Advertising Injury	\$250,000

18. **Notice of Claims or Litigation:** The **CONTRACTOR** agrees to report any incident or claim that results from performance of this Agreement. Within ten (10) days of the **CONTRACTOR'S** knowledge, the County Representative shall receive written notice describing the incident or claim. In the event such incident or claim involves injury or property damage to a third party, verbal notification shall be given the same day the **CONTRACTOR** becomes aware of the incident or claim. A detailed written report is to be made within ten (10) days).

19. Certificate of Insurance:

A. All insurance shall include the interest of all entities names in and its respective agents, consultants, servants and employees of each and all other interests as may be reasonably required by the County as Additional Insured. The coverage afforded the Additional Insured under this policy shall be primary insurance. If the Additional Insured has other insurance that is applicable to the loss, such other insurance shall be on an excess or contingent basis. The amount of the company's liability under this policy shall not be reduced by the existence of such other insurance.

- B. Certificates of Insurance, in duplicate, indicating the job-site and evidencing all required coverage must be submitted to and approved by the County prior to the commencement of any of the work. The certificate holder(s) shall be as follows:

Franklin County Board of County Commissioners
33 Market Street, Suite 203
Apalachicola, FL 32320

- C. All policies shall expressly require 30 days written notice to the County at the address set out above, or the cancellations of material alterations of such policies, and the Certificates of Insurance, shall so provide. The certificate, if on a Standard Accord, shall not include language such as "if any" or but failure to mail such notice shall impose on obligation or liability of any kind upon the County, its agents or representatives.
- D. All certificates shall be subject to the County's approval of adequacy of protection and the satisfactory character of the Insurer.
- E. The Certificates of Insurance shall disclose any and all deductibles or self-insured detentions (SIRs). Deductibles or SIRs in excess of \$10,000 will not be accepted unless specifically approved in writing by the County. All deductibles or SIRs, whether approved by the County or not, shall be the Contractor's full responsibility. In particular, the Contractor shall afford full coverage as specified herein to entities listed as Additional Insured.

In no way will the entities listed as Additional Insured be responsible for, pay for, be damaged by, or limited to coverage required by this schedule due to the existence of a deductible or SIR. Specific written approval from the County will only be provided upon demonstration that the Contractor has the financial capability and funds necessary to cover the responsibilities incurred as a result of the deductible or SIR.

- F. In the event of failure of the Contractor to furnish and maintain said insurance and to furnish satisfactory evidence thereof, the County shall have the right (but not the obligation) to take out and maintain insurance on the project. All costs for the coverage will be paid by Contractor upon presentation of a bill.

20. General Terms:

Any type of insurance or increase of limits of liability not described above which the Contractor required for its own protection or on account of statute shall be its own responsibility and at its own expense.

The carrying of the insurance described shall in no way be interpreted as relieving the Contractor of any responsibility under this contract.

Should the Contractor engage a subcontractor or sub-subcontractor, the same conditions will apply under this agreement to each subcontractor and sub-subcontractor.

The Contractor hereby waives all rights of subrogation against the County and its consultants and other indemnities of the Contractor under all the foregoing policies of insurance.

21. Umbrella Insurance:

The Contractor shall have the right to meet the liability insurance requirements with the purchase of an umbrella insurance policy. In all instances, the combination of primary and umbrella liability coverage must equal or exceed the minimum liability insurance limits stated in this agreement.

21. EMPLOYMENT ELIGIBILITY VERIFICATION (E-VERIFY)

A. Requirement to Use E-Verify. Executive Order 11-116, signed May 27, 2011, by the Governor of Florida, requires Commission contracts in excess of nominal value to expressly require the Grantee to: 1.) utilize the U.S. Department of Homeland Security's E-Verify system to verify the employment eligibility of all new employees hired by Grantee during the Agreement term; and, 2.) include in all subcontracts under this Agreement, the requirement that subcontractors performing work or providing services pursuant to this Agreement utilize the E-Verify system to verify the employment eligibility of all new employees hired by the subcontractor during the term of the subcontract.

B. E-Verify Online. E-Verify is an Internet-based system that allows an employer, using information reported on an employee's Form I-9, Employment Eligibility Verification, to determine the eligibility of all new employees hired to work in the United States after the effective date of the required Memorandum of Understanding (MOU); the responsibilities and elections of federal contractors, however, may vary, as stated in Article II.D.1.c. of the MOU. There is no charge to employers to use E-Verify. The Department of Homeland Security's E-Verify system can be found online at http://www.dhs.gov/files/programs/gc_1185221678150.shtm

C. Enrollment in E-Verify. If Contractor does not have an E-Verify MOU in effect, the Contractor must enroll in the E-Verify system prior to hiring any new employee after the effective date of this Agreement.

D. E-Verify Recordkeeping. The Contractor further agrees to maintain records of its participation and compliance with the provisions of the E-Verify program, including participation by its subcontractors as provided above, and to make such records available to the Commission or other authorized state entity consistent with the terms of the Contractor's enrollment in the program. This includes maintaining a copy of proof of the Contractor's and subcontractors' enrollment in the E-Verify Program (which can be accessed from the "Edit Company Profile" link on the left navigation menu of the E-Verify employer's homepage).

E. Employment Eligibility Verification. Compliance with the terms of the Employment Eligibility Verification provision is made an express condition of this Agreement and the Commission may treat a failure to comply as a material breach of the Agreement.

ATTACHMENT A
SCOPE OF WORK

Franklin County, Florida
2020-2021 Buddy Ward Artificial Reef Project

Franklin County, Florida will be administering an artificial reef construction project in the Buddy Ward Permit site off the coast of Apalachicola, Florida.

The project consists of the construction and deployment of:

At least twenty five (25) concrete prefabricated reef modules (the “Modules”), or other concrete structures acceptable to the FWC (the “Commission”), all of which must be at least four (4) feet tall with a base diameter of at least six (6) feet, a weight of at least two (2) tons and made with marine grade concrete with a minimum strength of 4,000 psi. Each module is to consist of concrete with no exposed metal framework and designed with multiple openings of various sizes all the way through the outer surface to allow for water circulation and access by fish. Open-bottom pre-fabricated modules may not be used unless each module has a top opening sufficiently large to allow for turtle escapement (additional details are set forth below).

The Modules shall be deployed so as to construct three (3) reef complexes in the Buddy Ward permit site (specific location is set forth below) offshore of Apalachicola, Florida. The location and allocation of the artificial reef modules are as specified in the deployment plan (see Attachment B which includes graphics).

The specifications for the artificial reef modules will be described in subsequent paragraphs. Available funds for this project are \$70,000.00. Contractors must submit proposals for what they can construct and deploy as specified in the deployment plan for the total of \$70,000.00. Contractor selection will be administered through the criteria outlined in the below request for proposal process.

The specified artificial reef modules are to be deployed in one (1) artificial reef permit area known as the Buddy Ward permit site located offshore of Apalachicola, Franklin County, Florida. This is an authorized artificial reef permit area with the U.S. Army Corps of Engineers and Florida Department of Environmental Protection as applicable. The permit for the Buddy Ward Permit Site is USACOE Permit Number SAJ-2018-02268 (SP-LSL) issued on 12-23-2019 and with expiration date of 12-23-2029, and FDEP Permit Number 0367204-001-EI/19 issued on 9-14-2018.

Each Contractor RFP proposal must consist of the following elements:

MINIMUM CONTRACTOR QUALIFICATIONS:

CONTRACTORS must meet the following minimum qualifications by including a response to each item below at the time of submitting a proposal:

- a. Must be on file with the Department of State in accordance with provision of Chapter 607, Florida Statutes (check the State of Florida Secretary of State website);
- b. Must not be on the federal debarment list;
- c. Must not be on the state debarment list;
- d. Must show they are competent and have the necessary resources to fulfill the conditions of the contract;
- e. Must have completed an artificial reef project within the past 5 years, anywhere in the United States;
- f. Provide proof of insurance (in accordance with Franklin County, Florida liability requirements);

MINIMUM MATERIAL STANDARDS

The project entails the manufacture and deployment of at least 25 pre-fabricated concrete artificial reef modules, or other concrete structures acceptable to the County. They will consist of at least twenty five (25) concrete prefabricated reef modules (the "Modules"), or other concrete structures acceptable to the FWC (the "Commission"), all of which must be at least four (4) feet tall with a base diameter of at least six (6) feet, a weight of at least two (2) tons and made with marine grade concrete with a minimum strength of 4,000 psi. Each module is to consist of concrete with no exposed metal framework and designed with multiple openings of various sizes all the way through the outer surface to allow for water circulation and access by fish. Open-bottom pre-fabricated modules may not be used unless each module has a top opening sufficiently large to allow for turtle escapement. Approved open-bottom modules include:

- a. Three-sided modules where each side of the top opening is at least 36-inches in length along its edge;
- b. Four or more sided modules where each side of the top opening is at least 40-inches in length along its side;
- c. Modules with a round opening with a diameter of at least 40-inches (oval openings are not allowed unless a 40-inch diameter circle can fit within the oval);
- d. Modules that are approved by the FWC as being turtle friendly.

4. No open-bottom modules are allowed that include additional modules, discs, or other materials stacked, placed on or immediately adjacent to the top opening, as they may prevent turtles from easily escaping.

5. All artificial reef materials shall be clean and free from dirt, asphalt, creosote, petroleum, or other hydrocarbons and toxic residues, loose free floating material or other deleterious substances.

6. Units must be capable of being deployed in an upright position on the seafloor. Any lifting lines or straps used during deployment must be temporary and removed by the Contractor prior to reimbursement. The County shall have the opportunity to evaluate the structural integrity of each pre-fabricated module proposed for use, and shall eliminate from artificial reef material consideration all badly damaged modules that would be prone to break apart during the transport and/or deployment process.

7. Reimbursement for loading, transporting and deploying the materials will be based on cost per unit basis. Materials that are placed within the boundaries of the permitted area, completely intact and in an upright position will be reimbursed at the full unit cost. Materials that are damaged during loading, transport or deployment operations will be reimbursed based on the liquidated damage schedule set forth below.

LOADING AND TRANSPORTATION

8. Artificial reef materials will be loaded using a suitable means of conveyance for transportation to a staging area site and loading onto a barge or other suitable vessel for offshore transportation to the designated artificial reef site. Offshore transportation shall be provided by a sufficiently powered transport or towing vessel, and shall include the necessary personnel and equipment to safely transport and deploy the reef material. Reef material loaded on to the transporting vessel must be properly secured in compliance with Coast Guard standards to allow for its safe transport to the reef construction site.

DEPLOYMENT AND MATERIALS PLACEMENT

9. During the deployment of the artificial reef material, the transport vessel must be securely in place with minimal movement (less than 50 feet) to ensure accurate placement of each concrete module on the bottom. Material must be arranged to provide habitat complexity as well as provide sand bottom forage area opportunities.

10. Any machinery used to move and deploy the reef materials (Modules) should be sufficiently powered/maneuverable and capably operated to ensure timely, effective and safe offloading of materials. The tug or transport vessel shall meet all U.S. Coast Guard certification and safety requirements, be equipped with a working, accurate Global Positioning System (GPS) unit and other marine electronics including a working VHF radio. Effective and reliable communications shall exist at all times between the transport vessel, and the County or its designated agent observer on site.

11. Deployment operations will only be initiated when sea height in the operations area is no greater than two to four feet as forecast by the nearest NOAA weather office. Either the County, Its' designated observer (including but not limited to the Apalachicola Artificial Reef Association a/k/a the "AARA") or the subcontractor's vessel captain reserves the right to suspend off-loading operations if positioning and other deployment objectives, including safety of personnel and equipment, are not being met.

12. At least 25 pre-fabricated reef modules will be strategically placed to create three patch reefs within the Buddy Ward permitted area at the coordinates listed in Table 1. The pre-fabricated reef modules will be carefully spaced at least ten feet apart and no more than 50 feet apart to avoid potential damage while still providing one cohesive patch reef.

Table 1

PATCH REEF #	LATITUDE	LONGITUDE
1	29° 29.144' N	84° 56.031' W
2	29° 29.144' N	84° 55.763' W
3	29° 29.144' N	84° 55.494' W

13. The minimum vertical clearance of 25 feet shall be maintained above the highest point of the reef material in the Buddy Ward permitted site (in accordance with the special conditions of the US Army Corps of Engineers permit number SAJ-2018-02268).

14. The Contractor shall be responsible for the temporary marking of the reef deployment location in advance of reef materials deployment. The marker(s) shall be buoys of sufficient size and color to be clearly visible to the tug captain, and sufficiently anchored and with sufficient scope so that they will not drift off the designated deployment site prior to deployment. The County will not pay for materials placed outside the permit area as described above. Precise GPS placement of marker buoys that do not shift position with time are important to ensure the reef is constructed within the permitted area.

15. The Contractor shall confirm the GPS coordinates of the individual placements as well as the maximum vertical relief of the constructed reefs using a fathometer after the reef construction has been completed.

16. The Contractor shall have on site current nautical charts of the deployment area, with the permitted site indicated on the chart. The proposed patch reef coordinates and the corner coordinates of the reef site will also be in possession of the Contractor when on site. The Contractor shall also be in possession of a copy of the Army Corps permit for the area where the deployments are taking place. The Contractor shall be responsible for ensuring that all permit condition terms are complied with.

17. The Contractor shall be prepared to remove any floating debris that might occur during deployment. Having boat hooks, dip nets, and other equipment on board to enable efficient collection of unanticipated floating debris is strongly encouraged. The Contractor shall be responsible for ensuring that any floating debris discovered during deployment operations (e.g., wood, floating line, aluminum cans, plastic bottles, or other floating materials) shall be collected and transported back to land for proper disposal.

LIABILITY AND RESPONSIBILITY FOR REEF MATERIALS

18. Upon initiation of the handling and movement of these artificial reef materials by the County's subcontractor, all liability, risk of loss and responsibility for the safe handling, storage,

transportation and deployment of the materials shall be borne by the subcontractor. This liability, assumption of risk and responsibility shall remain with the subcontractor until the materials are deployed at the Buddy Ward permitted reef site.

DEPLOYMENT PATTERN STANDARDS

During the deployment of the artificial reef material, the transport vessel must be effectively moored through double anchoring, be spudded down, or otherwise be held securely in place with minimal movement (+/-20 feet) to ensure accurate placement of the concrete modules patch reef on the bottom. Material must be arranged to provide habitat complexity as well as provide sand bottom forage area opportunities. Individual reef materials should not be widely scattered. As noted above, and any and all machinery used to move and deploy the reef materials should be sufficiently powered/maneuverable and capably operated to ensure timely, effective and safe off-loading of materials. The tug or transport vessel shall meet all U.S. Coast Guard certification and safety requirements, be equipped with a working, accurate Global Positioning System (GPS) unit and other marine electronics including a working VHF radio.

Also as noted above, materials (the Modules) proposed must be deployed within the Buddy Ward permitted area. The bidder shall state the number of proposed modules in their bid response. Where multiple modules are deployed at a single location, the modules are to be placed at least ten (10) feet apart and no more than fifty (50) feet apart to avoid stacking or otherwise contacting each other. The modules shall not be widely scattered within each deployment location.

CALENDAR OF EVENTS

It is desired that the project construction be accomplished within 120 days of contract award or Notice to Proceed. Project construction must be completed prior to **August 1, 2021**. No compensation will be made for any work completed after this date.

ECONOMY OF PRESENTATION

CONTRACTOR's proposals shall be prepared simply and economically, providing a straightforward, concise delineation of **CONTRACTOR's** capabilities to satisfy the requirement of the RFP. Elaborate binding, colored displays, and promotional material are not desired; however, technical literature may be included as attachments to the proposal. Emphasis in each proposal must be on completeness and clarity of content. In order to expedite the evaluation of proposals, it is essential that **CONTRACTORS** follow the format and instructions contained in the RFP. **CONTRACTORS** must also provide electronic copies of their bids/documents/presentations/proposals on CD/DVD or flash media (i.e. USB flash media) with their submissions.

PROPOSAL CRITERIA/FORMAT

The **CONTRACTOR** shall develop as part of the proposal, in draft form, a detailed project plan for the procurement, labor, construction, staging, transport and deployment on which the

CONTRACTOR intends to bid. The **CONTRACTOR** must provide as part of the proposed project plan the following:

1) Material Specifications – Total 25 point value

Describe detailed specifications of the materials proposed to be deployed. This information will include but not be limited to:

- a. *Detailed description and inventory of material.* Describe the material composition and the designed habitat performance. Provide an itemized list and dimensions of each category of material type to be deployed. Those module designs that more closely match or exceed the specifications in this attachment will be graded higher.
- b. *Weight per unit.* Identify the weight of each unit of material, or average weight per unit if there is variability between units.
- c. *Stability/durability.* Demonstrate stability and durability of the module type. Materials demonstrating greatest stability and durability through performance monitoring/testing will be graded higher.

2) Reef Unit Prices – Total 25 point value

Identify how many of each module design will be provided. Provide the price per unit deployed on the bottom for the total cost of the project. Module unit prices will be graded higher in comparison to proposals with modules of equal or better design, stability, and durability. Please provide this information in **Attachment B, Summary Bid Form**.

3) Available Deployment Resources – Total 10 point value

Describe the resources available to successfully complete deployment of the specified reefs as described in the deployment plan. This information will include but not be limited to: 1) source of procurement of the material; 2) the availability of the material including a production schedule if not currently in stock; 3) the staging area where the units will be kept and made available for inspection prior to deployment; 4) the specifications (load capacity, vessel type, etc.) of the vessel/barge, and crane, and other equipment that will deploy the material, and the port(s) they will be operating from; 5) the specification (load capacity, vessel type, etc.) of the tugboat and/or other support vessels that will deploy the material, and the port(s) they will be operating from. Proposals demonstrating the best capability and reliable performance will be graded higher.

4) Task Plan – Total 10 point value

Describe the step-by-step tasks of procuring, loading, moving, transporting, handling and deploying the selected materials through the time the material is placed on the bottom. Describe how the material and deployment will be in compliance with Coast Guard, U.S. Army Corps of Engineers, and State of Florida standards and requirements. Describe the proposed anchoring system and the proposed method to deploy the material. Describe any

coordination required with SUBCONTRACTORS. Proposals with the greatest detail illustrating best planning and timeliness will be graded higher.

5) Schedule of Operations – Total 10 point value

a) Provide the total number of estimated days at sea and associated vessel loading days that will be required to **accomplish the project within the desired 120 days of contract award or Notice to Proceed** or complete the project prior to **August 1, 2021, whichever comes first**;
b) Provide the number of estimated days required to manufacture the material (if not already manufactured); and c) Provide a schedule factoring in weather, availability of equipment, materials and other commitments commencing from the anticipated date of Contract execution to estimated completion of the operation. Proposals illustrating practical scheduling details and reasonably shorter timelines will be graded higher.

6) Experience and understanding – Total 20 point value

Describe your qualifications to demonstrate your ability to implement and administer the project. The **CONTRACTOR** must provide the following information: a) minimum of three reference names, addresses and phone numbers of clients for whom they have performed similar artificial reef projects; b) number of years of involvement in artificial reef construction projects and the number of artificial reef construction projects successfully completed. Contractors demonstrating the greatest amount and most recent experience will be graded higher.

DEPLOYMENT AND MATERIAL PLACEMENT

- 1) Within 30 days following contract award, the **County** shall provide the **CONTRACTOR** with a specific list of coordinates for each of the proposed modules.
- 2) **An on-site observer, designated by the County, must be present during deployment operations.** Effective and reliable communications shall exist at all times between the transport/deployment vessel, and the designated County observers on-site.
- 3) The County or its designated representative agrees to allow the **COMMISSION** to conduct on-site inspections of the modules before, during, and after the deployment.

REPORTING, PERFORMANCE, AND PUBLICATIONS

- 1) The Contractor agrees to provide the County with a minimum of three (3) weeks notice prior to any anticipated deployment date. Additional notice five (5) days prior and then continuous notification as each deployment date approaches. Furthermore, the Contractor shall be responsible for providing the County with accurate GPS coordinates for each deployed module within fourteen (14) days after the deployment.
- 2) As a minimum, any published articles related to this artificial reef activity shall reflect sponsorship as follows: "Sponsored by the Apalachicola Artificial Reef Association, the

Franklin County Board of County Commissioners, the State of Florida, the Fish and Wildlife Conservation Commission, and USFWS Federal Aid in Sport Fish Restoration Program". If the sponsorship reference is in written material, the words "State of Florida, Fish and Wildlife Conservation Commission" shall appear in the same size letters or type as the name of the Grantee's organization.

- 3) Proposers must complete **Attachment D**, Certification Regarding Debarments, Suspension, Ineligibility and Voluntary Exclusion-Lower Tier Federally Funded Transactions.
- 4) The **CONTRACTOR** shall comply with all applicable Federal, State and local rules and regulations in providing services to the County under this Agreement, including the general and special conditions specified in any permits issued by the U. S. Army Corps of Engineers, Florida Department of Environmental Protection, or the Florida Fish & Wildlife Commission. The **CONTRACTOR** acknowledges that this requirement includes compliance with all applicable Federal, State and local health and safety rules and regulations.
- 5) The **CONTRACTOR** is required to be in compliance with the following Federal employment guidelines when employing individuals with funds obtained through this contract:
 - A. Title 42, United States Code Section 2000d (Section 601, Title VI, Civil Rights Act of 1964 as amended)
 - B. Title 29, United States Code Section 794 (Section 504, Rehabilitation Act of 1973, as amended)
 - C. Title 20, United States Code Section 1681 (Section 901, Title IX, Public Law 92-318, prohibiting discrimination of the basis of sex)
 - D. Title 42, United States Code (Section 6101 Title II of Public Law 94-135, prohibiting discrimination on the basis of age)
 - E. Executive Order 11246, entitled "Equal Employment Opportunity", as amended by Executive Order 11375 and as supplemented in Department of Labor Regulations (41 CFR Part 60)
 - F. Under Title 40, United States Code Section 276a to a-7 (as supplemented by Department of Labor Regulations, 29 CFR, Part 5), **CONTRACTORS** shall be required to pay wages to laborers and mechanics at a rate not less than the minimum wages specified in a wage determination made by the Secretary of labor. In addition, **CONTRACTORS** shall be required to pay wages not less often than once a week.

LIQUIDATED DAMAGES

1. If modules are damaged during deployment, liquidated damages may be assessed giving the **County** the option of reducing payment for any misplaced, disoriented, cracked or broken modules documented during the **County's** post-deployment surveys. The **County** will report liquidated damages to the **CONTRACTOR** using the assigned unique identifier number within 15 days of material deployment. Claims for liquidated damages may only be applied to the specific modules documented by the **County** within the 15-day inspection period. Modules not inspected within the 15-day inspection period will not be eligible for liquidated damages. Liquidated damages may be applied per unit according to the liquidated damages schedule (Table 1). Damages can be cumulative; for example, if a unit is found to be lying on its side and was cracked during handling that unit's price will be reduced by 20%.

Table 1: Schedule of liquidated damages for misplaced, disoriented, cracked or broken modules documented during the post-deployment surveys.

Liquidated Damages (PER UNIT)		Reduction
1	Unit deployed intact but not lying upright	40%
2	Unit cracked during handling but is still intact	10%
3	Unit is broken with up to 10% of the material no longer intact	10%
4	Unit is broken with up to 20% of the material no longer intact	20%
5	Unit is broken with up to 30% of the material no longer intact	30%
6	Unit is broken with up to 40% of the material no longer intact	40%
7	Unit is broken with more than 40% of the material no longer intact	100%
8	Unit was deployed outside of the permitted area.	100%

PROHIBITION OF UNAUTHORIZED ALIENS In accordance with Executive Order 96-236, the Commission shall consider the employment by the County/CONTRACTOR of unauthorized aliens a violation of sub-section 274A(a) of the Immigration and Nationality Act. Such violation shall be cause for unilateral cancellation of this AGREEMENT if the County/CONTRACTOR knowingly employs unauthorized aliens.

EXPERIENCE List below, or as an attachment, any previous experience in artificial reef preparation and experience. List references, if available.

Figure -1

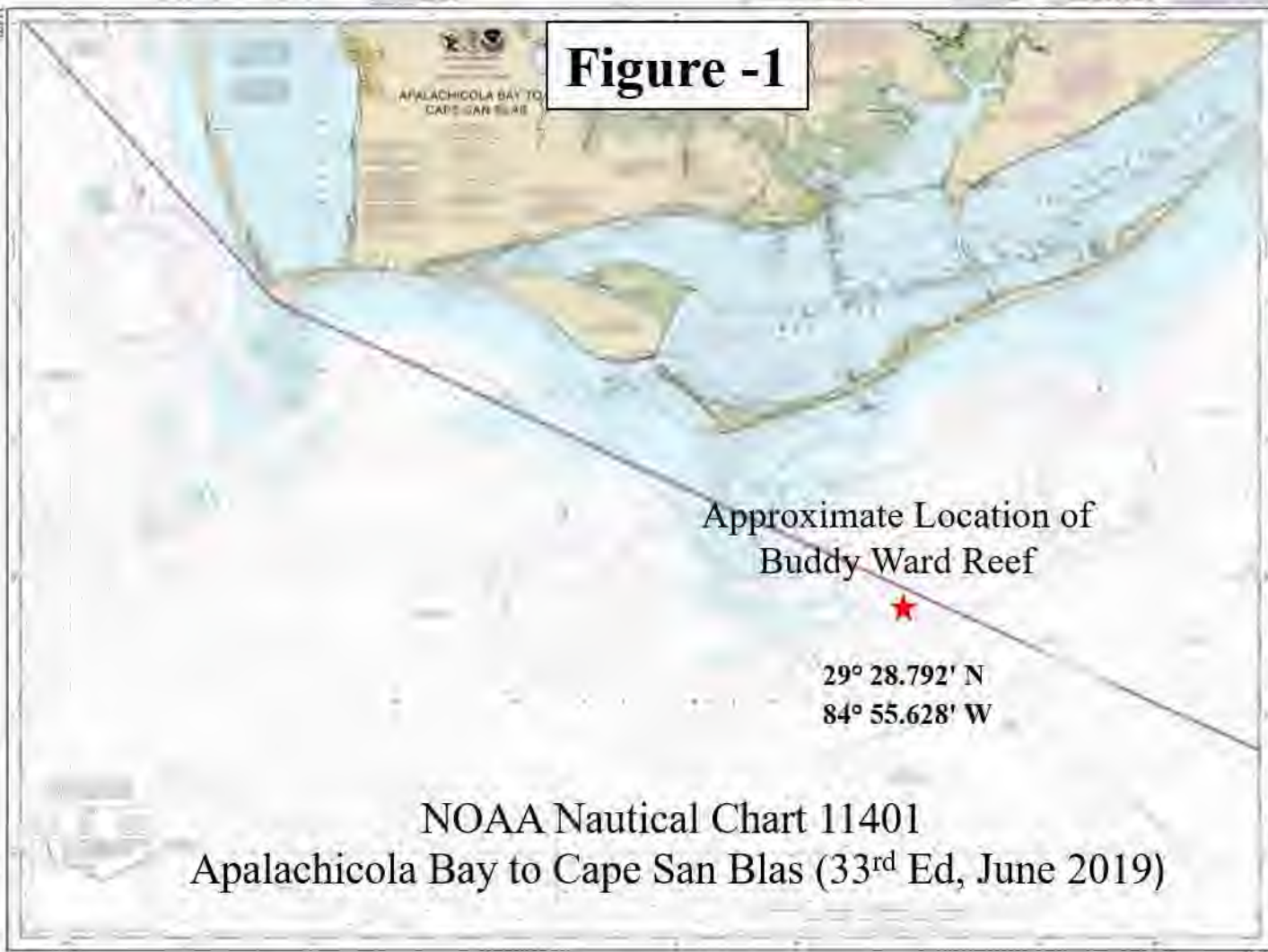

NOAA Nautical Chart 11401
Apalachicola Bay to Cape San Blas (33rd Ed, June 2019)

Figure -2



Buddy Ward Reef Nearest Passes Chart



Scale 1:20000

Scale of the

Figure -3



856.5 Acres
42 ft average depth
25 ft clearance

Florida Waters Boundary

Buddy Ward Reef Permitted Site

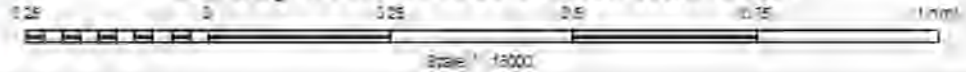
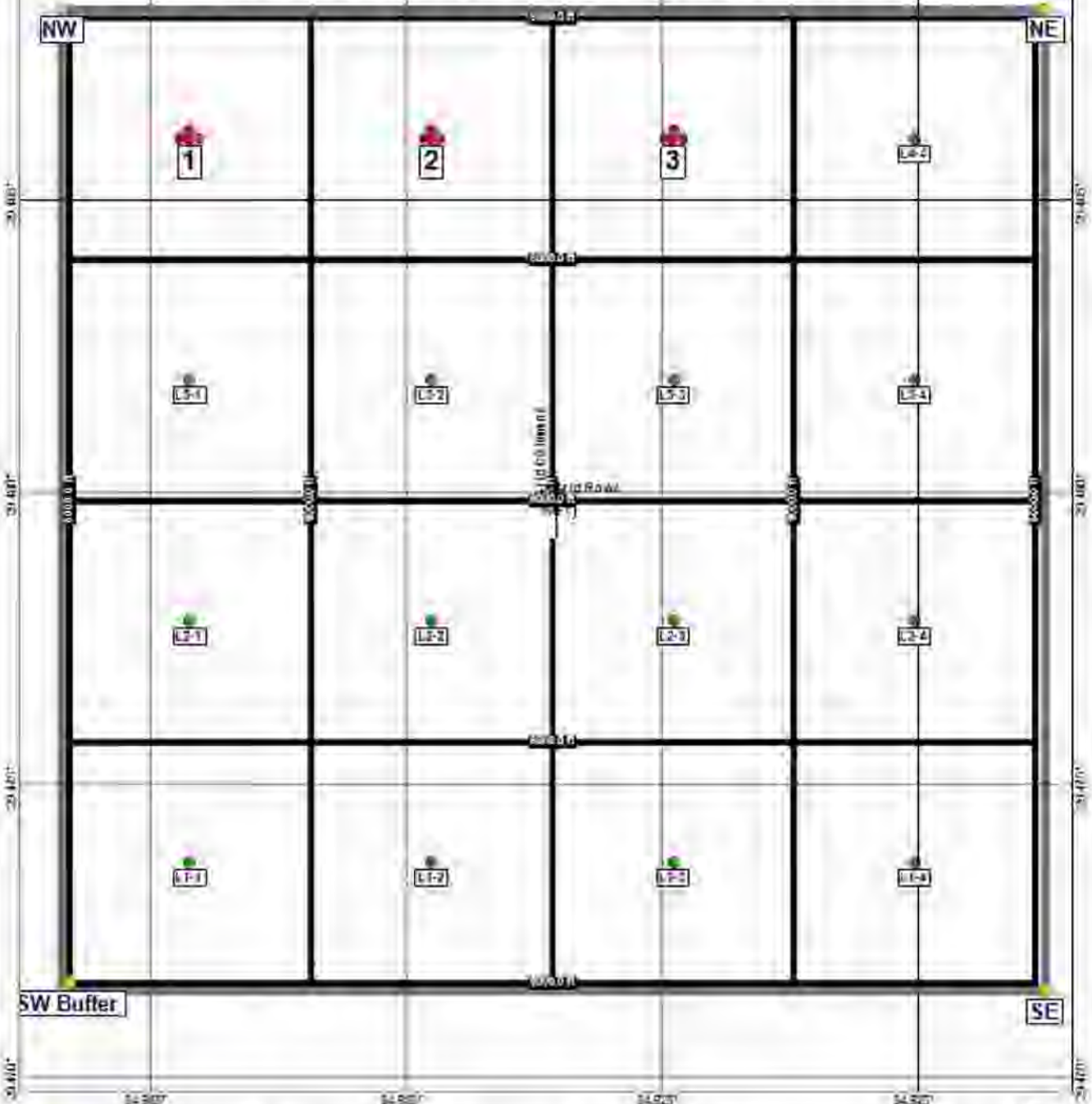
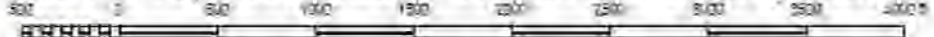

Figure -4

Patch Reefs 1, 2 and 3 – 2020 FWC Grant



2021- Proposed Buddy Ward Reef Deployments



Scale 1:9000



Figure -5

Patch reef #1

7 Units Total

3 in center

4 satellite

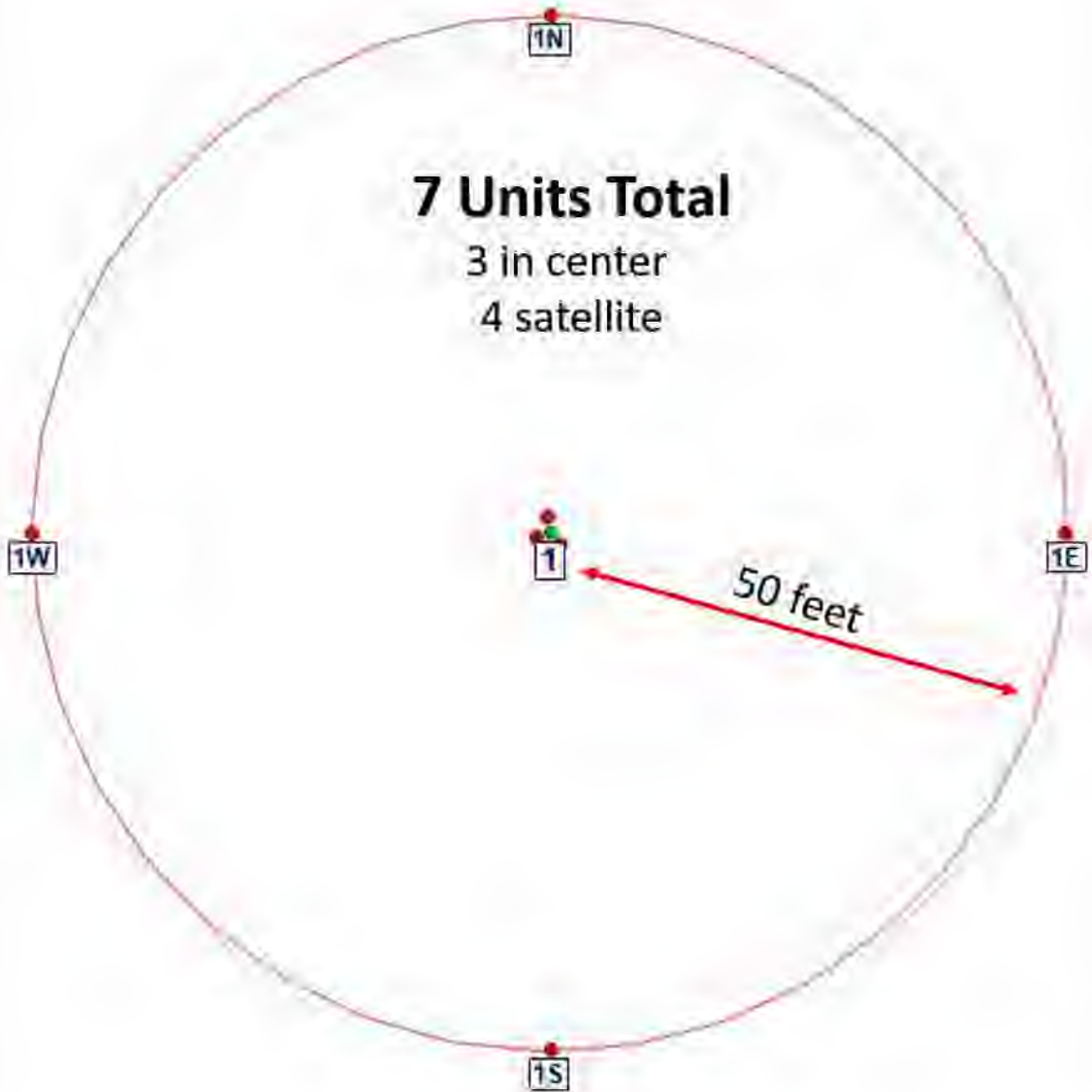

Patch Reef #1

2021- Proposed Buddy Ward Reef Deployments



Scale = 1:100



Attachment C

CONFLICT OF INTEREST DISCLOSURE FORM

For purposes of determining any possible conflict of interest, all proposers/proposers, must disclose if any Franklin County, Florida employee(s), elected officials(s), of if any of its agencies is also an owner, corporate officer, agency, employee, etc., of their business.

Indicate either "yes" (an employee, elected official, or agency is also associated with your business), or "no". If yes, give person(s) name(s) and position(s) with your business.

YES _____ NO _____

NAME(S)	POSITION(S)	FIRM NAME:
_____	_____	_____
_____	_____	_____
_____	_____	_____

BY (PRINTED): _____

BY (SIGNATURE): _____

TITLE: _____

ADDRESS: _____

PHONE NO. _____

E-MAIL _____

Attachment D

CERTIFICATIONS AND ASSURANCES

The County will not enter this Agreement unless Contractor completes the CERTIFICATIONS AND ASSURANCES contained in this Attachment. In performance of this Agreement, Contractor provides the following certifications and assurances:

- A. Debarment and Suspension Certification (2 CFR Part 1400)
- B. Certification Regarding Lobbying (31 U.S.C. 1352)
- C. Certification Regarding Public Entity Crimes (section 287.133, F.S.)
- D. Certification Regarding Drug-Free Workplace Requirements (41 U.S.C. 701 et. seq.) (as applicable to recipients and sub-recipients of federal financial assistance)
- E. Certification Regarding the Scrutinized Companies List (section 287.135, F.S.) (as applicable)

A. CERTIFICATION REGARDING DEBARMENT, SUSPENSION, AND OTHER RESPONSIBILITY MATTERS – PRIMARY COVERED TRANSACTION.

The undersigned Contractor certifies to the best of its knowledge and belief, that it and its principals:

1. Are not presently debarred, suspended, proposed for debarment, declared ineligible, or voluntarily excluded from covered transactions by a Federal department or agency;
2. Have not within a three-year period preceding this Agreement been convicted of or had a civil judgment rendered against them for commission of fraud or a criminal offense in connection with obtaining, attempting to obtain, or performing a public (Federal, State, or local) transaction or contract under a public transaction; violation of Federal or State antitrust statutes or commission of embezzlement, theft, forgery, bribery, falsification or destruction of records, making false statements, or receiving stolen property;
3. Are not presently indicted or otherwise criminally or civilly charged by a government entity (Federal, State or local) with commission of any of the offenses enumerated in paragraph A.2. of this certification; and/or
4. Have not within a three-year period preceding this application/proposal had one or more public transactions (Federal, State, or local) terminated for cause of default.

If Contractor is unable to certify to any of the statements in this certification, Contractor shall attach an explanation to this Agreement.

B. CERTIFICATION REGARDING LOBBYING – Certification for Contracts, Grants, Loans, and Cooperative Agreements.

The undersigned Contractor certifies, to the best of his /her knowledge and belief, that: 12/14/2020 3 No Federal appropriated funds have been paid or will be paid, by or on behalf of the undersigned, to any person for influencing or attempting to influence an officer or employee of Congress, or an employee of a Member of Congress in connection with the awarding of any Federal contract, the making of any Federal

grant, the making of any Federal loan, the entering into of any cooperative agreement, and the extension, continuation, renewal, amendment or modification of any Federal contract, grant, loan or cooperative agreement.

If any funds other than Federal appropriated funds have been paid or will be paid to any person for influencing or attempting to influence an officer or employee of any agency, a Member of Congress, an officer or employees of Congress, or employee of a Member of Congress in connection with a Federal contract, grant, loan, or cooperative agreement, the undersigned shall also complete and submit Standard Form – LLL, “Disclosure Form to Report Lobbying,” in accordance with its instructions.

The undersigned shall require that language of this certification be included in the documents for all subcontracts at all tiers (including subcontracts, sub-grants and contracts under grants, loans and cooperative agreements) and that all sub-recipients and contractors shall certify and disclose accordingly.

This certification is a material representation of fact upon which reliance was placed when this Grant was made or entered into. Submission of this certification is a prerequisite for making or entering into this Agreement imposed by 31 U.S.C. 1352. Any person who fails to file the required certification shall be subject to a civil penalty of not less than \$10,000 and not more than \$100,000 for each such failure.

C. CERTIFICATION REGARDING PUBLIC ENTITY CRIMES, SECTION 287.133, F.S.:

Contractor hereby certifies that neither it, nor any person or affiliate of Contractor, has been convicted of a Public Entity Crime as defined in section 287.133, F.S., nor placed on the convicted vendor list.

Contractor understands and agrees that it is required to inform the City immediately upon any change of circumstances regarding this status.

D. CERTIFICATION REGARDING DRUG-FREE WORKPLACE REQUIREMENTS

(If Contractor is a Recipient of Sub-recipient of Federal Financial Assistance)

Pursuant to the Drug-Free Workplace Act of 1988, the undersigned attests and certifies that the Grantee (if not an individual) will provide a drug-free workplace by the following actions:

1. Publishing a statement notifying employees that the unlawful manufacture, distribution, dispensing, possession or use of a controlled substance is prohibited in Contractor's workplace and specifying the actions that will be taken against employees for violation of such prohibition.
2. Establishing an ongoing drug-free awareness program to inform employees concerning:
 - a. The dangers of drug abuse in the workplace.
 - b. The policy of maintaining a drug-free workplace.
 - c. Any available drug counseling, rehabilitation and employee assistance programs.
 - d. The penalties that may be imposed upon employees for drug abuse violations occurring in the workplace. 12/14/2020 4
3. Making it a requirement that each employee to be engaged in the performance of the Agreement be given a copy of the statement required by paragraph D.1. of this certification.

4. Notifying the employee in the statement required by paragraph D.1. of this certification that, as a condition of employment under the Agreement, the employee will:

- a. Abide by the terms of the statement.
- b. Notify the employer in writing of his or her conviction for a violation of a criminal drug statute occurring in the workplace no later than five (5) calendar days after such conviction.

5. Notifying the County in writing ten (10) calendar days after receiving notice under subparagraph 4.b. from an employee or otherwise receiving actual notice of such conviction. Provide such notice of convicted employees, including position title, to every Grant Manager on whose Grant activity the convicted employee was working. The notice shall include the identification number(s) of each affected Contract or Grant.

6. Taking one of the following actions, within thirty (30) calendar days of receiving notice under subparagraph 4.b. herein, with respect to any employee who is so convicted:

- a. Taking appropriate personnel action against such an employee, up to and including termination, consistent with the requirements of the Rehabilitation Act of 1973 as amended.

- b. Requiring such employee to participate satisfactorily in drug abuse assistance or rehabilitation program approved for such purposes by a Federal, State or local, health, law enforcement, or other appropriate agency.

7. Making a good faith effort to continue to maintain a drug-free workplace through implementation of this entire certification.

If the Contractor is an individual, the Contractor certifies that:

1. As a condition of the grant, Contractor will not engage in the unlawful manufacture, distribution, dispensing, possession, or use of a controlled substance in conducting any activity with the grant; and,

2. If convicted of a criminal drug offense resulting from a violation occurring during the conduct of any grant activity, Contractor will report the conviction, in writing, within 10 calendar days of the conviction, to the County. When notice is made to such a central point, it shall include the identification number(s) of each affected grant.

E. CERTIFICATION REGARDING the SCRUTINIZED COMPANIES LISTS, SECTION 287.135, F.S.

If this Grant is in the amount of \$1 million or more, in accordance with the requirements of section 287.135, F.S., Grantee hereby certifies that it is not listed on either the Scrutinized Companies with Activities in Sudan List or the Scrutinized Companies with Activities in the Iran Petroleum Energy Sector List. Both lists are created pursuant to section 215.473, F.S. Grantee/Contractor also hereby certifies that it is not engaged in business operations in Cuba or Syria.

County/Contractor understand that pursuant to section 287.135, F.S., the submission of a false certification may subject Grantee/Contractor to civil penalties, attorney's fees, and/or costs.

If Grantee/Contractor is unable to certify to any of the statements in this certification, Grantee/Contractor shall attach an explanation to this Grant.

By signing below, Grantee/Contractor certifies the representations outlined in parts A through E above are true and correct.

Date: _____

(Signature and titles of authorized representative)

(Street)

(City, State, ZIP Code)

Attachment E
CERTIFICATION REGARDING DEBARMENTS, SUSPENSION, INELIGIBILITY AND
VOLUNTARY EXCLUSION-LOWER TIER FEDERALLY FUNDED TRANSACTIONS

Required for all contractors and subcontractors on procurement (vendor) contracts of \$100,000 or more, and for all contracts and grants with sub-recipients regardless of amount, when funded by a federal grant.

- 1. The undersigned hereby certifies that neither it nor its principals is presently debarred, suspended, proposed for debarment, declared ineligible, or voluntarily excluded from participation in this transaction by any Federal department or agency.
- 2. The undersigned also certifies that it and its principals:
 - (a) Have not within a three-year period preceding this response been convicted of or had a criminal offense in connection with obtaining, attempting to obtain, or performing a public (Federal, State or local) transaction or contract under a public transaction; violation of Federal or State anti-trust statutes or commission of embezzlement, theft, forgery, bribery, falsification or destruction of records, making false statements, or receiving stolen property.
 - (b) Are not presently indicted for or otherwise criminally or civilly charged by a governmental entity (Federal, State or local) with commission of any of the offenses enumerated in paragraph 2.(a) of this Certification; and
 - (c) Have not within a three-year period preceding this certification had one or more public transactions (Federal, State or local) terminated for cause or default.
- 3. Where the undersigned is unable to certify to any of the statements in this certification, an explanation shall be attached to this certification.

Dated this _____ day of _____, 20__.

By: _____
Authorized Signature/Contractor

Typed Name/Title

Grantee Name/Contractor Name

Street Address

Building, Suite Number

City/State/Zip Code

Area Code/Telephone Number

**INSTRUCTIONS FOR CERTIFICATION REGARDING DEBARMENT,
SUSPENSION, INELIGIBILITY AND VOLUNTARY EXCLUSION-
LOWER TIER FEDERALLY FUNDED TRANSACTIONS**

1. By signing and submitting this form, the certifying party is providing the certification set out below.
2. The certification in this clause is a material representation of fact upon which reliance was placed when this transaction was entered into. If it is later determined that the certifying party knowingly rendered an erroneous certification, in addition to other remedies available to the Federal Government, the Florida Fish and Wildlife Conservation Commission (FWC) or agencies with which this transaction originated may pursue available remedies, including suspension and/or debarment.
3. The certifying party shall provide immediate written notice to the person to which this contract is submitted if at any time the certifying party learns that its certification was erroneous when submitted or has become erroneous by reason of changed circumstances.
4. The terms covered transaction, debarred, suspended, ineligible, lower tier covered transaction, participant, person, primary covered transaction, principal, proposal, and voluntarily excluded, as used in this clause, have the meanings set out in the Definitions and Coverage sections of rules implementing Executive Order 12549. You may contact the person to which this contract is submitted for assistance in obtaining a copy of those regulations.
5. The certifying party agrees by submitting this contract that, should the proposed covered transaction be entered into, it shall not knowingly enter into any lower tier contract, or other covered transaction with a person who is debarred, suspended, declared ineligible, or voluntarily excluded from participation in this covered transaction, unless authorized by the FWC or agency with which this transaction originated.
6. The certifying party further agrees by executing this contract that it will include this clause titled "Certification Regarding Debarment, Suspension, Ineligibility and Voluntary Exclusion-Lower Tier Covered Transaction," without modification, in all contracts or lower tier covered transactions and in all solicitations for lower tier covered transactions.
7. A participant in a covered transaction may rely upon a certification of a prospective participant in a lower tier covered transaction that it is not debarred, suspended, ineligible, or voluntarily excluded from the covered transaction, unless it knows that the certification is erroneous. A participant may decide the method and frequency by which it determines the eligibility of its principals. Each participant may, but is not required to, check the Nonprocurement List (Telephone No. (202) 501-4740 or (202) 501-4873.)
8. Nothing contained in the foregoing shall be construed to require establishment of a system of records in order to render in good faith the certification required by this clause. The knowledge and information of a participant is not required to exceed that which is normally possessed by a prudent person in the ordinary course of business dealings.
9. Except for transactions authorized under paragraph 5 of these instructions, if a participant in a covered transaction knowingly enters into a lower tier covered transaction with a person who is suspended, debarred, ineligible, or voluntarily excluded from participation in this transaction, in addition to other remedies available to the Federal Government, the FWC or agency with which this transaction originated may pursue available remedies, including suspension and/or debarment.