

**AMENDED AND RESTATED  
HANGAR GROUND LEASE AGREEMENT  
5232, 5240, 5250, 5260, 5270 STEARMAN STREET**

**CITIES OF LOVELAND AND FORT COLLINS, COLORADO,  
acting by and through the  
NORTHERN COLORADO REGIONAL AIRPORT COMMISSION  
AND  
IC LOVELAND, LLC**

**DATED  
AUGUST 22, 2022**

**TABLE OF CONTENTS**

ARTICLE 1: TERM, OPTIONS AND RIGHT OF FIRST REFUSAL .....1  
ARTICLE 2: LEASED PREMISES .....2  
ARTICLE 3: USE OF LEASED PREMISES .....2  
ARTICLE 4: RENT .....3  
ARTICLE 5: ACCEPTANCE, CARE, MAINTENANCE, IMPROVEMENTS AND REPAIR .....5  
ARTICLE 6: ADDITIONAL OBLIGATIONS OF LESSEE .....6  
ARTICLE 7: INGRESS AND EGRESS .....8  
ARTICLE 8: INSURANCE, DAMAGE OR DESTRUCTION .....8  
ARTICLE 9: LIABILITIES AND INDEMNITIES .....9  
ARTICLE 10: LEASEHOLD MORTGAGES .....10  
ARTICLE 11: RULES AND REGULATIONS .....12  
ARTICLE 12: SIGNS .....12  
ARTICLE 13: ASSIGNMENT AND SUBLEASE .....12  
ARTICLE 14: CONDEMNATION .....13  
ARTICLE 15: NON-DISCRIMINATION .....14  
ARTICLE 16: GOVERNMENTAL REQUIREMENTS .....15  
ARTICLE 17: RIGHT OF ENTRY RESERVED .....15  
ARTICLE 18: TERMINATION .....16  
ARTICLE 19: SURRENDER AND RIGHT OF RE-ENTRY .....18  
ARTICLE 20: SERVICES TO LESSEE .....18  
ARTICLE 20: SURVIVAL OF THE OBLIGATIONS OF THE LESSEE .....19  
ARTICLE 22: USE SUBSEQUENT TO CANCELLATION OR TERMINATION .....19  
ARTICLE 23: NOTICES .....19  
ARTICLE 24: INVALID PROVISIONS .....20  
ARTICLE 25: MISCELLANEOUS PROVISIONS .....20  
ARTICLE 26: SUBORDINATION OF CLAUSES .....22  
ARTICLE 27: QUIET ENJOYMENT .....23  
ARTICLE 28: ENTIRE AGREEMENT .....23  
ARTICLE 29: CITIES' OPTION TO PURCHASE AND INTEREST IN IMPROVEMENTS .....23  
ARTICLE 30: RIGHT OF FIRST REFUSAL .....24  
ARTICLE 31: REQUIREMENTS OF DECLARATION .....25

EXHIBIT A, Description of Leased Premises

EXHIBIT B, Concept Plan

EXHIBIT C, Repayment Plan

## LEASE AGREEMENT

**THIS AMENDED AND RESTATED HANGAR GROUND LEASE AGREEMENT**, made and entered into this 22<sup>nd</sup> day of August, 2022, is by and between the Cities of Fort Collins and Loveland, Colorado (the "**Cities**") acting by and through the Northern Colorado Regional Airport Commission (the "**Commission**") and IC Loveland, LLC, a Colorado limited liability company, hereinafter called "**Lessee**."

### WITNESSETH:

**WHEREAS**, the Cities own and operate an airport known as the Northern Colorado Regional Airport located in Larimer County, Colorado, including the real property upon which the same is located, (hereinafter, the "**Airport**"); and

**WHEREAS**, the Cities and Lessee are mutually desirous of entering into this Lease Agreement (the "**Agreement**") for the use and occupancy of certain areas at the Airport; and

**WHEREAS**, the Cities desire to accommodate, promote and enhance general aviation at the Airport and Lessee desires to be assured of the Airport's continued availability as a base for aircraft; and

**WHEREAS**, Lessee is a Colorado limited liability company, which intends to be a Declarant of a condominium declaration creating a leasehold condominium ownership pursuant to the Condominium Ownership Act, C.R.S. § 38-33-101, *et seq.* (the "**Act**"), and desires to construct leasehold hangar condominiums on the Leasehold Premises, for ownership by individual Unit Owners as defined in such Act (the "**Unit Owners**"); and

**WHEREAS**, the Cities and Lessee have reached an understanding in principle, which envisions Lessee's maintenance of an existing hangar building or buildings, without cost to the Cities; and

**WHEREAS**, the Lessee recently received assignment of and assumed the existing lease originally entered into between the Cities and Homestead Hangars, LLC on October 1, 2019 (the "**Original Lease**"). The Lessee desires to bring the Original Lease into good standing through repayment of outstanding rent in addition to complying with all other terms and conditions of the Original Lease; and

**WHEREAS**, since 2019, the Cities' standard lease form has had minor modifications which are incorporated herein, primarily to address the Airport's Land Use and Design Standards which were adopted after execution of the Original Lease; and

**WHEREAS**, the parties desire to enter into this Amended and Restated Hangar Ground Lease to set forth their rights and obligations herein.

**NOW, THEREFORE**, in consideration of the premises and of the rents, covenants and conditions herein contained, the Cities do hereby lease to Lessee the area(s) of the Airport described in Article 2 hereof (the "**Leased Premises**") on to the conditions set forth below.

### **ARTICLE 1: TERM; OPTIONS; RIGHT OF FIRST REFUSAL**

**1.1** The initial term of this Agreement shall commence at 12:01 a.m. on September 1, 2022, and expire at 11:59 p.m. on August 30, 2047, a duration of twenty-five (25) years, hereinafter the "**Initial Term**," unless sooner terminated in accordance with the provisions hereof.

**1.2** Subject to the conditions set forth herein, Lessee shall have the option to extend the term of this Agreement for three (3) additional periods of five (5) years each, hereinafter the "**Extended Term(s)**," provided Lessee is not in default in the payment of any rent or in default in any other provisions

of this Agreement at the time of its exercise of any such option. Lessee may exercise each option by giving written notice to the Cities not more than eighteen (18) months, nor less than six (6) months prior to the expiration of the Initial Term or the then-current Extended Term, of Lessee's intent to exercise its option to extend. With the exception of rentals due, as set forth in Section 4.1, the terms and conditions applicable during the Initial Term of this Agreement shall remain applicable during any Extended Term. The rent escalation shall continue throughout the Initial Term and any Extended Term as provided in Article 4.

**1.3** If Lessee desires to continue occupying the Leased Premises after the expiration of all three (3) Extended Terms, Lessee may request in writing that the Cities grant a new lease agreement. Such a request shall be made by Lessee in writing and delivered to the Cities not later than one hundred twenty (120) days prior to the expiration of the last Extended Term. If: (i) if Lessee is not then in default under any provision of this Agreement; and (ii) the Cities in their discretion wish to offer to lease the Leased Premises to hangar tenants or an association of hangar tenants; and (iii) such a new lease would be consistent with the Airport's master plan then in effect and any and all federal rules, regulations, directives, guidelines or other obligations with respect to Airport, including but not limited to the "grant assurances" to the FAA ; then the Cities may, in their sole discretion, offer Lessee a new lease of the Leased Premises, under such terms and conditions as the Cities deem appropriate, including rental rates to include an assessment of fair market value of the property including the improvements thereon, and duration of the lease term and on the then-current lease form being offered by the Cities.

## **ARTICLE 2: LEASED PREMISES**

**2.1** The Leased Premises consist of the parcel of land described in **Exhibit "A"**. Without limiting the foregoing, the Cities acknowledge that the Hangars (as defined below) to be constructed upon the leased premises shall, during the term of this Agreement, be and remain the property of Lessee or any successor in interest.

## **ARTICLE 3: USE OF LEASED PREMISES**

**3.1** Lessee and its Unit Owners shall use and occupy the Leased Premises for the following purposes and for no other purpose whatsoever unless approved in writing by Cities:

**3.1.1** For the construction, installation, maintenance and operation of a hangar building (the "Hangars") to be used for the parking, storage, servicing, repair, maintenance, modification, and construction of aircraft owned or operated by Lessee or its Unit Owners. Lessee's construction, installation, maintenance and operation of the Hangars shall comply with and be subject to the requirements of the Airport Minimum Standards, including the Airport Land Use and Design Standards incorporated therein. Lessee's use of the Leased Premises, including use for storage of aircraft owned by Unaffiliated Entities, shall be of a non-commercial nature, unless a commercial use is approved by the Cities by a separate written License. The foregoing shall not preclude the subleasing of space within individual Hangar buildings to Unaffiliated Entities, so long as a License is obtained if required by the Airport's Minimum Standards then in effect. Any such License shall require compliance with Minimum Standards for the Provision of Commercial Aeronautical Activities at the Airport (the "Minimum Standards"), as they then exist or are thereafter adopted or amended by the Cities. Any such commercial use must also be consistent with the City of Loveland, Colorado, building, use and zoning regulations and requirements applicable to the Leased Premises. Lessee shall include in its Condominium Declaration governing use and operation of the Leased Premises, a provision that all Unit Owners shall cause such aircraft based at the Leased Premises to comply with noise standards established under Part 36 of Title 14 of the Code of Federal Regulations, ("FAR 36") as amended from time to time. The Leased Premises shall not be used for residential purposes.

**3.1.2** A copy of a Concept Plan for the development of the Hangars is attached as **Exhibit "B"** (the "Concept Plan"). The Cities make no representations, guarantees, or warranties

that the Leased Premises may be lawfully used for the purposes set forth in this Section 3.1. Lessee shall have the sole responsibility of obtaining all applicable permits or other governmental approvals necessary to construct and use the Leased Premises as intended herein. This Agreement is expressly conditioned upon Lessee obtaining all such permits and approvals, and the failure of Lessee to obtain any such permits or approvals within eighteen (18) months of the commencement date set forth in Section 1.1 or the failure of Lessee to maintain any such permits or approvals during the term of this Agreement shall result in termination of this Agreement pursuant to Article 18, generally, and to Section 18.9 specifically.

**3.1.3** During the term of this Agreement, Lessee and/or its Unit Owners must regularly house at least one airworthy aircraft or at least one aircraft that periodically may be in active stages of assembly or reassembly in each Hangar, use each Hangar for the primary purpose of aircraft storage, and each Hangar shall be used for Aeronautical Activities only, unless the prior written permission of the Cities is first obtained. The term "Aeronautical Activities" shall mean any activity or service that involves, makes possible, facilitates, is related to, assists in, or is required for the operation of aircraft, or which contributes to or is required for the safety of aircraft operations.

#### **ARTICLE 4: RENT**

**4.1** Lessee agrees to pay to the Cities during the Initial Term an annual rent of \$0.3227731 per square foot for the 159,648 square feet of the Leased Premises, including the building footprint, ramp, and area surrounding the building footprint, as set forth in Exhibit A, for a total of \$51,530.08 per year, subject to adjustment pursuant to Section 4.2. If Lessee exercises any option to extend the term of this Agreement under Section 1.2, annual rent per square foot for the first year of such Extended Term shall be the greater of (a) the rent determined under Section 4.2, as if the Initial Term had continued throughout such Extended Term, or (b) the then current market rates for hangar ground leases at comparable airports in the Front Range area, which shall be deemed to include the Denver Metro Area north through Cheyenne. Cities and Lessee agree to use their best efforts to agree on then current market rates, and execute a Lease Extension Agreement, within ninety (90) days after Lessee's written notice of election is received by the Cities. If the Cities and Lessee cannot agree upon the rental rates, the parties agree to submit to mediation before the Judicial Arbitrator Group of Denver, Colorado, or if it no longer exists a similar organization, to determine the rent to be paid by Lessee for the first year of the ensuing Extended Term; provided, however, that such rent shall never be lower than the rental which is due by application of subsection (a), above. The parties will each pay fifty percent (50%) of the mediator cost.

**4.2** Commencing on May 1<sup>st</sup> next occurring after the date of this Agreement, and on May 1<sup>st</sup> in each year thereafter during the remainder of the Initial Term, the annual rent shall be adjusted by multiplying the annual rent payable in the next preceding year by a fraction, the numerator of which shall be the C.P.I., as hereinafter defined, published for the previous month of December and the denominator of which shall be the C.P.I. published for the month of December which preceded the month used as the numerator. In no event shall the annual rent be reduced from that payable in a previous year. If this Agreement is executed after January 1<sup>st</sup>, such C.P.I. increase for the calendar year in which this Agreement is executed shall be prorated. If Lessee elects to exercise its option for any Extended Term, and accordingly, the rental for the first year of such Extended Term has been set on the basis of current market rates, then rental for any subsequent year of such Extended Term shall be adjusted in accordance with the C.P.I. formula set forth in this section above.

**4.2.1** The term "C.P.I." as used herein shall mean the Consumer Price Index for all Urban Consumers (CPI\_U), All items, for the Denver-Boulder-Greeley, CO as published by the Bureau of Labor Statistics of the United States Department of Labor, 1982-84 base = 100. In the event the base year is changed, the C.P.I. shall be converted to the equivalent of the base year 1982-84 = 100. In the event the Bureau of Labor Statistics ceases to publish the C.P.I., or this index, an equivalent or comparable economic index will be used.

**4.3** The annual rent payable hereunder may be paid in advance in annual installments, or shall be paid in equal monthly installments on the first day of each month in advance at the office of the Airport Manager or at such other office as may be directed in writing by the Cities. Payments due to the Cities under this Agreement shall be paid without offset. In addition to any other remedies provided in this Agreement, in the event that any rental, fee or charge set forth in this Agreement is not paid to the Cities within ten days of the date due, Lessee agrees to pay a late charge of \$50.00 for each such late payment, and default interest shall accrue on such payment from the date the payment was due, at a rate of twelve percent (12%) per annum. If any action is brought to collect any amounts due under this Agreement, the prevailing party shall be entitled to recover its reasonable attorney fees and costs incurred.

**4.4** Lessee, as additional rent, shall complete construction of Hangars and related Improvements on the Leased Premises, in accordance with plans and specifications approved by the Cities based upon the Concept Plan. The Hangars shall, collectively, be at least a total of 76,856 square feet in size and shall have a concrete or asphalt floor, with each Hangar to have at least one aircraft access door sized to accommodate an average private aircraft. Lessee shall use commercially reasonable and diligent efforts to complete construction of the Hangars and other such Improvements within the earlier of eighteen (18) months of the Cities' approval thereof or within three years from the date of this Agreement. If Lessee fails to construct the Hangars and other such Improvements in accordance with the provisions of this section, and such failure to construct is caused by force majeure or improper action of the Cities, then this Agreement may be cancelled by Lessee upon thirty (30) days notice to the Cities, in which event and as of the date of such cancellation, Lessee shall be released from any further obligations under this Agreement.

**4.5** Lessee, shall maintain a paved aircraft ramp area on the Leased Premises (the "Ramp"). The Ramp must be designed and built to specifications, and for a minimum weight bearing capacity, established by the Cities, and to connect with adjacent taxiway, ramp and/or auto parking areas, in order that a continuous and safe pavement section results. It is the responsibility of Lessee to maintain the entire Ramp area, and all other pavement areas on the Leased Premises, in a manner, which is safe and clean of debris so as not to cause danger or unsafe conditions for taxiing aircraft and Airport users. Notwithstanding the foregoing, the Cities shall be responsible for snow removal on the aircraft Ramp area excluding any parking and side lots and excluding any area within three feet (3') of any Hangar; provided, however, that priority of snow removal shall be in accordance with the Cities' Snow Removal Plan as it now exists or as it may be amended in the Cities' sole discretion. Lessee grants to users of the Airport the right to use aircraft Ramp areas on the Leased Premises from time to time for passage of aircraft on and near the adjacent taxiway.

**4.6** Subject to the provisions of Article 10, Lessee shall keep the Leased Premises, and the Hangar, Ramp and any and all structures constructed by Lessee on the Leased Premises (collectively, the "Improvements" hereinafter), free and clear of any liens and encumbrances, except as contemplated by Article 10, or unless expressly approved in writing by the Cities, and shall indemnify, hold harmless and defend the Cities from any liens and encumbrances arising out of any work performed or materials furnished by or at the direction of Lessee. In the event any lien is filed, Lessee shall do all acts necessary to discharge any lien within ten (10) days of filing, or if Lessee desires to contest any lien, then Lessee shall deposit with the Cities such security as the Cities shall reasonably demand to insure the payment of the lien claim. In the event Lessee fails to pay any lien claim when due or fails to deposit the security with the Cities, then the Cities shall have the right to expend all sums necessary to discharge the lien claim, and Lessee shall pay the Cities, as additional rental when the next rental payment is due, all sums expended by the Cities in discharging any lien, including reasonable attorneys' fees and costs, and interest at twelve percent (12%) on the sums expended by the Cities from the date of expenditure to the date of payment by Lessee.

**4.7** Lessee agrees to comply with Minimum Standards adopted by the Cities for the Airport, as they now exist or as they may hereafter be adopted or amended. Fees due under such Minimum Standards or pursuant to any License issued for commercial activities conducted in whole or part on the Leased

Premises, may be collected by the Cities as additional rent under this Agreement, in addition to any other remedies available to the Cities.

**4.8** Lessee acknowledges and agrees that there is past due rent owed under the Lease from the original lessee in the amount of \$114,307.51. Lessee and the Cities agree that Lessee shall repay such past due rent in addition to the other rent owed under this Lease with a fixed interest rate of 5.5% in twenty-eight monthly installments of \$4,321.17 due on the first of each month beginning with the month this Lease commences, with the balance to be paid in full by December 1, 2024. The full repayment plan schedule is attached as "Exhibit C." Failure to make any payment as due under this Paragraph 4.8 shall be considered an event of default on the payment of rents under this Lease.

## **ARTICLE 5: ACCEPTANCE, CARE, MAINTENANCE, IMPROVEMENTS AND REPAIR**

**5.1** Lessee acknowledges that it has inspected the Leased Premises, conducted such studies and tests thereof (including environmental tests) as it deems necessary, and accepts possession of the Leased Premises "as is" in its present condition, and, subject to all limitations imposed upon the use thereof by the rules and regulations of the Federal Aviation Administration, the rules and regulations of the Airport, and by ordinances of the Cities, admits its suitability and sufficiency for the uses permitted hereunder. The Cities represent to Lessee that, to their knowledge, the Leased Premises are free of any adverse environmental conditions and no part of the Leased Premises lies in a flood hazard area or constitutes a fresh water wetland, nor is any part of the Leased Premises within one hundred feet (100') feet of a fresh water wetland. Except as may otherwise be provided for herein, the Cities shall not be required to maintain nor to make any improvements, repairs or restoration upon or to the Leased Premises or to any of the improvements presently located thereon or placed thereon by Lessee.

**5.2** Except as provided in Section 4.5, Lessee shall, throughout the term of this Agreement, assume the entire responsibility, cost and expense, for all repair and maintenance whatsoever on the Leased Premises and all Improvements thereon in a good workmanlike manner, whether such repair or maintenance be ordinary or extraordinary, structural or otherwise. Additionally, Lessee, without limiting the generality hereof, shall:

**5.2.1** Keep at all times, in a clean and orderly condition and appearance, the Leased Premises, all Improvements thereon and all of Lessee's and/or its Unit Owners' fixtures, equipment and personal property which are located on any part of the Leased Premises. Lessee and its Unit Owners shall not park or leave, or allow to be parked, aircraft on the taxiways, ramps or pavement adjacent to any Hangar in a manner which unduly interferes with or obstructs access to other hangars or movement on adjacent taxiways.

**5.2.2** Provide and maintain on the Leased Premises all obstruction lights and similar devices, and safety equipment required by law.

**5.2.3** Take measures to prevent erosion, including but not limited to, the planting and replanting of grasses with respect to all portions of the Leased Premises not paved or built upon, if any, and in particular shall plant, maintain and replant any landscaped areas.

**5.2.4** Be responsible for the maintenance and repair of all utility services lines placed on the Leased Premises and used by Lessee exclusively, including, but not limited to, water lines, gas lines, electrical power and telephone conduits and lines, sanitary sewers and storm sewers.

**5.2.5** In the event Lessee discovers any hazardous material on the Leased Premises, it will promptly notify the Cities in writing.

**5.2.6** If extraordinary repairs or maintenance to the Improvements are required during the last five years of the Initial Term or any Extended Term of this Agreement, Lessee may elect

not to repair and/or maintain the Improvements, by giving the Cities written notice of its election. In such case, Cities shall have the option of requiring Lessee to either (a) clear the site, remove all debris and paving, stub up all utilities, and restore the site to its original cleared condition prior to commencement of construction; or (b) transfer title to the Improvements to the Cities, as is. Upon Lessee's election and compliance with this section, the Cities shall terminate this Agreement and relieve Lessee of all future rental obligations hereunder.

**5.3** Plans and specifications for each of the Improvements and all repairs (other than emergency repairs), construction, alterations, modifications, additions or replacements to the Improvements, including those made to any paving upon the Leased Premises, excluding non-structural repairs, construction, alterations, modifications, additions or replacements costing less than ten thousand dollars (\$10,000.00) shall be submitted to the Cities for approval, which approval shall not be unreasonably denied, providing the plans and specifications comply with the provisions of this Agreement, the Airport Land Use and Design Standards, as well as all applicable building, use and zoning regulations. Submittal of the above described Plans and Specifications shall also include a site plan, drainage plan, and building plan for the initial project development. The site plan shall show the location of all Improvements on the Leased Premises, including the Hangars, pavements, utilities and location of the Hangars on the site. The drainage plan must show how drainage will be handled and be approved by the Airport Manager prior to a building permit being issued by the City of Loveland. Lessee shall reimburse the Cities for all costs incurred for providing a legal survey and legal description of the Leased Premises and for a proportional share of any costs to bring road access and utilities to the Leased Premises, should the Cities agree to do so. Prior to the commencement of any construction of the Improvements Lessee shall have the Leased Premises staked by a certified surveying company to ensure all Improvements are place accurately on the Leased Premises. Within ninety (90) days of the certificate of occupancy being received, Lessee shall submit to the Airport Manager a full set of as-built record drawings of the Improvements, which among other things, depicts exact locations of all Improvements, including utilities, made on and/or off of the Leased Premises.

## **ARTICLE 6: ADDITIONAL OBLIGATIONS OF LESSEE**

**6.1** Lessee shall conduct its operations hereunder and cause each of its Unit Owners to conduct their operations in an orderly and proper manner, considering the nature of such operations, so as not to unreasonably annoy, disturb, endanger or be offensive to others.

**6.2** Further, Lessee shall take all reasonable measures:

**6.2.1** To reduce to a practicable minimum vibrations tending to damage any equipment, structure, buildings or portions of buildings.

**6.2.2** Not to produce or allow to be produced on the Airport through the operation of machinery or equipment any electrical, electronic or other disturbances that interfere with the operation by the Cities or the Federal Aviation Administration of air navigational, communication or flight equipment on the Airport or on aircraft using the Airport, or with ground transportation communications.

**6.3** Lessee shall comply and shall include covenants in its Condominium Declaration that require Unit Owners to comply with all federal, state and municipal laws, ordinances, rules, regulations and requirements, the Airport Minimum Standards, Airport security rules and regulations, and other Airport rules and regulations, as they now exist or may hereafter be amended or promulgated, and the terms of this Agreement, applicable to the Leased Premises and the Improvements thereon and its operations and activities at the Airport hereunder.

**6.4** Lessee and its Unit Owners shall commit no nuisance, waste or injury on the Leased Premises, and shall not do, or permit to be done, anything that may result in the creation, commission or maintenance of such nuisance, waste or injury on the Leased Premises.



**6.5** Lessee and its Unit Owners shall not do, nor permit to be done, anything which may interfere with the effectiveness or accessibility of the drainage system, sewerage system, fire protection system, sprinkler system, alarm system and fire hydrants and hoses, if any, installed or located on the Leased Premises.

**6.6** Lessee shall take measures and shall include covenants in its Condominium Declaration that require Unit Owners to take measures to ensure security in compliance with Federal Aviation Administration Regulations and the Airport Security Plan, as they now exist or may hereafter be amended or promulgated.

**6.7** Lessee and its Unit Owners shall not do, nor permit to be done, any act or thing which will invalidate or conflict with any fire insurance policies or regulations applicable to the Leased Premises or any part thereof; or other contiguous premises at the Airport.

**6.8** Lessee and its Unit Owners shall not install, maintain, operate or permit the installation, maintenance or operation of any restaurant, kitchen, stand or other establishment of any type for the sale of food or of any vending machines or device designed to dispense or sell merchandise or services of any kind to the general public, unless all required development approvals and permits for that activity are first obtained from the Cities.

**6.9** Except for uses permitted under Article 3 to be performed by Lessee, or Unit Owners or their tenants, Lessee and its Unit Owners shall not provide or allow to be provided aircraft maintenance work, flight instruction of any sort, air taxi, aircraft charter or aircraft leasing of any sort on the Leased Premises, for commercial purposes, without all required development approvals, and a License from the Cities if and as required by the Airport's Minimum Standards then in effect.

**6.10** Lessee will conduct its operations, and shall include covenants in its Condominium Declaration that require each of its Unit Owners to conduct their operations, in such a manner as to keep the noise produced by aircraft engines and component parts thereof, and any other noise, to a minimum, by such methods as are practicable, considering the extent and type of the operations of Lessee and/or its Unit Owners, and the limitations of federal law. In addition, Lessee and its Unit Owners will employ the maximum amount of noise arresting and noise reducing devices that are available and economically practicable, considering the extent of their operations, but in no event less than those devices required by federal, state or local law. In its use of the Leased Premises, Lessee and its Unit Owners shall take all possible care, exercise caution and use commercially reasonable efforts to minimize prop or jet blast interference and prevent jet blast damage to aircraft operating on taxiways and to buildings, structures and roadways, now located on or which in the future may be located on areas adjacent to the Leased Premises. In the event the Cities determine that Lessee or any of its Unit Owners has not curbed the prop or jet blast interference and/or damage, Lessee hereby covenants and agrees to erect and maintain at its own expense or to cause the Unit Owners or Condominium Association to erect and maintain at their expense such structure or structures as may be necessary to prevent prop or jet blast interference, subject, however, to the prior written approval of the Cities as to type, manner and method of construction.

**6.11** Lessee shall not store nor permit the storage of disabled aircraft or any equipment or materials outside of the Hangars constructed on the Leased Premises, without the written approval of the Cities.

**6.12** On forms and at the frequency prescribed by the Airport Manager, and with respect to each aircraft stored on the Leased Premises, Lessee shall provide the Cities with the (a) make and model, (b) N-number, and (3) identity and address of the registered owner. This requirement shall apply to aircraft whether owned by Lessee or another party, and regardless of whether its storage is subject to the Minimum Standards.

## **ARTICLE 7: INGRESS AND EGRESS**

**7.1** Lessee and its Unit Owners shall have the right of ingress and egress between the Leased Premises and the public landing areas at the Airport by means of connecting taxiways; and between the Leased Premises and the entrance(s) to the Airport by means of connecting paved roads. Lessee and its Unit Owners shall have the right to use the public runways and public aviation aids at all times during which they are open to the public. Such rights of ingress, egress and use shall be in common with others having rights of use and passage thereon.

**7.1.1** If, at the time of entering into this Agreement, access to the Leased Premises is not available on existing taxiways and/or roadways, then such taxiways and/or roadways necessary for Lessee's use and occupancy shall be constructed at the sole expense of Lessee, in accordance with construction specifications and design criteria approved by the Cities for the uses contemplated by Lessee. The Cities shall have no obligation whatsoever for the cost of these improvements. Upon completion of construction, Lessee shall certify that the taxiways and/or roadways so constructed have been built to such specifications and criteria, and those portions of any such taxiways and/or roads located off the Leased Premises shall be conveyed and dedicated to the Cities, which shall accept them for maintenance. Upon such conveyance and dedication, Lessee shall warrant that the same shall be free of defects in materials and workmanship for a period of not less than two (2) years after the date of such conveyance and dedication. Such warranty shall be backed by a warranty bond or another form of security instrument, satisfactory to the Cities in their sole discretion, in the amount of not less than fifteen-percent (15%) of the construction cost of the improvements warranted.

**7.2** The use of any such roadways or taxiways shall be subject to the Rules and Regulations of the Airport, which are now in effect or which may hereafter be promulgated, and subject to temporary closure, provided, however, that any closure shall be only for reasonably necessary or unique circumstances, and provided that fourteen (14) days prior written notice will be given to Lessee relevant to any closure, unless such closure is necessary due to emergency. Lessee, for itself and its authorized subtenants, hereby releases and discharges the Cities, the Commission, their officers, employees and agents, and all their respective successors and assigns, of and from any and all claims, demands, or causes of action which Lessee or its authorized subtenants may now or at any time hereafter have against any of the foregoing, arising or alleged to arise out of the closing of any street, roadway or other area, provided that other reasonable means of access to the Leased Premises remain available to Lessee without cost to Lessee, unless otherwise mandated by emergency safety considerations or lawful exercise of the police power. Lessee shall not do or permit anything to be done which will interfere with the free access and passage of others to space adjacent to the Leased Premises or in any streets or roadways on the Airport.

## **ARTICLE 8: INSURANCE, DAMAGE OR DESTRUCTION**

**8.1** Lessee, at its sole cost and expense, shall procure and maintain throughout the term of this Agreement insurance protection for all risk coverage on the Improvements which are part of the Leased Premises, to the extent of one hundred percent (100%) of the actual replacement cost thereof. Such insurance shall be written by insurers acceptable to Cities. The insurance shall provide for ten (10) days' notice of cancellation or material change, certified mail, return receipt requested, to the Cities, Attention: Airport Manager.

**8.1.1** The above stated property insurance shall be for the benefit and to safeguard the interests of the Cities and Lessee.

**8.1.2** Lessee shall settle all losses with the insurance carrier. Lessee shall consult with the Cities and use its best efforts to obtain a settlement that covers the cost of repairing or rebuilding the Improvements.

**8.1.3** Lessee shall provide certificates of insurance, in a form acceptable to the Cities and marked "premium paid" evidencing existence of all insurance required to be maintained prior to occupancy of the Improvements. Upon the failure of Lessee to maintain such insurance as above provided, the Cities, at their option, may take out such insurance and charge the cost thereof to Lessee, which shall be payable on demand, or may give notice of default pursuant to Article 18.

**8.2** In the event the Improvements and any subsequent improvements, insurable or uninsurable, on the Leased Premises are damaged or destroyed to the extent that they are unusable by Lessee for the purposes for which they were used prior to such damage, or same are destroyed, Lessee shall promptly repair and reconstruct the Improvements substantially as they were immediately prior to such casualty or in a new or modified design, subject to the provisions of Article 5 hereof and applicable building codes and the Airport Land Use and Design Standards, existing at the time of repairing or rebuilding. If the aforesaid damage or destruction occurs in the last five years of the Initial term or any option term of this Agreement, Lessee may elect not to repair and reconstruct the Improvements, subject to the following terms and conditions:

**8.2.1** Lessee shall give the Cities written notice of its election not to repair and reconstruct the Improvements within ninety (90) days of the date upon which the Improvements were damaged or destroyed. In such case, the Cities shall have the option of either:

**8.2.1.1** Requiring Lessee to clear the site, remove all debris and paving, stub up all utilities, and restore the site to its original cleared condition prior to commencement of construction; in which case Lessee shall retain all insurance proceeds above those necessary to fund such site restoration; or

**8.2.1.2** Taking title to the damaged Improvements, as is, in which case Lessee shall assign to and the Cities shall retain all insurance coverage and proceeds.

**8.2.3** Upon Lessee's notice under Section 8.2.1 hereof and Lessee's compliance with the provisions of Sections 8.2.1.1 or 8.2.1.2 hereof, the Cities shall terminate this Agreement and relieve Lessee of all future rental obligations hereunder.

**8.3** All policies of insurance required herein shall name the Cities as additional insureds.

**8.4** Whenever in this Agreement, provision is made for the carrying of any insurance, it shall be deemed that such provision is complied with if such insurance otherwise complying with such provision is carried under a blanket policy or policies covering the Leased Premises as well as other properties.

**8.5** Lessee shall not violate, nor permit to be violated, any of the conditions of any of the said policies; and shall perform and satisfy, or cause to be satisfied, the requirements of the companies writing such policies.

## **ARTICLE 9: LIABILITIES AND INDEMNITIES**

**9.1** The Cities and the Commission shall not in any way be liable for any cost, liability, damage or injury including cost of suit and expenses of legal services, claimed or recovered by any person whomsoever, or occurring on the Leased Premises, or the Airport, or as a result of any operations, works, acts or omissions performed on the Leased Premises, or the Airport, by Lessee, its agents, servants, employees or authorized tenants, or their guests or invitees. Lessee, and each of its Unit Owners, shall not in any way be liable for any cost, liability, damage or injury including cost of suit and expenses of legal services, claimed or recovered by any person whomsoever, or occurring on the Leased Premises, or the Airport, or as a result of any operations, works, acts, or commission performed on the Leased Premises, or

the Airport, solely by the Cities and the Commission, their agents, servants, employees or authorized tenants, or their guests or invitees.

**9.2** Lessee and its Unit Owners agree to indemnify, save and hold harmless, the Cities and the Commission, their officers, agents, servants and employees, of and from any and all costs, liability, damage and expense, including costs of suit and reasonable expenses of legal services, claimed or recovered, justly or unjustly, falsely, fraudulently or frivolously, by any person, firm or corporation by reason of injury to, or death of, any person or persons, including Cities' personnel, and damage to, destruction or loss of use of any property, including Cities' property, directly or indirectly arising from, or resulting from, any operations, works, acts or omissions of Lessee, its agents, servants, employees, contractors, or authorized tenants. Upon the filing with the Cities by anyone of a claim for damages arising out of incidents for which Lessee herein agrees to indemnify and hold the Cities harmless, the Cities shall notify Lessee of such claim and in the event that Lessee does not settle or compromise such claim, then Lessee shall undertake the legal defense of such claim on behalf of Lessee and the Cities. It is specifically agreed, however, that the Cities at their own cost and expense, may participate in the legal defense of any such claim. Any final judgment rendered against the Cities for any cause for which Lessee is liable shall be conclusive against Lessee as to liability and amount upon the expiration of the time for appeal.

**9.3** Lessee shall procure and keep in force during the term of the Lease policies of Comprehensive General Liability insurance insuring Lessee and the Cities against any liability for personal injury, bodily injury, death, or property damage arising out of the subject of this Agreement with a combined single limit of at least one million dollars or with a limit of not less than the maximum amount that may be recovered against the Cities under the Colorado Governmental Immunity Act, whichever is greater. No such policies shall be cancelable or subject to reduction in coverage limits or other modification except after ten (10) days prior written notice to the Cities. The policies shall be for the mutual and joint benefit and protection of Lessee and the Cities and such policies shall contain a provision that the Cities, although named as an insured, shall nevertheless be entitled to recovery under said policies for any loss occasioned to it, its servants, agents, citizens, and employees by reason of negligence of Lessee. Lessee shall provide certificates of insurance, in a form acceptable to the Cities and marked "premium paid" evidencing existence of all insurance required to be maintained prior to the commencement of the Agreement.

**9.4** Lessee represents that it is the owner of or fully authorized to use any and all services, processes, machines, articles, marks, names or slogans used by it in its operations under or in any way connected with this Agreement. Lessee agrees to save and hold the Cities, their officers, employees, agents and representatives free and harmless of and from any loss, liability, expense, suit or claim for damages in connection with any actual or alleged infringement of any patent, trademark or copyright, or arising from any alleged or actual unfair competition or other similar claim arising out of the operations of Lessee under or in any way connected with this Agreement.

## **ARTICLE 10: LEASEHOLD MORTGAGES**

**10.1** If Lessee shall execute a Leasehold Mortgage of its leasehold estate, or if a Unit Owner shall grant a similar interest, to an entity which is not directly or indirectly owned or controlled by, or is not under common ownership or control with Lessee or Unit owner, as the case may be, (collectively, an "Unaffiliated Entity"), and if the holder of such Leasehold Mortgage shall provide the Cities through the Commission or Airport Manager with notice in the manner described in Article 13 with notice of such Leasehold Mortgage together with a true copy of such Leasehold Mortgage and the name and address of the Mortgagee, then following receipt of such notice by the Cities, the provisions of this Article 10 shall apply in respect to such Leasehold Mortgage.

**10.2** The term "Leasehold Mortgage" as used in this Agreement shall include, but not be limited to, a mortgage, a deed of trust, a deed to secure debt, or other security instrument by which Lessee's leasehold estate is mortgaged, conveyed, assigned, or otherwise transferred, to secure a debt or other obligation, in connection with the construction contemplated by Sections 4.4 through 4.5, above.

**10.3** The Cities, upon providing Lessee any notice of default under this Agreement or termination of this Agreement, shall at the same time provide a copy of such notice to the Leasehold Mortgagee by first class U.S. mail at the address specified in the notice given pursuant to Section 10.1, above. Such Leasehold Mortgagee shall have the additional periods of time specified in Section 10.4 hereof to remedy, commence remedying, or cause to be remedied the default or acts or omissions which are specified in any such notice. The Cities shall accept such performance by or at the instigation of such Leasehold Mortgagee as if the same had been done by Lessee.

**10.4** Anything contained in this Agreement to the contrary notwithstanding, if any default shall occur which entitles the Cities to terminate this Agreement, the Cities shall have no right to terminate this Agreement unless, following the expiration of the period of time given Lessee to cure such default or the act or omission which gave rise to such default, the Leasehold Mortgagee is given an additional period of thirty (30) days to:

**10.4.1** Notify the Cities of such Leasehold Mortgagee's desire to defeat such Termination Notice; and

**10.4.2** Pay or cause to be paid all rent, additional rent, and other payments then due and in arrears as specified in the Termination Notice to such Leasehold Mortgagee and which may become due during such thirty (30) day period; and

**10.4.3** Comply with due diligence and continuity, or in good faith commence to and with diligence continue to pursue compliance with all non-monetary requirements of this Agreement then in default.

**10.5** The making of a Leasehold Mortgage shall not be deemed to constitute an assignment or transfer of this Agreement or of the leasehold estate hereby created, nor shall the Leasehold Mortgagee, as such, be deemed to be an assignee or transferee of this Agreement or of the leasehold estate hereby created so as to require such Leasehold Mortgagee, as such, to assume the performance of any of the terms, covenants or conditions of this Agreement. Any Leasehold Mortgagee who takes an instrument of assignment or transfer in lieu of the foreclosure of the Leasehold Mortgagee shall be deemed to be a permitted assignee or transferee, and shall be deemed to have agreed to perform all of the terms, covenants and conditions on the part of Lessee to be performed hereunder from and after the date of such purchase and assignment, but only for so long as such purchaser or assignee is the owner of the leasehold estate. If the Leasehold Mortgagee or its designee shall become holder of the leasehold estate and if the Hangar and Improvements on the Leased Premises shall have been or become materially damaged on, before or after the date of such purchase and assignment, the Leasehold Mortgagee or its designee shall be obligated to repair, replace or reconstruct the building or other improvements.

## **ARTICLE 11: RULES AND REGULATIONS**

Lessee acknowledges that the Cities have proposed or adopted rules and regulations with respect to the occupancy and use of the Airport, and such rules and regulations may be amended, supplemented or re-enacted from time to time by the Cities provided that such rules and regulations apply generally to all similar occupants and users on the Airport. Lessee and its Unit Owners agree to observe and obey any and all such rules and regulations and all other federal, state and municipal rules, regulations and laws and to require its officers, agents, employees, subtenants, contractors, and suppliers, to observe and obey the same. In the event of a conflict between the provisions of Airport Rules and Regulations and this Agreement, the more stringent provisions shall control. This provision will include compliance with the Airport's Noise Abatement Plan as it now exists and as it may hereafter be amended or supplemented. The Cities reserve the right to deny access to the Airport and its facilities to any person, firm or corporation that fails or refuses to obey and comply with such rules, regulations or laws. Nothing in this Article 11 shall be construed to limit the rights of Lessee to file any action challenging the lawfulness of any such amendment, supplement or reenactment of any such rule or regulations, or to challenge the application of the same to Lessee.

## **ARTICLE 12: SIGNS**

Lessee shall have the right to install and maintain one or more signs on the Leased Premises identifying it and its operations, provided, however, the subject matter, type, design, number, location and elevation of such signs, and whether lighted or unlighted, shall be subject to and in accordance with the City of Loveland Sign Code, and Airport Land Use and Design Standards. No sign will be allowed that may be confusing to aircraft pilots or automobile drivers or other traffic.

## **ARTICLE 13: ASSIGNMENT AND SUBLEASE**

The prior written consent of the Cities shall be required for any sale, transfer, assignment or sublease of this Agreement and of the leasehold estate hereby created. Consent may be withheld by the Cities in the event (a) Lessee is in default of any of the terms or conditions of this Agreement, (b) the transferee or assignee does not deliver to the Cities its written agreement to be bound by all of the provisions of this Agreement in a form satisfactory to the Cities, or (c) the transferee or assignee does not submit proof of insurance as required in Articles 8 and 9 herein, or (d) the transferee or assignee does not qualify as a successor to Lessee under the Condominium Declaration recorded pursuant to Article 31. Consent shall not otherwise be unreasonably withheld. Upon the granting of written consent by the Cities and actual transfer or assignment, Lessee shall be released by the Cities from its obligations under this Agreement. Other than in the manner set forth in Article 31 below, Lessee shall not subdivide or fractionalize either its ownership of the Improvements or leasehold interest in the Leased Premises.

**13.2** Lessee shall have the right and obligation to construct and sell hangar condominiums on the Leased Premises in accordance with applicable law, without the prior consent of the Cities. By way of clarification, and not by limitation, the restrictions on sale, assignment or subleasing contained in this Article 13 shall not apply to the first transfer or conveyance by Lessee of an individual Condominium Unit to another Owner. The Condominium Declaration to be recorded by Lessee shall, among other terms, conditions and restriction, require all Unit Owners to comply with all terms and conditions of this Agreement. Lessee, the Condominium Association and any Unit Owner shall be jointly and severally responsible for compliance with the terms and conditions of this Agreement; provided, that, notwithstanding the foregoing, or any other provision of this Agreement to the contrary (including by way of example and not in limitation, the provisions of Articles 9, 18 and 21), the person first above identified as Lessee ("Initial Lessee") shall not be responsible for noncompliance of any Unit Owner other than Initial Lessee or for compliance obligations of the Condominium Association, and Initial Lessee's obligations under this Agreement shall terminate at such time that Initial Lessee (i) assigns this Agreement to the Condominium Association, or (ii) holds no ownership interest in any Condominium Unit, whichever event first occurs ("Initial Lessee Termination") and all obligations of Lessee under this Agreement shall thereupon be the responsibility of the Condominium Association and the Unit Owners, as applicable in the

context of this Agreement. Following Initial Lessee Termination, except as the context otherwise indicates, the Condominium Association shall exercise the rights and fulfill the responsibilities of Lessee hereunder as Lessee and as agent and attorney-in-fact of the Unit Owners. Upon the lease of any Condominium Unit, the Unit Owner shall provide Cities with notification of the lease and otherwise comply with Article 4, above. Upon the sale, resale or lease of any Condominium Unit, Initial Lessee if the one conveying or leasing, and if not then the Condominium Association, shall promptly provide the Cities with the name, address and other contact information for the Unit Owner, and a description of the aircraft to be regularly stored in such hangar.

**13.3** Lessee shall not have the right to subdivide or fractionalize either its ownership of the Improvements or its interest in the Leased Premises, except in accordance with the Condominium Map recorded pursuant to the Act, previously approved by the Cities, and filed with a Condominium Declaration recorded pursuant to the Act and Article 31.

#### **ARTICLE 14: CONDEMNATION**

**14.1** In the event that all or any portion of the Leased Premises is taken for any public or quasi-public purpose by any lawful power or authority by the exercise of the right of appropriation, condemnation or eminent domain (or pursuant to a sale to such power or authority under the threat of condemnation or eminent domain), all rents payable with respect to that portion of the Leased Premises taken shall no longer be payable, and the proceeds, if any, from such taking or sale shall be allocated between the Cities, Lessee, and any affected Unit Owners in accordance with the applicable condemnation law, with Lessee and any affected Unit Owner being entitled to compensation for the fair market value of the leasehold interest, Improvements and personal property taken. If a portion of the Leased Premises is so taken or sold, and as a result thereof, the remaining part cannot reasonably be used to continue the authorized uses set forth in Article 3, then this Agreement shall terminate at Lessee's election, and Lessee's obligation to pay rent and perform the other conditions of the lease shall be deemed to have ceased as of the date of such taking or sale.

**14.2** The Cities expressly reserve the right to grant or take easements on rights-of-way across the Leased Premises if it is determined to be in the best interest of the Cities to do so. If the Cities grant or take an easement or right-of-way across any of the Leased Premises, Lessee shall be entitled only to compensation for damages to all Improvements owned by Lessee or its Unit Owners destroyed or physically damaged thereby, but not to damages for loss of use of the Leased Premises itself. Damages to improvements shall be determined by the reduction in fair market value of the Improvements caused by said damage or cost of repair, whichever is less.

**14.3** Lessee understands and agrees that the Cities have the right to take all or any portion of the Leased Premises, and any additions, alterations or improvements thereon, should the Cities, in their sole discretion, determine that said portion of the Leased Premises, and improvements thereon, are required for other Airport purposes, without initiating condemnation proceedings. If such action is taken, the Cities shall substitute comparable areas within the Airport, or any additions or extensions thereof, brought to the same level of improvement as the area taken. The Cities shall bear all expenses of bringing the substituted area to the same level of improvement to the area taken, and of moving Lessee's improvements, equipment, furniture and fixtures to the substituted area. If any of Lessee's improvements, equipment, furniture or fixtures cannot be relocated, the Cities shall replace, at their own expense, such non-relocatable improvements and other property with comparable property in the substituted area, and the Cities shall be deemed the owner of the non-relocated improvements and other property, free and clear of all claims of any interest or title therein by Lessee, any mortgagee, or any other third party whomsoever. It is the specific intent of this subparagraph that Lessee would be placed, to the extent possible, in the same position it would have been, had the Cities not substituted new premises for the Leased Premises; provided however, that the Cities shall not be obligated to reimburse Lessee for lost revenues or other costs due to such substitution. In the event that such substitution of area is demanded by the Cities, Lessee shall have the right and option to terminate this Agreement, prior to the Cities commencing the substitution, upon thirty (30) days prior

written notice to Cities, in which event the Cities shall pay Lessee the fair market value of all Improvements constructed on the Leased Premises pursuant to approval of the Cities. Nothing in this subparagraph shall be construed to limit the Cities' rights to condemn Lessee's leasehold rights and interests in the Leased Premises pursuant to state law.

#### **ARTICLE 15: NON-DISCRIMINATION**

**15.1** Lessee, for itself, its Unit Owners, successors in interest, and assigns, as a part of the consideration hereof, does hereby covenant and agree as a covenant running with the land that in the event facilities are constructed, maintained, or otherwise operated on the Leased Premises, for a purpose for which a United States government program or activity is extended, Lessee shall maintain and operate such facilities and services in compliance with all other requirements imposed pursuant to Title 49, Code of Federal Regulations, Department of Transportation, Subtitle A, Office of the Secretary, Part 21, Nondiscrimination in federally-assisted programs of the Department of Transportation-Effectuation of Title VI of the Civil Rights Act of 1964, and as said regulations may be amended.

**15.2** Lessee, for itself, its Unit Owners and assigns, as a part of the consideration hereof, does hereby covenant and agree as a covenant running with the land that:

**15.2.1** No person on the grounds of race, color, national origin, creed, religion, sex, disability, or age and without regard to the exercise of rights guaranteed by state or federal law shall be excluded from participating in, denied the benefits of, or be otherwise subjected to discrimination in the use of the Leased Premises;

**15.2.2** That in the construction of any Improvements on, over or under such land and the furnishing of services thereon, no person on the grounds of race, color, national origin, creed, religion, sex, disability or age shall be excluded from participation in, denied the benefits of, or otherwise be subjected to discrimination;

**15.2.3** That Lessee shall use the Leased Premises in compliance with all other requirements imposed by or pursuant to Title 49, Code of Federal Regulations, Department of Transportation, Subtitle A, Office of the Secretary, Part 21, Nondiscrimination in federally-assisted programs of the Department of Transportation Effectuation of Title VI of the Civil Rights Act of 1964, and as said regulations may be amended.

**15.3** In this connection, the Cities reserve the right to take whatever action they might be entitled by law to take in order to enforce this provision following the sixty (60) days prior written notice to Lessee, the Condominium Association and/or Unit Owner, as the case may be, of any alleged violation. This provision is to be considered as a covenant on the part of Lessee, a breach of which, continuing after notice by the Cities to cease and desist and after a determination that a violation exists made in accordance with the procedures and appeals provided by law, will constitute a material breach of this Agreement and will entitle the Cities, at their option, to exercise its right of termination as provided for herein, or take any action that it deems necessary to enforce.

**15.4** Lessee shall include the foregoing provisions in every agreement or concession pursuant to which any person or persons, other than Lessee, operates any facility at the Leased Premises providing service to the public and shall include a provision granting the Cities a right to take such action as the United States may direct to enforce such covenant.

**15.5** To the extent legally required and applicable, Lessee assures that it will undertake an affirmative action program as required by 14 CFR, Part 152, Subpart E, to ensure that no person shall on the grounds of race, creed, color, national origin, disability or sex, be excluded from participation in any employment activities covered in 14 CFR Part 152 Subpart E. Lessee assures that no person shall be excluded on these grounds from participating in or receiving the services or benefits of any program or



activity covered by this subpart. Lessee assures that it will require that its covered sub organizations provide assurances to Lessee that they similarly will undertake affirmative action program and that they will require assurances from their sub organizations, to the extent required by 14 CFR Part 152, Subpart E, to the same effect.

#### **ARTICLE 16: GOVERNMENTAL REQUIREMENTS**

**16.1** Lessee and its Unit Owners shall procure all licenses, certificates, permits or other authorization from all governmental authorities, if any, having jurisdiction over Lessee's operations at the Leased Premises which may be necessary for Lessee's and/or Unit Owner's operations on the Airport.

**16.2** Lessee shall pay all taxes, license, certification, permits and examination fees and excise taxes which may be assessed, levied, exacted or imposed on the Leased Premises or operation hereunder or on the gross receipts or gross income to Lessee there from, and shall make all applications, reports and returns required in connection therewith.

**16.3** Lessee shall pay all water, sewer, utility and other applicable use taxes and fees, arising from its occupancy and use of the Leased Premises and/or the Improvements.

#### **ARTICLE 17: RIGHTS OF ENTRY RESERVED**

**17.1** The Cities, by their officers, employees, agents, representatives and contractors, shall have the right at all reasonable times to enter upon the Leased Premises and enter the Improvements for any and all purposes not inconsistent with this Agreement, including, without limitation, inspection and environmental testing, provided such action by the Cities, their officers, employees, agents, representatives and contractors does not unreasonably interfere with Lessee's and/or Unit Owner's use, occupancy or security requirements of the Leased Premises. Except when necessary for reasons of public safety or law enforcement, or for the protection of property, as determined by Cities, Cities shall provide seventy-two (72) hours written notice of its intent to inspect.

**17.2** Without limiting the generality of the foregoing, the Cities, by their officers, employees, agents, representatives, contractors and furnishers of utilities and other services, shall have the right, at their own cost and expense, whether for their own benefit, or for the benefit of others than Lessee at the Airport, to maintain existing and future Airport mechanical, electrical and other utility systems and to enter upon the easements in the Leased Premises to make such repairs, replacements or alterations thereto, as may, in the opinion of the Cities, be deemed necessary or advisable, and from time to time to construct or install over, in or under existing easements within the Leased Premises such systems or parts thereof and in connection with such maintenance use the Leased Premises existing easements for access to other parts of the Airport otherwise not conveniently accessible; provided, however, that in the exercise of such rights of access, repair, alteration or new construction, the Cities shall not install a utility under or through any building on the Leased Premises or unreasonably interfere with the actual use and occupancy of the Leased Premises by Lessee, all such utilities to be placed within existing easements, except as provided in Article 14. It is specifically understood and agreed that the reservation of the aforesaid right by the Cities shall not impose or be construed to impose upon the Cities any obligation to repair, replace or alter any utility service lines now or hereafter located on the Leased Premises for the purpose of providing utility services only to the Leased Premises; provided, however, that if they repair, replace or alter any utility service lines now or hereafter located on the Leased Premises for the purpose of providing utility services to others, the Cities will restore the Leased Premises to their preexisting condition in a timely manner. Lessee will provide for the installation, maintenance and repair, at its own expense, of all service lines of utilities providing services only to the Leased Premises. Cities will repair, replace and maintain all other utility lines, at Cities' expense.

**17.3** In the event that any personal property of Lessee or any Unit Owner shall obstruct the access of the Cities, their officers, employees, agents or contractors, or the utility company furnishing utility service over, along and across the existing easements to any of the existing utility, mechanical, electrical

and other systems, and thus shall interfere with the inspection, maintenance or repair of any such system pursuant to Section 17.2, Lessee shall move such property, as directed by the Cities or said utility company, upon reasonable notice by the Cities, in order that access may be had to the system or part thereof for inspection, maintenance or repair. If Lessee or any Unit Owner shall fail to so move such property after direction from the Cities or said utility company to do so, the Cities or the utility company may move it, and Lessee, on behalf of itself and its Unit Owners hereby waives any claim against the Cities for damages as a result there from, except for claims for damages arising from the Cities' negligence.

## **ARTICLE 18: TERMINATION**

**18.1** In the event of a default on the part of Lessee in the payment of rents, the Cities shall give written notice to Lessee, each Unit Owner of which it has been given notice under Section 13.2, above, and each holder of a Leasehold Mortgage, if any, of which it has been give notice under Section 10.1, of such default, and demand the cancellation of this Agreement, or the correction thereof. If, within sixty (60) days after the date the Cities give such notice, Lessee has not corrected said default and paid the delinquent amount in full, then subject to Article 10 above, the Cities may by written notice to Lessee, and each such Unit Owner and holder of a Leasehold Mortgage, terminate this Agreement.

**18.2** Subject to the provisions of Section 18.1 above, this Agreement, together with all rights and privileges granted in and to the Leased Premises, shall terminate at the option of the Cities with prompt written notice to Lessee and each such Unit Owner and holder of a Leasehold Mortgage upon the happening of any one or more of the following events:

**18.2.1** The filing by Lessee of a voluntary petition in bankruptcy, or any assignment for benefit of creditors of all or any part of Lessee's assets; or

**18.2.2** Any institution of proceedings in bankruptcy against Lessee; provided, however, that Lessee may defeat such termination if the petition is dismissed within one hundred twenty (120) days after the institution thereof; or

**18.2.3** The filing of a petition requesting a court to take jurisdiction of Lessee or its assets under the provision of any Federal reorganization act which, if it is an involuntary petition is not dismissed within one hundred twenty (120) days after its being filed; or

**18.2.4** The filing of a request for the appointment of a receiver or trustee of all, or substantially all, of Lessee's assets by a court of competent jurisdiction, which if the request if not made by Lessee is not rejected within one hundred twenty (120) days after being made, or the request for the appointment of a receiver or trustee of all, or substantially all, of Lessee's assets by a voluntary agreement with Lessee's creditors.

**18.3** Upon the default by Lessee in the performance of any covenant or condition required to be performed by Lessee and/or its Unit Owners, other than the payment of rent, and the failure of Lessee, and each such Unit Owner or holder of a Leasehold Mortgage to remedy such default for a period of sixty (60) days after mailing by the Cities of written notice to remedy the same, unless more extensive notice is otherwise provided for in this Agreement, the Cities may, by written notice of cancellation to Lessee, and each such Unit Owner and holder of a Leasehold Mortgage, terminate this Agreement and all rights and privileges granted hereby in and to the Leased Premises.

**18.4** Upon the default by Lessee, and the giving of notice of the default and cancellation by the Cities as provided for elsewhere herein, the notice of cancellation shall become final.

**18.5** Subject to the provisions of Section 18.1, upon the cancellation or termination of this Agreement for any reason, all rights of Lessee, its Unit Owners, authorized tenants and any other person in possession shall terminate, including all rights or alleged rights of creditors, trustees, assigns, and all others

similarly so situated as to the Leased Premises. Except as may be expressly provided to the contrary elsewhere herein, upon said cancellation or termination of this Agreement for any reason, the Leased Premises and all Improvements located thereon, except for Lessee's equipment, fixtures and other personal property which may be removed from said Leased Premises without damage thereto as provided elsewhere herein, shall be and become the property of the Cities, free and clear of all encumbrances and all claims of Lessee, its subtenants, creditors, trustees, assigns and all others, and the Cities shall have immediate right of possession of the Leased Premises and such Improvements. Termination of this Agreement as to any Unit Owner shall not act as a merger of this Agreement, into the Cities' ownership of the applicable Condominium Unit.

**18.6** Failure by the Cities or Lessee to take any authorized action upon default by Lessee of any of the terms, covenants or conditions required to be performed, kept and observed by Lessee shall not be construed to be, nor act as, a waiver of said default nor of any subsequent default of any of the terms, covenants and conditions contained herein to be performed, kept and observed by Lessee. Acceptance of rentals by the Cities from Lessee, or performance by the Cities under the terms hereof, for any period or periods after a default by Lessee of any of the terms, covenants and conditions herein required to be performed, kept and observed by Lessee shall not be deemed a waiver or estoppel of any right on the part of the Cities to cancel this Agreement for any subsequent failure by Lessee to so perform, keep or observe any of said terms, covenants or conditions.

**18.7** This Lease will terminate at the option of Lessee:

**18.7.1** Upon the permanent closure of the Airport, the term "permanent closure" to mean for the purposes of this Agreement, the closure of the airport for ninety (90) or more consecutive days;

**18.7.2** The loss of the ability of Lessee due to no significant fault of Lessee to fly in or out of the Airport for reasons other than inclement weather, casualty or disaster, for a period of ninety (90) consecutive days; and

**18.7.3** The default by Cities in the performance of any covenant or condition required to be performed by the Cities, and the failure of the Cities to remedy such default for a period of sixty (60) days after receipt from Lessee of written notice to remedy the same, or default in the timely payment of any money due Lessee and failure to cure such default within sixty (60) days after notice to the Cities. Notice of exercise of the option to terminate by Lessee shall be given in the manner specified in Article 23 (Notices). In the event of Termination pursuant to this subsection 18.7.3, Lessee (or its Unit Owners) shall be entitled to compensation from the Cities for the fair market value of the Improvements.

**18.8** If Lessee ceases to conduct its authorized Aeronautical Activities on the Leased Premises for a period of twelve (12) consecutive months, the Cities may terminate this Agreement by written notice to Lessee given at any time while such cessation continues, unless Lessee resumes such activities within sixty (60) days following receipt of written notice from the Cities of such intent to terminate this Agreement.

**18.9** If Lessee fails to obtain any required permit or other governmental approval for the use of the Leased Premises pursuant to Section 3.1, within eighteen (18) months of the commencement date set forth in Section 1.1, or if Lessee fails to maintain any such permits or approvals during the term of this Agreement, this Agreement shall terminate, unless cured by Lessee within sixty (60) days following receipt of written notice from the Cities specifying the nature of such failure. Upon termination of this Agreement pursuant to this Section 18.9, and upon vacating the Leased Premises, Lessee shall not be required to pay additional rents, but no refund shall be due to Lessee of payments made by Lessee pursuant to this Agreement.

**18.10** Upon termination of this Agreement prior to the expiration of the Initial Term or the Extended Term, if any, the Cities may, but are not required to, relet the Leased Premises, or any part thereof, for the whole or any part of the remainder of such Initial Term or Extended Term, or for a longer period of time. Subject to Section 21.3, any rents received by the Cities as a result of such reletting shall remain the property of the Cities and shall not be credited to or otherwise become the property of Lessee.

#### **ARTICLE 19: SURRENDER AND RIGHT OF RE-ENTRY**

**19.1** Subject to Section 8.2 above, upon the expiration, cancellation or termination of this Agreement pursuant to any terms hereof, Lessee agrees peaceably to surrender up the Leased Premises to the Cities in the condition required by Article 29, below. Upon such expiration, cancellation or termination, the Cities may re-enter and repossess the Leased Premises together with all Improvements and additions thereto, or pursue any remedy permitted by law for the enforcement of any of the provisions of this Agreement, at the Cities' election.

**19.2** In the event that Lessee remains in possession of the Leased Premises after the expiration, cancellation or termination of this Lease without written agreement with respect thereto, then Lessee shall be deemed to be occupying the Leased Premises as a tenant at-will, subject to all of the conditions, provisions and obligations of this Lease, but without any rights to extend the term of this Lease. The Cities' acceptance of rent from Lessee in such event shall not alter the status of Lessee as a tenant at will whose occupancy of the Leased Premises may be terminated by Cities at any time upon ten (10) days prior written notice.

#### **ARTICLE 20: SERVICES TO LESSEE**

**20.1** The Cities covenant and agree that during the term of this Agreement, and subject to Airport priorities then in effect, they will use reasonable efforts to (a) operate the Airport as such for the use and benefit of the public; provided, however, that the Cities may prohibit or limit any given type, kind or class of aeronautical use of the Airport if such action is necessary for the safe and/or efficient operation of the Airport or necessary to serve the civil aviation needs of the public, (b) maintain the runways and taxiways in good repair, including the removal of snow, and (c) keep in good repair hard-surfaced public roads for access to the Leased Premises and remove snow there from.

**20.1.1** Said obligations of the Cities relevant to the maintenance of public roads and taxiways shall extend to the point where in such roads, streets and taxiways reach the property line of the Leased Premises, or the Ramp area constructed by Lessee under Section 4.5.

**20.1.2** Said obligations of the Cities relevant to the snow removal from public roads and taxiways shall extend to the point where in such roads, streets and taxiways reach the property line of the Leased Premises, and shall additionally include the Ramp area constructed by Lessee under Section 4.5 subject to the snow removal limitations set forth under Article 4.5.

**20.2** Except in cases of emergency, in which case no notice shall be required, Cities will endeavor to give not less than fourteen (14) days' prior written notice to Lessee of any anticipated temporary Airport closure, for maintenance, expansion or otherwise. Notwithstanding the above, the Cities shall not be deemed to be in breach of any provision of this Article 20 in the event of a permanent closure of the Airport. Provided, however, that if such permanent closure is in connection with the construction of a new airport by the Cities, Lessee shall have the option to enter into a substitute hangar ground lease agreement with the Cities, for the use of a portion of such new airport not smaller than the Leased Premises, under financial terms which are no less favorable than those set forth herein.

**ARTICLE 21: SURVIVAL OF THE OBLIGATIONS OF LESSEE**

**21.1** In the event that the Agreement shall have been terminated due to default by Lessee in accordance with notice of termination as provided in Article 18, all of the obligations of Lessee under this Agreement shall survive such termination, re-entry, regaining or resumption of possession and shall remain in full force and effect for the full term of this Agreement, and the amount or amounts of damages or deficiency shall become due and payable to the Cities to the same extent, at the same time or times, and in the same manner as if no termination, re-entry, regaining or resumption of possession had taken place. The Cities may maintain separate actions each month to recover the damage or deficiency then due or at its option and at any time may sue to recover the full deficiency less the proper discount, for the entire unexpired term of this Agreement.

**21.2** The amount of damages for the period of time subsequent to termination (or re-entry, regaining or resumption of possession) on account of Lessee's rental obligations shall be the sum of the following:

**21.2.1** The amount of the total of all installments of rents, less the installments thereof payable prior to the effective date of termination; and

**21.2.2** An amount equal to all expenses incurred by the Cities and not reimbursed in connection with regaining possession, restoring the Leased Premises required by Article 19, above, acquiring a new lease for the Leased Premises, legal expenses (including, but not limited to, attorneys' fees) and putting the Leased Premises in order.

**21.3** There shall be credited to the account of Lessee against its survived obligations hereunder, the amount actually received from any lessee, licensee, permittee, or other occupier in connection with the use of the said Leased Premises or portion thereof during the balance of the term of use and occupancy as the same is originally stated in this Agreement, and the market value of the occupancy of such portion of the Leased Premises as the Cities may themselves during such period actually use and occupy. No such use and occupancy shall be, or be construed to be, an acceptance of a surrender of the Leased Premises, nor shall such use and occupancy constitute a waiver of any rights of the Cities. The Cities will use their best efforts to minimize damages to Lessee under this Article.

**21.4** The provisions of this Article 21 shall not be applicable to termination of this Agreement pursuant to Section 3.1.2 or Section 4.4, or if expressly provided to the contrary elsewhere in this Agreement.

**ARTICLE 22: USE SUBSEQUENT TO CANCELLATION OR TERMINATION**

The Cities shall, upon termination or cancellation, or upon re-entry, regaining or resumption of possession, have the right to repair and to make structural or other changes in the Leased Premises, including changes which alter its character and the suitability thereof for the purposes of Lessee under this Agreement, without affecting, altering or diminishing the obligations of Lessee hereunder, provided that any structural changes shall not be at Lessee's expense.

**ARTICLE 23: NOTICES**

**23.1** Any notice, consent, approval or other communication given by either party to the other relating to this Agreement shall be in writing, and shall be delivered in person, sent by U.S. mail postage prepaid, sent by reputable overnight courier, or sent by electronic means (with evidence of such transmission received) to such other party at the respective addresses set forth below (or at such other address as may be designated from time to time by written notice given in the manner provided herein). Such notice shall, if hand delivered or personally served, be effective immediately upon receipt. If sent by US mail postage prepaid, such notice shall be deemed given on the third business day following deposit in

the United States mail, postage prepaid and properly addressed; if delivered by overnight courier, notice shall be deemed effective on the first business day following deposit with such courier; and if delivered by electronic means, notice shall be deemed effective when received.

**23.2** The notice addresses of the parties are as follows:

To the Cities: Northern Colorado Regional Airport Commission  
Attn: Airport Manager  
4900 Earhart Drive  
Loveland, CO 80538  
Facsimile: (970) 962-2855  
Email address: airport@cityofloveland.org

With a copy to:

Loveland City Attorney's Office  
500 E. Third Street  
Loveland, CO 80537

and

To Lessee: IC Loveland, LLC  
Attn: Ryan McClurg  
8082 South Interport Boulevard, Ste. 200  
Englewood, CO 80112  
Email Address: ryan@mcclurg.net

**ARTICLE 24: INVALID PROVISIONS**

The invalidity of any provisions, articles, paragraphs, portions or clauses of this Agreement shall have no effect upon the validity of any other part or portion hereof, so long as the remainder shall constitute an enforceable agreement. Furthermore, in lieu of such invalid provisions, articles, paragraphs, portions or clauses, there shall be added automatically as a part of this Agreement, a provision as similar in terms to such invalid provision as may be possible and be legal, valid and enforceable.

**ARTICLE 25: MISCELLANEOUS PROVISIONS**

**25.1 Remedies to be Non-exclusive.** All remedies provided in this Agreement shall be deemed cumulative and additional and not in lieu of, or exclusive of, each other, or of any other remedy available to the Cities, or Lessee, at law or in equity, and the exercise of any remedy, or the existence herein of other remedies or indemnities shall not prevent the exercise of any other remedy provided that the Cities' remedies in the event of default shall not exceed those set forth in this Agreement.

**25.2 Non-liability of Individuals.** No director, officer, agent or employee of the Cities shall be charged personally or held contractually liable by or to the other party under any term or provision of this Agreement or of any supplement, modification or amendment to this Agreement because of any breach thereof, or because of his or their execution or attempted execution of the same. Except to the extent expressly provided for herein, no officer, director, shareholder, manager, member, agent or employee of Lessee or of any Unit Owner shall be charged personally or held contractually liable by or to the other party under any term or provision of this Agreement or of any supplement, modification or amendment to this Agreement because of any breach thereof, or because of his or their execution or attempted execution of the same.

**25.3** Estoppel Certificate. At the request of Lessee in connection with an assignment of its interest in this Agreement, the Cities shall execute and deliver a written statement identifying them as the Lessors under this Agreement and certifying:

**25.3.1** The documents that then comprise this Agreement,

**25.3.2** That this Agreement is in full force and effect,

**25.3.3** The then current annual amount of rent and the date through which it has been paid,

**25.3.4** The expiration date of this Agreement,

**25.3.5** That no amounts are then owed by Lessee to the Cities (or, if amounts are owed, specifying the same)

**25.3.6** To the knowledge of the Cities, there are not defaults by Lessee under this Agreement or any facts which but for the passage of time, the giving of notice or both would constitute such a default, and

**25.3.7** Remaining rights to renew the term of this lease to the extent not theretofore exercised.

The party acquiring Lessee's interest in the Agreement shall be entitled to rely conclusively upon such written statement.

**25.4** Recording of Lease. This Agreement shall be recorded by the Cities, and the costs of such recordation, and any closing costs associated with this Agreement, its execution and recordation, shall be billed to and paid by Lessee as additional rent.

**25.5** General Provisions.

**25.5.1** This Agreement and shall be construed in accordance with the laws of the State of Colorado, venue shall be in Larimer County, Colorado.

**25.5.2** This Agreement is made for the sole and exclusive benefit of the Cities and Lessee, their successors and assigns, and is not made for the benefit of any third party.

**25.5.3** In the event of any ambiguity in any of the terms of this Agreement, it shall not be construed for or against any party hereto on the basis that such party did or did not author the same.

**25.5.4** All covenants, stipulations and agreements in this Agreement shall extend to and bind each party hereto, its legal representatives, successors and assigns.

**25.5.5** The titles of the several articles of this Agreement are for inserted herein for convenience only, and are not intended and shall not be construed to affect in any manner the terms and provisions hereof, or the interpretation or construction thereof.

**25.5.6** Nothing herein contained shall create or be construed to create, a partnership, joint venture, agency or any other relationship between the Cities and Lessee, other than that of landlord and tenant. The Cities and Lessee each expressly disclaim the existence of any such other relationship between them.

**25.5.7** Cities have and may allow certain portions of the Airport to be used by other tenants at any time and Lessee shall not interfere in any manner with said other tenants or with the facilities granted to such tenants. Nothing herein contained shall be construed to grant or authorize

the granting of an exclusive right prohibited by Section 308 of the Federal Aviation Act of 1958, as amended, and the Cities reserve the right to grant to others the privilege and right of conducting any one or all of the activities specified herein, or any other activities of an aeronautical nature.

**25.5.8** In the event any action or proceeding is brought to recover payments due under this Agreement or take possession of the Leased Premises and/or the improvements thereon, or to enforce compliance with this Agreement for failure to observe any of its covenants, the prevailing party shall be awarded reasonable attorneys' fees and costs as set by the court.

**25.5.9** The time within which either party hereto shall be required to perform any act under this Agreement, other than the payment of money, shall be extended by a period equal to the number of days during which performance of such act is delayed unavoidably by strikes, lockouts, acts of God, governmental restrictions, failure or inability to secure materials or labor by reason of or similar regulation or order of any governmental or regulatory body, war, enemy action, acts of terrorism, civil disturbance, fire, unavoidable casualties, or any similar occurrence.

**25.6** Availability of Government Facilities. In the event the existence, maintenance or operation of air navigation aids or other facilities supplied or operated by the United States or the State of Colorado at or in conjunction with the Airport are discontinued, the Cities shall have no obligation to furnish such facilities.

**25.7** The Cities designate the Commission and the Airport Manager as its representatives who shall make, within the scope of their authority, all necessary and proper decisions with reference to the Lease.

**25.8** The parties further acknowledge and agree that this Lease Agreement replaces and supersedes the prior lease agreements for the Leased Premises approved by the Cities on May 17, 2017 with Loren and Heidi Johnson (originally KFNL Hangars, LLC) and CO Fire Aviation Leasing (originally KFNL Hangars, LLC).

## **ARTICLE 26: SUBORDINATION CLAUSES**

**26.1** This Agreement is subject and subordinate to the following:

**26.1.1** The Cities reserve the right to develop and improve the Airport as they see fit, regardless of the desires or view of Lessee, and without interference or hindrance by or on behalf of Lessee, provided Lessee is not deprived of the use or access to the Leased Premises or any of Lessee's rights under this Agreement and unless said activities by the Cities shall result in the loss of convenient access to the Leased Premises by motor vehicles and/or aircraft owned or operated by Lessee or Lessee's assigns, subtenants, renters, agents, employees or invitees.

**26.1.2** The Cities reserve the right to take any action they consider necessary to protect the aerial approaches to the Airport against obstruction, together with the right to prevent Lessee from erecting or permitting to be erected any building or other structure on the Airport which would limit the usefulness of the Airport or constitute a hazard to aircraft.

**26.1.3** This Agreement is and shall be subordinate to the provision of existing and future agreements between the Cities and the United States relative to the operation or maintenance of the Airport, the execution of which has been or may be required as a condition precedent to the obtaining or expenditure of federal funds for the benefit of the Airport.

**26.1.4** During the time of war or national emergency, the Cities shall have the right to lease all or any part of the landing area or of the airport to the United States for military use, and if any such lease is executed, the provisions of this Agreement insofar as they may be inconsistent with the provisions of such lease to the government, shall be suspended, but such suspension shall



not extend the term of this Agreement. Abatement of rentals shall be reasonably determined by the Cities and Lessee in proportion to the degree of interference with Lessee's use of the Leased Premises.

**26.1.5** Except to the extent required for the performance of any obligations of Lessee hereunder, nothing contained in this Agreement shall grant to Lessee any rights whatsoever in the airspace above the Leased Premises other than those reasonably necessary to Lessee's enjoyment of the Leased Premises and Cities' Airport facilities and which are consistent with Federal Aviation Administration rules, regulations and orders currently or subsequently effective. Further, Lessee's rights in airspace above the Leased Premises and the Airport and the Airport facilities shall be not less than the rights therein by other users of the Airport and Airport facilities.

#### **ARTICLE 27: QUIET ENJOYMENT**

Cities hereby covenant and warrant that they are the owners of the Leased Premises and that Lessee upon payment of rentals herein provided for and performance of provisions on its part to be performed shall and may peacefully possess and enjoy the Leased Premises during the term hereof and any extensions hereof without any interruption or disturbance.

#### **ARTICLE 28: ENTIRE AGREEMENT**

This Agreement constitutes the entire agreement of the parties hereto and may be changed, modified, discharged or extended by written instrument duly executed by the Cities and Lessee. The parties agree that no representations or warranties shall be binding upon the Cities or Lessee unless expressed in writing.

#### **ARTICLE 29: TITLE TO IMPROVEMENTS UPON TERMINATION**

**29.1** Upon the expiration, cancellation or termination of this Agreement, Lessee may elect to remove the Improvements and all additions and appurtenances thereto at its own expense in accordance with the following:

(a) Lessee may elect to remove the Improvements upon expiration of the Initial Term or any Extended Term by giving the Cities written notice of Lessee's election not less than sixty (60) days prior to the expiration of the Initial Term or Extended Term (the "Notice Deadline"). If Lessee gives such written notice of its election on or before the Notice Deadline, Lessee shall complete removal of the Improvements and all additions and appurtenances as required by this Article 29 on or before the expiration of the Initial Term or any Extended Term. Failure of Lessee to give such written notice of its election on or before the Notice Deadline shall be deemed to be an election, by Lessee, to surrender ownership of the Improvements and all additions and appurtenances thereto to the Cities in accordance with Section 29.2 below.

(b) Lessee may elect to remove the Improvements upon cancellation or termination of this Agreement by giving the Cities written notice of its election within thirty (30) days after such cancellation or termination. Provided Lessee is not in default in the payment of rental or other financial obligations due hereunder and has given written notice of its election within such thirty (30) day period, Lessee shall have a reasonable time, not to exceed sixty (60) days after notice of such election is given to the Cities, in which to complete removal of Improvements and restoration as required by this Article 29. During any occupancy by Lessee after cancellation or termination of this Agreement for the time period prior to completion of removal of Improvements and restoration, Lessee shall be deemed to be holding over under the terms and conditions of Section 19.2 above and shall pay to the Cities rent at the then-current lease rate for such period. If Lessee (i) fails to give such written notice of its election within the thirty (30) day period set forth in this subsection (b); or (ii) is ineligible to make such election because Lessee is in default in the

payment of rental or other financial obligations due hereunder, Lessee shall be deemed to have made an election to surrender ownership of the Improvements and all additions and appurtenances thereto to the Cities in accordance with Section 29.2.

(c) Removal of Improvements and all additions and appurtenances thereto and restoration as required under this Article 29 shall include Lessee's completion of all work necessary to leave the Leased Premises in a clean, orderly, and as close to original condition as possible as approved by the Cities, and shall include as a minimum:

(i) removal of all Improvements and above ground structures and above ground foundations, including utilities and utility connections, which shall be capped or otherwise left in a safe condition; and

(ii) modification of the surface so that it is free of any holes or obstructions that would prevent normal aircraft taxi operations and graded as necessary to ensure proper drainage.

**29.2** In the event that Lessee fails to give written notice to the Cities of its election to remove Improvements within the time periods and as otherwise provided in Section 29.1 above, then Cities and Lessee agree that in consideration of Lessee's use of the Airport for construction and operation of the Improvements, the Improvements and all additions and appurtenances thereto shall become the property of and title shall automatically vest in the Cities upon expiration, cancellation or termination of this Agreement, without payment of additional consideration by the City, and free and clear of all liens and encumbrances. Lessee agrees to execute all documents and take such reasonable actions, if any, as may be necessary to confirm the transfer of title to the Improvements to the Cities.

Lessee's obligations under this Article 29 shall survive any expiration, cancellation, or termination of this Agreement

### **ARTICLE 30: RIGHT OF FIRST REFUSAL**

If at any time Lessee desires to sell, assign, or otherwise transfer its interest under this Agreement, including the Improvements existing on the Leased Premises, or if any Unit Owner desires to sell its interest in any Unit, to an Unaffiliated Entity as defined in Section 10.1 and has obtained a bona fide offer for such sale, Lessee and/or such Unit Owner must first offer to sell, assign, or otherwise transfer such interest to the Cities, at the price and on the same terms as such bona fide offer, and the Cities shall have the right to purchase Lessee's and /or such Unit Owner's interest under such terms. Such offer must be in writing and state the name of the proposed transferee and all of the terms and conditions of the proposed transfer. The Cities shall have the right for a period of sixty (60) days after receipt of the offer from Lessee or Unit Owner to elect to purchase Lessee's and/or Unit Owner's interest (such sixty (60) day period referred to as the "Election Period"). If the Cities do not desire to purchase Lessee's and/or Unit Owner's interest, Lessee and/or unit Owner may then sell, assign, or otherwise transfer its interest in this Agreement or the Unit to the person making the said offer, at the price and terms set forth in the offer, subject to the requirements of Article 13. If Lessee and/or Unit Owner fail to close such sale within sixty (60) days after the expiration of the Election Period, any proposed sale, assignment or other transfer thereafter shall again be subject to this Article. This right of the Cities shall be continuing and shall survive any sale, assignment or other transfer of Lessee's interest under this Agreement. The intent of this Article is to require all of Lessee's interests in this Agreement be sold, assigned or otherwise transferred intact, without fractionalization; except as contemplated by subletting the Lease Premises to the Condominium Declarant pursuant to Article 31. The foregoing right of first refusal shall not apply to the first sale, assignment or other transfer of an interest of any individual Hangar Condominium Unit by Lessee to the first Owner of such Unit.

**ARTICLE 31: REQUIREMENTS FOR CONDOMINIUMIZATION**

**31.1** Prior to the sale of any Hangar Condominium Unit on the Leased Premises, Lessee shall cause a declaration to be recorded in the real property records of Larimer County, Colorado, in compliance with the Condominium Ownership Act (the "Act"), C.R.S. §38-33-105. Lessee shall not record such declaration unless it first provides the Cities' with a copy of such declaration and establishes to the reasonable satisfaction of the Cities that the declaration contains each provision required by this Agreement. The Cities shall not sign such a declaration or otherwise subject this Agreement to the provisions of C.R.S. §38-33.3-206(1).

**31.2** At all times during the term of this Agreement, the Condominium Declaration recorded by Lessee pursuant to the Act shall provide the recording data for this Agreement; the date on which this Agreement is scheduled to expire; a legal description of the Leased Premises; a statement that the Unit Owners have no right to redeem any reversion in the Leased Premises or this Agreement; a statement that Unit Owners have no right to remove any Improvements on the Leased Premises, including at or after termination of this Agreement; and a statement that Unit Owners have no right to renew this Agreement at or after termination, other than the contingent right of Lessee to do so under Article 1.3, above.

**31.3** The Condominium Declaration recorded by Lessee hereunder shall require that with respect to Units and the Unit Owner's use thereof, and activities of Unit Owners on the Airport, each Unit Owner shall comply with applicable terms of this Agreement, and shall take no action which is in violation of any term or condition of this Agreement. The Condominium Declaration shall provide that any act or omission of a Unit Owner which is contrary to or violates the terms of this Agreement, or of any Airport rule or regulation, shall be a violation of the terms of the Condominium Declaration, and shall contain adequate provisions for Lessee's enforcement of such requirements. Before or at the closing of any sale or resale of a Condominium Unit, the purchaser of the Condominium Unit shall be required to sign and deliver to the Cities, on a form acceptable to the Cities, a declaration providing purchaser's name, address and contact information, and acknowledging that such purchaser has been provided with a copy of this Agreement and the Condominium Declaration, has read this Section 31.3, and understands purchaser's obligations to comply with the applicable terms of this Agreement.

**31.4** The Condominium Declaration required by Lessee hereunder shall require the formation of a Condominium Association (being a Colorado non-profit corporation) which, subject to the terms of this Agreement, will have broad authority over and govern the use and operation of the Leased Premises and the Hangar Units, and grant to the Condominium Association the right to enforce all of the terms, conditions and covenants of this Agreement against the Unit Owner, to assess the Unit Owners for the purpose of funding the payment of all monetary amounts due and payable pursuant to the terms of this Agreement and to serve as agent for the Unit Owners in dealing with the Cities pursuant to this Agreement.

**IN WITNESS WHEREOF**, the parties hereto have executed this Agreement on the day and year first above written.

**LESSOR:**

NORTHERN COLORADO REGIONAL AIRPORT COMMISSION  
ON BEHALF OF THE CITIES OF FORT COLLINS AND LOVELAND

  
\_\_\_\_\_  
Don Overcash, Chair  
Northern Colorado Regional Airport Commission

8-27-2021  
Date

**ATTEST:**

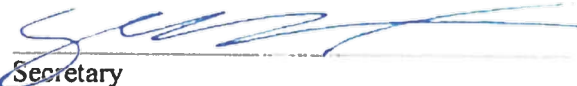
  
\_\_\_\_\_  
Secretary

**APPROVED AS TO FORM:**

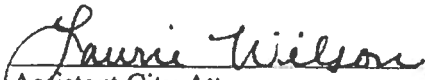
  
\_\_\_\_\_  
Assistant City Attorney  
for Northern Colorado Regional Airport Commission

**LESSEE:**

IC Loveland, LLC

  
\_\_\_\_\_  
Ryan McClurg

9/9/22  
Date

**Exhibit A**

**PROPERTY DESCRIPTION**

A parcel of land being part of Tract B, Barnstorm Second Addition, recorded August 12, 1986 as Reception No. 86044345 of the Records of Larimer County, located in the Northeast Quarter (NE1/4) of Section Thirty-three (33), Township Six North (T.6N.), Range Sixty-eight West (R.68W.) of the Sixth Principal Meridian (6th P.M.), City of Loveland, County of Larimer, State of Colorado and being more particularly described as follows:

**COMMENCING** at the Northeast corner of said Section 33 and assuming the East line of said NE1/4 as bearing South 00°24'38" East being a Grid Bearing of the Colorado State Plane Coordinate System, North Zone, North American Datum 1983/2011, a distance of 2599.42 feet with all other bearings contained herein relative thereto;

THENCE South 00°24'38" East along the East line of said NE1/4 a distance of 1791.63 feet;  
THENCE South 89°35'22" West a distance of 144.78 feet to the **POINT OF BEGINNING**;

THENCE South 19°09'39" East a distance of 51.42 feet;  
THENCE South 70°50'04" West a distance of 15.00 feet;  
THENCE South 19°09'35" East a distance of 145.59 feet;  
THENCE South 70°51'01" West a distance of 816.80 feet;  
THENCE North 19°08'59" West a distance of 192.11 feet;  
THENCE North 70°30'47" East a distance of 831.78 feet to the **POINT OF BEGINNING**.

Said described parcel of land contains 159,648 Square Feet or 3.665 Acres, more or less (±), and is subject to any rights-of-way or other easements of record or as now existing on said described parcel of land.

**SURVEYORS STATEMENT**

I, Christopher A. DePaulis, a Colorado Licensed Professional Land Surveyor do hereby state that this Parcel Description was prepared under my personal supervision and checking and that it is true and correct to the best of my knowledge and belief.

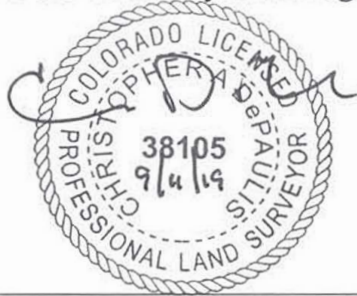

---

Christopher A. DePaulis- On Behalf Of King Surveyors  
Colorado Licensed Professional  
Land Surveyor #38105

**KING SURVEYORS**  
650 East Garden Drive  
Windsor, Colorado 80550  
(970) 686-5011

LINE TABLE		
LINE	BEARING	LENGTH
L1	S19°09'39"E	51.42'
L2	S70°50'04"W	15.00'

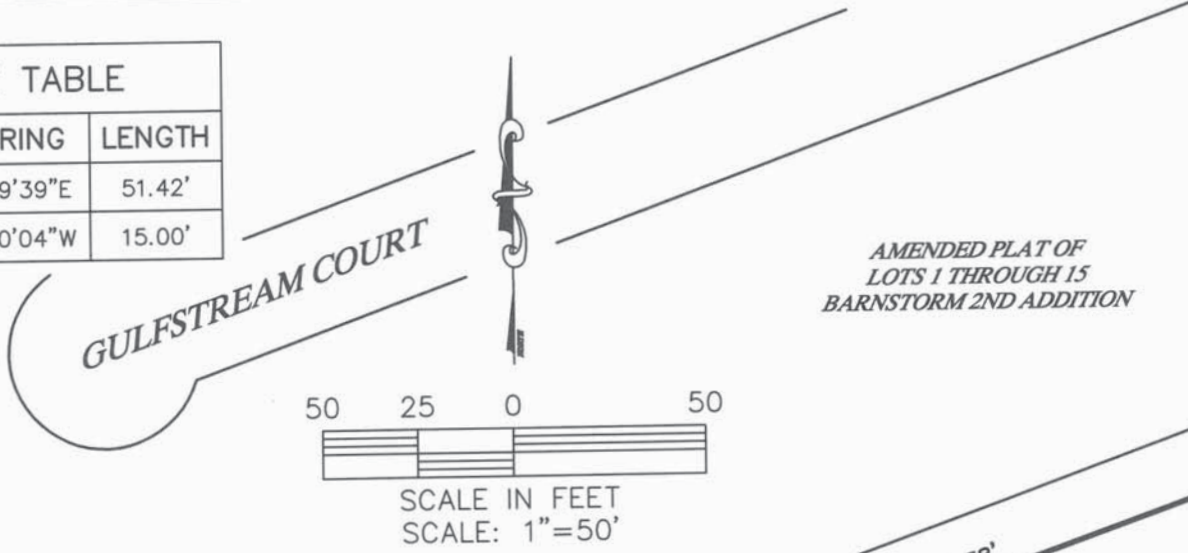

AMENDED PLAT OF  
LOTS 1 THROUGH 15  
BARNSTORM 2ND ADDITION

LEASE PARCEL  
159,648 SQ.FT.  
3.665 ACRES

NORTHEAST CORNER  
SECTION 33, T.6N., R.68W.  
FOUND 2" PIPE WITH  
3" BRASS CAP LS 13446  
POINT OF COMMENCEMENT

POINT OF BEGINNING

S89°35'22"W  
144.78'

1791.63'

2599.42'

807.79'  
(BASIS OF BEARINGS)

145.59'

S19°09'35"E

L1

L2

EXISTING BUILDING

N19°08'59"W 192.11'

S70°51'01"W 816.80'

EAST QUARTER CORNER  
SECTION 33, T.6N., R.68W.  
FOUND #6 REBAR WITH  
2" ALUMINUM CAP LS 11989

TRACT B  
BARNSTORM  
2ND ADDITION

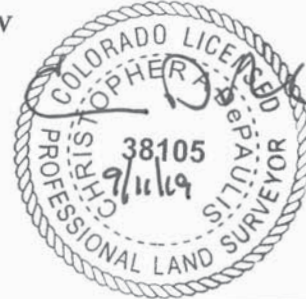

Christopher A. DePaulis - On Behalf Of King Surveyors  
Colorado Licensed Professional  
Land Surveyor #38105

NOTE: This exhibit drawing is not intended to be a monumented land survey. Its sole purpose is as a graphic representation to aid in the visualization of the written property description which it accompanies. The written property description supersedes the exhibit drawing.

NOTICE: According to Colorado law you must commence any legal action based upon any defect in this survey within three years after you first discover such defect. In no event may any action based upon any defect in this survey be commenced more than ten years from the date of the certification shown hereon. (13-80-105 C.R.S. 2012)

PROJECT NO: 20190175-B  
DATE: 9/11/2019  
CLIENT: N. CO REGIONAL AIRPORT  
DWG: 20190175B-EXH  
DRAWN: CSK CHECKED: CAD

**KING SURVEYORS**  
650 E. Garden Drive | Windsor, Colorado 80550  
phone: (970) 686-5011 | fax: (970) 686-5821  
email: contact@KingSurveyors.com



# Exhibit B

HANGAR MIX						
Hangar Type	Hangar Size	Door Size	COUNT	UNIT AREA	TOTAL UNIT AREA	% MIX
(A)RG62-65	62' X 65'	64'-6" x 18'	6	4030 SF	24180 SF	26.1%
(B)RG52-56	52' X 56'	55'-6" x 16'	12	2912 SF	34944 SF	52.2%
(C)RG62-42 (Custom)	62' X 42'	41'-6" x 12'	3	2604 SF	7812 SF	13.0%
(D)RG62-80	62' X 80'	64'-6" x 18'	2	4960 SF	9920 SF	8.7%
Grand total:			23		76856 SF	

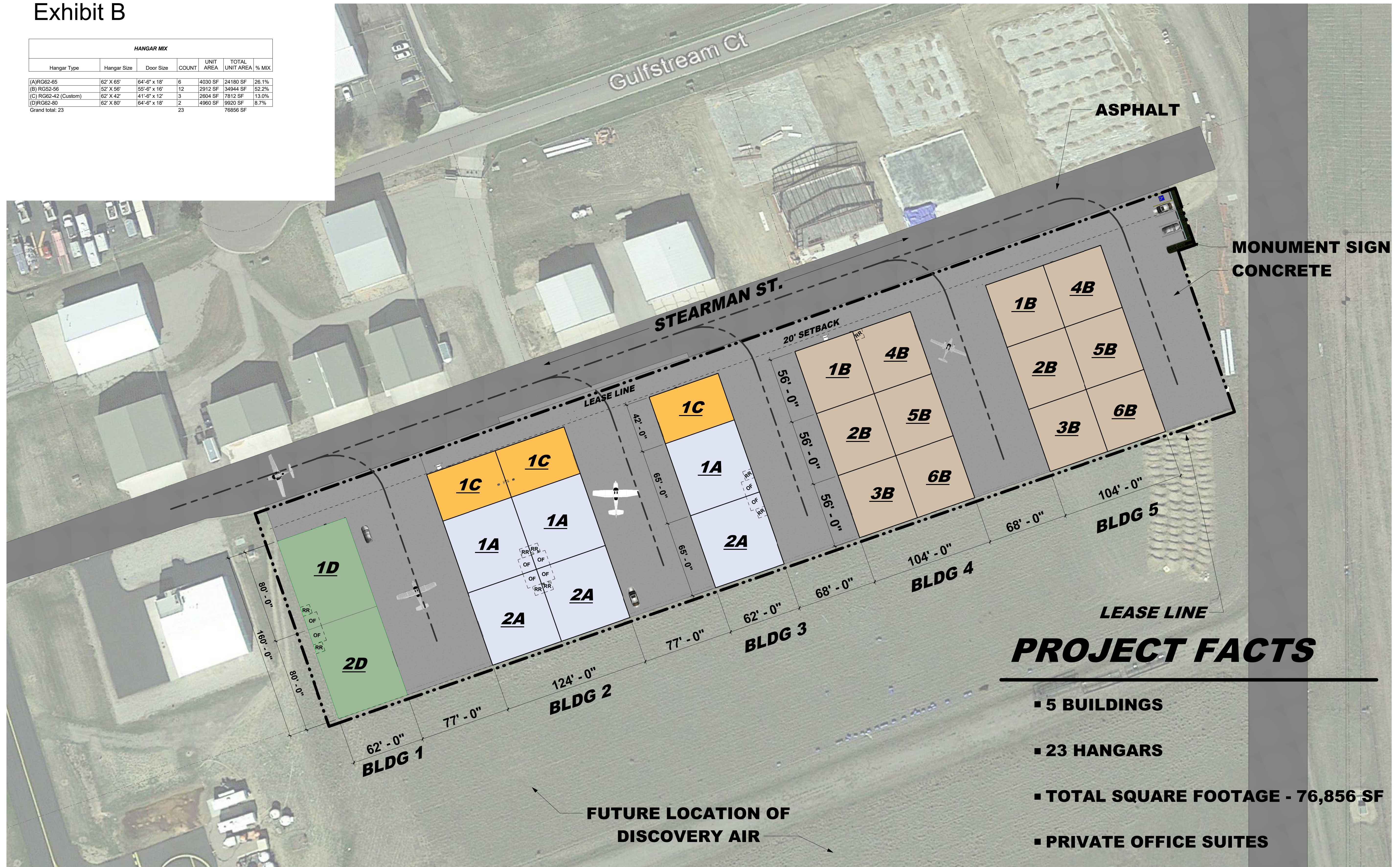

## PROJECT FACTS

- 5 BUILDINGS
- 23 HANGARS
- TOTAL SQUARE FOOTAGE - 76,856 SF
- PRIVATE OFFICE SUITES

**1 GRAPHIC SITE PLAN**  
1" = 40'-0"

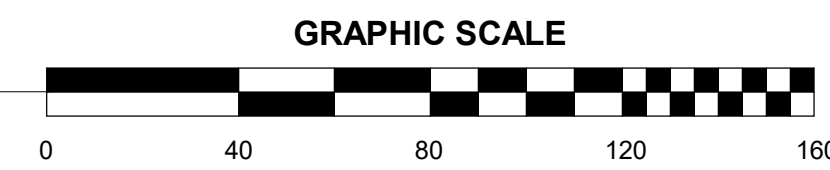

<b>Payment Date</b>	<b>Payment</b>	<b>Principal</b>	<b>Interest</b>	<b>Total Interest</b>	<b>Balance</b>
Sep 2022	\$4,321.17	\$3,801.84	\$519.33	\$519.33	\$109,505.67
Oct 2022	\$4,321.17	\$3,819.27	\$501.90	\$1,021.23	\$105,686.40
Nov 2022	\$4,321.17	\$3,836.77	\$484.40	\$1,505.62	\$101,849.63
Dec 2022	\$4,321.17	\$3,854.36	\$466.81	\$1,972.43	\$97,995.28
Jan 2023	\$4,321.17	\$3,872.02	\$449.15	\$2,421.58	\$94,123.26
Feb 2023	\$4,321.17	\$3,889.77	\$431.40	\$2,852.98	\$90,233.49
Mar 2023	\$4,321.17	\$3,907.60	\$413.57	\$3,266.55	\$86,325.89
Apr 2023	\$4,321.17	\$3,925.51	\$395.66	\$3,662.21	\$82,400.39
May 2023	\$4,321.17	\$3,943.50	\$377.67	\$4,039.88	\$78,456.89
Jun 2023	\$4,321.17	\$3,961.57	\$359.59	\$4,399.47	\$74,495.32
Jul 2023	\$4,321.17	\$3,979.73	\$341.44	\$4,740.91	\$70,515.59
Aug 2023	\$4,321.17	\$3,997.97	\$323.20	\$5,064.10	\$66,517.62
Sep 2023	\$4,321.17	\$4,016.29	\$304.87	\$5,368.98	\$62,501.33
Oct 2023	\$4,321.17	\$4,034.70	\$286.46	\$5,655.44	\$58,466.62
Nov 2023	\$4,321.17	\$4,053.19	\$267.97	\$5,923.41	\$54,413.43
Dec 2023	\$4,321.17	\$4,071.77	\$249.39	\$6,172.81	\$50,341.66
Jan 2024	\$4,321.17	\$4,090.43	\$230.73	\$6,403.54	\$46,251.23
Feb 2024	\$4,321.17	\$4,109.18	\$211.98	\$6,615.52	\$42,142.04
Mar 2024	\$4,321.17	\$4,128.02	\$193.15	\$6,808.68	\$38,014.03
Apr 2024	\$4,321.17	\$4,146.94	\$174.23	\$6,982.91	\$33,867.09
May 2024	\$4,321.17	\$4,165.94	\$155.22	\$7,138.13	\$29,701.15
Jun 2024	\$4,321.17	\$4,185.04	\$136.13	\$7,274.26	\$25,516.12
Jul 2024	\$4,321.17	\$4,204.22	\$116.95	\$7,391.21	\$21,311.90
Aug 2024	\$4,321.17	\$4,223.49	\$97.68	\$7,488.89	\$17,088.41
Sep 2024	\$4,321.17	\$4,242.84	\$78.32	\$7,567.21	\$12,845.57
Oct 2024	\$4,321.17	\$4,262.29	\$58.88	\$7,626.09	\$8,583.28
Nov 2024	\$4,321.17	\$4,281.83	\$39.34	\$7,665.43	\$4,301.45
Dec 2024	\$4,321.17	\$4,301.45	\$19.71	\$7,685.14	\$0.00