

Folsom City Council Staff Report

MEETING DATE:	2/27/2024
AGENDA SECTION:	Consent Calendar
SUBJECT:	Resolution No. 11174 - A Resolution Authorizing the City Manager to Execute a Construction Agreement with MCM Roofing Company, Inc. for the Emergency Replacement of 79 Skylights at the Andy Morin Sports Complex and Appropriation of Contingency Funds
FROM:	Parks and Recreation Department

RECOMMENDATION / CITY COUNCIL ACTION

The Parks and Recreation Department recommends the City Council pass and adopt Resolution No. 11174 – A Resolution Authorizing the City Manager to Execute a Construction Agreement with MCM Roofing Company, Inc. for the Emergency Replacement of 79 Skylights at the Andy Morin Sports Complex and Appropriation of Contingency Funds.

BACKGROUND / ISSUE

During recent heavy storms, several skylights at the Andy Morin Sports Complex were damaged by high winds, and/or wind-driven debris. The damage to the skylights created heavy flooding in the interior space of the Sports Complex, particularly in the area where the hardwood basketball courts and pitching machines are located. Due to the age and condition of the existing skylights, the recommendation of our roofing contractor is to replace all 79 skylights.

POLICY / RULE

In accordance with **Chapter 2.36.150** of the Folsom Municipal Code, Notwithstanding any other provisions of this chapter, the city manager shall make, or authorize others to make, emergency procurement of supplies, equipment, services, or construction items when there exists a threat to public health, welfare, or safety; provided, that such emergency procurement shall be made with sufficient competition as is practicable under the circumstances. The requesting department shall complete a waiver of bid format and submit it to the purchasing agent for filing with the city clerk. (Ord. 723 § 3 (part), 1991)

ANALYSIS

Even though the Facilities Services Division and our roofing vendor have made temporary repairs, there is still the potential for further water intrusion into the interior spaces of the Sports Complex, particularly during periods of heavy rain/wind. To address these issues in the timeliest manner, staff is recommending the City engage in a contract with MCM Roofing Inc. for the amount of \$104,500. The staff is also requesting a 15% contingency of \$15,675 for unforeseen conditions.

FINANCIAL IMPACT

The request for a 15% construction contingency exceeds the 10% construction contingency authorized in the Folsom Municipal Code but is highly recommended due to conditions that are not known at this time. The total project with contingency would be in the amount of \$120,175.

Project Costs:

Total Contract	\$104,500
Construction Contingency	\$ 15,675
<hr/>	
Total project Cost	\$120,175

The cost of replacing the Folsom Sports Complex skylights will be financed from the General Fund's (Fund 010) contingency budget. Sufficient funds for this emergency procurement are available in the General Fund's (Fund 010) contingency budget.

ENVIRONMENTAL REVIEW

In accordance with the California Environmental Quality Act, (CEQA) the proposed project is Categorically Exempt per Article 19, 15300.1 – Relation to Ministerial Projects.

ATTACHMENTS

1. Resolution No. 11174 - A Resolution Authorizing the City Manager to Execute a Construction Agreement with MCM Roofing Company, Inc. for the Emergency Replacement of 79 Skylights at the Andy Morin Sports Complex and Appropriation of Contingency Funds
2. Proposal for MCM Roofing Inc. to remove and replace 59 skylights at the Folsom Sports Complex
3. Proposal for MCM Roofing Inc. to remove and replace 20 skylights at the Folsom Sports Complex

Submitted,

Kelly Gonzalez, Director
Parks & Recreation Department

ATTACHMENT 1

Resolution No. 11174 - A Resolution Authorizing the City Manager to Execute a Construction Agreement with MCM Roofing Company, Inc. for the Emergency Replacement of 79 Skylights at the Andy Morin Sports Complex and Appropriation of Contingency Funds

RESOLUTION NO. 11174

A RESOLUTION AUTHORIZING THE CITY MANAGER TO EXECUTE A CONSTRUCTION AGREEMENT WITH MCM ROOFING COMPANY, INC. FOR THE EMERGENCY REPLACEMENT OF 79 SKYLIGHTS AT THE ANDY MORIN SPORTS COMPLEX AND APPROPRIATION OF CONTINGENCY FUNDS

WHEREAS, the Andy Morin Sports Complex has had multiple failures of the existing skylights during recent storms causing major water intrusion into the interior space; and

WHEREAS, the existing skylights have reached the end of their useful life, and cannot be repaired, and the recommendation from both the Folsom Facilities Services Division and the City's roofing vendor is that all seventy-nine (79) skylights be replaced; and

WHEREAS, there will be a significant loss of revenue as well as increased damage to the interior structure of the Folsom Sports Complex if the skylights are not repaired; and

WHEREAS, sufficient funds for this emergency procurement are available in the General Fund's (Fund 010) contingency budget; and

WHEREAS, the agreement will be in a form acceptable to the City Attorney:

NOW, THEREFORE, BE IT RESOLVED that the City Council of the City of Folsom authorizes the City Manager to execute a construction agreement with MCM Roofing Company, Inc., for the amount of \$104,500, along with a contingency of 15%, \$15,675, and the Finance Director is authorized to appropriate an amount not to exceed \$120,175 from the General Fund contingency budget for the Andy Morin Sports Complex emergency skylight replacement procurement.

PASSED AND ADOPTED this 27 day of February 2024, by the following roll-call vote:

AYES: Councilmember(s):
NOES: Councilmember(s):
ABSENT: Councilmember(s):
ABSTAIN: Councilmember(s):

Michael D. Kozlowski, MAYOR

ATTEST:

Christa Freemantle, CITY CLERK

ATTACHMENT 2

Proposal for MCM Roofing Inc. to remove and replace 59 skylights at the Folsom Sports Complex



MCM Roofing Company Inc.

February 6, 2024

Mr. Shane Thompson
City of Folsom
50 Natoma Street
Folsom CA 95630

APPROVED

Chris O'Keefe

Via email: sjthompson@folsom.ca.us

Re: Proposal for Replacement of (59) Skylights at the Sports Complex

Shane,

MCM Roofing Company Inc. is pleased to quote a price of \$76,700 (Seventy-Six Thousand Seven Hundred Dollars) to remove and replace the remaining (59) skylights at the Sports Complex in Folsom as requested. Our scope of work has the following inclusions and exclusions.

Inclusions:

- Mobilization with equipment and manpower.
- Removal of the existing (59) skylights for disposal.
- Installation of (59) 48" X 96" dual pane white skylights to fit the existing roof curbs.
- Installation of new foam gaskets around the top edge of the existing curbs.
- Attachment of the skylights with new screws and neoprene washers- placed at every factory attachment hole location.
- Maintain the watertightness of the roof system while the work is performed.
- Manufacturer's standard 10-year material warranty. (see attached)
- Contractor's 10-year workmanship warranty.
- Equipment- reach lift and trucks.
- Freight
- Disposal and dump fees.
- Sales tax
- License(s).

Exclusions:

- Removal and replacement of the existing roof curbs.
- Interior finish work if desired.

Please see the attached product data sheets and warranty information for review and acceptance of this proposal.

This proposal with cost is valid until **June 1, 2024**. Once we have approval to proceed, we will schedule the work and coordinate with the occupants.

Sincerely,



Jay Motz- President
MCM Roofing Company Inc.
License #938303

SOLAR INDUSTRIES, INC.

MANUFACTURER'S WARRANTY

Project:

Anthony Commerce Park
2334 Chicago Way
Chicago, CA 99999

Previous Owner:

N/A

Owner:

Anthony Payton
2334 Chicago Way
Chicago, CA 99999

Contractor:

Walter Construction
2323 Jordon Circle
Chicago, CA 99999

Product:

3434-MANUFACTURED SMOKE VENTS
3434-MANUFACTURED SECURITY BARS

Period:

10 years

Warranty Begins:

January 1, 2222

This limited warranty inures to the benefit of the New Owner only, is non-transferable, and is subject to and limited by the terms and conditions set forth below.

For the period set forth above, SOLAR INDUSTRIES, INC. guarantees the Product will be free from defects in workmanship and material and free from uncontrolled water penetration so long as the Product is installed and maintained in accordance with SOLAR'S recommendations.

The sole and exclusive right of the New Owner in the event of a breach of this warranty is to repair or replacement of the defective Product, at a cost not to exceed the original purchase price of the Product. Under no circumstances shall SOLAR INDUSTRIES, INC. be responsible for incidental, consequential, indirect special, or punitive damages.

This warranty does not cover normal wear and tear or damage caused by misuse, neglect, or accident. This warranty is void if any alterations are made to the Product.

SOLAR INDUSTRIES, INC. reserves the right to make any changes or improvements to its products without incurring any obligation to similarly alter products previously purchased.

THERE ARE NO EXPRESS OR IMPLIED WARRANTIES THAT EXTEND BEYOND THE DESCRIPTION ON THE FACE HEREOF, INCLUDING BUT NOT LIMITED TO THE WARRANTIES OF MERCHANTABILITY AND FITNESS FOR A PARTICULAR PURPOSE. ALL OF SOLAR INDUSTRIES, INC.'S PRODUCTS ARE SOLD AS-IS.

Don Anthony / Manager

Re:S343434-6868pcs – PO#2323-3434

12/04/2222

SkyArc™ Skylights

Product Data Sheet

Acralight Solar's innovative galvanized or aluminum curb mounted or self-flashing skylights feature the Acralight SkyArc™ dome design which provides more light gathering surface area for superior light distribution combined with SkyTough™ glazing for exceptional impact strength. For commercial or industrial applications.

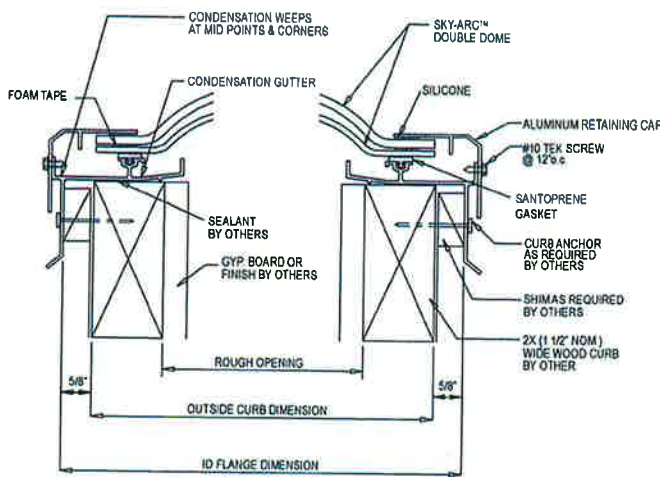

Curb Mounted Skylight

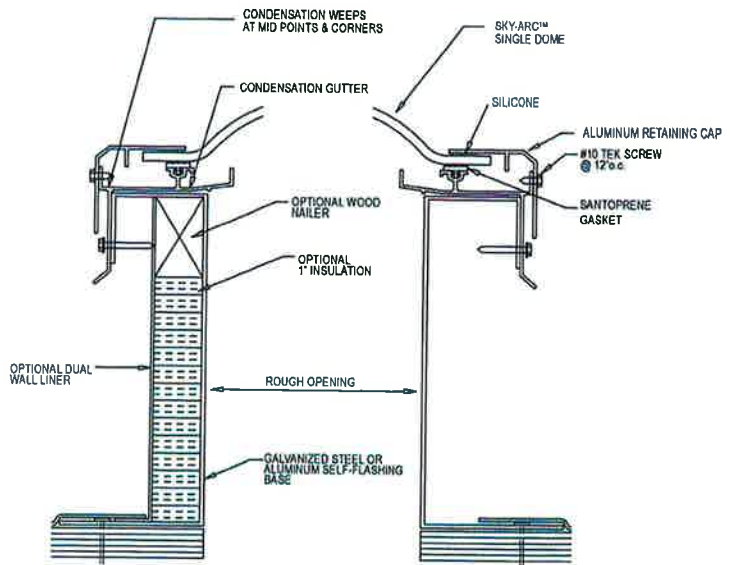

Curb Mounted with Self Flashing Base

Model No. Example: **4896 A-S-CM-ST-MF**

4896 Aluminum frame Skylight Curb Mounted SkyTough-Mill Finish

FM Option Model No. Example: **4896 A-FMS-DD-CM-MF**

4896 Aluminum frame FM Approved Skylight Double Dome Curb Mounted Mill Finish

Model Size:	Rough Opening:
2448	24" x 48"
4848*	48" x 48"
4896*	48" x 96"
6072*	60" x 72"
6096	60" x 96"

* Available in FM Options
Contact us for more sizes

SkyArc™ Design Options:

- Skylights meet current IBC Criteria per ICC Report ESR-2415
- IBC 2012, 2015, 2018, 2021
- Meets UL972 Safety Burglar Resistant Glazing Material FM 4431 Approved Option
- Meets AAMA/WDMA/CSA 101/I.S.2/A440
- Meets CAL OSHA Fall Protection
- Skylight Glazing will be SkyTough™ SkyArc™ polycarbonate
- Single, Double and Triple Domes available
- Thermal Break available
- Louvered base option available
- Self-flashing base available
- Accessories: Recommended Safety Fall Protection

Contact your local Solar Industries, Inc. branch for more information.
solarindustriesinc.com



Technical Specifications: Curb Mounted or Self-Flashing Skylights

Light Transmittance & Thermal Properties

Glazing Material Skylights	U-Factor	SHGC
SkyTough White Polycarbonate	.80	.58
Acrylic over Clear Prismatic	.57	.44
White Polycarbonate over Clear Acrylic	.57	.31
White Acrylic over Clear Acrylic	.56	.45
Bronze Acrylic over Clear Acrylic	.56	.41
White Polycarbonate Triple Dome	.48	.29

← Alternate Included

Infrared Blocking Sheet and other glazing options available

Product Test Data:

Test	Results
ICC ESR Report 2415 - ICC Codes 2015, 2018, 2021	Approved and Listed (ESR-ES 2415)
ICC AC10 Acceptance Criteria for Quality Documentation	Meets ICC-ES Requirements
ICC AC16 Acceptance Criteria for Plastic Glazed Skylights	Meets ICC-ES Requirements
AAMA/WDMA/CSA 101/I.S.2/A440 - For Skylights	Meets all Requirements
NFRC 100-2004 (U-Factor Testing)	Certified Results Available
NFRC 200-2014 (Solar Heat Gain Coefficient Testing)	Certified Results Available
ASTM E283 Air Leakage Test	Meets AAMA A440 and ICC-ES
ASTM E330 Uniform Loading under Static Pressure	Meets AAMA A440 and ICC-ES
ASTM E331 Water Penetration Test	Meets AAMA A440 and ICC-ES
UL 790 Fire Resistance Standard	Meets AAMA A440 and ICC-ES
FM Approval 4431 - Skylights	Tested and Listed by FM



Warranty: Manufacturer's standard 10-year warranty

DISCLAIMER: To facilitate Acralight Solar's commitment for continued product improvements, designs and specifications are subject to change without notice.

Contact your local Solar Industries, Inc. branch for more information.
solarindustriesinc.com



ATTACHMENT 3

Proposal for MCM Roofing Inc. to remove and replace 20 skylights at the Folsom Sports Complex



MCM Roofing Company Inc.

February 6, 2024

Mr. Shane Thompson
City of Folsom
50 Natoma Street
Folsom CA 95630

Via email: sjthompson@folsom.ca.us

APPROVED

Chris O'Keefe

Re: **Proposal for Replacement of (20) Skylights at the Sports Complex**

Shane,

MCM Roofing Company Inc. is pleased to quote a price of \$27,800 (Twenty-Seven Thousand Eight Hundred Dollars) to remove and replace (20) skylights at the Sports Complex in Folsom as requested. Our scope of work has the following inclusions and exclusions.

Inclusions:

- Mobilization with equipment and manpower.
- Removal of the existing (20) skylights for disposal.
- Installation of (20) 48" X 96" dual pane white skylights to fit the existing roof curbs.
- Installation of new foam gaskets around the top edge of the existing curbs.
- Attachment of the skylights with new screws and neoprene washers- placed at every factory attachment hole location.
- Maintain the watertightness of the roof system while the work is performed.
- Manufacturer's standard 10-year material warranty. (see attached)
- Contractor's 10-year workmanship warranty.
- Equipment- reach lift and trucks.
- Freight
- Disposal and dump fees.
- Sales tax
- License(s).

Exclusions:

- Removal and replacement of the existing roof curbs.
- Interior finish work if desired.

Please see the attached product data sheets and warranty information for review and acceptance of this proposal.

Once we have approval to proceed, we will schedule the work and coordinate with the occupants.

Sincerely,



Jay Motz- President
MCM Roofing Company Inc.
License #938303

SOLAR INDUSTRIES, INC.
MANUFACTURER'S WARRANTY

Project:
Anthony Commerce Park
2334 Chicago Way
Chicago, CA 99999

Previous Owner:
N/A

Owner:
Anthony Payton
2334 Chicago Way
Chicago, CA 99999

Contractor:
Walter Construction
2323 Jordon Circle
Chicago, CA 99999

Product: 3434-MANUFACTURED SMOKE VENTS
3434-MANUFACTURED SECURITY BARS
Period: 10 years
Warranty Begins: January 1, 2222

This limited warranty inures to the benefit of the New Owner only, is non-transferable, and is subject to and limited by the terms and conditions set forth below.

For the period set forth above, SOLAR INDUSTRIES, INC. guarantees the Product will be free from defects in workmanship and material and free from uncontrolled water penetration so long as the Product is installed and maintained in accordance with SOLAR'S recommendations.

The sole and exclusive right of the New Owner in the event of a breach of this warranty is to repair or replacement of the defective Product, at a cost not to exceed the original purchase price of the Product. Under no circumstances shall SOLAR INDUSTRIES, INC. be responsible for incidental, consequential, indirect special, or punitive damages.

This warranty does not cover normal wear and tear or damage caused by misuse, neglect, or accident. This warranty is void if any alterations are made to the Product.

SOLAR INDUSTRIES, INC. reserves the right to make any changes or improvements to its products without incurring any obligation to similarly alter products previously purchased.

THERE ARE NO EXPRESS OR IMPLIED WARRANTIES THAT EXTEND BEYOND THE DESCRIPTION ON THE FACE HEREOF, INCLUDING BUT NOT LIMITED TO THE WARRANTIES OF MERCHANTABILITY AND FITNESS FOR A PARTICULAR PURPOSE. ALL OF SOLAR INDUSTRIES, INC.'S PRODUCTS ARE SOLD AS-IS.

Don Anthony / Manager
Re:S343434-6868pcs – PO#2323-3434

12/04/2222

SkyArc™ Skylights

Product Data Sheet

Acralight Solar's innovative galvanized or aluminum curb mounted or self-flashing skylights feature the Acralight SkyArc™ dome design which provides more light gathering surface area for superior light distribution combined with SkyTough™ glazing for exceptional impact strength. For commercial or industrial applications.

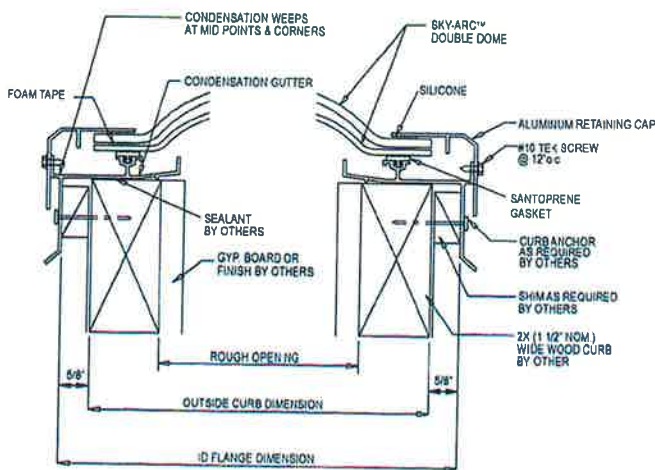

Curb Mounted Skylight

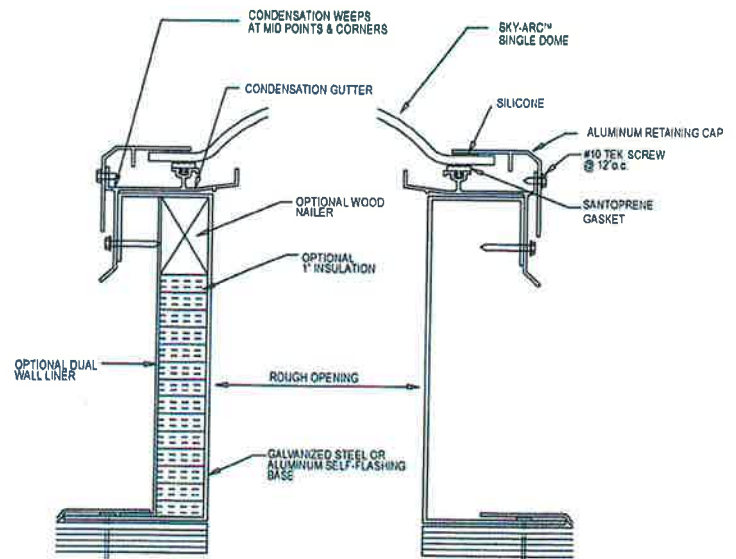

Curb Mounted with Self Flashing Base

Model No. Example: **4896 A-S-CM-ST-MF**

4896 Aluminum frame Skylight Curb Mounted SkyTough-Mill Finish

FM Option Model No. Example: **4896 A-FMS-DD-CM-MF**

4896 Aluminum frame FM Approved Skylight Double Dome Curb Mounted Mill Finish

SkyArc™ Design Options:

Skylights meet current IBC Criteria per ICC Report ESR-2415

IBC 2012, 2015, 2018, 2021

Meets UL972 Safety Burglar Resistant Glazing Material

FM 4431 Approved Option

Meets AAMA/WDMA/CSA 101/I.S.2/A440

Meets CAL OSHA Fall Protection

Skylight Glazing will be SkyTough™ SkyArc™ polycarbonate

Single, Double and Triple Domes available

Thermal Break available

Louvered base option available

Self-flashing base available

Accessories: Recommended Safety Fall Protection

Model Size: Rough Opening:

2448	24" x 48"
4848*	48" x 48"
4896*	48" x 96"
6072*	60" x 72"
6096	60" x 96"

* Available in FM Options
Contact us for more sizes

Contact your local Solar Industries, Inc. branch for more information.
solarindustriesinc.com

7-2022



Technical Specifications: Curb Mounted or Self-Flashing Skylights

Light Transmittance & Thermal Properties

Glazing Material Skylights	U-Factor	SHGC
SkyTough White Polycarbonate	.80	.58
Acrylic over Clear Prismatic	.57	.44
White Polycarbonate over Clear Acrylic	.57	.31
White Acrylic over Clear Acrylic	.56	.45
Bronze Acrylic over Clear Acrylic	.56	.41
White Polycarbonate Triple Dome	.48	.29

~~Alternate~~ Included

Infrared Blocking Sheet and other glazing options available

Product Test Data:

Test	Results
ICC ESR Report 2415 - ICC Codes 2015, 2018, 2021	Approved and Listed (ESR-ES 2415)
ICC AC10 Acceptance Criteria for Quality Documentation	Meets ICC-ES Requirements
ICC AC16 Acceptance Criteria for Plastic Glazed Skylights	Meets ICC-ES Requirements
AAMA/WDMA/CSA 101/I.S.2/A440 - For Skylights	Meets all Requirements
NFRC 100-2004 (U-Factor Testing)	Certified Results Available
NFRC 200-2014 (Solar Heat Gain Coefficient Testing)	Certified Results Available
ASTM E283 Air Leakage Test	Meets AAMA A440 and ICC-ES
ASTM E330 Uniform Loading under Static Pressure	Meets AAMA A440 and ICC-ES
ASTM E331 Water Penetration Test	Meets AAMA A440 and ICC-ES
UL 790 Fire Resistance Standard	Meets AAMA A440 and ICC-ES
FM Approval 4431 - Skylights	Tested and Listed by FM



Warranty: Manufacturer's standard 10-year warranty

DISCLAIMER: To facilitate Acralight Solar's commitment for continued product improvements, designs and specifications are subject to change without notice.

Contact your local Solar Industries, Inc. branch for more information.
solarindustriesinc.com

