



CITY OF  
**FOLSOM**  
DISTINCTIVE BY NATURE

## Folsom City Council Staff Report

<b>MEETING DATE:</b>	4/12/2022
<b>AGENDA SECTION:</b>	Old Business
<b>SUBJECT:</b>	Resolution No. 10838 - A Resolution Authorizing the City Manager to Execute an Updated Fiber Network Installation Agreement with SiFi Networks Folsom LLC for the Installation of a Fiber Optic Network in the City of Folsom
<b>FROM:</b>	Public Works Department

### **RECOMMENDATION / CITY COUNCIL ACTION**

The Public Works Department recommends that the City Council pass and adopt Resolution No. 10838 - A Resolution Authorizing the City Manager to Execute an Updated Fiber Network Installation Agreement with SiFi Networks Folsom LLC for the Installation of a Fiber Optic Network in the City of Folsom.

### **BACKGROUND / ISSUE**

This item was originally discussed at the November 9, 2021 City Council meeting and was continued to the December 14, 2021 meeting in order for staff to contact cities that were under contract with SiFi Networks and currently at some phase of construction. At the December 14, 2021 meeting the Council ultimately voted 3-2 to deny the agreement. SiFi Networks has approached the City of Folsom with an updated license agreement and staff is submitting this updated agreement for the Council's consideration.

SiFi Networks Folsom LLC (SiFi) is a private developer who specializes in Open Access fiber optic networks. SiFi approached City staff earlier this year to propose the installation of a citywide Open Access fiber optic network that they will privately finance and construct. SiFi will wholesale network access to Internet Service Providers (ISPs) which will compete to provide gigabit speed internet services to residents, businesses, institutions, and municipal facilities. The Open Access network is intended to encourage market competition, enable Smart City technological advancements, support healthcare, education, transportation

agencies, government organizations, local businesses and residential neighborhoods, including disadvantaged communities. This will enhance Folsom's competitive advantage when trying to retain or attract new businesses.

The SiFi network will not replace existing ISPs that currently provide service in Folsom (most notably Xfinity and AT&T); however, those existing ISPs may not currently provide all homes and businesses with access to a fiber optic network that allows for symmetrical high-speed internet access. Upon the Fiber Network Installation Agreement being approved by Council, SiFi will be allowed access to the public right-of-way for the purpose of installing a fiber optic network past every premise in the City. The fiber optic network would be constructed using micro-trenching construction and blown micro-duct techniques and would include 35 above-ground cabinets which would be sited in such a way as to minimize the visual impacts to the community.

The agreement has been updated to include a guaranteed maintenance clause that would establish a \$500,000 per year maintenance bond or escrow account that would support SiFi's obligation to restore the public right-of-way upon completion of their fiber installation.

If approved, SiFi and the City will enter into a Fiber Networks Installation Agreement, in a form acceptable to the City Attorney. Per the terms of the agreement, SiFi is expected to initiate fiber network installation with the next 24 months and complete the project within 48 months.

### **POLICY / RULE**

The City Council is the sole authority for entering into agreements between the City and any other party.

### **ANALYSIS**

Prior to the December 14 meeting the Public Works Department reached out to the three cities that are currently in the construction phase of their agreement with SiFi Networks:

1. City of Fullerton, CA. Fullerton was the first City to execute an agreement with SiFi (2014) and is roughly one-third of the way to completion. As the first partner in such a new construction technique and technology, they have had numerous issues and have had to make several adjustments along the way. Most of the issues identified by staff were tied to the performance of the contractor, not SiFi, including the behavior of some of the contractor's personnel and the subsequent, negative public reaction. The current contract is being terminated and a new contractor will come in early next year to finish the project. The poor performance of the first contractor required that SiFi improve their Quality Assurance/Quality Control (QA/QC) methods, and Fullerton requires monthly coordination meetings.
2. City of Salem, MA. Salem initiated their agreement with SiFi in 2018 and were held up to some degree by the Covid-related shutdowns. They are currently wrapping up a

small pilot program wherein they are having SiFi's contractor perform the microtrench/conduit install in a short (2,000 lineal foot) section to see what issues they will encounter. Given that Salem is a 500-year old community, with some roads that were constructed and re-constructed over that span of time using a variety of materials, they are encountering unexpected conditions. It has been a learning experience for both Salem staff and SiFi; in some cases, the contractor was making field deviations without notifying the City, as with the Fullerton experience, SiFi was required to improve their QA/QC methods.

3. City of Placentia, CA. Placentia learned some lessons from Fullerton's experience; nevertheless they are only 20 percent complete after starting construction in July 2021, and have had to amend their agreement with SiFi to reflect lessons learned. They have required that SiFi provide a full-time customer service representative who can be contacted by the community regarding any complaints. Placentia has also required that SiFi reimburse the City for the cost of an independent construction inspector.

All three staff contacts acknowledged that it has been a difficult process and that there have been challenges and frustrations, but in all three cases they felt that the potential benefit to the community is worth it. Covid-related shutdowns and supply chain disruptions have also impacted their schedules, but these are issues outside of the control of SiFi, their contractors, or City staff.

Staff also reached out to major employers/technical partners in Folsom to gauge the value to their companies of a citywide broadband fiber network and their thoughts on the project in general. The firms contacted by staff were:

- Intel Corporation
- PowerSchool
- Safe Credit Union
- Micron
- AT&T

The general consensus of these stakeholders was that the addition of a citywide fiber network may not create new, technological opportunities that they are currently aware of. Safe Credit Union did however note that it could serve as a redundancy/diverse path in case their current fiber services are disrupted.

Most of the stakeholders concurred that access to broadband internet would be a valuable asset for their employees working remotely from home, and a good investment by the City for the general public's benefit. PowerSchool also noted that for smaller employers using shared internet connectivity, the addition of fiber-based broadband could improve latency.

Since December, SiFi has launched their Fiber Network Installation in the City of Rancho Cordova, and has executed agreements with the cities of Pico Rivera, Lynwood, Corona, and Downy – bringing them to a total of twelve partnerships in the State of California with another

seven cities currently considering agreements with SiFi. There are currently three ISPs actively competing on SiFi networks: Ting, GigabitNow, and Flume.

Scott Bradshaw, President of SiFi, and John Marchuk, SiFi's local Project Manager, will be in attendance to respond to any questions regarding their company or the proposed agreement.

### **FINANCIAL IMPACT**

Per the agreement, SiFi will install the fiber optic network at no cost to the City. SiFi also agrees to pay all City plan check fees, permit fees, inspection fees and any other applicable fees.

### **ENVIRONMENTAL REVIEW**

This program is exempt from the requirements of the California Environmental Quality Act per Section 15303, New Construction of Small Structures, and Section 15304, Minor Alterations to Land.

### **ATTACHMENTS**

1. Resolution No. 10838 - A Resolution Authorizing the City Manager to Execute a Fiber Network Installation Agreement with SiFi Networks Folsom LLC for the Installation of a Fiber Optic Network in the City of Folsom
2. Fiber Networks Installation Agreement between SiFi Networks Folsom LLC and City of Folsom

Submitted,



---

Mark Rackovan, PUBLIC WORKS DIRECTOR

# Attachment 1

**RESOLUTION NO. 10838**

**A RESOLUTION AUTHORIZING THE CITY MANAGER TO EXECUTE A FIBER NETWORK INSTALLATION AGREEMENT WITH SIFI NETWORKS FOLSOM LLC FOR THE INSTALLATION OF A FIBER OPTIC NETWORK IN THE CITY OF FOLSOM**

**WHEREAS**, SiFi Networks Folsom LLC desires to install a fully privately funded fiber optic network in the City of Folsom; and

**WHEREAS**, the City of Folsom seeks, without City or public funds, to enable the deployment of fiber optic infrastructure for broadband for the City's residents and businesses; and

**WHEREAS**, the provision of broadband to the City's residents and businesses will stimulate economic development, encourage market competition, enable Smart City technological advancements, and support healthcare, education, transportation, and government; and

**WHEREAS**, the fiber optic network will also provide opportunities for additional Smart City services, including connected buildings, traffic signals and other City facilities; and

**WHEREAS**, if approved, the City would grant SiFi Networks Folsom LLC a license and encroachment permit to access the public right-of-way for the purpose of installing the fiber optic network; and

**WHEREAS**, the fiber network installation agreement will be in a form acceptable to the City Attorney:

**NOW, THEREFORE, BE IT RESOLVED** that the City Council of the City of Folsom hereby authorizes the City Manager to execute a Fiber Network Installation Agreement with SiFi Networks Folsom LLC for the installation of a fiber optic network in the City of Folsom.

**PASSED AND ADOPTED** this 12<sup>th</sup> day of April 2022, by the following roll-call vote:

**AYES:** Councilmember(s):  
**NOES:** Councilmember(s):  
**ABSENT:** Councilmember(s):  
**ABSTAIN:** Councilmember(s):

\_\_\_\_\_  
Kerri M. Howell, MAYOR

ATTEST:

\_\_\_\_\_  
Christa Freemantle, CITY CLERK

## Attachment 2

## FIBER NETWORKS INSTALLATION AGREEMENT

This Fiber Networks Installation Agreement is made this \_\_ day of April, 2022 (“**Effective Date**”) as it may be extended or amended, the “**Agreement**”), between the City of Folsom, California, a municipal corporation (the “**City**”) and SiFi Networks Folsom LLC, a Delaware limited liability company (“**SiFi Networks**” or “**SiFi**”) (each sometimes referred to as a “**Party**” and collectively referred to as the “**Parties**”).

### **RECITALS**

**WHEREAS**, SiFi Networks owns the rights to the FOCUS (as defined below) proprietary fiber optic cable system technology; and

**WHEREAS**, SiFi Networks desires to install a fully privately funded fiber optic network utilizing FOCUS in the City; and

**WHEREAS**, SiFi Networks has requested that the City grant a license and an encroachment permit to access and use the City’s Public Right-of-Way (“**Public Way**”, as defined below) for purposes of installing the FON (as defined below) in the City; and

**WHEREAS**, City seeks, without City or public funds, to enable the deployment of fiber optic infrastructure for broadband for the City’s residents and businesses, in order to stimulate economic development, to encourage market competition, to enable Smart City technological advancements, and to support healthcare, education, transportation agencies, government organizations, local business, and residential neighborhoods;

**WHEREAS**, the City is agreeable, without City or public funding, to grant to SiFi Networks a license and an encroachment permit to access and use the Public Way for SiFi Networks in order to install and operate the FON including a point of presence and/or a series of distributive cabinets and other equipment and materials in connection with the installation of the FON, pursuant to the terms and conditions set forth herein;

**WHEREAS**, the FON will provide opportunities for Smart City additional services, including but not limited to connecting buildings, traffic lights, and other City owned locations, to the City subject to a separate written mutual agreement between the Parties; and

**NOW, THEREFORE**, in consideration of the mutual obligations of the Parties, and other good and valuable consideration, the receipt and sufficiency of which are acknowledged, the Parties covenant and agree as follows:

### **SECTION 1**

1. **Definition of Terms.**

1.1 **Terms.** For the purpose of this Agreement, the following terms, phrases, words, and abbreviations shall have the meanings ascribed to them below.



“**Access**” means facilitation of City permitted encroachments for specified areas within the Public Way.

“**Boundary**” means the legal boundaries of the City as of the Effective Date, and any additions or subtractions to the City legal boundaries, by annexation or other legal means.

“**Cabinets**” means above ground enclosures placed within the Public Way for the protection of active and passive equipment for the provision of Service throughout the System and as further described in Exhibit A.

“**Chambers**” means underground enclosures placed within the Public Way facilitating access to the active and passive equipment for the provision of Service throughout the System.

“**Commencement Date**” means the date that Substantial Completion, as that term is defined herein, of the System has been achieved.

“**Construction**” means breaking ground for the installation of the System.

“**Construction Contractor**” or “**Contractor**” means the construction company(ies) performing the physical work for or on behalf of SiFi Networks.

“**Drop**” means the fiber optic cable run from the edge of the Public Way to the Premises Wall.

“**Facility**” means the secure space/s that the City agrees to make available to SiFi Networks during the Term for the installation of Shelters and Cabinets.

“**FOCUS**” means SiFi Networks’ trademarked FOCUS™ system including the patented Wastewater Fiber Technology, know-how and other proprietary rights, comprising, among other things a combination of blown fiber, aerial, wastewater and other conventional techniques to enable multi gigabit technologies.

“**FON**” means SiFi Networks’ fiber optic network built by utilizing a combination of blown fiber, aerial, wastewater and/or other conventional techniques and may also include using the FOCUS™ design, as well as electronics to enable multi gigabit technologies.

“**Hazardous Materials**” means (i) any hazardous or toxic wastes, substances, or materials, and any other pollutants or contaminants, which are regulated by any applicable local, state or federal laws, including, but not limited to 33 U.S.C. Section 1251 et seq., 42 U.S.C. Section 6901 et seq., 42 U.S.C. Section 9601 et seq., 42 U.S.C. Section 7401 et seq., 42 U.S.C. 960 et seq., and the California Health and Safety Code Section 25100 et seq., and 25300 et seq., the California Water Code, Section 13020 et seq., or any successor(s) thereto: (ii)

petroleum; (iii) asbestos; (iv) flammable explosives; (v) polychlorinated biphenyls; and (radioactive materials).

“**Home**” means a residential single-family dwelling, or a residential single dwelling unit located within a Multiple Dwelling Unit, located within the Boundary.

“**Multiple Dwelling Unit**” means an apartment building or other building containing more than one dwelling unit located within the Boundary.

“**Microtrenching**” means the process of cutting a trench with a dry cut machine and reinstated with cementitious slurry fill as specified in Exhibit A.

“**Pass**” or “**Passes**” means the duct or Chamber as parts of the System has reached to the curbside of a residential Premises, or the engineered point at or near a commercial Premises from which a Drop can be connected.

“**Person**” means any natural person or any association, firm, partnership, joint venture, corporation, limited liability company, or other legally recognized entity, whether for profit or not for profit, but shall not mean the City or SiFi Networks.

“**Premises**” means a Home, Multiple Dwelling Unit, office or other building located within the Boundary.

“**Premises Wall**” means the exterior of an outside wall of a Premises to which the fiber optic cable can be terminated.

“**Primary Premises**” means the Premises within the Boundary as of the Effective Date but excluding any Premises which SiFi cannot connect (i) because of a lack of a right to access and use the Public Way due to the City not possessing the right, title, interest or authority to permit SiFi to use and occupy the Public Way in order for SiFi to access such Premises, or (ii) because SiFi lack of a right to access any non-City owned property within the Boundary in order to access such Premises, or (iii) if there would be an incremental material cost to connect such Premises would be at least ten percent (10%) higher than the average cost to connect accessible by SiFi Primary Premises within the Boundary; provided that, (1) at least ninety-five percent (95%) of Premises within the Boundary are Passed, and (2) no Premises are excluded for any other reasons other than technical or cost reasons as described herein, or (iv) where such Premises already have a pre-existing fiber service available to them and do not desire SiFi to connect such Premises. SiFi shall not be required or obligated to make the System available to such Primary Premises described in (i) through (iv) in this definition and Substantial Completion determination shall not be impacted as a result. If any Premises are excluded under subsection (iii) above, City will have the option to request SiFi meet and confer regarding potential solutions, including the use of any City owned or controlled conduit, duct or other similar

facility, to Pass such Premises, which solutions would have to be mutually agreed in good faith and in writing between the Parties. **“Public Way”** shall mean City-owned public right-of-way, including the surface of, and the space above and below, existing now or in the future City owned land. Public Way includes City-owned public street, road, highway, parkway, driveway, freeway, lane, path, court, sidewalk, bridge, alley, boulevard, traffic signals, lamp post, public way, or other public right of way or easement including public utility easements dedicated utility strips, located thereon now or hereafter held by, granted or dedicated to or under the jurisdiction of the City within the Boundary. For the avoidance of doubt, the term **“Public Way”** shall also mean any easement now or hereafter held by the City within the Boundary for the purpose of public travel, or for utility service use.

**“Release”** when used with respect to Hazardous Material means any actual or imminent spilling, leaking, pumping, pouring, emitting, emptying, discharging, injecting, escaping, leaching, dumping, or disposing into or inside any existing improvements or any improvements constructed hereunder, including the System.

**“Service”** means internet, voice, data, and video service or any combination thereof, provided by the City or another Service Provider over the System.

**“Service Providers”** means any entity, which enters into a contract with SiFi Networks to provide Services over the System.

**“Shelter”** means the above ground facility housing System equipment as further described in Section 4.2 and in Exhibit A hereto.

**“Subscribe”** means an agreement to receive from a Service Provider.

**“Subscriber”** means any Person (which for purposes of this definition shall include the City) that has entered into an agreement to receive or otherwise lawfully receives Service.

**“Substantial Completion”** means the date on which, the System has been installed such that it Passes the addresses of each of the Primary Premises and the System is capable of providing Service to each such Primary Premises (but for the lack of a Drop) or four (4) years post Construction being commenced, whichever event occurs first; provided, however, in the event that Substantial Completion is deemed to have occurred due to the expiration of four (4) years post Construction being commenced, SiFi shall use commercially reasonable efforts to complete, subject to the conditions in the proviso above, such construction as is necessary to provide service to all Primary Premises within a commercially reasonable time.

**“System”** means all parts of the FON system under and above ground in the City that is designed to support the delivery of Service to Subscribers,

including the fiber optic cable and its component parts and appurtenances, and the other cables, wires, components, facilities, cabinets, ducts, conduits, connectors, vaults, Chambers, telecom manholes, telecom manhole covers, pedestals, appliances, splitters, attachments, and other property, equipment, components, materials, apparatus and appurtenances to the FON system.

## SECTION 2

### 2. Grant of License.

#### 2.1 Grant of Temporary and Non-Exclusive License.

2.1.1 License to Use City Public Way. This Agreement sets forth the basic terms and conditions upon which SiFi is hereby granted a non-exclusive no cost, except for payment of applicable City fees, license, during the Term, to install, operate and maintain the System in the Public Way. The particular terms and location of each portion of the System shall be specified in the applicable permit approved by the City as described in Section 3.2 Permits and General Obligations. Provided SiFi Networks' is not in breach of this Agreement and the applicable permits, City grants to SiFi Networks a non-exclusive no cost license, during the Term, to erect, install, construct, repair, replace, reconstruct, maintain, operate or retain in, on, over, under, upon, across, or along any Public Way, the System, within the Boundary, and all extensions and additions thereto. SiFi Networks shall have the right to determine the final engineering design and location of all equipment and other parts of the System, subject to the City's prior written approval for their placement. Both Parties agree to cooperate during the design and permitting process and SiFi Networks must first disclose all engineering designs to the City for permit approval. Notwithstanding the foregoing, installation of the System and access to and use of the Public Way is subject to the applicable permit for a specific location. It is understood that SiFi's license to place the System is non-exclusive, except for the Facilities, but that upon issuance of the applicable permit, SiFi's use of the area specified therein shall not be unreasonably interfered by the City or its contractors. Further, in the event of a material breach of this Agreement by SiFi, SiFi's license granted under this Agreement and the particular permit are revocable only if SiFi Networks fails to cure any alleged breach as described in Section 8.1, prior to the expiration or earlier termination of this Agreement.

2.1.2 Abandonment of the System upon Termination of Agreement. Upon the expiration or termination of this Agreement, SiFi Networks shall have the right, but not the obligation, to remove from or abandon in place all or any part of the System in the Public Way. Any part of the System abandoned by SiFi Networks as described in this Agreement shall become the property of the City. Within ninety (90) days prior to the expiration or termination of this Agreement, SiFi must notify the City in writing of its intent not to abandon the System. Failure to provide such written notice within the time specified shall be deemed abandonment upon the expiration or termination of the Agreement.

2.2 **Term of Agreement.** This Agreement shall become effective upon the execution and delivery of this Agreement by the Parties (the “**Effective Date**”). The term of this Agreement shall commence on the Effective Date and run until midnight on the date that is thirty (30) years after the Commencement Date (the “**Initial Term**”). No later than one year prior to the expiration of the Term, SiFi may submit a request in writing that the City approve renewing this Agreement for an additional term of fifteen (15) years, commencing on the thirtieth (30th) anniversary of the Commencement Date (“**Renewal Terms**,” and, collectively with the Initial Term, the “**Term**”), which approval shall not be unreasonably withheld. If SiFi Networks elects to not renew this Agreement the System will be deemed abandoned and shall become the property of the City.

2.3 **License to City-owned property.**

(i) City hereby grants, at no additional charge, to SiFi, and its licensees, successors, lessees, transferees, and assigns, a revocable non-exclusive license during the Term of the Agreement (“License”) to enter and occupy portions of the City-owned property in or outside of the Public Way for up to two (2) specific locations as further described in Section 4.2 and from the System in the Public Way to each of the Facilities, which locations will be mutually agreed upon in writing and in good faith between the City and Licensee (the “License Area”), for the purposes of erecting, installing, constructing, operating, repairing, replacing, reconstructing, removing, maintaining, using and retaining said System, including, without limitation, wires, cables, ducts, conduits, connectors, vaults, manholes, manhole covers, fencing, pedestals, appliances, splitters, attachments, and other property, equipment, components, materials, apparatus and appurtenances to the System and the Facilities (the “Improvements”). This License is subject to easements, covenants, conditions, and regulations in existence as of the date hereof.

(ii) Subject to easements, covenants, conditions, and regulations in existence as of the date hereof, SiFi shall be permitted to use microtrenching for fiber optic cables and make such alterations to the License Area as approved, which approval shall not be unreasonably withheld, delayed, or conditioned, by the City to erect, install, construct, repair, replace, reconstruct, remove, maintain, operate, and use, the System including, without limitation, the Improvements, and adding and moving electrical lines and other utilities and apparatus. SiFi shall be responsible for all costs incurred in the alterations. All construction, installation, maintenance and repair of the License Area shall be conducted so as to interfere as little as practicable with City’s use and operation of the Public Way. The installation of the System and alterations by SiFi in the License Area shall be done in a good and workmanlike manner by competent personnel or contractors, and except for the specifications and construction techniques approved in this Agreement, in conformity with all applicable permits, licenses, ordinances, laws and regulations, free from any liens for labor or materials, and subject to final inspection and approval by the City. Any damage to the License Area caused by reason of the exercise of SiFi’s rights

hereunder shall be corrected within a reasonable time by SiFi at its sole cost and expense.

(iii) SiFi will maintain the Improvements in accordance with this Agreement.

(iv) SiFi shall not install or construct any other structures or improvements other than the Improvements and associated appurtenances described herein.

(v) The Improvements installed within the License Area by SiFi shall be made at no expense to City. SiFi shall be responsible, and assume all costs, for any relocation or protection of any part of the System in the event the relocation or protection of the System is necessary due to changes in any Public Way at any time during the term of this Agreement.

(vi) Other than SiFi's obligation to repair any damage SiFi or SiFi's contractors cause to the City's Public Way at its sole cost and expense, City, at its sole cost, shall operate, maintain and repair the Public Way so as to avoid damage or minimize adversely affecting the System and the License Area. City shall not make any modifications to, or alter, the License Area without prior written notice to SiFi.

(vii) City, its agents, or assigns, or any utility company or City franchisee may at any time, enter upon the areas covered by this Agreement for the purpose of installing, maintaining, relocating, altering, enlarging, repairing, or inspecting any utility, facility, or public work thereon. City will not be liable to SiFi for any damages to the System, Improvements and Facilities.

(viii) SiFi shall restore damaged or disturbed surfaces or underground utilities at or adjacent to the License Area to substantially the same as the original condition. Restoration shall be carried out immediately after construction. Any damage not repaired to the satisfaction of the City shall be a cause to suspend any operations within the City's limits by the party causing the damage until the repairs are satisfactory to the City.

(ix) The System and all of its parts and components which are installed and constructed by SiFi in the License Area shall at all times be and remain the property of SiFi.

(x) Except for the Facilities, City shall not unreasonably impede, disturb, interfere with, or restrict, SiFi's access to, use and possession of, the License Area.

(xi) Notwithstanding any provision to the contrary, whenever possible SiFi shall not install any Improvement, when running parallel, within 3 feet from existing underground utilities, and further shall not install any Improvement above or on top of water or sewer pipelines except with express written authorization by the Environmental and Water Resources Department of the City.

(xii) Notwithstanding any provision to the contrary, in the event SiFi or its contractor damages water or sewer infrastructure, SiFi shall immediately notify the City and shall further make the repair, or cause to be repaired, the damaged infrastructure within 4 hours. At the City's sole and completion discretion, City may permit SiFi to pay City to make the necessary repairs at SiFi's sole cost and expense.

2.4 (xi) The terms, conditions and rights contained herein shall be covenants running with the land and shall remain in effect for as long as the Agreement remains in effect. Within thirty days after termination of this Agreement, SiFi shall remove any abandoned or unused Improvements from the Public Way. The terms and conditions contained herein shall bind, inure to the benefit of, and be enforceable by, City and SiFi, and their respective successors and assigns (including, without limitation, any and all successors to City in title to all or any portion of the Public Way).

**2.4 City Accommodation.** SiFi Networks acknowledges that this Agreement is entered into by the City to accommodate SiFi Network's request, that the City would not have entered into this Agreement had it been exposed to liability for damages from SiFi Networks, and that therefore and notwithstanding any provision to the contrary, SiFi Networks hereby waives any and all claims for damages against the City and its officers, agents and employees for breach of this Agreement. SiFi Networks further acknowledges that damages are not a remedy under this Agreement, and therefore and notwithstanding any provision to the contrary, SiFi Networks waives all claims for damages against the City and its officers, agents and employees in the event that this Agreement or any other permit or land use entitlement is: (1) not approved by the City or (2) is approved by the City but with new changes, amendments, conditions or deletions to which SiFi Networks is opposed.

2.5 **Exclusivity.** Until after the first anniversary of the Effective Date, the City shall not solicit any third party regarding any competing fiber optic cable system within the City's Boundary, subject to any obligation or requirements imposed upon the City in its capacity as a land use authority under federal or state law or regulation.

## 2.6 **Efficient Permitting Process.**

2.6.1 During the Term, the City shall endeavor to provide expedited, diligent review of all applications for permits by SiFi and/or its contractors, to the extent reasonably possible and to the extent permits are necessary, including permits or other necessary items for construction work on the System within the Public Way. The City acknowledges and agrees that expeditiousness in connection with permitting, licensing, and approval of the System is important to SiFi Networks' performance under this Agreement. Accordingly, the City agrees to endeavor to the process and

timeframes below in connection with all applications for permits by SiFi Networks and/or its contractors in connection with this Agreement:

(i) If possible, the City shall within two (2) business days of submittal by SiFi Networks and/or its contractors of an application or other request for a permit in connection with this Agreement provide written acknowledgment to SiFi Networks and/or its contractor confirming receipt of such submittal; and

(ii) If possible, the City shall within seven (7) business days of submittal by SiFi Networks and/or its contractors of an application or other request for a permit in connection with this Agreement acknowledge in writing that such application is properly submitted and complete, or in the event such application is not properly submitted and complete, provide SiFi Networks and/or its contractors with a detailed written explanation of any deficiencies. Upon curing any such deficiencies, the City shall undertake an expedited review of the application or other request for permit by SiFi Networks and/or its contractors in order to comply with this Section.

(iii) If possible, the City shall within fifteen (15) calendar days of submittal by SiFi Networks and/or its contractors of an application or other request for a permit in connection with this Agreement provide written notification of initial review and provide in writing to SiFi Networks and/or its contractors a detailed explanation of any additional information needed for the City to complete its review process. In the event no additional information is needed, the City shall so notify SiFi Networks and/or its contractors in writing.

(iv) If possible, the City shall within twenty-one (21) calendar days of submittal by SiFi Networks and/or its contractors of an application or other request for a permit in connection with this Agreement provide final approval and issue any necessary approval or permits to SiFi Networks and/or its contractors.

(v) The aforementioned timelines are subject to extension by City in the event information or document reasonably necessary or required to process the requested permit is not submitted by SiFi Networks or its contractors in a timely manner.

2.6.2 **Invoices and Payments.** SiFi agrees to pay all City permit review and processing fees (as set and adjusted by the City from time to time) associated with SiFi's work under and subject to this Agreement, including but are not limited to plan check fees, encroachment permit fees, inspection fees, and any other applicable fees for SiFi's work.



2.6.3 Permit applications shall be submitted by SiFi Networks in substantially the form required by the City. The engineering details provided in Exhibit A are a sample of typical details that may or may not change during the final engineering design process.

2.6.4 No permit, license, or other land use approval of any other approval requested by or required from SiFi Networks shall be unreasonably withheld, conditioned or delayed by the City. Furthermore, SiFi Networks shall have no liability for any of its obligations hereunder (except for payment of City fees), if the necessary permits, licenses or approvals are not issued by the City. City retains all rights to deny applications not meeting applicable laws, rules and regulations.

2.7 **Other City charges.** In recognition of the public benefit being served in encouraging and facilitating the construction of the fully privately funded SiFi's System and other valuable consideration and benefits to City and the public gained from and due to the System, City agrees that SiFi shall not have to pay for use of the Public Way. Except as expressly set forth herein, each Party shall bear and be responsible for all of its own costs, fees and expenses incurred in executing and performing this Agreement. The City agrees that this Agreement shall not require SiFi Networks to comply with or otherwise be subject to any obligations or liabilities as a grantee of a franchise under the City's municipal code, ordinances or similar laws. The City agrees that City bonding and insurance requirements will be satisfied by bonds and insurance coverage provided as part of the encroachment permit application and supplied by the Construction Contractor (as principal) performing the construction of the System. Such bonds and insurance documentation to be supplied prior to the start of Construction. Notwithstanding anything to the contrary contained in this Agreement, the provisions of this Section 2.6 will survive expiration or termination of this Agreement.

2.8 **Relocation, Modification, or Alternations.** Excluding relocations requested by the City pursuant to this Agreement and repairs or maintenance to the System, SiFi may not relocate, materially modify, or materially alter the System components any time after issuance of the permit(s) for the System, except upon City's written approval which approval will not be unreasonably withheld, delayed, or conditioned.

2.9 **SiFi's Maintenance Security.** As of the date of completion of construction of the work authorized by the first construction permit within the Public Way and on the first business day of each anniversary thereafter in order to support SiFi's obligations to restore the condition of the Public Way directly impacted by the construction of the System, SiFi will provide to the City and maintain or substitute throughout the Term of this Agreement, either of the following, at SiFi's sole option by providing ninety (90) days advanced written notice: (i) a maintenance bond in accordance with the City's bonding requirements, (ii) letter of credit from a bank of SiFi's choosing, or (iii) cash in escrow, subject to

a mutually agreed escrow agreement, in an aggregate annual amount not to exceed five hundred thousand dollars (\$500,000.00).

### SECTION 3

#### 3. The System.

3.1 **System Description.** SiFi Networks agrees to install the System within the Boundary using the Public Way, and further agrees to install, subject to a separate written agreement, the System to link at substantially below market rates City buildings and facilities including but not limited to traffic signals and municipal buildings within 4 years of commencement of Construction. The City will provide SiFi Networks a comprehensive list of locations and prioritization. The System shall use fiber optic cable emanating from the Shelter to the applicable Cabinet in the Public Way and then to the private Premises Wall for each applicable Primary Premise. The City acknowledges and agrees that SiFi Networks has the right to install the System within the Boundary using the Public Way in order to make the delivery of Service over the System available to all Premises within the Boundary. The Parties acknowledge and agree that there is no agreed design or configuration of the actual location of the System within the Public Way at this time and that SiFi Networks shall submit such designs specification, plan and associated details to the City for approval when ready. The City will work with SiFi Networks to approve the physical location of the fiber optic cable and other equipment and components of the System in, on, over, under, upon, across, or along the Public Way and from the Public Way to the Premises Wall.

3.2 **Permits and General Obligations.** SiFi is deemed to have approval to locate the System within the Boundary, subject to applicable permits including but not limited to encroachments, licenses, or other forms of plan review and approval or authorization necessary to construct, install, operate, maintain, replace, reconstruct, or repair the System, or any part thereof, during the term of this Agreement and any extensions. Nothing herein entitles SiFi Networks to access or encroach upon private property without permission of the property owners. SiFi Networks shall provide plans to the City for City approval for the issuance of permits to construct the System. Construction and installation of the System shall be performed in a safe manner using materials of good and durable quality. Other than for the construction techniques agreed in Section 4.1 and described in Exhibit A, all permits shall be subject to the provisions set forth in the City's latest Encroachment Permit and Construction Specifications listed at <https://www.folsom.ca.us/community/engineering/specs.asp> and unless otherwise stated in this document. Subject to compliance with the City's Noise Control Ordinance listed at <https://www.codepublishing.com/CA/Folsom/html/Folsom08/Folsom0842.html>, standard work hours will be daily from 7am to 7pm local time unless City has different requirements which must be provided to SiFi Networks in advance. All transmission and distribution structures and equipment installed by SiFi Networks for use in the System in accordance with the terms and conditions of this Agreement shall be

located so as to minimize interference with the proper use of the Public Way and the rights of property owners who own property that adjoin any such Public Way. SiFi Networks shall provide, or cause to be provided by its contractors, all necessary traffic control measures and warning signage for the protection of pedestrian and vehicular traffic. No installation in the City's Sewer and storm drainage system will be permitted. SiFi Networks will adhere to all City building code requirements; provided, however in the event of an inconsistency or conflict between the permits granted to SiFi Networks pursuant to this Agreement and the most current City building code provision, the City building code provision shall control other than for (i) the construction techniques agreed in Section 4.1 and described in Exhibit A, and (ii) previously constructed portions of the System.

## SECTION 4

### 4. Construction and Facilities.

4.1 **Construction of the System.** SiFi Networks will use commercially reasonable efforts to commence Construction on or before a date that is twenty-four (24) months after the Effective Date (the "**Construction Commencement Deadline**"); provided however, in the event of a Force Majeure Event, the Construction Commencement Deadline shall be extended by the time impact resulting from the Force Majeure Event. In addition, SiFi Networks will use commercially reasonable efforts to complete construction of the System on or before a date that is forty eight (48) months after the Construction Commencement Deadline (the "**Construction Completion Deadline**"); provided however, in the event of a Force Majeure Event, the Construction Completion Deadline shall be extended by the time impact resulting from the Force Majeure Event. The timeline shall also be extended due to and for the length of any delay by the City in performing its obligations hereunder or issuing the permits, licenses and approvals to SiFi or its contractors. Both Parties recognize and agree that SiFi Networks cannot guarantee the Construction Commencement Deadline or the Construction Completion Deadline as many elements are outside of its control. SiFi Networks will keep the City informed of the progress of its schedule at reasonable intervals.

SiFi agrees it shall make reasonable efforts to collaborate and coordinate with City in the installation of the System ahead of planned asphalt overlay projects by City. Notwithstanding any provision to the contrary, SiFi Networks agrees that it will only use slot cut micro-trenching as set forth in the specifications set forth in Exhibit A to this Agreement for all work in the City's Public Way. City approves only the above referenced construction method and agrees to work cooperatively with SiFi Networks in reviewing all other potential construction methods; however, the City retains all rights to disapprove at the City's sole and complete discretion any other construction method it does not approve.

4.1.2 SiFi shall be solely responsible for all repairs, maintenance, and adjustments, and damages, caused by SiFi or its contractors, to the System and City-owned property used by SiFi Networks under this Agreement and not

caused by City's sole negligence or willful misconduct. The City shall be liable to the extent any loss or damages to the System or other SiFi property and equipment results from the sole negligence or willful misconduct of acts or omissions the City or its employees or contractors.

#### 4.2 **Location of Equipment/Facilities.**

4.2.1 **Facilities.** During the Term and if approved by the City in accordance with this Agreement, the City shall permit SiFi Networks access and grant a License to and use of the Facilities on City-owned property, at market rate to SiFi Networks for the installation and operation of SiFi Networks' Shelters (approximately 1,000 square feet per location), distributed cabinets and other System equipment, components, parts, and other appurtenances for the System and related facilities, and from which the fiber optic cables will be deployed, and SiFi Networks shall pay all costs of electricity required for such Shelters.

4.2.2 **Shelters and Cabinets Location.** SiFi Networks agrees to provide engineering designs including intended locations of Shelters and Cabinets required for the System to the City prior to Construction in accordance with City's permitting process. The City and SiFi Networks agree to cooperate in the selection of suitable sites for the Shelters and Cabinets. However, City has sole and absolute discretion to reject a proposed location; provided that, the City will use reasonable efforts to consider suitable alternative locations.

#### 4.3 **Subscriber Connections.**

4.3.1 **Fiber to the Premises Wall.** SiFi Networks will provide a terminated fiber to each Subscriber's Premises receiving a Drop in a manner to be determined by SiFi Networks. The location and the method of the Drop will vary depending on the circumstances of the location of the Subscriber's Premises.

4.3.2 **System Connection to the Premises Wall.** The following will apply to the connection to each Premises receiving a Drop:

(i) SiFi Networks or its designee shall be solely responsible for securing private property easement access rights necessary, advisable or appropriate to connect the System from the Subscriber property boundary to the Premises Wall. For the avoidance of doubt, in the event SiFi Networks cannot install fiber optic cable or other necessary equipment on private property because of a lack of a right to access the property, SiFi Networks shall not be required to make the System available to such Premises.

(ii) SiFi Networks shall have no duty to provide any additional connection after the terminated fiber has been taken to the ONT on the Premises Wall.

## SECTION 5

### 5. **Oversight and Regulation by City.**

5.1 **Oversight of Construction.** In accordance with applicable law, the City shall have the right to oversee and inspect the Construction of the System in the Public Way.

5.2 **Compliance with Applicable Laws.** SiFi Networks shall, at all times during the Term, be subject to and comply with all applicable federal, state laws and local laws regarding the Construction of the System in the Public Way.

5.3 **Treatment of SiFi Provided Information.** The City agrees to notify SiFi Networks if the City receives a California Public Records Act request relating to SiFi Networks provided information and documents or the System.

## SECTION 6

### 6. **Insurance.**

SiFi shall procure at its sole expense and maintain from the Effective Date and for the duration of the Term of the Agreement, insurance against claims for injuries to persons or damages to property which may arise from or in connection with the performance of the work hereunder by the SiFi, its agents, representatives, employees, or subcontractors.

#### 6.1 **Minimum Scope and Limit of Coverage.**

Coverage shall be at least as broad as:

A. Commercial General Liability (CGL): Insurance Services Office (ISO) Form CG 00 01 covering CGL on an "occurrence" basis, including products and completed operations, property damage, bodily injury and personal & advertising injury with limits no less than \$1,000,000 per occurrence. If a general aggregate limit applies, either the general aggregate limit shall apply separately to this project/location (ISO CG 25 03 or 25 04) or the general aggregate limit shall be twice the required occurrence limit. Coverage shall include blanket contractual liability and broad form property damage, premises, operations, explosion, collapse, underground hazard (commonly referred to as "X", "C" and "U" coverages

B. Automobile Liability: Insurance Services Office Form CA 0001 covering Code 1 (any auto), with limits no less than \$1,000,000 per accident for bodily injury and property damage.

C. Workers' Compensation insurance as required by the State of California, with Statutory Limits, and Employers' Liability insurance with a limit of no less than \$1,000,000 per accident for bodily injury or disease.

D. Builder's Risk (Course of Construction) insurance utilizing an "All Risk" (Special Perils) coverage form, with limits equal to the completed value of the project and no coinsurance penalty provisions.

E. Professional Liability with limits no less than \$1,000,000 per occurrence or claim, and \$2,000,000 policy aggregate. The retroactive date must be shown, and this date must be before the execution date of the contract or the beginning of contract work. Insurance must be maintained, and evidence of insurance must be provided for at least five (5) years after completion of contract work. If coverage is canceled or non-renewed, and not replaced with another claims-made policy form with a retroactive date prior to the contract effective, or start of work date, the SiFi must purchase extended reporting period coverage for a minimum of five (5) years after completion of contract work. A copy of the claims reporting requirements must be submitted to the City for review.

F. Pollution Legal Liability and/or Asbestos Legal Liability and/or Errors and Omissions (if project involves environmental hazards) with limits no less than \$1,000,000 per occurrence or claim, and \$2,000,000 policy aggregate. If the services involve lead-based paint or asbestos identification/remediation, the Pollution Liability policy shall not contain lead-based paint or asbestos exclusions. If the services involve mold identification/remediation, the Contractors Pollution Liability policy shall not contain a mold exclusion, and the definition of Pollution shall include microbial matter, including mold.

If the Contractor or SiFi maintains broader coverage and/or higher limits than the minimums shown above for all policies, the City requires and shall be entitled to the broader coverage and/or higher limits maintained by the Contractor or SiFi. Any available insurance proceeds in excess of the specified minimum limits of insurance and coverage shall be available to the City to the extent necessary to cover any actual damages suffered by the City.

## **6.2 Self-Insured Retentions**

Self-insured retentions must be declared to and approved by the City. At the option of the City, SiFi shall cause the insurer to reduce or eliminate such self-insured retentions as respects the City, its officers, officials, employees, and volunteers; or SiFi shall provide a financial guarantee satisfactory to the City guaranteeing payment of losses and related investigations, claim administration, and defense

expenses. The policy language shall provide, or be endorsed to provide, that the self-insured retention may be satisfied by either the named insured or City.

### **6.3 Other Insurance Provisions:**

**A. Additional Insured.** The City, its officers, officials, employees, and volunteers are to be covered as additional insureds on the CGL and automobile policy with respect to liability arising out of work or operations performed by or on behalf of SiFi including materials, parts, or equipment furnished in connection with such work or operations and automobiles owned, leased, hired, or borrowed by or on behalf of SiFi. General liability coverage can be provided in the form of an endorsement to the Sifi's insurance (at least as broad as ISO Form CG 20 10 11 85 or both CG 20 10, CG 20 26, CG 20 33, or CG 20 38; and CG 20 37 forms if later revisions used).

**B. Primary and Non-Contributory Insurance.** For any claims related to this project, SiFi's CGL and automobile insurance coverage shall be primary insurance coverage at least as broad as ISO CG 20 01 04 13 as respects the City, its officers, officials, employees, and volunteers. Any insurance or self-insurance maintained by the City, its officers, officials, employees, or volunteers shall be excess of the SiFi's insurance and shall not contribute with it.

**C. Notice of Cancellation.** SiFi shall provide immediate written notice if (1) any of the required insurance policies is terminated; (2) the limits of any of the required policies are reduced; (3) or the deductible or self-insured retention is increased. In the event of any cancellation or reduction in coverage or limits of any insurance, Sifi shall forthwith obtain and submit proof of substitute insurance.

**D. Builder's Risk (Course of Construction) Insurance.** SiFi may, if requested by the City, submit evidence of Builder's Risk insurance in the form of Course of Construction coverage. Such coverage shall name the City as a loss payee as their interest may appear.

If the project does not involve new or major reconstruction, at the option of the City, an Installation Floater may be acceptable. For such projects, a Property Installation Floater shall be obtained that provides for the improvement, remodel, modification, alteration, conversion or adjustment to existing buildings, structures, processes, machinery and equipment. The Property Installation Floater shall provide property damage coverage for any building, structure, machinery or equipment damaged, impaired, broken, or destroyed during the performance of the Work, including during transit, installation, and testing at the City's site.

**E. Acceptability of Insurers.** Insurance is to be placed with insurers authorized to conduct business in the state with a current A.M. Best rating of no less than A: VII, unless otherwise acceptable to the City.

**F. Waiver of Subrogation.** SiFi hereby agrees to waive rights of subrogation which any insurer of SiFi may acquire from Contractor by virtue of the payment of any loss. Contractor agrees to obtain any endorsement that may be necessary to affect this waiver of subrogation, but this provision applies regardless of whether or not the City has received a waiver of subrogation endorsement from the insurer. However, the Workers' Compensation policy shall be endorsed with a waiver of subrogation in favor of the City for all work performed by the Contractor, its employees, agents and subcontractors.

**G. Verification of Coverage.** SiFi shall furnish City with Certificates of Insurance including all required amendatory endorsements (or copies of the applicable policy language effecting coverage required by this clause) and a copy of the Declarations and Endorsement Page of the CGL policy listing all policy endorsements to City before the date of the start of Construction. However, failure to obtain the required documents prior to the work beginning shall not waive the SiFi's obligation to provide them. The City reserves the right to require complete, certified copies of all required insurance policies, including endorsements, required by these specifications, at any time.

**H. Contractor/Subcontractors.** SiFi shall require and verify that its Contractor and all subcontractors maintain insurance meeting all the requirements stated herein, and SiFi shall require its Contractor and all the subcontractors to list City as an additional insured on insurance required from subcontractors. For CGL coverage subcontractors shall provide coverage with a form at least as broad as CG 20 38 04 13.

**I. Special Risks or Circumstances.** City reserves the right to modify, at any time, these requirements, including limits, based on the nature of the risk, prior experience, insurer, coverage, or other circumstances.

## **SECTION 7**

### **7. Parties' Obligations.**

**7.1 City Cooperation.** City agrees to work in good faith with SiFi Networks as it applies to City for permits that may be required by City and in the event state or federal law or regulations prevents or precludes compliance with one or more provisions of this Agreement, or requires material modification of the Agreement, SiFi Networks shall promptly notify the City in writing of the anticipated duration of any delay caused thereby, and provided any such delay is not the fault of SiFi Networks, the parties agree SiFi Networks may seek an extension of this Agreement as approved by the City as may be reasonably necessary to comply with such new state and federal laws or regulations or the regulations of other governmental jurisdictions.

When reasonably able, City will provide SiFi Networks with a least thirty (30) days advance notice of any work in the Public Way that



requires the relocation of the System. In addition, where necessary, the City will provide SiFi Networks with an opportunity to access the System at the time of the excavation in the Public Way by others.

**7.2 Obligations of SiFi Networks.** In addition to all other duties and obligations contained elsewhere in this Agreement, SiFi Networks has the following duties and obligations:

- (i) Work closely with the SPOC of the City and relevant City departments with respect to the construction of the System.
- (ii) Comply with all requirements of City for permit and Public Way use applications, to the extent they may be required.
- (iii) Provide or arrange for the maintenance of the System and its functionality and operation.
- (iv) SiFi Networks and its contractors shall register with California DigAlert; and
- (v) SiFi Networks to relocate its facilities as needed for City capital improvement projects provided however that such City capital improvements project shall be limited to only those projects impacting, directly or indirectly, more than three hundred (300) contiguous feet of the System in the Public Way or the Sewer System (“Major Public Works Project”). Such Major Public Works Project(s) shall not include routine maintenance and repair that does not impact the System, including without limitation repair of pot holes, milling and repaving of roadways, and repair and replacement of sewer pipes and/or other aspects of the Sewer System. The City shall provide SiFi Networks with not less than sixty (60) days written notice of such Major Public Works Project, and SiFi shall temporarily relocate or cause to be relocated any of its impacted System within one hundred eighty (180) days of notification by the City at its sole cost and expense. In the event SiFi Networks determines in its sole discretion that such Major Public Works Project will have a material impact on the System such that it would be in the best interests of the Parties to temporarily or permanently relocate some or all of the System, the City agrees to provide all reasonable accommodations as reasonably requested by SiFi Networks and with no cost or charge by the City to SiFi Networks other than standard encroachment permit application and inspection fees, to allow and facilitate SiFi Networks the ability to temporarily or permanently relocate such portion of the System in or around the Public Way or Sewer System in a manner sufficient to maintain the operation of the System pursuant to the terms of the Agreement. SiFi Networks shall be responsible for the cost of any such temporary or permanent relocation of any portion of the System in connection with a Major Public Works Project.

(vi) SiFi Networks will endeavor to facilitate an introductory meeting between the City and Service Provider(s) who use the Network to provide services to residential and business, and further will advise any such Service Provider(s) that the City may require fees as required by law or regulation.

(vii) Provide response times in connection with repairs to be undertaken by SiFi Networks and/or contractors retained by SiFi Networks (as opposed to repairs to be undertaken by the City) and to establish the necessary personnel levels for required dispatch, repair, inventory, maintenance, and service of the System commencing no earlier than Substantial Completion as follows:

(i) Depending upon the type of fault or the method of identification, the City shall notify SiFi of a suspected fault and the generation of a service ticket. The City shall issue to SiFi one of the following service ticket(s), for which SiFi shall provide the corresponding response time:

(1) Standard Response (“STANDARD”)

a) Description: Construction in progress, capital improvement and other such projects impacting or potentially impacting the SiFi System and/or may impact the SiFi System, about which the City is aware of in advance. Examples of such projects include mill and fill projects, side relocations, road reclamation projects, and other similar projects, provided that any such STANDARD repair is subject to the then current California Dig Safe laws and regulations, and all other applicable laws and regulations.

b) SiFi’s contractor response time: On-site within forty-five (45) business days

(2) Non life threatening Emergency Response (“NON-LTER”)

a) Description: Curb and gutter projects, and utility (including telecommunications) projects requiring relocation, repair, or replacement that are impacted by the SiFi System and/or may impact the SiFi System, provided that any such NON-LTER repair is subject to the then current California Dig Safe laws and regulations, and all other applicable laws and regulations.

b) SiFi response time: On-site within seventy-two (72) hours

(3) Life Threatening Emergency Response (“LTER”)

a) Description: Break or hit in the main gas, main electric, main water, or main sewer line in the Public Way that has an immediate and direct impact to the traveling safety of the public in or around the Public Way, and wherein the City’s ability to implement repairs are impacted by the SiFi System and/or City repairs may impact the SiFi System.

b) SiFi’s contractor response time: On-site within four (4) hours

(ii) Upon receipt of a service ticket as set forth herein, SiFi will use reasonable efforts to dispatch a technician to the specified fault location as identified by the City. SiFi, working with the City, will then make the determination as to whether the technician will proceed with the repair(s) if possible, wait for arrival of a City contractor if necessary for investigation and/or repair of work, or leave the site.

## SECTION 8

### 8. **Breach; Rights and Remedies; Termination; Indemnification.**

8.1. **SiFi Networks Breach or Default.** In the event the City believes that SiFi Networks has not complied with or is otherwise in default with regard to any term of this Agreement, the City shall promptly notify SiFi Networks in writing with specific details regarding the exact nature of the alleged noncompliance or default (a “**City Breach Notice**”).

8.1.1 **SiFi Networks' Right to Cure or Respond.** SiFi Networks shall have thirty (30) calendar days from its receipt of a City Breach Notice (the “**Initial SiFi Cure Period**”) to:

(i) respond to the City, contesting the assertion of noncompliance or default and in such event the Parties shall use commercially reasonable efforts to promptly resolve such contest and to the extent the Parties are unable to resolve such contest within thirty (30) calendar days of SiFi Networks’ response, each Party shall be entitled to seek any and all rights and remedies available to it at law or in equity to resolve such contest; or

(ii) cure an actual default or noncompliance; provided, however, in the event that the default is curable but due to the nature of the default or noncompliance, such default or noncompliance cannot be cured within the Initial SiFi Cure Period, so long as SiFi Networks initiates reasonable steps to remedy and continuously and diligently uses all reasonable efforts to cure such default or noncompliance promptly and notifies the City of the steps being taken and the projected date that they will be completed, the Initial SiFi Cure Period shall be extended for a reasonable amount of time to permit such cure but not to exceed sixty (60) calendar days from SiFi Networks' receipt of a City Breach Notice (the "**Extended SiFi Cure Period**") and together with the Initial SiFi Cure Period, the "**SiFi Cure Period**").

#### 8.1.2 City Rights and Remedies.

(i) Except as provided in Sections 8.1.2(ii), (iii) and (iv) below which shall control in connection with the events described therein, if SiFi Networks fails to cure any actual noncompliance or default as provided in Section 8.1.1(ii) above within the SiFi Networks' Cure Period, the City may:

(a) seek specific performance of any provision of this Agreement which lends itself to such remedy as an alternative to money damages; or

(b) seek money damages from SiFi Networks; or

(c) in the event of the breach of, noncompliance with or default under any material term of this Agreement, terminate this Agreement and seek any and all rights and remedies available to it at law or in equity.

(ii) Subject to Section 10.2 below and provided that all applicable permits have been issued by the City, in the event SiFi Networks fails to commence Construction on or before the Construction Commencement Deadline in accordance with Section 4.1 above and subsequently fails to commence Construction within the SiFi Cure Period, the City may provide written notice to SiFi Networks of the City's intent to terminate this Agreement for such failure. SiFi Networks shall have an additional thirty (30) calendar day period after the SiFi Cure Period to commence Construction (the "**Additional SiFi Cure Period**"). If SiFi Networks fails to commence Construction by the last day of the Additional SiFi Cure Period, the City may terminate this Agreement by written notice to SiFi Networks and seek appropriate damages under this Agreement.

(iii) Subject to Section 10.2 below and provided that all applicable permits have been issued by the City, in the event SiFi Networks fails to complete construction of the System by the Construction Completion Deadline in accordance with Section 4.1 above and subsequently fails to complete said construction within the SiFi Cure Period, the City may provide written notice to SiFi Networks of the City's intent to terminate this Agreement for such failure. SiFi Networks shall have an additional thirty (30) calendar day period after the SiFi Cure Period to complete construction (the “**Additional SiFi Completion Cure Period**”). If SiFi Networks fails to complete said construction by the last day of the Additional SiFi Completion Cure Period, then SiFi Networks shall cease further construction but shall be allowed to operate the partially completed System.

(iv) Subject to Section 10.2 below and provided that all applicable permits have been issued by the City, at any time after Substantial Completion is achieved, in the event no internet, voice, data, or video service of any kind is capable of being provided over the System due solely to the acts or omissions of SiFi Networks for a period in excess of thirty (30) consecutive calendar days and SiFi Networks fails to restore such capability within the SiFi Cure Period, the City may provide written notice to SiFi Networks of the City's intent to terminate this Agreement. SiFi Networks shall have an additional thirty (30) calendar day period after the SiFi Cure Period to restore the capability of the System to provide Service (the “**Additional SiFi Service Cure Period**”). If SiFi Networks fails to restore the capability of the System to provide Service by the last day of the Additional SiFi Service Cure Period, then SiFi Networks shall cease further construction but shall be allowed to operate the partially completed System..

(v) Notwithstanding anything to the contrary in this Agreement, in no event shall the City be permitted to terminate this Agreement if the City is in breach of or default under this Agreement.

8.2 **City Breach or Default.** In the event SiFi Networks believes that the City has not complied with or is otherwise in default with regard to any term of this Agreement, SiFi Networks shall promptly notify the City in writing with specific details regarding the exact nature of the alleged noncompliance or default (a “**SiFi Breach Notice**”). The failure to promptly provide such notice, however, shall not act as a waiver of any rights and remedies of SiFi Networks hereunder unless and only to the extent that the City is materially prejudiced by such failure.

8.2.1 **City's Right to Cure or Respond.** The City shall have thirty (30) calendar days from its receipt of a SiFi Breach Notice (the “**City Cure Period**”); provided that the City Cure Period for a failure of the City to review permit applications and issue a permit(s) necessary to construct the System as

required under Sections 3.2 and 7.2.1(iv) (a “**Permit Issuance Breach**”) shall be seven (7) business days from its receipt of a SiFi Breach Notice) to:

(i) respond to SiFi Networks, contesting the assertion of noncompliance or default and in such event the Parties shall use commercially reasonable efforts to promptly resolve such contest and to the extent the Parties are unable to resolve such contest within thirty (30) calendar days of the City’s response, each Party shall be entitled to seek any and all rights and remedies available to it at law or in equity to resolve such contest; or

(ii) cure an actual default or noncompliance; provided, however, in the event that the default is curable but due to the nature of the default or noncompliance, such default or noncompliance cannot be cured within the City Cure Period, so long as the City initiates reasonable steps to remedy and continuously and diligently uses all reasonable efforts to cure such default or noncompliance promptly and notifies SiFi Networks of the steps being taken and the projected date that they will be completed, the City Cure Period shall be extended for a reasonable amount of time to permit such cure but not to exceed ninety (90) calendar days from the City’s receipt of a SiFi Breach Notice (the “**Extended City Cure Period**”); provided further, however, no Extended City Cure Period shall apply to a Permit Issuance Breach.

8.2.2 **SiFi Networks Rights and Remedies.** If the City fails to cure any actual noncompliance or default as provided in Section 8.2.1(ii) above within the applicable City Cure Period, SiFi Networks may:

(i) seek specific performance of any provision of this Agreement which lends itself to such remedy as an alternative to money damages; or

(ii) in the event of the breach of, noncompliance with or default under any material term of this Agreement, terminate this Agreement.

8.3 **Additional Rights to Terminate.**

8.3.1 At any time prior to commencing Construction or in the event the City fails to comply with the requirements of the Agreement, SiFi Networks shall have the immediate right, at its option, upon notice to the City to terminate this Agreement and shall be entitled to any and all other rights and remedies available to it at law or in equity, subject to the specific legal limitations SiFi Networks agreed to in this Agreement.

8.3.2 A Party shall have the right, at its option, upon notice to the other Party to terminate this Agreement if the other Party becomes (i)

insolvent, admits in writing its inability to pay its debts as they mature, makes an assignment for the benefit of creditors, or becomes subject to direct control of a trustee, receiver or similar authority, or (ii) subject to any bankruptcy or insolvency proceeding under federal, state or foreign statutes which is not rescinded or dismissed within thirty (30) calendar days.

#### 8.4 **Indemnification.**

SiFi Networks shall defend, indemnify and hold the City, its officials, officers, employees, volunteers and agents free and harmless from any and all claims, demands, causes of action, costs, expenses, liability, loss, damage or injury, in law or equity, to property or persons, including wrongful death, in any manner which actually or allegedly arise out of or are incident to any alleged intentional or negligent acts, errors, omissions, or willful misconduct of SiFi Networks, its officials, officers, employees, agents, contractors and subcontractors arising out of or in connection with the performance of the Services, the Project or this Agreement, including without limitation the payment of all attorney's fees and other related costs and expenses except where caused by the sole negligence, or willful misconduct of the City its officers, officials, employees and volunteers. SiFi Networks shall defend, at its own cost, expense and risk, any and all such aforesaid suits, actions or other legal proceedings of every kind that may be brought or instituted against the City, its directors, officials, officers, employees, agents or volunteers. SiFi Networks shall pay and satisfy any judgment, award or decree that may be rendered against the City or its directors, officials, officers, employees, agents or volunteers, in any such suit, action or other legal proceeding. SiFi Networks shall reimburse the City, its officials, officers, employees, agents and/or volunteers, for any and all legal expenses and costs incurred by each of them in connection therewith or in enforcing the indemnity herein provided. SiFi Networks' obligation to indemnify shall not be restricted to insurance proceeds, if any, received by the City its officials, officers, employees, agents or volunteers. It is understood that the duty of SiFi Networks to indemnify and hold harmless includes the duty to defend as set forth in Section 2778 of the California Civil Code. Acceptance by City of insurance certificates and endorsements required under this Agreement does not relieve SiFi Networks from liability under this indemnification and hold harmless clause. This indemnification and hold harmless clause shall apply to any damages or claims for damages whether or not such insurance policies shall have been determined to apply, and shall further survive the expiration or termination of this Agreement. By execution of this Agreement, SiFi Networks acknowledges and agrees to the provisions of this Section and that it is a material element of consideration.

8.5 **Limitation of Liability.** IN NO EVENT WILL EITHER PARTY BE LIABLE TO THE OTHER PARTY FOR ANY INDIRECT, CONSEQUENTIAL, SPECIAL, INCIDENTAL, RELIANCE, OR PUNITIVE DAMAGES OF ANY KIND

OR NATURE WHATSOEVER, INCLUDING ANY LOST SAVINGS OR HARM TO BUSINESS. EACH PARTY HEREBY RELEASES THE OTHER PARTY AND ITS AFFILIATES AND THEIR RESPECTIVE DIRECTORS, OFFICERS, MANAGERS, MEMBERS, EQUITY AND DEBT HOLDERS, PARTNERS, EMPLOYEES, CONTRACTORS AND REPRESENTATIVES AND THEIR HEIRS, SUCCESSORS AND ASSIGNS, FROM CLAIMS FOR ANY SUCH DAMAGES. Notwithstanding anything to the contrary contained in this Agreement, the provisions of this Section 8.5 will survive expiration or termination of this Agreement.

## **SECTION 9**

### **9. Disputes.**

9.1 For all claims, disputes or controversies arising out of, or in connection with, the breach, interpretation, application, or enforcement of this Agreement, or arising out of, or in connection with, the System which cannot be settled through negotiation, the Parties agree first to try in good faith to settle the matter by mediation in Sacramento County, California, prior to commencing litigation.

9.2 All claims, disputes or controversies arising out of, or in connection with, the breach, interpretation, application, or enforcement of this Agreement, or arising out of, or in connection with, the System, shall be decided in a court of law. The sole and exclusive venue for all claims, disputes or controversies arising out of, or in connection with, the breach, interpretation, application, or enforcement of this Agreement, or arising out of, or in connection with, the System, shall be in a state court in Sacramento County, California.

## **SECTION 10**

### **10. Miscellaneous Provisions**

10.1 **Assignment.** The provisions of this Agreement shall be binding upon and shall inure to the benefit of the Parties hereto and each of their respective successors and assigns as provided herein. The City shall not be permitted to assign, sell or transfer this Agreement, or its rights and duties under this Agreement, without the prior written consent of SiFi Networks, which consent shall not be unreasonably withheld, conditioned, or delayed. SiFi Networks shall have the right to assign, novate, sell, encumber, or transfer this Agreement and the System or any part thereof, without the consent of the City to SiFi's principal, affiliates, subsidiaries, subsidiaries of its principal or to any entity which acquires all or substantially all of the SiFi's assets in the market by reason of a merger, acquisition, or other business reorganization, provided such assignee, purchaser, or transferee has all appropriate licenses, to the extent SiFi's licenses, permits and approvals cannot be assigned or transferred, for the operation, management, and maintenance of the facilities contemplated herein and sufficient financial resources to fulfill all applicable terms and obligations under this Agreement. All other assignment, sale, or transfer by SiFi Networks of this Agreement shall require prior written consent of the City, which shall not be unreasonably withheld, delayed or conditioned. At least



thirty (30) calendar days prior to the effective date, or as soon as practicable, of any such assignment, sale or transfer, SiFi shall provide City with a fully executed copy of the assignment, sale or transfer document, signed by both Sifi and assignee/purchaser/transferee, indicating the assignee's/purchaser's/ transferee's assumption of all of SiFi's performance duties, liabilities and obligations under this Agreement. SiFi shall not be relieved of its performance duties, liabilities or obligations under this Agreement until City is in receipt, of a fully executed copy of the document evidencing such assignment of the obligations herein and the assignee's/purchaser's/transferee's assumption of SiFi's performance duties, liabilities, and obligations under this Agreement. Sifi may not otherwise assign this Agreement or the System without City's consent, City's consent not to be unreasonably withheld, conditioned, or delayed. Upon any such assignment, sale, transfer, or novation, SiFi Networks shall be released from all obligations and liabilities under this Agreement from and after the date of such assignment. SiFi Networks shall give the City thirty (30) days' advance notice of such assignment, sale, transfer or novation disclosing the identity of the Person to whom it has been assigned, transferred, sold or novated. The City agrees from time to time to promptly deliver (and in no event later than ten (10) days after request by SiFi Networks) to SiFi Networks an estoppel certificate addressed to the assignee, buyer or transferee designated by SiFi Networks, affirming for the benefit of such buyer, assignee or transferee the following (to the extent that the following are then true): the Agreement is in full force and effect; SiFi Networks is not in default thereunder; and such other matters as such assignee, buyer or transferee may reasonably request.

10.2 **Force Majeure.** Except as otherwise expressly set forth in this Agreement, SiFi Networks will not be held in default under, or in breach or noncompliance with, the provisions of this Agreement, nor suffer any enforcement or penalty relating to noncompliance or default (including termination, cancellation or revocation of this Agreement), where such noncompliance or alleged defaults occurred or were caused by any of the following events (each a "**Force Majeure Event**"): failure by the City to issue permit(s) required to construct the System or any part thereof to SiFi Networks or its contractor(s), failure by the City to comply with this Agreement, conduct by the City that materially interferes with SiFi Networks' ability to perform, labor strike, riot, war, earthquake, flood, hurricane, drought, tornado, unusually severe weather conditions, or other act of nature, labor disputes, failure of utility service necessary to construct the System, governmental, administrative or judicial order, or other event that is beyond SiFi Networks' reasonable control. Force Majeure Events also include work delays caused by waiting for utility providers to service or monitor their own utility infrastructure on which SiFi Networks' fiber optic cable and/or equipment may be deployed, as well as unavailability of materials and/or reasonably qualified labor to perform the work.

10.3 **Notice.** All notices and communications hereunder shall be in writing and shall be served upon the other party by hand delivery, nationally recognized overnight delivery service, United States certified mail, return receipt requested, electronic mail, or by facsimile with confirmed transmission and addressed as follows:

IF TO THE CITY:  
City of Folsom  
50 Natoma Street  
Folsom, CA 95630  
Attn: City Attorney

IF TO SIFI NETWORKS:  
SiFi Networks  
841 Apollo Street, Suite 470  
El Segundo, CA 90245  
**Email: NOTICES@SiFiNetworks.com**

or to such other address as such Party may hereafter specify for the purpose by notice to the other Party in the manner provided in this Section 10.3. All such notices, requests and other communications will be deemed received on the date of receipt if received prior to 5 p.m. on any business day in the place of receipt. Otherwise, any such notice, request or communication will be deemed not to have been received until the next succeeding business day in the place of receipt. Rejection or other refusal to accept or inability to deliver because of change of address of which no notice was given shall be deemed to be receipt of the notice.

10.4 **Entire Agreement.** This Agreement, including all Exhibits, embodies the entire understanding and agreement of the City and SiFi Networks with respect to the subject matter hereof. This Agreement supersedes all other agreements whether written, verbal, or otherwise between SiFi Networks and the City with respect to the subject of this Agreement.

10.5 **Severability.** If any term or provision of this Agreement is invalid, illegal or unenforceable in any jurisdiction, such invalidity, illegality or unenforceability shall not affect any other term or provision of this Agreement (which other terms and provisions shall remain in full force and effect) or invalidate or render unenforceable such term or provision in any other jurisdiction. Upon such determination that any term or other provision is invalid, illegal or unenforceable, the Parties hereto shall negotiate in good faith to modify this Agreement so as to effect the original intent of the Parties as closely as possible in a mutually acceptable manner in order that the transactions contemplated hereby be consummated as originally contemplated to the greatest extent possible.

10.6 **Governing Law.** This Agreement shall be deemed to be executed in the State of California and shall be governed in all respects, including validity, interpretation and effect, and construed in accordance with, the laws of the State of California as applicable to contracts entered into and performed entirely within the State, irrespective of conflict of laws principles.

10.7 **Modification.** This Agreement shall not be amended or otherwise modified, in whole or in part, except by an instrument, in writing, duly executed by the City and SiFi Networks. For the avoidance of doubt, this Agreement cannot be amended or modified orally or by course of conduct, and no executory agreement, oral agreement or course of conduct shall be effective to amend or modify this Agreement in whole or in part.

10.8 **No Third Party Beneficiaries.** Nothing in this Agreement or in any prior agreement is or was intended to confer third party beneficiary status on any party or Person not a party to this Agreement including a member of the public.

10.9 **No Waiver of Rights.** Nothing in this Agreement shall be construed as a waiver of any rights, substantive or procedural that SiFi Networks or the City may have under federal or state law unless such waiver is expressly stated herein.

10.10 **No Rights to the System.** The City expressly agrees that, except as expressly set forth in this Agreement, it does not and shall not claim at any time any interest or estate of any kind or extent whatsoever in the System, throughout the term of this Agreement. Except as provided in Section 8.1.2 (iii) and Section 8.1.2 (iv) above, SiFi Networks shall, at all times, retain title to and ownership of the System and all future extensions of the System, and shall have the right to lease the System or parts thereof to a provider of internet, data, voice, video and other services.

10.11 **Representations and Warranties.**

10.11.1 The City represents and warrants to SiFi Networks that: (a) it has full authority (including the authority required by any applicable law, ordinance, rule or regulation) to enter into and perform this Agreement and the execution, delivery and performance of this Agreement and the consummation of the transactions contemplated hereby and thereby are within the right, power and authority of the City and have been duly authorized by all necessary action on the part of City, (b) this Agreement has been duly executed and delivered by the City and it constitutes a legal, valid and binding agreement of the City enforceable against the City in accordance with its terms (except as enforcement may be limited by applicable bankruptcy, insolvency, reorganization, moratorium or similar laws affecting creditors' rights generally and by general principles of equity) and (c) the execution and delivery of this Agreement by the City and its performance hereunder and thereunder will not violate any law, ordinance, rule, or regulation applicable to the City.

10.11.2 SiFi Networks represents and warrants to the City that: (a) it has full authority to enter into and perform this Agreement and the execution, delivery and performance of this Agreement and the consummation of the transactions contemplated hereby and thereby are within the power and authority of SiFi Networks and have been duly authorized by all necessary action on the part of SiFi Networks, (b) this Agreement has been duly executed and delivered by SiFi Networks and it constitutes a legal, valid and binding agreement of SiFi

Networks enforceable against SiFi Networks in accordance with its terms (except as enforcement may be limited by applicable bankruptcy, insolvency, reorganization, moratorium or similar laws affecting creditors' rights generally and by general principles of equity) and (c) the execution and delivery of this Agreement by SiFi Networks and its performance hereunder and thereunder will not violate any law, rule, or regulation applicable to SiFi Networks.

10.11.3 OTHER THAN EXPLICIT REPRESENTATIONS AND WARRANTIES MADE BY SIFI TO CITY, SIFI NETWORKS MAKES NO REPRESENTATIONS OR WARRANTIES TO THE CITY OR ANY PERSON WITH RESPECT TO THE SYSTEM (OR THE COMPONENTS THEREOF) AND HEREBY DISCLAIMS ANY AND ALL EXPRESS, IMPLIED, OR STATUTORY WARRANTIES, INCLUDING, WITHOUT LIMITATION, ANY WARRANTIES OF MERCHANTABILITY, FITNESS FOR A PARTICULAR PURPOSE, AVAILABILITY, ERROR-FREE OR UNINTERRUPTED OPERATION, AND ANY WARRANTIES ARISING FROM A COURSE OF DEALING, COURSE OF PERFORMANCE, OR USAGE OF TRADE. TO THE EXTENT THAT SIFI NETWORKS MAY NOT AS A MATTER OF APPLICABLE LAW DISCLAIM ANY IMPLIED WARRANTY, THE SCOPE AND DURATION OF SUCH WARRANTY WILL BE THE MINIMUM PERMITTED UNDER SUCH LAW.

10.12 **Third Parties.** Nothing contained in this Agreement shall create a contractual relationship with, or a cause of action in favor of, a third party against either SiFi Networks or the City.

10.13 **No Partnership.** Nothing in this Agreement shall be construed to create a partnership, joint venture or agency relationship between the City and SiFi Networks or any other relationship other than a contractual relationship as expressly set forth in this Agreement. Neither Party shall in any manner act or indicate to any third party that is acting as the agent of the other Party. SiFi Networks shall at all times remain an independent contractor. Neither Party shall control or direct the day-to-day affairs of the other Party, or their mode or method of performing their respective obligations hereunder.

10.14 **Headings.** The headings and captions of this Agreement are solely for the convenience of the Parties and shall not be deemed to modify or vary any of the substantive terms thereof.

10.15 **Construction.** Each of the Parties acknowledge that each Party to this Agreement has been represented by counsel in connection with this Agreement. Legal or equitable principles that might require the construction of this Agreement or any provision hereof against the party drafting this Agreement shall not apply in any construction or interpretation of this Agreement and is expressly waived. In the event an ambiguity or question of intent or interpretation arises, this Agreement shall be construed as if drafted jointly by the parties and no presumption or burden of proof shall arise favoring or disfavoring any party by virtue of the authorship of any of the provisions of

this Agreement. The words “hereof”, “herein” and “hereunder” and words of like import used in this Agreement will refer to this Agreement as a whole and not to any particular provision of this Agreement. References to Articles, Sections, and clauses are to Articles, Sections and clauses of this Agreement unless otherwise specified. Any singular term in this Agreement will be deemed to include the plural, and any plural term the singular. Whenever the words “include”, “includes” or “including” are used in this Agreement, they will be deemed to be followed by the words “without limitation”, whether or not they are in fact followed by those words or words of like import. “Writing”, “written” and comparable terms refer to printing, typing and other means of reproducing words (including electronic media) in a visible form. References to any agreement or contract are to that agreement or contract as amended, modified or supplemented from time to time in accordance with the terms hereof and thereof. References to any Person include the successors and permitted assigns of that Person. References from or through any date mean, unless otherwise specified, from and including or through and including, respectively.

10.16 **Counterparts**. This Agreement may be signed in any number of counterparts, each of which will be deemed an original, with the same effect as if the signatures were upon the same instrument. A signed copy of this Agreement delivered by facsimile, e-mail or other means of electronic transmission (including PDF) shall be deemed to have the same legal effect as delivery of an original signed copy of this Agreement.

10.17 **Further Assurances**. Each Party agrees that it will execute and deliver such other documents and take such other action as may be reasonably requested by the other Party to effectuate the purposes and intention of this Agreement.

10.18 **No Waiver**. No provision of this Agreement may be waived unless such waiver is in writing and signed by the Party against whom the waiver is to be effective. No failure or delay by a Party in exercising any right, power or privilege hereunder shall operate as a waiver thereof, nor shall any single or partial exercise thereof preclude any other or further exercise thereof or the exercise of any right, power or privilege hereunder. No waiver of any breach of this Agreement shall be held to constitute a waiver of any other or subsequent breach.

[Signature page follows]

**IN WITNESS WHEREOF**, the Parties have caused this Fiber Networks Installation Agreement to be executed as of the day and year stated above.

**CITY OF FOLSOM,**  
a municipal corporation

\_\_\_\_\_  
\_\_\_\_\_  
City Manager

Dated: \_\_\_\_\_, 2022

Approved as to form:

\_\_\_\_\_  
\_\_\_\_\_  
City Attorney

**SIFI NETWORKS FOLSOM LLC,**  
a Delaware limited liability company

By: \_\_\_\_\_  
Its: \_\_\_\_\_

Dated: \_\_\_\_\_, 2022

EXHIBIT A  
SPECIFICATIONS, SHELTERS, CABINETS

# EXHIBIT

SPECIFICATIONS-SHELTERS-CABINETS  
FIBER CITY TYPICAL SPECIFICATIONS  
2/9/2021



Name:	Name:
Position:	Position:
Date:	Date:
Signature:	Signature:



# Table Of Contents

<u>Page Title</u>	<u>Page #</u>
Cover	1
Index	2
Ⓐ Roadway with a Curb Return	3
Ⓑ Roadway W/ Curb & Gutter Variant A	4
Ⓒ Roadway W/ Curb & Gutter Variant B	5
Ⓓ Roadway W/ Curb & Gutter Variant C	6
Ⓔ Roadway Street Crossing	7
Ⓕ 24x36x36 Standard Chamber/Inlet Protection	8
Ⓖ Typical Aggregation Shelter Plan/Elevation View	9
Ⓗ Typical Aggregation Shelter Plan Site Layout	10
Ⓘ Typical Cabinet Plan/Elevation View	11
Ⓝ Typical Cabinet Elevation View	12
Ⓚ 30x48x36 Cabinet & Aggregation Shelter	13
Ⓛ FAB Details	14
	15

# ROADWAY WITH A CURB RETURN

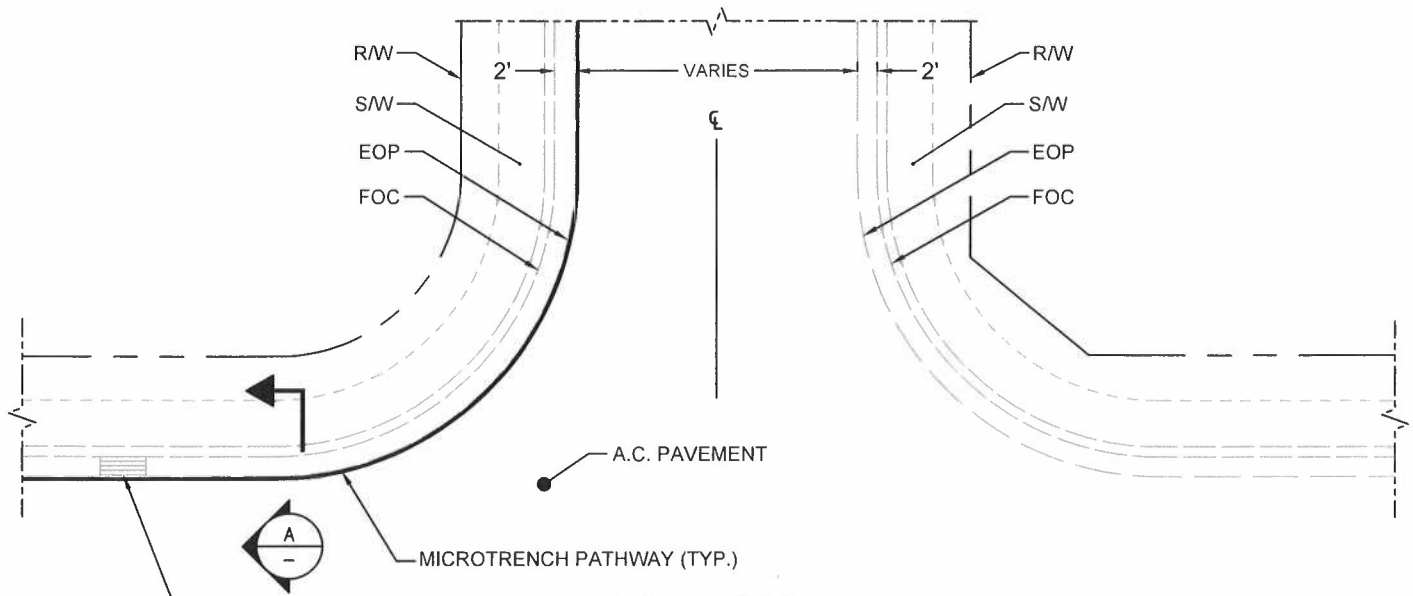

**PLAN VIEW**  
SCALE: NTS

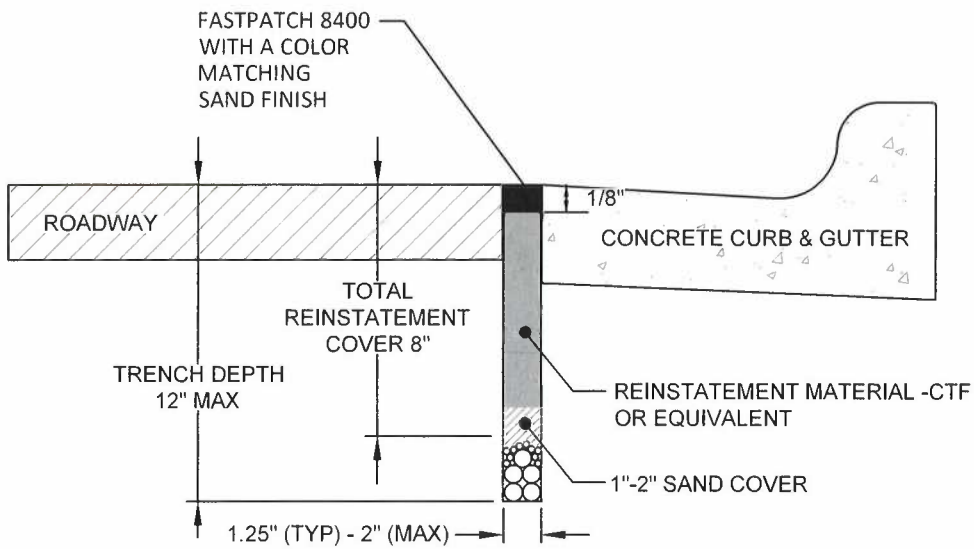

**SECTION VIEW A-A**



ROADWAY  
WITH A CURB  
RETURN

NO.	REVISIONS	BY	DATE
2	APPROVED RELEASE	RA	11/11/2020
STD DWG			
NOT TO SCALE		11/11/2020	0

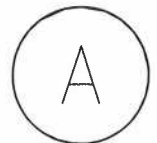

# ROADWAY WITH CURB & GUTTER - VARIANT A

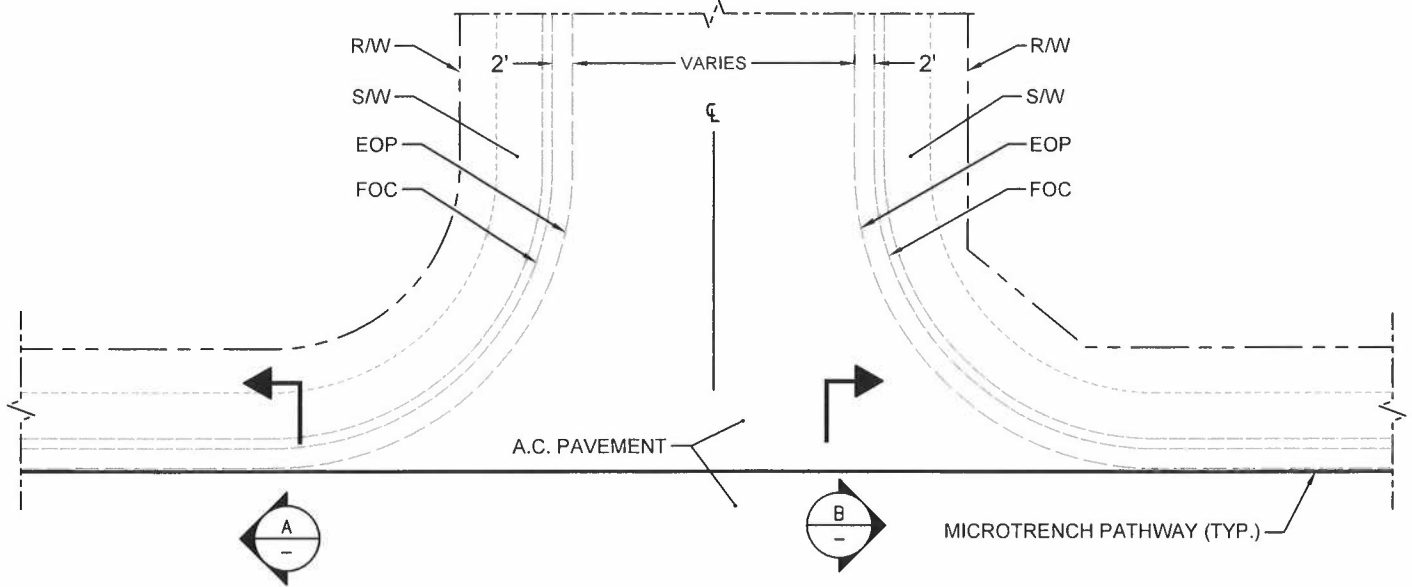

PLAN VIEW

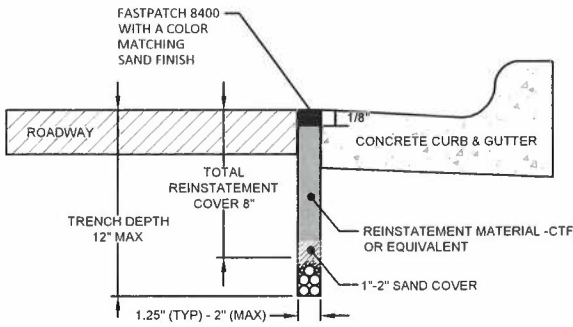

SECTION VIEW A-A

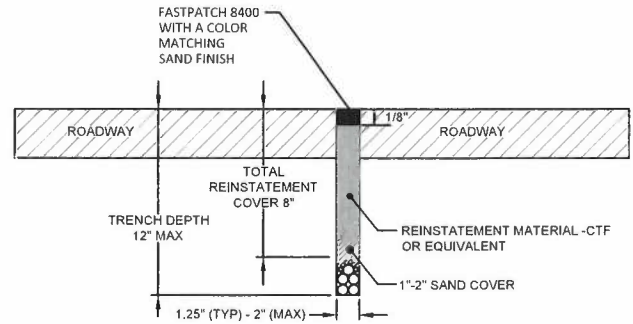

SECTION VIEW B-B



ROADWAY  
WITH A CURB  
RETURN VARIANT A

NO.	REVISIONS	BY	DATE
2	APPROVED RELEASE	RA	11/11/2020
STD DRAWING			
NOT TO SCALE		11/11/2020	0

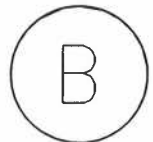

# ROADWAY WITH CURB AND GUTTER - VARIANT B

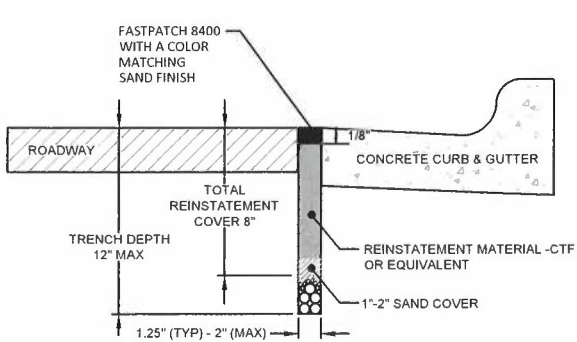
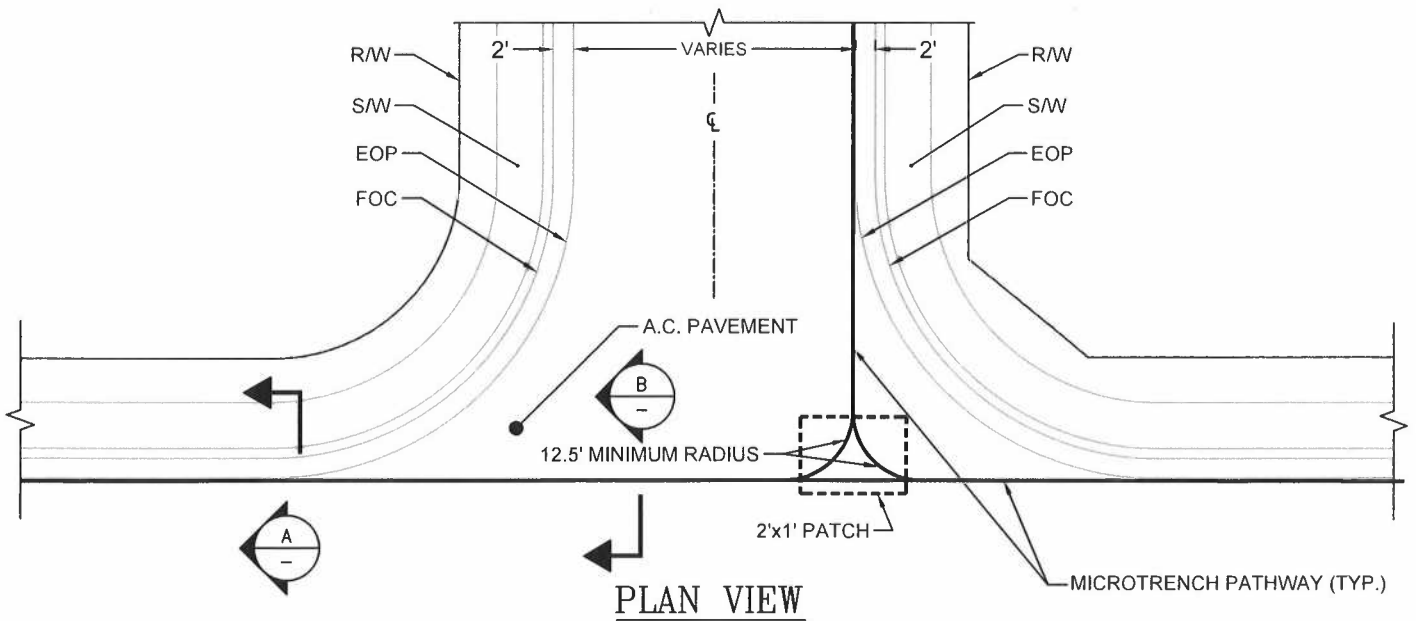

SECTION VIEW A-A

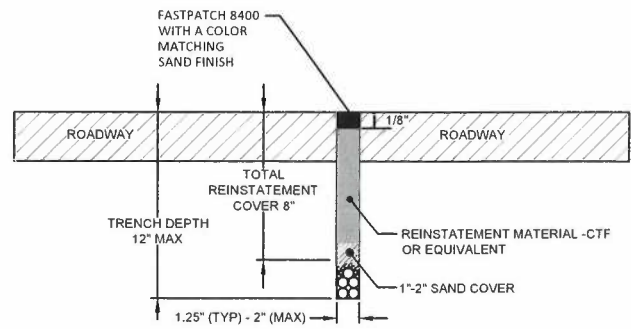

SECTION VIEW B-B



ROADWAY  
WITH A CURB  
RETURN VARIANT B

NO.	REVISIONS	BY	DATE
2	APPROVED RELEASE	RA	11/11/2020
STD DWG			
NOT TO SCALE		11/11/2020	0

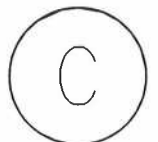

# ROADWAY WITH CURB AND GUTTER - VARIANT C

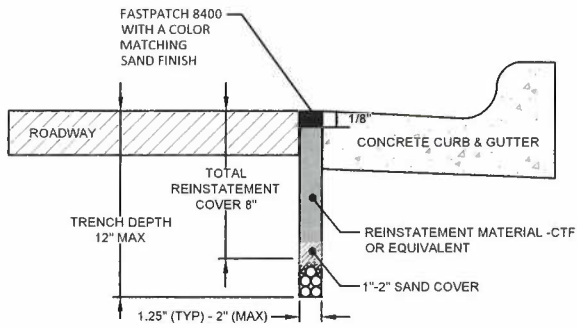
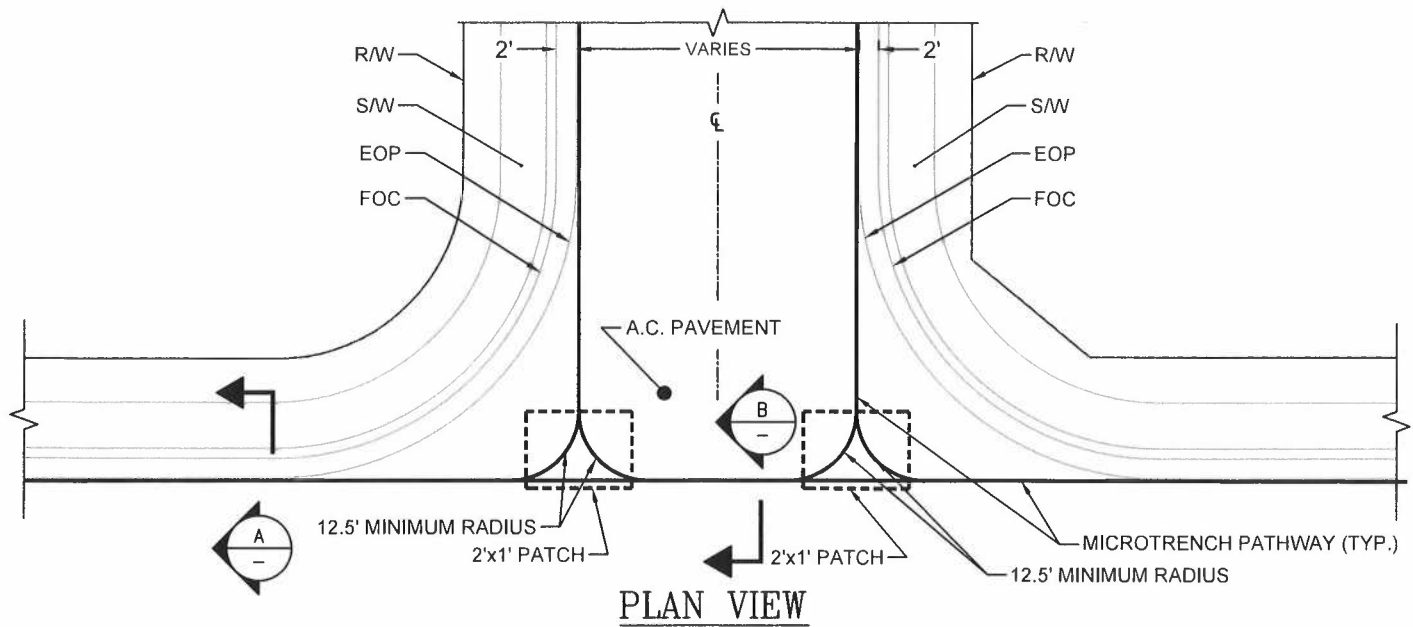

SECTION VIEW A-A

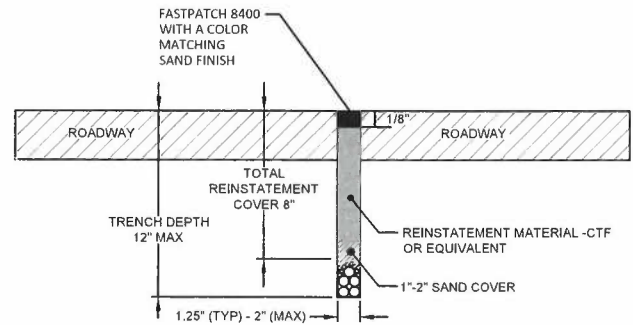

SECTION VIEW B-B



ROADWAY  
WITH A CURB  
RETURN VARIANT C

NO.	REVISIONS	BY	DATE
2	APPROVED RELEASE	RA	11/11/2020
STD DWG			
NOT TO SCALE		11/20/2020	0

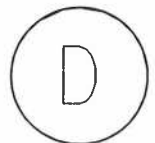

# ROADWAY CROSSING

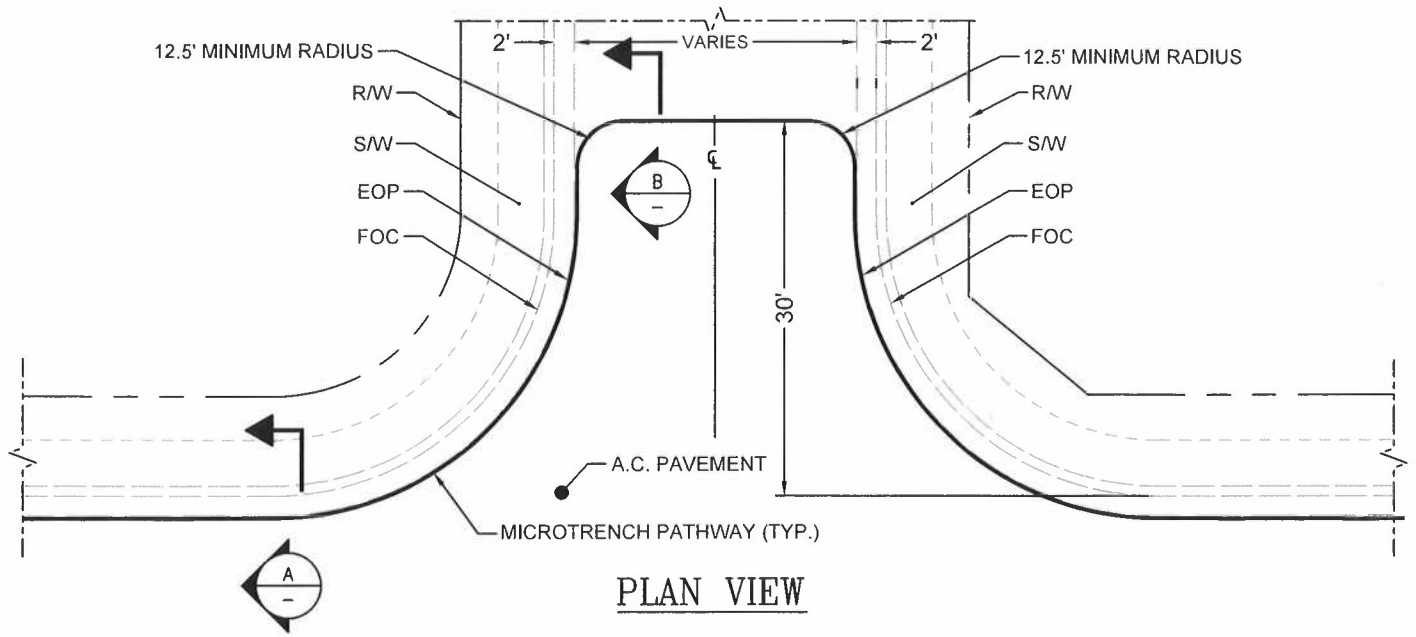

PLAN VIEW

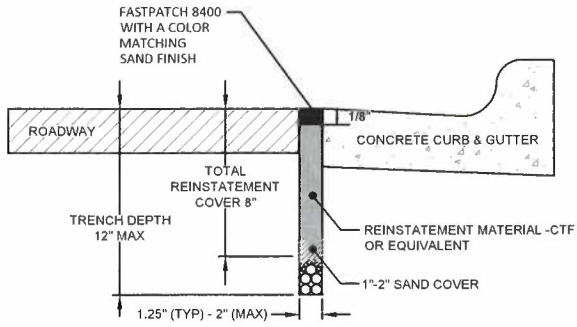

SECTION VIEW A-A

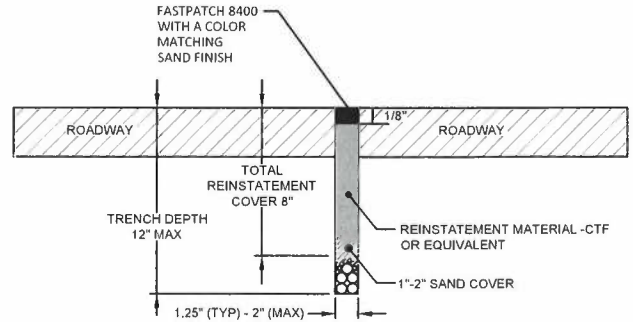

SECTION VIEW B-B



## ROADWAY CROSSING

NO.	REVISIONS	BY	DATE
2	APPROVED RELEASE	RA	11/11/2020
STD DWG			
NOT TO SCALE		11/11/2020	0



# STANDARD CHAMBER/INLET PROTECTION

**FEATURES:**

- 24" X 36" X 24" (open floor) (actual dimensions on drawing)
- CHAMBER – SHIELD X COVER- Tier 22 Load Rated (ANSI/SCTE 77: 2013)
- (2) Cover locking Auger bolts, Hex (9/16") or Penta (7/8") head with washer
- (2) Non-Seizing Fastening System, Field Replaceable
- (4) Embedded Composite Rack Support
- (2) Lifting slot equipped with stainless steel pin (slot is approximately 2 3/4" x 3/4")
- (2) Winterized Cable Drop slide (1 1/4" X 1 1/4")
- (1) Logo Disk

**WEIGHT & SHIPPING:**

- Cover Weight: 47 lbs
- Box Weight: 55 lbs
- Assembly Weight : 102 lbs

**PERFORMANCE TESTING:**

- ANSI/SCTE 77: 2013 - TIER 22 Rated (33,750 lbs)
- AS3996 – Class C
- EN124 Class B125
- ASTM C1028-07 & AS-4586 (Slip Resistance)
- 10,000 Hour Xenon-Arc Exposure (No fiber-bloom)
- ASTM D635-06 (Flammability)

Labels: Covered Lift Pin, SHIELD X Cover, Anti-Slip Tread Pattern, Logo, Embedded Racking (2 each side), CHAMBER.

Dimensions: 24" [610], 35 1/2" [903], 3" [75], 40 3/8" [1026], 28 3/4" [731].

Inside Dimensions		
Length	Width	Depth
34 3/8" [873]	22 3/4" [578]	21" [533]

EXCESS SOXX MATERIAL TO BE DRAWN IN AND TIED OFF TO 2X2 WOODEN STAKE (TYP.)

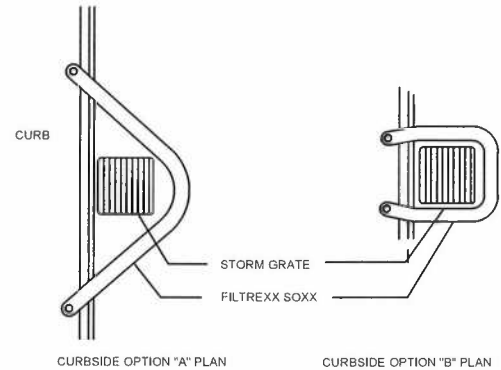
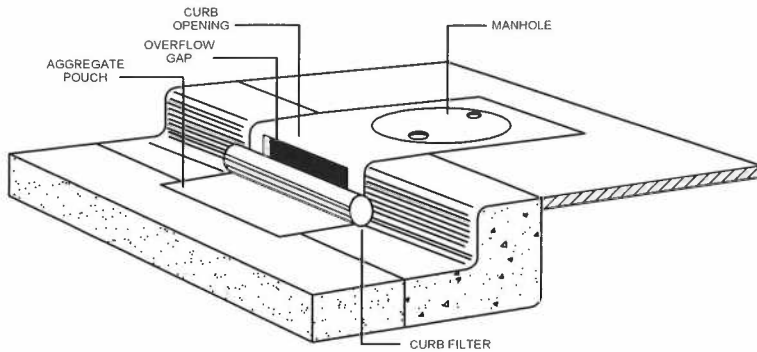

## INLET PROTECTION



## STANDARD CHAMBER/INLET PROTECTION

NO.	REVISIONS	BY	DATE
2	APPROVED RELEASE	RA	11/11/2020
STD DWG			
NOT TO SCALE		11/11/2020	0



# TYPICAL AGGREGATION SHELTER

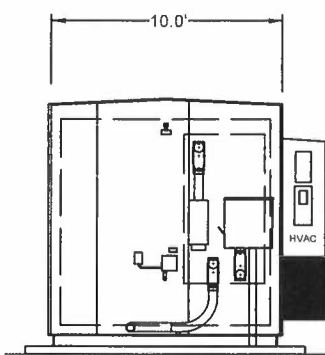
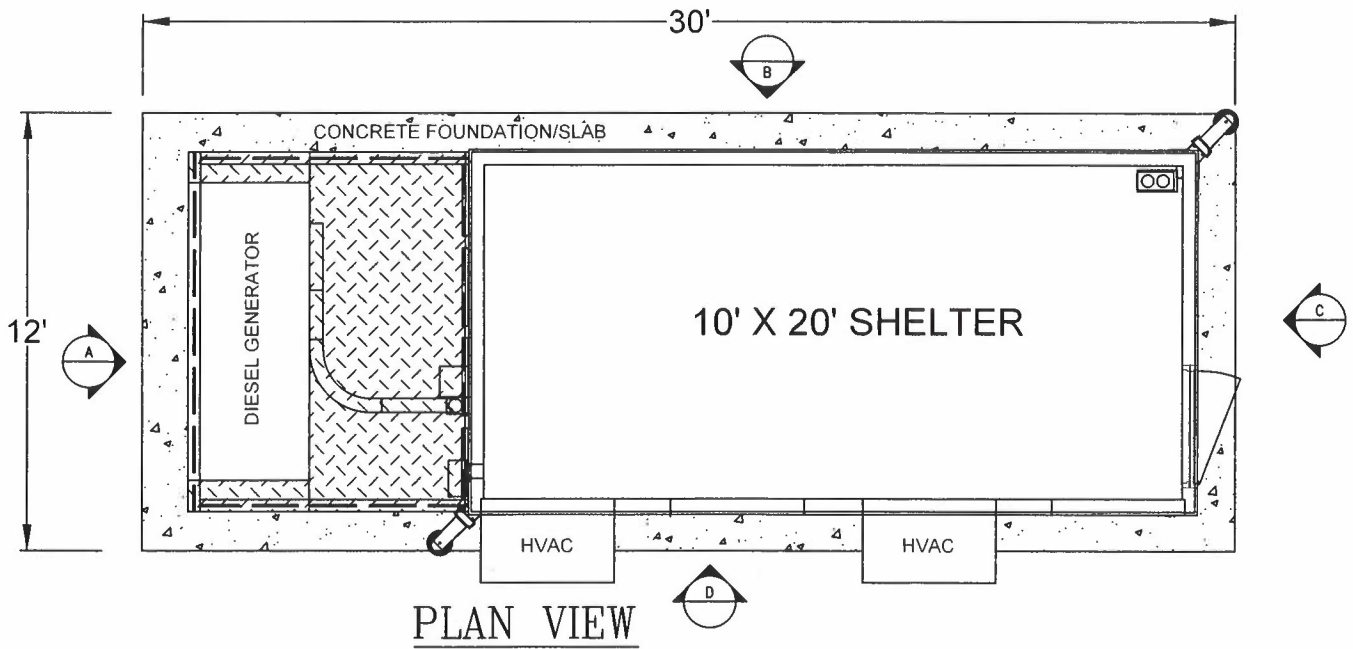

WALL "A"

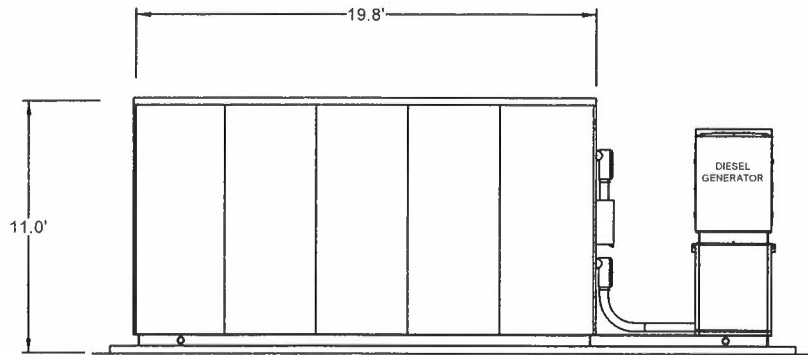

CONCRETE FOUNDATION/SLAB

WALL "B"

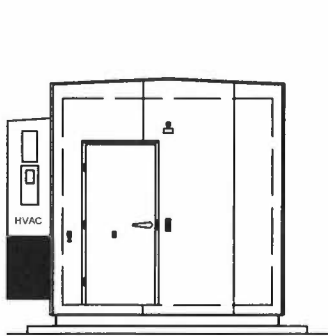

WALL "C"

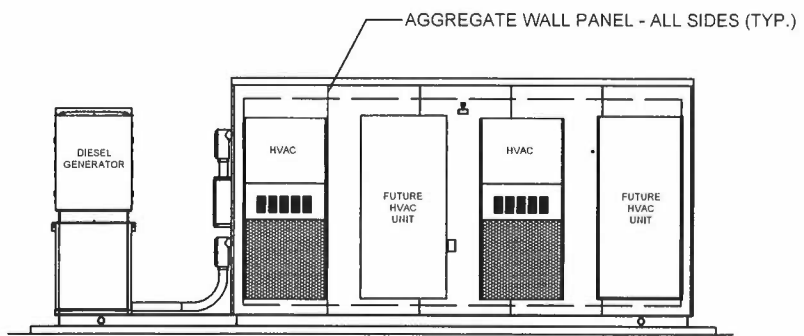

WALL "D"



TYPICAL  
AGGREGATION  
SHELTER

NO.	REVISIONS	BY	DATE
2	APPROVED RELEASE	RA	11/11/2020
STD DWG			
NOT TO SCALE		11/11/2020	0

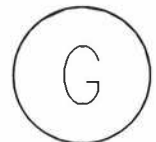



# TYPICAL AGGREGATION SHELTER

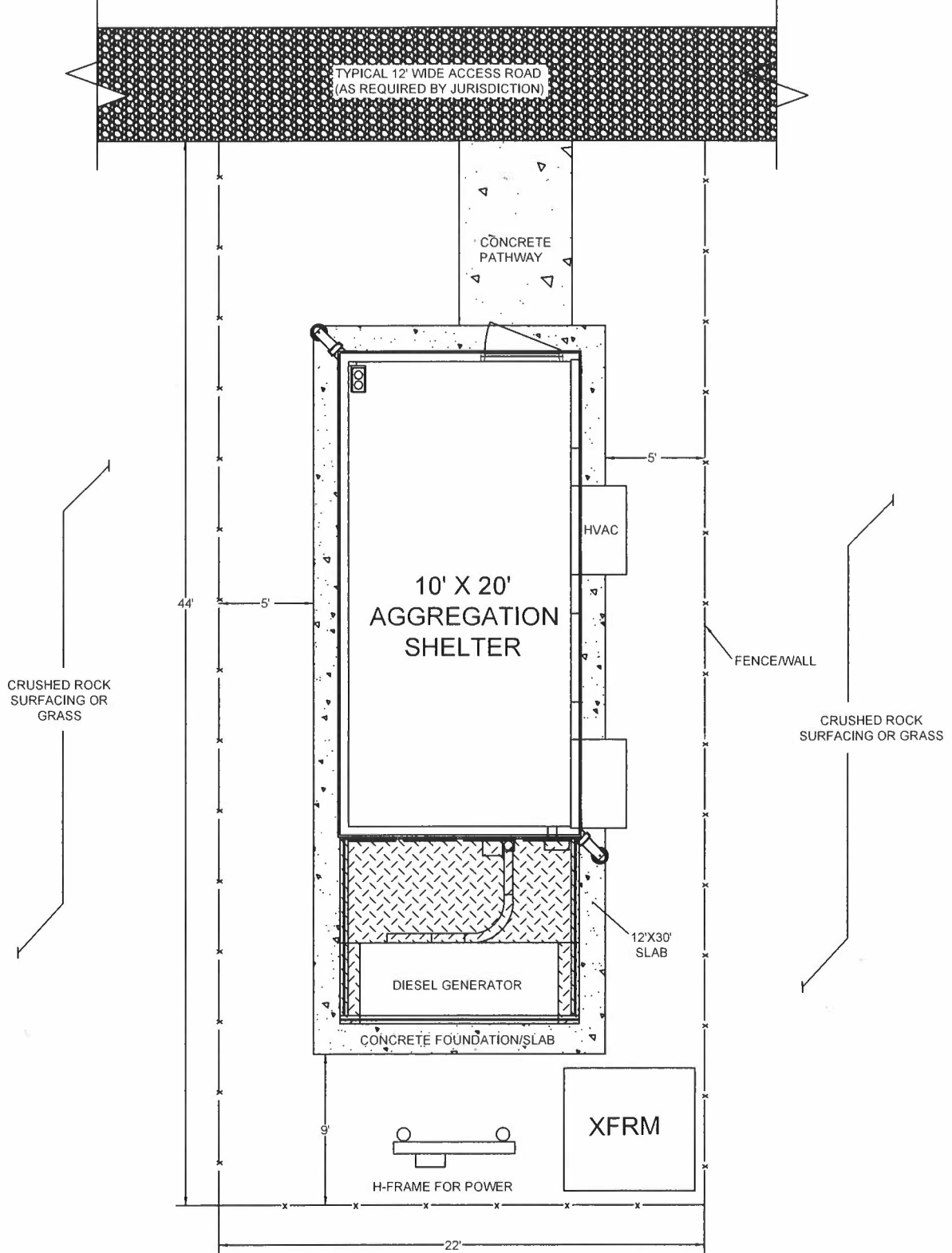

**SITE LAYOUT**



## TYPICAL AGGREGATION SHELTER

NO.	REVISIONS	BY	DATE
2	APPROVED RELEASE	RA	11/11/2020
STD DWG			
NOT TO SCALE		11/11/2020	0

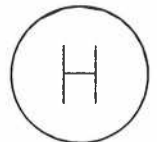

# TYPICAL CABINET DETAILS

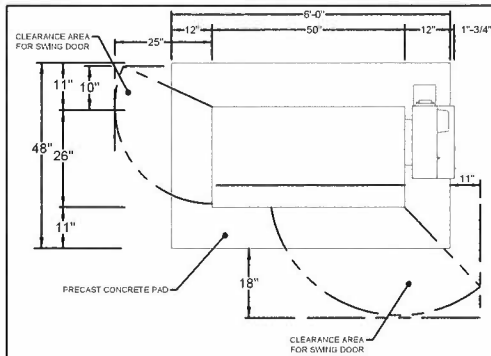
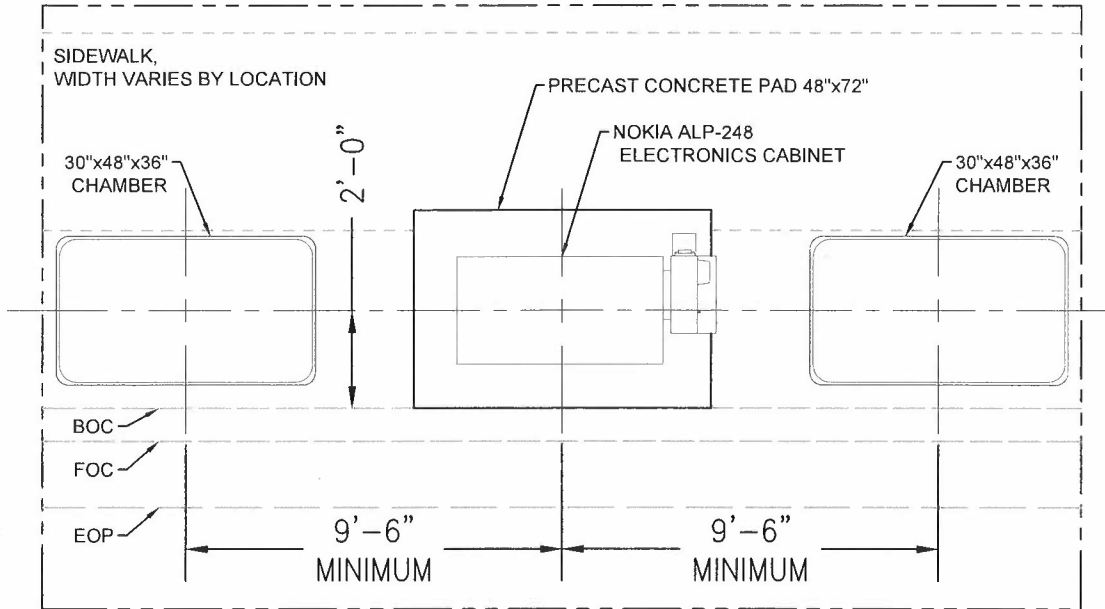

**TOP VIEW**

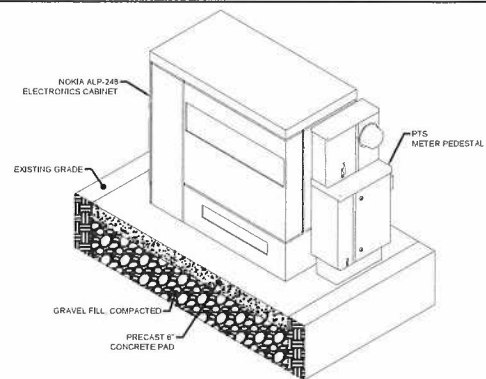

**BASE VIEW**

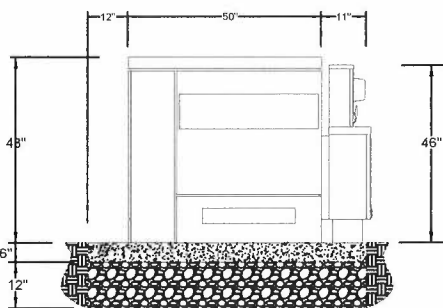

**SIDE VIEW**

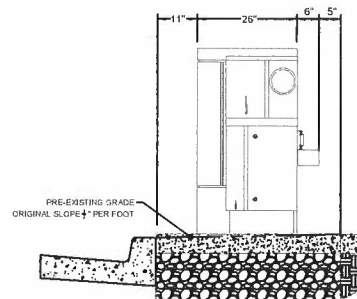

**PANEL VIEW**



## TYPICAL CABINET DETAILS

NO.	REVISIONS	BY	DATE
2	APPROVED RELEASE	RA	11/11/2020

STD DWG

NOT TO SCALE

11/11/2020

0

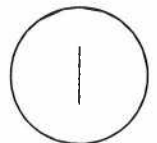

# TYPICAL CABINET DETAILS

MICRO TRENCH ENTRY NOTE:  
 • 4" DIAMETER PENETRATION  
 • 9" DOWN FROM TOP OF CHAMBER  
 • 6" IN FROM CORNER OF CHAMBER

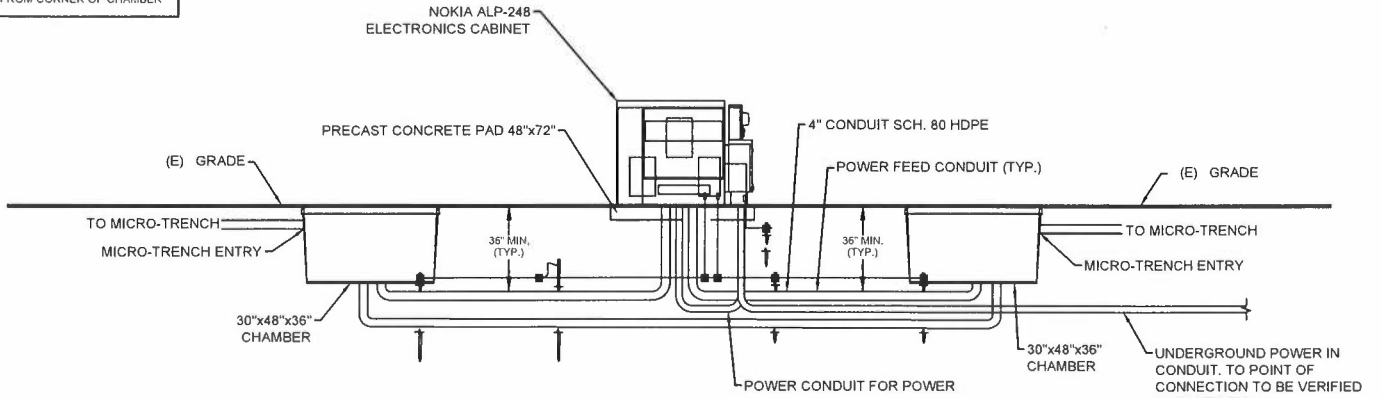

ELEVATION VIEW



## TYPICAL CABINET DETAILS

NO.	REVISIONS	BY	DATE
2	APPROVED RELEASE	RA	11/11/2020
STD DWG			
NOT TO SCALE		11/11/2020	0

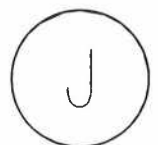

# CABINET & AGGREGATION SHELTER

**FEATURES:**

- 30" X 48" X 36" (open floor) (actual dimensions on drawing)
- CHAMBER – SHIELD X Split COVER- Tier 22 Load Rated (ANSI/SCTE 77: 2013)
- (4) Cover locking Auger bolts, Hex (9/16") or Penta (7/8") head with washer
- (4) Non-Seizing Fastening System, Field Replaceable
- (4) Embedded Composite Rack Support
- (1) Lifting slot equipped with stainless steel pin (slot is approximately 2 3/4"x3/4")
- (4) Winterized Cable Drop slide (1 1/2" X 1 1/2")
- (1) Galvanized Center Beam
- (2) Logo Disk

**WEIGHT & SHIPPING:**

- Cover Weight: 50 lbs (Per Half)
- Box Weight: 129 lbs
- Assembly Weight : 229 lbs

**PERFORMANCE TESTING:**

- ANSI/SCTE 77: 2013 - TIER 22 Rated (33,750 lbs)
- AS3996 – Class C
- EN124 Class B125
- ASTM C1028-07 & AS-4586 (Slip Resistance)
- 10,000 Hour Xenon-Arc Exposure (No fiber-bloom)
- ASTM D635-06 (Flammability)

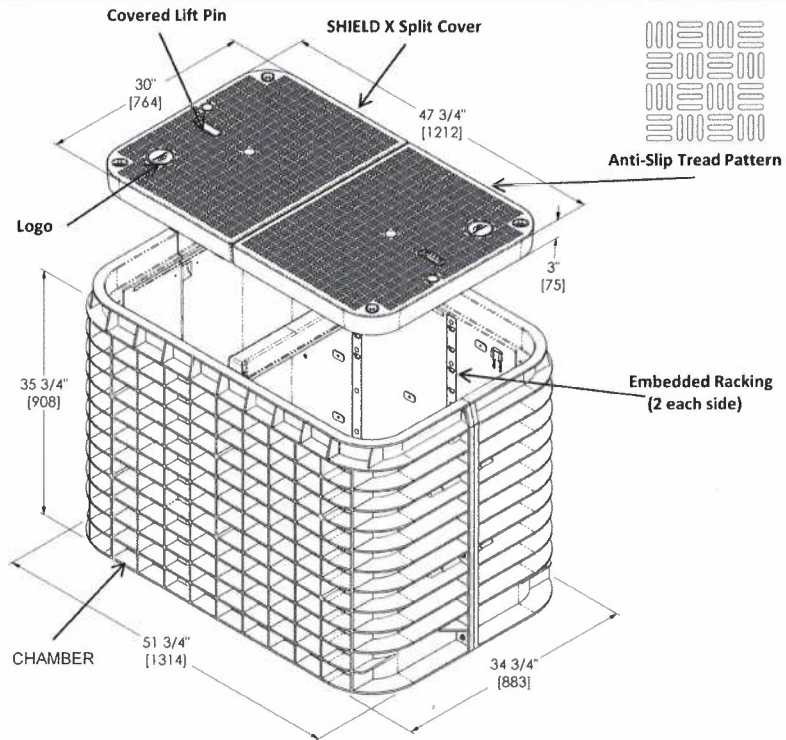

Inside Dimensions		
Length	Width	Depth
46 1/2" [1180]	28 3/4" [730]	32 3/4" [832]



## CABINET & AGGREGATION SHELTER

NO.	REVISIONS	BY	DATE
2	APPROVED RELEASE	RA	11/11/2020
STD DWG			
NOT TO SCALE		11/11/2020	0

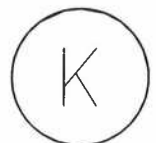

# FAB DETAILS

## Hardscape Lateral Typical With FAB Installed At ROW Obstruction

Lateral duct installation can either be installed by cutting a narrow micro trench from above, across the gutter pan curb & sidewalk & cold joint, or boring from the street beneath the gutter pan, curb & sidewalk. A neat 6" core cut at the edge of ROW 10" deep will allow FAB (Fiber Access Box) to be installed for ease of duct retrieval on service installs. This core cut would allow the FAB to be installed neatly with minimum reinstatement and would maintain the integrity and asphetic look of the sidewalk without the need to replace whole concrete sidewalk sections.

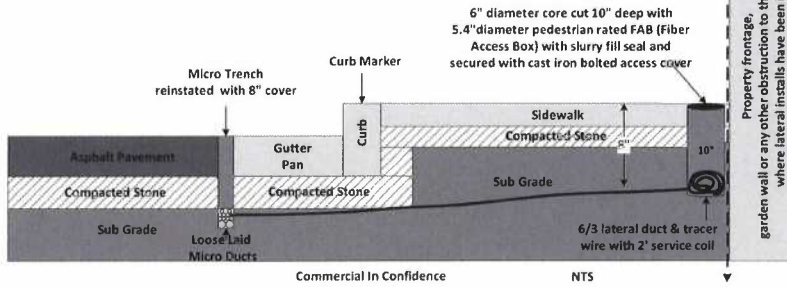
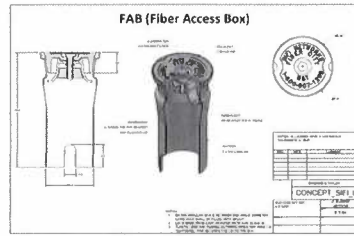

## FAB AT ROW

## Hardscape Lateral Typical With FAB Installed At Back Of Curb & Conduit Installed To ROW Obstruction

Lateral duct installation can either be installed by cutting a narrow micro trench from above, across the gutter pan curb & sidewalk & cold joint, or boring from the street beneath the gutter pan, curb. A neat 6" core cut at the back of curb 10" deep will allow FAB (Fiber Access Box) to be installed for ease of duct retrieval on service installs. To reach the ROW a slot cut would be made to just below the concrete base. A small conduit would then be installed to the ROW from the FAB with slow bend and cap for future use on drop installs when extending the lateral duct to the property through the pre installed conduit. This slot cut would be reinstated with and suitable fill in approval with DPW. This method would allow the FAB and conduit to be installed neatly with minimum reinstatement and would maintain the integrity and asphetic look of the sidewalk without the need to replace whole concrete sidewalk sections.

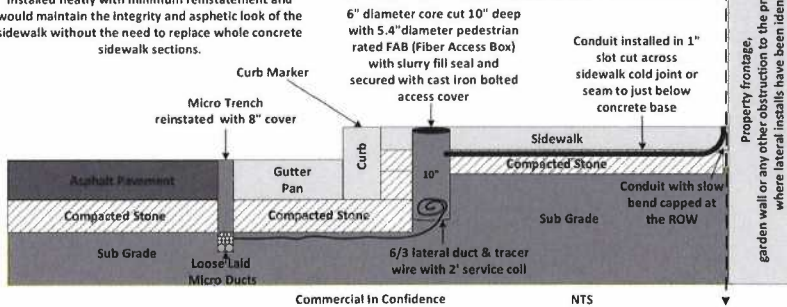
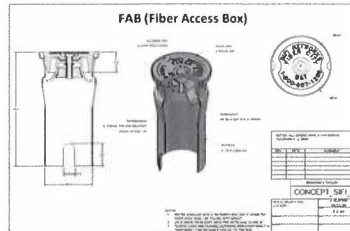

## FAB AT BOC



FAB DETAILS

NO.	REVISIONS	BY	DATE
2	APPROVED RELEASE	RA	11/11/2020
STD DWG			
NOT TO SCALE		11/11/2020	0



This page is intentionally left blank.