

- LEGEND:**
- = OPEN SPACE / DRAINAGE
 - = PROPOSED RIGHT-OF-WAY
 - = CONTOURS
 - = PHASING LIMITS
 - M.P.R. = M. PUBLIC RECORDS OF COMAL COUNTY, TEXAS
 - R.O.W. = RIGHT-OF-WAY
 - CL = CENTERLINE
 - = CROSS-HATCHED AREA IS A TEMPORARY EASEMENT FOR TURNAROUND PURPOSES UNTIL THE STREET IS EXTENDED TO THE EAST ON A RECORDED PLAT (OAK BEND SUBDIVISION PHASE II)

Exhibit C Master Plan

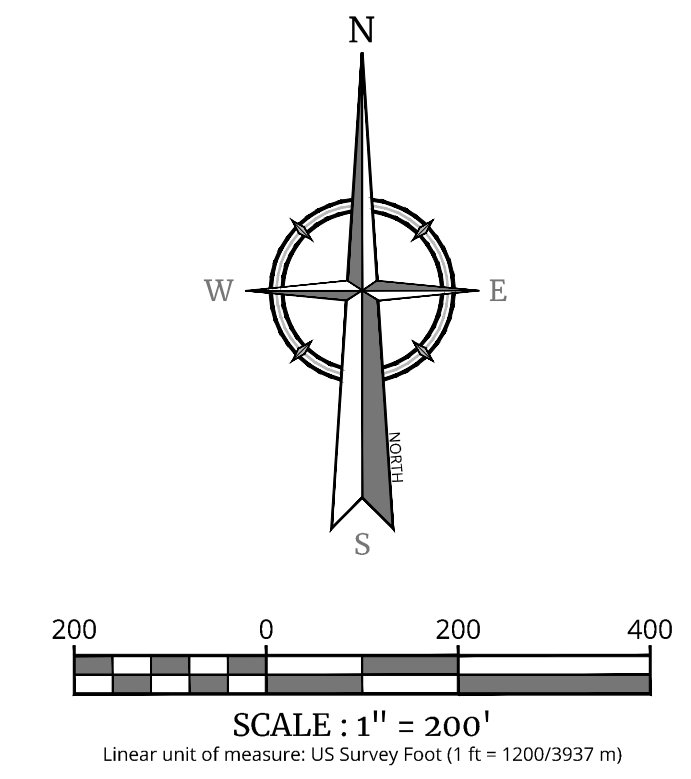

Line Table

Line #	Length	Direction
L1	227.42'	N00° 05' 12"W
L1	66.87'	S88° 12' 51"W
L2	201.98'	S44° 46' 20"W
L3	194.77'	S49° 50' 50"W
L4	194.82'	S54° 55' 00"W
L5	194.80'	S59° 50' 00"W
L6	231.70'	S65° 24' 25"W

PHASE	LAND USE	
	RESIDENTIAL (ACRES)	RESIDENTIAL (LOTS)
1	75.50	55
2	73.52	51
TOTAL	149.02	106

RESIDENTIAL LOTS = 106

Colliers
Engineering & Design
www.colliersengineering.com

Formerly Known as **KFW**
811 PROTECT YOURSELF
ALL STATES REQUIRE NOTIFICATION OF EXCAVATIONS, DESIGNERS, OR ANY PERSON PREPARING TO DISTURB THE EARTH'S SURFACE ANYWHERE IN ANY STATE
FOR STATE SPECIFIC DIRECT PHONE NUMBERS VISIT: WWW.CALL811.COM

REV	DATE	DRAWN BY	DESCRIPTION

--	--	--	--

OAK BEND SUBDIVISION

FAIR OAKS RANCH
COMAL COUNTY
TEXAS

Colliers SAN ANTONIO (KFW)
Engineering & Design 3421 Paesanos Parkway
San Antonio, TX 78231
Phone: 210.979.8444
COLLIERS ENGINEERING & DESIGN, INC.
TBS Form 11-1009
TBS Form 10194550

SCALE: AS SHOWN	DATE: APRIL 2024	DRAWN BY: -	CHECKED BY: -
PROJECT NUMBER: 758-07-03	DRAWING NAME: MDP7580703		

SHEET TITLE: MASTER CONCEPTUAL PLAN
SHEET NUMBER: 1 of 1

NOTE: DO NOT SCALE DRAWINGS FOR CONSTRUCTION.