

PROJECT: VALDEZ RESIDENCE

ADDRESS: 805 E Lemon Ave Eustis, FL

THE CONTRACTOR SHALL VERIFY ALL DIMENSIONS PRIOR TO FABRICATION OR START OF CONSTRUCTION. WRITTEN DIMENSIONS SHALL TAKE PRECEDENT OVER SCALED DIMENSIONS. ANY DEVIATIONS OR DISCREPANCIES SHALL BE PROMPTLY REPORTED TO THE ENGINEER OF RECORD. CONTRACTOR SHALL MAKE ALL EFFORTS TO PROTECT THE STRUCTURE, THE WORK PERSONS AND OTHER PEOPLE DURING CONSTRUCTION. THE CONTRACTOR SHALL SUPERVISE AND DIRECT THE WORK AND BE RESPONSIBLE FOR ALL CONSTRUCTION. THE CONTRACTOR SHALL COORDINATE ARCHITECTURAL, MECHANICAL AND ELECTRICAL DRAWINGS WITH STRUCTURAL DRAWINGS. THERE SHALL NOT BE ANY CHANGES TO THESE CONSTRUCTION DOCUMENTS DURING THE DEVELOPMENT OF SHOP DRAWINGS OR DURING CONSTRUCTION WITHOUT PRIOR WRITTEN APPROVAL BY THE ENGINEER OF RECORD.

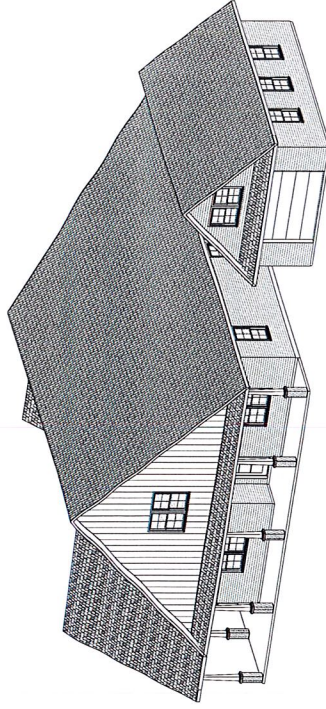

① PERSPECTIVE VIEW

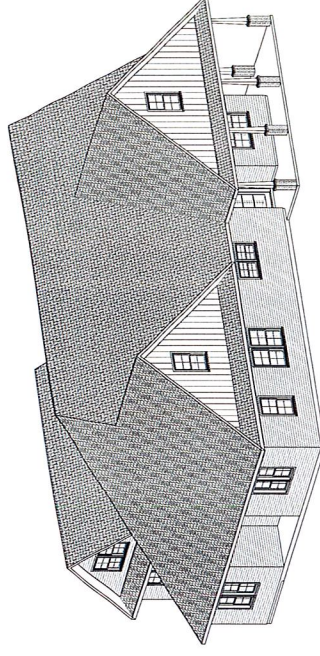

② PERSPECTIVE VIEW "B"



TOOLBOX
DRAFTING
TOOLBOXDRAFTING.COM

PROJECT NO.	085
DATE	11/30/22

PROJECT INFORMATION
Project
Address

COVER SHEET

PERMIT SET
SHEET
0-0

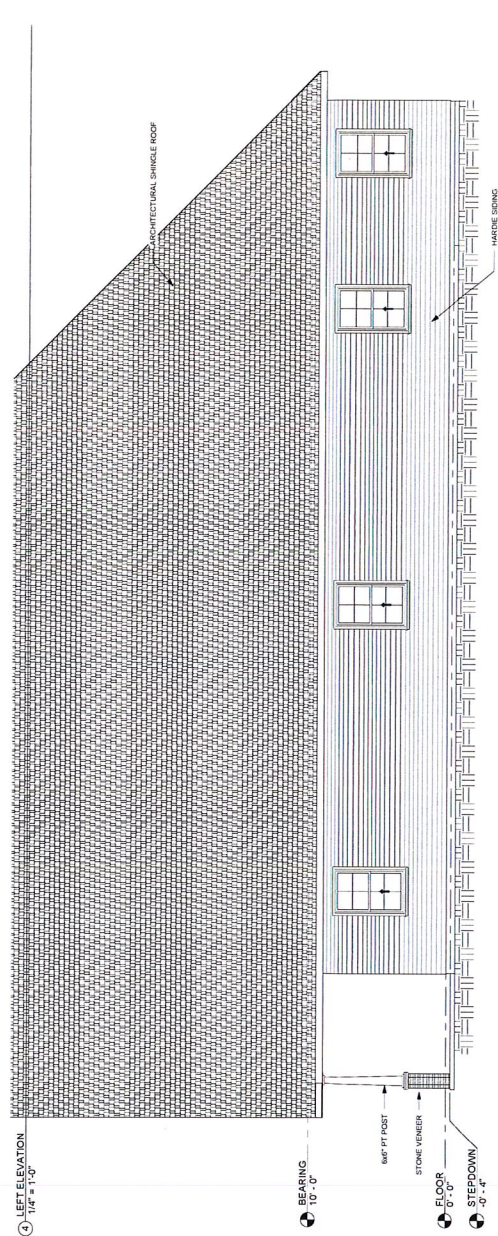
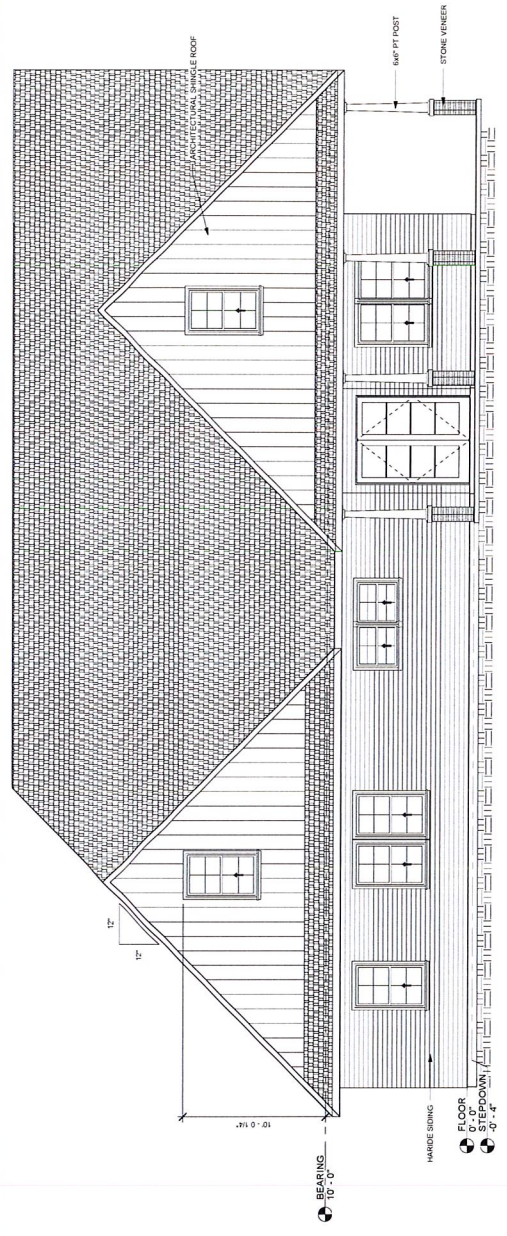

1 LEFT ELEVATION
 1/4" = 1'-0"

2 RIGHT ELEVATION
 1/4" = 1'-0"

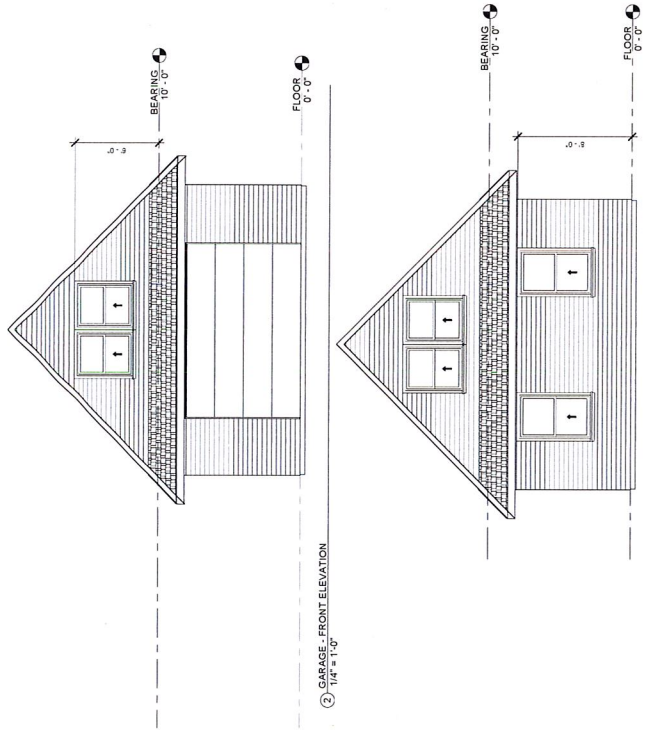

2 GARAGE - FRONT ELEVATION
1/4" = 1'-0"

3 GARAGE - REAR ELEVATION
1/4" = 1'-0"

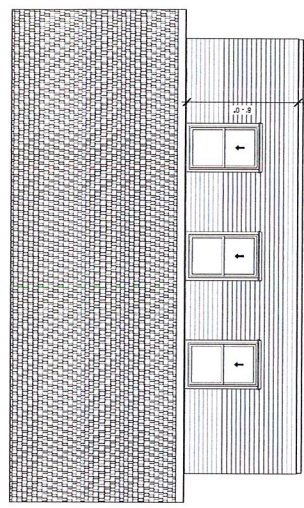

5 GARAGE - LEFT VIEW
1/4" = 1'-0"

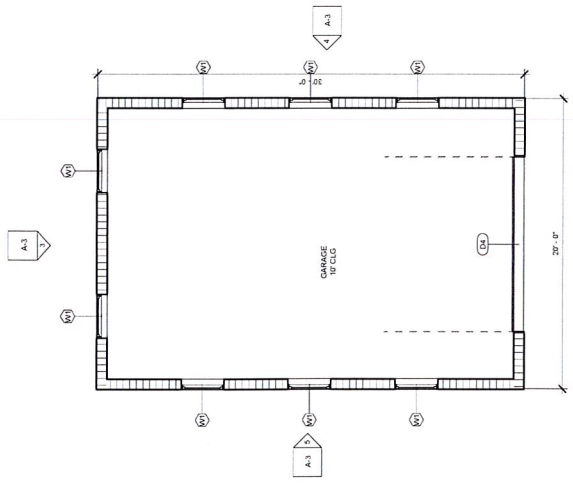

1 GARAGE FLOOR PLAN
1/4" = 1'-0"

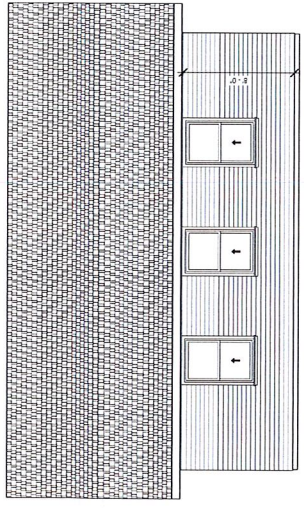

4 GARAGE - RIGHT VIEW
1/4" = 1'-0"

Window Schedule

Count	Type Mark	Family	Width	Height	Count	Type Mark	Family	Width	Height	Function
28	W1	Window-Single-Hung	3'-0"	5'-0"	1	D1	SINGLE INTERIOR	2'-6"	8'-0"	Interior
2	W2	Window-Single-Hung	3'-0"	3'-0"	11	D2	SINGLE INTERIOR	2'-8"	8'-0"	Interior
4	W15	Window-Single-Hung	3'-0"	4'-0"	2	D3	DOUBLE DOOR	4'-0"	8'-0"	Exterior
					2	D4	OVERHEAD GARAGE DOOR	12'-0"	8'-0"	Exterior
					2	D5	DOUBLE EXTERIOR FULL GLASS	8'-0"	8'-0"	Exterior
					1	D6	2 PANEL SLIDING GLASS DOOR	6'-0"	8'-0"	Interior
					1	D7	2 PANEL SLIDING GLASS DOOR	6'-0"	8'-0"	Interior

Door Schedule

Count	Type Mark	Family	Width	Height	Count	Type Mark	Family	Width	Height	Function
1	D1	SINGLE INTERIOR	2'-6"	8'-0"	1	D1	SINGLE INTERIOR	2'-6"	8'-0"	Interior
11	D2	SINGLE INTERIOR	2'-8"	8'-0"	11	D2	SINGLE INTERIOR	2'-8"	8'-0"	Interior
2	D3	DOUBLE DOOR	4'-0"	8'-0"	2	D3	DOUBLE DOOR	4'-0"	8'-0"	Exterior
2	D4	OVERHEAD GARAGE DOOR	12'-0"	8'-0"	2	D4	OVERHEAD GARAGE DOOR	12'-0"	8'-0"	Exterior
2	D5	DOUBLE EXTERIOR FULL GLASS	8'-0"	8'-0"	2	D5	DOUBLE EXTERIOR FULL GLASS	8'-0"	8'-0"	Exterior
1	D6	2 PANEL SLIDING GLASS DOOR	6'-0"	8'-0"	1	D6	2 PANEL SLIDING GLASS DOOR	6'-0"	8'-0"	Interior
1	D7	2 PANEL SLIDING GLASS DOOR	6'-0"	8'-0"	1	D7	2 PANEL SLIDING GLASS DOOR	6'-0"	8'-0"	Interior

AREA

Name	Area
FRONT PORCH	425 SF
LANAI	50 SF
GARAGE	501 SF
TOTAL	3388 SF

TOOLBOX DRAFTING SERVICES
TOOLBOXDRAFTING.COM

PROJECT NO. 085
DATE 10/0/22

PROJECT INFORMATION
Project: [Blank]
Address: [Blank]

FLOOR PLAN ELEVATIONS

PERMIT SET SHEET A-1

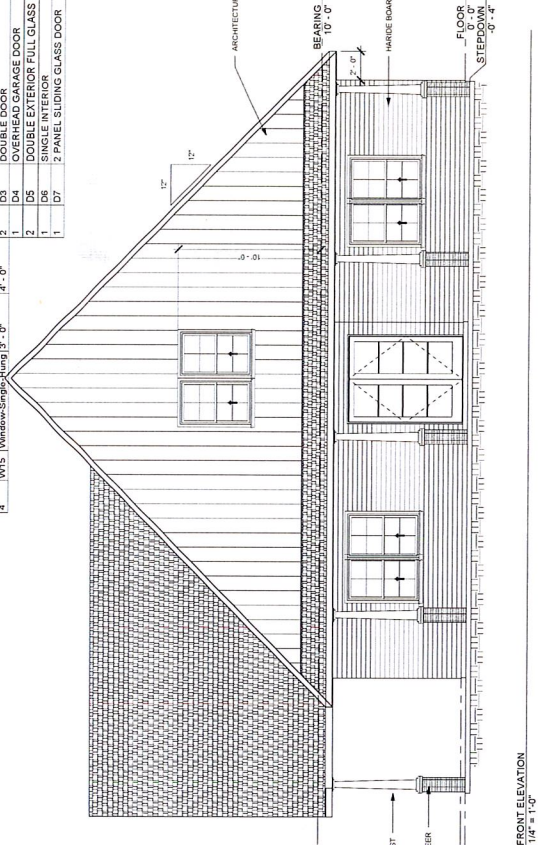

1 FRONT ELEVATION
1/4" = 1'-0"

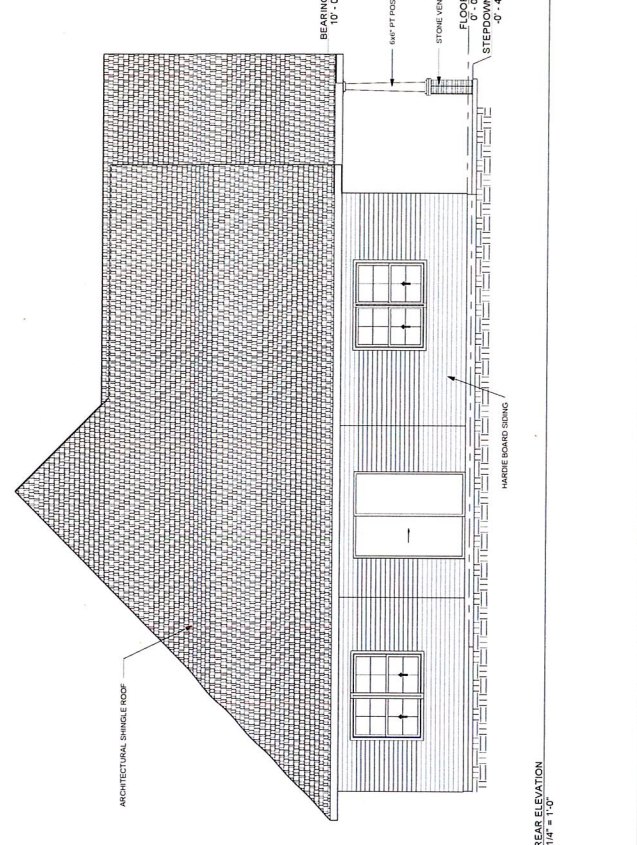

2 REAR ELEVATION
1/4" = 1'-0"

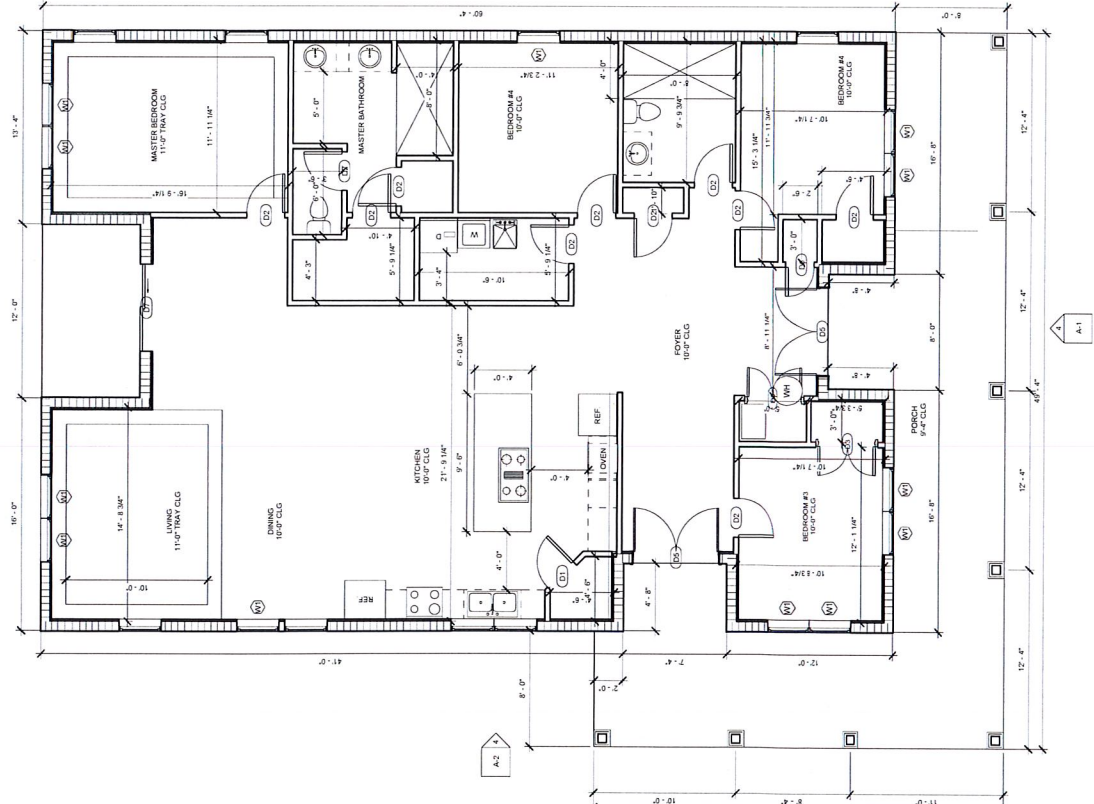

3 FLOOR PLAN
1/4" = 1'-0"

COLOR

SHINGLE - BROWN

HOUSE — BONE WHITE / BROWN

WINDOWS — BROWN