WATER AND SEWER STANDARDS



FOR THE
TOWN OF ELIZABETH

FINAL DRAFT

APRIL 2025

TABLE OF CONTENTS

	<u>PAGE</u>
SECTION 1 APPLICATION AND DEFINITIONS	1
1.1 APPLICABILITY	1
1.2 DEFINITIONS	1
SECTION 2 SYSTEM REQUIREMENTS, DESIGN AND SIZING	4
2.1 PURPOSE	4
2.2 OWNERSHIP OF FACILITIES	4
2.3 DRAWINGS	4
2.4 EASEMENTS	5
2.5 SEWER COLLECTION SYSTEM REQUIREMENTS	5
2.5.1 Specially Regulated Wastes.....	6
2.5.2 Prohibited Wastes	6
2.5.3 Pretreatment.....	7
2.5.4 Sump Pumps and Illegal Devices.....	8
2.5.5 Grease, Oil or Sand Interceptors.....	8
2.5.6 Swimming Pools	10
2.6 SEWER MAIN DESIGN / SIZING	10
2.7 WATER SYSTEM REQUIREMENTS	11
2.8 WATER DISTRIBUTION DESIGN / SIZING.....	11
2.9 INSPECTIONS.....	12
2.10 ACCEPTANCE CHECKLIST.....	12
SECTION 3 LOCAL SEWER AND WATER STANDARDS.....	14
3.1 PURPOSE	14
3.2 SANITARY SEWER MATERIALS	14
3.3 WATER MAIN MATERIALS	15
3.4 INSTALLATION	17
3.4.1 Sewer Installation.....	17
3.4.2 Manholes.....	17
3.4.3 Underdrains.....	18
3.4.4 Waterline Installation.....	18
3.4.5 Fire Hydrant Installation	19
3.4.6 Sewer and Water Main Pipe Bedding and Backfill	19
3.5 TESTING	23
3.5.1 Sanitary Sewer Line Testing.....	23
3.5.1.1 Pipeline Flushing.....	23
3.5.1.2 Alignment and Grade.....	24
3.5.1.3 Leakage Testing by Exfiltration.....	24
3.5.1.4 Leakage Testing by Infiltration.....	25
3.5.1.5 Low-Pressure Air Test	25
3.5.1.6 Deflection.....	27
3.5.2 Manholes.....	28

3.5.2.1	Visual Examination	28
3.5.2.2	Leakage Test	28
3.5.3	Television Inspection	29
3.5.4	Water Main Testing.....	29
3.5.5	Water Main Disinfection	30
SECTION 4 SERVICE LINE STANDARDS		31
4.1	GENERAL	31
4.2	OWNERSHIP AND MAINTENANCE.....	31
4.3	SERVICE CONNECTION	33
4.4	SEWER SERVICE SIZING.....	34
4.5	WATER SERVICE SIZING	34
4.6	SEWER SERVICE MATERIALS AND INSTALLATION	34
4.7	WATER SERVICE MATERIALS.....	35
4.8	WATER SERVICE INSTALLATION	36
4.9	DOCUMENTATION	36

SECTION 5 BACKFLOW PREVENTION AND CROSS-CONNECTION CONTROL

STANDARD DETAILS

GENERAL

- G1 - STANDARD APPROVAL BLOCK
- G2 - TYPICAL WATER AND SEWER STREET PLAN
- G3 - SEWER AND WATER LINE CROSSING
- G4 - CONCRETE ENCASEMENT
- G5 - SURFACE MARKER
- G6 - BORE CASING
- G7 - HARNESS LUGS – BORE CASING

SEWER SYSTEM

- S1 - SEWER PIPE TRENCH
- S2 - STANDARD MANHOLE
- S3 - DROP MANHOLE
- S4 - FLAT TOP MANHOLES
- S5 - CAST-IN-PLACE MANHOLE BASES
- S6 - GREASE INTERCEPTOR
- S7 - SAND & OIL INTERCEPTOR

WATER SYSTEM

- W1 - WATER PIPE TRENCH
- W2 - HORIZONTAL THRUST BLOCKS
- W3 - VERTICAL THRUST BLOCKS

- W4 - MECHANICAL THRUST RESTRAINT**
- W5 - TRACER WIRE**
- W6 - BURIED VALVES**
- W7 - FIRE HYDRANT**
- W8 - BLOW-OFF**
- W9 - AIR RELIEF VALVE**

SERVICE LINES

- L1 - TYPICAL RESIDENTIAL SEWER SERVICE**
- L2 - SEWER SERVICE WYE CONNECTION**
- L3 - SEWER SERVICE LINE CLEANOUT**
- L4 - TYPICAL NEW SINGLE FAMILY DETACHED
RESIDENTIAL WATER SERVICE**

SECTION 1
APPLICABILITY AND DEFINITIONS

SECTION 1

APPLICATION AND DEFINITIONS

1.1 APPLICABILITY

These standards are to be applied in conjunction with the other administrative and procedural requirements of the Town of Elizabeth.

1.2 DEFINITIONS

Unless the context specifically indicates otherwise, the meaning of terms used herein shall be as follows (In addition, see Section 5 for backflow prevention specific definitions)

Acceptance shall mean formal notification by the Town to the Applicant that all the requirements of the "Checklist" have been met.

Actual Cost shall mean all direct costs applicable to the construction of a given facility, including surveys, preliminary and design engineering, construction, inspection, administrative, regulatory agency fees, bond fees, all required easements and/or rights-of-way, plan approval fees, "as-built" drawings, attorneys' fees, and other costs necessary for completion.

Applicant shall mean the person(s), firm, joint venture, partnership or corporation which is requesting service from the Town. In this document, the words "applicant" and "developer" have been used interchangeably.

Board and Board of Trustees shall mean the governing body of the Town of Elizabeth.

B.O.D. (Denoting 5-Day, 20 degrees centigrade Biochemical Oxygen Demand) shall mean the amount of oxygen which is utilized in the aerobic decomposition of Sewage under laboratory procedures in accordance with the current "Standard Methods for the Examination of Water and Wastewater" published by the American Public Health Association, the American Water Works Association and the Water Environment Federation.

Contractor shall mean the entity working on behalf of the developer to construct utilities or other physical improvements.

CDPHE shall mean the Colorado Department of Public and Health and Environment.

Cross-Connection means any physical arrangement whereby a public water supply is connected, directly or indirectly, with any other water supply system, sewer, drain, conduit, pool, storage reservoir, plumbing fixture or other device which contains, or may contain, contaminated water, sewage or other waste or liquid of unknown or unsafe quality which may be capable of imparting contamination to the public water supply as a

result of backflow. Bypass arrangements, jumper connections, removable sections, swivel or changeover devices, and other temporary or permanent devices through or because of which backflow could occur are considered to be cross connections.

Customer shall mean any person, company, corporation or governmental authority or agency authorized to use the public water or sewer systems under a permit issued or otherwise authorized by the Board of Trustees or the Town Administrator.

Developer shall mean the person(s), firm, joint venture, partnership or corporation which is the owner or operator of land and which seeks to have the land served by the Town.

Engineer shall mean the engineering firm, or duly authorized representative (engineer), designated by the Town to act on its behalf in all engineering and related matters. This item includes an Inspector employed by the Engineer.

Engineer of Record shall mean the Professional Engineer, registered with the State of Colorado, who is responsible for the design of utilities or other improvements on behalf of the Developer.

EQR This is an abbreviation for Equivalent Residential Unit which is an average single-family detached residence or the equivalent, from a systems demand standpoint.

Inspector shall mean the Manager, Superintendent, Engineer, agent, officers, employees of the Town or other person so designated by the Manager to perform inspections pursuant to these Standards or other Rules and Regulations of the Town.

Local Facilities are those facilities generally designed primarily to serve individual subdivisions or plats. Examples are: water distribution systems, collector sewer lines and storm drainage collection systems.

Manager shall mean Manager of the Town, Public Works Director or, the Manager's duly authorized agent.

Owner shall mean the land's record title holder or lessee with planning powers.

Oversize Costs this item is applicable to part of the construction costs of a water distribution line or sewer main to be installed within, or for, a subdivision; but which the Town has also assigned a transmission function which results in the need for a larger pipeline. Oversize costs are the difference between the actual costs of the size line required by the Town and the size required by the Developer; however, for purposes of determining oversize, the minimum size shall be assumed to be 12-inch diameter for water and 10-inch diameter for sewer. Engineering and inspection costs are not included, only construction costs. The additional cost for the oversize may be negotiated between the Town and the Developer.

PRV shall mean pressure reducing valve.

PVC shall mean poly vinyl chloride.

Permit shall mean written permission of the Board of Trustees authorizing connection to water or a sewer main of the Town granting applicant a license to use the system or to receive service from the system owned, operated or served by the Town.

Person shall mean any individual, firm, company, association, society, corporation or group.

Raw Water shall mean water that has not been treated.

Regional Facilities shall mean those facilities generally serving the Town's service areas as a whole. Examples are: water sources, water treatment plants, wastewater treatment plants, lift stations, tanks, and water transmission lines or trunk sewer mains.

Sewage shall mean any liquid waste containing animal or vegetable matter in suspension or solution from residences, commercial buildings, institutions, and industrial establishments.

Sewer or Sewer Main shall mean a Town-owned sewer pipeline, carrying sanitary sewage or approved industrial wastes only, and shall be installed in a public street or easement.

Sewer Service Line shall mean the privately owned sewer line extending from the building to the sewer main and shall include the tap onto the sewer main.

Shall is mandatory; "May" is permissive.

Town shall mean the Town of Elizabeth or the Board of Trustees of the Town.

Water Main shall mean a Town-owned water pipeline, carrying potable water only and shall be installed in a public street or easement.

Water Service Line shall mean the water line extending from the water main to the Customer's building, and shall include the tap on the main, corporation cock, curb stop and box and meter installation (see Section 4 for ownership responsibilities).

SECTION 2
SYSTEM REQUIREMENTS, DESIGN AND SIZING

SECTION 2

SYSTEM REQUIREMENTS, DESIGN AND SIZING

2.1 PURPOSE

Local sewerage and water facilities are considered to be engineered improvements which are designed for specific applications. All designs, drawings and specifications must be prepared by, or under the direction of a Professional Engineer registered in Colorado, whose seal must be on a record set of documents. Local collection systems and water distribution systems are the responsibility of the Developer, who is responsible for design and construction and the costs thereof and for payment of actual costs of design reviews and other reviews and inspections provided by the Town. The standard details and specifications contained herein are minimum design standards which the Town will accept in order to facilitate perpetual operation and maintenance procedures.

2.2 OWNERSHIP OF FACILITIES

All existing and future Regional and Local Facilities connected with and forming an integral part of the Systems and accepted for operation and maintenance pursuant to these Standards shall become and are the property of the Town, unless a contract between the Town and the Owner provides otherwise. That portion of all existing and future Service Lines extending from a main to each resident, unit or building for each customer that is connected with the System shall become and is the property of the Owner/Customer (See Section 4 for further descriptions of Customer Ownership).

2.3 DRAWINGS

Unless otherwise approved by the Town, all design drawings shall be 24" x 36" in size. Drawing scale for area plans shall be 1" = 50'. Submission of ½ size sets (at scale) are acceptable for review purposes.

Prior to the construction or installation of any Local Facilities, the Developer shall submit Design Documents with appropriate fees to the Town for review and approval. [The Developer is encouraged to submit preliminary designs for review of the overall layout, prior to producing this set of design drawings for review.] Each review package submitted to the Town shall consist of four (4) sets, and a cover letter describing the project. Two copies are for the Town, and two copies are for review by the Town's Engineer. The Developer must also make an independent submittal to the Elizabeth Fire Department. The Town and/or its Engineer may request additional documentation or calculations, depending on the complexity of the application.

The cover sheet of each design drawing set shall have an "approval block" affixed thereto which provides for the signatures of authorized representatives of the Town of Elizabeth, the Town's Engineer, and the Elizabeth Fire Department. The "approval block" shall be a facsimile of that appended to these Standard Specifications, "Standard Approval Block," Drawing G1. Drawings

submitted for approval must be stamped and signed by a Professional Engineer registered in Colorado.

Construction may not begin until the Design Documents have been approved by the Town. The construction contractor(s) must have a copy of the signed, approved design documents in their possession at the construction site.

After completion of construction, the Developer shall also provide a complete set of record drawings for the facilities. The record drawings shall show sufficient dimensioned ties to reasonably permanent surface features for all buried facilities to allow for future locating. One copy of the record drawings, stamped and signed by the P.E. must also be submitted for the Town's records, along with an electronic copy on CD in the latest version of AutoCAD and also in PDF format.

2.4 EASEMENTS

Where Local Facilities are to be located out of the public right-of-way, the Developer shall be responsible for obtaining easements required for the construction, maintenance, and operation of the facilities. The Town will not accept alignments that could present access or construction problems in present or in the future (e.g., steep slopes or difficult vehicular access).

The legal description for the easements shall be prepared by a Professional Land Surveyor, registered in the State of Colorado. Easements shall be in a form acceptable to the Town and shall be shown on the construction drawings. The Town will not approve the Contract Documents until all required easements have been deeded to the Town.

In general, the minimum width of easements for pipelines shall be 30 feet. Temporary construction easements shall have a minimum width of 40 feet. Wider easements may be required for deep sections of pipeline, multiple lines, storm sewers, or where otherwise required by the Town. In general, an easement containing a water line and a sewer line shall be no less than 36 feet in width. No water line shall be located less than 5 feet from the edge of easement and no sewer main shall be located less than 10 feet from the edge of easement.

2.5 SEWER COLLECTION SYSTEM REQUIREMENTS

The Sewer Collection System is for the disposal of water contaminated by biodegradable wastes. No Person shall make connection of roof downspouts, exterior foundation drains, areaway drains, surface drains or other sources of surface runoff or groundwater to a building sewer or building drain which in turn is connected directly or indirectly to the Sewer Collection System. In order to protect the Sewer Collection System from damage, destruction, deterioration, misuse or malfunction and to guard against health hazards and the creation of public nuisance, the following regulations shall apply relative to the discharge of Sewage containing deleterious wastes.

A septic facility may not be utilized within the Town Service Area unless a waiver is obtained from the Town.

2.5.1 Specially Regulated Wastes

- a) Industrial Wastes. No Person or Persons shall discharge or cause to be discharged any Industrial Waste of any type into the Sewer Collection System unless written permission is received from the Town.
- b) Inflow/Infiltration. No Person or Persons shall discharge or cause to be discharged into the Sewer Collection System, storm drainage from ground surface, roof ladders, catch basins or any other source, or sub-surface drainage or ground water.
- c) Other Wastes. Industrial cooling water, unpolluted process waters, bakery/restaurant wastes, car washing wastes, swimming pool drainage and floor drainage from enclosed and covered areas may be connected to the Sewer Collection System only by a special Permit from the Town. The application for such a Permit, in addition to information normally required for a Permit application, shall include the following:
 - Name and address of the Owner.
 - Location of the property for which the request is made.
 - Description of the facility or operation requested for connection.
 - Estimated quantities and qualities of the waste to be discharged including maximum rates.
 - Plans and specifications of related waste generating processes and any pretreatment processes.

Such Permits issued by the Town may contain the following conditions:

- the construction of flow measuring and/or sampling devices;
- the construction of valves or gates to stop flows on an emergency basis;
- the construction of grease, oil or sand interceptors, or other pretreatment facilities;

or the Town may place other restrictions on the Permit as reasonably required under the circumstances. Nothing in this Section shall prohibit the Town from denying an application for a Permit if the Town determines that the demand on the System(s) impairs the Town's existing operations or use.

2.5.2 Prohibited Wastes

Toxic or non-biodegradable waste or any other waste which results in effluent not being within state standards after providing conventional treatment shall not be discharged into the Sewer Collection System. No drain accepting discharge from vehicle wash racks, filling stations, restaurants or other building sewers as specified by the Town shall be connected to any Sewer Service Line unless the discharge first passes through an acceptable grease, oil or sand interceptor. Except as provided herein, no Person shall discharge or cause to be discharged any of the following described waters or wastes to the Sewer Collection System:

- a. Any liquid or vapor having temperatures higher than one hundred and four degrees Fahrenheit (104° F).
- b. Any water or waste which may contain more than one hundred parts per million (100 ppm) by weight of animal or vegetable fat, oil or grease.
- c. Any gasoline, benzene, naphtha, fuel oil or other flammable or explosive liquid, solid, gas, oil or grease, distilled alcohol
- d. Any garbage that has not been properly shredded to less than one-half inch (½") in the largest dimension.
- e. Any ashes, cinders, sand, mud, straw, shavings, metal, glass, rags, feathers, tar, plastic, wood, paunch manure or any other solid or viscous substance capable of causing obstruction to the flow in sewers or other interference with the proper and normal operation of the Sewer Collection System.
- f. Any waters or wastes having pH lower than 5.0 or higher than 9.0, or having any other corrosive or toxic property capable of causing damage or hazard to structures, equipment or personnel of the Sewer Collection System.
- g. Any water or wastes containing a toxic or poisonous substance in sufficient quantity to injure or interfere with any Sewage treatment process, constitute a hazard to humans, animals or fish, or create any hazard in the receiving waters of the sewer treatment plant effluent.
- h. Any waters or wastes containing suspended solids of such character and quantity that unusual attention or expense is required to handle such materials at the sewer treatment plant.
- i. Any noxious substances or malodorous waste, waters, gases or substance capable of creating a public nuisance, either in the sewer or at the sewer treatment plant.
- j. A five (5) day B.O.D. concentration greater than three hundred parts per million (300 ppm).
- k. A concentration of more than three hundred parts per million (300 ppm) of suspended solids.
- l. Concentrated wastes from septic tanks and portable sanitary devices.
- m. A peak flow rate greater than five (5) times the average flow rate.
- n. Any chemicals having a twenty-four (24) hour proportionate composite sample concentration at the point of discharge in excess of the following:

Cadmium	0.10 mg/L
Chromium	5.0 mg/L
Copper	3.0 mg/L
Cyanides	2.0 mg/L
Iron	15.0 mg/L
Phenol	10.0 mg/L
H ₂ s (Hydrogen Sulfide)	1.0 mg/L
Zinc	2.0 mg/L

2.5.3 Pretreatment

Where necessary, as determined by the Town, whose determinations shall be final, the Customer shall provide, at its sole cost and expense, such preliminary treatment as may be deemed

necessary. Where preliminary treatment facilities are provided for any waste or water, they shall meet with the approval of the Town for adequacy of design, and once built, shall be maintained continuously in satisfactory and effective operation by the Customer. When required by the Town, the Customer of any property served by a Service Line carrying Industrial Wastes shall install a suitable control manhole or monitoring point in the building sewer to facilitate observation, sampling and measurement of the Industrial Wastes. Such manhole or monitoring point shall be accessible and safely located and constructed in accordance with plans and specifications approved by the Town. The manhole or monitoring point shall be installed and maintained by the Customer at its expense.

2.5.4 Sump Pumps and Illegal Devices

No plumbing fixture, device, construction or plumbing system shall be installed within any building or improvement which will provide a connection between the Sewer Collection System, directly or indirectly, or with a Sewer Service Line for the purpose of draining ground or surface waters into the Sewer Collection System, and no physical connections shall be permitted whereby a Sewer Service Line is connected to a sump pump or other facility in such a manner that through either the manipulation of valves, the lack of back pressure valves, or as a result of any other arrangement or connection, it is possible to drain flood, overflow, storm or ground water directly or indirectly into the Sewer Collection System. Any Person having connected, or permitting to be connected, such a system to a Sewer Service Line or a Sewer Main, may be given notice to immediately disconnect such device or pumping system at his cost, and upon failure to do so, the Town may forthwith disconnect any Sewer Service Line from the property containing such a forbidden device or pumping system at the Sewer Main. The cost of such disconnection shall be a lien and charge against the property involved. No Sewer Service Line shall thereafter be connected to the Sewer Collection System without payment of the re-connection fee to the Town, and all costs and expenses of the Town relative thereto and positive proof that such improper and illegal connection or device has been removed and will not thereafter be re-connected to the Sewer Collection System.

2.5.5 Grease, Oil or Sand Interceptors

- a) General - Design, Installation and Location. Grease, oil or sand interceptors shall be provided and installed at the sole cost and expense of the Customer when, in the opinion of the Manager, they are necessary for the proper handling of liquid wastes containing greases, oil, etc., in excessive amounts, or any flammable wastes, sand or other harmful ingredient. Fixtures that must be connected include, but are not limited to all kitchen service drains, scullery sinks, pot and pan sinks, dishwashing machines, soup kettles, garbage disposals and floor drains located in areas where materials containing grease may exist. Toilets, urinals, and similar fixtures shall not be connected to the interceptor. Upon prior approval by the Town, interceptors will not be required for facilities where food is served but not cooked at the facility, and/or no equipment or utensils associated with the preparation or service of cooked foods are washed at the facility. At a minimum, the interceptor shall be designed in accordance with the 2012 International Plumbing Code (IPC). The Customer shall also submit the proposed menu as part

of the sizing calculations. The Town reserves the right to adjust the proposed sizing based on the proposed menu. All interceptors shall be located as to be readily available and accessible for cleaning and inspection. Grease, oil or sand interceptors shall be constructed of impervious materials capable of withstanding abrupt and extreme changes in temperature. Interceptors shall be watertight, and, if necessary, as determined by the Town, gastight and vented.

- b) **New Buildings:** Interceptors for new buildings shall be approved by the Town and shall have a minimum of two (2) compartments with fittings designed for grease, oil and/or sand retention. There shall be at least two (2) manholes lids for each interceptor to provide access for cleaning and inspection of all fixtures and compartments. Interceptors for new buildings shall be located outside of the facility served and will not be allowed in drive-through driveways or next to main entranceways. Location of all interceptors shall be approved by the Town and shall be shown on the approved final development plan. Grease interceptors shall conform to Detail S6 and sand/oil interceptors shall conform to Detail S7, as applicable. The volume of a grease interceptor shall be determined by multiplying the total rate of flow in gallons per minute from each fixture required to be connected to the interceptor times a minimum retention time of not less than 15 minutes, the resulting volume expressed in gallons. The minimum acceptable grease interceptor volume shall be not less than 750 gallons. The flow rate from each fixture is provided in the following schedule:

TYPE OF FIXTURE	RATE OF FLOW (GPM)
Floor drain/sink	10
Restaurant kitchen sink	15
Single compartment scullery sink	20
Three compartment sinks	35
Two single compartment sinks	25
Two double compartment sinks	35
Restaurant dishwasher:	
up to 30 gallon water capacity	15
30 to 50 gallon water capacity	25
50 to 100 gallon water capacity	40
Garbage disposal/grinder	35

The volume of a sand/oil interceptor shall be determined as depicted in the following with a minimum acceptable volume of not less than 500 gallons.

Parking Garage – A base of forty-five (45) gallons plus eight (8) gallons per ten (10) vehicles
 Repair Garage, Warehouse – A base of Forty-five (45) gallons plus eight (8) gallons per one hundred (100) square feet of building area.

- c) Maintenance and Inspection. Where installed, all grease, oil or sand interceptors shall be maintained by the Customer at its sole cost and expense, in continually efficient operation at all times. The Town requires a monthly or periodic cleaning and pumping of any grease, oil or sand interceptors. The Customer shall maintain

a cleaning and maintenance record. At a minimum, the previous two years' maintenance records shall be filed at the property for periodic review by the Town. The Town may make inspections of grease, oil or sand interceptors and in the event the Customer/Owner is in violation of these requirements, the Customer/Owner may be liable for payment of a penalty (Per EMC 13-6-50). The cost of the Town's inspections may be billed directly by the Town to the Customer and/or Owner and, in addition, may include all other costs incurred by the Town in inspecting the interceptor.

2.5.6 Private Lift Stations

The Town will allow the construction and use of a private lift station if the customer or the engineer or representative working on behalf of the customer has exhausted all avenues of providing a gravity lateral sewer. In the event a private lift station is installed, the private lift station is the sole responsibility of the customer. The lift station shall be designed and permitted (if applicable) in conformance with CDPHE standards. Expenses associated with operating and maintaining the lift station shall be the responsibility of the customer. The Town shall be granted access to inspect the lift station upon request and reserves the right to isolate the system due to any violations of these Standards. .

2.5.7 Swimming Pools

No public or private swimming pool shall be connected to the Sewer Collection System without first obtaining a special Permit from the Town. Such Permit shall define and specify the hours during which water may be discharged from such pools into the Sewer Collection System.

2.6 SEWER MAIN DESIGN / SIZING

Collection sewer system design is intended to provide gravity service only. Before the start of design, the Developer is to contact the Town Engineer to confirm the connection point with the existing sewer system. Sewer line sizing is to be approved by the Town Engineer. The Town may direct the Developer to provide sewer line capacity in excess of the Developer's requirements. In such cases, the Town may negotiate reimbursement to the developer for the incremental cost of the oversize. Sewage lift stations and force mains will not be permitted unless specifically authorized by the Town.

Collection sewers shall be designed to carry not less than the projected peak flow rates flowing half full (safety factor = 2.0), unless otherwise approved by the Town Engineer. The minimum size collection sewer shall be 8" diameter. Sewers shall be so designed and constructed to give mean velocities, when flowing full, of not less than 2 feet per second.

When located in public streets, sewer mains shall be positioned on the west and south sides of the street center line. The mains shall be located proximately 5 to 10 feet from road center line and a minimum distance of 5 feet from the lip edge of the gutter pan (See Drawing G2). Sewers

shall generally be designed with sufficient depth to serve basements by gravity. The minimum cover shall be 6 feet from top of sewer to finished grade.

Water and sewer lines shall have a 10 feet minimum horizontal separation. Where this separation is impractical, the Town may permit other separation requirements, in accordance with applicable standards. If a water line passes under a sewer main or service, or if it lies within 10 feet of the sewer, the water line is to be protected per Drawing G3 and Drawing G4. When specifically authorized by the Engineer, other encasement or water line protection alternatives may be permitted. Manholes shall be located at a maximum spacing of 300 feet center-to-center and also at changes in sewer pipeline alignment and/or grade and at the end of each line. Sewers shall be laid with uniform slope between manholes.

Drop manholes (per Drawing S3) are to be provided for any pipeline whose invert entering the manhole is greater than 24" above the invert out.

2.7 WATER SYSTEM REQUIREMENTS

The Town Water Distribution System has been planned and constructed to provide Potable Water for conventional domestic and commercial uses and fire protection and irrigation. Any application for industrial or a high-demand commercial water supply, which use could be expected to require large quantities of water or unusual demand rates, shall be required to submit demand data before a Permit will be issued and said Permit may contain use limitations as determined to be necessary by the Town.

Water from the Water Distribution System and water from any other source shall be distributed through systems entirely independent of each other and Cross-Connection between such supplies is prohibited. Where any potential of backflow is present, a protective device or system, acceptable to the Town, shall be installed to prevent its occurrence. The installation, testing and maintenance of the protection device shall comply with the Backflow Prevention and Cross-Connection Control standards presented in Section 5.

All lawn sprinkler systems shall be equipped with a vacuum breaker approved by the Town.

2.8 WATER DISTRIBUTION DESIGN / SIZING

Water mains shall be designed to meet the more stringent of the following two conditions:

- a. Maximum hourly demand with pressures not less than 40 psi at any point of the distribution system, or
- b. Maximum daily demand rate plus fire flow demand (as determined by ISO guidelines) with delivery pressures of not less than 20 psi at the hydrant.

The normal minimum size water distribution main shall be 12" or 8" for short looped lines in single-family residential areas. Six-inch mains may be individually approved by the Town for

dead-end mains serving no more than 15 residences with a fire hydrant near the end of the line, if this location and delivery rate meet the requirements of the Elizabeth Fire Department. Main line gate valves shall be located at a minimum frequency of every 600 feet and at all intersections. Crosses or tees shall include isolation valves on all legs, unless otherwise directed by the Town.

Water main sizing and connections shall be reviewed with the Town's Engineer prior to final detailing and drafting. The systems shall be designed to maximize interconnections and strengthening of the Town's water system. Where certain lines may also have a transmission function, in the opinion of the Town, the Town may direct that such lines be oversized.

Regulations normally require a 10-foot minimum horizontal separation between water and sewer mains. When located in public streets, potable water pipelines shall normally be positioned on the east or north sides of the street center line. The mains shall be located proximately 5 to 10 feet from road center line and a minimum distance of 5 feet from the lip edge of the gutter pan (See Drawing G2). Curved water line alignments are to be avoided if the water line is laid in the same easement or roadway as a sewer line.

2.9 INSPECTIONS

New installations, replacements, or repairs to the water distribution or sewer conveyance lines shall be inspected and approved by the Town or the Town's designated Inspector. All work shall be performed in accordance with accepted workmanship practices and the specifications set forth and referenced herein. Any work not accepted by the Town shall be redone until compliant with these Standards. All appropriate permits and approved plans shall be kept on the job site during construction. After receipt of approved plans from the Town the Applicant shall give at least 48 hours notice to the Town prior to starting construction.

2.10 ACCEPTANCE CHECKLIST

Checklist for Acceptance of Town Facilities. To be completed after construction and prior to any service connections.

1. Construction of all Town facilities completed to Town Standards and to the approved plans.
2. All facilities tested to Town Standards and accepted by the Town's Engineer. (Furnish copies of soils compaction and materials tests).
3. Permanent survey monuments set at the corners of all easements.
4. Record drawings meeting Town Standards and sealed by a registered Professional Engineer (Hard and Electronic Copies).
5. Furnish a summary of total construction costs (including design costs) of all applicable water and sewer facilities. Include only facilities to be deeded to the Town.

6. Warranty Deed for all facilities to be owned by the Town.
7. Two-year Maintenance Bond to begin after the date of acceptance, except that if deficiencies are identified and repaired, a new two-year maintenance bond for the repaired Work is to begin starting on the date of acceptance of the repaired Work.
8. Payment of all fees and confirmation from Town's Attorney that the applicant for dedication of the facilities is not in default under any agreements within the Town.
9. Electronic Copy (CD) of sewer main video following initial acceptance (see Section 3.5.3)

SECTION 3
LOCAL SEWER AND WATER STANDARDS

SECTION 3

LOCAL SEWER AND WATER STANDARDS

3.1 PURPOSE

The standard details and specifications contained herein are minimum design standards which the Town will accept in order to facilitate perpetual operation and maintenance procedures. In addition, the engineer must also design in accordance with the minimum standards of other regulatory agencies. Review and approval of local facilities designs by the Town, its Engineer or other agencies (Elizabeth Fire Department) shall not relieve the Engineer of Record from responsibility for adequate design.

3.2 SANITARY SEWER MATERIALS

Pipe: Sewer pipe and fittings, 15 inches and smaller, shall be polyvinyl chloride (PVC), SDR 35 minimum thickness conforming to ASTM D3034. Joints shall be of the "slip on" type with integrally cast bell having an elastomeric gasket. For non-standard sewer line applications (e. g.: steep terrain; crossings of streams, ditches or drainages), the Town Engineer will issue project-specific requirements on request.

Manholes: Manhole bases, barrels and tops shall be precast concrete units conforming with ASTM C-478. Concrete for manhole bases and other similar items shall have a 28-day compressive strength of not less than 3,000 psi. All reinforcement required shall be standard deformed reinforcement conforming to the requirements set forth in ASTM A615, Grade 40.

The top section required for change of diameter shall be eccentric cone or flat top as depicted on Standard Drawings S2, S3, and S4. To bring the manhole cover to the correct elevation, the adjustment section of each manhole shall be pre-cast concrete grade adjustment rings. These rings shall be not less than 6 inches wide and furnished in heights to allow for 1-inch adjustment. Total adjustment height with grade rings, shall not exceed 12 inches.

Gaskets (O - rings) or flexible connection boots for connecting PVC pipe to manhole sections shall be specifically manufactured for that purpose. The gasket on boot shall be provided by the manhole manufacturer.

Manhole Joints: the joints between precast manhole sections are to be sealed with Ram-Nek LTM by Henry Company, or approved alternate gasket material.

External Joint Sealing: In addition to the gasket material used within the joints between sections of the manhole, an external joint wrap is required. Wrap is to be no less than 8" wide and is to be ConSeal CS-202 Butyl Rubber external joint wrap or Ram-Nek or approved equal.

Manholes for sewers of 15" diameter or less shall have a minimum inside diameter of 4 feet. Consult the Town's Engineer for requirements for larger sewers. Manholes shall be constructed and installed in accordance with the Standard Drawings S2, S3, S4 and S5. Manholes in open

fields shall be designated with surface markers (see Drawings G5). Surface markers shall be flexible plastic manufactured by Carsonite or approved equal and shall be yellow in color with imprinted letters identifying sewer size and manhole number.

Manhole Covers: Manhole frames and covers shall be cast iron with the word "SEWER" cast on the cover. Unless otherwise specified, manhole lids shall be gasketed, unbolted lids, per Neenah R-1500 "self-sealing", or approved equal. If a gasketed, bolted lid is called for, it shall be Neenah Model R-1915-S1, or approved equal. Manhole covers shall include plastic infiltration inserts to protect against drainage inflow.

Manhole Steps shall be treaded, injection-molded polypropylene encapsulating a 112" grade 60 reinforcing rod. Shall be M.A. Industries step, Model PS-1 PF, or approved equal.

3.3 WATER MAIN MATERIALS

All water mains shall be Blue C900 or C905 PVC, conforming to ASTM 2241. Pipe joints shall be push-on type.

Fittings shall be ductile-iron, minimum 250 psi minimum working pressure, conforming to AWWA GI53 or C110 with mechanical joint connections meeting AWWA C111. Fittings shall have a cement mortar lining meeting AWWA 104 and bituminous exterior coating.

Sheathing: All ductile-iron, valves, and fittings shall be polyethylene sheathed in accordance with ANSI A21.5, AWWA C105, 10 mil minimum thickness.

Tracer Wire: A ten-gauge insulated tracer wire shall be required for all water mains. Wire termination boxes shall be provided, as depicted in Drawing W5.

Location Tape: All water lines shall be marked using blue detectable utility marking tape placed 8 to 10 inches below grade. The tape shall be PVC material 6-inches wide with a thickness of four (4) mils.

Surface Markers: Gate valves in open fields shall be designated with surface markers (see Drawings G5). Surface markers shall be flexible plastic manufactured by Carsonite or approved equal and shall be blue in color with imprinted letters identifying main size and valve number.

Pipeline Insulation: Where required at depths less than specified. Insulation shall be Dow STYROFOAM 115 or approved equal.

Line Valves: Line valves shall be provided to allow isolation of parts of the system for maintenance or repair. They are required approximately every 600 feet, or more frequently at intersections of mains to allow isolation of loops and branches. Line valves shall be provided on the legs of all cross and tee fittings, unless otherwise approved by the Town. A line valve is required between fire hydrants. Line valves shall comply with requirements for "Buried Valves."

Buried Valves: Valves, 12" and smaller, shall be non-rising stem, bronze mounted gate valves with mechanical joint ends conforming with AWWA C509. Valves shall have 2" square operating nuts and open left (counterclockwise rotation). Valves shall be Mueller, Clow, Waterous, or approved equal.

Valve Boxes: Each buried valve shall be provided with a cast-iron valve box and round cover. The box shall have a minimum inside diameter of 5 1/4" and be adjustable in length and of the screw type. The word "WATER" shall be cast on the cover. Valve boxes shall be "wide oval base" by Tyler, Clow, or approved equal. Valve boxes shall allow for at least 3 additional extensions above the level required for final grade at the time of installation. The top of all valve stems (including extensions) shall be located between 42" and 48" below final grade (See Drawing W6).

Fire Hydrants: Fire hydrants shall be of the dry barrel type and conform with AWWA C502. Hydrants shall have a 5 1/4" main valve, two 2-1/2" hose connections and one 4 1/2" pumper connection. Hydrants shall have 6- inch mechanical joint connections and safety traffic flange. Operating and cap nuts must be 1 1/2", Number 17 National Standard hex main valve that opens left. Fire hydrants shall be Mueller Centurion No. A-423, Waterous Pacer WB-67 with bronze seat ring, or approved equal (See Drawing W7).

Blowoffs: Blowoffs shall comply with Drawing W8. The top of all blowoff valve stems (including extensions) shall be located between 42" and 48" below final grade.

Air-Release Valves: Shall be provided at high points in the water distribution system. This may take the form of a fire hydrant or 2" blowoff (both manually operated), or an automatic air-release valve (See Drawing W9). The proposed location and use must be pre-approved by the Town.

Mechanical Joint Restraint: Joint restraint devices shall be made of ductile iron. Joint restraint devices shall be EBAA Iron, Inc., Megalug Series 1100 or 1700 or Uni-Flange Corp. Series 1400 or accepted equal.

Casing Spacers: Carrier pipes to be installed inside casings shall be installed with self-restrained casing spacers. Casing spacers shall provide axial thrust restraint to prevent pipe joint deflection during and after installation. They shall also provide dielectric insulation between the carrier pipe and the casing and facilitate installation of the carrier pipe into the casing. Spacers shall be installed at a maximum of every ten (10) feet of the pipeline to support the pipe barrel and the weight of its contents. Casing spacers shall be manufactured by Uni-Flange or Cascade Waterworks or approved equal.

3.4 INSTALLATION

3.4.1 Sewer Installation

The sewer system shall be installed in a thorough, workmanlike manner in accordance with the Design Documents that have been approved by the Town. The minimum bedding and backfill requirements shall be as shown on Drawing S1 and described in these standards.

The minimum cover shall be 6-feet from top of sewer line to finished grade. A minimum of 5-feet of cover will be allowed if at least 2 inches of an approved pipeline insulation is provided, per Drawing S1. If insulation is installed, use approximately 6-inches of sand or squeegee for the pipe zone materials above and beneath the insulation to protect it from breakage during backfill.

If the bottom of the excavation is soft or unstable, and in the opinion of the Town, is not a satisfactory support for the pipeline, further depth and/or width shall be excavated and refilled to 6-inches below the pipe outside diameter (excluding bells) with Trench Stabilization Material, as specified in Section 3.4.6.

Each pipe length and fitting interior, interior surface of bells, and exterior surface of spigots shall be cleaned of all foreign material before placing it in the trench and shall be kept clean all times thereafter. Each item must also be examined for cracks and other defects before installation.

Pipe shall be cut, only whenever necessary, to conform to location of manholes or connections. All cuts shall be straight, true, and at right angles to the axis of the pipe unless otherwise noted or directed by the Engineer. The cutting process shall leave a smooth end without damaging the pipe. All burrs shall be removed from the ends of cut pipe, and the end chamfered and lightly rasped or filed. All tools used in cutting pipe shall be subject to the Engineer's approval. The manufacturer's requirements for lubrication and gaskets must be followed.

Pipe laying shall proceed upgrade with the spigot ends of pipe pointing in the direction of the flow, unless otherwise approved by the Engineer. Each pipe length shall be laid true to line and grade in such manner as to form a close concentric joint with the adjoining pipe and to prevent sudden offsets to the flow line. Pipe shall be laid in an unwatered trench and shall not be used for draining water from the trench. Pipes are to be kept clean by capping or plugging ends.

3.4.2 Manholes

Manholes shall be constructed to conform to the Standard Details. The invert channels shall be smooth and semi-circular in shape, conforming to the inside of the incoming and outgoing sewer pipelines. Changes in direction of flow shall be made with a smooth curve of as large a radius as the size of the manhole will permit. Changes in size and grade of the channels shall be made gradually and evenly. Where differences in invert elevations exist, sloped flow channels shall be formed so the sewage does not undergo a vertical drop. The invert channels may be formed directly in the concrete of the manhole base. The floor of the manhole outside of the channel shall have a rough broom finish and shall slope toward the channels not less than 1 inch per foot nor more than 2 inches per foot. The top circumference of the base shall be finished level and

smooth to permit obtaining a watertight joint between the precast manhole sections and the cast in place base. The manhole covers shall be set with their tops at the grades set forth in the approved drawings. When a manhole top is above the ground line, the exposed ring shall be encased in non-shrink grout as shown on the Standard Details. Manhole tops without bolted, gasketed covers shall not be set at or below surrounding grade, except in paved roadways. The site shall be graded so that drainage is away from the manhole.

Each joint of the precast manhole barrel shall have at least one continuous Ram-Nek gasket placed on the lower ledge before the barrel immediately above is lowered into place.

For poured-in-place bases (See Drawing S5), joints between the precast manhole barrel sections and the cast in place manhole bases shall have two continuous gaskets and shall be grouted inside and outside using approved non-shrink grout. With a poured-in-place base, the surface of the precast barrels and the cast in place bases shall be smooth and sound. The joint surfaces shall be cleaned to remove any concrete projections or dirt which may prevent a water-tight seal from being established. The joints shall be prepared and the gaskets shall be placed in accordance with the manufacturer's recommendations.

External Joint Sealing Wrap is to be applied to clean concrete surfaces per manufacturer's requirements. Must be applied immediately prior to backfilling, so when backfill is compacted the earth pressure forces bituminous wrap into concrete surfaces. Temperature of manhole sections and of backfill materials must be above 40 deg. F from time of applying wrap to time of backfilling.

3.4.3 Underdrains

The Town does not allow the use of underdrains laid in the same trench as a sanitary sewer line.

3.4.4 Waterline Installation

Water pipelines shall be installed in a thorough and workmanlike manner in accordance with the Design Documents that have been approved by the Town. The minimum bedding and backfill requirements are depicted on Drawing W1 and described in Section 3.4.6. The minimum cover shall be 5 feet from top of water line to finished grade. Pipelines shall not be placed deeper than 10 feet without prior approval by the Town.

A minimum of 3 feet 6-inches of cover will be allowed if at least 8 inches of an approved pipeline insulation is provided, per Drawing W1. If insulation is installed, use approximately 6-inches of sand or squeegee for the pipe zone materials above and beneath the insulation to protect it from breakage during backfill.

If the bottom of the excavation is soft or unstable, and in the opinion of the Town, is not a satisfactory support for the pipeline, further depth and/or width shall be excavated and refilled to 6-inches below the pipe outside diameter (excluding bells) with Trench Stabilization Material, as specified and detailed in Section 3.4.6.

All pipeline fittings (i.e., bends, tees, plugs, and caps) shall be installed with concrete thrust blocks adequately designed for the specific application and mechanically restrained for at least 40 feet in all directions. Thrust blocks shall be cast-in-place from concrete having a minimum compressive strength of 3,000 psi. Minimum requirements for horizontal and vertical thrustblocks are as shown on Drawing W2 and W3.

Alternate means of thrust restraint may be considered and approved for use where proved to provide similar restraint. Supplemental restraint may also be required where the Engineer believes the soil bearing pressures to be inadequate, or where the Engineer is concerned about subsequent movement due to slope or other conditions of service. See Drawing W4 for mechanical joint restraint lengths and details. Valves near a fitting must be tied back to that fitting, using rodding or mechanical joints.

All dead ends shall be terminated with a fire hydrant or blow-off.

3.4.5 Fire Hydrant Installation

Fire hydrants shall be located as required by the Town and the Elizabeth Fire Department and shall be placed at a maximum interval of every 500 feet. The Developer shall be required to obtain the approval by the Elizabeth Fire Department for fire hydrant locations. In general, hydrants shall be located at a minimum of 18-inches behind curbs or sidewalks. Fire hydrants shall be installed in accordance with Drawing W7. Each hydrant shall be connected to the main by a six-inch (6") branch line. An independent six-inch (6") gate valve shall be installed on the tee off the water main. The length of the branch fire line shall be a maximum of 50 feet and no service line connections shall be made on the fire hydrant branch line.

3.4.6 Sewer and Water Main Pipe Bedding and Backfill

- a. Trench Zones. The terms "Bedding Zone", "Pipe Zone" and "Backfill Zone" shall refer to the trench zones identified in the Standard Details S1, and W1.
 - 1) Bedding zone. The Bedding Zone shall consist of all material placed below the pipe invert or, when permitted, the native materials graded and prepared for direct placement of the pipe.
 - 2) Pipe zone. The Pipe Zone shall consist of all material placed above the pipe invert to an elevation shown on the details.
 - 3) Backfill zone. The Backfill Zone shall consist of all material above the Pipe Zone.
- b. Material. All bedding and backfill material shall have the approval of the Engineer. All bedding and backfill material shall be free of frozen material, organic material and debris. The materials to be used in each trench zone are indicated on the Standard Details and these materials are described below. All materials may be subject to gradation tests and compaction tests prior to approval of the use of that material. The test results shall be submitted to the Engineer for approval and verified as to their accuracy. These tests shall be performed at no cost to the Town or its agents.

- 1) Sand bedding or sand backfill material. This material shall be a clean, well-graded sand and shall conform to the following limits when tested by means of laboratory sieves:

Well-Graded Sand

Sieve Size	Total Percent Passing by Weight
3/18 – inch	100
No. 4	70 - 100
No. 8	36 - 93
No. 16	20 - 80
No. 30	8 - 65
No. 50	2 - 30
No. 100	1-10
No. 200	0 - 3

- 2) Roadbase bedding material or roadbase backfill. This material shall be Class 6 aggregate base course as specified by the latest version of the State of Colorado Department of Highways; and shall meet the following gradation:

Sieve Size	Total Percent Passing by Weight
¾ – inch	100
No. 4	30 - 65
No. 8	20 - 55
No. 200	3 - 12

- 3) Squeegee Sand. This material shall be clean, well graded and conform to the following limits when tested by means of laboratory sieves:

Sieve Size	Total Percent Passing by Weight
3/8 – inch	100
No. 200	0 – 5

- 4) Granular bedding or granular backfill material. This material shall be imported crushed rock or angular surfaced gravel and meet the following gradation (ASTM D448, No. 67):

Sieve Size	Total Percent Passing by Weight
1 – inch	100
¾ - inch	90 – 100
3/8 – inch	20 -55
No. 4	0 – 10
No. 8	0 - 5

- 5) Select material. Select material shall not be permitted unless authorized by the Engineer. This material shall consist of suitable material screened from the excavated earth having no rocks or stones greater in size than ¾-inch.
- 6) Trench stabilization material. This material shall be a ¾ inch to 1½ inch uniformly-graded, crushed rock or concrete aggregate.
- 7) Backfill material. Backfill material shall consist of suitable material from the excavated earth, meeting all the requirements of these standards.

No boulders over 6 inches in any dimension shall be allowed in the top 12 inches of the trench. All boulders shall be carefully placed so that no damage will be done to the pipeline. No backfill material shall have boulders larger than 24 inches in any dimension and the amount of boulders larger than 8-inches shall be less than 15% of the backfill volume. Boulders larger than 8 inches in any dimension shall be carefully lowered into the trench until the backfill is 4 feet over the top of the pipe.

c. Bedding and Backfill Installation:

- 1) General. The compaction requirements for the backfill zone shall conform to maximum dry density according to ASTM D698, Moisture-Density Relations of Soils (Standard Proctor). For the bedding and pipe zones, and when the ASTM D698 test is not applicable, the percentage compaction requirements shall conform to ASTM D4253, Test for Relative Density of Cohesionless Soils.

The Developer is responsible for providing (at no cost to the Town) adequate materials testing and/or geotechnical engineering resources to provide proper Quality Control and response to Quality Assurance directives by the Town or its agents. At a minimum, moisture density tests shall be taken one test for every 24-inch lift per 200 linear feet of trench and at every above ground appurtenance (i.e. valve box, manhole, hydrant, etc.)

When required by the Town, the Developer shall excavate backfilled trenches for the purpose of performing compaction tests at locations and depths required by the Engineer. The Developer shall be responsible for reinstalling and compacting the test excavations at no additional cost to the Town.

- 2) Bedding zone installation. Bedding material shall consist of the material on which the pipe is placed in accordance with the Drawings S1 and W1. Bedding material shall be placed to the required elevation of the pipe invert. Tamping and/or vibratory equipment shall be used to thoroughly tamp the bedding material to a minimum 75 percent relative density.

- 3) Pipe zone installation. After bedding material has been placed and approved and after the pipe has been installed and approved, the pipe zone backfill shall be installed to an elevation shown on the Standard Drawings.

The pipe zone material shall be as specified on the details and shall be placed and compacted in distinct, separate lifts not to exceed 6 inches of loose depth; except that the first loose lift shall not be higher than the pipe centerline (springline). If select backfill materials are permitted in this zone but acceptable select backfill material (suitable for placement within 12 inches of the pipe barrel) is not available at any particular location, the Developer shall use imported granular backfill material. Compaction shall meet the requirements of "Bedding Zone Installation," utilizing T-bars or mechanical tamping equipment.

- 4) Backfill zone installation. Unless otherwise provided in the Special Construction Provisions, the following method of installation shall apply. After the pipe zone backfill has been placed and approved, the trench shall be backfilled. All backfill above the pipe zone backfill shall be carefully placed in the trench in lifts no greater than 2 feet loose lifts. Each lift shall be compacted by mechanical equipment to 95 percent of laboratory dry density. After the trench is backfilled to the ground surface, the trench line shall be wheel rolled. If the backfill is depressed below the finished grade elevation, the depressed area shall be refilled and compacted. The backfill shall be mounded higher than the adjacent ground to allow for settlement.
- 5) Backfill zone installation in roads and streets. Beneath all traveled ways in roads and streets, highway shoulders and within 15 feet of pavement in State Highway Department rights-of-way (unless otherwise specified on the plans) backfill shall be carefully placed and compacted up to the limit of base course material or to gravel. Compaction shall be by mechanical tamping in 8-inch maximum loose lifts using mechanical or hand tampers, weighing not less than 20 pounds, or vibratory rollers. All other means must be approved in writing by the Engineer. All backfill shall be compacted to 95% of maximum laboratory dry density or 70 percent relative density. The material shall be within 2.0 percent of optimum moisture content. Finished backfill surface shall be proof rolled and exhibit no deflections.

The Developer may request approval of alternate means of compaction. Such request must be submitted from a registered engineer to the Town in writing. Approval of the compaction method will be made by the Town only in writing. Use of specified or approved compaction methods does not relieve the Developer from providing a completed project meeting the intent of this Specification.

- d. Maintenance of Backfill. All backfill shall be maintained in a satisfactory condition and all places (including pavement) showing signs of settlement shall be filled and maintained for a period of two years following the date of final acceptance of all work performed. When the Developer discovers or is notified by the Engineer or the Town that

any backfill is not in compliance with these requirements, the Developer shall correct such condition at once. Any utilities and road surfacing damaged by such settlement shall be repaired by the Developer to the satisfaction of the Town and Engineer. In addition, the Developer shall be responsible for the cost to the Town of all claims for damages filed with the Court and actions brought against the said Town for, and on account of, such damage.

- e. Dewatering. All pipe trenches shall be kept free from water during pipe installation and other related work. The method of dewatering shall provide for a completely dry trench bottom. Dewatering shall be accomplished by the use of well points, sump pumps, rock or gravel drains placed below subgrade or subsurface pipe drains. All water shall be disposed of in a suitable manner without being a menace to public health or causing public inconvenience. No water shall be drained into other work being completed or under construction. The dewatering operation shall continue until such time as it is safe to allow the water table to rise in the excavation. Pipe trenches shall contain enough backfill to prevent pipe flotation.
- f. Trench Sub-grade in Poor Soils. In excessively wet, soft, spongy, unstable or similarly unsuitable material is encountered at the surface upon which the bedding material is to be placed, the unsuitable material shall be removed to a depth as determined in the field by the Town or it's designated representative and replaced with Trench Stabilization material.

3.5 TESTING

3.5.1 Sanitary Sewer Line Testing

The following testing procedures are intended to determine if the sanitary sewer line meets the Town's minimum quality standards. Alternative procedures meeting or exceeding the intent of these procedures, as determined by the Town's Engineer, may be acceptable. In any case, however, proposed alternative testing procedures must be included in the design plans and specifications.

The Contractor shall notify the Town's Inspector - no less than 48 hours prior to the desired test time.

The Town's Inspector shall witness all tests and verify the accuracy and acceptability of the equipment utilized. The Town's Engineer will inform the Contractor regarding acceptable methods of repair in the event that one or more sections fail to pass any test.

3.5.1.1 Pipeline Flushing

The Contractor shall flush the pipelines, as the work progresses by means that are in accordance with good practice, to insure that earth, sand, rocks or other foreign materials are removed from the interior of the pipeline. Proper environmental and erosion control

prevention measures shall be employed meeting CDPHE latest Standards and Regulations.

3.5.1.2 Alignment and Grade

Sewer pipelines will be checked by the Town to determine whether any displacement of the pipe has occurred after the trench has been bedded. The test will be as follows:

A light will be flashed between manholes, or if the manholes have not as yet been constructed, between the locations of the manholes, by means of a flashlight or by reflecting sunlight with a mirror. If the illuminated interior of the pipelines shows poor alignment, displaced pipe, earth, or other debris in the pipe, or any other kinds of defects, the defects, determined by the Town, shall be remedied by the Contractor. The test will be repeated following completion of backfilling and any poor alignment, displaced pipe, or other defects, determined by the Town, shall be corrected at no cost to the Town.

3.5.1.3 Leakage Testing by Exfiltration

Tests for water tightness shall be made by the Contractor in the presence of the Town's Inspector. The Contractor shall provide assistance to the Town's Inspector in development of a detailed record of the testing program. The sewer and connections shall not leak in excess of the following rate for a 24-hour test period:

MAXIMUM ALLOWABLE SEWER LEAKAGE	
Pipe Size Inches	Leakage Gal/Foot/24 Hours
18	0.68
15	0.57
12	0.45
10	0.38
8	0.30
6	0.23

Each reach of pipeline between manholes shall be tested individually. Any individual reach that leaks in excess of the amount allowed in the previous paragraph shall be considered as failing, and shall be repaired and retested.

At the discretion of the Town, the time for leakage rate test may be shortened to four (4) hours.

The tests and measurement of infiltration or exfiltration shall be conducted in a manner approved by the Town's Inspector. The minimum head for the exfiltration tests shall be 2 feet above the top of the pipe at its highest point in the test section. Sections shall be bulk-headed so that during any test the head on the sewer at its lowest elevation will not be more than 10'. This restriction does not apply to ductile-iron pipe.

The Contractor shall repair the sewer in a manner that is satisfactory to the Town and re-test at the contractors' expense until a satisfactory installation is obtained.

3.5.1.4 Leakage Testing by Infiltration

Infiltration tests will be used if the groundwater table is likely to be 1 foot or more above the invert of the finished sewer. Otherwise, exfiltration tests will be used. The allowable leakage rates are as tabulated for section 3.5.1.3, Leakage Testing by Exfiltration.

3.5.1.5 Low-Pressure Air Test

At the option of the Contractor, low-pressure air testing of the installed sewer pipe may be used instead of the leakage exfiltration test.

The following criteria and procedure shall be utilized, unless otherwise approved by the Town's Inspector.

- 1) Plug Restraint. It is extremely important and essential that all plugs be installed and braced in such a way that blowouts are prevented. It is recommended that every plug be positively braced and that no one be allowed in the manhole adjoining a line being tested so long as pressure is maintained in the line.
- 2) Relief Valve. All pressurizing equipment used for low-pressure air testing shall include a regulator or relief valve set no higher than 9 psig to avoid over pressurizing and displacing temporary or permanent plugs. As an added safety precaution, the pressure in the test section should be continuously monitored to make certain that it does not at any time exceed 9 psig.
- 3) Plug Design. Either mechanical or pneumatic plugs may be used. All plugs shall be designed to resist internal testing pressures without the aid of external bracing or blocking. However, the Contractor should internally restrain or externally brace the plugs to the manhole wall as an added safety precaution throughout the test.
- 4) Singular Control Panel. To facilitate test verification by the inspecting Engineer, all air used shall pass through a single, above ground control panel.
- 5) Equipment Controls. The above ground air control equipment shall include a shutoff valve, pressure regulating valve, pressure relief valve, input pressure gauge, and a continuous monitoring pressure gauge having a pressure range from 0 to at least 10 psi. The continuous monitoring gauge shall be no less than 4 inches in diameter with minimum divisions of 0.10 psi and an accuracy of 0.04 psi.

- 6) Separate Hoses. Two separate hoses shall be used to: (1) connect the control panel to the sealed line for introducing low-pressure air, and (2) a separate hose connection for constant monitoring of air pressure build-up in the line. This requirement greatly diminishes any chance for over-pressurizing the line.
- 7) Pneumatic Plugs. If pneumatic plugs are utilized, a separate hose shall also be required to inflate the pneumatic plugs from the above ground control panel.
- 8) Laterals, Stubs, and Fittings. During sewer construction all service laterals, stubs, and fittings into the sewer test section shall be properly capped or plugged so as not to allow air loss that could cause an erroneous air test result. It may be necessary and is always advisable to restrain gasketed caps, plugs, or short pipe lengths with bracing stakes, clamps and tierods, or wire harnesses over the pipe bells.
- 9) Plug Installation and Testing. After manholes have been tested for alignment and grade, and a manhole-to-manhole reach of pipe has been backfilled to final grade and prepared for testing, the plugs shall be placed in the line at both manholes and secured.

It is advisable to seal test all plugs before use. Seal testing may be accomplished by laying one length of pipe on the ground and sealing it at both ends with the plugs to be checked. The sealed pipe should be pressurized to 9 psig. The plugs shall hold against this pressure without bracing and without any movement of the plugs out of the pipe. No persons shall be allowed in the alignment of the pipe during plug testing.

The upstream end of the line shall be plugged first to prevent any upstream water from collecting in the test line.

- 10) Line Pressurization. Low pressure air shall be slowly introduced into the sealed line until the internal air pressure reaches 4.0 psig.
- 11) Pressure Stabilization. After a constant pressure of 4.0 psig is reached, the air supply shall be throttled to maintain that internal pressure for at least 2 minutes. This time permits the temperature of the entering air to equalize with the temperature of the pipe wall.
- 12) Timing Pressure Loss. When temperatures have been equalized and the pressure stabilized at 4.0 psig, the air hose from the control panel to the air supply shall be shut off or disconnected. The continuous monitoring pressure gauge shall then be observed while the pressure is decreased to no less than 3.5 psig. The timing pressure loss test shall then commence at

a pressure reading of 3.5 psig, or any convenient observed pressure reading between 3.5 psig and 4.0 psig. (Except as adjusted for groundwater as follows.)

- 13) Air Pressure Adjustment. An air pressure correction, which must be added to the 3.5 psig normal test starting pressure, shall be calculated by dividing the average vertical height, in feet of groundwater above the invert of the sewer pipe to be tested, by 2.31. The result gives the air pressure correction in pounds per square inch to be added. (For example, if the average vertical height of groundwater above the pipe invert is 2.8 feet, the additional air pressure above the pipe invert is 2.8 divided by 2.31 or 1.2 psig. This would require a minimum starting pressure of 3.5 plus 1.2 or 4.7 psig). The allowable pressure drop of 1.0 psig and the timing in Table I are not affected and shall remain the same. In no case however should the starting test pressure exceed 9.0 psig.
- 14) Determination of Line Acceptance. If the time shown in Table I for the designated pipe size and length, elapses before the air pressure drops 1.0 psig, the section undergoing test shall have passed.

**TABLE 1
SPECIFICATION TIME REQUIRED FOR A 1.0 PSIG PRESSURE DROP
FOR SIZE AND LENGTH OF PIPE INDICATED FOR Q = 0.0015**

1 (min:sec) Pipe Diameter (in.)	2 Minimum Time (min:sec)	3 Length for Minimum Time (ft)	4 Time for Longer Length (sec)	100 ft	150 ft	200 ft	250 ft	300 ft	350 ft	400 ft	450 ft
4	3:46	597	.380 L	3:46	3:46	3:46	3:46	3:46	3:46	3:46	3:46
6	5:40	398	.854 L	5:40	5:40	5:40	5:40	5:40	5:40	5:42	6:24
8	7:34	298	1.520 L	7:34	7:34	7:34	7:34	7:36	8:52	10:08	11:24
10	9:26	239	2.374 L	9:26	9:26	9:26	9:53	11:52	13:51	15:49	17:48
12	11:20	199	3.418 L	11:20	11:20	11:24	14:15	17:05	19:56	22:47	25:38
15	14:10	159	5.342 L	14:10	14:10	17:48	22:15	26:42	31:09	35:36	40:04
18	17:00	133	7.692 L	17:00	19:13	25:38	32:03	38:27	44:52	51:16	57:41

3.5.1.6 Deflection

All PVC sewer pipelines shall be tested for vertical deflection after placement and compaction of backfill unless testing is specifically excepted by the Town's Inspector. Method of testing shall be by deflectometer of the rigid GO/NO-GO type device. Alternative methods will be permitted only by written permission of the Town's Inspector. Maximum allowable deflection shall be five (5) percent of the pipe diameter.

Any and all pipe with vertical deflection greater than the allowable shall be excavated, removed from the pipeline, replaced, backfilled and compacted as specified and retested.

The Town reserves the right to direct the Developer to retest sewer lines after 10-12 months of service, if the Town has concerns about the condition of certain sections of pipe. Sections would be selected for retesting based on the results of the initial tests, the outcome of the television inspection (per Section 3.5.3), depth of cover, or other technical factors. The Developer shall perform such retesting at no cost to the Town.

3.5.2 Manholes

During the construction of the manholes, the Contractor shall, in accordance with good practice, ensure that no earth, sand, rocks or other foreign material exists on the joint surface during assembly of the sections. The Town's Inspector shall check each manhole to determine whether the manhole fulfills the requirements of the Drawings and Town's Standards.

3.5.2.1 Visual Examination

The Town shall visually check each manhole, both exterior and interior, for flaws, cracks, holes, or other inadequacies which might affect the operation or watertight integrity of the manhole. Should any inadequacies be found, the Contractor shall make any repairs deemed necessary by the Town's Inspector.

3.5.2.2 Leakage Test

All manholes shall be tested for leakage and all tests shall be witnessed by the Town's Inspector. The leakage test shall be conducted prior to backfilling around the manhole and shall be carried out in the following manner:

- 1) All lines leading into or out of the manhole shall be tightly plugged
- 2) The manhole shall be filled with water to a level at least 2 inches above the uppermost step. The water shall be allowed to stand for two hours to allow for normal water absorption into the manhole material. At the end of the two-hour stabilization period, if the water level in the manhole has dropped below the top step, additional water will be added to bring the level above the step as before. Any visible external leakage or drop in water level noted within the one-hour test period shall constitute failure and the Contractor shall repair or replace the defective work and retest.
- 3) Vacuum Testing. At the option of the Contractor, vacuum testing of the installed manholes may be used instead of the leakage test. All pipes entering and exiting the manhole shall be temporarily plugged, taking care to securely brace the pipes and plugs to prevent them from being drawn into the manhole.

The test head shall be placed at the top of the manhole and the seal inflated in accordance with the manufacturer's recommendations.

A vacuum of 10-inches of mercury shall be drawn on the manhole, the valve on the vacuum line of the test head shall be closed, and the vacuum pump shut-off. The time shall be measured for the vacuum to drop to 9-inches of mercury.

The manhole will be declared unacceptable if the time to drop from 10-inches of mercury to 9-inches of mercury is less than 60 seconds. This test interval is valid for 48" MH of up to 24' depth, 60" MH up to 18' deep and 72" MH up to 14' deep. The Town Engineer will establish test intervals for other situations on a case-by-case basis.

3.5.3 Television Inspection

The Developer shall perform television inspections of each segment of the sewer line and record this inspection on a CD, which is to be turned over to the Town. The format for labeling and stationing of this record is to be approved by the Town prior to performing the TV inspection. The Developer is to provide a one week notice prior to the TV inspection, so that a representative from the Town may be present to observe the inspection in progress. There shall be two TV inspections performed, one at the initial acceptance and one at the end of the two year warranty. The warranty inspection is to be performed no earlier than 22 months after acceptance of the sewer construction by the Town. The CD is to be submitted to the Town no later than 23 months after the date of Town acceptance. Performance of the two TV video inspections shall be completed at no cost to the Town.

3.5.4 Water Main Testing

All finished water lines, after reaction blocking is in place, shall be pressure and leakage tested at not less than 150 psi for a two-hour period. If working pressure is greater than 100 psi, the test shall be performed at 1.5 times the expected working pressure. Unless approved by the Engineer no lines longer than 1200' shall be tested at one time.

No pipeline installation will be acceptable until the leakage is less than the amount computed by the following formula:

$$L = \frac{SD(P)^{0.5}}{133,200}$$

Where:

L = Allowable leakage in gallons (per hour)

S = Tested length of pipe (feet)

D = Nominal diameter of pipe, inches

P = Average test pressure during the test, psi

3.5.5 Water Main Disinfection

All water piping shall be disinfected in accordance with AWWA C601 after all construction work has been completed. Chlorine shall be added to the water at the necessary locations in the amount to form a 50-ppm free chlorine residual. The chlorine solution shall be left in the pipelines for not less than 24 hours, during which time all valves and fire hydrants shall be operated in order to disinfect the appurtenances. After that length of time, the chlorine residual of the solution, at any place in the system, shall not be less than 10 ppm. All chlorination work must be done in the presence of the Engineer. At the end of 24 hours, a bacteriological test is to be performed by the local health authority to ensure adequate disinfection, at the cost of the Developer. Special provisions (at no additional cost to the Town) must be made to ensure any highly chlorinated water is not discharged to the ground. The Developer must submit the "method of disposal" for this chlorinated water prior to any testing.

SECTION 4
SERVICE LINE STANDARDS

SECTION 4

SERVICE LINE STANDARDS

4.1 GENERAL

No service line may be constructed without prior approval from the Town. The Applicant must provide adequate information describing the nature of the building or development to be connected, the proposed service line size, and the proposed connection point of the service line to the main. A site plan, showing the location of the proposed service line relative to other utilities on and adjacent to the property must be presented. The drawing must show the location of buildings served and parts of the site that are to be paved or otherwise intended to be kept clear of snow, and must also show service line slope and depth of cover over the service line.

The sizing of the service lines shall be the responsibility of the Applicant. When requested by the Town, the Applicant shall, at his expense, furnish data, plans, calculations, or other information as required for the evaluation of the service size. Service lines are the responsibility of the Developer or Applicant, who is responsible for design and construction and the costs thereof and for payment of actual costs of review and inspection provided by the Town.

All service lines are to be constructed in accordance with applicable codes, generally accepted good construction practices, and the minimum standards and criteria contained in this document. The details are provided for standardization purposes only, and represent minimum design standards which may require upgrading for specific applications.

No water service line shall be connected to a main which has not been pressure tested, disinfected and accepted by the Town.

4.2 OWNERSHIP AND MAINTENANCE

Ownership and maintenance responsibilities are defined under the following categories of Sewer Service, New Single-Family Detached Residential Water Service, Existing Single-Family Detached Residential Water Service and Commercial/Multifamily Water Service.

Sewer Service: The sewer service line is defined as beginning at the wye connection of the main line to the point of connection to the building(s) and is the property of the customer of the resident, unit or building served (see Drawing L1). Repairs, maintenance cleanings and pipe replacement of the service line are the responsibility of the customer.

New Single Family Detached Residential Water Service: A new single family detached residential water service is defined as a service constructed on or after January 1, 2011 in accordance with these standards and the details shown on Drawing L4. Starting at the property line the customer shall own and be responsible for maintenance and replacement of the service line and appurtenances including the stop and waste valve (curb stop), buried piping, internal piping, meter and meter box, valves, PRV and backflow preventer to the premise served. The stop and waste valve (curb stop) and meter box shall be located in a convenient, accessible

location and kept in good working order and clean of debris. Any meter or valve box not conforming to these maintenance standards shall be cleaned, repaired or replaced by the property owner. Failure by the property owner to comply may cause the Town to complete the required maintenance with the costs thereof billed to the owner. In addition, the Property Owner shall be responsible for the thawing of frozen service lines and appurtenances starting at the stop and waste valve to the premise served.

Existing Single Family Detached Residential Water Service: An existing single family detached residential water service is defined as a service constructed before January 1, 2011. If a property has a stop and waste valve located and installed in accordance with the details on Drawing L4, the customer, starting at the property line, shall own and be responsible for maintenance and replacement of the service line and appurtenances including the stop and waste valve (curb stop), buried piping, internal piping, meter and meter box, valves, PRV and backflow preventer to the premise served.

If a property does not have a private water system in accordance with the detail shown on Drawing L4, the service shall be considered non-conforming. Any repairs to a non-conforming water service line shall require the installation of a stop and waste valve A Pressure Reducing Valve (PRV) is not required at the time of the stop and waste installation; however, it is the responsibility of the property owner to maintain proper operating water pressures for individual water service. If a property has a non-conforming water system, the property owner shall own and be responsible for maintenance and replacement of the service line, and appurtenances including the corporation stop, stop and waste valve (curb stop), buried piping, internal piping, meter and meter box, valves, PRV and backflow preventer from the premise served to the corporation stop on the main line.,

The stop and waste valve and meter box shall be located in a convenient, accessible location and kept in good working order and clean of debris. Any meter or valve box not conforming to these maintenance standards shall be cleaned, repaired or replaced by the property owner. Failure by the property owner to comply may cause the Town to complete the required maintenance with the costs thereof billed to the owner.

The Town, depending on the on extent of ownership, shall be responsible for the replacement of Town improvements such as sidewalks, curb & gutter and roadway in repairing or replacing any service line (the replacement of private landscaping and fencing is not included). For non-conforming services, the property owner will be responsible for all Town improvement costs associated with a service repair or replacement.

The Town will not be responsible for the thawing of frozen service lines under private ownership.

Commercial/Industrial/Multifamily Water Service: Each individual Commercial or Industrial structure or Multifamily unit shall be served by separate service lines. At the discretion of the Town, depending on unit ownership, single lines serving Multifamily units may be allowed.

Typically separate lines shall be installed for fire suppression systems. The Town may allow combined service lines for potable use and fire suppression. Potable services must be isolated and protected from the fire suppression system as per these Standards defined in Section 5. . The Town assumes no obligation for the adequacy of private fire protection systems.

Water services ownership begins at the stop and waste valve if one is installed; or at the isolation valve if there is no stop and waste valve; or at the corporation stop on the mainline if there is no isolation valve or stop and waste valve. Starting at the point of ownership (corporation stop, isolation valve, or stop and waste valve) the customer shall own and be responsible for maintenance and replacement of the service line and appurtenances included buried piping, internal piping, meter and meter box or vault, valves, PRV and backflow preventer. The meter or meter box/vault shall be located in a convenient, accessible location and kept in good working order and clean of debris. Any meter or vault not conforming to these maintenance standards shall be cleaned, repaired or replaced by the property owner. Failure by the property owner to comply may cause the Town to complete the required maintenance with the costs thereof billed to the owner. In addition, the Town will not be responsible for the thawing of frozen lines and appurtenances under private ownership.

4.3 SERVICE CONNECTION

No connection between the sewer or water system of the Town and the service of the owner may be made except in a public street adequate to accommodate the sewer or water facilities or in a similar place to which the Town has as a free right of access as it would have in a public street.

Where parallel or approximately parallel to a structural wall, the service shall be at least 5' from the wall. Penetrations through structures shall be approximately at right angles and shall provide flexibility such that the service will not be damaged by settlement of the structures.

Water and sewer service lines shall have 10 feet minimum of horizontal separation. Where this separation is impractical, the Town may permit other separation requirements, in accordance with applicable standards. If a sewer service line passes over a water main or service, or if it lies within 10 feet of the water main or service, the service is to be modified as specified in Drawing G3.

The minimum cover shall be 6 feet from top of sewer service line to finished grade and 5 feet from top of water service line to finish grade.

The applicant for a service shall notify the Town when the service line is ready for connection to the public sewer or water main, and the connection shall not be made until after inspection and approval by the Town. The service line shall meet the requirements of the International Plumbing Code (IPC). The connection to the main shall be made in the presence of and approved by the Town Inspector. The trench of each service line must be open (not backfilled) from the building to the tap, to allow inspection by the Town prior to backfilling.

If practicable, pre-installed wye fittings shall be used for sewer service connections; otherwise the connection of the building sewer service to the main shall be made as follows: A saddle tee

shall be used to connect 4" or 6 sewer service lines to 8" to 15" sewer mains. No saddle wyes are allowed. The service line connection shall conform to the Drawing L1. To simplify later location of service connection points in plastic pipe, bury 1-2 pound piece of magnetic material within 12" of the joint and approx. 12" above.

Each sewer service line is to have a 4" cleanout installed within 20' of the building served, per Drawing L2. Cleanouts are required for any significant change in service line direction and at intervals of no greater than 90'.

Water services lines shall be laid at a uniform grade and in straight alignment. A reference mark shall be placed on the curb above the line.

4.4 SEWER SERVICE SIZING

The size and slope of the building service sewer shall be subject to the approval of the Town, but in no event shall the diameter be less than 4". Minimum grade and slopes shall be as follows:

4"	2.0% Normal, 1.0% Minimum
6"	1.00%
8"	0.60%

4.5 WATER SERVICE SIZING

Sizing. Sizing for potable water services shall be made in general conformance with AWWA Manual M22, "Sizing Water Service Lines and Meters." When requested by the Town, the Applicant shall, at his expense, furnish data, plans, calculations, or other information as required for the evaluation of the service size.

Cross Connections. Cross connections of any type that permit a backflow condition from any source other than the Town's potable water mains are prohibited. The Town will not provide water service to any customer unless the potable water supply is protected from potential or actual cross connections as required in Section 5. . Each service shall include an approved back flow prevention device. All water services larger than 1-inch and all fire suppression systems shall include an approved backflow prevention device as defined in Section 5.

Pressure Regulation. A pressure reducing valve (PRV) is recommended. It is the responsibility of the property owner to maintain proper operating pressures, commonly not exceeding 70 psi, for the individual water service. If a PRV is installed, it shall be located upstream of all uses.

4.6 SEWER SERVICE MATERIALS AND INSTALLATION

Sewer service pipe shall be PVC, with a thickness not less than SDR 35. Sanitary Sewer Service Pipe shall be green or other acceptable color.

The line shall be water tight and on a constant grade in a straight line, and not closer than 5' from any bearing wall.

4.7 WATER SERVICE MATERIALS

Water Service Pipeline: The water service pipeline shall be Type K, soft copper conforming to ASTM 888, unless otherwise specifically approved by the Town. Fittings shall be brass or copper alloy. Connections shall be by flared joints and no soldered joints shall be permitted underground.

Corporation Stops: Corporation stops shall be used for the connection of services (2- inch and smaller) to the water main. Corporation stops shall be brass and conform with AWWA C800. The inlet shall be standard AWWA corporation stop inlet thread and the outlet shall be for compression type "K", 1" or less, copper service pipe. Corporation stops shall be Mueller H-15000, Ford F-600, or approved equal, provided with an insulating coupling for potable service.

Curb Stops: Curb stops (sometimes called "stop & waste boxes") shall be provided as detailed on Drawing L3 for all services. Curb stops shall be brass and conform with AWWA C800. Connections shall be for compression type " K copper service pipe. Curb stops shall be Mueller H-15204, Ford 8-22, or approved equal.

Service Saddles: Service saddles shall be used for all water taps on any pipe other than DIP (Ductile Iron Pipe). For DIP, 3/4" and 1" taps may be made without using a service saddle on pipe 8" mains or larger. All other DIP taps shall be made with a double strap bronze saddle, Smith Blair No. 357, Rockwell No. 323 or approved equal.

Meters. Unless otherwise approved, water meters shall be housed in an exterior meter pit in accordance with the standard drawings. Meters shall be bronze case Sensus SR-II TR/LP with sealed register and touch read/pit lid adapters. Meter shall be set with a coppersetter having an integral angle curb valve on the inlet side. Coppersetter shall be Ford 80 series or approved equal.

Meter Pits. Meter pits shall be pre-cast polyethylene with minimum nominal wall thickness of 0.55-inches, vertical crush strength exceeding 20,000 lbs, white interior color and black exterior color manufactured by Mid-States Plastics or approved equal. Concrete pits (H20 traffic load rating) with stackable section is also acceptable.

Meter Pit Covers. Covers shall be constructed of cast iron with rubber or plastic inner frost lid. The top lid shall include a worm type lock operated by a pentagon head. The lid and cover shall be Ford Wabash No. W3 or approved equal. The top lid shall be tapped for mounting the touch read pad. Radio transmitting units maybe required by the Town. Pit locations in driveways and alleyways shall have covers rated for H20 traffic loading.

4.8 WATER SERVICE INSTALLATION

The service line connection shall be constructed as shown in Drawing L4.

All excavations for water service installations shall be adequately guarded with barricades and lights so as to protect the public from hazards. Utilities, streets, sidewalks, parkways, and other public or private property disturbed in the course of work shall be restored to their original condition in a manner satisfactory to the Town of Elizabeth or other affected owners or jurisdictions.

All excavations required for the installations of a water service shall be open-trench work, unless otherwise approved by the Town. The services shall be bedded and backfilled in accordance with the minimum cover and/or insulation requirements of Section 3. The bedding and pipe zone material within 12" of the water service line shall be select native soils with 3" max. diameter rock. Backfill materials shall be select native soils with 6" maximum diameter rock. If insulation is installed, use approximately 6" of sand or squeegee for the pipe zone materials above and beneath the insulation to protect it from breakage during backfill.

4.9 DOCUMENTATION

The Applicant shall submit a dimensioned sketch to the Town, showing the location of the point of connection, relative to visible and reasonably permanent surface features, such as building corners, property pins or power flight poles. As-built drawings of the entire system, including curb-stops, shall be required at system dedication and pursuant to the Town's Municipal Code.

SECTION 5
BACKFLOW PREVENTION AND
CROSS-CONNECTION CONTROL

SECTION 5

BACKFLOW PREVENTION AND CROSS-CONNECTION CONTROL

5.1 Purpose.

The purpose of backflow prevention and cross-connection control is to protect the Town of Elizabeth public potable water supply from the possibility of contamination or pollution by isolating or containing within the consumer's internal distribution system(s) or the consumer's private water system(s) such contaminants or pollutants that could backflow into the public water system; To promote the elimination or control of existing cross connections, actual or potential, between the consumer's in-plant/in-house potable water system(s) and non-potable water systems, plumbing fixtures, and industrial piping systems; and To provide for the maintenance of a continuing program of cross-connection control that will systematically and effectively prevent the contamination or pollution of the potable water system.

5.2 Definitions.

The definitions of terms used in this section are those contained in the Colorado Department of Health and Environment's Cross Connection Control Manual as the same may be amended from time to time, unless otherwise defined below:

"Active date" means the first day that a backflow prevention assembly or backflow prevention method is used to control a cross-connection in each calendar year.

"Air gap" is a physical separation between the free flowing discharge end of a potable water supply pipeline and an open or non-pressure receiving vessel installed in accordance with standard AMSE A112.1.2.

"Approved Backflow Device" A backflow device or air gap meeting the standards and installation requirements of the A.S.S.E. (American Society of Sanitary Engineers), the latest edition of the Colorado Department of Health and Environment's Colorado Cross Connection Control Manual and/or the requirements of these standards. Approval by the Town will be dependent upon the hazard(s) assessed, but shall not be less than the Colorado Department of Health and Environment's Colorado Cross Connection Control Manual requirements for potable water system protection. "Approved" status shall also be contingent on inspection, testing and passing of such test by a Certified Cross Connection Control Technician. Any variation or exception may be by direction from the current edition of the Colorado Department of Health and Environment's Colorado Cross Connection Control Manual.

"Backflow" means the undesirable reversal of flow of water or mixtures of water and other liquids, gases or other substances into the public water distribution system from any source or sources other than its intended source.

"Backflow contamination event" means backflow into the public water system from an uncontrolled cross connection such that the water quality no longer meets the Colorado primary Drinking Water Regulations or presents an immediate health and/or safety risk to the public.

“Backflow prevention assembly” means any mechanical assembly installed at a water service line or at a plumbing fixture to prevent a backflow contamination event, provided that the mechanical assembly is appropriate for the identified contaminant at the cross connection and is an in-line field-testable assembly.

“Backflow prevention method” means any method and/or non-testable device installed at a water service line or at a plumbing fixture to prevent a backflow contamination event, provided that the method or non-testable device is appropriate for the identified contaminant at the cross connection.

“Certified cross-connection control technician” means a person who possesses a valid Backflow Prevention Assembly Tester certification from one of the following approved organizations: American Society of Sanitary Engineering (ASSE) or the American Backflow Prevention Association (ABPA). If a certification has expired, the certification is invalid.

“Containment” means the installation of a backflow prevention assembly or a backflow prevention method at any connection to the public water system that supplies an auxiliary water system, location, facility, or area such that backflow from a cross connection into the public water system is prevented.

“Containment by isolation” means the installation of backflow prevention assemblies or backflow prevention methods at all cross connections identified within a customer’s water system such that backflow from a cross connection into the public water system is prevented.

“Controlled” means having a properly installed, maintained, and tested or inspected backflow prevention assembly or backflow prevention method that prevents backflow through a cross connection.

“Cross connection” means any connection that could allow any water, fluid, or gas such that the water quality could present an unacceptable health and/or safety risk to the public, to flow from any pipe, plumbing fixture, or a customer’s water system into a public water system’s distribution system or any other part of the public water system through backflow.

“Multi-family” means a single residential connection to the public water system’s distribution system from which two or more separate dwelling units are supplied water

“Service Connection” The terminal end of the water supplier service connection from the Town’s potable water distribution system to the threads on the curb stop if present, or corporation stop on water main line, where the Water Department loses jurisdiction and sanitary control and consumer ownership begins. “Service connection” shall also include water service connection from a fire hydrant and all other temporary or emergency water service connections from the Town’s potable water system.

“*Single-family*” means:

- i. A single dwelling which is occupied by a single family and is supplied by a separate service line; or
- ii. A single dwelling comprised of multiple living units where each living unit is supplied by a separate service line.

“*Uncontrolled*” means not having a properly installed, maintained and tested or inspected backflow prevention assembly or backflow prevention method, or the backflow prevention assembly or backflow prevention method does not prevent backflow through a cross connection.

“*Thermal Expansion*” Increase in linear dimensions of a solid or in volume of a fluid because of rise in temperature

“*Water supply system*” means a water distribution system, piping, connection fittings, valves and appurtenances within a building, structure, or premises. Water supply systems are also referred to commonly as premise plumbing systems.

5.3 Authority.

- (1) The authority for the Town to implement this program is contained in the following statute, legislation and regulations and acts:
 - a. Article 1-114 and Article 1-114.1 of Title 25 of the Colorado Revised Statutes (CRS)
 - b. Section 39 of 5 CCR 1002-11, Colorado Primary Drinking Water Regulations (Regulation 11) Effective date May 1, 2015
 - c. Colorado Plumbing Code
 - d. International Plumbing Code

The Town shall have the authority to survey all service connections within the distribution system to determine if the connection is a cross-connection.

The Town shall have the authority to control all service connections within the distribution system if the connection is a cross-connection.

The Town may control any service connections within the distribution system in lieu of a Cross Connection Survey as long as the service connection is controlled with a Reduced Pressure Zone (RPZ) backflow prevention assembly that is annually tested.

The Town may collect fees for the administration of this program.

The Town shall maintain records of cross-connection surveys and the installation, testing and repair of all backflow prevention assemblies installed for containment and containment by isolation purposes.

Except as otherwise provided herein, the Town shall administer, implement and enforce the provisions of this Section.

5.4 Applicability.

This Section applies to all commercial, industrial and multi-family residential service connections (Non-Single Family Residential) within the Town water system and to any persons outside the Town who are, by contract or agreement with the Town, users of the Town water system. This Section may apply to single-family-residential service connections if the Town becomes aware of, or suspects a possible cross connection at the single family connection.

5.5 General Policy.

The Town shall be responsible for the protection of the Town's potable water distribution system from contamination or pollution due to the backflow of contaminants or pollutants through water service connections. If, in the judgment of the Town, an approved backflow-prevention assembly is required at the consumer's water service connection; or, within the consumer's private water system for the safety of the water system, the Town shall give notice in writing to said consumer to install such an approved backflow prevention assembly(s) at specific location(s) on his/her premises. The consumer shall install such approved assembly(s) within the time frame set forth in the notice and at his/her own expense; and, failure, refusal, or inability of the consumer to install, have tested, and maintain said assembly(s) shall constitute grounds for discontinuing water service to the premises until such requirements have been satisfactorily met.

5.6 Requirements.

- (a) Commercial, industrial and multi-family service connections shall be subject to a survey for cross connections. If a cross connection has been identified an appropriate backflow prevention assembly and or method shall be installed at the customer's water service connection within 120 days of its discovery. The assembly shall be installed downstream of the water meter or as close to that location as deemed practical by the Town. If the assembly or method cannot be installed within 120 days the Town must take action to control or remove the cross connection, suspended service to the cross connection or receive an alternative compliance schedule from the Colorado Department of Public Health and Environment. At the consumers expense all new connections requiring a backflow device shall be inspected and tested by a Certified Cross Connection Control Technician.
- (b) Changes in Service. Any changes in service including, but not limited to, reconnection, change in the number of fixture values, or change in the type of water service, shall require installation of an approved backflow device.

In no case shall it be permissible to have connections or tees between the meter and the containment backflow prevention assembly. In instances where a reduced pressure principle backflow preventer cannot be installed, the owner must install approved backflow prevention devices or methods at all cross-connections within the owner's plumbing system.

- (c) Backflow prevention assemblies and methods shall be installed in a location which provides access for maintenance, testing and repair.
- (d) Reduced pressure principle backflow preventers shall not be installed in manner subject to flooding.
- (e) Provisions shall be made to provide adequate drainage from the discharge of water from reduced pressure principle backflow prevention assemblies. Such discharge shall be conveyed in a mater which does not impact waters of the state.
- (f) All assemblies and methods shall be protected to prevent freezing. Those assemblies and methods used for seasonal services may be removed in lieu of being protected from freezing. The assemblies and methods must be reinstalled and then tested by a certified cross-connection control technician upon reinstallation.
- (g) Where a backflow prevention assembly or method is installed on a water supply system using storage water heating equipment such that thermal expansion causes an increase in pressure, a device for controlling pressure shall be installed.
- (h) All backflow prevention assemblies shall be tested at the time of installation and on an annual schedule thereafter. Such tests must be conducted by a Certified Cross-Connection Control Technician.
- (i) The Town shall require inspection, testing, maintenance and as needed, repairs and replacement of all backflow prevention assemblies and methods, and of all required installations within the owner's plumbing system in the cases where containment assemblies and or methods cannot be installed.
- (j) All costs for design, installation, maintenance, testing and as needed repair and replacement are to be borne by the customer.
- (k) No grandfather clauses exist except for fire sprinkler systems where the installation of a backflow prevention assembly or method will compromise the integrity of the fire sprinkler system.
- (l) New water system connection and/or new building to the Town water system must have the following: plans submitted to the public water system and approved prior to the issuance of water service. Building plans must show:
 - 1) Water service type, size and location
 - 2) Meter size and location
 - 3) Types of water use at the property
 - 4) Backflow prevention assembly size, type and location

- 5) Fire sprinkler system(s) service line, size and type of backflow prevention assembly.
 - a) All fire sprinkling lines shall have a minimum protection of an approved double check valve assembly for containment of the system.
 - b) All glycol (ethylene or propylene), or antifreeze systems shall have an approved reduced pressure principle backflow preventer for containment.
 - c) Dry fire systems shall have an approved double check valve assembly installed upstream of the air pressure valve.
 - d) In cases where the installation of a backflow prevention assembly or method will compromise the integrity of the fire sprinkler system the Town can chose to not require the backflow protection. The Town will measure chlorine residual at a location representative of the service connection once a month and perform periodic bacteriological testing at the site. If the Town suspects water quality issues the Town will evaluate the practicability of requiring that the fire sprinkler system be flushed periodically.
 - e) At the consumers expense all new connections requiring a backflow device shall be inspected and tested by a Certified Cross Connection Control Technician.
 - f) Variance. Upon written application by the consumer to the Colorado Department of Public Health and Environment (CDPHE) Water Quality Control Division (WQCD), the Town may vary from this requirement.

5.7 Installation.

Installation of backflow prevention assembly in compliance with this Section is a condition to receiving water service from the Town. All connections to the municipal water system, including all existing connections, shall conform or be brought into conformance with the following requirements:

- a. Backflow prevention assemblies installed in violation of this Section shall be removed and replaced at the water customer's expense. Any such repair or replacement shall be made with an approved backflow prevention assembly within ten (10) days of discovery by the user, a certified technician, or the Town and/or its designee, unless arrangements satisfactory to the Town are made. Should the hazard presented to the water system be determined to present a significant health risk, immediate service discontinuance may be necessary until such repair or replacement is accomplished.
- b. Backflow prevention assemblies shall be installed in a safe and accessible location to facilitate maintenance, testing, repair and drainage in accordance with all applicable codes and regulations. No backflow prevention assembly shall be installed in a pit, vault or location where toxic gases are present. No backflow prevention assembly shall be installed over electrical lines or other equipment where water could cause a hazard.

- c. Containment backflow prevention assemblies shall be installed immediately downstream of the water meter, prior to any service connections, in compliance with all applicable codes and regulations.
- d. Access for inspection, testing, repair, maintenance and/or replacement of backflow prevention assemblies that serve more than one (1) property, such as a master-metered facility, shall not be contingent on access of a private residence or business. Such installations shall be located in an area accessible from the exterior, such as a mechanical room or an ASSE 1060-certified enclosure that is protected against freezing and meeting all installation criteria identified herein.
- e. Before installing a backflow prevention assembly, pipelines shall be thoroughly flushed to remove foreign material.
- f. Thermal expansion equipment shall be installed on all water systems contained by a backflow prevention assembly.
- g. Backflow prevention assembly valves shall not be used as the inlet or outlet valve of the water meter. Test cocks shall not be used as supply connections.
- h. All costs for design, installation, maintenance, repair and testing shall be borne by the utility customer.

5.8 Testing and maintenance.

Backflow prevention assemblies shall be tested and maintained as described below:

- a. Backflow prevention assembly testing shall be conducted by a Certified Cross Connection Control Technician using the latest test procedures as specified by one of the following councils (A.S.S.E., A.B.C., A.B.P.A).
- b. All backflow prevention assemblies shall be tested by a certified technician at the time of installation, prior to issuance of a certificate of occupancy.
- c. Backflow prevention assemblies shall be tested immediately upon installation, repair, replacement or alteration of plumbing upstream of the assembly.
- d. The Town retains the right to test or otherwise check the installation and operation of any testable assembly at any time to assure proper operation at the property customer's expense.
- e. Should a backflow prevention assembly not be installed in conformance with Town standards, the test report shall reflect such information and be recorded as a failure.
- f. All backflow prevention assemblies not meeting requirements shall be repaired or replaced at the water customer's expense. Any such repair or replacement shall be made with an approved backflow prevention assembly within ten (10) days of discovery by the user, a certified technician or the Department and/or its designee, unless arrangements satisfactory to the Department and/or its designee are made. Should the hazard presented to the water system be determined to present a significant health risk, immediate service discontinuance may be necessary until such repair or replacement is accomplished.

5.9 Record keeping.

- a. The certified technician shall report on a form approved by the Town
- b. Records of all tests, inspections, repairs and replacements of backflow prevention assemblies shall be kept by the water customer, the certified technician and the Town for a period of three (3) years.
- c. The certified technician is required to send copies of all passed test reports to the owner and the Town within ten (10) business days after testing, inspecting or repairing any backflow prevention assembly. The certified technician should repair a failed assembly immediately, if possible. When an assembly failure is a potential threat to the potable water system or the environment and cannot be repaired immediately, the certified technician must report the failure verbally to the owner and the Town and/or its designee. The technician must send written notification to the owner and the Town and/or its designee within three (3) working days.
- d. Copies of records of test reports, repairs and retests shall be submitted to the Town by mail or e-mail by the testing company or testing technician. Information on test reports shall include, but may not be limited to:
 1. Test reports to be provided on company letter head
 2. Company information (name, address, phone number)
 3. Assembly or method type
 4. Assembly or method location address (For multiple businesses on a single protection device, list on the report each business name and address information for each protected)
 5. Assembly make, model and serial number
 6. Assembly size
 7. Test date and results including all results that would justify a pass or fail outcome.
 8. Certified cross-connection control technician certification agency
 9. Technician's name
 10. Technician's certification number
 11. Technician's certification expiration date
 12. Test kit manufacturer, model and serial number
 13. Test kit calibration date

5.10 Right of entry.

- a. The Town representative and/or his or her designee assigned to inspect premises relative to possible hazards shall carry proper credentials of his or her office and, upon exhibit of which, said representative shall have the right of entry to inspect any and all buildings and premises for cross-connections in the performance of his or her duties. If such entry is refused, the Town administrative authority or the designated authorized representative thereof shall have recourse to every remedy provided by law to secure entry.

- b. This right of entry shall be a condition of water service in order to provide assurance that the health, safety and welfare of the people throughout the Town's potable water distribution system are maintained. Where building security is required, the backflow assembly or assemblies should be located in an area not subject to security. Questions regarding proper credentials should be directed to the Town.

5.11 Compliance.

- a. Customers shall cooperate with the installation, inspection, testing, maintenance, and as needed repair and replacement of backflow prevention assemblies and with the Cross Connection Survey process. For any identified uncontrolled cross-connections, the Town will complete one of the following actions within sixty (60) days of its discovery:
 - 1. Control the cross connection
 - 2. Remove the cross connection
 - 3. Suspend service to the cross connection
- b. Service of water to any premises may be discontinued by the Town if unprotected cross-connections exist on the premises, if any defect is found in an installed backflow prevention assembly or if a backflow prevention assembly has been removed or bypassed. Service shall not be restored until such conditions or defects are corrected.
- c. Discontinuance of service may be summary, immediate and without written notice whenever, in the judgment of the Town Administrator or the designated representative thereof, upon the recommendation of the Town or a registered certified cross-connection control technician, such action is necessary to protect the purity of the public potable water supply or the safety of the water system.
- d. Suspended Disconnection. At the Town's discretion, severing the service connection will be performed if degree of hazard warrants such action in order to protect the Town's potable water supply. Discontinuance of service may be summary, immediate, and without written notice whenever, in the judgment of the Town, such action is necessary to protect the Town's potable water supply or the distribution system.
- e. The Town will give notice in writing to any owner whose plumbing system has been found to present a risk to the public waters system's distribution system through an uncontrolled cross connection. The notice and order shall state that the owner must install a backflow prevention assembly or method at each service connection to the owner's premises to contain the water service. The notice and order will give a date by which the owner must comply.

5.12 Requirements of the Consumer.

- (a) All “Non-Single Family Residential” consumers must complete and submit a Cross Connection Survey to the Town, unless, they have a reduced pressure zone (RPZ) Backflow Prevention Assembly that is tested annually.
- (b) Cross-Connection(s). The consumer shall be responsible for the elimination or protection of all cross-connections (known or unknown by the Town) on his/her premises by an approved backflow device at his/her expense. Such backflow device expenses shall include installation, maintenance, protection, testing, repair, removal or replacement of said device(s) as required by the Town as a condition of service.
- (c) Any consumer determined by the Town to be an “Unacceptable Health and/or Safety Risk” shall have an acceptable (for the level of risk) backflow assembly installed and tested annually. All test reports shall be submitted to the Town.
- (d) The consumer or those occupying any premise shall not bypass, disable, remove, or modify any backflow device without written consent by the Town. Any such modifications shall result in termination of service.
- (e) The consumer or those designated by him or her shall comply with current N.F.P.A. standards and/or the current Town Standards, as amended, when designing, installing and maintaining any fire suppression system as a condition of service. The Consumer and/or those whom are designated for the design and installation of the system will need to provide verification of approval by the Elizabeth Fire District.

5.13 Plan approval.

All building and/or construction plans involving water/sewer service, plumbing plans for additions or alterations to existing plumbing systems, and/or irrigation system installation submitted to the Town at owner’s expense, shall be reviewed by the Town and/or its designee and approved prior to issuance of a permit.

5.14 Fees.

The Board of Trustees may establish and adopt a schedule of fees to be paid by the developer/builder to defray the expenses of the Town in reviewing plans and/or inspecting work. Further, the Town may charge a reasonable fee for copies of any documents.

5.15 Violations and Penalties.

Any person, whether as principal, agent, employee or otherwise, who violates any of the provisions of Section 5 of these Standards shall be subject to the general penalties as set forth in Section 1-4-20 of the Town Code.

C:\USERS\AND56829\DESKTOP\ELIZABETH\REV - SEPT 2016 - RJA MM COMENTS) ELIZABETH WATER AND SEWER STANDARDS 9-19-16.DOCX

STANDARD DETAILS

STANDARD DETAILS - GENERAL

THESE DESIGNS, PLANS, AND CONTRACT DOCUMENTS ARE REVIEWED FOR CONCEPT AND GENERAL CONFORMANCE TO THE TOWNS' MINIMUM STANDARDS ONLY, AND THE PRIMARY RESPONSIBILITY FOR DESIGN ADEQUACY IS TO REMAIN WITH THE ENGINEER OF RECORD. THIS REVIEW DOES NOT IMPLY RESPONSIBILITY BY THE TOWN OF ELIZABETH, OR THE TOWN ENGINEER FOR COMPLETENESS, ACCURACY OR CORRECTNESS OF CALCULATION. THE REVIEW DOES NOT IMPLY THAT QUANTITIES OF ITEMS INDICATED ON THE PLANS ARE THE FINAL QUANTITIES REQUIRED. THE REVIEW SHALL NOT BE CONSTRUED FOR ANY REASON AS ACCEPTANCE OF FINANCIAL RESPONSIBILITY BY THE TOWN FOR ADDITIONAL ITEMS AND ADDITIONAL QUANTITIES OF ITEMS SHOWN THAT MAY BE REQUIRED DURING THE CONSTRUCTION PHASE.

APPROVED FOR CONSTRUCTION WITHIN ONE YEAR OF THE EARLIEST OF THESE DATES:

BY _____	_____
TOWN ENGINEER	DATE
BY _____	_____
TOWN OF ELIZABETH-PUBLIC WORKS DIRECTOR	DATE
BY _____	_____
TOWN OF ELIZABETH-TOWN ADMINISTRATION	DATE
BY _____	_____
ELIZABETH FIRE DEPARTMENT	DATE

 TOWN OF ELIZABETH	
STANDARD APPROVAL BLOCK	
SCALE: NTS	DATE: APRIL 2025
LAST REVISED: FEBRUARY 2017	G1
WATER AND SEWER STANDARDS	

IMAGES: P:\0 - MASTER DETAILS\OTHER FIRMS DETAILS\ELIZABETH STANDARD DETAILS - 2-9-17\DETAILS\G2-TYPICAL STREET SECTION.DWG

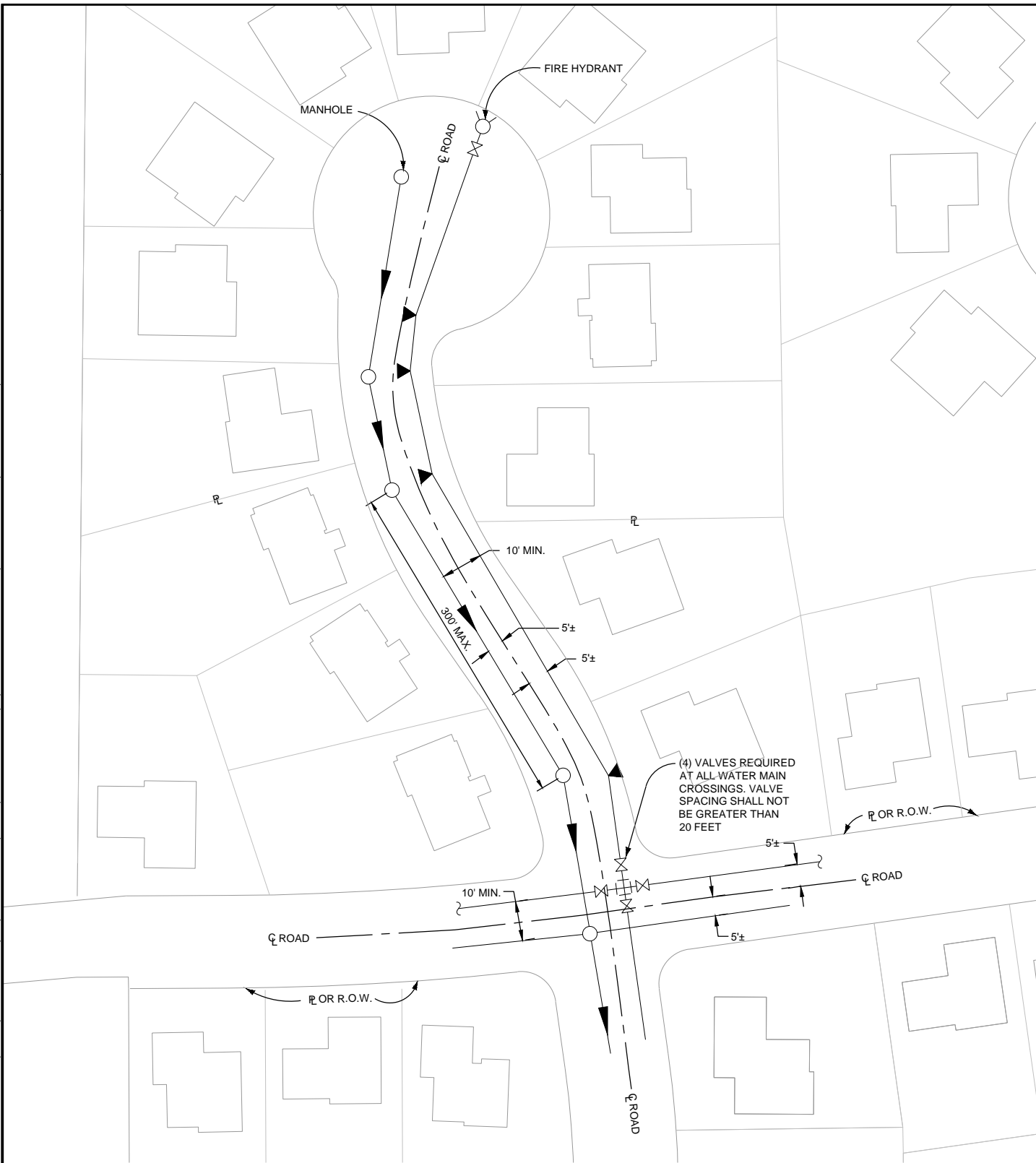

 TOWN OF ELIZABETH	
TYPICAL WATER AND SEWER STREET PLAN	
SCALE: NTS	DATE: APRIL 2025
LAST REVISED: FEBRUARY 2017	
WATER AND SEWER STANDARDS	
G2	



29/17 14:33 ARC6682 R19 P10 - MASTER DETAILS/OTHER FIRMS DETAILS/ELIZABETH STANDARD DETAILS/ELIZABETH.JPG

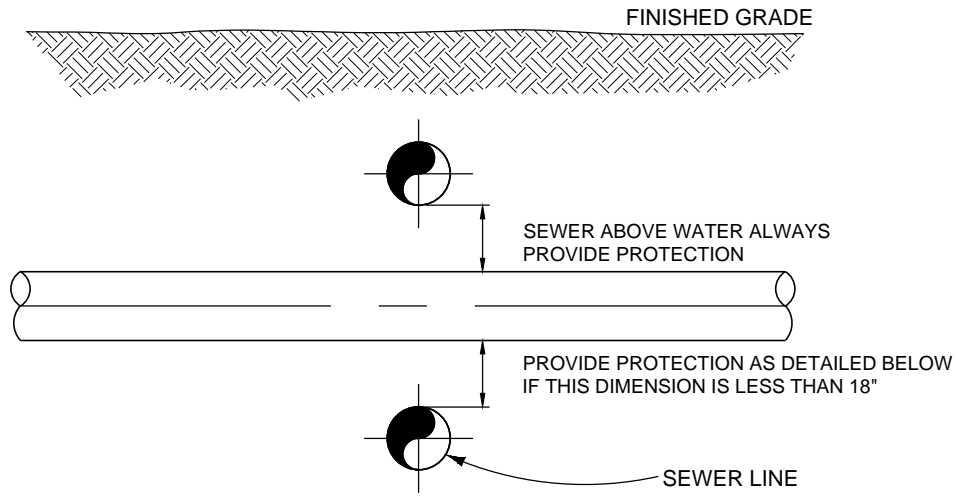

SECTION

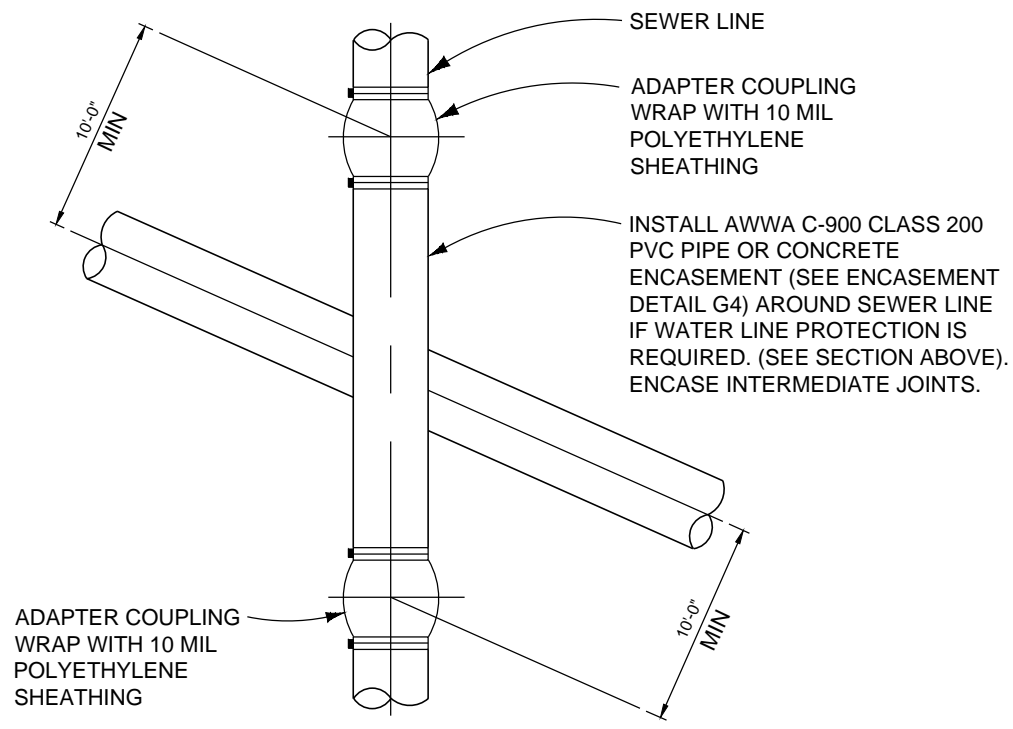

PLAN

 TOWN OF ELIZABETH	
SEWER AND WATER LINE CROSSING	
SCALE: NTS	DATE: APRIL 2025
LAST REVISED: FEBRUARY 2017	
G3	
WATER AND SEWER STANDARDS	

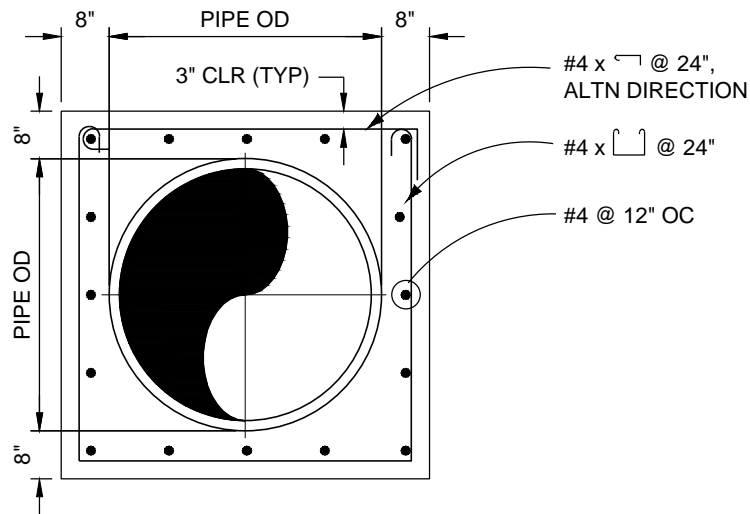

NOTES:

1. FOR TIE-INS TO STRUCTURES EXTEND LONGITUDINAL REINFORCING INTO WALL OR SLAB, PROVIDE DOWELS AT EACH END.
2. PROVIDE TWO FLEXIBLE JOINTS WITHIN SIX FEET OF EACH END OF ENCASEMENT.
3. USE GR 40 REINF. BARS.
4. CONCRETE SHALL HAVE A MINIMUM COMPRESSION STRENGTH OF 3,000 psi AT 28 DAYS

 TOWN OF ELIZABETH			
CONCRETE ENCASEMENT			
SCALE: NTS	DATE: APRIL 2025		
LAST REVISED: FEBRUARY 2017			
<table border="1" style="width: 100%;"> <tr> <td style="width: 80%;">WATER AND SEWER STANDARDS</td> <td style="width: 20%; text-align: center; font-size: 2em;">G4</td> </tr> </table>		WATER AND SEWER STANDARDS	G4
WATER AND SEWER STANDARDS	G4		

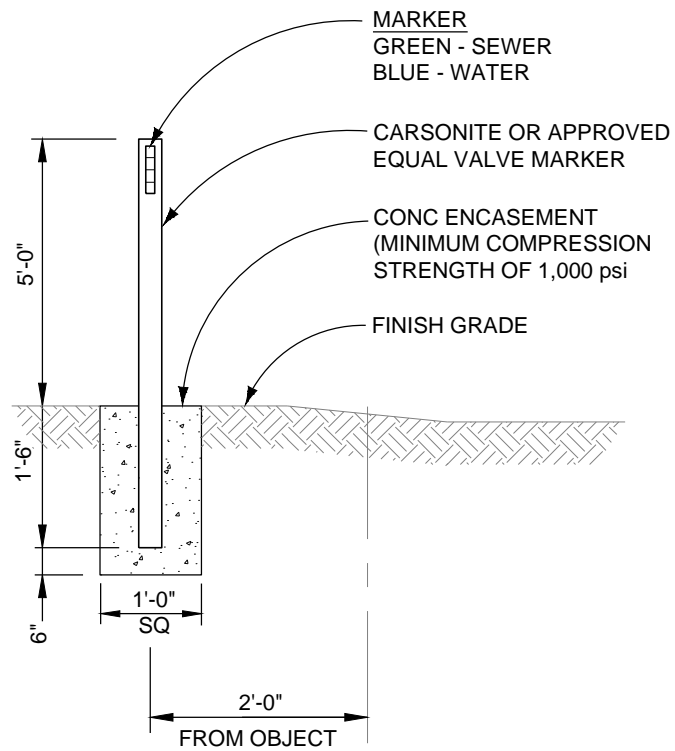

 TOWN OF ELIZABETH	
SURFACE MARKER	
SCALE: NTS	DATE: APRIL 2025
LAST REVISED: FEBRUARY 2017	
WATER AND SEWER STANDARDS	
G5	

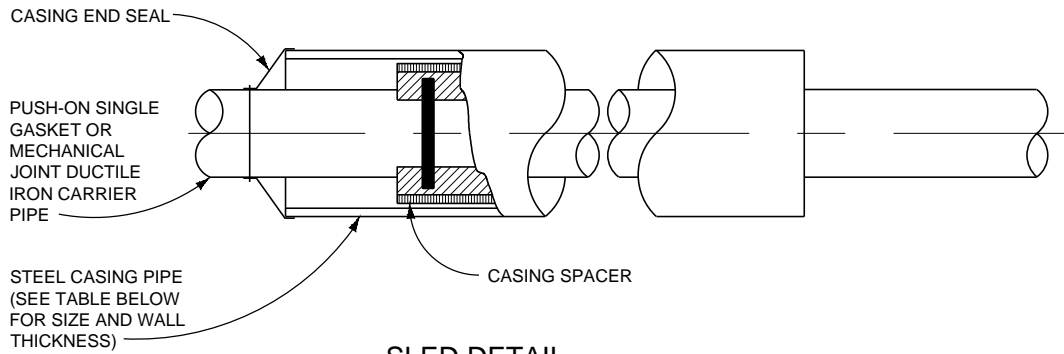

SLED DETAIL

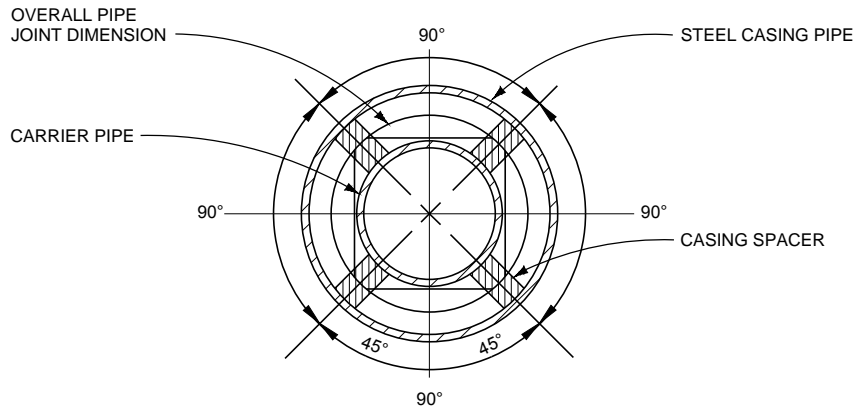

PIPE CASING DETAIL

CARRIER PIPE NOMINAL DIA.	CASING PIPE	
	MIN. O.D.	MIN. WALL THICK
4"	12"	0.188"
6"	16"	0.250"
8"	18"	0.282"
12"	22"	0.344"
16"	28"	0.406"
20"	32"	0.469"

NOTES:

1. NEOPRENE OR PVC RUNNERS MAY BE USED FOR CASING SPACERS.
2. TRENCH LAID CASINGS SHALL BE DESIGNED AND INSTALLED TO CONDUIT STANDARDS.
3. USE HARNESS LUGS FOR WATER MAIN RESTRAINT (SEE DWG G7).

TOWN OF ELIZABETH	
BORE CASING	
SCALE: NTS	DATE: APRIL 2025
LAST REVISED: FEBRUARY 2017	
WATER AND SEWER STANDARDS	
G6	

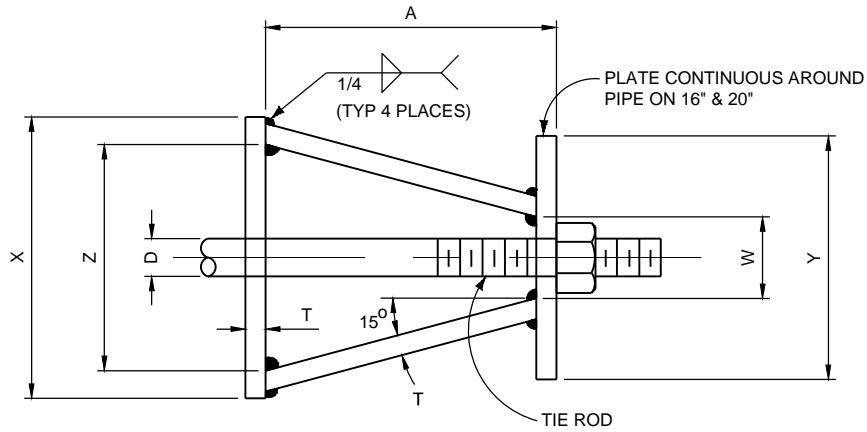

TOP VIEW

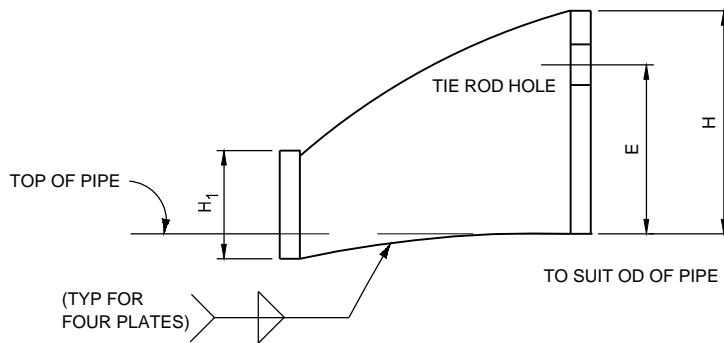

SIDE VIEW

	CARRIER PIPE NOMINAL DIA.	STUD DIA. D	A	W	Z	T	H	E	H ₁	Y	X
W/O FLANGED LUGS	4" TO 12"	3/4"	5"	1-1/2"	3-3/4"	3/8"	4-1/8"	3-1/8"	2"	4-1/2"	5"
	16"	1"	5-3/4"	1-3/4"	4-1/2"	1/2"	4-1/2"	3-1/4"	2"	RING	6"
	20"	1-1/4"	7-1/2"	2"	5-3/4"	5/8"	5"	3-3/4"	2-1/2"	RING	7-1/2"

NOTES:

1. USE TWO HIGH STRENGTH STAINLESS STEEL TIE RODS AT END OF CASING.
2. TIE ROD HOLE DIAMETER 1/8" LARGER THAN STUD DIAMETER.
3. BOTTOM EDGE OF ALL PLATES SHAPED TO FIT OD OF PIPE.
4. HARNES LUGS AS PER AWWA MANUAL M-II.
5. WARP W/ 10 MIL POLYETHYLENE SHEATHING.

TOWN OF ELIZABETH	
HARNES LUGS - BORE CASING	
SCALE: NTS	DATE: APRIL 2025
LAST REVISED: FEBRUARY 2017	
G7	
WATER AND SEWER STANDARDS	

STANDARD DETAILS – SEWER SYSTEM

2/9/17 15:27 ARC56862 R19 P:\0 - MASTER DETAILS\OTHER FIRMS DETAILS\ELIZABETH STANDARD DETAILS\ELIZABETH.JPG; 2/9/17 15:27 ARC56862 R19 P:\0 - MASTER DETAILS\OTHER FIRMS DETAILS\ELIZABETH STANDARD DETAILS\ELIZABETH.JPG;

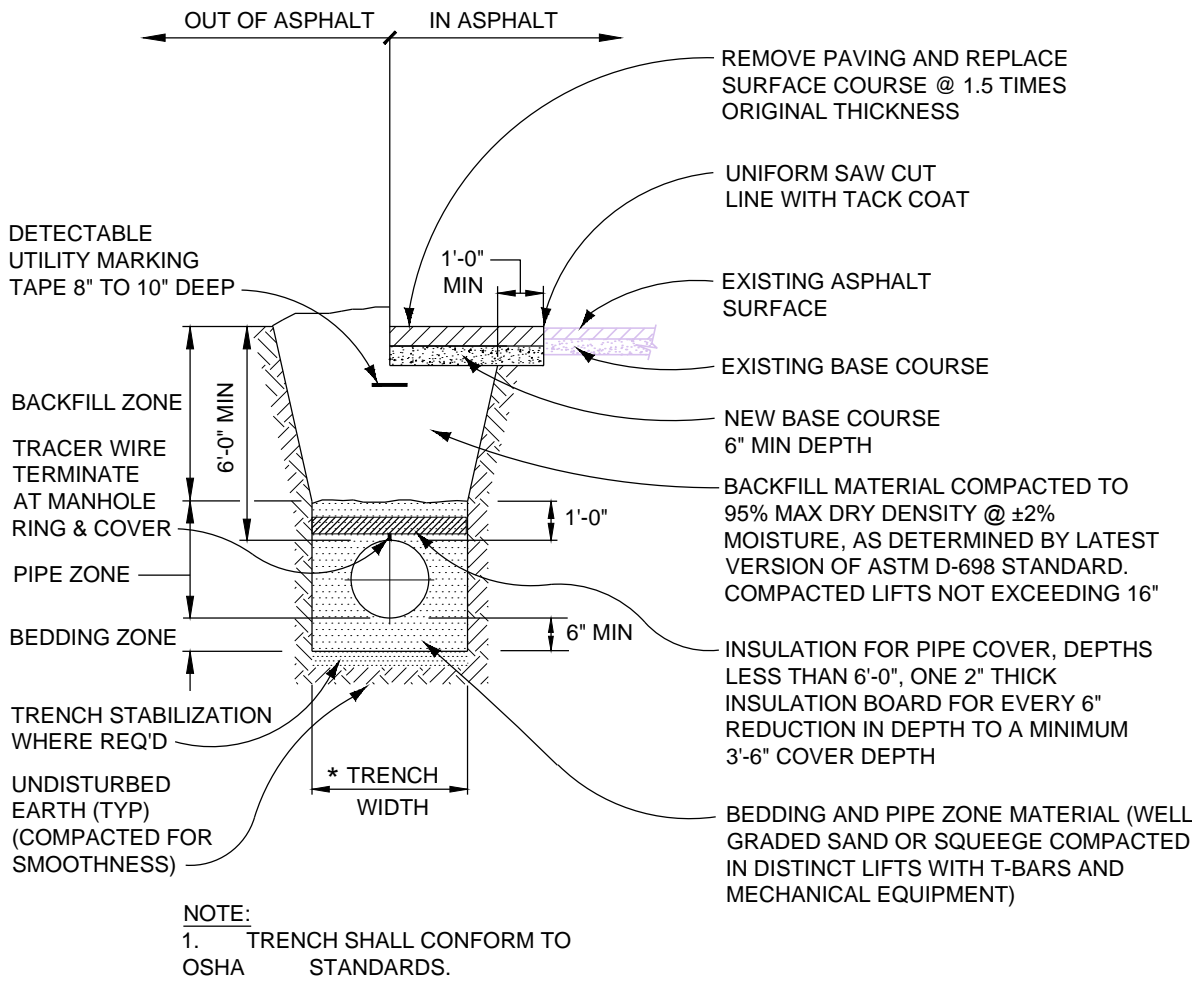

* MAXIMUM TRENCH WIDTH = 24" + NORMAL PIPE DIAMETER

 TOWN OF ELIZABETH	
SEWER PIPE TRENCH	
SCALE: NTS	DATE: APRIL 2025
LAST REVISED: FEBRUARY 2017	S1
WATER AND SEWER STANDARDS	

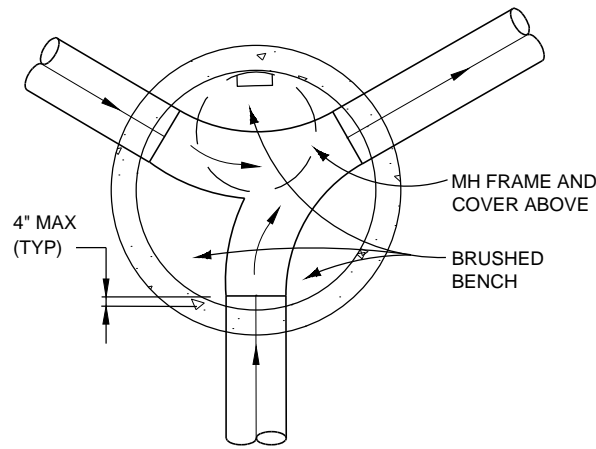

TYPICAL PLAN

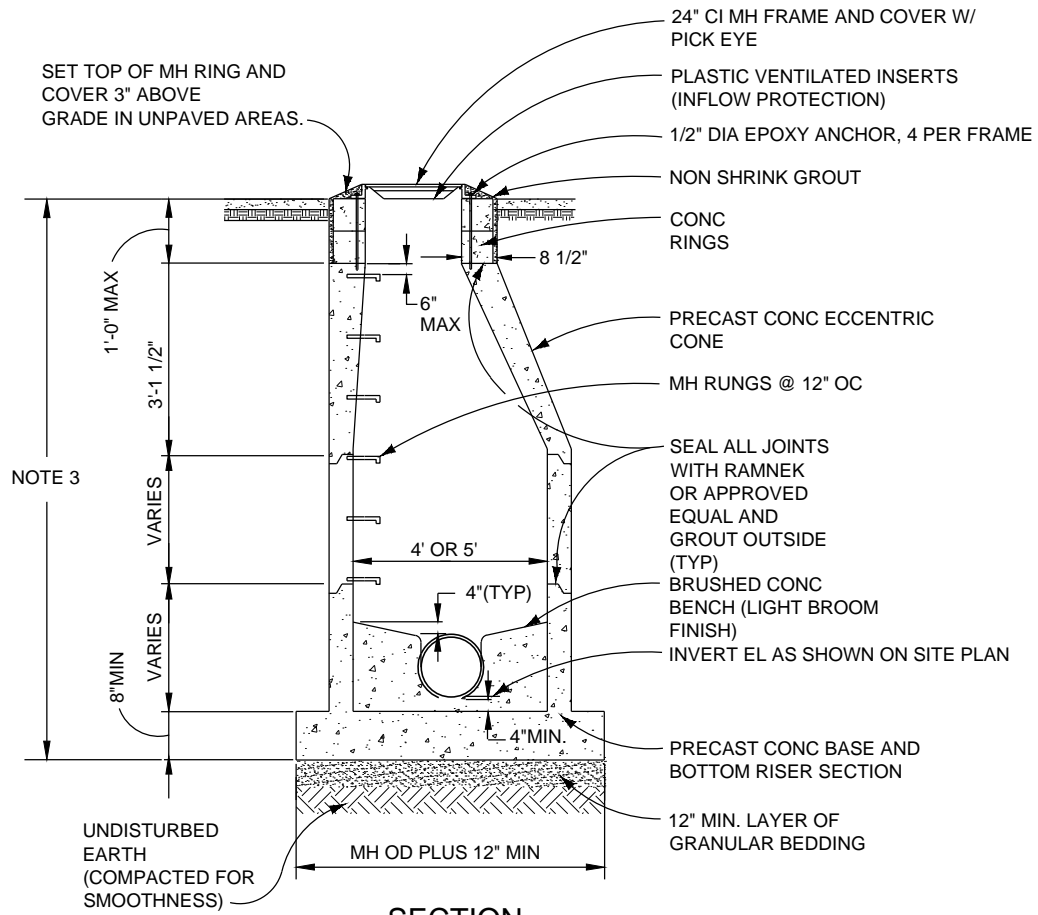

SECTION

NOTES:

1. ALL COMPONENTS SHALL BE CAPABLE OF HS-20 LOADING.
2. INSTALL ALL PIPES INTO MANHOLES WITH FLEXIBLE PIPE-TO-MANHOLE CONNECTORS.
3. USE PRECAST FLAT TOP COVER FOR SEWER DEPTHS LESS THAN 6'-0" (SEE DWG. S4).

TOWN OF ELIZABETH	
STANDARD MANHOLE	
SCALE: NTS	DATE: APRIL 2025
LAST REVISED: FEBRUARY 2017	
WATER AND SEWER STANDARDS	
S2	

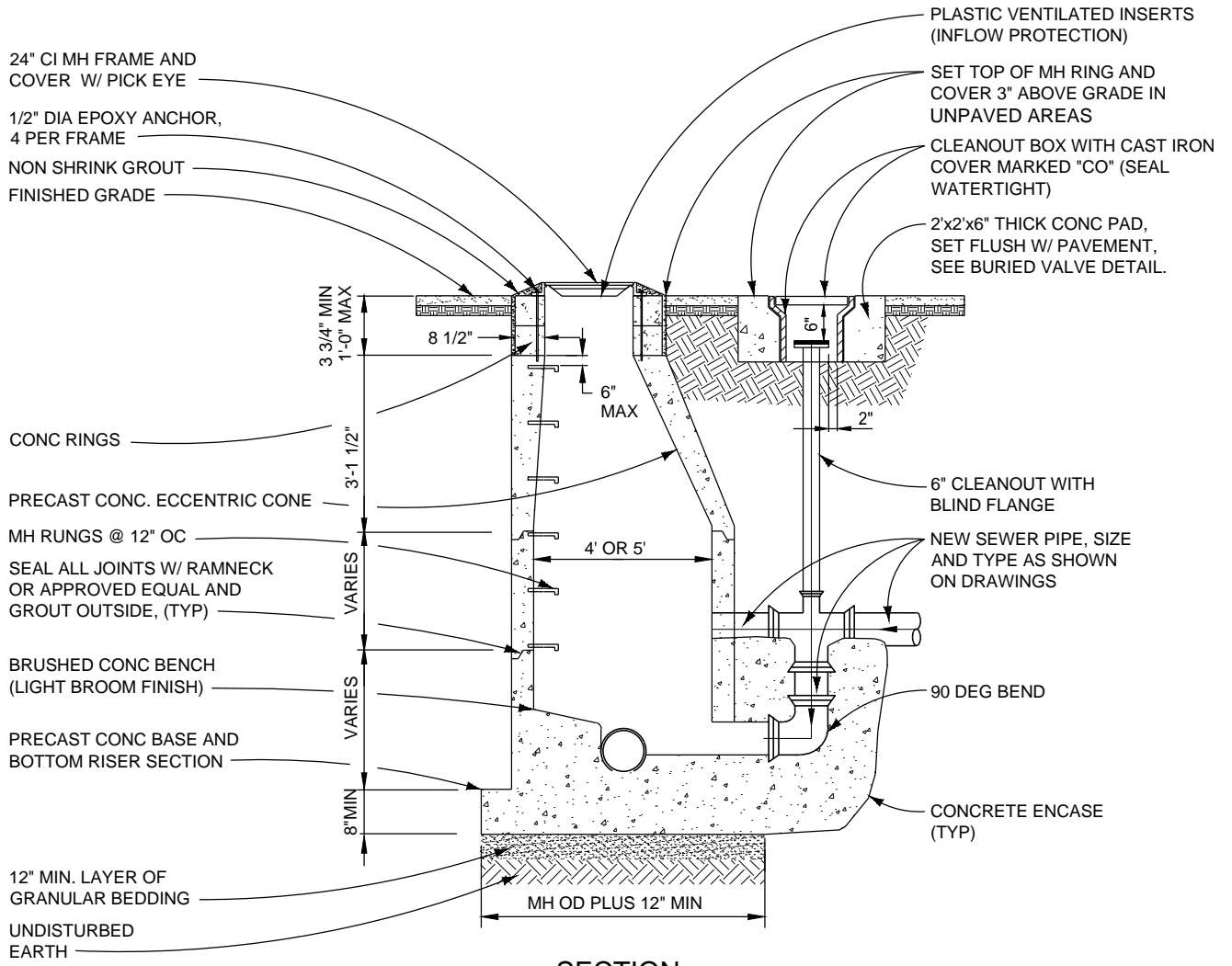

SECTION

- NOTES:**
1. ALL COMPONENTS SHALL BE CAPABLE OF HS-20 LOADING.
 2. INSTALL ALL PIPES INTO MANHOLES WITH FLEXIBLE PIPE-TO-MANHOLE CONNECTORS.
 3. DROP MH SHALL BE USED FOR ALL SITUATIONS WHERE INVERT OF PIPES ENTER MH AT 24" OR HIGHER ABOVE THE INVERT OUT ELEVATION.
 4. MIN OF 18" CONC REQUIRED BENEATH 90° BEND.

TOWN OF ELIZABETH	
DROP MANHOLE	
SCALE: NTS	DATE: APRIL 2025
S3	
WATER AND SEWER STANDARDS	

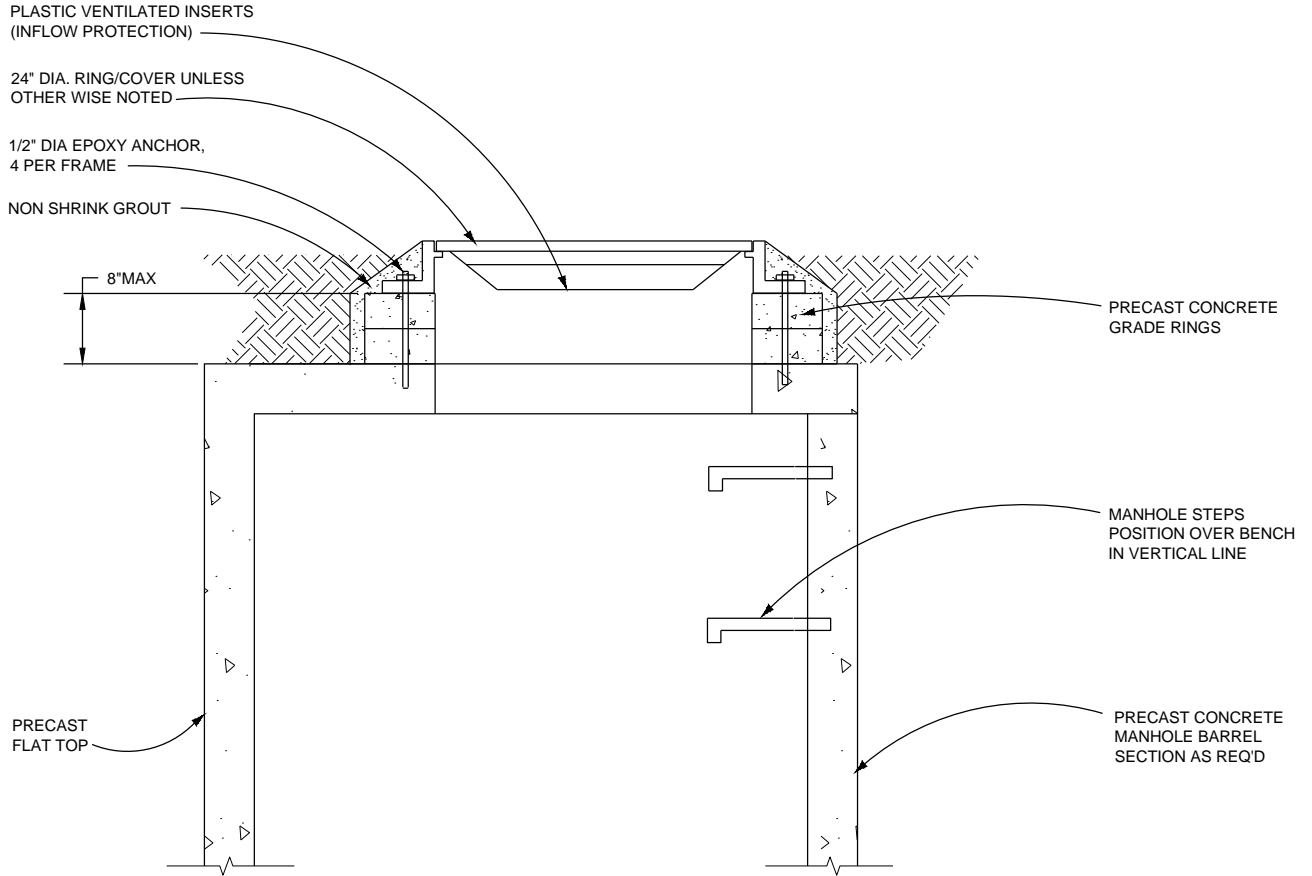

- NOTES:
1. PRECAST SECTIONS TO CONFORM TO ASTM-C-478.
 2. RING/COVER AND GRADE RINGS TO BE SET ON FULL BED OF MORTAR.

 TOWN OF ELIZABETH	
FLAT TOP MANHOLES	
SCALE: NTS	DATE: APRIL 2025
LAST REVISED: FEBRUARY 2017	
S4	
WATER AND SEWER STANDARDS	

2/13/17 18:03 ARC56862 R19 P:\0 - MASTER DETAILS\OTHER FIRMS DETAILS\ELIZABETH STANDARD DETAILS\DETAILS\ELIZABETH.JPG; P:\0 - MASTER DETAILS\OTHER FIRMS DETAILS\ELIZABETH STANDARD DETAILS\DETAILS\ELIZABETH.JPG;

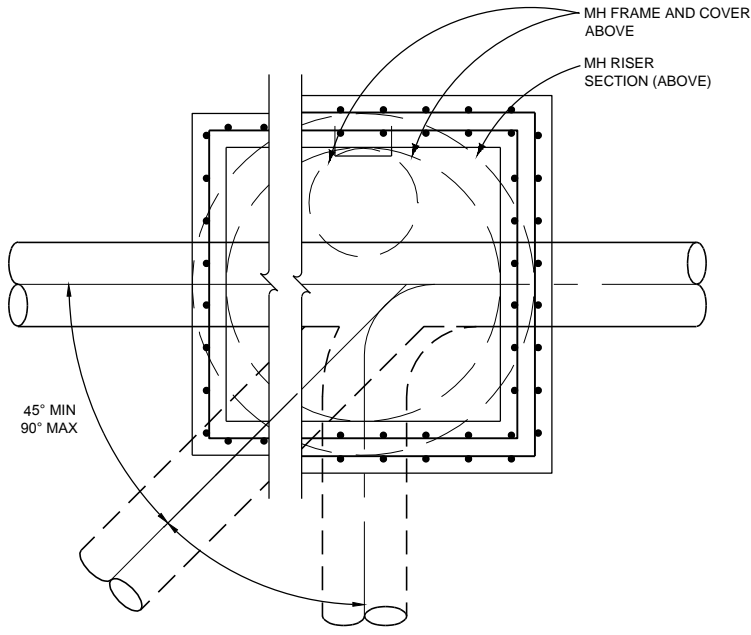

PLAN

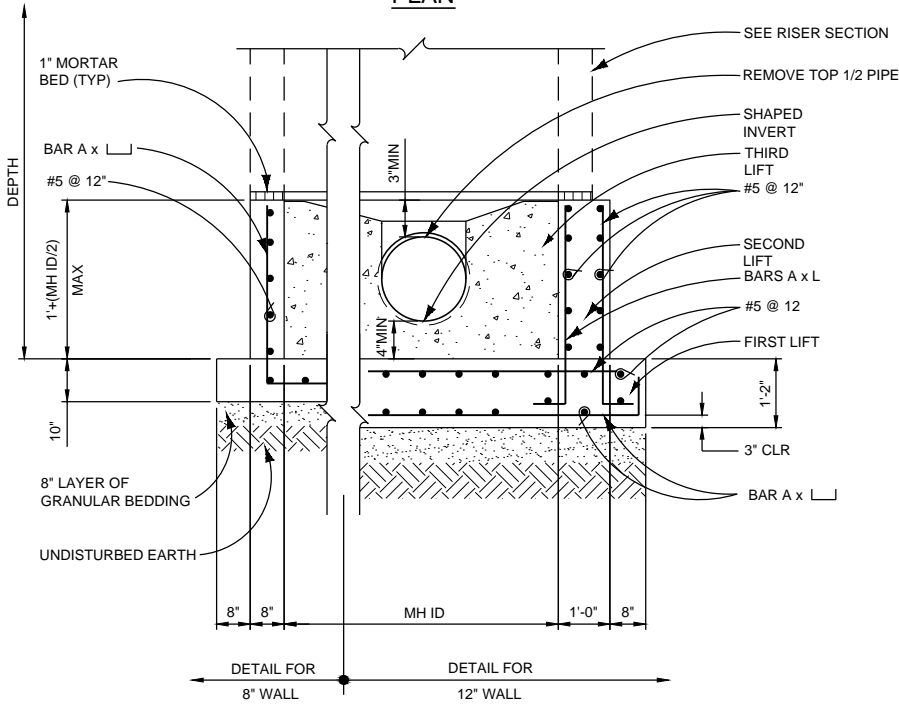

SECTION

REFER TO TABLE 1

MANHOLE RISER SECTION DIA	DEPTH BELOW FINISHED GRADE	REQD WALL	BARSA
4' ID	0 TO 8'	8"	#5 @ 12"
	8' TO 10'	8"	#5 @ 6"
	10' TO 20'	12"	#6 @ 12"
5' ID	0 TO 6'	8"	#5 @ 12"
	6' TO 10'	8"	#5 @ 6"
	10' TO 15'	12"	#6 @ 12"
6' ID	15' TO 20'	12"	#6 @ 6"
	0 TO 6'	8"	#5 @ 12"
	6' TO 9'	8"	#5 @ 6"
7' ID	9' TO 14'	12"	#6 @ 12"
	14' TO 20'	12"	#6 @ 6"
	0 TO 6'	8"	#5 @ 12"
7' ID	6' TO 9'	8"	#5 @ 6"
	9' TO 12'	12"	#6 @ 12"
	12' TO 20'	12"	#6 @ 6"

* MINIMUM CONCRETE COVER OVER BARS SHALL BE 2" UNLESS NOTED OTHERWISE

TOWN OF ELIZABETH

**CAST-IN-PLACE
MANHOLE BASE**

SCALE: NTS
DATE: APRIL 2025

LAST REVISED: FEBRUARY 2017

S5

WATER AND SEWER STANDARDS

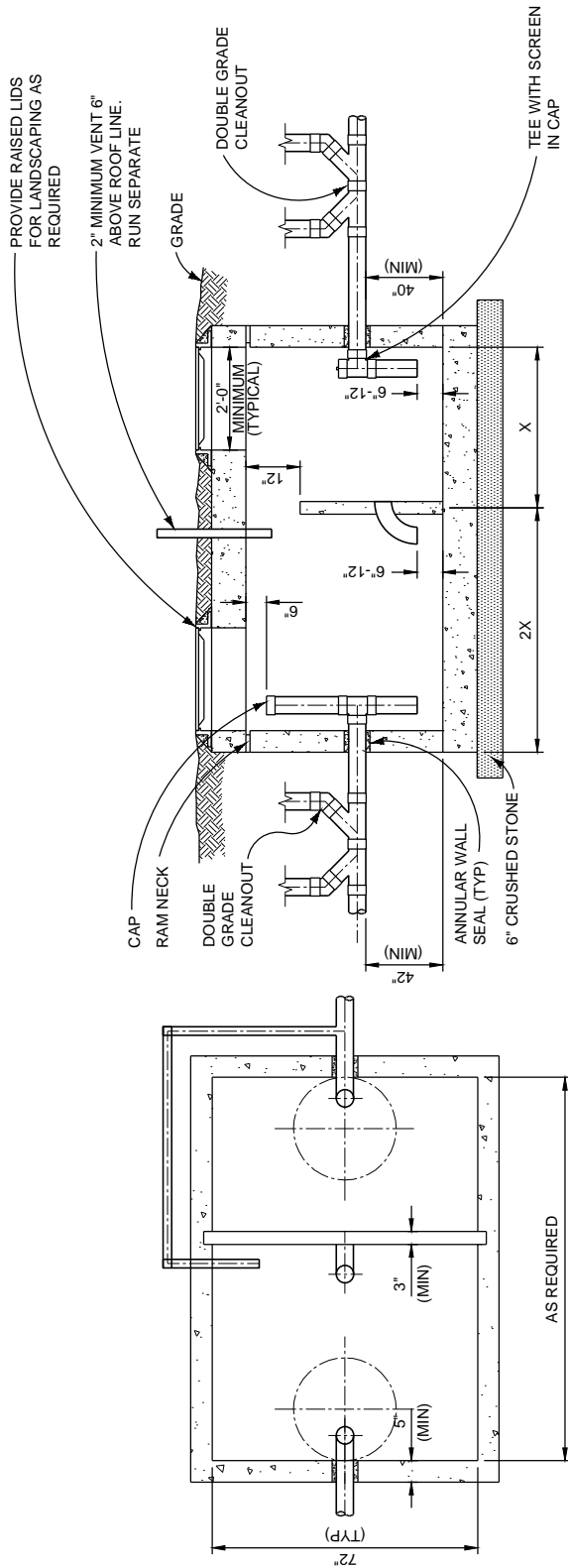

PLAN

SECTION

NOTES:

1. SIZE GREASE INTERCEPTOR PER TOWN WATER AND SEWER STANDARDS.
2. EXTERIOR PIPE AND FITTINGS SHALL BE SDR-35 PVC, 4" DIAMETER MINIMUM.
3. MANHOLE RING AND COVER SHALL BE HS-20 TRAFFIC RATED.
4. FIBERGLASS TANKS ARE ACCEPTABLE AS ALTERNATE TO CONCRETE. FLOATATION CALCULATIONS WILL BE REQUIRED.
5. BACKFILL IN ACCORDANCE WITH MANUFACTURER'S RECOMMENDATIONS.
6. FINAL STRUCTURAL/REINFORCING AND RESISTANCE TO FLOATATION DESIGN OF PRECAST STRUCTURE TO BE COMPLETED BY MANUFACTURER OR PROFESSIONAL ENGINEER LICENSED IN THE STATE OF COLORADO.
7. INTERIOR PIPING SHALL BE GLUED SCHEDULE 40 PVC, 4" DIAMETER MINIMUM.
8. MINIMUM INTERCEPTOR SIZE SHALL BE 750 GALLONS.

EXTERIOR GREASE INTERCEPTOR

NTS

TOWN OF ELIZABETH	
EXTERIOR GREASE INTERCEPTOR	
SCALE: NTS	DATE: APRIL 2025
LAST REVISED: FEBRUARY 2017	
S6	
WATER AND SEWER STANDARDS	

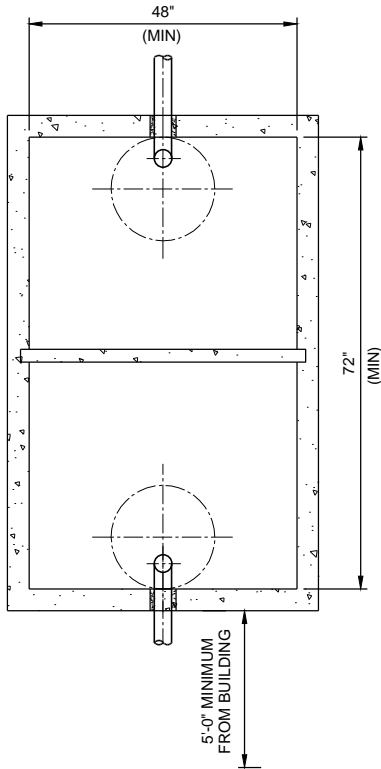

24\"/>

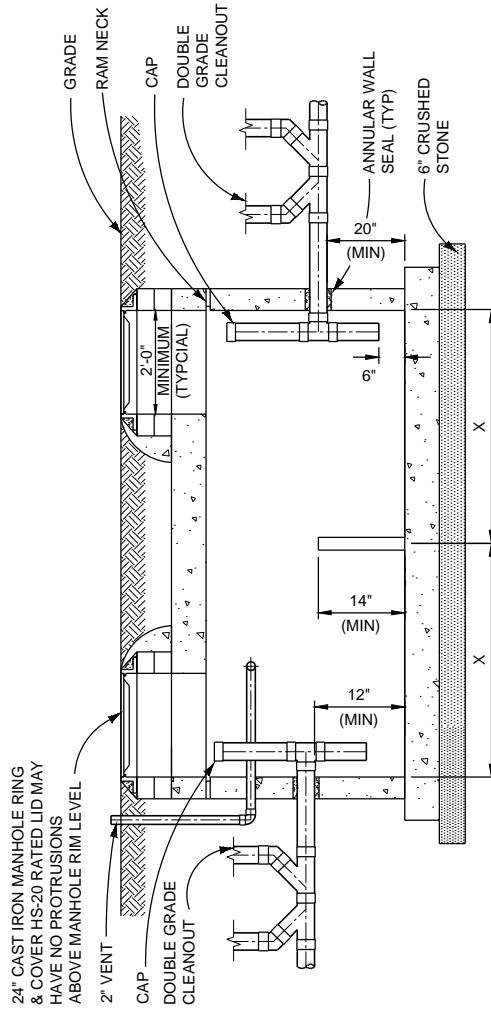

NOTES:

1. TOP OF VAULT BELOW FINISHED GRADE OR AT GRADE. IF BELOW GRADE, RING AND COVER SHALL BE ADJUSTED TO FINAL GRADE USING A MINIMUM OF 4\"/>
- 2. TOP OF VAULT BELOW FINISHED GRADE OR AT GRADE. IF BELOW GRADE, RING AND COVER SHALL BE ADJUSTED TO FINAL GRADE USING A MINIMUM OF 4\"/>
- 3. BACKFILL IN ACCORDANCE WITH MANUFACTURER'S RECOMMENDATIONS; NO BACKFILL MATERIAL SHALL BE 3\"/>
- 4. FINAL STRUCTURAL/REINFORCING AND RESISTANCE TO FLOATATION DESIGN OF PRECAST STRUCTURE TO BE COMPLETED BY MANUFACTURER OR PROFESSIONAL ENGINEER LICENSED IN THE STATE OF COLORADO.
- 5. INTERIOR PIPING SHALL BE GLUED SCHEDULE 40 PVC, 4\"/>
- 6. EXTERIOR PIPING SHALL BE SDR-35, 4\"/>
- 7. MINIMUM INTERCEPTOR SIZE SHALL BE 500 GALLONS.

SAND AND OIL INTERCEPTOR
NTS

TOWN OF ELIZABETH	
SAND AND OIL INTERCEPTOR	
SCALE: NTS	DATE: APRIL 2025
LAST REVISED: FEBRUARY 2017	
S7	
WATER AND SEWER STANDARDS	

STANDARD DETAILS – WATER SYSTEM

2/13/17 16:44 ARC56862 R19 P: 0 - MASTER DETAILS\OTHER FIRMS DETAILS\ELIZABETH STANDARD DETAILS\ELIZABETH.JPG; 2-9-17\DETAILS\WI-PIPE TRENCH.DWG IMAGES: P: 0 - MASTER DETAILS\OTHER FIRMS DETAILS\ELIZABETH STANDARD DETAILS\ELIZABETH.JPG;

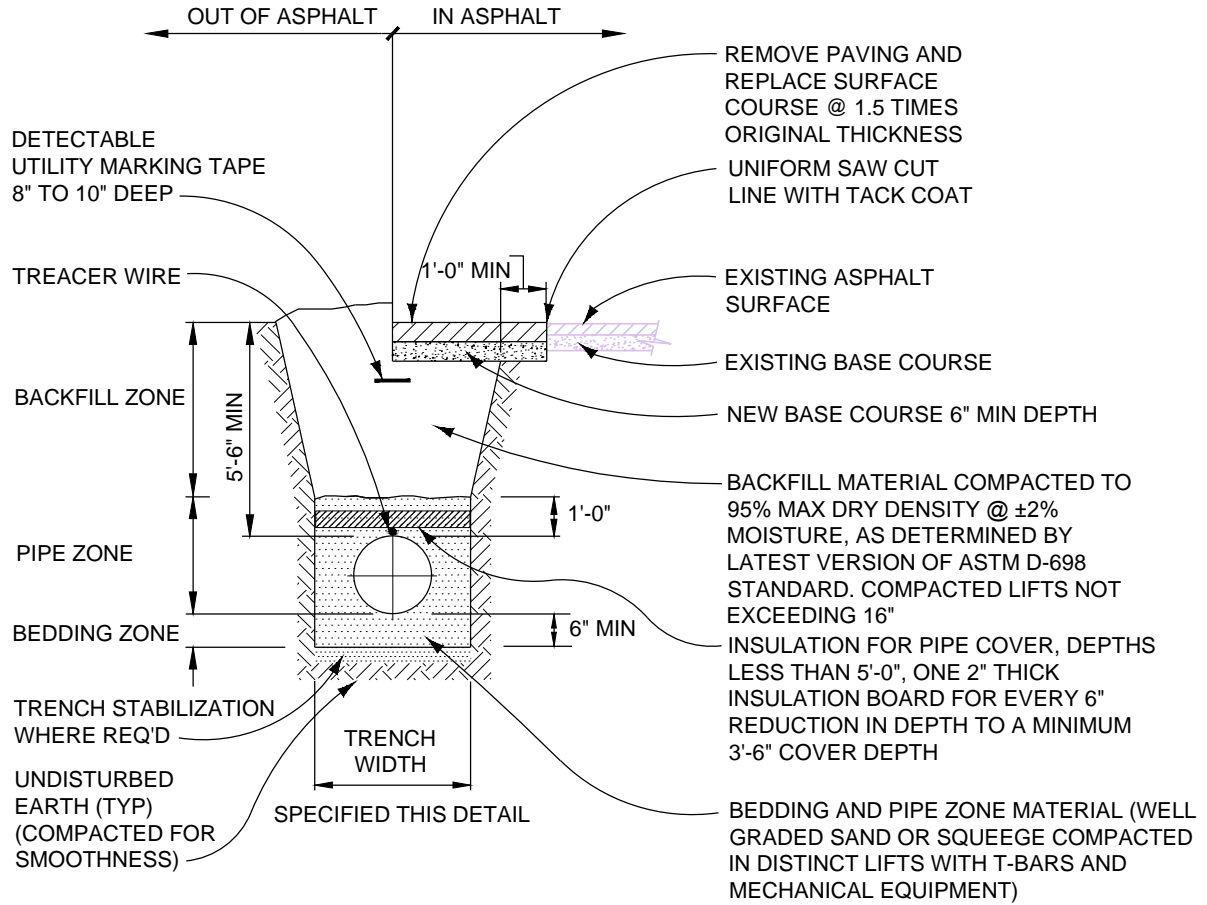

NOTE:
 1. TRENCH SHALL CONFORM TO OSHA STANDARDS.

TRENCH WIDTH SHALL CONFORM TO THE FOLLOWING:

PIPE I.D.	MIN. WIDTH	MAX. WIDTH
4" OR SMALLER	1'-4"	2'-4"
6"	1'-6"	2'-6"
8"	1'-8"	2'-8"
12"	2'-0"	3'-0"
16"	2'-4"	3'-4"

 TOWN OF ELIZABETH	
WATER PIPE TRENCH	
SCALE: NTS	DATE: APRIL 2025
LAST REVISED: FEBRUARY 2017	
W1	
WATER AND SEWER STANDARDS	

GENERAL:

1. ALL BURIED PIPING FITTINGS SHALL BE PROVIDED WITH CONCRETE THRUST BLOCKS AT ALL DIRECTION CHANGES UNLESS OTHERWISE NOTED.
2. IN ADDITION TO THRUST BLOCKS, ALL FITTINGS AND VALVES SHALL BE RESTRAINED FOR AT LEAST 40 FEET IN ALL DIRECTIONS. MEGALUGS MAY BE USED ON DIP AND PVC PIPE FOR RESTRAINT EXCEPT IN LOCATIONS WHERE FLEXIBLE JOINTS ARE REQUIRED.
3. CONCRETE THRUST BLOCKING TO BE POURED AGAINST UNDISTURBED EARTH OR STRUCTURAL BACKFILL.
4. KEEP CONCRETE CLEAR OF JOINT, BOLTS, NUTS, CLAMPS, AND OTHER ACCESSORIES.
5. THRUST BLOCKS SHALL NOT BE LOCATED OR SIZED TO ENCASE ADJACENT PIPES OR FITTINGS.
6. A BOND BREAKER SHALL BE PLACED BETWEEN THE PIPE AND THRUST BLOCK.
7. DO NOT COVER ANY BOLT CONNECTIONS.

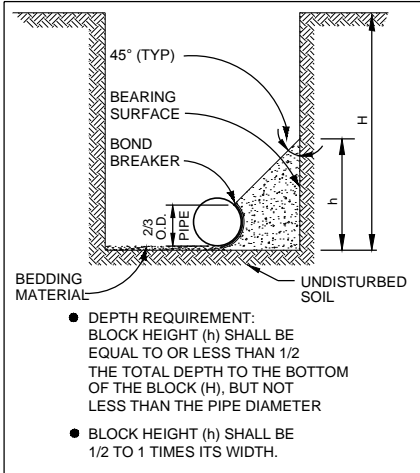

TYPICAL CROSS SECTION

FITTING SIZE (IN)	A ₁	A ₂			
	TEE, WYE PLUG OR CAP (SF)	90° BEND (SF)	45° BEND (SF)	22 1/2° BEND (SF)	11 1/4° BEND (SF)
4	1.4	2.0	1.1	1.0	1.0
6	3.2	4.5	2.4	1.2	1.0
8	5.7	8.0	4.3	2.2	1.1
10	8.8	12.5	6.8	3.4	1.7
12	12.7	18.0	9.7	5.0	2.5
14	17.3	24.5	13.3	6.8	3.4
16	22.6	32.0	17.3	8.8	4.4
18	28.6	40.5	21.9	11.2	5.6
20	35.3	50.0	27.1	13.8	6.9
24	50.9	72.0	39.0	19.9	10.0

TABLE 1 - BEARING AREA OF THRUST BLOCKS IN SQUARE FEET (HORIZONTAL BENDS & VERTICAL UPWARD BENDS)

HORIZONTAL BENDS AND VERTICAL UPWARD BENDS:

1. BEARING AREAS (TABLE 1) BASED ON TEST PRESSURE OF 150 psi, AN ALLOWABLE SOIL BEARING PRESSURE OF 2,000 psf AND A SAFETY FACTOR OF 1.5. TO COMPUTE BEARING AREAS FOR DIFFERENT TEST PRESSURES AND SOIL BEARING PRESSURES, USE THE FOLLOWING EQUATION:

BEARING AREA = (TEST PRESSURE / 150 psi) x (2,000 / SOIL BEARING PRESSURE psf) x (TABLE 1 VALUE)

2. UNLESS OTHERWISE NOTED ON THE GENERAL DRAWINGS IN THE GENERAL NOTES OR SPECIFICATIONS, USE SOIL BEARING PRESSURE = 2000 psf FOR THIS PROJECT.
3. BEARING AREA OF THRUST BLOCK SHALL NOT BE LESS THAN 1.0 SQUARE FOOT.
4. IF THE DEPTH REQUIREMENT (SEE TYPICAL CROSS SECTION) CAN NOT BE ACHIEVED, THE ENGINEER SHALL BE NOTIFIED.

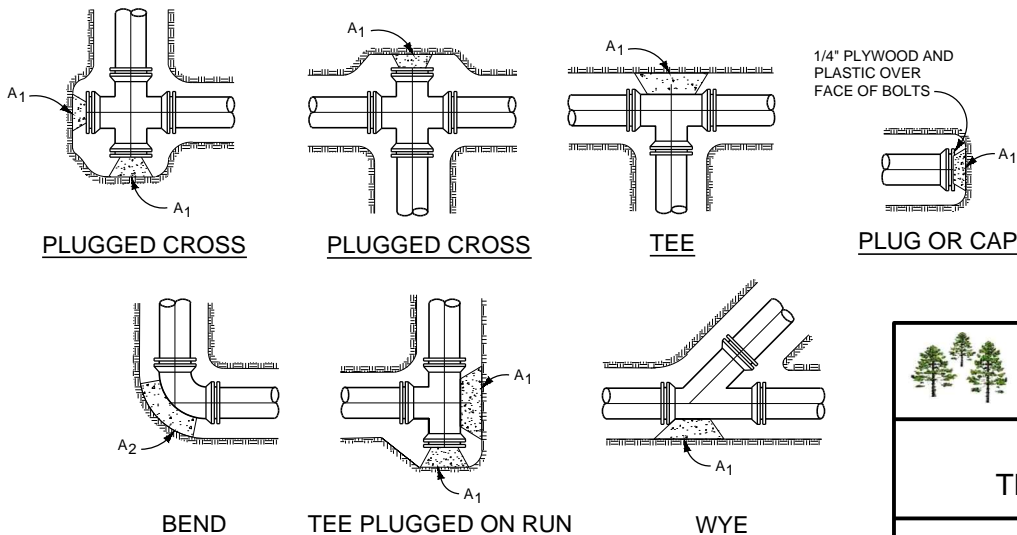

TOWN OF ELIZABETH	
HORIZONTAL THRUST BLOCKS	
SCALE: NTS	DATE: APRIL 2025
LAST REVISED: FEBRUARY 2017	W2
WATER AND SEWER STANDARDS	

**TABLE 2 - VOLUME OF THRUST BLOCK IN CUBIC YARDS
(VERTICAL DOWNWARD BENDS)**

FITTING SIZE (IN)	V ₁			ROD SIZE	EMBEDMENT (FT)
	45° BEND (CY)	22 1/2° BEND (CY)	11 1/4° BEND (CY)		
4	0.5	0.3	0.1	#6	2.5
6	1.1	0.6	0.3	#6	2.5
8	2.0	1.1	0.5	#6	2.5
10	3.1	1.7	0.9	#6	2.5
12	4.4	2.4	1.2	#6	2.5
14	6.1	3.3	1.7	#8	3.0
16	7.9	4.3	2.2	#8	3.0
18	10.0	5.4	2.8	#8	3.0
20	12.3	6.7	3.4	#8	3.0
24	17.8	9.6	4.9	#8	3.0

VERTICAL DOWNWARD BENDS:

1. VERTICAL BENDS THAT REQUIRE A THRUST BLOCK VOLUME EXCEEDING 5 CUBIC YARDS REQUIRE SPECIAL BLOCKING DETAILS. SEE DRAWINGS FOR VOLUMES SHOWN TO LEFT OF HEAVY, BOLD LINE IN TABLE 2.
2. THRUST BLOCK VOLUMES (TABLE 2) FOR VERTICAL DOWNWARD BENDS HAVING UPWARD RESULTANT THRUSTS ARE BASED ON TEST PRESSURE OF 150 PSI, THE WEIGHT OF CONCRETE = 4050 LBS/CUBIC YARD, AND A SAFETY FACTOR OF 1.5. TO COMPUTE VOLUMES FOR DIFFERENT TEST PRESSURES AND CONCRETE WEIGHTS, USE THE FOLLOWING EQUATION:

$$\text{VOLUME} = (\text{TEST PRESSURE} / 150) \times (4,050 / \text{CONCRETE WEIGHT}) \times (\text{TABLE 2 VALUE})$$

3. VOLUME OF THRUST BLOCK IN CUBIC YARDS FOR VALVES SHALL BE THE SAME VOLUME USED FOR 11 1/4° BENDS.

GALVANIZED OR EPOXY COATED RODS OVER FITTING AND EMBEDDED IN CONCRETE (SEE TABLE 2 FOR SIZES)

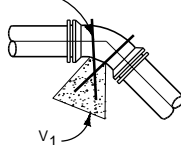

VERTICAL DOWNWARD BEND

GALVANIZED OR EPOXY COATED RODS OVER FITTING AND EMBEDDED IN CONCRETE (SEE NOTE 3)

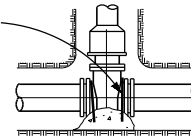

VALVE

THRUST RESTRAINTS

NTS

 TOWN OF ELIZABETH	
VERTICAL THRUST BLOCKS	
SCALE: NTS	DATE: APRIL 2025
LAST REVISED: FEBRUARY 2017	
W3	
WATER AND SEWER STANDARDS	

LENGTH OF RESTRAINED PIPE

PIPE SIZE	FITTING	90° BEND, TEE, PLUG, OR VALVE	45° BEND	22 1/2° BEND	11 1/4° BEND
4"	L	30'	9'	1'	-
6"	L	45'	13'	4'	-
8"	L	60'	18'	5'	1'
12"	L	90'	25'	7'	2'
14"	L	100'	28'	7'	2'
16"	L	110'	32'	8'	2'
20"	L	130'	39'	10'	3'
24"	L	160'	45'	12'	3'

NOTES:

1. LENGTH OF RESTRAINED PIPE MEASURED EACH WAY FROM VALVES AND BENDS.
2. BASED ON 100 PSI INTERNAL PRESSURE.
3. LENGTH REFERS TO THE AMOUNT OF PIPE WHICH MUST BE TIED TOGETHER.
4. FOR LENGTH OF RESTRAINED PIPE AT DIFFERENT TEST PRESSURES, USE THE FOLLOWING EQUATION:
5. IF A VALVE IS WITHIN DISTANCE "L" OF A FITTING. THE VALVE MUST BE TIED TO THAT FITTING.
6. CROSSES MUST BE RESTRAINED IN ALL APPLICABLE DIRECTIONS.
7. LENGTH OF RESTRAINED PIPE CHART IS ALSO FOR THE LENGTH OF JOINT RESTRAINT FOR MEGALUGS, OR OTHER RESTRAINT SYSTEM.

LENGTH OF RESTRAINED PIPE = (TEST PRESSURE/100 PSI) x (TABLE VALUE)

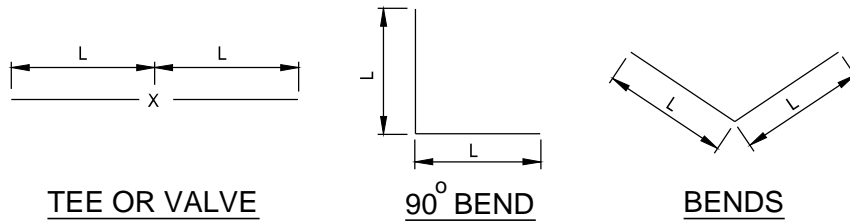

STANDARD THRUST BLOCKS

TOWN OF ELIZABETH	
MECHANICAL THRUST RESTRAINT	
SCALE: NTS	DATE: APRIL 2025
LAST REVISED: FEBRUARY 2017	
W4	
WATER AND SEWER STANDARDS	

2/14/17 12:08 ARC56862 R19 P:\0 - MASTER DETAILS\OTHER FIRMS DETAILS\W5-TRACER WIRE.DWG IMAGES: P:\0 - MASTER DETAILS\OTHER FIRMS DETAILS\ELIZABETH\STANDARD DETAILS\ELIZABETH.JPG;

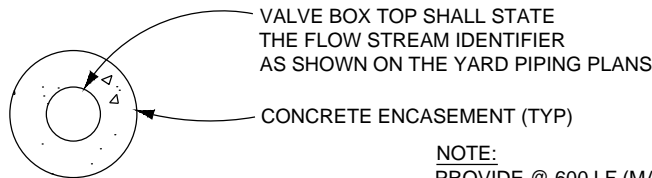
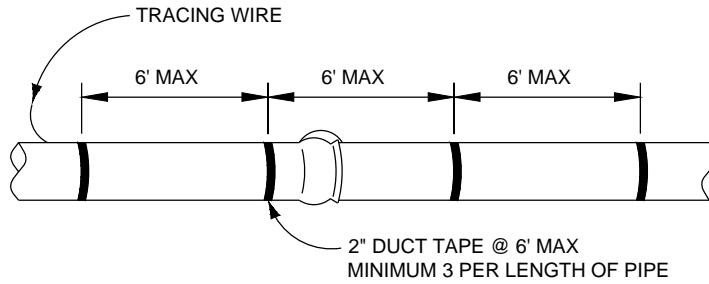
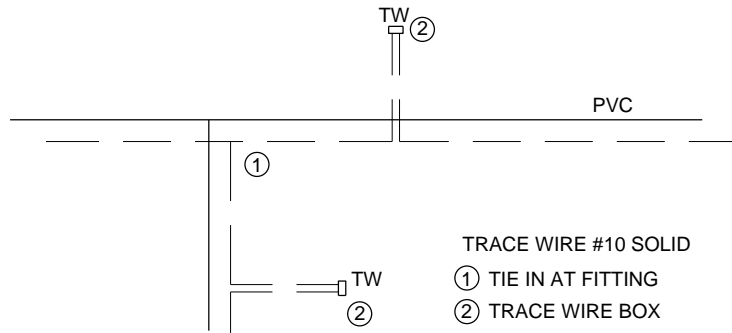

NOTE:
PROVIDE @ 600 LF (MAX) SPACING AND
AT ALL VALVES.

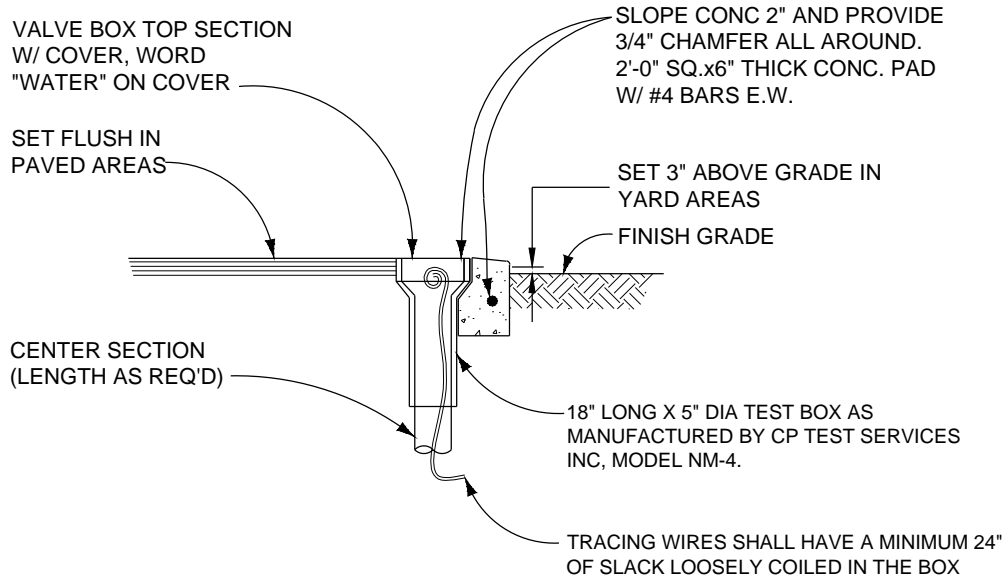

VALVE BOX PAD

 TOWN OF ELIZABETH	
TRACER WIRE	
SCALE: NTS	DATE: APRIL 2025
LAST REVISED: FEBRUARY 2017	
W5	
WATER AND SEWER STANDARDS	

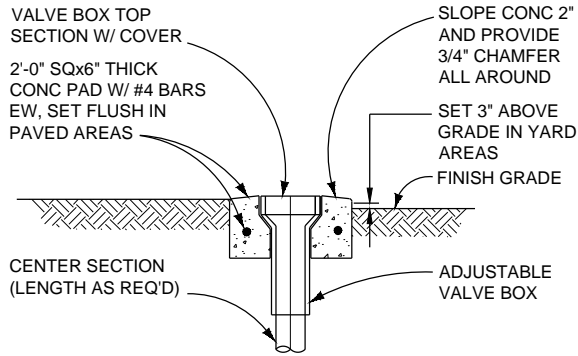

VALVE BOX PAD

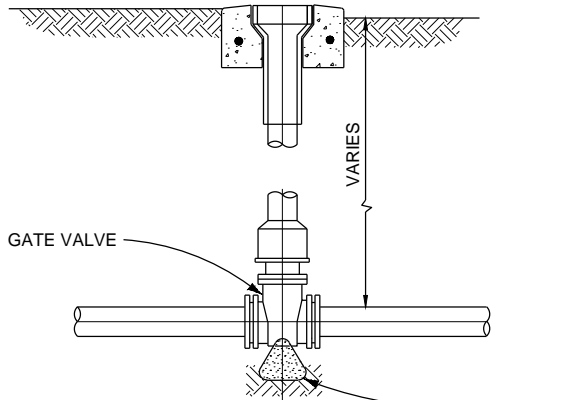

VALVE BOX

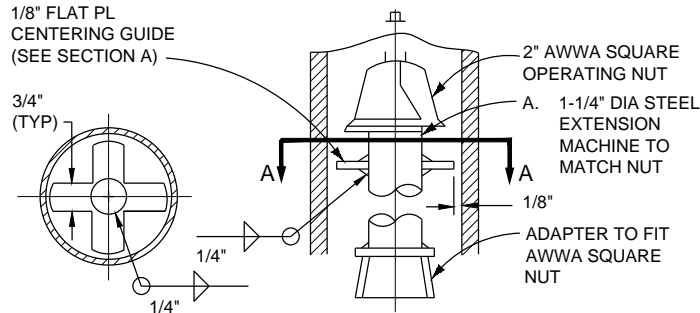
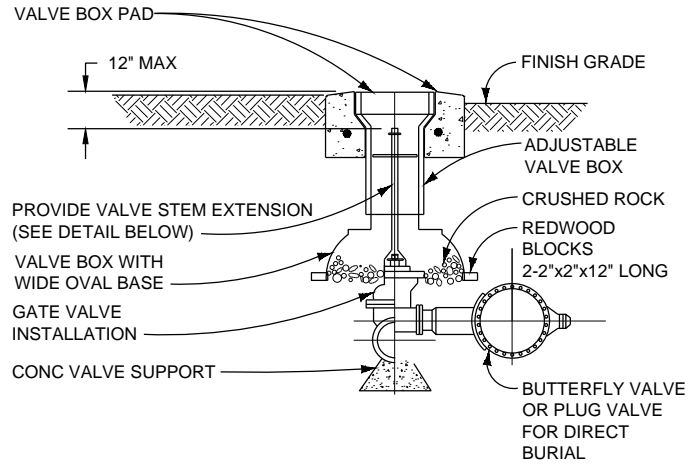

SECTION A

NOTE:
1. PROVIDE PROTECTIVE COATING TO EXTERIOR SURFACES OF VALVE BODY, VALVE BOX, EXTENSION STEM AND APPURTENANCES.

BURIED VALVE INSTALLATION

 TOWN OF ELIZABETH	
BURIED VALVES	
SCALE: NTS	DATE: APRIL 2025
LAST REVISED: FEBRUARY 2017	
W6	
WATER AND SEWER STANDARDS	

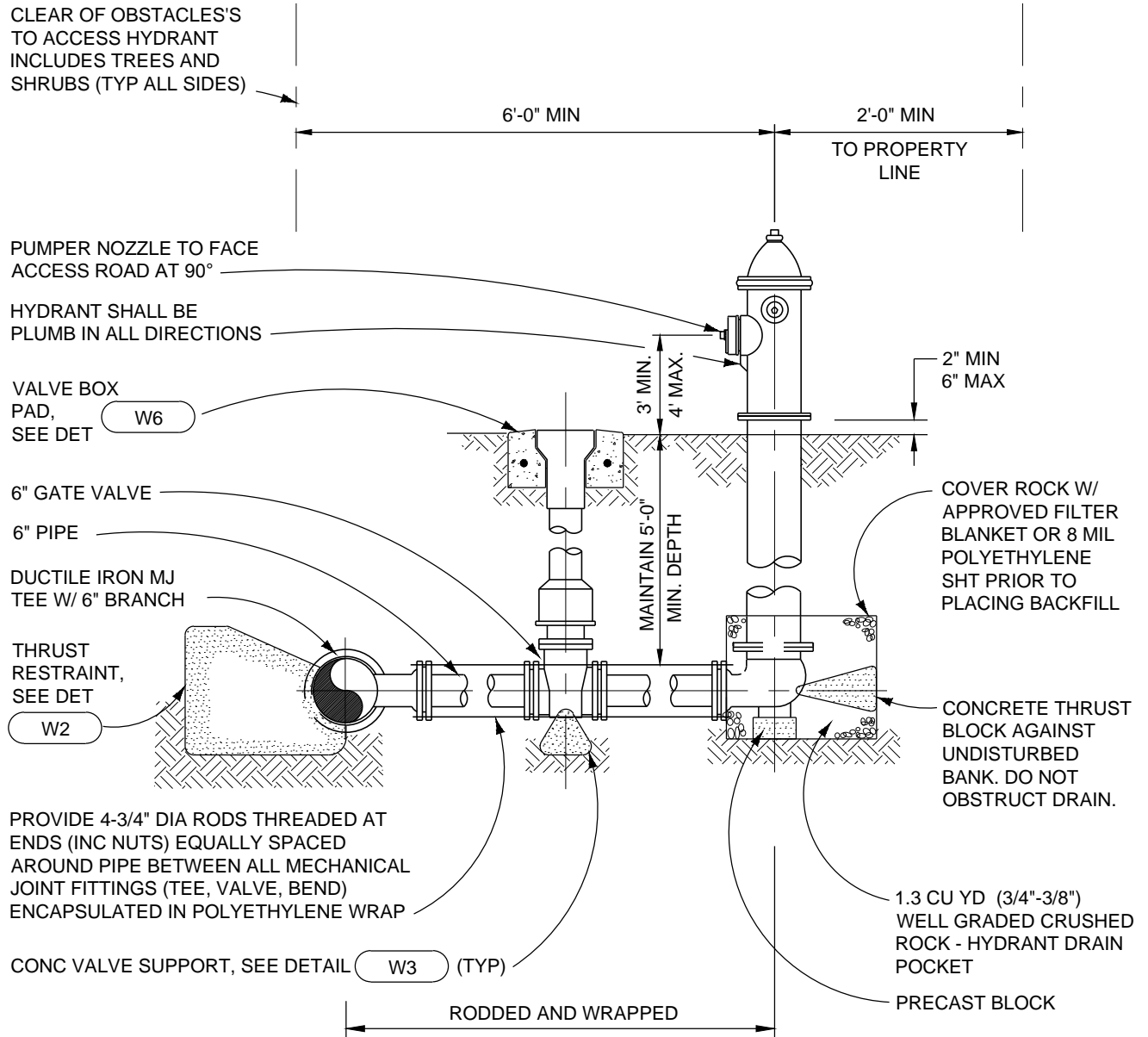

FIRE HYDRANT
NTS

 TOWN OF ELIZABETH	
FIRE HYDRANT	
SCALE: NTS	DATE: APRIL 2025
LAST REVISED: FEBRUARY 2017	
W7	
WATER AND SEWER STANDARDS	

2/14/17 13:26 ARC56862 R19 P:\0 - MASTER DETAILS\OTHER FIRMS DETAILS\ELIZABETH STANDARD DETAILS\ELIZABETH\ELIZABETH.JPG

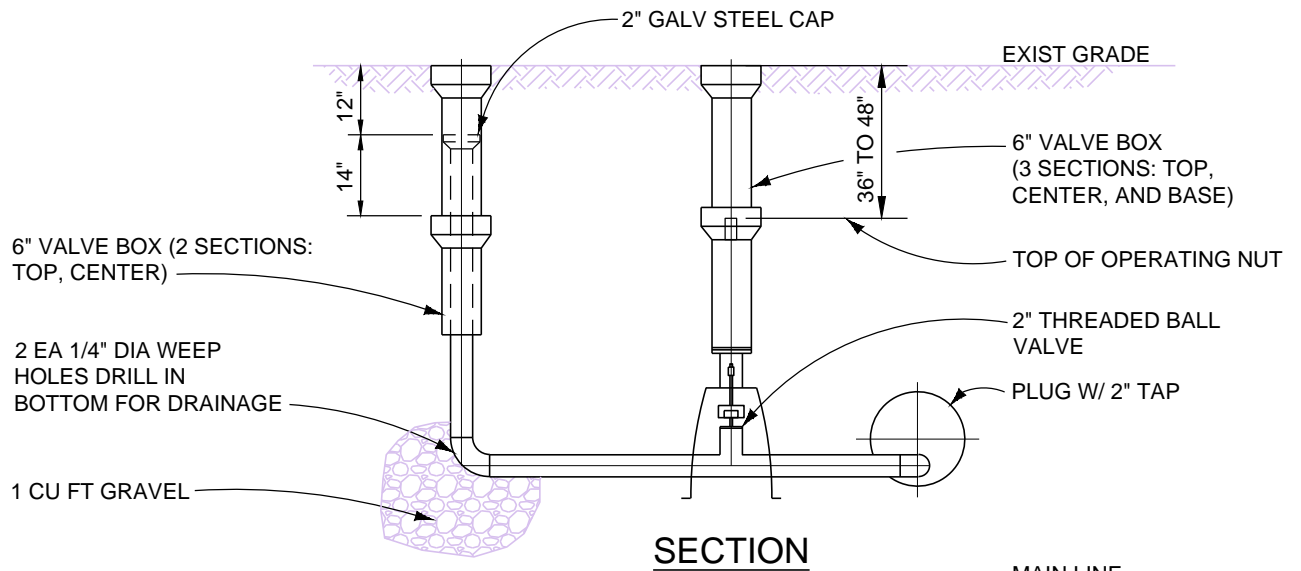

SECTION

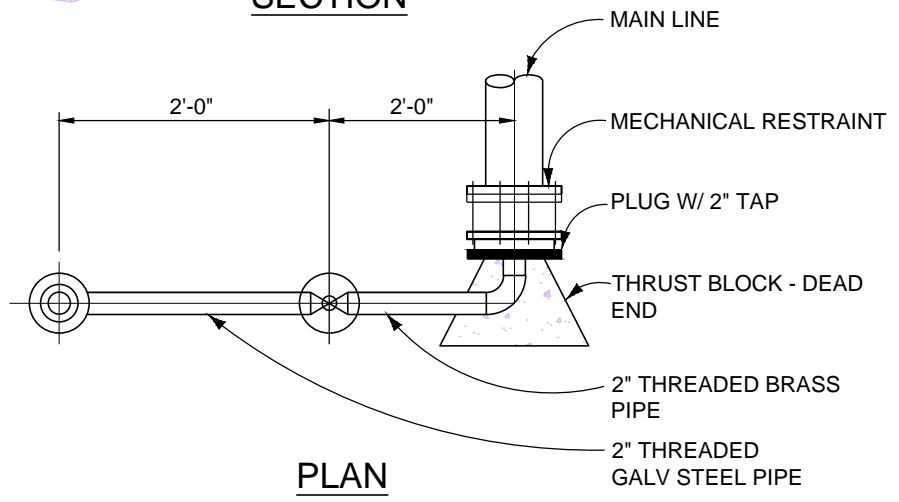

PLAN

BLOWOFF
NTS

 TOWN OF ELIZABETH	
BLOW-OFF	
SCALE: NTS	DATE: APRIL 2025
LAST REVISED: FEBRUARY 2017	
W8	
WATER AND SEWER STANDARDS	

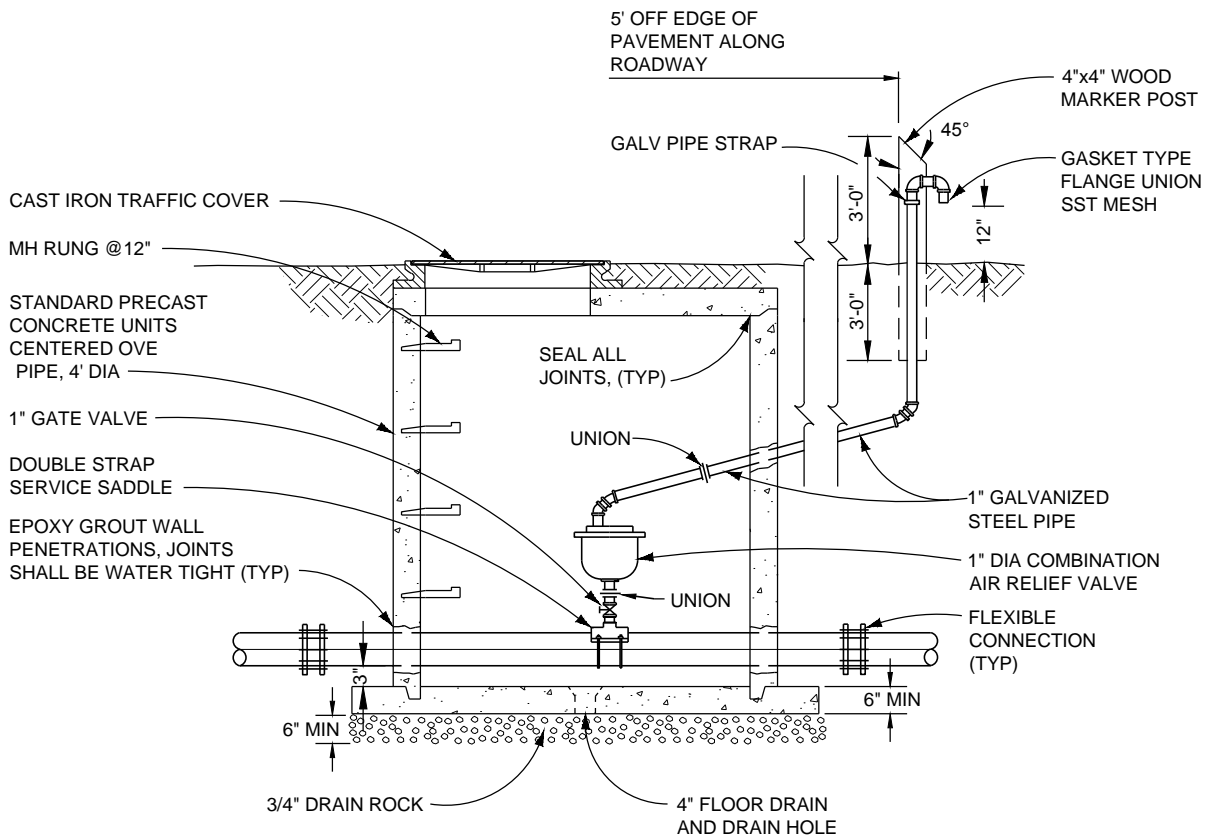

 TOWN OF ELIZABETH	
AIR REFIEF VALVE	
SCALE: NTS	DATE: APRIL 2025
LAST REVISED: FEBRUARY 2017	
W9	
WATER AND SEWER STANDARDS	

STANDARD DETAILS – SERVICE LINES

- NOTES:**
1. DOUBLE GRADE CLEANOUTS (SEE DWG L3).
 2. WHERE A WYE IS INSTALLED WITHOUT A CONNECTION TO A CUSTOMER, AN APPROVED CAP, PLUG, OR STOPPER SHALL BE INSTALLED. THE END OF THE LATERAL WITH A 2"x4" REDWOOD STAKE, EXTENDING 12" ABOVE FINISHED GRADE.
 3. ANY SERVICE THAT REQUIRES CROSSING ADJACENT PRIVATE PROPERTY WILL REQUIRE A DEDICATED EASEMENT AND MUST BE APPROVED BY THE TOWN.

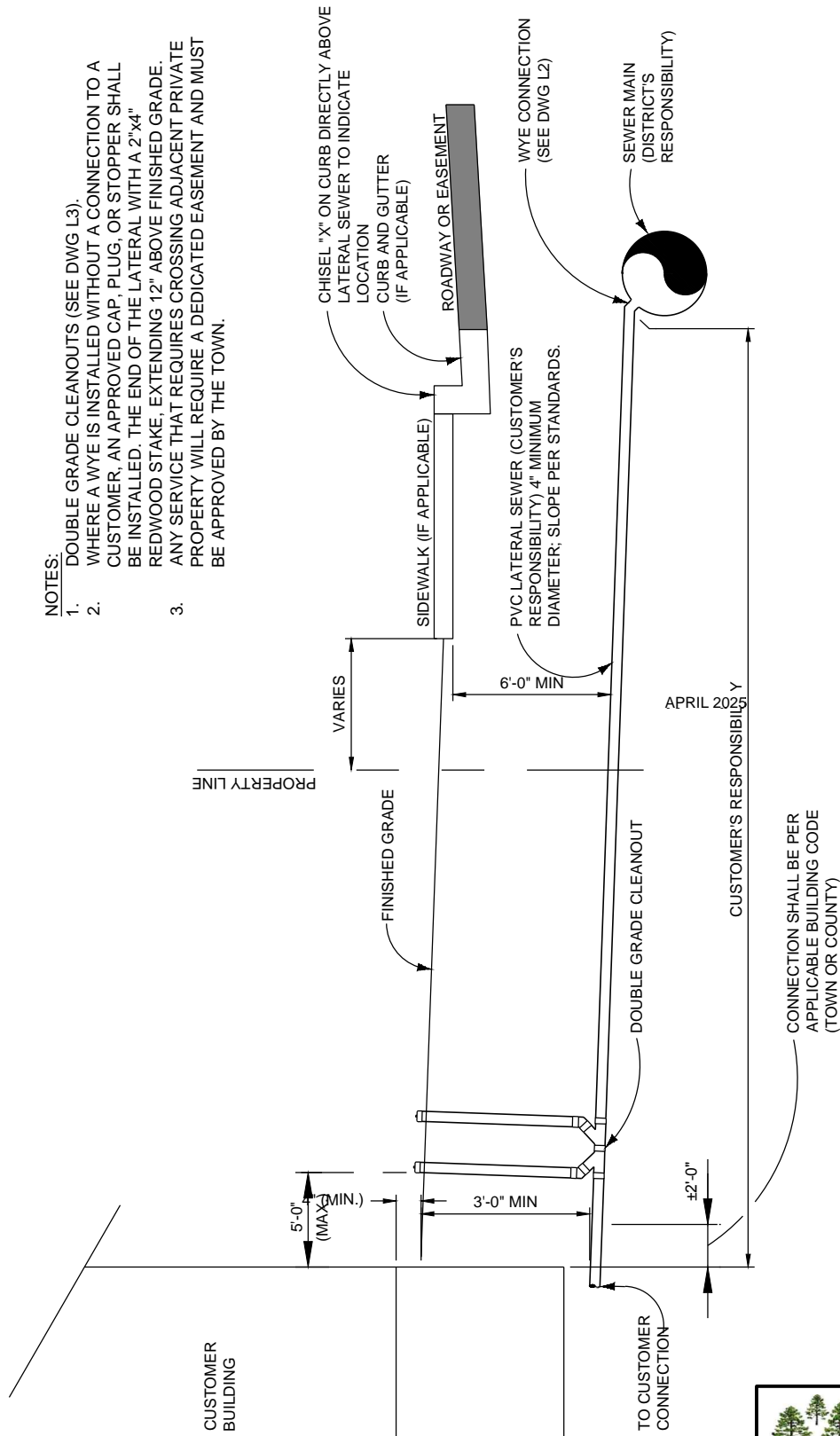

 TOWN OF ELIZABETH	
TYPICAL RESIDENTIAL SEWER SERVICE	
SCALE: NTS	DATE: APRIL 2025
LAST REVISED: FEBRUARY 2017	L1
WATER AND SEWER STANDARDS	

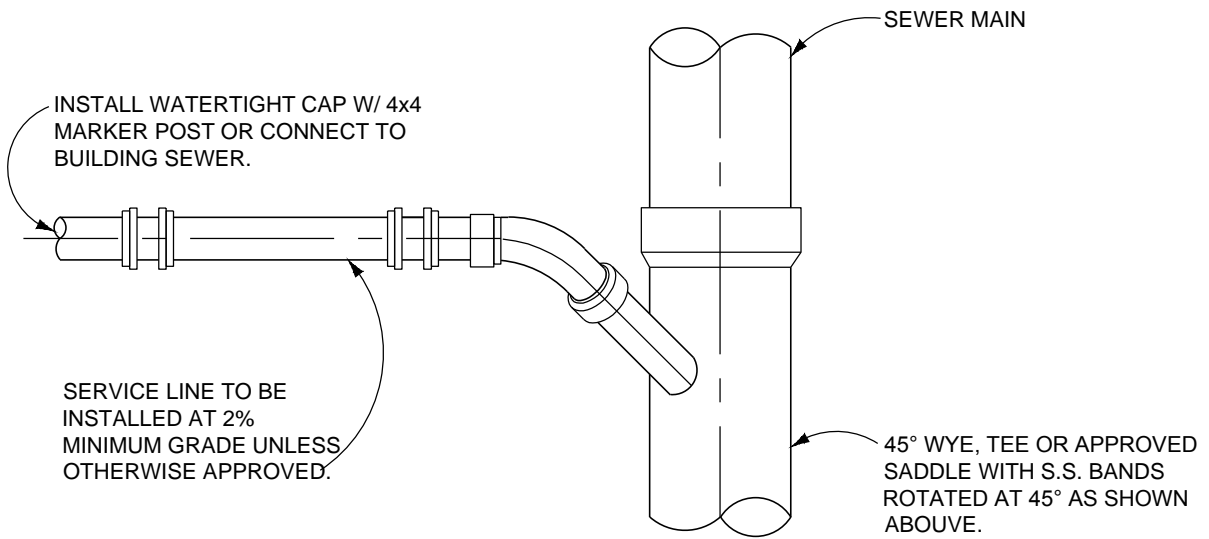
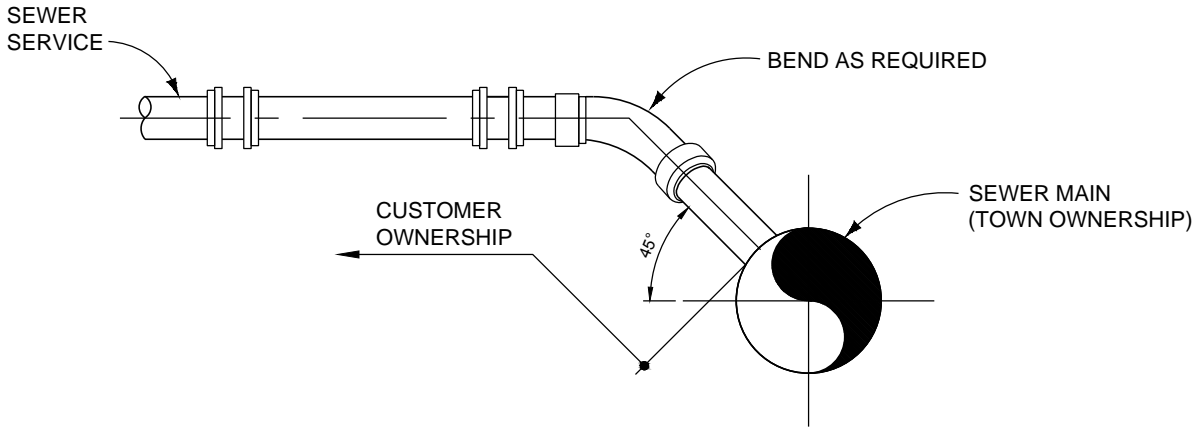

 TOWN OF ELIZABETH	
SEWER SERVICE WYE CONNECTION	
SCALE: NTS	DATE: APRIL 2025
LAST REVISED: FEBRUARY 2017	
L2	
WATER AND SEWER STANDARDS	

IMAGES: P:\0 - MASTER DETAILS\OTHER FIRMS DETAILS\ELIZABETH STANDARD DETAILS\CLEAN OUT.JPG; 2/14/17 13:24 ARC56862 R19 P:\0 - MASTER DETAILS\OTHER FIRMS DETAILS\ELIZABETH STANDARD DETAILS\L3-SERVICE LINE_CLEANOUT_DETAIL.DWG

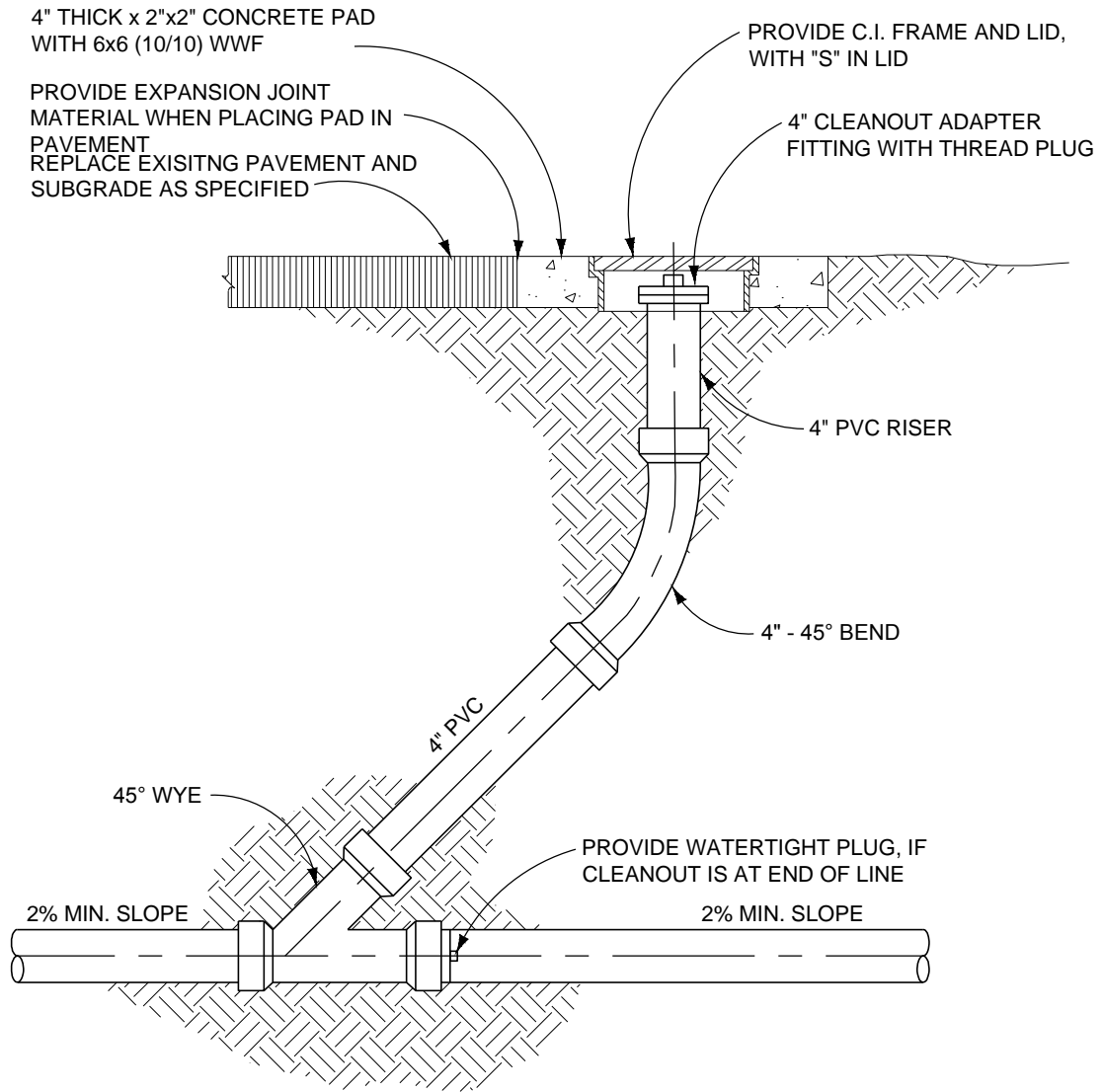

NOTE:

1. BEND & WYE TO BE GASKETED, NO GLUE JOINTS. PIPE MATERIAL AS SPECIFIED FOR SERVICE LINE.
2. FOR LOCATIONS IN PRIVATE LANDSCAPING AREA TERMINATE CLEANOUT 4" ABOVE GRADE. CAST IRON COVER NOT REQUIRED.

 TOWN OF ELIZABETH	
SEWER SERVICE LINE CLEANOUT	
SCALE: NTS	DATE: APRIL 2025
LAST REVISED: FEBRUARY 2017	
WATER AND SEWER STANDARDS	
L3	

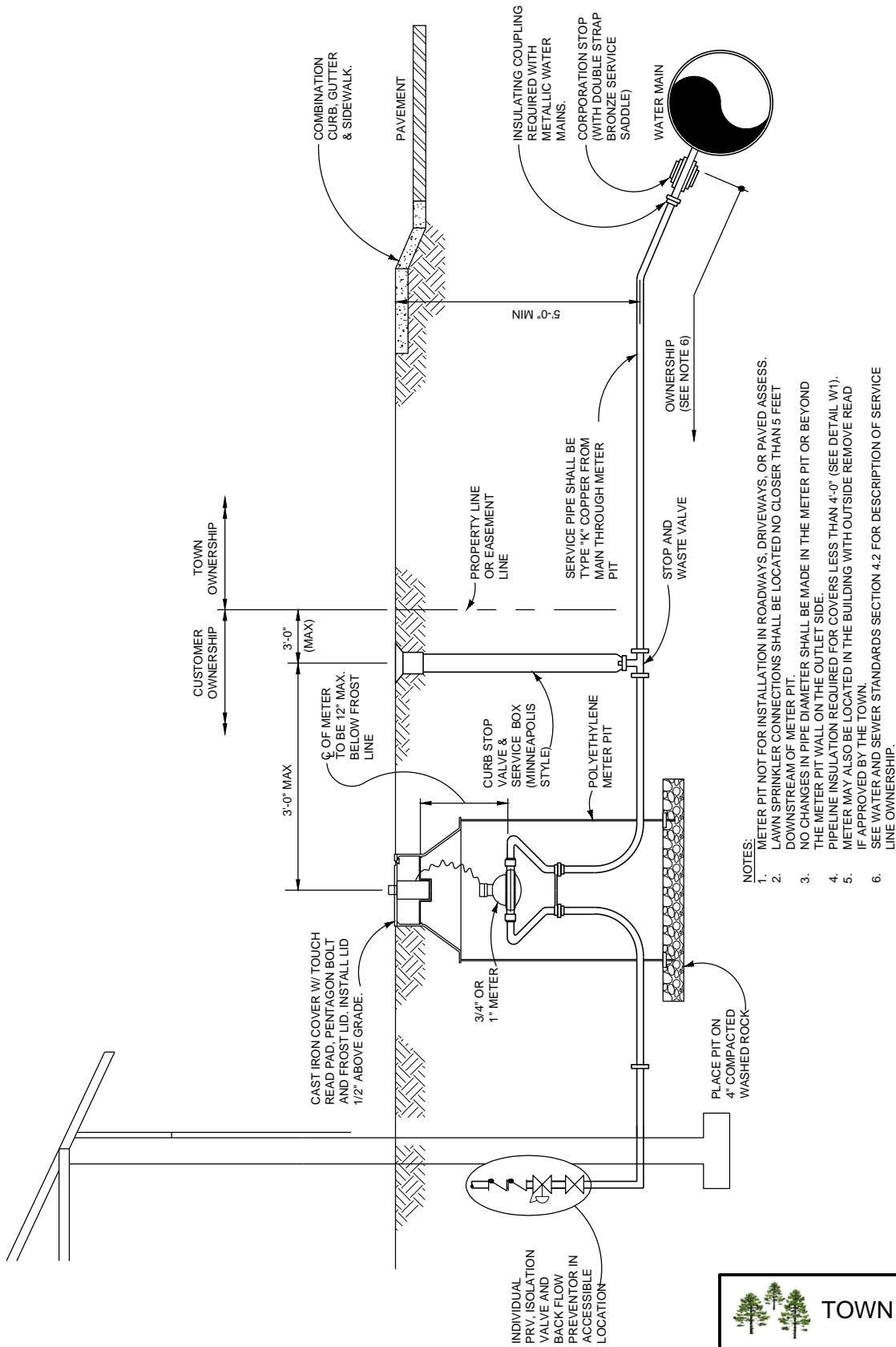

- NOTES:
- METER PIT NOT FOR INSTALLATION IN ROADWAYS, DRIVEWAYS, OR PAVED ASSESS. LAWN SPRINKLER CONNECTIONS SHALL BE LOCATED NO CLOSER THAN 5 FEET DOWNSTREAM OF METER PIT.
 - NO CHANGES IN PIPE DIAMETER SHALL BE MADE IN THE METER PIT OR BEYOND THE METER PIT WALL ON THE OUTLET SIDE.
 - PIPELINE INSULATION REQUIRED FOR COVERS LESS THAN 4'-0" (SEE DETAIL W1).
 - METER MAY ALSO BE LOCATED IN THE BUILDING WITH OUTSIDE REMOVE READ IF APPROVED BY THE TOWN.
 - SEE WATER AND SEWER STANDARDS SECTION 4.2 FOR DESCRIPTION OF SERVICE LINE OWNERSHIP.

 TOWN OF ELIZABETH	
TYPICAL SINGLE FAMILY DETACHED RESIDENTIAL WATER SERVICE	
SCALE: NTS	DATE: APRIL 2025
LAST REVISED: FEBRUARY 2017	
L4	
WATER AND SEWER STANDARDS	