

# CENTRAL TRUCK CENTER, INC.

925 Merritt Blvd. Dundalk, Maryland. 21222. 800.492.0709



# KENWORTH

Central Truck Center, Inc.  
925 Merritt Blvd  
Dundalk, MD 21222  
UEI: RN6HGRAGBK17  
CAGE: 4EJX8

## Purchase of One Dump Truck- Revised

Effingham County

Central Truck Center, Inc. is pleased to present the following bid for Effingham County, GA, for a new 2027 Ford F-750 Dump Truck.

The total price for this unit, delivered, is \$106,314.56.

This includes a standard warranty, along with the hydraulic brakes.

The truck would be available in approximately seven (7) months from the date of award.

There is an optional extended warranty that is not included in the above listed price for an additional \$3895.00 that is for 5 years, 150,000 miles that extends the basic powertrain and exhaust after treatment components for 5 year, 150,000 miles. That total amounts to \$110,209.56.

The additional pages that follow provide the equipment specifications, based on the bid requirements, along with the body specifications.

## Prepared for:

ALL ROADS TRUCKS

Prepared by: Chris Crocker

03/20/2026



Norris Ford | 901 Merritt Blvd Baltimore Maryland | 212221491

## 2027 F-750 Diesel Regular Cab Base (F7D)

Price Level: 715 | Quote ID: 10DMP750GA

# Selected Equip & Specs

### Dimensions

- GCWR: 50,000 lbs.
- Rear brake diameter: 15.0"
- Vehicle body length: 246.0"
- \* **Vehicle body height: 95.2"**
- Turning radius (to curb): 21.9'
- Rear track: 72.6"
- Rear tire outside width: 96.0"
- \* **Frame section modulus: 14.2 cu.in.**
- \* **Frame rail depth: 10.1"**
- \* **Frame rail thickness: .3"**
- Front bumper to front axle: 39.0"
- Leg room first-row: 41.4"
- Hip room first-row: 67.6"
- Front brake diameter: 15.0"
- Driver distance from axle: 54.4"
- Vehicle body width: 96.7"
- Wheelbase: 158.0"
- Front track: 83.8"
- Cab to axle: 84.0"
- Axle to end of frame: 49.0"
- \* **Frame yield strength (psi): 120000.0**
- \* **Frame rail width: 3.6"**
- Frame rail section: 9.5"
- Headroom first-row: 40.7"
- Shoulder room first-row: 68.0"

### Powertrain

- Compression ignition system
- Engine cylinders: V-8
- Torque: 800 lb.-ft. @1500 RPM
- Engine retarder system
- Fuel/water separator
- 75 mph speed limiter
- Rear-wheel drive
- Low-speed ABS traction control
- 6.7L V-8 diesel direct injection, intercooled turbo, diesel, engine with 270HP
- Horsepower: 270 HP @2400 RPM
- Radiator
- Auxiliary power take-off
- RNDM shift indicator
- 10-speed automatic
- Recommended fuel: diesel
- Standard rear differential

### Fuel Economy and Emissions

- Federal emissions

### Suspension and Handling

- Standard ride suspension
- Gas-pressurized front shock absorbers

### Driveability

- Hydraulic disc brakes
- 4-wheel antilock (ABS) brakes
- Hill Start Assist
- Leaf spring front suspension
- Rigid axle rear suspension
- Hydraulic power-assist steering system
- 2-wheel steering system
- Front and rear ventilated disc brakes
- Four channel ABS brakes
- Rigid axle front suspension
- Tapered leaf front suspension
- Leaf spring rear suspension
- Re-circulating ball steering

Prices and content availability as shown are subject to change and should be treated as estimates only. Actual base vehicle, package and option pricing may vary from this estimate because of special local pricing, availability or pricing adjustments not reflected in the dealer's computer system. See salesperson for the most current information.

## Prepared for:

ALL ROADS TRUCKS

Prepared by: Chris Crocker

03/20/2026



Norris Ford | 901 Merritt Blvd Baltimore Maryland | 212221491

## 2027 F-750 Diesel Regular Cab Base (F7D)

Price Level: 715 | Quote ID: 10DMP750GA

# Selected Equip & Specs (cont'd)

## Body Exterior

- \* **Trailer wiring harness**
- 2 doors
- Black side window trim
- Black windshield trim
- 2 front tow hooks
- Black grille
- Convex spotter in driver and passenger side door mirrors
- Black door mirrors
- 22.5 x 8.25-inch front and dual rear wheels
- Steel front wheels
- Steel rear wheels
- Side assist steps
- Monotone paint
- Black door handles
- Black front bumper
- Straight front bumper ends
- Hood mounted grille
- Trailer style side mirrors
- English measure truck 279/82R22.5 AS BSW front and rear tires
- White front wheels
- White rear wheels
- Disc rear wheel

## Convenience

- \* **Power door locks with 2 stage unlocking**
- \* **Auto-locking doors**
- \* **Power first-row windows**
- Driver foot rest
- Front beverage holders
- 2 beverage holders
- Instrument panel bin
- Trip computer
- Dual electric horn
- \* **Keyfob activated door locks**
- Cruise control with steering wheel mounted controls
- Partial floor console
- Fixed rear windshield
- Standard glove box
- \* **Driver and passenger door bins**
- Dashboard storage
- Upfitter switches
- Steering column lever gearshift location

## Comfort

- Manual climate control
- Full headliner coverage
- Full floor coverage
- Manual tilting steering wheel
- Cloth headliner material
- Full vinyl floor covering
- Urethane steering wheel
- Manual telescopic steering wheel

## Seats and Trim

- Seating capacity: 2
- Front passenger seat armrest
- Folding driver seat back
- 4 driver seats way-direction
- Bucket passenger seat
- Low passenger seat back
- Manual fore/aft
- Driver seat armrest
- Bucket driver seat
- Low driver seat back
- Manual fore/aft
- Fixed passenger seat back
- 2 passenger seats way-direction
- Vinyl front seat upholstery

Prices and content availability as shown are subject to change and should be treated as estimates only. Actual base vehicle, package and option pricing may vary from this estimate because of special local pricing, availability or pricing adjustments not reflected in the dealer's computer system. See salesperson for the most current information.

**Prepared for:**

ALL ROADS TRUCKS

Prepared by: Chris Crocker

03/20/2026



Norris Ford | 901 Merritt Blvd Baltimore Maryland | 212221491

**2027 F-750 Diesel Regular Cab Base (F7D)**

Price Level: 715 | Quote ID: 10DMP750GA

## Selected Equip & Specs (cont'd)

### Entertainment Features

- AM/FM
- AM radio
- Seek scan
- External memory control
- Speakers number: 2
- Wireless audio streaming
- In-vehicle audio
- FM radio
- Auxiliary input jack
- Standard grade speakers
- Steering wheel mounted audio controls
- Fixed audio antenna

### Lighting, Visibility and Instrumentation

- Analog instrumentation display
- Digital clock
- Tachometer
- Engine/electric motor temperature gauge
- Oil temperature gauge
- Engine hour meter
- Light tinted windows
- Halogen headlights
- Multiple enclosed headlights
- Variable intermittent front windshield wipers
- \* **Illuminated entry**
- Variable instrument panel light
- Cab clearance lights
- Trip odometer
- Driver information center
- Oil pressure gauge
- \* **Voltmeter**
- Transmission fluid temperature gauge
- Diesel exhaust fluid (def) gauge
- Reflector headlights
- Auto on/off headlight control
- Delay-off headlights
- Speed sensitive wipers
- Front reading lights
- Daytime running lights
- Delay interior courtesy lights

### Technology and Telematics

- Handsfree wireless device connectivity
- 1 USB port

### Safety and Security

- Vehicle tracker
- Electronic stability control system
- \* **Remote panic alarm**
- \* **Back-up alarm**

### Dimensions

#### General Weights

* <b>Curb weight</b> .....	<b>9,969 lbs.</b>	* <b>Rear curb weight</b> .....	<b>3,701 lbs.</b>
Front GAWR .....	12000 lbs.	Rear GAWR .....	21000 lbs.
GVWR .....	25999 lbs.	GCWR .....	50000 lbs.

#### Trailer Weights

GCWR ..... 50,000 lbs.

#### Weights

Prices and content availability as shown are subject to change and should be treated as estimates only. Actual base vehicle, package and option pricing may vary from this estimate because of special local pricing, availability or pricing adjustments not reflected in the dealer's computer system. See salesperson for the most current information.

## Prepared for:

ALL ROADS TRUCKS

Prepared by: Chris Crocker

03/20/2026



Norris Ford | 901 Merritt Blvd Baltimore Maryland | 212221491

## 2027 F-750 Diesel Regular Cab Base (F7D)

Price Level: 715 | Quote ID: 10DMP750GA

### Selected Equip & Specs (cont'd)

Maximum GVWR ..... 37,000 lbs.

\* **Nominal RBM (in.-lbs.)** ..... 1,701,600 nominal RBM (in.-lbs.)

\* **Max RBM (in.-lbs.)** ..... 1,780,800 max RBM (in.-lbs.)

#### Front Weights

\* **Front curb weight** ..... 6,268 lbs.

\* **Spring rating front** ..... 12,000 lbs.

\* **Axle capacity front** ..... 12,000 lbs.

Tire/wheel capacity front ..... 13,220 lbs.

#### Rear Weights

Axle capacity rear ..... 21,000 lbs.

Tire/wheel capacity rear ..... 24,040 lbs.

Spring rating rear ..... 21,000 lbs.

#### Exterior Measurements

Vehicle body length ..... 246.0"

\* **Vehicle body height** ..... 95.2"

Front brake diameter ..... 15.0"

Rear brake diameter ..... 15.0"

Rear frame height loaded ..... 36.5"

Turning radius (to bumper) ..... 23.5'

Width - mirrors extended ..... 121.9"

Rear track ..... 72.6"

Turning radius (to curb) ..... 21.9'

Rear tire outside width ..... 96.0"

\* **Frame section modulus** ..... 14.2 cu.in.

\* **Frame rail depth** ..... 10.1"

\* **Frame rail thickness** ..... .3"

Front bumper to front axle ..... 39.0"

Vehicle body width ..... 96.7"

Wheelbase ..... 158.0"

\* **Front frame height loaded** ..... 35.3"

\* **Front frame height unloaded** ..... 37.4"

Rear frame height unloaded ..... 38.0"

Width - mirrors folded ..... 90.7"

Front track ..... 83.8"

Driver distance from axle ..... 54.4"

Cab to axle ..... 84.0"

Axle to end of frame ..... 49.0"

\* **Frame yield strength (psi)** ..... 120000.0

\* **Frame rail width** ..... 3.6"

Frame rail section ..... 9.5"

#### Headroom

Headroom first-row ..... 40.7"

#### Legroom

Leg room first-row ..... 41.4"

#### Shoulder Room

Shoulder room first-row ..... 68.0"

#### Hip Room

Hip room first-row ..... 67.6"

*Front And Rear GAWR Total Will Exceed Overall GVWR*

### Powertrain

Prices and content availability as shown are subject to change and should be treated as estimates only. Actual base vehicle, package and option pricing may vary from this estimate because of special local pricing, availability or pricing adjustments not reflected in the dealer's computer system. See salesperson for the most current information.

**Prepared for:**

ALL ROADS TRUCKS

Prepared by: Chris Crocker

03/20/2026



Norris Ford | 901 Merritt Blvd Baltimore Maryland | 212221491

**2027 F-750 Diesel Regular Cab Base (F7D)**

Price Level: 715 | Quote ID: 10DMP750GA

**Selected Equip & Specs (cont'd)**

*Engine*

Engine	6.7L V-8 diesel direct injection, intercooled turbo, diesel, engine with 270HP	Valves per cylinder	4
Engine cylinders	V-8	Engine location	Front mounted engine
Ignition	Compression ignition system	Engine mounting direction	Longitudinal mounted engine
Engine block material	Iron engine block	Cylinder head material	Aluminum cylinder head

*Engine Specs*

Displacement	6.7L	cc	405.9 cu.in.
Bore	3.9"	Stroke	4.25"
Compression ratio	16.2	Governed RPM	3200 RPM

*Engine Power*

Horsepower	270 HP@2400 RPM	Torque	800 lb.-ft.@1500 RPM
------------	-----------------	--------	----------------------

*Alternator*

Alternator amps	195A	Alternator type	Heavy-duty alternator
-----------------	------	-----------------	-----------------------

*Battery*

Battery type	Dual lead acid battery	Battery rating	1500CCA
Battery step	Battery step	Battery location	Battery location forward right
Battery run down protection	Battery run down protection		

*Engine Extras*

Radiator	Radiator	Fuel/water separator	Fuel/water separator
Auxiliary power take-off	Auxiliary power take-off	Engine retarder	Engine retarder system
Shift indicator	RNDM shift indicator		

*Transmission*

Transmission	10-speed automatic	Transmission electronic control	Transmission electronic control
Speed limiter	75 mph speed limiter	Overdrive transmission	Overdrive transmission
Lock-up transmission	Lock-up transmission	First gear ratio	4.615
Second gear ratio	2.919	Third gear ratio	2.132
Fourth gear ratio	1.773	Fifth gear ratio	1.519
Sixth gear ratio	1.277	Reverse gear ratio	4.695
Seventh gear ratio	1	Eighth gear ratio	0.851
Ninth gear ratio	0.687	Tenth gear ratio	0.632
Stall ratio	1.97	Selectable mode transmission	Tow/Haul Mode selectable mode transmission
Sequential shift control	Sequential shift control	Transmission oil cooler	Transmission oil cooler
PTO transmission provision	PTO transmission provision		

Prices and content availability as shown are subject to change and should be treated as estimates only. Actual base vehicle, package and option pricing may vary from this estimate because of special local pricing, availability or pricing adjustments not reflected in the dealer's computer system. See salesperson for the most current information.

**Prepared for:**

ALL ROADS TRUCKS

Prepared by: Chris Crocker

03/20/2026



Norris Ford | 901 Merritt Blvd Baltimore Maryland | 212221491

**2027 F-750 Diesel Regular Cab Base (F7D)**

Price Level: 715 | Quote ID: 10DMP750GA

**Selected Equip & Specs (cont'd)**

*Drive Type*

Drive type ..... Rear-wheel drive

*Drivetrain*

\* Axle ratio ..... **6.17** Axle speed ..... Single axle speed

*Exhaust*

Tailpipe ..... Aluminized steel single exhaust Additional muffler type ..... horizontal  
Additional muffler location ..... right Additional tailpipe type ..... horizontal  
Additional tailpipe location ..... right

*Fuel*

Fuel type ..... diesel

*Fuel Tank*

Front left fuel tank shape ..... rectangular Front left fuel tank capacity ..... 50.01 US gallons  
DEF capacity ..... 8.00 gal.

*Drive Feature*

Traction control ..... Low-speed ABS traction control Differential ..... Standard rear differential

**Fuel Economy and Emissions**

*Emissions*

Emissions ..... Federal emissions

**Suspension and Handling**

*Suspension*

Suspension ..... Standard ride suspension Front shock absorbers ..... Gas-pressurized front shock absorbers

**Driveability**

*Brakes*

Brake type ..... Hydraulic disc brakes Ventilated brakes ..... Front and rear ventilated disc brakes  
ABS brakes ..... Four channel ABS brakes ABS brakes ..... 4-wheel antilock (ABS) brakes

*Brake Assistance*

Hill start assist ..... Hill Start Assist

*Front Suspension*

Suspension ride type front Rigid axle front suspension Suspension type front ..... Leaf spring front suspension

*Front Spring*

Regular front springs ..... Regular front springs Springs front ..... Tapered leaf front suspension

Prices and content availability as shown are subject to change and should be treated as estimates only. Actual base vehicle, package and option pricing may vary from this estimate because of special local pricing, availability or pricing adjustments not reflected in the dealer's computer system. See salesperson for the most current information.

**Prepared for:**

ALL ROADS TRUCKS

Prepared by: Chris Crocker

03/20/2026



Norris Ford | 901 Merritt Blvd Baltimore Maryland | 212221491

**2027 F-750 Diesel Regular Cab Base (F7D)**

Price Level: 715 | Quote ID: 10DMP750GA

**Selected Equip & Specs (cont'd)**

*Rear Spring*

Springs rear ..... Multi-leaf rear suspension  
Auxiliary rear spring ..... Rubber auxiliary rear spring

Rear springs ..... Regular grade rear springs

*Rear Suspension*

Suspension type rear .... Leaf spring rear suspension

Suspension ride type rear . Rigid axle rear suspension

*Steering*

Steering ..... Hydraulic power-assist steering system  
Steering type number of wheels ..... 2-wheel steering system

Steering type ..... Re-circulating ball steering

**Exterior**

*Front Wheels*

Front wheels diameter ..... 22.5"

Front wheels width ..... 8.3"

*Rear Wheels*

Rear wheels diameter ..... 22.5"

Rear wheels width ..... 8.3"

*Front And Rear Wheels*

Appearance ..... none

*Front Tires*

Aspect ..... 82  
Sidewalls ..... BSW  
Type ..... english measure truck tire  
Front wheel - RPM ..... 497

Diameter ..... 22.5"  
Tread ..... AS  
Width ..... 279mm

*Rear Tires*

Aspect ..... 82  
Sidewalls ..... BSW  
Type ..... english measure truck tire  
Rear wheel - RPM ..... 497

Diameter ..... 22.5"  
Tread ..... AS  
Width ..... 279mm

**Body Exterior**

*Trailer*

\* Towing wiring harness ..... Trailer wiring harness

*Exterior Features*

Number of doors ..... 2 doors  
Front splash guards ..... Front splash guards

Side steps ..... Side assist steps

*Frame*

Clean CA frame ..... Clean CA frame

Prices and content availability as shown are subject to change and should be treated as estimates only. Actual base vehicle, package and option pricing may vary from this estimate because of special local pricing, availability or pricing adjustments not reflected in the dealer's computer system. See salesperson for the most current information.

**Prepared for:**

ALL ROADS TRUCKS

Prepared by: Chris Crocker

03/20/2026



Norris Ford | 901 Merritt Blvd Baltimore Maryland | 212221491

**2027 F-750 Diesel Regular Cab Base (F7D)**

Price Level: 715 | Quote ID: 10DMP750GA

**Selected Equip & Specs (cont'd)**

*Body*

Body panels . . . Composite and galvanized steel body panels

*Mirrors*

Convex spotter . . . . . Convex spotter in driver and passenger side door mirrors

*Tires*

Front tires LT load rating . . . . . H

Rear tires LT load rating . . . . . H

*Wheels*

Front wheel type . . . . . Disc front wheel  
Number of front wheel studs . . . . . 10 front wheel studs

Dual rear wheels . . . . . Dual rear wheels  
Number of rear wheel studs . . . . . 10 rear wheel studs

**Convenience**

*Door Locks*

- \* **Door locks** . . . . . **Power door locks with 2 stage unlocking**
- \* **Auto door locks** . . . . . **Auto-locking doors**

\* **Keyfob door locks** . . . **Keyfob activated door locks**

*Cruise Control*

Cruise control . . . . . Cruise control with steering wheel mounted controls

*Exterior Mirrors*

Folding door mirrors . . . . . Manual folding door mirrors

Heated door mirrors . . . . . Heated driver and passenger side door mirrors

*Front Side Windows*

- \* **First-row windows** . . . . . **Power first-row windows**

*Floor Console*

Floor console . . . . . Partial floor console

*Passenger Visor*

Visor passenger mirror . . . . . Passenger visor mirror

*Power Outlets*

12V power outlets . . . . . 2 12V power outlets

*Pedals*

Driver foot rest . . . . . Driver foot rest

*Rear Windshield*

Rear windshield . . . . . Fixed rear windshield

Prices and content availability as shown are subject to change and should be treated as estimates only. Actual base vehicle, package and option pricing may vary from this estimate because of special local pricing, availability or pricing adjustments not reflected in the dealer's computer system. See salesperson for the most current information.

**Prepared for:**

ALL ROADS TRUCKS

Prepared by: Chris Crocker

03/20/2026



Norris Ford | 901 Merritt Blvd Baltimore Maryland | 212221491

**2027 F-750 Diesel Regular Cab Base (F7D)**

Price Level: 715 | Quote ID: 10DMP750GA

**Selected Equip & Specs (cont'd)**

*Storage*

- \* **Door bins front** ... **Driver and passenger door bins**
- Beverage holders ..... Front beverage holders
- Instrument panel storage ..... Instrument panel bin

- Number of beverage holders ..... 2 beverage holders
- Glove box ..... Standard glove box
- Dashboard storage ..... Dashboard storage

*Windows Feature*

- \* **One-touch up window** ... **Driver and passenger one-touch up windows**

- \* **One-touch down window** ... **Driver and passenger one-touch down windows**

*Miscellaneous*

- Trip computer ..... Trip computer
- Upfitter switches ..... Upfitter switches

- Gearshift location ..... Steering column lever gearshift location
- Horn ..... Dual electric horn

**Comfort**

*Climate Control*

- Climate control ..... Manual climate control

*Headliner*

- Headliner material ..... Cloth headliner material

- Headliner coverage ..... Full headliner coverage

*Floor Trim*

- Floor covering ..... Full vinyl floor covering

- Floor coverage ..... Full floor coverage

*Steering Wheel*

- Steering wheel material ..... Urethane steering wheel
- Steering wheel tilt ..... Manual tilting steering wheel

- Steering wheel telescopic. Manual telescopic steering wheel

**Seats and Trim**

*Seat Capacity*

- Seating capacity ..... 2

*Front Seats*

- Front seat type ..... Bucket driver seat
- Driver seat back ..... Folding driver seat back
- Driver seats way-direction4 driver seats way-direction
- Passenger seat back ..... Fixed passenger seat back
- Passenger seats way-direction ..... 2 passenger seats way-direction
- Armrests front driver ..... Driver seat armrest

- Front seat type ..... Bucket passenger seat
- Driver seat back type ..... Low driver seat back
- Driver seat fore/aft ..... Manual fore/aft
- Passenger seat back type ..... Low passenger seat back
- Passenger seat fore/aft ..... Manual fore/aft
- Armrests front passenger ..... Front passenger seat armrest

*Front Seat Trim*

Prices and content availability as shown are subject to change and should be treated as estimates only. Actual base vehicle, package and option pricing may vary from this estimate because of special local pricing, availability or pricing adjustments not reflected in the dealer's computer system. See salesperson for the most current information.

## Prepared for:

ALL ROADS TRUCKS

Prepared by: Chris Crocker

03/20/2026



Norris Ford | 901 Merritt Blvd Baltimore Maryland | 212221491

## 2027 F-750 Diesel Regular Cab Base (F7D)

Price Level: 715 | Quote ID: 10DMP750GA

## Selected Equip & Specs (cont'd)

Front seat upholstery ..... Vinyl front seat upholstery

Front seatback upholstery ..... Carpet front seatback upholstery

### *Gearshifter Material*

Gearshifter material ..... Urethane gear shifter material

## Entertainment Features

### *Radio Features*

Aux input jack ..... Auxiliary input jack  
Seek scan ..... Seek scan

External memory ..... External memory control

### *Speakers*

Speakers ..... Standard grade speakers

Speakers number ..... 2

### *Audio Features*

Steering mounted audio control ..... Steering wheel  
mounted audio controls

Wireless streaming ..... Wireless audio streaming

## Lighting, Visibility and Instrumentation

### *Instrumentation*

Trip odometer ..... Trip odometer

Instrumentation display ..... Analog instrumentation  
display

### *Instrumentation Displays*

Driver information center ..... Driver information center

Clock ..... Digital clock

### *Instrumentation Gauges*

Tachometer ..... Tachometer  
Oil temperature gauge ..... Oil temperature gauge

Oil pressure gauge ..... Oil pressure gauge  
Transmission temperature gauge ..... Transmission fluid  
temperature gauge

\* **Voltmeter** ..... **Voltmeter**

Engine/electric motor temperature  
gauge ..... Engine/electric motor temperature gauge  
DEF fluid gauge ..... Diesel exhaust fluid (def) gauge

Engine hour meter ..... Engine hour meter

### *Instrumentation Warnings*

Oil pressure warning ..... Oil pressure warning  
Low brake fluid warning ..... Low brake fluid warning  
Headlights on reminder ..... Headlights on reminder  
Door ajar warning ..... Door ajar warning  
Transmission fluid temperature warning  
Transmission fluid temp warning

Low fuel warning ..... Low fuel warning  
Battery charge warning ..... Battery charge warning  
Key in vehicle warning ..... Key in vehicle warning  
Service interval warning ..... Service interval indicator  
Low diesel exhaust fluid (DEF) warning ..... Low diesel  
exhaust fluid (DEF) warning

### *Glass*

Tinted windows ..... Light tinted windows

**Prepared for:**

ALL ROADS TRUCKS

Prepared by: Chris Crocker

03/20/2026



Norris Ford | 901 Merritt Blvd Baltimore Maryland | 212221491

**2027 F-750 Diesel Regular Cab Base (F7D)**

Price Level: 715 | Quote ID: 10DMP750GA

**Selected Equip & Specs (cont'd)**

*Headlights*

Headlights ..... Halogen headlights  
Auto headlights ..... Auto on/off headlight control  
Delay off headlights ..... Delay-off headlights

Headlight type ..... Reflector headlights  
Multiple headlights ..... Multiple enclosed headlights

*Front Windshield*

Wipers... Variable intermittent front windshield wipers

Speed sensitive wipers ..... Speed sensitive wipers

*Interior Lighting*

\* **Illuminated entry** ..... **Illuminated entry**  
Front reading lights ..... Front reading lights

Variable panel light ..... Variable instrument panel light

*Lights*

Running lights ..... Daytime running lights  
Clearance lights ..... Cab clearance lights

Interior courtesy lights... Delay interior courtesy lights

**Technology and Telematics**

*Connectivity*

Handsfree .... Handsfree wireless device connectivity

*USB Ports*

USB ports ..... 1 USB port

**Safety and Security**

*Security System*

\* **Remote panic alarm** ..... **Remote panic alarm**

Vehicle tracker ..... Vehicle tracker

*Traction Control*

Electronic stability control... Electronic stability control system

*Parking Sensors*

\* **Back up alarm** ..... **Back-up alarm**

Prices and content availability as shown are subject to change and should be treated as estimates only. Actual base vehicle, package and option pricing may vary from this estimate because of special local pricing, availability or pricing adjustments not reflected in the dealer's computer system. See salesperson for the most current information.

**Prepared for:**

ALL ROADS TRUCKS  
Prepared by: Chris Crocker  
03/20/2026



Norris Ford | 901 Merritt Blvd Baltimore Maryland | 212221491

---

**2027 F-750 Diesel Regular Cab Base (F7D)**

Price Level: 715 | Quote ID: 10DMP750GA

---

## Warranty

### Standard Warranty

*Basic Warranty*

Basic warranty ..... 24 months/unlimited

*Powertrain Warranty*

Powertrain warranty ..... 24 months/unlimited

*Corrosion Perforation*

Corrosion perforation warranty ..... 36 months/unlimited

*Roadside Assistance Warranty*

Roadside warranty ..... 24 months/unlimited

*Diesel Engine Warranty*

Diesel engine warranty ..... 60 months/250,000 miles

*Transmission Warranty*

Transmission warranty ..... 60 months/250,000 miles

*Frame Rail Warranty*

Frame Rail Warranty ..... 60 months/unlimited

---

Prices and content availability as shown are subject to change and should be treated as estimates only. Actual base vehicle, package and option pricing may vary from this estimate because of special local pricing, availability or pricing adjustments not reflected in the dealer's computer system. See salesperson for the most current information.

**Prepared for:**

ALL ROADS TRUCKS

Prepared by: Chris Crocker

03/20/2026



Norris Ford | 901 Merritt Blvd Baltimore Maryland | 212221491

**2027 F-750 Diesel Regular Cab Base (F7D)**

Price Level: 715 | Quote ID: 10DMP750GA

## Vehicle Dimension and Performance Summary

Performance predictions in this report represent an estimate of vehicle performance based on standard operating conditions. Variations in customer equipment, load configuration, ambient conditions, and/or operator driving techniques can cause significant variations in vehicle performance. These values are not representative of results that may be shown in actual dynamometer tests. This report should therefore be used as a guide for comparative vehicle performance.

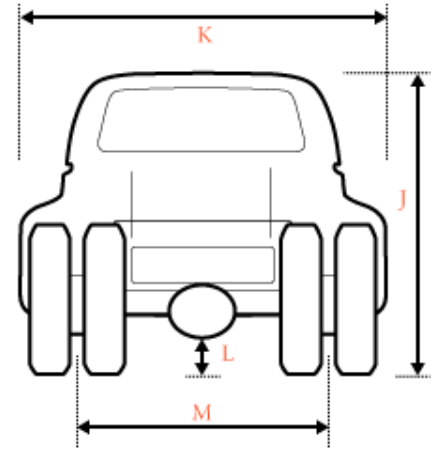
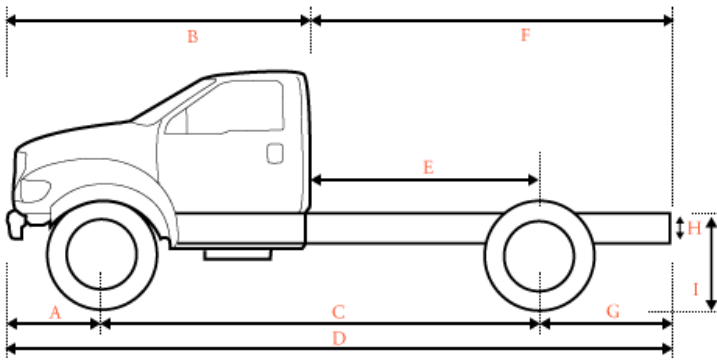

### Dimensions

A	Front of Bumper to Front Axle	39.00 in.
B	Front Bumper to Back of Cab (BBC)	113.00 in.
C	Wheelbase (WB)	158.00 in.
D	Overall Length (OAL)	246.00 in.
E	Back of Cab to Rear Axle (CA)	84.00 in.
F	Back of Cab to End of Frame	133.00 in.
G	Rear Axle to End of Frame (AF)	49.00 in.
H	Frame Section Height	10.10 in.
I	Rear Frame Height Unloaded	38.00 in.
I	Rear Frame Height Loaded	36.50 in.
J	Cab Height	95.20 in.
K	Body Width	96.70 in.
L	Maximum Ground Clearance	N/A
L	Minimum Ground Clearance	N/A
M	Front Tread	83.80 in.
M	Rear Tread	72.60 in.

Prices and content availability as shown are subject to change and should be treated as estimates only. Actual base vehicle, package and option pricing may vary from this estimate because of special local pricing, availability or pricing adjustments not reflected in the dealer's computer system. See salesperson for the most current information.

**Prepared for:**

ALL ROADS TRUCKS

Prepared by: Chris Crocker

03/20/2026



Norris Ford | 901 Merritt Blvd Baltimore Maryland | 212221491

---

**2027 F-750 Diesel Regular Cab Base (F7D)**

Price Level: 715 | Quote ID: 10DMP750GA

---

## Vehicle Dimension and Performance Summary (cont'd)

### Body Specs

Truck body style: .....	Dump
Cab to body gap: .....	3.00 in.
Body length: .....	10.00 ft
Body tare weight: .....	4,000 lbs
Body width: .....	96 in.
Body height from ground: .....	114 in.
Body Centre gravity (from front): .....	60.00 in.

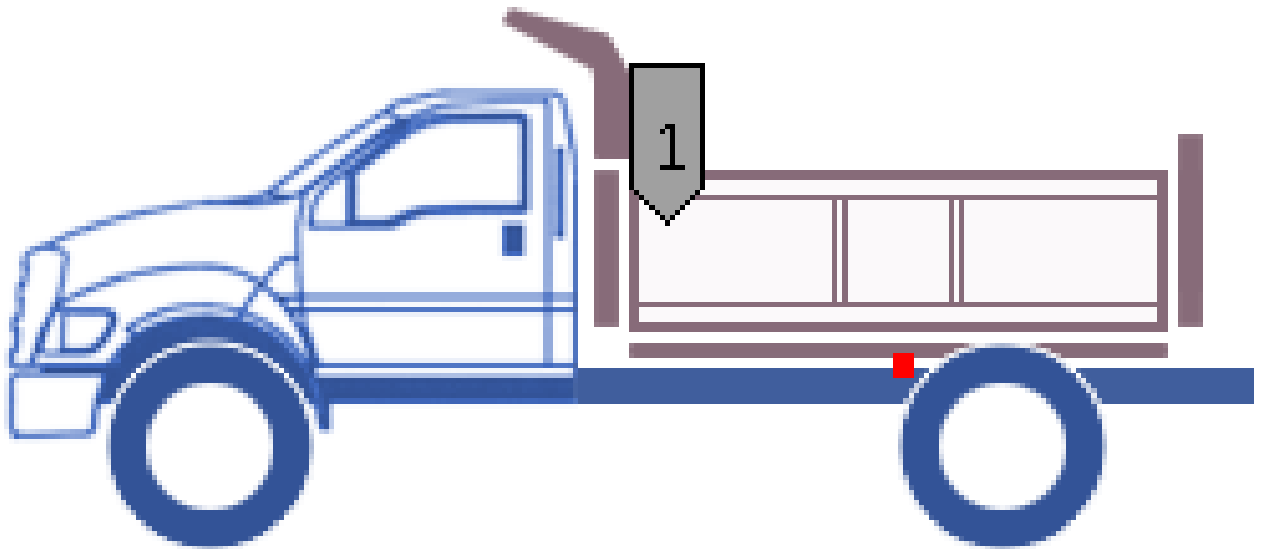

---

Prices and content availability as shown are subject to change and should be treated as estimates only. Actual base vehicle, package and option pricing may vary from this estimate because of special local pricing, availability or pricing adjustments not reflected in the dealer's computer system. See salesperson for the most current information.

**Prepared for:**

ALL ROADS TRUCKS

Prepared by: Chris Crocker

03/20/2026



Norris Ford | 901 Merritt Blvd Baltimore Maryland | 212221491

**2027 F-750 Diesel Regular Cab Base (F7D)**

Price Level: 715 | Quote ID: 10DMP750GA

**Vehicle Dimension and Performance Summary (cont'd)**

*Weight*

**Licensing**

GVWR does not exceed 26,000 lbs and may not require a Commercial Driver's License (CDL). Contact your local state commercial driver licensing office for specifics on what your state requires.

<b>GVW</b>	<b>Front Axle</b>	<b>Rear Axle</b>	<b>Totals</b>
Chassis .....	6,268 lbs	3,701 lbs	9,969 lbs
Body .....	532 lbs	3,468 lbs	4,000 lbs
Occupants Weight .....	200 lbs	100 lbs	300 lbs
1 Max Payload - (Max Payload) .....	5,000 lbs	13,731 lbs	18,731 lbs
<b>TOTAL</b> .....	<b>12,000 lbs</b>	<b>21,000 lbs</b>	<b>33,000 lbs</b>

<b>Ratings</b>	<b>Front Axle</b>	<b>Rear Axle</b>	<b>GVWR</b>
<b>GAWR</b> .....	<b>12,000 lbs</b>	<b>21,000 lbs</b>	<b>25,999 lbs</b>
Wheels/Tires .....	13,220 lbs	24,040 lbs	
Suspension .....	12,000 lbs	21,000 lbs	
Axle .....	12,000 lbs	21,000 lbs	
Legal Axle Limit .....	0 lbs	0 lbs	

**Front And Rear GAWR Total Will Exceed Overall GVWR**

Prices and content availability as shown are subject to change and should be treated as estimates only. Actual base vehicle, package and option pricing may vary from this estimate because of special local pricing, availability or pricing adjustments not reflected in the dealer's computer system. See salesperson for the most current information.

**Prepared for:**

ALL ROADS TRUCKS

Prepared by: Chris Crocker

03/20/2026



Norris Ford | 901 Merritt Blvd Baltimore Maryland | 212221491

**2027 F-750 Diesel Regular Cab Base (F7D)**

Price Level: 715 | Quote ID: 10DMP750GA

## Vehicle Dimension and Performance Summary (cont'd)

### Start, Grade and Speed

#### Shift Indicator

Vehicle equipped **without** Park Pawl. Shift indicator will display **RNDM**.

Start	Ratio	Desired	Calculated
Start grade capability in 1st gear	4.62	15.00 %	40.09 %
Start grade capability in reverse	4.70	15.00 %	40.78 %
Grade	Ratio	Desired	Calculated
Maximum grade in 8th gear	0.85	3.00 %	7.50 %
Maximum grade in 9th gear	0.69	3.00 %	6.06 %
Maximum grade in 10th gear	0.63	3.00 %	5.57 %
Speed		Desired	Calculated
Top Speed (level grade)		75 mph	99 mph
<i>To meet your requirement you need a maximum axle ratio of 8.15</i>			
Top Speed on 3% grade		55 mph	
<i>To meet your requirement you need a maximum of 166 hp</i>			
Cruise Speed		60 mph	71 mph
Engine RPM at desired cruise speed			1,938 rpm

### Variables in Use

#### Start

Rear axle ratio:	6.17	Clutch engagement torque:	400 ft.lbs.
Tire size:	11R22.5 (497 rev/mile)	Torque conversion ratio:	1.97
Gross Vehicle Weight (GVW):	25,999 lbs		

#### Grade

Rear axle ratio:	6.17	Gross Vehicle Weight (GVW):	25,999 lbs
Tire size:	11R22.5 (497 rev/mile)	Peak engine torque:	800 ft.lbs.

#### Speed

Engine Power:	270 hp @ 2,400 rpm	Worst road surface:	Typical Highway
Governed RPM:	3,200 rpm	Final Drive Ratio:	0.63
Frontal Area:	57.89 ft <sup>2</sup>	Drag Coefficient:	0.80
Cruising RPM:	2,300 rpm		

Prices and content availability as shown are subject to change and should be treated as estimates only. Actual base vehicle, package and option pricing may vary from this estimate because of special local pricing, availability or pricing adjustments not reflected in the dealer's computer system. See salesperson for the most current information.

**Prepared for:**

ALL ROADS TRUCKS

Prepared by: Chris Crocker

03/20/2026



Norris Ford | 901 Merritt Blvd Baltimore Maryland | 212221491

---

**2027 F-750 Diesel Regular Cab Base (F7D)**

Price Level: 715 | Quote ID: 10DMP750GA

---

## Vehicle Dimension and Performance Summary (cont'd)

### *Turning Radius*

Turning radius to curb: ..... 21.92 ft

Turning radius to bumper: ..... 23.49 ft

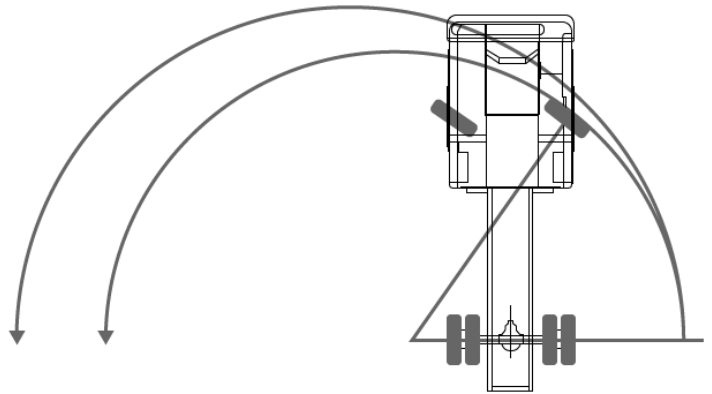

---

Prices and content availability as shown are subject to change and should be treated as estimates only. Actual base vehicle, package and option pricing may vary from this estimate because of special local pricing, availability or pricing adjustments not reflected in the dealer's computer system. See salesperson for the most current information.

**Prepared for:**

ALL ROADS TRUCKS

Prepared by: Chris Crocker

03/20/2026



Norris Ford | 901 Merritt Blvd Baltimore Maryland | 212221491

**2027 F-750 Diesel Regular Cab Base (F7D)**

Price Level: 715 | Quote ID: 10DMP750GA

**As Configured Vehicle**

Code	Description	MSRP
<b>Base Vehicle</b>		
F7D	Base Vehicle Price (F7D)	\$81,195.00
<b>Engines</b>		
99C	6.7L Power Stroke V8 Turbo Diesel - 270 HP @ 2400 RPM  Torque: 800 ft.lbs. @ 1500 rpm. <i>800 lb.-ft. torque @ 1500 RPM.</i>	STD
425	50-State Emissions	N/C
<b>Transmissions</b>		
44D	Ford TorqShift HD 10-Speed Automatic - with PTO Provision  <i>Includes tow/haul.</i>	STD
<b>Front Wheels &amp; Tires</b>		
643	Wheels, Front 22.5" x 8.25" White Powder Coated Steel, 10-Hole  <i>(285.75MM BC) hub piloted, flanged nut, metric mount, 8.25 DC rims; with steel hubs.</i>	STD
T2A	Tires, Front Two 11R22.5H Goodyear Fuel Max RSA (497 rev/mile)	STD
<b>Rear Wheels &amp; Tires</b>		
663	Wheels, Rear 22.5" x 8.25" White Powder Coated Steel, 10-Hole  <i>(285.75MM BC) hub piloted, flanged nut, metric mount, 8.25 DC rims; with steel hubs.</i>	STD
R2A	Tires, Rear Four 11R22.5H Goodyear Fuel Max RSA (497 rev/mile)	STD
<b>Brakes</b>		
67H	Hydraulic Brake System - Bosch HydroMax w/Traction Control  <i>Full power with automatic adjustment, 4-channel ABS antilock brake system. Includes 12" x 3" (Bosch) DSSA type rear axle mounted parking brake, Orscheln lever control, right of driver and hand operated park brake lever.</i>	STD

Prices and content availability as shown are subject to change and should be treated as estimates only. Actual base vehicle, package and option pricing may vary from this estimate because of special local pricing, availability or pricing adjustments not reflected in the dealer's computer system. See salesperson for the most current information.

**Prepared for:**

ALL ROADS TRUCKS

Prepared by: Chris Crocker

03/20/2026



Norris Ford | 901 Merritt Blvd Baltimore Maryland | 212221491

**2027 F-750 Diesel Regular Cab Base (F7D)**

Price Level: 715 | Quote ID: 10DMP750GA

**As Configured Vehicle (cont'd)**

Code	Description	MSRP
152	Trailer Connection Socket - 7-Way, Wired for Turn Signals Combined with Stop  <i>Mounted at rear of frame, for combined trailer stop, tail, turn, marker light circuits. Includes electric trailer brake accommodation package with cab connections for mounting customer installed electric brake unit.</i>	\$100.00

**Front Axle and Suspension**

43P	12,000 lb. Cap. Non-Driving - Dana E-1202I - I-Beam Type	\$525.00
61D	Taper-Leaf Springs, Parabolic - 12,000 lb. Cap  <i>2-leaf, 62" x 3.15". Also includes, standard duty, dual, double acting shock absorbers.</i>	\$305.00

**Rear Axle and Suspension**

475	21,000 lb. Single Reduction - Open - Dana / Spicer 21060S  <i>NOTE: When specifying an axle ratio, check performance guidelines for startability and gradeability.</i>	STD
68P	Multi-Leaf Springs - 21,000 lb. Cap  <i>For 19,000 lb. and 21,000 lb. rear axles. Includes 4,500 lb auxiliary rubber spring.</i>	STD
X6B	6.17 Axle Ratio	N/C

**Wheelbase**

158WB	158" Wheelbase/84" CA/49" AF/246" OAL	STD
-------	--	-----

**Frame**

536	Single Channel - Straight 'C' 14.18 SM, 120,000 PSI  <i>1,701,600 RBM. Heat treated alloy steel; 10.125" x 3.580" x 0.312" (257.2mm x 90.9mm x 8.0mm).</i>	\$365.00
18D	Special Rating GVWR - Limited to 25,999 lb. GVWR  Only available to GAWR combinations that EXCEED 26,000 lbs.	\$120.00

**Exhaust**

91G	Under Cab, Right Side Outlet, Switchback-Style	STD
-----	---	-----

Prices and content availability as shown are subject to change and should be treated as estimates only. Actual base vehicle, package and option pricing may vary from this estimate because of special local pricing, availability or pricing adjustments not reflected in the dealer's computer system. See salesperson for the most current information.

**Prepared for:**

ALL ROADS TRUCKS

Prepared by: Chris Crocker

03/20/2026



Norris Ford | 901 Merritt Blvd Baltimore Maryland | 212221491

**2027 F-750 Diesel Regular Cab Base (F7D)**

Price Level: 715 | Quote ID: 10DMP750GA

**As Configured Vehicle (cont'd)**

Code	Description	MSRP
------	-------------	------

*Single, horizontal muffler, right side, under cab, outside of frame rail with rear discharge.***Fuel Tanks**

65B	Fuel Tank - LH 50 Gallon Rectangular - Aluminum	STD
-----	--	-----

**Electrical / Alternator / Battery**

STDALT	Extra Heavy Duty Alternator - 12-Volt, 195 Amp	Included
STDBAT	Battery - Two 750 CCA, 1500 Total, Includes Steel Battery Box <i>12Volt, Motorcraft.</i>	STD
17M	Back-Up Alarm - Electric, 102 dBA	\$110.00
962	Daytime Running Lamps (Not Configurable)	\$25.00
16V	Voltmeter <i>Available in message center.</i>	\$100.00
61A	Embedded Modem Delete	-\$75.00

This option **MUST** be added to each order for the duration of the model year.*This will be a forced option on all orders and builds from start of production.***Seats**

88A	30/0/30 Fixed Driver & Fixed Passenger w/Consolette - Vinyl	STD
-----	--	-----

**Cab Interior**

600A	Preferred Equipment Package 600A <i>Includes:</i> - Bumper, Front - Black, Full Width - Wheel Seals, Front - Oil lubricated, SKF ScotSeal PlusXL Seals - Wheel Seals, Rear - Oil lubricated, SKF ScotSeal PlusXL Seals - Manual Regen Initiation - Driver Interface in Message Center - Engine Exhaust Brake - Extra Heavy Duty Alternator - 12-Volt, 195 Amp - Painted Grille - Plastic - Lights - Roof Marker/Clearance - Amber Lenses, 5 Lights - Tow Hooks, Front (2) - Frame-Mounted, Painted Black - Four Body Builder Switches - Mounted in Center Instrument Panel <i>With connector access located in engine compartment. Amperages vary by switch: 10, 15, 25, 25.</i> - Floor Covering - Black Vinyl	N/C
------	--	-----

Prices and content availability as shown are subject to change and should be treated as estimates only. Actual base vehicle, package and option pricing may vary from this estimate because of special local pricing, availability or pricing adjustments not reflected in the dealer's computer system. See salesperson for the most current information.

**Prepared for:**

ALL ROADS TRUCKS

Prepared by: Chris Crocker

03/20/2026



Norris Ford | 901 Merritt Blvd Baltimore Maryland | 212221491

**2027 F-750 Diesel Regular Cab Base (F7D)**

Price Level: 715 | Quote ID: 10DMP750GA

**As Configured Vehicle (cont'd)**

Code	Description	MSRP
	<ul style="list-style-type: none"> <li>- Intelligent Oil Life Monitor</li> <li>- Steering Column - Tilt / Telescoping</li> <li>- Steering Wheel - Black PVC w/Integral Cruise Control Switches, includes Audio Controls</li> <li>- Body Builder Wiring - At Back of Cab, Combined</li> </ul> <p><i>Includes sealed connectors for 2 ground circuits, with combined left/stop, combined right/stop, park lamps, back up lamps. Also includes 2 additional pass through wires to cab.</i></p>	
90P	<b>Power Equipment Group - (Included in (90A) Appearance Group)</b> <i>Includes power front side windows, power door locks and door trim panel.</i>	\$580.00
	<i>Includes:</i> <ul style="list-style-type: none"> <li>- Remote Keyless Entry</li> </ul>	
588	<b>Radio: AM/FM Stereo w/2 Speakers, USB input, Clock Display and Bluetooth</b>	STD
<b>Cab Exterior</b>		
54C	<b>Mirrors, Dual - Heated Rectangular, XL2020 - 102" Width</b> <i>Integral spot mirror, sail type, manual fold, solid black finish.</i>	\$30.00
<b>Miscellaneous</b>		
PAINT	<b>Paint Type - Environmentally Friendly, "3 - Wet System"</b>	STD
<b>Exterior Color</b>		
YZ_01	Oxford White	N/C
<b>Interior Color</b>		
E_01	Gray	N/C
<b>Upfit Options</b>		
10FTOXMAV	<b>OX BODY 10FT MAVERICK DUMP - 36" SIDED - ELECTRIC TARP SYSTEM</b>	\$25,659.00
<b>SUBTOTAL</b>		<b>\$109,039.00</b>
<b>Fuel Charge (12)</b>		<b>\$0.00</b>
<b>Destination Charge</b>		<b>\$2,495.00</b>

Prices and content availability as shown are subject to change and should be treated as estimates only. Actual base vehicle, package and option pricing may vary from this estimate because of special local pricing, availability or pricing adjustments not reflected in the dealer's computer system. See salesperson for the most current information.

**Prepared for:**

ALL ROADS TRUCKS

Prepared by: Chris Crocker

03/20/2026



Norris Ford | 901 Merritt Blvd Baltimore Maryland | 212221491

---

**2027 F-750 Diesel Regular Cab Base (F7D)**

Price Level: 715 | Quote ID: 10DMP750GA

---

**As Configured Vehicle (cont'd)**

<b>Code</b>	<b>Description</b>	<b>MSRP</b>
TOTAL		\$111,534.00

---

Prices and content availability as shown are subject to change and should be treated as estimates only. Actual base vehicle, package and option pricing may vary from this estimate because of special local pricing, availability or pricing adjustments not reflected in the dealer's computer system. See salesperson for the most current information.



Ox Bodies | Crysteel | Duraclass | Rugby | J-Craft | Travis

PROUDLY MADE IN THE USA

719 Columbus Street East

Fayette AL. 35555

# Quote Response Form

3/18/2026 3:59:45 PM

Salesperson: Sherry Sanford

800-844-2519

**End User:** EFFINGHAM COUNTY, GA

**Route To:** 14913  
ALL ROADS KENWORTH LLC  
2909 SOUTH ANDREWS AVE  
FT LAUDERDALE FL 33316  
USA

**Ship To:** 11  
TP INVESTMENT GROUP - FORT PIERCE  
5690 ENVIRONMENT DRIVE  
FORT PIERCE, FL 34981

Quote	Revision	Ship Via	Terms
FAC17211	1	OX4 - DRIVE AWAY	Net 30 Days

Line	UM	Quantity	Item	Description	Unit Price	Extended Price
1	EA	1.00	2769271	MABMV87-1000-810YD-6382-56/36/44-BLK-T	\$ 22,966.31	\$ 22,966.31

Yardage 8/10

BASE OPTIONS:

Body Style: MAVERICK

Body ID: 87

Body Length: 10'

Hoist Model: 6382

Frame Style: TUBE w/CHANNEL X-MEM 12 C/L

Front Style: STRAIGHT

Rear Style: STRAIGHT

Front Height: 56

Side Height Front: 36

Side Height Rear: 36

Rear Height: 44

Side Material: SHEET-10GA-A36

Front Material: SHEET-10GA-A36

Tailgate Material: SHEET-7GA-A36

Floor Material: SHEET-3/16-A36

Cabshield Style: STANDARD

Cabshield Projection: 24

Cabshield Width: 87

Tarp Style: MOUNTAIN

Tailgate Type: STANDARD

Tailgate Bracing Style: 1 HORIZONTAL

Side Top Rail Style: 4x4x.120 (Standard)

Lineposts: YES

Dump Apron: HEAVY DUTY

Dump Apron Size: 8

Side Light Cutouts: LOWER - FRONT

Metro Light Quantity: 1

Board Holder Height: 8

CUSTOM OPTIONS:

Metal / Wood Boards: 8 INCH WOOD BOARDS (UP TO 17FT)

PAINT OPTIONS:

Paint Color: BLACK

INSTALL OPTIONS:

Chassis: OTHER  
Rear Hinge: REMOVABLE PIN  
Hydraulic Cylinder: 6382 (STD)  
Hydraulic Reservoir: NESTLED RECTANGULAR  
Power Take Off: FORD TS 10 SPEED DIESEL - INSTALL PTO  
Hydraulic Pump: PUMP - CGP16-85A-2N1  
In-Cab Controls: OX CONTROL TOWER w/ AIR LEVER  
Mud Flaps: 30 INCH OX MUD FLAPS  
Gravel Guards: STEEL-NO FLAPS-MV/CHIS  
Reversing Alarm: YES  
Body Prop: ONE  
Tailgate Closing Operation: TAILGATE KIT AIR  
Exhaust Turnout: 5 INCH  
Decals: STANDARD OX LOGOS  
Cab Shield Lights: LTS KIT C/S 2 C/M  
Side Lights: LTS KIT SIDE LWR FRT C/M - MAVR UP TO 16FT  
Rear Lights: LTS KIT REAR 1SET MET

2 EA 1.00 2262589 TARP ELEC-MOUNTAIN-10-16FT-MSH-N/FL-INST

PTO Maintenance:

Per OEM manufacturer guidelines the following recommendations should be followed. Failure to follow OEM guidelines can result in non warrantable failure.

Within the first week of use, recheck the installation of the PTO. Check for leaks and loose mounting hardware (studs, cap screws, nuts). Recheck the cable or lever connections for proper adjustment and tighten any loose connections. At regular maintenance intervals, check adjustments and lubricate moving parts, tighten and repair the connections, mounting hardware, cable or lever linkage. Refer to OEM owners manual for regular maintenance intervals.

**\*\*By signing below I acknowledge that I have reviewed the specs above and confirmed they are correct. I understand that once my order is placed and sent into production that I will not be able to make changes to the order.**

I assume full ownership of the body once production begins.

Due to the current volatility of the metals market, effective February 23, 2021 quotes will be valid for 7 days.

X \_\_\_\_\_  
TRUCK YEAR/MAKE/MODEL \_\_\_\_\_ CLEAR CT: \_\_\_\_\_  
VIN \_\_\_\_\_ TRANS \_\_\_\_\_  
ETA \_\_\_\_\_ DUMP BODY COLOR \_\_\_\_\_

**\*\*Pto switch in dash is recommended for all automatic or automated transmissions.\*\***

**\*\*Tractor valve must be in cab for glads to be plumbed \*\***

**\*\*Verify ship to address on quote.\*\***

**Sales tax is calculated at the time an order is placed, not when a quote is issued. Quotes serve only as estimates, and the final tax amount is determined based on the regulations in effect at the moment the order is processed.**

<b>Gross Sales:</b>	\$	22,966.31
<b>Order Disc</b>	\$	-
<b>Sale Amount:</b>	\$	22,966.31
<b>Freight:</b>	\$	2,692.00
<b>Sales Tax:</b>	\$	-
<b>FET Charges:</b>	\$	-
<b>Total Amount:</b>	\$	25,658.31

**Prepared for:**

ALL ROADS TRUCKS  
Prepared by: Chris Crocker  
03/20/2026



Norris Ford | 901 Merritt Blvd Baltimore Maryland | 212221491

**2027 F-750 Diesel Regular Cab Base (F7D)**

Price Level: 715 | Quote ID: 10DMP750GA

**Pricing Summary - Single Vehicle**

	<b>MSRP</b>
<i>Vehicle Pricing</i>	
Base Vehicle Price	\$81,195.00
Options	\$2,185.00
Colors	\$0.00
Upfitting	\$25,659.00
Fleet Discount	\$0.00
Fuel Charge (12)	\$0.00
Destination Charge	\$2,495.00
<b>Subtotal</b>	<b>\$111,534.00</b>
<i>Discount Adjustments</i>	
Discount Adjustments	-\$5,219.44
<b>Total</b>	<b>\$106,314.56</b>

\_\_\_\_\_  
Customer Signature

\_\_\_\_\_  
Acceptance Date

**OPTIONAL EXTENDED WARRANTY NOT INCLUDED IN ABOVE PRICE:  
5YR 150,000 MILE FORD PREMIUM CARE \$3895**

**-EXTENDS BASIC (NON-WEAR COMPONENTS), POWERTRAIN, AND EXHAUST  
AFTERTREATMENT COMPONENTS FOR 5YR/150K MILES**

Prices and content availability as shown are subject to change and should be treated as estimates only. Actual base vehicle, package and option pricing may vary from this estimate because of special local pricing, availability or pricing adjustments not reflected in the dealer's computer system. See salesperson for the most current information.