

PURCHASE ORDER

Effingham County Board of Commissioners

804 S LAUREL STREET
SPRINGFIELD, GA 31329
Phone: 912-754-2159
Fax: 912-754-8413

DATE:
P.O. #

9/5/2023
23-REQ-039

VENDOR

MWI Pumps
33 NW 2ns Street
Deerfield Beach, FL 33441

ATTN : Kelby Morgan
(772)321-3425 / kelbym@mwipumps.com

SHIP TO

Effingham County Board of Commissioners
804 S.Laurel Street
Springfield, GA 31329
ATTN : Alison Bruton
912-754-2159

REQUISITIONER	SHIP VIA	F.O.B.	SHIPPING TERMS
ECBOC			

ITEM #	DESCRIPTION	QTY	UNIT PRICE	TOTAL
	Sewer Bypass Pump	1	\$94,678.00	\$ 94,678.00
	*Price includes hoses & accessories			
	*Lead Time: 12-14 weeks after receipt of PO/NTP			
	*Warranty: 1 year			
	*Specs provided as separate attachment			

SUBTOTAL	\$ 94,678.00
TAX RATE	\$ -
TAX	\$ -
S & H	\$ -
OTHER	\$ -
TOTAL	\$ 94,678.00

OTHER COMMENTS OR SPECIAL INSTRUCTIONS

ECBOC is a tax exempt entity. Tax ID# is 58-6000821

MWI Pumps agrees to furnish one (1) Sewer Bypass Pump as described in 23-REQ-039. The County references the terms, conditions and specifications contained in 23-REQ-039.

MWI PUMPS - SIGNATURE

TITLE

MWI PUMPS - PRINT NAME

DATE

AUTHORIZED BY - SIGNATURE

CHAIRMAN

AUTHORIZED BY - TITLE

WESLEY CORBITT

AUTHORIZED BY - PRINT NAME

AUTHORIZED DATE



Established 1926

Manufacturers

Attachment A - PO 23-REQ-039

Moving Water Worldwide - Reliably and Efficiently

August 3, 2023

To: Effingham County

Re: Sewer Bypass Pump

Thank you for the opportunity to submit for proposal our MWI CT008 diesel powered engine, sound attenuated, trailer mounted self-priming sewer bypass pump. MWI is an American manufacturer of construction, industrial, mining, and custom engineered pumps. Family owned and Florida based, in business since 1926. The following equipment is included in our bid proposal:

- One (1) MWI Primerite model CT008 automatic dry self-priming sewer bypass pump with Deutz TCD 3.6 Tier 4 Diesel engine rated 123hp @ 1800rpm. Enclosed by a sound attenuating enclosure, wholly mounted on a DOT approved trailer with electric brakes and wiring harness.
- One (1) set float assembly, start/stop, 50' N/O floats
- Six (6)- 8" x 10' composite hoses with quick connects
- One (1)- 8" Bauer strainer
- One (1)- 90 Degree elbow

Total Price: \$94,678 plus applicable sales tax

Our bid also includes:

- MWI's one (1) year warranty
- Freight to Effingham County, GA.

Specifically not included:

- Unloading or installation

If bid is accepted, freight prepaid to job site within Effingham county Georgia, with contractor to unload. Terms are Net 30 days after delivery. Delivery will be approximately 12-14 weeks after receipt of purchase order/notice to proceed.

We appreciate the opportunity to quote our equipment and look forward to your favorable consideration.

Yours Truly,

MWI CORPORATION

Kelby Morgan

kelbym@mwipumps.com

MWI Pumps

33 N.W. 2nd Street Deerfield Beach, Florida 33441 | p. (954) 426-1500 | f. (954) 426-1582 | www.mwipumps.com

PRIMERITE™ CT008

8" X 8" AUTOMATIC DRY SELF-PRIMING TRASH PUMP

Attachment A - PO 23-REQ-039



APPLICATIONS

Construction
Dewatering

Sewage Bypass

Flood Drainage

Mining/Quarries

Municipal

General Industrial

The Primerite™ is the perfect pump for contractors, pump rental companies, mining operators and general industrial or municipal use. The pump's oil-filled bearing box and a mechanical seal in an oil bath enable it to run dry all day long for up to 24 hours, making it the right choice for handling inconsistent flows found in sewage bypass pumping and job site dewatering. This pump is completely self contained in either skid or trailer configurations with integral lifting bail, tie downs and fuel tank.

FEATURES

- Primes and reprimed automatically
- Solids handling up to 3.125"
- Engine driven compressor
- Vacuum and discharge pressure gauge
- Lockable fuel cap
- Forklift slots (skid models)
- Torsion bar axle
- Integral 94 fuel tank with gauge
- Skid or optional trailer-mounted
- DOT light kit available
- Hydraulic surge brakes standard, electric brakes available
- Front and rear stabilizing jacks
- 3" Lunette ring for pintle hitch – Other options available
- Lifting bail
- Volute drain
- Heavy-duty truck tie downs
- Engines – Caterpillar, Perkins, John Deere and Deutz available
- Flexible flywheel coupling
- 8" ANSI Pattern flanges – Suction and discharge
- Optional float activated, auto start/stop controls
- Manufactured in the USA

QUICK SPECIFICATIONS

Suction connection	8" 150# ANSI B16.5
Delivery connection	8" 150# ANSI B16.5
Max capacity	3750 GPM
Max solids handling	3.125"
Max impeller diameter	12.2"
Max head (TDH)	140'
Max operating speed	1900 rpm
Max suction lift	24'
Dimensions	65 x 96 x 148"
Sound levels w/ enclosure	67 dBA at 7M / 23'
Max fuel consumption	At 75 HP; up to 24 hr run time



PRIMERITE™ CT008

PERFORMANCE CURVE

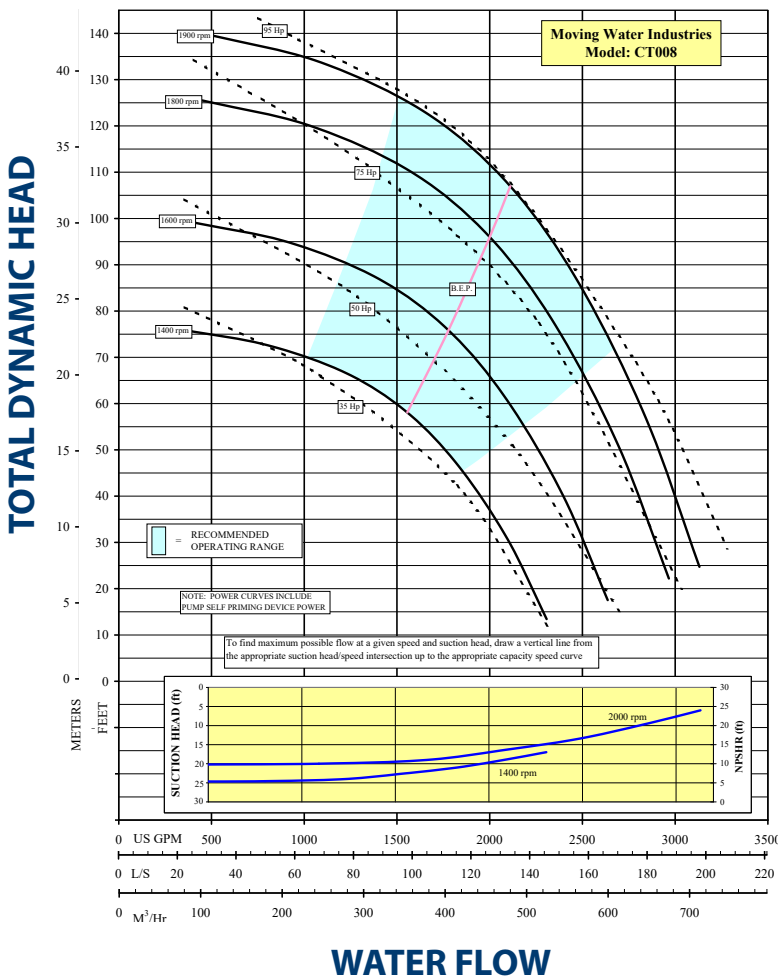

DIMENSIONS

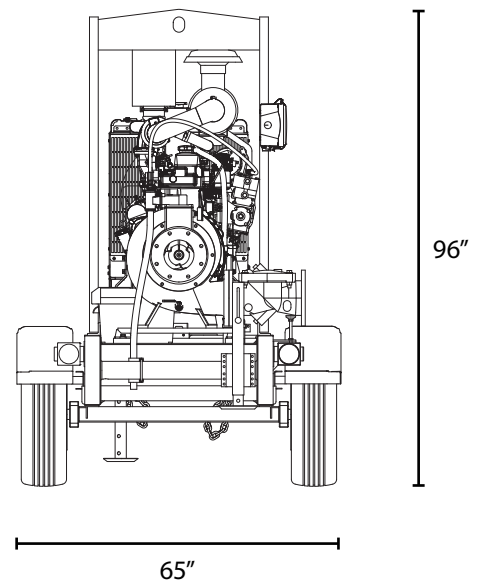
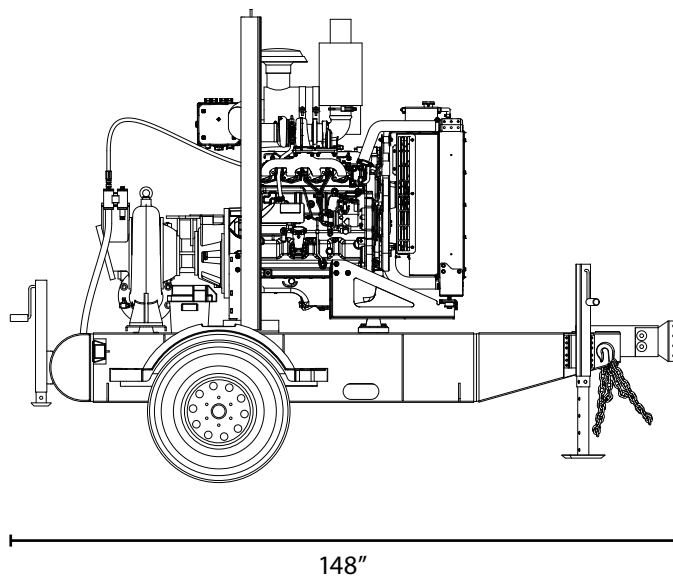

MATERIALS & SPECIFICATIONS

Standard engine	Deutz TCD 3.6 Tier 4 Final Diesel
Max HP	99 HP
Fuel capacity	94 Gal
Drive type	Flywheel direct drive flexible element
Impeller	CA-40 Corrosion resistant iron/chromium alloy
Volute	Ductile cast iron ASTM A536 grade 70-50-05
Pump shaft	1045 Steel; Stainless steel option
Compressor	Engine-driven, oil lubricated and water cooled
Priming assembly	304 Stainless steel venturi
Control panel	Tach and hour meter, including shutdowns for low oil pressure, high coolant temperature, Plug-N-Play and float-ready
Discharge non-return valve	Val-matic swing flex check valve ASTM A536 grade 65-45-12
Mechanical seal	Stainless steel with silicon carbide faces; Buna elastomers
Weight of trailer mounted unit	3900 lbs (dry)

MWI Pumps Headquarters

33 NW 2nd St | Deerfield Beach, FL 33441

Copyright © 2019 MWI Pumps | All rights reserved. Subject to change without notice.

Inquiries: 954-426-1500 | Fax: 954-426-8938 | Email: info@mwipumps.com | mwipumps.com