

# STAR Series LED Beacon

"The only beacon you'll need"

## Medium Intensity Obstruction Light:

**LONESTAR** - FAA-L864/865 Dual Red/ White w/IR

**DAYSTAR** - FAA-L865 White w/IR

**NIGHTSTAR** - FAA-L864 Red w/IR

# TWR



## Overview

The STAR Series are medium intensity flashing LED obstruction beacons designed for reliable day and night time marking of structures. This light integrates a robust mechanical structure and modular electronics with the most advanced LED optics and controls creating the cleanest installation by only requiring a single controller and cable, making this the easiest lighting system to maintain and operate in the industry.

The modular electronics allow for field repairs. This medium intensity flashing beacon is capable of accepting AC or DC input power and offers the first ever optional power supply available in the beacon or in the controller.

## Standards and Certifications

- FAA AC70/7460-1M
- ICAO Annex 14 Volume 2
- CAR 621
- DGAC

## General Specifications

Operating Voltage	120-240 VAC (Optional: 24-48 VDC)
Frequency	50/60 Hz
Beacon Dimensions LxWxH	18.5 x 18.5 x 8.5 in. (469.9 x 469.9 x 215.9 mm.)
Beacon Weight	36 lbs. (16.3 kg.)
Controller Dimensions LxWxH	18.5 x 18.5 x 8.5 in. (469.9 x 469.9 x 215.9 mm.)
Controller Weight	25 lbs. (11.4 kg.)
Protection Rating	NEMA 4 IP66
Operating Temperature Range	-67°F to +130°F (-55°C to +55°C)
Power Consumption	Night >15 watts Day >35 watts

## Key Features

- Five-year warranty
- Electronics available in light fixture or at ground level
- Modular design, easy access to all components
- Simpler cable installation
- Low power consumption
- 15-20 years of operation
- Infra-red (IR) included
- Transient protection per IEEE C62.41-1991
- Optional GPS synchronization
- Option DC power supply

## Performance

- Effective intensity 20,000cd white, 2,000cd red and 246mW/sr IR Radiant
- Horizontal beam coverage 360 degrees
- Vertical beam coverage 3 degree
- Form "C" failure alarm
- LED Temp Comp



# STAR Series LED Beacon

"The only beacon you'll need"

## Medium Intensity Obstruction Light:

**LONESTAR** - FAA-L864/865 Dual Red/ White w/IR

**DAYSTAR** - FAA-L865 White

**REDSTAR** - FAA-864 Red w/IR

# TWR

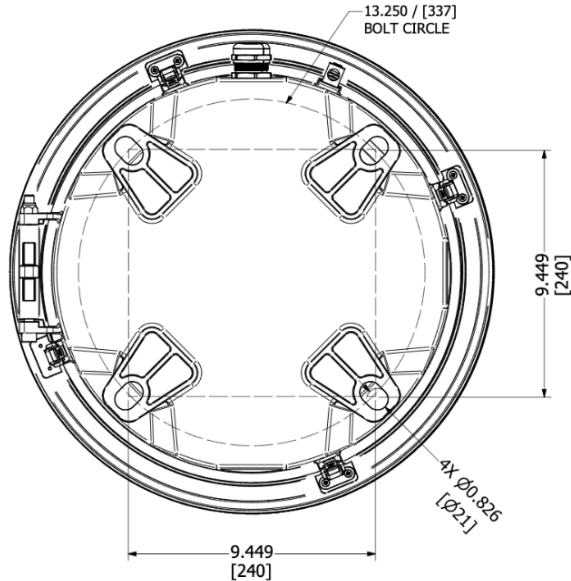

## Optional Monitoring Features

### Monitoring Features

- 10 Additional alarm inputs
- Cabinet access alarm
- SNMP programming Get/Sets
- SNMP traps for alarms
- System operation event history record
- Manual control override of connected lights
- Cabinet temperature
- Backup battery discharge protection
- Real-time clock / Eprom for configuration
- 0-30 VDC analog monitoring ports

### Monitoring Options

- GPRS/CDMA wireless modem
- Ethernet TCP/IP modem

### Monitoring Services

- FCC QLI Compliant
- TWR Web Portal provides online access to review your monitored sites
- Automatic email notification of NOTAM status changes
- TWR NOC full reporting monitoring service
- HIMS (Hark Independent Monitoring Service) (Client-monitored)

## Flashes Per Minute

Product	Night	Day
L864-IR (Red)	30	-
L865-IR (White)	40	40
L864-IR/L865 (Red/White)	30	40

## Power Consumption @ 20° C

Product	Night	Day
L864-IR (Red)	12.5 W	1 W
L865-IR (White)	7.5 W	32 W
L864-IR/L865 (Red/White)	12.5 W	32 W

