

PURCHASE ORDER

Effingham County Board of Commissioners

804 S LAUREL STREET
SPRINGFIELD, GA 31329
Phone: 912-754-2159
Fax: 912-754-8413

DATE: 8/15/2023
P.O. # 23-REQ-035

VENDOR

Hills Machinery
512 Bourne Ave.
Savannah, GA 31408

ATTN : Donnie Crosby
dcrosby@hillsmachinery.com

SHIP TO

Effingham County Board of Commissioners
804 S.Laurel Street
Springfield, GA 31329
ATTN : Alison Bruton
912-754-2159

REQUISITIONER	SHIP VIA	F.O.B.	SHIPPING TERMS
ECBOC			

ITEM #	DESCRIPTION	QTY	UNIT PRICE	TOTAL
	Mid-Size Wheel Loader	1	\$225,000.00	\$225,000.00
	Fork Attachment - Pipe Style	1	\$6,700.00	\$6,700.00
	4-in-1 Bucket	1	\$17,000.00	\$17,000.00

SUBTOTAL \$ 248,700.00
TAX RATE \$ -
TAX \$ -
S & H \$ -
OTHER \$ -
TOTAL \$ 248,700.00

OTHER COMMENTS OR SPECIAL INSTRUCTIONS
ECBOC is a tax exempt entity. Tax ID# is 58-6000821

Hills Machinery agrees to furnish one (1) Mid-Size Wheel Loader and attachments as described in 23-REQ-035. The County references the terms, conditions and specifications contained in 23-REQ-035.

Hills Machinery - SIGNATURE

TITLE

Hills Machinery - PRINT NAME

DATE

AUTHORIZED BY - SIGNATURE

CHAIRMAN

AUTHORIZED BY - TITLE

WESLEY CORBITT

AUTHORIZED BY - PRINT NAME

AUTHORIZED DATE

ZW-6 series

HITACHI

Reliable solutions

ZW180

Tier 4 Final
Certified

173 hp 129 kW
Engine Output, Max, Gross
(ISO 14396)

168 hp 125 kW
Engine Output, Max, Net
(ISO 9249)

3.4 yd³ 2.6 m³
Bucket capacity

32,100 lbs 14,560 kg
Operating weight



ZW180-6 NO COMPROMISE

The latest Hitachi wheel loaders have been developed specifically to meet the demands of the evolving North American construction industry. The ZW180-6 offers exceptional levels of performance without compromising on efficiency, thanks to low levels of fuel consumption.

The new model underlines Hitachi's reputation for high-quality engineering and durable products. The epitome of reliability, the ZW180-6 is also extremely versatile for a variety of industry solutions.



6. FIRST FOR RELIABILITY



8. DEDICATED TO DURABILITY



10. INCREDIBLE VERSATILITY



HITACHI



12. INDUSTRY-LEADING QUALITY



14. UNIQUE TECHNOLOGY

Image includes optional items. Please contact your local Hitachi Wheel Loader dealer for availability.

DEMAND PERFECTION

The ZW180-6 has been designed and built using market-leading technology in Japan. Developed to perfection, with an emphasis on the environment, operator comfort and safety, it responds to customer demands for exceptional productivity at the lowest possible cost of ownership.



Industry-leading safety
360° visibility from the cab.



Easy to operate

New multifunctional monitor shows information at a glance.



Smooth operation

Ride control minimizes machine pitching.



Superior comfort

Spacious cab with several storage compartments.

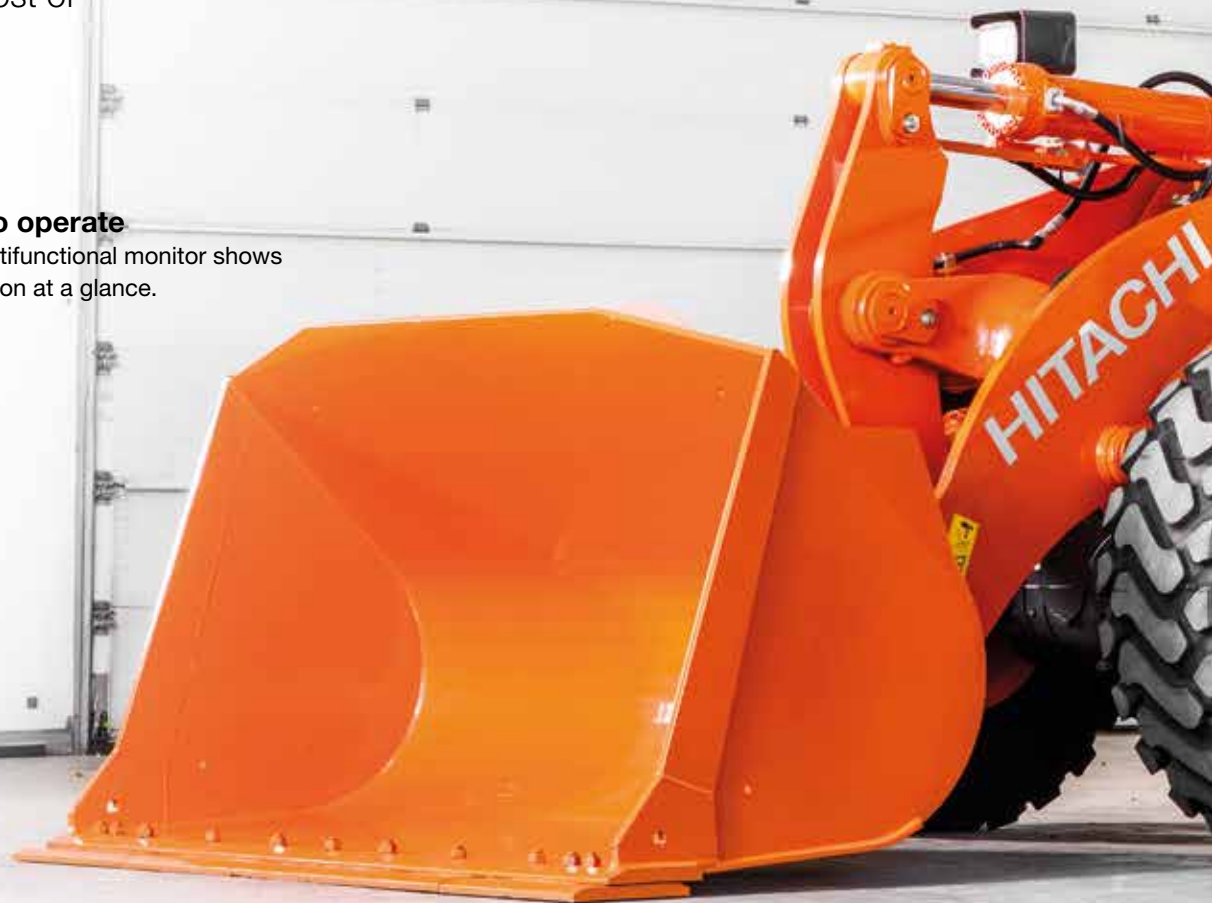



Powerful performance

Quick power switch increases engine output when required.



Enhanced design

Excellent rear view thanks to the curved engine hood.



Quieter performance

New materials in the cab absorb sound to reduce noise levels.



Enhanced fuel efficiency

New Tier 4 Final engine without DPF.



Low running costs

7% fuel saving in V-shaped loading (5% in load and carry operations).



Exceptional durability

The front lift arm has a thicker cross tube to provide more strength against torsion.



Convenient access

Easy-to-open wide engine covers.

FIRST FOR RELIABILITY

The reliability of the ZW180-6 Hitachi wheel loader ensures it operates at the highest levels of efficiency on a wide range of job sites. Designed with several easy maintenance features, it delivers an optimum performance with minimal downtime, helping to reduce running costs.

Minimal downtime

The ZW180-6 battery compartment can be accessed easily for maintenance and battery replacement. This results in minimal downtime and a high level of accessibility.

Quick access

The engine covers open full for convenient access. This helps to ensure routine maintenance is completed quickly to ensure a reliable performance.

Improved fuel efficiency

The ZW180-6 demonstrates greater fuel efficiency than the previous model during V-shape loading, and load and carry operations. This results in considerable savings for running costs.

Easy maintenance

For safer and easier maintenance, the battery disconnect switch is standard. This helps to avoid electrical accidents and retain battery energy during long-term storage.

Reduced cost

The new Tier 4 Final-compliant engine does not require a diesel particulate filter, which further reduces fuel consumption and maintenance costs.



Easy access to the engine compartment.



Easy access battery compartment



Fuel efficient Cummins engine, with NO DPF.



ZW180

HITACHI



Increased lift arm strength.



Standard clog resistant cooling cores.

Image includes optional items. Please contact your local Hitachi Wheel Loader dealer for availability.



i The final pre-delivery inspection procedure for each Hitachi wheel loader is typical of Hitachi's dedication to manufacturing products of unflinching quality in response to customer needs.



DEDICATED TO DURABILITY

Hitachi is dedicated to the design and engineering of robust construction machinery. In line with this, the new ZW180-6 wheel loader has been built with durable materials, strengthened components and added protection for key features to operate reliably in demanding conditions.



The optional belly guard provides added protection.

Added protection

The optional belly guard protects the machine powertrain and driveshaft from potential damage caused by materials on the ground.

Strengthened components

The lift arm strength of the ZW180-6 has been increased to meet customer demand.

Durable materials

High-quality radiators improve resistance to corrosion and enhance the overall durability of the ZW180-6 wheel loader.

Maximum uptime

Standard cooling cores are designed with wide spaced square-shaped fins, instead of triangular-shaped fins to resist clogging. This reduces cooling cores maintenance.

INCREDIBLE VERSATILITY

The ZW180-6 is suitable for working on a variety of job sites and wide range of applications thanks to its versatility. Whatever the task, it offers a smooth and efficient operation, increased productivity and greater fuel efficiency.

Efficient flexibility

The quick power switch increases engine output when more power is instantly required, or when driving uphill.

Enhanced rear visibility

The muffler and air intake have been repositioned and aligned to improve the rear-view visibility from the cab, enhancing safety on a variety of job sites.

High productivity

The simultaneous movement of the bucket and lift arm ensures a smooth digging operation. The Hitachi flow control system ensures smooth lift arm starts and stops.

Effective control

To ensure a smooth drive on all kinds of terrain, the ride control feature prevents unnecessary pitching via the movement of lift arm cylinders.



Rear visibility has been enhanced by design modifications.



The ride control feature ensures smooth travel performance.



The quick power switch increases power when required.



ZL180

HITACHI



Urea is injected into the exhaust gas to reduce emissions.



Ground level access for easy maintenance.

i Hitachi conducts user tests to assess the features of its wheel loaders. Results have revealed an unrivaled level of control.



INDUSTRY-LEADING QUALITY

Thanks to the use of high-quality components, the ZW180-6 meets the highest possible standards of performance, reliability, comfort and safety. Offering the best all-round visibility in its class, it is also one of the quietest wheel loaders available in the market.

Reduced emission

A selective catalytic reduction (SCR) system injects urea into exhaust gas to reduce nitrous oxide from emissions. This cutting-edge technology not only helps the environment, but also complies with Tier 4 Final emission regulations.

Easy access

The engine air filter has been relocated to the rear of the engine compartment, providing easier access at ground level for maintenance. The urea tank is also positioned for convenience.

Excellent visibility

The 360° panoramic view of the spacious cab creates a comfortable working environment, and helps to increase safety and productivity. The rear-view camera also contributes to excellent all-round visibility and safety on the job site.

Improved comfort

Sound insulation has been improved in the cab to significantly reduce noise levels and provide a quieter working environment for operators. The low-noise engine also results in a quieter performance, which makes it suitable for working in urban areas.



NO DPF SCR system reduces emissions.

UNIQUE TECHNOLOGY

Designed with a focus on the environment, operator comfort and safety, the ZW180-6 incorporates advanced technology developed by Hitachi in Japan. This technology is at the heart of Hitachi's success in enhancing the experience of its customers, and satisfying increasingly demanding industry requirements.

Reduced maintenance

A new Tier 4 Final certified engine contains a high-volume cooled exhaust gas recirculation (EGR) system, a common rail-type fuel injection system and a diesel oxidation catalyst (DOC), which are maintenance free.

Smaller environmental impact

The standard auto idle shutdown feature helps to prevent fuel waste, as well as reduce noise levels, exhaust emissions and CO₂ levels of the ZW180-6 wheel loader.

Optimum performance

Hitachi ZW-6 wheel loaders are fitted with a multifunctional LCD color monitor that shows useful information at a glance, such as fuel and urea levels, oil temperature and power mode. It ensures an optimum performance and easy maintenance. It also includes the display for the easy-to-use rear-view camera, which enhances visibility for a safe operation.

Remote monitoring

Global e-Service allows ZW180-6 owners to monitor their Hitachi machines remotely via Owner's Site (24/7 online access) and ConSite (an automatic monthly report). These help to maximize efficiency, minimize downtime and improve overall performance.

Improved performance

An auto power up function increases engine rpm as the ZW180-6 slows down when travelling uphill. Operational time is optimized by improved traveling performance.

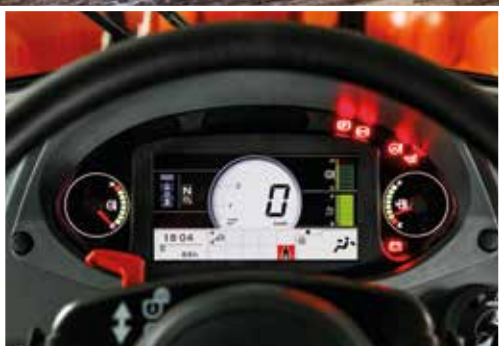

New LCD monitor shows the machine's status and settings.



Auto power up function improves uphill performance.



Reduced maintenance with the new Tier 4 Final-compliant engine.

REDUCING THE TOTAL COST OF OWNERSHIP

Hitachi has created the After Sales Solutions Program to ensure optimum efficiency, as well as minimal downtime, reduced running costs and high resale values.

Global e-Service

Hitachi has developed two remote monitoring systems as part of its Global e-Service online application. Owner's Site and ConSite are an integral part of the wheel loader, which sends operational data daily via GMS to www.globaleservice.com. This allows immediate access to the Owner's Site, and the vital information that is required for support on job sites.

Comparing the ratio of operating and non-operating hours helps to enhance efficiency. Effective management of maintenance programs helps to maximize availability. Running costs can

also be managed by analyzing the fuel consumption. The location and movements of each machine are clearly displayed for essential planning.

An automatic service report — ConSite — sends a monthly email summarizing the information from Global e-Service for each machine. This includes: daily working hours and fuel consumption data; statistics on the operating mode ratio, plus a comparison for fuel consumption/efficiency, and CO₂ emissions.

Technical support

Each Hitachi service technician receives full technical training from HCMA in the USA. These sessions provide access to the same technical knowledge available within the Hitachi quality assurance departments and design centers. Technicians combine this global expertise with the local language and culture of the customer to provide the highest level of after-sales support.



Global e-Service



Technical support



Hitachi Parts

Extended warranty and service contracts

Every new Hitachi ZW-6 model is covered by a full manufacturer's warranty. For extra protection—due to severe working conditions or to minimize equipment repair costs—Hitachi dealers offer a unique extended warranty called HELP (Hitachi Extended Life Program) and comprehensive service contracts. These can help to optimize the performance of each machine, reduce downtime and ensure higher resale values.

Parts

Hitachi offers a wide range, and high availability, of parts located in the new 400,000 sq. ft. Parts Depot centrally located just outside of Atlanta, Georgia.

- Hitachi Genuine Parts: allow machines to work longer, with lower running and maintenance costs.
- Hitachi Select Parts and Genuine Parts: are of proven quality and come with the manufacturer's warranty.

- Performance Parts: to cope with highly demanding conditions, they have been engineered for greater durability, better performance or longer life.
- Genuine Hitachi rebuilt components are available from HCMA's in-house rebuild center and are offered with a standard warranty.

Whatever the choice, the renowned quality of Hitachi construction machinery is assured.



BUILDING A BETTER FUTURE

Established in 1910, Hitachi, Ltd. was built upon a founding philosophy of making a positive contribution to society through technology. This is still the inspiration behind the Hitachi group's reliable solutions that answer today's challenges and help to create a better world.

Hitachi, Ltd. is now one of the world's largest corporations, with a vast range of innovative products and services. These have been created to challenge convention, improve social infrastructure and contribute to a sustainable society.



Hitachi Construction Machinery Co., Ltd. (HCM) was founded in 1970 as a subsidiary of Hitachi, Ltd. and has become one of the world's largest construction equipment suppliers. A pioneer in producing hydraulic excavators, HCM also manufactures wheel loaders, rigid dump trucks, crawler cranes and special application machines at state-of-the-art facilities across the globe.

Incorporating advanced technology, Hitachi construction machinery has a reputation for the highest quality standards. Suitable for a wide range of industries, it is always

hard at work around the world – helping to create infrastructure for a safe and comfortable way of living, developing natural resources and supporting disaster relief efforts.

Hitachi ZW wheel loaders are renowned for being reliable, durable and versatile – capable of delivering the highest levels of productivity under the most challenging of conditions. They are designed to provide owners with a reduced total cost of ownership, and operators with the ultimate level of comfort and safety.

SPECIFICATIONS

Model Name: ZW180-6, EPA Tier 4 Final/EU Stage IV Certified

ENGINE

Gross power (ISO 14396)	173 HP/2,200 RPM (129 kW/2,200 RPM)
Net power (ISO 9249)	168 HP/2,200 RPM (125 kW/2,200 RPM)
Make/Model	Cummins QSB6.7 diesel engine
Type	4-cycle, water-cooled, direct injection with turbocharger and air cooled intercooler
Fuel type	#2 Diesel (Requires ultra-low sulfur fuel.)
Fuel injection pump	Electronically controlled, common rail type
Governor	All speed electrical type
Cooling module type	Forced circulation type
Number of cylinders	6
Bore and stroke	4.2" x 4.8" (107mm x 124mm)
Total displacement	408 in ³ (6.69 liters)
Alternator	DC 24V-65A (1.56 kW)
Air cleaner	Dry type (double element) with restriction indicator
Starter motor	DC 24V-10.5 HP (7.8 kW)
Battery	DC 12V-930 CCA (140 Ah), 2 units

TORQUE CONVERTER AND TRANSMISSION

Torque converter	3-element, single-stage, 1-phase
Transmission	Torque converter, countershaft type powershift with computer-controlled automatic shift and manual shift features included

	Normal Mode	Power Mode
Speeds: Forward	1st: 3.7 MPH (5.9 km/hr)	3.9 MPH (6.3 km/hr)
	2nd: 7.14 MPH (11.5 km/hr)	7.6 MPH (12.2 km/hr)
	3rd: 10.8 MPH (17.4 km/hr)	11.5 MPH (18.5 km/hr)
	4th: 15.7 MPH (25.3 km/hr)	16.8 MPH (27.0 km/hr)
	5th: 23.7 MPH (38.5 km/hr)	23.9 MPH (38.5 km/hr)
Speeds: Reverse	1st: 3.9 MPH (6.2 km/hr)	4.1 MPH (6.6 km/hr)
	2nd: 7.5 MPH (12.1 km/hr)	8.0 MPH (12.9 km/hr)
	3rd: 16.5 MPH (26.5 km/hr)	17.6 MPH (28.3 km/hr)

SYSTEMS REFILL CAPACITY

LOCATION	GALLONS	LITERS
Fuel tank (diesel fuel)	64.7	245
Engine lubricant (including oil pan)	6.6	25
Engine coolant	8.7	33
T/M & T/C	7.9	30
Axle (front/rear)	9.0/9.0	34/34
Hydraulic oil tank	26.4	100
Hydraulic system (including hydraulic tank)	39.6	150
DEF/AdBlue® tank	6.6	25

HYDRAULIC AND STEERING SYSTEM

Steering type	Articulated frame steering	
Steering mechanism	Hydraulic power steering unit, double-acting piston type	
Lift (boom) cylinder	Two (2) double-acting piston type: 4.9" x 30.1" (125mm x 765mm)	
Tilt (bucket) cylinder	One (1) double-acting piston type: 5.9" x 19.5" (150mm x 495mm)	
Steering cylinder	Two (2) double-acting piston type: 2.8" x 17.4" (70mm x 442mm)	
Main oil pump	Variable displacement axial plunger pump: 55 GPM/3,974 PSI @ 2,200 RPM (210 LPM/27.4 MPa @ 2,200 RPM)	
Fan oil pump	13.8 GPM/2,640 PSI @ 2,200 RPM (52.1 LPM/18.2 MPa @ 2,200 RPM)	
Pilot oil pump	Fixed displacement gear pump: 9.3 GPM/2,248 PSI @ 2,200 RPM (35.1 LPM/15.5 MPa @ 2,200 RPM)	
Relief valve set pressure	Control	27.4 MPa (280kgf/cm ²) 3,974 PSI (27.4 MPa)
	Priority	25.4 MPa (260kgf/cm ²) 3,684 PSI (25.4 MPa)

	HYDRAULIC CYCLE TIME* front end loading, Z bar linkage system	
	Normal Mode	Power Mode
Lifting time (at full load)	5.9 sec.	5.7 sec.
Lowering time (empty)	3.6 sec.	3.6 sec.
Bucket dumping time	1.3 sec.	1.3 sec.
TOTAL	10.8 sec.	10.6 sec.

* Measured in accordance with SAE J732C

AXLE SYSTEM

Drive system	4-wheel drive
Front and rear axle	Semi-floating type
Tires	20.5-25-12PR
Reduction and differential gear	Two-stage reduction with limited slip differential
Final reduction gear	Inboard mounted, heavy duty planetary gear
Oscillation angle	Total 24°(+12/-12)°

BRAKE SYSTEM

Service brakes	Inboard mounted fully hydraulic 4-wheel disc brake. Front and rear independent brake circuit.
Parking/Emergency brake	Spring-applied, hydraulically-released.

Remarks

- Materials and specifications are subject to change without notice and without any obligation on the part of the manufacturer.
- This information, while believed to be completely reliable, is not to be taken as warranty for which we assume legal responsibility.
- Dumping clearance and reach are measured from bucket edge in accordance with SAE J732C.
- Counterweight should not be used with tire ballast.
- This specification sheet may contain attachments and optional equipment not available in your area.

Please contact your local HCMA dealer for additional information.

BUCKET DATA

			Standard Arm				High Lift Arm
			General Purpose		Material Handling	Quick Coupler	Material Handling
			Straight Edge w/ Bolt-on Cutting Edge	Straight Edge w/ Teeth and Segments	Straight Edge w/ Bolt-on Cutting Edge	Straight Edge w/ Bolt-on Cutting Edge	Straight Edge w/ Bolt-on Cutting Edge
Capacity	Heaped	yd ³ (m ³)	3.7 (2.8)	3.7 (2.8)	4.2 (3.2)	3.4 (2.6)	3.7 (2.8)
	Struck	yd ³ (m ³)	3.3 (2.5)	3.3 (2.5)	3.5 (2.7)	3.0 (2.3)	3.3 (2.5)
A	Maximum dumping clearance	ft-in (mm)	9' (2,760)	8'11" (2,680)	8'1" (2,730)	8'11" (2,680)	10'5" (3,170)
B	Dumping reach (to front of bucket edge or tooth)	ft-in (mm)	3'8" (1,110)	3'1" (1,190)	3'11" (1,140)	3'1" (1,180)	4'2" (1,260)
C	Max. hinge pin height	ft-in (mm)	12'11" (3,920)	12'11" (3,920)	12'11" (3,920)	12'11" (3,920)	14'2" (4,320)
D	Digging depth (with bucket level)	in (mm)	4" (90)	4" (90)	4" (90)	4" (90)	6" (170)
Breakout force		lb (kN)	26,530 (118)	26,530 (118)	25,630 (114)	24,280 (108)	24,500 (109)
Bucket tilt-back angle	at ground level	degree	44°	44°	44°	44°	45°
	E at carry position	degree	50°	50°	50°	50°	50°
Overall	F Length	ft-in (mm)	26'4" (8,000)	26'8" (8,120)	26'6" (8,050)	26'8" (8,110)	27'1" (8,500)
	G Height (up to cab top)	ft-in (mm)	10'11" (3,280)	10'11" (3,280)	10'11" (3,280)	10'11" (3,280)	10'11" (3,280)
	H Height (bucket fully raised)	ft-in (mm)	17'4" (5,270)	17'4" (5,270)	17'6" (5,320)	17'6" (5,320)	18'8" (5,680)
	I Width (outside tire)	ft-in (mm)	8'7" (2,610)	8'7" (2,610)	8'7" (2,610)	8'7" (2,610)	8'7" (2,610)
	J Width (outside bucket)	ft-in (mm)	8'1" (2,730)	9' (2,760)	8'1" (2,730)	8'1" (2,730)	8'1" (2,730)
	K Tread	ft-in (mm)	6'10" (2,050)	6'10" (2,050)	6'10" (2,050)	6'10" (2,050)	6'10" (2,050)
L Wheel base	ft-in (mm)	10'2" (3,100)	10'2" (3,100)	10'2" (3,100)	10'2" (3,100)	10'2" (3,100)	
Clearance Circle (bucket carry position)	M at outside of bucket	ft-in (mm)	20'5" (6,230)	20'7" (6,280)	20'6" (6,240)	20'7" (6,260)	21'2" (6,440)
	at outside of tire	ft-in (mm)	18'4" (5,580)	18'4" (5,580)	18'4" (5,580)	18'4" (5,580)	18'4" (5,580)
N	Minimum ground clearance	ft-in (mm)	1'4" (395)	1'4" (395)	1'4" (395)	1'4" (395)	1'4" (395)
O	Full articulation angle	degree	40°	40°	40°	40°	40°
Operating weight (with ROPS cab)*		lb (kg)	32,100 (14,560)	32,170 (14,590)	32,280 (14,640)	32,650 (14,810)	32,540 (14,760)
Static tipping load (with ROPS cab)*	Straight	lb (kg)	26,680 (12,100)	26,590 (12,060)	26,540 (12,040)	24,600 (11,160)	21,050 (9,550)
	Full turn	lb (kg)	23,020 (10,440)	22,950 (10,410)	22,880 (10,380)	21,160 (9,600)	18,060 (8,190)

Note: All dimensions, weight and performance data based on ISO 6746-1:1987, ISO 7137:2009 and ISO 7546:1983

: Static tipping load and operating weight marked with include 20.5-25-12PR tires (No ballast) with lubricants, full fuel tank and operator.

Machine stability and operating weight depend on counterweight, tire size and other attachments.

DIMENSIONS

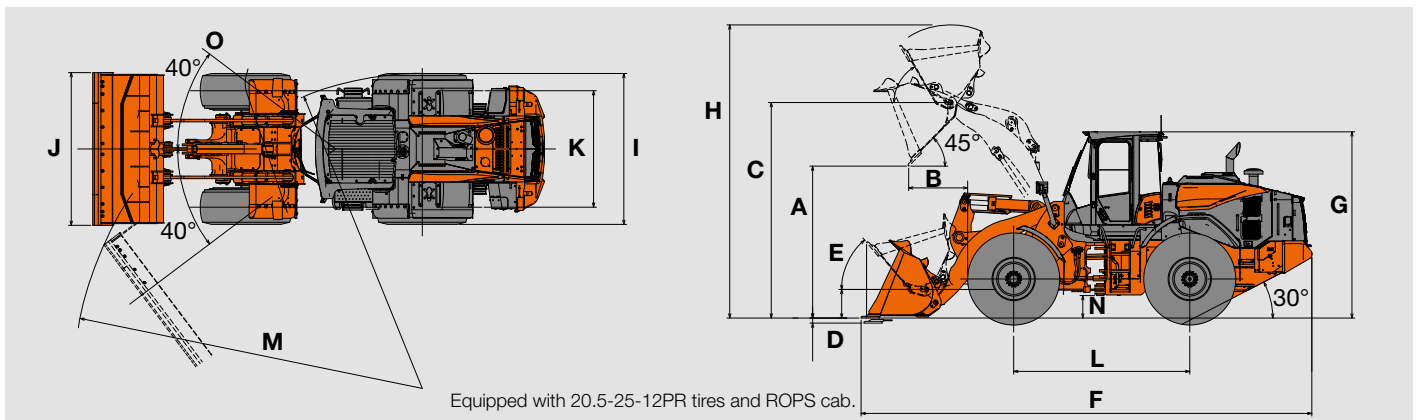

SPECIFICATIONS

ZW180 FORK SPECIFICATIONS

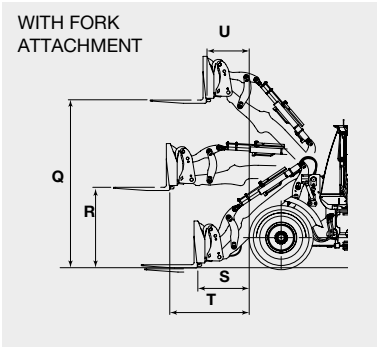

Attachment type		ISO (48)	416 (48)	ISO (60)	416 (60)
Q	Max. stacking height	ft	11'6"	11'6"	11'6"
R	Height of fork at maximum reach	ft (mm)	5'8"	5'10"	5'10"
S	Reach at ground level	ft (mm)	4'1"	3'8"	4'1"
T	Max. reach	ft (mm)	5'11"	5'7"	5'11"
U	Reach at max. stacking height	ft (mm)	3'2"	2'11"	3'2"
Static tipping load	Straight	lbf	16,482	16,755	15,620
	Full 40 degree turn	lbf	14,221	14,457	13,477
Max. payload per EN 474-3, 80 %		lb	11,377	11,566	10,782
Max. payload per EN 474-3, 60 %		lb (kg)	5,533	8,674	8,086
SAE allowable load		lb (kg)	7,111	7,228	6,769
Operating weight *		lb (kg)	31,540	31,526	31,642

BUCKET SELECTION CHART

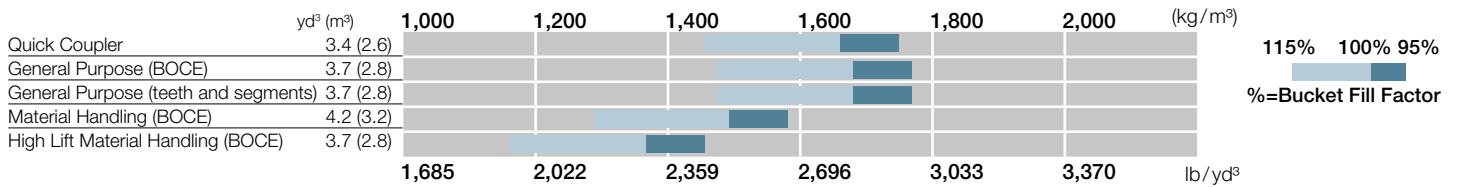

EQUIPMENT DATA

STANDARD EQUIPMENT

ENGINE

Air cleaner, double element
Auto idle shut down
Cold start (intake air heater)
Cooling fan, automatic reversible, swing-out type
Cummins QSB6.7 diesel engine
EGR (exhaust gas recirculation)
Fuel filter (main)
Fuel pre-filter, w/water separator
Pre-Cleaner (SyKlone)
SCR (selective catalytic reduction) catalyst and DOC (diesel oxidation catalyst)
VGT (variable geometry turbocharger)
Work mode selector

POWERTRAIN

Brakes, service
Enclosed wet disc
Dual system
Inboard mounted
Brake, parking
Spring applied
Oil pressure released
Dry disc type
Cooling cores, wide fin spacing (clog resistant)
Differential, limited slip (F/R)
Down-shift switch
Drive shafts, low maintenance
F-R direction selector (2-column mounted/HYD-control lever mounted)
1st speed hold switch on side console
Quick Power switch
Transmission, automatic w/load sensing system
Transmission declutch (3-position L/H/Off)
Transmission mode selection (3-position AUTO1/MAN/AUTO2)
Universal joints, sealed

HYDRAULIC SYSTEM

Boom kick-out, dual (operator adjustable in cab)
Bucket positioner (horizontal)
Control lever, single, pilot-assisted w/1 aux lever for 3rd function control
Control lever lock (electric)
Control valve, 3-spool, parallel and tandem control
Pump, variable displacement, load-sensing
Quick coupler control lines and controls
Ride control w/load sensing valve and automatic shut-off
Steering, direct
System; open-center, high-pressure, load-sensing

ELECTRICAL

24-volt electrical system
Back-up alarm
Batteries (2), 12V, 1000 CCA
Battery disconnect switch
Camera, rear-view
Converter, 12V/15 Amp
Horn, dual electric
Instrument panel, LCD, color
Lights:
2 Headlights (halogen)
2 Forward working lights (halogen)
4 Rear working lights (halogen)
2 Stop/tail/backup (halogen)
Turn signal w/4-way flashers/marker

CAB

ROPS cab: Enclosed cab with sound suppression, front & rear wipers and washers, two rear view and side mirrors, tinted glass, full view latch-back doors, sliding side windows.
Accessory outlet, 12V,
Adjustable armrest/console
Air conditioner/heater/pressurizer
AM/FM/WB radio with AUX input and Bluetooth
Ashtray
Cab dome lamps (2)
Cigarette lighter, 24V
Coat hook
Cup holder (2)
Floor mat, sweep-out
Retractable seat belt (3-inch)
ROPS/FOPS certified, ISO 3449 Level II compliance
Seat, premium, heated w/air ride suspension
Steering column, telescoping and tilting w/quick-release pedal
Storage box (heated/cooled)
Storage tray
Sun visor

OTHERS

Articulation locking bar
Counterweight
Drawbar
Engine block heater
Fenders, front, w/mudflap
Fenders, rear, deck-type, w/mudflap
Global e-Service, telematic monitoring system
Ladders, inclined
Lifting eyes
Linkage pins, HN bushing
Neutral safety start
Rear grill, steel
Steps, rear
Vandalism protection
Z-bar loader linkage

ALARMS, GAUGES, INDICATORS

Alarms (visual & audible)	Aftertreatment device
	Air cleaner element
	Axle oil temperature
	Battery discharge warning
	Brake oil low pressure
	CAN network system
	DEF/AdBlue tank level/quality/system
	Engine coolant temp
	Engine oil low pressure
	Engine trouble
	Engine warning
	Fuel filter (water in fuel)
	Hydraulic oil level
	Hydraulic oil temperature
Main pump oil pressure	
Transmission oil temp	
Transmission warning	
Gauges	DEF/AdBlue tank level
	Engine coolant temperature
	Fuel gauge
	Speedometer
	Tachometer
Indicators	Transmission oil temperature
	Aftertreatment device regeneration
	Air conditioner display
	Auto idle shutdown
	Boom kick-out, dual
	Cold start
	Control lever lock
	Declutch
	Eco-operating status
	Fan reverse rotation
	F-N-R selection
	F-N-R switch enable
	High beam
	Parking brake
	Shift hold
	Time/operating hour/ODO
	Transmission mode and status
Turn signal w/4-way flashers/marker	
Work light	
Work mode (Normal, Power)	

OPTIONAL EQUIPMENT

Belly guard, front chassis, transmission (rear)
Bolt-on cutting edges
Cooling cores, standard spacing (high ambient)
Counterweight for logging
Dual lever hydraulic control
Fenders, rear, full, w/mudflap
4th function control
Global e-Service (satellite version)
Heated mirrors
High lift arm
Quick coupler and attachments
Radiator area screen guard
Wheel seal guards

Standard and optional equipment may vary by country, so please consult your Hitachi dealer for details.



HITACHI

Reliable solutions



REPUTATIONS ARE
BUILT ON IT.

With manufacturing facilities in Banshu, Ryugasaki, Tierra, and Hitachinaka, Japan, and the U.S. corporate office and campus in Newnan, Georgia, Hitachi Construction Machinery Americas Inc. (HCMA) has the experience and technology to design, engineer, manufacture, and service your Hitachi construction machinery. The HCMA team is securely poised as your go-to source in the North American and Latin American construction machinery market.

Through our long-term commitment to maintaining a leadership position in technology, service, and support, HCMA supports an extensive network of independent, local dealers focused on providing you with knowledgeable and experienced sales, service, and parts personnel. All backed by dedicated HCMA support teams.

Your HCMA dealer has the resources, expertise and personnel to work with you to ensure that you receive the most benefit from your Hitachi investment utilizing carefully designed programs and services in conjunction with extensive digital resources. HCMA provides a totally focused approach to supporting you, your business, and your Hitachi construction machinery.

Machines representative of global product. Options may not be available in all markets. Prior to operating this machine, including satellite communication system, in a country other than a country of its intended use, it may be necessary to make modifications to it so that it complies with the local regulatory standards (including safety standards) and legal requirements of that particular country. Please do not export or operate this machine outside the country of its intended use until such compliance has been confirmed. Please contact your Hitachi dealer in case of questions about compliance.