

# CD160M Dri-Prime® Pump

The Godwin Dri-Prime CD160M pump offers flow rates to 1880 USGPM and has the capability of handling solids up to 3.0" in diameter.

The CD160M is able to automatically prime to 28' of suction lift from dry. Automatic or manual starting/stopping available through integral mounted control panel or optional wireless-remote access.

Indefinite dry-running is no problem due to the unique Godwin liquid bath mechanical seal design. Solids handling, dry-running, and portability make the CD160M the perfect choice for dewatering and bypass applications.

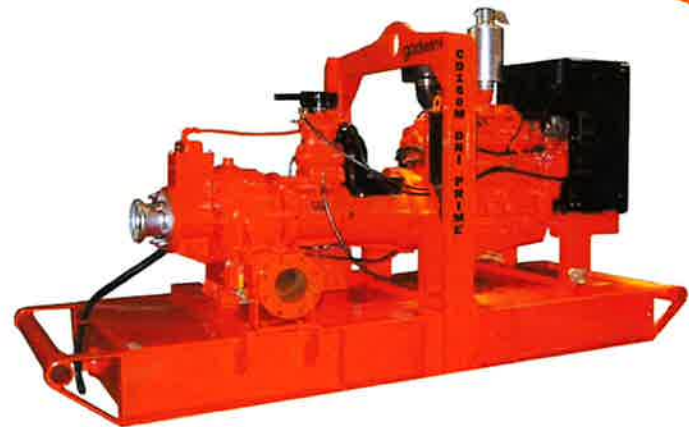

## Features and Benefits

- Simple maintenance normally limited to checking fluid levels and filters.
- Dri-Prime (continuously operated Venturi air ejector priming device) requiring no periodic adjustment. Optional compressor clutch available.
- Extensive application flexibility handling sewage, slurries, and liquids with solids up to 3.0" in diameter.
- Dry-running high pressure liquid bath mechanical seal with high abrasion resistant solid silicon carbide faces.
- Close-coupled centrifugal pump with Dri-Prime system coupled to a diesel engine or electric motor.
- All cast iron construction (stainless steel construction option available) with cast steel impeller.
- Also available in a critically silenced unit which reduces noise levels to less than 70 dBA at 30'.
- Standard engine John Deere 6068HF285 (T3 Flex). Also available with John Deere 6068HC93 (IT4).

## Specifications

Suction connection	6" 150# ANSI B16.5
Delivery connection	6" 150# ANSI B16.5
Max capacity	1880 USGPM †
Max solids handling	3.0"
Max impeller diameter	14.0"
Max operating temp	176°F*
Max pressure	115 psi
Max suction pressure	73 psi
Max casing pressure	173 psi
Max operating speed	2000 rpm

\* Please contact our office for applications in excess of 176°F.

† Larger diameter pipes may be required for maximum flows.

Please contact the factory or office for further details. A typical picture of the pump is shown. All information is approximate and for general guidance only.

godwin   
a xylem brand

## Performance Curve

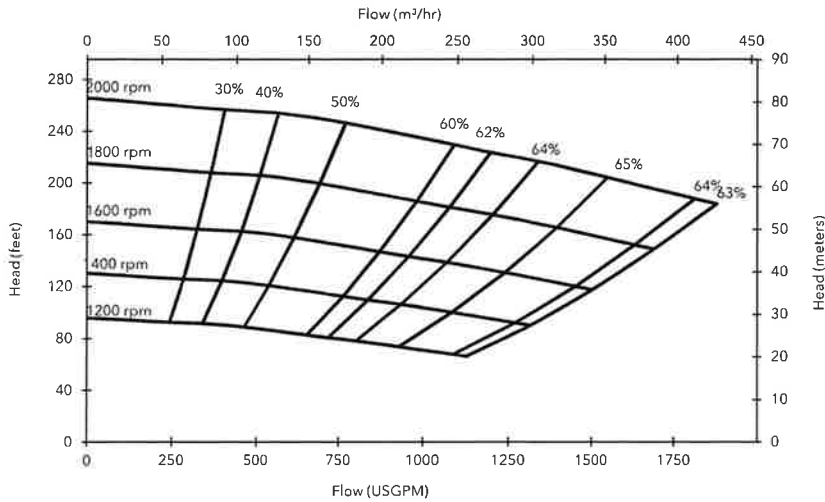

## Materials

Pump casing & suction cover	Cast iron BS EN 1561 - 1997
Wearplates	Cast iron BS EN 1561 - 1997
Pump Shaft	Carbon steel BS 970 - 1991 817M40T
Impeller	Cast Steel BS3100 A5 Hardness to 200 HB Brinell
Non-return valve body	Cast iron BS EN 1561 - 1997
Mechanical seal	Silicon carbide face; Viton elastomers; Stainless steel body

### Engine option 1

John Deere 6068HF285 (T3 Flex), 149 HP @ 2000 rpm

Impeller diameter 14.0"

Pump speed 2000 rpm

#### Suction Lift Table

Total Suction Head (feet)	Total Delivery Head (feet)				
	144	185	201	221	245
	Output (USGPM)				
10	2006	1712	1468	1027	489
15	2006	1614	1370	734	367
20	2006	1517	1223	612	-
25	1614	1223	1076	489	-

Fuel capacity: 180 US Gal

Max Fuel consumption @ 2000 rpm: 8.0 US Gal/hr

Max Fuel consumption @ 1600 rpm: 7.0 US Gal/hr

Weight (Dry): 5,610 lbs

Weight (Wet): 6,910 lbs

Dim.: (L) 147" x (W) 56" x (H) 84"

Performance data provided in tables is based on water tests at sea level and 20°C ambient. All information is approximate and for general guidance only. Please contact the factory or office for further details.

### Engine option 2

John Deere 6068HC93 (IT4), 156 HP @ 2000 rpm

Impeller diameter 14.0"

Pump speed 2000 rpm

#### Suction Lift Table

Total Suction Head (feet)	Total Delivery Head (feet)				
	144	185	201	221	245
	Output (USGPM)				
10	2006	1712	1468	1027	489
15	2006	1614	1370	734	367
20	2006	1517	1223	612	-
25	1614	1223	1076	489	-

Fuel capacity: 180 US Gal

Max Fuel consumption @ 2000 rpm: 7.9 US Gal/hr

Max Fuel consumption @ 1600 rpm: 6.8 US Gal/hr

Weight (Dry): 6,270 lbs

Weight (Wet): 7,570 lbs

Dim.: (L) 147" x (W) 56" x (H) 84"

Performance data provided in tables is based on water tests at sea level and 20°C ambient. All information is approximate and for general guidance only. Please contact the factory or office for further details.

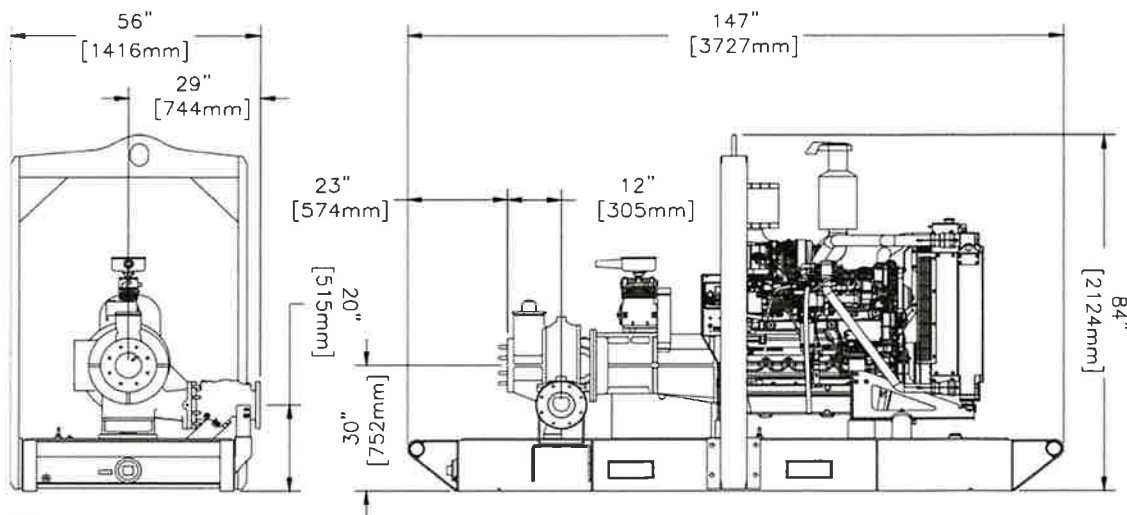

**xylem**  
Let's Solve Water

34 Floodgate Road  
Bridgeport, NJ 08014 USA  
(856) 467-3636 Fax (856) 467-4841  
Email: sales@godwinpumps.com

Reference number : 95-1012-3000  
Date of issue : February 26, 2014  
Issue : 5

[www.godwinpumps.com](http://www.godwinpumps.com)