



202 Winston Creek Parkway
Lakeland, FL 33810-2866
Tel: 863-682-8800
Fax: 863-682-5200
www.godwinpumps.com

November 14, 2024

Mr. Ray Morales
Town of Dundee
603 Main Street
Dundee, FL 33838

Phone: 863-289-0755
Email: rmorales@townofdundee.com

**RE: CD160M-CS - FSA
Sale Quotation 119033933**

Dear Mr. Morales:

Thank you for your interest in Xylem Dewatering Solutions, Inc and our Godwin Pumps line of Dri-Prime pumps.

As requested, please see the attached sale pricing for our CD160M Critically Silenced Diesel Pump with trailer and requested options.

The Critically Silenced unit is engineered from start to finish for quiet operation. The enclosure consists of 14 gauge sheet metal lined with 1" and 2" layers of polydamp acoustical sound deadening material. The engine is designed with a critical grade silenced muffler, silenced the priming exhaust, and isolated engine vibration to further reduce operating noise. Hinged, lockable doors provide convenient access to operating controls and service locations. Sound levels are approximately 69 dBA at 30 feet.

The pricing is based on the Florida Sheriff's Contract #FSA23-EQU21.0, Item #313. There are no delivery / freight charges when utilizing the FSA Contract.

Should you require further information or have any questions, please do not hesitate to contact me.

Sincerely,

Tyler Bixler
Outside Sales Representative

TB / gy

Home Office:

84 Floodgate Road, Bridgeport, NJ 08014 • www.godwinpumps.com • (856) 467-3636 • (856) 467-4841



SALE QUOTATION

ITEM	QTY	DESCRIPTION
Contract Items:		
A	1	Dri-Prime CD160M Critically Silenced <ul style="list-style-type: none"> • Sound Attenuated Enclosure • 6" 150# Flange Suction and Discharge • John Deere 4045HFC04-FT4 134HP Diesel • Includes PrimeGuard Engine Controller • Skid-mounted • Engine/Motor Options <ul style="list-style-type: none"> • Xylem FST New Equip Package - FOR USA
B	1	HS300/HL5M/6M SAE GL12 Trailer (7754)
C	1	PrimeGuard Float Set <ul style="list-style-type: none"> • w/ 65' Mechanical Floats

THE PRICE PROVIDED IS BASED UPON XYLEM'S REVIEW OF THE APPLICABLE PLAN DRAWINGS AND RELEVANT TECHNICAL SPECIFICATION SECTIONS BEARING ON THE EQUIPMENT DESCRIBED IN THIS QUOTATION. SUBMISSION OF THIS QUOTATION SHOULD NOT BE MISCONSTRUED AS XYLEM'S ACCEPTANCE OF ANY OTHER PROVISIONS OF THE PRIME CONTRACT BETWEEN CONTRACTOR AND PROJECT OWNER (HOWSOEVER REFERENCED) AND ATTEMPTS IN ANY SUBSEQUENT SUBCONTRACT TO BIND XYLEM TO SUCH OWNER DOCUMENTS ARE HEREBY REJECTED AND SHALL BE OF NO FORCE AND EFFECT, IRRESPECTIVE OF ANYTHING STATED ELSEWHERE TO THE CONTRARY.

This pricing information is for internal use only. We ask that these items and terms be kept confidential. All quotations are subject to credit approval. All prices quoted in US dollars.



SALE QUOTATION

ITEM	QTY	DESCRIPTION		
<p>Our current delivery lead-times associated with this Quotation are best estimates at this time. Due to the outbreak of the COVID-19 virus pandemic and its global effects on commerce, supply chain, and logistics, these lead-times are an estimate only and not a commitment. Xylem is and will continue to use all commercially reasonable efforts to minimize any delivery delay impacts.</p>				
<p>A signed copy of this Quotation is acceptable as a binding contract.</p> <table border="1" style="width: 100%; border-collapse: collapse;"> <tr> <td style="width: 50%; vertical-align: top;"> <p>Signature: _____</p> <p>Company/Utility: _____</p> <p>Address: _____</p> <p>_____</p> <p>_____</p> </td> <td style="width: 50%; vertical-align: top;"> <p>Name: (PLEASE PRINT) _____</p> <p>Reference #: _____</p> <p>Date: _____</p> <p>Phone: _____</p> <p>Email: _____</p> <p>Fax: _____</p> </td> </tr> </table>			<p>Signature: _____</p> <p>Company/Utility: _____</p> <p>Address: _____</p> <p>_____</p> <p>_____</p>	<p>Name: (PLEASE PRINT) _____</p> <p>Reference #: _____</p> <p>Date: _____</p> <p>Phone: _____</p> <p>Email: _____</p> <p>Fax: _____</p>
<p>Signature: _____</p> <p>Company/Utility: _____</p> <p>Address: _____</p> <p>_____</p> <p>_____</p>	<p>Name: (PLEASE PRINT) _____</p> <p>Reference #: _____</p> <p>Date: _____</p> <p>Phone: _____</p> <p>Email: _____</p> <p>Fax: _____</p>			

NET LUMP SUM SALE TOTAL

\$ 133,864.62

THE PRICE PROVIDED IS BASED UPON XYLEM'S REVIEW OF THE APPLICABLE PLAN DRAWINGS AND RELEVANT TECHNICAL SPECIFICATION SECTIONS BEARING ON THE EQUIPMENT DESCRIBED IN THIS QUOTATION. SUBMISSION OF THIS QUOTATION SHOULD NOT BE MISCONSTRUED AS XYLEM'S ACCEPTANCE OF ANY OTHER PROVISIONS OF THE PRIME CONTRACT BETWEEN CONTRACTOR AND PROJECT OWNER (HOWSOEVER REFERENCED) AND ATTEMPTS IN ANY SUBSEQUENT SUBCONTRACT TO BIND XYLEM TO SUCH OWNER DOCUMENTS ARE HEREBY REJECTED AND SHALL BE OF NO FORCE AND EFFECT, IRRESPECTIVE OF ANYTHING STATED ELSEWHERE TO THE CONTRARY.

This pricing information is for internal use only. We ask that these items and terms be kept confidential. All quotations are subject to credit approval. All prices quoted in US dollars.

godwin

QUOTE PER THE FLORIDA SHERIFF'S ASSOCIATION CONTRACT

Quote Prepared For: City of Dundee

Attention: Mr. Morales

Date: 11/14/2024 Quote #119033933

CONTRACT DETAILS

FLORIDA SHERIFF'S ASSOC., FLORIDA ASSOC. OF COUNTIES & FLORIDA FIRE CHIEFS' ASSOCIATION			
BID #: FSA23-EQU21.0			
Item #:313, 6 INCH MOBILE PUMP PACKAGE			
EFFECTIVE: OCTOBER 1, 2023 THROUGH SEPTEMBER 30, 2025			

CONTRACT PRICING

BASE	BASE BID - Godwin CD150S 6" Isuzu FT4 Dri-Prime Diesel Pump-Trailer	1	50,119.00	50,119.00
ADD	Upgrade to CD160M-CS 6" FT4 JD / Trailer	1	79,795.61	79,795.61
CONTRACT PRICING TOTAL				129,914.61

SPECIFIED OPTIONS

		QTY	UNIT PRICE	
CAPGMA005	PrimeGuard Float Set	1	489.21	489.21
SUB TOTAL				489.21
SPECIFIED OPTIONS TOTAL				489.21

NON-SPECIFIED OPTIONS

		QTY	UNIT PRICE	
	Xylem FST New Equip Package	1	4,326.00	4,326.00
SUB TOTAL				4,326.00
20%	Contract Discount			865.20
NON-SPECIFIED OPTIONS TOTAL				3,460.80

TOTAL CD160M-CS

133,864.62

Xylem Dewatering Solutions / Godwin Pumps appreciates the opportunity to assist with the above quote per the Florida Sheriff's Association. We look forward to serving your needs throughout the future.

CD160M Dri-Prime® Pump

The Godwin Dri-Prime CD160M pump offers flow rates to 1880 USGPM and has the capability of handling solids up to 3.0" in diameter.

The CD160M is able to automatically prime to 28' of suction lift from dry. Automatic or manual starting/stopping available through integral mounted control panel or optional wireless-remote access.

Indefinite dry-running is no problem due to the unique Godwin liquid bath mechanical seal design. Solids handling, dry-running, and portability make the CD160M the perfect choice for dewatering and bypass applications.

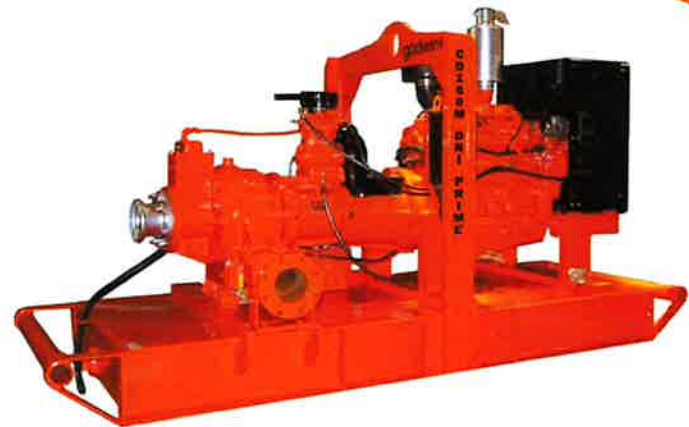

Features and Benefits

- Simple maintenance normally limited to checking fluid levels and filters.
- Dri-Prime (continuously operated Venturi air ejector priming device) requiring no periodic adjustment. Optional compressor clutch available.
- Extensive application flexibility handling sewage, slurries, and liquids with solids up to 3.0" in diameter.
- Dry-running high pressure liquid bath mechanical seal with high abrasion resistant solid silicon carbide faces.
- Close-coupled centrifugal pump with Dri-Prime system coupled to a diesel engine or electric motor.
- All cast iron construction (stainless steel construction option available) with cast steel impeller.
- Also available in a critically silenced unit which reduces noise levels to less than 70 dBA at 30'.
- Standard engine John Deere 6068HF285 (T3 Flex). Also available with John Deere 6068HC93 (IT4).

Specifications

Suction connection	6" 150# ANSI B16.5
Delivery connection	6" 150# ANSI B16.5
Max capacity	1880 USGPM †
Max solids handling	3.0"
Max impeller diameter	14.0"
Max operating temp	176°F*
Max pressure	115 psi
Max suction pressure	73 psi
Max casing pressure	173 psi
Max operating speed	2000 rpm

* Please contact our office for applications in excess of 176°F.

† Larger diameter pipes may be required for maximum flows.

Performance Curve

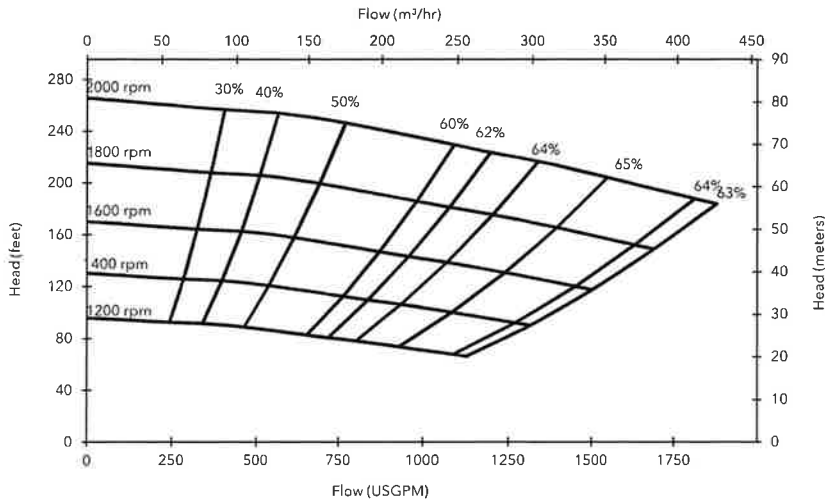

Materials

Pump casing & suction cover	Cast iron BS EN 1561 - 1997
Wearplates	Cast iron BS EN 1561 - 1997
Pump Shaft	Carbon steel BS 970 - 1991 817M40T
Impeller	Cast Steel BS3100 A5 Hardness to 200 HB Brinell
Non-return valve body	Cast iron BS EN 1561 - 1997
Mechanical seal	Silicon carbide face; Viton elastomers; Stainless steel body

Engine option 1

John Deere 6068HF285 (T3 Flex), 149 HP @ 2000 rpm

Impeller diameter 14.0"

Pump speed 2000 rpm

Suction Lift Table

Total Suction Head (feet)	Total Delivery Head (feet)				
	144	185	201	221	245
	Output (USGPM)				
10	2006	1712	1468	1027	489
15	2006	1614	1370	734	367
20	2006	1517	1223	612	-
25	1614	1223	1076	489	-

Fuel capacity: 180 US Gal

Max Fuel consumption @ 2000 rpm: 8.0 US Gal/hr

Max Fuel consumption @ 1600 rpm: 7.0 US Gal/hr

Weight (Dry): 5,610 lbs

Weight (Wet): 6,910 lbs

Dim.: (L) 147" x (W) 56" x (H) 84"

Performance data provided in tables is based on water tests at sea level and 20°C ambient. All information is approximate and for general guidance only. Please contact the factory or office for further details.

Engine option 2

John Deere 6068HC93 (IT4), 156 HP @ 2000 rpm

Impeller diameter 14.0"

Pump speed 2000 rpm

Suction Lift Table

Total Suction Head (feet)	Total Delivery Head (feet)				
	144	185	201	221	245
	Output (USGPM)				
10	2006	1712	1468	1027	489
15	2006	1614	1370	734	367
20	2006	1517	1223	612	-
25	1614	1223	1076	489	-

Fuel capacity: 180 US Gal

Max Fuel consumption @ 2000 rpm: 7.9 US Gal/hr

Max Fuel consumption @ 1600 rpm: 6.8 US Gal/hr

Weight (Dry): 6,270 lbs

Weight (Wet): 7,570 lbs

Dim.: (L) 147" x (W) 56" x (H) 84"

Performance data provided in tables is based on water tests at sea level and 20°C ambient. All information is approximate and for general guidance only. Please contact the factory or office for further details.

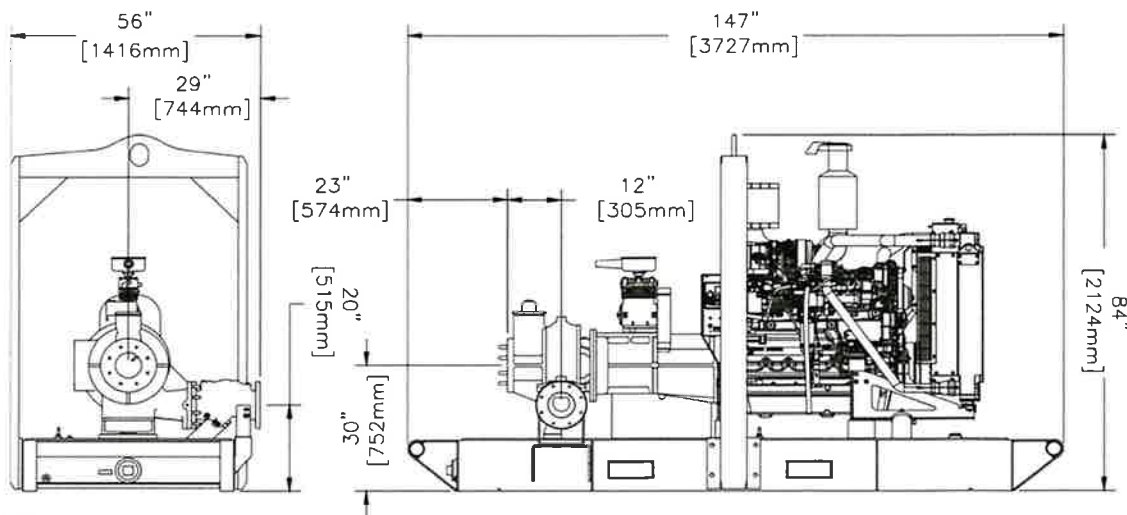

xylem
Let's Solve Water

34 Floodgate Road
Bridgeport, NJ 08014 USA
(856) 467-3636 Fax (856) 467-4841
Email: sales@godwinpumps.com

Reference number: 95-1012-3000

Date of issue: February 26, 2014

Issue: 5

www.godwinpumps.com