



BID FORM

**FY 2024-2025 DESIGN, CONSTRUCTION, AND INSTALLATION OF
SPLASH PAD AND PLAYGROUND WITH PARK EQUIPMENT**

RETURN DATE: WEDNESDAY, JULY 3, 2024 BY 3:00 P.M.

RETURN TO: Office of the Town Clerk
Attn: RFP #24-07
Town of Dundee
P.O. Box 1000
202 East Main Street
Dundee, Florida 33838

ITEM	ESTIMATED QTY	UNIT BID	EXTENDED AMOUNT
1.	See attached		
2.			
3.			
4.			
5.			See attached
		TOTAL	950,000.00

ALL BID FORMS SHOULD INCLUDE THE FOLLOWING INFORMATION:

Company Submitting Bid: JCR Construction & Services LLC
Company Address: 3804 Block Prime Rd
Company City: Lakeland State: FL Zip: 33810
Company Phone Number: (863) 660-4704 Fax Number: N/A

Authorized Representative:

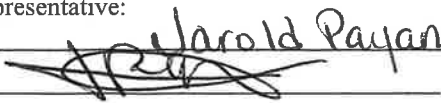
Signature:  Date: 7-11-24

Print Name: Harold Payan Phone Number: (863) 660-4704
Title: President

JCR Construction & Services LLC.
3804 Block Prine Rd
FL 33810
jcrconstructionservices@gmail.com



ADDRESS

Town Of Dundee
4th Street Park
501 4th Street South
Dundee, Florida 33838

ESTIMATE # 4279

DATE 07/21/2024

ACTIVITY	QUANTITY	RATE	AMOUNT
Services			950,000.00
45,000 Civil Engineering Drawings			
25,000 Architectural Drawings and Specifications			
200,000 Splash Pad			
60,000 Playground			
345,000 Site work			
80,000 Restroom			
105,000 Pavilion			
30,000 Performance Bond			
60,000 Supervision and Project Management			
950,000 Total			
TOTAL			\$950,000.00

Accepted By

Accepted Date

JCR Construction & Services LLC. 3804 Block Prine Rd FL 33810

Town of Dundee
202 East Main St
Dundee, FL 33838

Dear Madam & Sir,

I would like to bring attention to a few items to explain why the price is so different from the \$400k + budget you initially thought the Design, Construction, and Installation of Splash Pad and Playground with Park Equipment- RFP #24-07 would be.

First, this is a project that will take well over a year to complete. If we count the state regulations, FEMA approval, and drawings process. It will take up to 8 weeks just to receive construction drawings, civil drawings and permit approval. The project after we have a permit should be 11-12 months to completion.

Second, the splash pad is like a gigantic pool, but with a more complex system of sanitation and is regulated by the health department. The filtration systems are needed together with the combination of sanitation of the water, etc., is complex and expensive.

In addition, the lot where the splash pad will be built has a significant differentiation of level in some areas, up to 8 feet in difference. We must move all that soil and bring in dirt to fill up the hole.

We also have a big parking lot, a pavilion, and a solid block building to accommodate the ADA bathrooms and family bathrooms.

On top of that, we need to secure the entire perimeter with a chain-link fence on the entire property and add a playground. This is a complex job, very different from what we have done in the town of Dundee.

We are confident we can work with the Town on the details to continue making Dundee beautiful.

If we are selected to do the job, we will present the project with the architect to explain all the processes, the different roles of each department, and the schedule for the job at the commission meeting.

Sincerely,

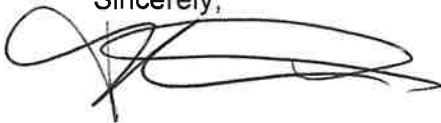

Jarold Payan
JCR Construction & Services

TIMELINE

Town of Dundee for FY 2024-2025 DESIGN, CONSTRUCTION, AND INSTALLATION OF SPLASH PAD AND PLAYGROUND WITH PARK EQUIPMENT

Please note that the civil drawings and review from the State of Florida and FEMA are required. Civil drawings could take 2 months to obtain. Upon the approval of the civil drawings and architectural drawings a permit can be applied for from the Town of Dundee as well as the Florida Department of Health. The time for these to process will depend on the Town and State offices procedures; it is estimated to take 10 months. After these permits are received, it will be approximately 8 months to complete the project. Please note that these are a tentative timeline and upon award of the bid, JCR Construction will have a schedule in place and will keep the Town of Dundee updated with the timeline as we follow State of Florida regulations and requirements for the project.

THE AMERICAN INSTITUTE OF ARCHITECTS

AIA Document A310

Bid Bond

KNOW ALL MEN BY THESE PRESENTS, that we
JCR Construction and Services LLC
4822 Joyce Dr,
Lakeland, FL 33805

as Principal, hereinafter called the Principal, and
The Ohio Casualty Insurance Company
9721 Executive Center Drive, Suite 105
St. Petersburg, FL 33702

a corporation duly organized under the laws of the State of NH
as Surety, hereinafter called the Surety, are held and firmly bound unto
The Town of Dundee, Florida
202 East Main Street, PO Box 1000
Dundee, FL 33838

as Obligee, hereinafter called the Obligee, in the sum of **Five Percent of Amount Bid in U.S. Dollars (\$5%)** for
the payment of which sum well and truly to be made, the said Principal and the said Surety, bind ourselves, our
heirs, executors, administrators, successors and assigns, jointly and severally, firmly by these presents.

WHEREAS the Principal has submitted a bid for
Design Construction & Installation of Splash Pad(s); Bid No. 24-07
Installation of Splash Pad(s), Restrooms, Playground & Pavilion
501 4th Street South, Dundee, FL 33838

NOW, THEREFORE, if the Obligee shall accept the bid of the Principal and the Principal shall enter into a
Contract with the Obligee in accordance with the terms of such bid, and give such bond or bonds as may be
specified in the bidding or Contract Documents with good and sufficient surety for the faithful performance of
such Contract and for the prompt payment of labor and material furnished in the prosecution thereof, or in the
event of the failure of the Principal to enter such Contract and give such bond or bonds, if the Principal shall
pay to the Obligee the difference not to exceed the penalty hereof between the amount specified in said bid and
such larger amount for which the Obligee may in good faith contract with another party to perform the Work
covered by said bid, then this obligation shall be null and void, otherwise to remain in full force and effect.

Signed and sealed July 24, 2024

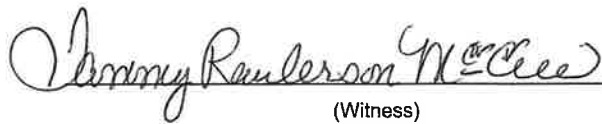
(Witness)

(Witness)

JCR Construction and Services LLC



The Ohio Casualty Insurance Company



David B. Shick, Attorney-In-Fact and
Licensed FL Resident Agent #A241176



Seal No. 7503



This Power of Attorney limits the acts of those named herein, and they have no authority to bind the Company except in the manner and to the extent herein stated.

Liberty Mutual Insurance Company
The Ohio Casualty Insurance Company
West American Insurance Company

Certificate No: 8205203-969456

POWER OF ATTORNEY

KNOWN ALL PERSONS BY THESE PRESENTS: That The Ohio Casualty Insurance Company is a corporation duly organized under the laws of the State of New Hampshire, that Liberty Mutual Insurance Company is a corporation duly organized under the laws of the State of Massachusetts, and West American Insurance Company is a corporation duly organized under the laws of the State of Indiana (herein collectively called the "Companies"), pursuant to and by authority herein set forth, does hereby name, constitute and appoint, Brandy Baich, David B. Shick

all of the city of Tampa state of FL each individually if there be more than one named, its true and lawful attorney-in-fact to make, execute, seal, acknowledge and deliver, for and on its behalf as surety and as its act and deed, any and all undertakings, bonds, recognizances and other surety obligations, in pursuance of these presents and shall be as binding upon the Companies as if they have been duly signed by the president and attested by the secretary of the Companies in their own proper persons.

IN WITNESS WHEREOF, this Power of Attorney has been subscribed by an authorized officer or official of the Companies and the corporate seals of the Companies have been affixed thereto this 5th day of April, 2021.



Liberty Mutual Insurance Company
The Ohio Casualty Insurance Company
West American Insurance Company

By: David M. Carey, Assistant Secretary

Not valid for mortgage, note, loan, letter of credit, currency rate, interest rate or residual value guarantees.

State of PENNSYLVANIA
County of MONTGOMERY ss

On this 5th day of April, 2021 before me personally appeared David M. Carey, who acknowledged himself to be the Assistant Secretary of Liberty Mutual Insurance Company, The Ohio Casualty Company, and West American Insurance Company, and that he, as such, being authorized so to do, execute the foregoing instrument for the purposes therein contained by signing on behalf of the corporations by himself as a duly authorized officer.

IN WITNESS WHEREOF, I have hereunto subscribed my name and affixed my notarial seal at King of Prussia, Pennsylvania, on the day and year first above written.



Commonwealth of Pennsylvania - Notary Seal
Teresa Pastella, Notary Public
Montgomery County
My commission expires March 28, 2025
Commission number 1126044
Member, Pennsylvania Association of Notaries

By: Teresa Pastella, Notary Public

This Power of Attorney is made and executed pursuant to and by authority of the following By-laws and Authorizations of The Ohio Casualty Insurance Company, Liberty Mutual Insurance Company, and West American Insurance Company which resolutions are now in full force and effect reading as follows:

ARTICLE IV - OFFICERS: Section 12. Power of Attorney.

Any officer or other official of the Corporation authorized for that purpose in writing by the Chairman or the President, and subject to such limitation as the Chairman or the President may prescribe, shall appoint such attorneys-in-fact, as may be necessary to act in behalf of the Corporation to make, execute, seal, acknowledge and deliver as surety any and all undertakings, bonds, recognizances and other surety obligations. Such attorneys-in-fact, subject to the limitations set forth in their respective powers of attorney, shall have full power to bind the Corporation by their signature and execution of any such instruments and to attach thereto the seal of the Corporation. When so executed, such instruments shall be as binding as if signed by the President and attested to by the Secretary. Any power or authority granted to any representative or attorney-in-fact under the provisions of this article may be revoked at any time by the Board, the Chairman, the President or by the officer or officers granting such power or authority.

ARTICLE XIII - Execution of Contracts: Section 5. Surety Bonds and Undertakings.

Any officer of the Company authorized for that purpose in writing by the chairman or the president, and subject to such limitations as the chairman or the president may prescribe, shall appoint such attorneys-in-fact, as may be necessary to act in behalf of the Company to make, execute, seal, acknowledge and deliver as surety any and all undertakings, bonds, recognizances and other surety obligations. Such attorneys-in-fact subject to the limitations set forth in their respective powers of attorney, shall have full power to bind the Company by their signature and execution of any such instruments and to attach thereto the seal of the Company. When so executed such instruments shall be as binding as if signed by the president and attested by the secretary.

Certificate of Designation - The President of the Company, acting pursuant to the Bylaws of the Company, authorizes David M. Carey, Assistant Secretary to appoint such attorneys-in-fact as may be necessary to act on behalf of the Company to make, execute, seal, acknowledge and deliver as surety any and all undertakings, bonds, recognizances and other surety obligations.

Authorization - By unanimous consent of the Company's Board of Directors, the Company consents that facsimile or mechanically reproduced signature of any assistant secretary of the Company, wherever appearing upon a certified copy of any power of attorney issued by the Company in connection with surety bonds, shall be valid and binding upon the Company with the same force and effect as though manually affixed.

I, Renee C. Llewellyn, the undersigned, Assistant Secretary, The Ohio Casualty Insurance Company, Liberty Mutual Insurance Company, and West American Insurance Company do hereby certify that the original power of attorney of which the foregoing is a full, true and correct copy of the Power of Attorney executed by said Companies, is in full force and effect and has not been revoked.

IN TESTIMONY WHEREOF, I have hereunto set my hand and affixed the seals of said Companies this 24 day of July, 2024.



By: Renee C. Llewellyn, Assistant Secretary



For bond and/or Power of Attorney (POA) verification inquiries, please call 610-832-8240 or email HOSUR@libertymutual.com.

RFP 24-07
Exhibit "A"

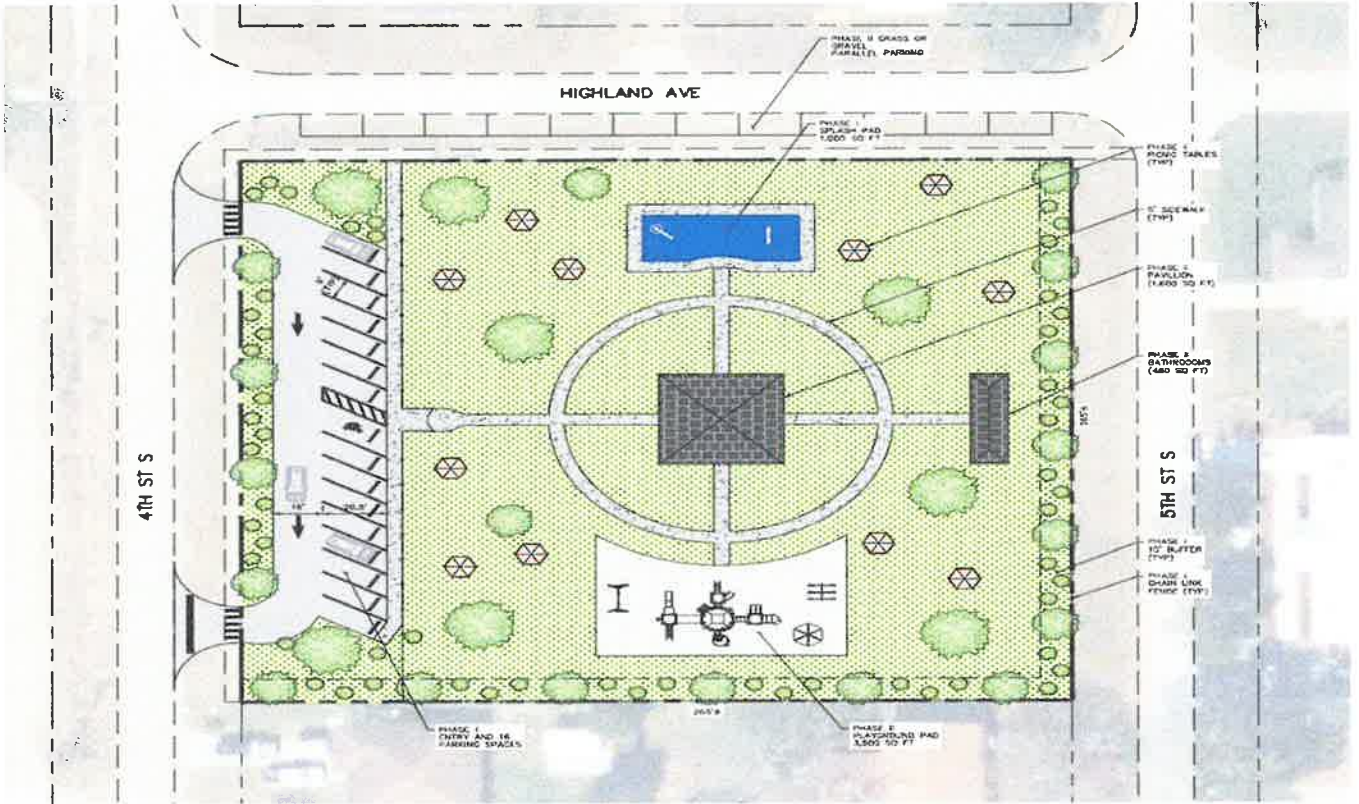

AFFIDAVIT CERTIFICATION
IMMIGRATION LAWS

THE TOWN OF DUNDEE, FLORIDA, WILL NOT INTENTIONALLY AWARD TOWN CONTRACTS TO ANY CONTRACTOR WHO KNOWINGLY EMPLOYS UNAUTHORIZED ALIEN WORKERS, CONSTITUTING A VIOLATION OF THE EMPLOYMENT PROVISIONS CONTAINED IN 8 U.S.C. SECTION 1324 a(e) AND/OR SECTION 274A(e) OF THE IMMIGRATION AND NATIONALITY ACT ("INA").

THE TOWN OF DUNDEE, FLORIDA, MAY CONSIDER THE EMPLOYMENT BY ANY CONTRACTOR OF UNAUTHORIZED ALIENS A VIOLATION OF SECTION 274A(e) OF THE INA. **SUCH VIOLATION BY THE RECIPIENT OF THE EMPLOYMENT PROVISIONS CONTAINED IN SECTION 274A(e) OF THE INA SHALL BE GROUNDS FOR UNILATERAL CANCELLATION OF THE CONTRACT BY THE TOWN OF DUNDEE.**

BIDDER ATTESTS THAT THEY ARE FULLY COMPLIANT WITH ALL APPLICABLE IMMIGRATION LAWS (SPECIFICALLY TO THE 1986 IMMIGRATION ACT AND SUBSEQUENT AMENDMENTS).

Company Name JCR Construction & Services LLC

Signature [Signature] Date: 7/11/24

Printed Name Jarold Payan

Title President

PRIVATE PROVIDER FIRM _____

THIS SECTION TO BE COMPLETED BY A NOTARY PUBLIC:

STATE OF Florida COUNTY OF Polk

SWORN TO AND SUBSCRIBED BEFORE ME THIS 11 DAY OF July, 20 24

NOTARY PUBLIC: CHECK ONE PERSONALLY KNOWN TO ME Produced I.D. _____

TYPE OF ID PRODUCED _____

SIGN: Tammy Raulerson McCue

PRINT: Tammy Raulerson McCue



Tammy Raulerson McCue
Notary Public
State of Florida
Comm# HH434617
Expires 8/16/2027

NONCOLLUSION AFFIDAVIT OF BIDDER

State of Florida

County of Polk

I, Jarold Rayan ("Affiant"), being first duly sworn, deposes and says that:

- (1) Affiant is President (insert job title) of JCR Construction & Services LLC (insert name of company) the bidder that submitted the attached bid;
- (2) Affiant is fully informed respecting the preparation and contents of the attached bid and of all pertinent circumstances respecting such bid;
- (3) Such bid is genuine and is not a collusive or sham bid;
- (4) Neither the said Affiant nor any of his/her/its officers, partners, owners, agents, representatives, employees or parties in interest, including Affiant, has in any way colluded, conspired, connived or agreed, directly or indirectly with any other bidder, firm or person to submit a collusive or sham bid in connection with the Contract for which the attached bid has been submitted or has refrained from bidding in connection with such Contract; nor in any manner, directly or indirectly, sought by agreement or collusion or communication or conference with any other bidder, firm or person to fix the price or prices in the attached bid or of any other bidder; nor has fixed any overhead, profit or cost element of the bid price, or the bid price of any other bidder; nor has secured through any collusion, conspiracy, connivance or unlawful agreement, any advantage against the Town of Dundee or any person interested in the proposed Contract; and
- (5) The price or prices quoted in the attached bid are fair and proper and are not tainted by any collusion, conspiracy, connivance, or unlawful agreement on the part of the Affiant or any of its agents, representatives, owners, employees, or parties in interest.

THIS SECTION TO BE COMPLETED BY A NOTARY PUBLIC:

STATE OF Florida COUNTY OF Polk

SWORN TO AND SUBSCRIBED BEFORE ME THIS 11 DAY OF July, 2021

NOTARY PUBLIC: CHECK ONE PERSONALLY KNOWN TO ME Produced I.D. _____

TYPE OF ID PRODUCED _____

SIGN: Tammy Raulerson McCue

PRINT: Tammy Raulerson McCue



Tammy Raulerson McCue
Notary Public
State of Florida
Comm# HH434617
Expires 8/16/2027

CERTIFICATION OF DRUG-FREE WORKPLACE

Isaac Payan ("Undersigned"), certify that:

- (1) Undersigned is President (insert job title) and duly authorized to act on behalf of the Contractor JCR Construction & Services LLC that submitted the attached bid.
- (2) Undersigned acknowledges that Preference shall be given to businesses with drug-free workplace programs.
- (3) Undersigned acknowledges that whenever two (2) or more bids which are equal with respect to price, quality, and service are received by the Town for the Purchasing of commodities or contractual services, a bid received from a business that certifies that it has implemented a drug-free workplace program shall be given preference in the award process.
- (4) In order to have a drug-free workplace program, a business shall:
 - (a) Publish a statement notifying employees that the unlawful manufacture, distribution, dispensing, possession, or use of a controlled substance is prohibited in-the-workplace and specifying the actions that will be taken against employees for violations of such prohibition.
 - (b) Inform employees about the dangers of drug abuse in the workplace, the business's policy of maintaining a drug-free workplace, any available drug counseling, rehabilitation, and employee assistance programs, and the penalties that may be imposed upon employees for drug abuse violations.
 - (c) Give each employee engaged in providing the commodities or contractual services that are under bid a copy of the statement specified in subsection (a).
 - (d) In the statement specified in subsection (a), notify the employees that, as a condition of working on the commodities or contractual services that are under bid, the employee will abide by the terms of the statement and will notify the employer of any conviction of, or plea of guilty or nolo contendere to, any violation of Chapter 893 of the Florida Statutes or of any controlled substance law of the United States or any state, for a violation occurring in the workplace no later than five (5) days after such conviction.
 - (e) Impose a sanction on or require the satisfactory participation in a drug abuse assistance or rehabilitation program if such is available in the employee's community, by any employee who is so convicted.
 - (f) Make a good faith effort to continue to maintain a drug-free workplace through implementation of this section.

The Undersigned, as the person authorized to sign this CERTIFICATION OF DRUG FREE WORKPLACE, does hereby certify that the Contractor, JCL Construction & Services LLC, acknowledges, understands, and complies fully with the above requirements.

DATE: 7-11-24 NAME OF ENTITY: JCL Construction & Services LLC

PHONE/FAX: (863) 660-4704

ADDRESS: 3304 Block Pine Rd
Lakeland, FL 33810

SIGNATURE: 

PRINT NAME: Harold Payton

SALES TAX SAVINGS FORM

CONTRACT NUMBER: _____

NAME OF PROJECT: _____

MATERIALS	(1) Amount in Contract	(2) Sales Tax	(3) Net Amount

- (1) This is the amount to be deducted from contract by change order.
- (2) The amount of the sales tax included in the material purchase line item supplied by the Contractor.
- (3) The amount to be used by the Town to make the material purchase per the Contractor's stated quantities

CLIENT REFERENCES

CITY OF LAKELAND
LAKELAND LINDER INTERNATIONAL AIRPORT
3900 DON EMERSON DR SUITE 210
LAKELAND, FL 33813
03/2023 INTERIOR OFFICE REPAIRS 3240 FLIGHTLINE DR
BID # 3060
LINDA ALSBAUGH 863-834-6780
purch@lakeland.gov

POLK COUNTY BOARD OF COUNTY COMISSIONERS
330 WEST CHURCH ST
BARTOW, FL 33830
01/24 RENOVATION PHASE II RESTROOMS COURTHOUSE (in progress)
tabathashirah@polk-county.net

HARDEE COUNTY BOARD OF COUNTY COMMISSIONERS (in progress)
205 HANCHEY RD
WAUCHULA, FL
11/23 NEW BUILD AGRICULTURE EDUCATION CENTER
Carmen.soles@hardeecounty.net

CITY OF LAKE ALFRED
155 E POMELO
LAKE ALFRED, FL 33868
08/2023 MACKAY GARDENS & LAKESIDE PRESERVE BRICK PAVER PROJECT
JOHN DEATON 863-291-5270
jdeaton@mylakealfred.com



Ron DeSantis, Governor

Melanie S. Griffin, Secretary



**STATE OF FLORIDA
DEPARTMENT OF BUSINESS AND PROFESSIONAL REGULATION**

CONSTRUCTION INDUSTRY LICENSING BOARD

THE BUILDING CONTRACTOR HEREIN IS CERTIFIED UNDER THE
PROVISIONS OF CHAPTER 489, FLORIDA STATUTES

PAYAN, JAROLD

JCR CONSTRUCTION & SERVICES LLC
3804 BLOCK PRINE RD
LAKELAND FL 33810

LICENSE NUMBER: CBC1265799

EXPIRATION DATE: AUGUST 31, 2026

Always verify licenses online at MyFloridaLicense.com

ISSUED: 06/05/2024

Do not alter this document in any form.

This is your license. It is unlawful for anyone other than the licensee to use this document.



Request for Taxpayer Identification Number and Certification

Give Form to the requester. Do not send to the IRS.

Go to www.irs.gov/FormW9 for instructions and the latest information.

1 Name (as shown on your income tax return). Name is required on this line; do not leave this line blank.
JCR CONSTRUCTION & SERVICES LLC

2 Business name/disregarded entity name, if different from above

3 Check appropriate box for federal tax classification of the person whose name is entered on line 1. Check only one of the following seven boxes.

Individual/sole proprietor or single-member LLC C Corporation S Corporation Partnership Trust/estate

Limited liability company. Enter the tax classification (C=C corporation, S=S corporation, P=Partnership) ▶ _____
Note: Check the appropriate box in the line above for the tax classification of the single-member owner. Do not check another LLC if the LLC is classified as a single-member LLC that is disregarded from the owner unless the owner of the LLC is disregarded from the owner for U.S. federal tax purposes. Otherwise, a single-member LLC that is disregarded from the owner should check the appropriate box for the tax classification of its owner.

Other (see instructions) ▶ _____

4 Exemptions (codes apply only to certain entities, not individuals; see instructions on page 3):
Exempt payee code (if any) _____
Exemption from FATCA reporting code (if any) _____
(Applies to accounts maintained outside the U.S.)

5 Address (number, street, and apt. or suite no.) See instructions.
3804 BLOCK PRINE RD

6 City, state, and ZIP code
LAKELAND FL 33810

7 List account number(s) here (optional)

Requester's name and address (optional)

Print or type. See Specific Instructions on page 3.

Part I Taxpayer Identification Number (TIN)

Enter your TIN in the appropriate box. The TIN provided must match the name given on line 1 to avoid backup withholding. For individuals, this is generally your social security number (SSN). However, for a resident alien, sole proprietor, or disregarded entity, see the instructions for Part I, later. For other entities, it is your employer identification number (EIN). If you do not have a number, see *How to get a TIN*, later.

Note: If the account is in more than one name, see the instructions for line 1. Also see *What Name and Number To Give the Requester* for guidelines on whose number to enter.

Social security number									
			-						
OR									
Employer identification number									
4	6	-	4	8	4	3	0	0	3

Part II Certification

Under penalties of perjury, I certify that:

- The number shown on this form is my correct taxpayer identification number (or I am waiting for a number to be issued to me); and
- I am not subject to backup withholding because: (a) I am exempt from backup withholding, or (b) I have not been notified by the Internal Revenue Service (IRS) that I am subject to backup withholding as a result of a failure to report all interest or dividends, or (c) the IRS has notified me that I am no longer subject to backup withholding; and
- I am a U.S. citizen or other U.S. person (defined below); and
- The FATCA code(s) entered on this form (if any) indicating that I am exempt from FATCA reporting is correct.

Certification instructions. You must cross out item 2 above if you have been notified by the IRS that you are currently subject to backup withholding because you have failed to report all interest and dividends on your tax return. For real estate transactions, item 2 does not apply. For mortgage interest paid, acquisition or abandonment of secured property, cancellation of debt, contributions to an individual retirement arrangement (IRA), and generally, payments other than interest and dividends, you are not required to sign the certification, but you must provide your correct TIN. See the instructions for Part II, later.

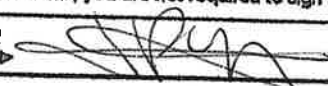
Sign Here Signature of U.S. person ▶  Date ▶ 7/25/24

General Instructions

Section references are to the Internal Revenue Code unless otherwise noted.

Future developments. For the latest information about developments related to Form W-9 and its instructions, such as legislation enacted after they were published, go to www.irs.gov/FormW9.

Purpose of Form

An individual or entity (Form W-9 requester) who is required to file an information return with the IRS must obtain your correct taxpayer identification number (TIN) which may be your social security number (SSN), individual taxpayer identification number (ITIN), adoption taxpayer identification number (ATIN), or employer identification number (EIN), to report on an information return the amount paid to you, or other amount reportable on an information return. Examples of information returns include, but are not limited to, the following:

- Form 1099-DIV (dividends, including those from stocks or mutual funds)
- Form 1099-MISC (various types of income, prizes, awards, or gross proceeds)
- Form 1099-B (stock or mutual fund sales and certain other transactions by brokers)
- Form 1099-S (proceeds from real estate transactions)
- Form 1099-K (merchant card and third party network transactions)
- Form 1098 (home mortgage interest), 1098-E (student loan interest), 1098-T (tuition)
- Form 1099-C (canceled debt)
- Form 1099-A (acquisition or abandonment of secured property)

Use Form W-9 only if you are a U.S. person (including a resident alien), to provide your correct TIN.

If you do not return Form W-9 to the requester with a TIN, you might be subject to backup withholding. See *What is backup withholding*, later.

POLK COUNTY LOCAL BUSINESS TAX RECEIPT

EXPIRES: 09/30/2024

CLASS: B+

ACCOUNT NO. 175316

LOCATION

**1508 STACY DR
LAKELAND**

OWNER NAME

JAROLD PAYAN

ACTIVITY TYPE

**CONTRACTOR BUILDING
CONTRACTOR BUILDING**

CODE

**230080
230080**

BUSINESS NAME AND MAILING ADDRESS

JCR CONSTRUCTION & SERVICES LLC

JCR CONSTRUCTION & SERVICES "LLC"

**1508 STACY DR
LAKELAND, FL 338012759**

**PROFESSIONAL LICENSE (IF APPLICABLE)
DBPR CBC1265799**

**THIS POLK COUNTY LOCAL BUSINESS TAX RECEIPT MUST BE CONSPICUOUSLY
DISPLAYED AT THE BUSINESS LOCATION**

OFFICE OF JOE G. TEDDER, CFC * TAX COLLECTOR

JCR CONSTRUCTION & SERVICES LLC

LSC 57.75

PAID - 1679768 08/02/2023 LCH



CERTIFICATE OF LIABILITY INSURANCE

DATE (MM/DD/YYYY)
04/01/2024

THIS CERTIFICATE IS ISSUED AS A MATTER OF INFORMATION ONLY AND CONFERS NO RIGHTS UPON THE CERTIFICATE HOLDER. THIS CERTIFICATE DOES NOT AFFIRMATIVELY OR NEGATIVELY AMEND, EXTEND OR ALTER THE COVERAGE AFFORDED BY THE POLICIES BELOW. THIS CERTIFICATE OF INSURANCE DOES NOT CONSTITUTE A CONTRACT BETWEEN THE ISSUING INSURER(S), AUTHORIZED REPRESENTATIVE OR PRODUCER, AND THE CERTIFICATE HOLDER.

IMPORTANT: If the certificate holder is an ADDITIONAL INSURED, the policy(ies) must have ADDITIONAL INSURED provisions or be endorsed. If SUBROGATION IS WAIVED, subject to the terms and conditions of the policy, certain policies may require an endorsement. A statement on this certificate does not confer rights to the certificate holder in lieu of such endorsement(s).

PRODUCER Next First Insurance Agency, Inc. PO Box 60787 Palo Alto, CA 94306	CONTACT NAME: PHONE (A/C, No, Ext): (855) 222-5919 FAX (A/C, No): E-MAIL ADDRESS: support@nextinsurance.com	
	INSURER(S) AFFORDING COVERAGE INSURER A : State National Insurance Company, Inc.	NAIC # 12831
INSURED JCR Construction & Services LLC 3804 Block Prine Rd Lakeland, FL 33810	INSURER B :	
	INSURER C :	
	INSURER D :	
	INSURER E :	
	INSURER F :	

COVERAGES **CERTIFICATE NUMBER:** 267122147 **REVISION NUMBER:**

THIS IS TO CERTIFY THAT THE POLICIES OF INSURANCE LISTED BELOW HAVE BEEN ISSUED TO THE INSURED NAMED ABOVE FOR THE POLICY PERIOD INDICATED. NOTWITHSTANDING ANY REQUIREMENT, TERM OR CONDITION OF ANY CONTRACT OR OTHER DOCUMENT WITH RESPECT TO WHICH THIS CERTIFICATE MAY BE ISSUED OR MAY PERTAIN, THE INSURANCE AFFORDED BY THE POLICIES DESCRIBED HEREIN IS SUBJECT TO ALL THE TERMS, EXCLUSIONS AND CONDITIONS OF SUCH POLICIES. LIMITS SHOWN MAY HAVE BEEN REDUCED BY PAID CLAIMS.

INSR LTR	TYPE OF INSURANCE	ADDL INSD	SUBR WVD	POLICY NUMBER	POLICY EFF (MM/DD/YYYY)	POLICY EXP (MM/DD/YYYY)	LIMITS
A	<input checked="" type="checkbox"/> COMMERCIAL GENERAL LIABILITY <input type="checkbox"/> CLAIMS-MADE <input checked="" type="checkbox"/> OCCUR GEN'L AGGREGATE LIMIT APPLIES PER: <input checked="" type="checkbox"/> POLICY <input type="checkbox"/> PRO-JECT <input type="checkbox"/> LOC OTHER:	X		NXT3J3FXLR-01-GL	05/27/2024	05/27/2025	EACH OCCURRENCE \$1,000,000.00
	DAMAGE TO RENTED PREMISES (Ea occurrence) \$100,000.00						
							MED EXP (Any one person) \$15,000.00
							PERSONAL & ADV INJURY \$1,000,000.00
							GENERAL AGGREGATE \$2,000,000.00
							PRODUCTS - COMP/OP AGG \$2,000,000.00
							\$
	AUTOMOBILE LIABILITY <input type="checkbox"/> ANY AUTO <input type="checkbox"/> OWNED AUTOS ONLY <input type="checkbox"/> SCHEDULED AUTOS <input type="checkbox"/> HIRED AUTOS ONLY <input type="checkbox"/> NON-OWNED AUTOS ONLY						COMBINED SINGLE LIMIT (Ea accident) \$
							BODILY INJURY (Per person) \$
							BODILY INJURY (Per accident) \$
							PROPERTY DAMAGE (Per accident) \$
							\$
	UMBRELLA LIAB <input type="checkbox"/> OCCUR EXCESS LIAB <input type="checkbox"/> CLAIMS-MADE DED RETENTION \$						EACH OCCURRENCE \$
							AGGREGATE \$
							\$
	WORKERS COMPENSATION AND EMPLOYERS' LIABILITY ANY PROPRIETOR/PARTNER/EXECUTIVE OFFICER/MEMBER EXCLUDED? (Mandatory In NH) If yes, describe under DESCRIPTION OF OPERATIONS below		Y/N	N/A			PER STATUTE OTH-ER
							E.L. EACH ACCIDENT \$
							E.L. DISEASE - EA EMPLOYEE \$
							E.L. DISEASE - POLICY LIMIT \$
A	Contractors Errors and Omissions	X		NXT3J3FXLR-01-GL	05/27/2024	05/27/2025	Each Occurrence: \$25,000.00 Aggregate: \$50,000.00

DESCRIPTION OF OPERATIONS / LOCATIONS / VEHICLES (ACORD 101, Additional Remarks Schedule, may be attached if more space is required)

The Certificate Holder is Town of Dundee. This Certificate Holder is an Additional Insured on the General Liability policy per the Additional Insured Automatic Status Endorsement. All Certificate Holder privileges apply only if required by written agreement between the Certificate Holder and the insured, and are subject to policy terms and conditions.

CERTIFICATE HOLDER Town of Dundee 202 E Main St Dundee, FL 33838	CANCELLATION SHOULD ANY OF THE ABOVE DESCRIBED POLICIES BE CANCELLED BEFORE THE EXPIRATION DATE THEREOF, NOTICE WILL BE DELIVERED IN ACCORDANCE WITH THE POLICY PROVISIONS. AUTHORIZED REPRESENTATIVE 
--	---

© 1988-2015 ACORD CORPORATION. All rights reserved.



CERTIFICATE OF LIABILITY INSURANCE

DATE (MM/DD/YYYY)
07/16/2024

THIS CERTIFICATE IS ISSUED AS A MATTER OF INFORMATION ONLY AND CONFERS NO RIGHTS UPON THE CERTIFICATE HOLDER. THIS CERTIFICATE DOES NOT AFFIRMATIVELY OR NEGATIVELY AMEND, EXTEND OR ALTER THE COVERAGE AFFORDED BY THE POLICIES BELOW. THIS CERTIFICATE OF INSURANCE DOES NOT CONSTITUTE A CONTRACT BETWEEN THE ISSUING INSURER(S), AUTHORIZED REPRESENTATIVE OR PRODUCER, AND THE CERTIFICATE HOLDER.

IMPORTANT: If the certificate holder is an ADDITIONAL INSURED, the policy(ies) must have ADDITIONAL INSURED provisions or be endorsed. If SUBROGATION IS WAIVED, subject to the terms and conditions of the policy, certain policies may require an endorsement. A statement on this certificate does not confer rights to the certificate holder in lieu of such endorsement(s).

PRODUCER Barfield Insurance & Financial Service 110 SPIRIT LAKE RD #5, WINTER HAVEN, FL 33880	CONTACT NAME: Progressive Commercial Lines Customer and Agent Servicing	
	PHONE (A/C, No, Ext): 1-800-444-4487	FAX (A/C, No):
	E-MAIL ADDRESS: progressivecommercial@email.progressive.com	
	INSURER(S) AFFORDING COVERAGE	
	INSURER A: Progressive Express Insurance Company	NAIC # 10193
	INSURED JCR CONSTRUCTION & SERVICES 1508 STACY DR LAKELAND, FL 33801	INSURER B: INSURER C: INSURER D: INSURER E: INSURER F:

COVERAGES

CERTIFICATE NUMBER: 765456938237345303D071624T200644

REVISION NUMBER:

THIS IS TO CERTIFY THAT THE POLICIES OF INSURANCE LISTED BELOW HAVE BEEN ISSUED TO THE INSURED NAMED ABOVE FOR THE POLICY PERIOD INDICATED. NOTWITHSTANDING ANY REQUIREMENT, TERM OR CONDITION OF ANY CONTRACT OR OTHER DOCUMENT WITH RESPECT TO WHICH THIS CERTIFICATE MAY BE ISSUED OR MAY PERTAIN, THE INSURANCE AFFORDED BY THE POLICIES DESCRIBED HEREIN IS SUBJECT TO ALL THE TERMS, EXCLUSIONS AND CONDITIONS OF SUCH POLICIES. LIMITS SHOWN MAY HAVE BEEN REDUCED BY PAID CLAIMS.

INSR LTR	TYPE OF INSURANCE	ADDL INSD	SUBR WVD	POLICY NUMBER	POLICY EFF (MM/DD/YYYY)	POLICY EXP (MM/DD/YYYY)	LIMITS
	COMMERCIAL GENERAL LIABILITY <input type="checkbox"/> CLAIMS-MADE <input type="checkbox"/> OCCUR GEN'L AGGREGATE LIMIT APPLIES PER: <input type="checkbox"/> POLICY <input type="checkbox"/> PRO-JECT <input type="checkbox"/> LOC OTHER:						EACH OCCURRENCE \$ DAMAGE TO RENTED PREMISES (Ea occurrence) \$ MED EXP (Any one person) \$ PERSONAL & ADV INJURY \$ GENERAL AGGREGATE \$ PRODUCTS - COMP/OP AGG \$ \$
A	AUTOMOBILE LIABILITY <input type="checkbox"/> ANY AUTO <input type="checkbox"/> OWNED AUTOS ONLY <input checked="" type="checkbox"/> SCHEDULED AUTOS <input checked="" type="checkbox"/> HIRED AUTOS ONLY <input checked="" type="checkbox"/> NON-OWNED AUTOS ONLY	Y	Y	01132238	10/01/2023	10/01/2024	COMBINED SINGLE LIMIT (Ea accident) \$1,000,000 BODILY INJURY (Per person) \$ BODILY INJURY (Per accident) \$ PROPERTY DAMAGE (Per accident) \$ \$
	UMBRELLA LIAB <input type="checkbox"/> OCCUR EXCESS LIAB <input type="checkbox"/> CLAIMS-MADE DED RETENTION \$						EACH OCCURRENCE \$ AGGREGATE \$ \$
	WORKERS COMPENSATION AND EMPLOYERS' LIABILITY <input type="checkbox"/> Y/N ANY PROPRIETOR/PARTNER/EXECUTIVE OFFICER/MEMBER EXCLUDED? (Mandatory in NH) If yes, describe under DESCRIPTION OF OPERATIONS below		N/A				<input type="checkbox"/> PER STATUTE <input type="checkbox"/> OTH-ER E.L. EACH ACCIDENT \$ E.L. DISEASE - EA EMPLOYEE \$ E.L. DISEASE - POLICY LIMIT \$
A	See ACORD 101 for additional coverage details.	Y	Y	01132238	10/01/2023	10/01/2024	\$

DESCRIPTION OF OPERATIONS / LOCATIONS / VEHICLES (ACORD 101, Additional Remarks Schedule, may be attached if more space is required)

CERTIFICATE HOLDER

CANCELLATION

TOWN OF DUNDEE 202 EAST MAIN ST DUNDEE, FL 33838	SHOULD ANY OF THE ABOVE DESCRIBED POLICIES BE CANCELLED BEFORE THE EXPIRATION DATE THEREOF, NOTICE WILL BE DELIVERED IN ACCORDANCE WITH THE POLICY PROVISIONS.
	AUTHORIZED REPRESENTATIVE 

© 1988-2015 ACORD CORPORATION. All rights reserved.



Company ID Number: 2151801



THE E-VERIFY MEMORANDUM OF UNDERSTANDING FOR EMPLOYERS

ARTICLE I PURPOSE AND AUTHORITY

The parties to this agreement are the Department of Homeland Security (DHS) and JCR CONSTRUCTION SERVICES LLC (Employer). The purpose of this agreement is to set forth terms and conditions which the Employer will follow while participating in E-Verify.

E-Verify is a program that electronically confirms an employee’s eligibility to work in the United States after completion of Form I-9, Employment Eligibility Verification (Form I-9). This Memorandum of Understanding (MOU) explains certain features of the E-Verify program and describes specific responsibilities of the Employer, the Social Security Administration (SSA), and DHS.

Authority for the E-Verify program is found in Title IV, Subtitle A, of the Illegal Immigration Reform and Immigrant Responsibility Act of 1996 (IIRIRA), Pub. L. 104-208, 110 Stat. 3009, as amended (8 U.S.C. § 1324a note). The Federal Acquisition Regulation (FAR) Subpart 22.18, “Employment Eligibility Verification” and Executive Order 12989, as amended, provide authority for Federal contractors and subcontractors (Federal contractor) to use E-Verify to verify the employment eligibility of certain employees working on Federal contracts.

ARTICLE II RESPONSIBILITIES

A. RESPONSIBILITIES OF THE EMPLOYER

1. The Employer agrees to display the following notices supplied by DHS in a prominent place that is clearly visible to prospective employees and all employees who are to be verified through the system:
 - a. Notice of E-Verify Participation
 - b. Notice of Right to Work
2. The Employer agrees to provide to the SSA and DHS the names, titles, addresses, and telephone numbers of the Employer representatives to be contacted about E-Verify. The Employer also agrees to keep such information current by providing updated information to SSA and DHS whenever the representatives’ contact information changes.
3. The Employer agrees to grant E-Verify access only to current employees who need E-Verify access. Employers must promptly terminate an employee’s E-Verify access if the employer is separated from the company or no longer needs access to E-Verify.



Company ID Number: 2151601

4. The Employer agrees to become familiar with and comply with the most recent version of the E-Verify User Manual.
 5. The Employer agrees that any Employer Representative who will create E-Verify cases will complete the E-Verify Tutorial before that individual creates any cases.
 - a. The Employer agrees that all Employer representatives will take the refresher tutorials when prompted by E-Verify in order to continue using E-Verify. Failure to complete a refresher tutorial will prevent the Employer Representative from continued use of E-Verify.
 6. The Employer agrees to comply with current Form I-9 procedures, with two exceptions:
 - a. If an employee presents a "List B" identity document, the Employer agrees to only accept "List B" documents that contain a photo. (List B documents identified in 8 C.F.R. § 274a.2(b)(1)(B)) can be presented during the Form I-9 process to establish identity.) If an employee objects to the photo requirement for religious reasons, the Employer should contact E-Verify at 888-464-4218.
 - b. If an employee presents a DHS Form I-551 (Permanent Resident Card), Form I-766 (Employment Authorization Document), or U.S. Passport or Passport Card to complete Form I-9, the Employer agrees to make a photocopy of the document and to retain the photocopy with the employee's Form I-9. The Employer will use the photocopy to verify the photo and to assist DHS with its review of photo mismatches that employees contest. DHS may in the future designate other documents that activate the photo screening tool.
- Note:** Subject only to the exceptions noted previously in this paragraph, employees still retain the right to present any List A, or List B and List C, document(s) to complete the Form I-9.
7. The Employer agrees to record the case verification number on the employee's Form I-9 or to print the screen containing the case verification number and attach it to the employee's Form I-9.
 8. The Employer agrees that, although it participates in E-Verify, the Employer has a responsibility to complete, retain, and make available for inspection Forms I-9 that relate to its employees, or from other requirements of applicable regulations or laws, including the obligation to comply with the anti-discrimination requirements of section 274B of the INA with respect to Form I-9 procedures.
 - a. The following modified requirements are the only exceptions to an Employer's obligation to not employ unauthorized workers and comply with the anti-discrimination provision of the INA: (1) List B identity documents must have photos, as described in paragraph 6 above; (2) When an Employer confirms the identity and employment eligibility of newly hired employee using E-Verify procedures, the Employer establishes a rebuttable presumption that it has not violated section 274A(a)(1)(A) of the Immigration and Nationality Act (INA) with respect to the hiring of that employee; (3) If the Employer receives a final nonconfirmation for an employee, but continues to employ that person, the Employer must notify DHS and the Employer is subject to a civil money penalty between \$550 and \$1,100 for each failure to notify DHS of continued employment following a final nonconfirmation; (4) If the Employer continues to employ an employee after receiving a final nonconfirmation, then the Employer is subject to a rebuttable presumption that it has knowingly



Company ID Number: 2151601

employed an unauthorized alien in violation of section 274A(a)(1)(A); and (5) no E-Verify participant is civilly or criminally liable under any law for any action taken in good faith based on information provided through the E-Verify.

b. DHS reserves the right to conduct Form I-9 compliance inspections, as well as any other enforcement or compliance activity authorized by law, including site visits, to ensure proper use of E-Verify.

9. The Employer is strictly prohibited from creating an E-Verify case before the employee has been hired, meaning that a firm offer of employment was extended and accepted and Form I-9 was completed. The Employer agrees to create an E-Verify case for new employees within three Employer business days after each employee has been hired (after both Sections 1 and 2 of Form I-9 have been completed), and to complete as many steps of the E-Verify process as are necessary according to the E-Verify User Manual. If E-Verify is temporarily unavailable, the three-day time period will be extended until it is again operational in order to accommodate the Employer's attempting, in good faith, to make inquiries during the period of unavailability.

10. The Employer agrees not to use E-Verify for pre-employment screening of job applicants, in support of any unlawful employment practice, or for any other use that this MOU or the E-Verify User Manual does not authorize.

11. The Employer must use E-Verify for all new employees. The Employer will not verify selectively and will not verify employees hired before the effective date of this MOU. Employers who are Federal contractors may qualify for exceptions to this requirement as described in Article II.B of this MOU.

12. The Employer agrees to follow appropriate procedures (see Article III below) regarding tentative nonconfirmations. The Employer must promptly notify employees in private of the finding and provide them with the notice and letter containing information specific to the employee's E-Verify case. The Employer agrees to provide both the English and the translated notice and letter for employees with limited English proficiency to employees. The Employer agrees to provide written referral instructions to employees and instruct affected employees to bring the English copy of the letter to the SSA. The Employer must allow employees to contest the finding, and not take adverse action against employees if they choose to contest the finding, while their case is still pending. Further, when employees contest a tentative nonconfirmation based upon a photo mismatch, the Employer must take additional steps (see Article III.B. below) to contact DHS with information necessary to resolve the challenge.

13. The Employer agrees not to take any adverse action against an employee based upon the employee's perceived employment eligibility status while SSA or DHS is processing the verification request unless the Employer obtains knowledge (as defined in 8 C.F.R. § 274a.1(l)) that the employee is not work authorized. The Employer understands that an initial inability of the SSA or DHS automated verification system to verify work authorization, a tentative nonconfirmation, a case in continuance (indicating the need for additional time for the government to resolve a case), or the finding of a photo mismatch, does not establish, and should not be interpreted as, evidence that the employee is not work authorized. In any of such cases, the employee must be provided a full and fair opportunity to contest the finding, and if he or she does so, the employee may not be terminated or suffer any adverse employment consequences based upon the employee's perceived employment eligibility status

Company ID Number: 2151601

(including denying, reducing, or extending work hours, delaying or preventing training, requiring an employee to work in poorer conditions, withholding pay, refusing to assign the employee to a Federal contract or other assignment, or otherwise assuming that he or she is unauthorized to work) until and unless secondary verification by SSA or DHS has been completed and a final nonconfirmation has been issued. If the employee does not choose to contest a tentative nonconfirmation or a photo mismatch or if a secondary verification is completed and a final nonconfirmation is issued, then the Employer can find the employee is not work authorized and terminate the employee's employment. Employers or employees with questions about a final nonconfirmation may call E-Verify at 1-888-464-4218 (customer service) or 1-888-897-7781 (worker hotline).

14. The Employer agrees to comply with Title VII of the Civil Rights Act of 1964 and section 274B of the INA as applicable by not discriminating unlawfully against any individual in hiring, firing, employment eligibility verification, or recruitment or referral practices because of his or her national origin or citizenship status, or by committing discriminatory documentary practices. The Employer understands that such illegal practices can include selective verification or use of E-Verify except as provided in part D below, or discharging or refusing to hire employees because they appear or sound "foreign" or have received tentative nonconfirmations. The Employer further understands that any violation of the immigration-related unfair employment practices provisions in section 274B of the INA could subject the Employer to civil penalties, back pay awards, and other sanctions, and violations of Title VII could subject the Employer to back pay awards, compensatory and punitive damages. Violations of either section 274B of the INA or Title VII may also lead to the termination of its participation in E-Verify. If the Employer has any questions relating to the anti-discrimination provision, it should contact OSC at 1-800-255-8155 or 1-800-237-2515 (TDD).

15. The Employer agrees that it will use the information it receives from E-Verify only to confirm the employment eligibility of employees as authorized by this MOU. The Employer agrees that it will safeguard this information, and means of access to it (such as PINS and passwords), to ensure that it is not used for any other purpose and as necessary to protect its confidentiality, including ensuring that it is not disseminated to any person other than employees of the Employer who are authorized to perform the Employer's responsibilities under this MOU, except for such dissemination as may be authorized in advance by SSA or DHS for legitimate purposes.

16. The Employer agrees to notify DHS immediately in the event of a breach of personal information. Breaches are defined as loss of control or unauthorized access to E-Verify personal data. All suspected or confirmed breaches should be reported by calling 1-888-464-4218 or via email at E-Verify@uscis.dhs.gov. Please use "Privacy Incident – Password" in the subject line of your email when sending a breach report to E-Verify.

17. The Employer acknowledges that the information it receives from SSA is governed by the Privacy Act (5 U.S.C. § 552a(i)(1) and (3)) and the Social Security Act (42 U.S.C. 1306(a)). Any person who obtains this information under false pretenses or uses it for any purpose other than as provided for in this MOU may be subject to criminal penalties.

18. The Employer agrees to cooperate with DHS and SSA in their compliance monitoring and evaluation of E-Verify, which includes permitting DHS, SSA, their contractors and other agents, upon



Company ID Number: 2151601

reasonable notice, to review Forms I-9 and other employment records and to interview it and its employees regarding the Employer's use of E-Verify, and to respond in a prompt and accurate manner to DHS requests for information relating to their participation in E-Verify.

19. The Employer shall not make any false or unauthorized claims or references about its participation in E-Verify on its website, in advertising materials, or other media. The Employer shall not describe its services as federally-approved, federally-certified, or federally-recognized, or use language with a similar intent on its website or other materials provided to the public. Entering into this MOU does not mean that E-Verify endorses or authorizes your E-Verify services and any claim to that effect is false.

20. The Employer shall not state in its website or other public documents that any language used therein has been provided or approved by DHS, USCIS or the Verification Division, without first obtaining the prior written consent of DHS.

21. The Employer agrees that E-Verify trademarks and logos may be used only under license by DHS/USCIS (see M-795 (Web)) and, other than pursuant to the specific terms of such license, may not be used in any manner that might imply that the Employer's services, products, websites, or publications are sponsored by, endorsed by, licensed by, or affiliated with DHS, USCIS, or E-Verify.

22. The Employer understands that if it uses E-Verify procedures for any purpose other than as authorized by this MOU, the Employer may be subject to appropriate legal action and termination of its participation in E-Verify according to this MOU.

B. RESPONSIBILITIES OF FEDERAL CONTRACTORS

1. If the Employer is a Federal contractor with the FAR E-Verify clause subject to the employment verification terms in Subpart 22.18 of the FAR, it will become familiar with and comply with the most current version of the E-Verify User Manual for Federal Contractors as well as the E-Verify Supplemental Guide for Federal Contractors.

2. In addition to the responsibilities of every employer outlined in this MOU, the Employer understands that if it is a Federal contractor subject to the employment verification terms in Subpart 22.18 of the FAR it must verify the employment eligibility of any "employee assigned to the contract" (as defined in FAR 22.1801). Once an employee has been verified through E-Verify by the Employer, the Employer may not create a second case for the employee through E-Verify.

a. An Employer that is not enrolled in E-Verify as a Federal contractor at the time of a contract award must enroll as a Federal contractor in the E-Verify program within 30 calendar days of contract award and, within 90 days of enrollment, begin to verify employment eligibility of new hires using E-Verify. The Employer must verify those employees who are working in the United States, whether or not they are assigned to the contract. Once the Employer begins verifying new hires, such verification of new hires must be initiated within three business days after the hire date. Once enrolled in E-Verify as a Federal contractor, the Employer must begin verification of employees assigned to the contract within 90 calendar days after the date of enrollment or within 30 days of an employee's assignment to the contract, whichever date is later.



Company ID Number: 2151601

b. Employers enrolled in E-Verify as a Federal contractor for 90 days or more at the time of a contract award must use E-Verify to begin verification of employment eligibility for new hires of the Employer who are working in the United States, whether or not assigned to the contract, within three business days after the date of hire. If the Employer is enrolled in E-Verify as a Federal contractor for 90 calendar days or less at the time of contract award, the Employer must, within 90 days of enrollment, begin to use E-Verify to initiate verification of new hires of the contractor who are working in the United States, whether or not assigned to the contract. Such verification of new hires must be initiated within three business days after the date of hire. An Employer enrolled as a Federal contractor in E-Verify must begin verification of each employee assigned to the contract within 90 calendar days after date of contract award or within 30 days after assignment to the contract, whichever is later.

c. Federal contractors that are institutions of higher education (as defined at 20 U.S.C. 1001(a)), state or local governments, governments of Federally recognized Indian tribes, or sureties performing under a takeover agreement entered into with a Federal agency under a performance bond may choose to only verify new and existing employees assigned to the Federal contract. Such Federal contractors may, however, elect to verify all new hires, and/or all existing employees hired after November 6, 1986. Employers in this category must begin verification of employees assigned to the contract within 90 calendar days after the date of enrollment or within 30 days of an employee's assignment to the contract, whichever date is later.

d. Upon enrollment, Employers who are Federal contractors may elect to verify employment eligibility of all existing employees working in the United States who were hired after November 6, 1986, instead of verifying only those employees assigned to a covered Federal contract. After enrollment, Employers must elect to verify existing staff following DHS procedures and begin

E-Verify verification of all existing employees within 180 days after the election.

e. The Employer may use a previously completed Form I-9 as the basis for creating an E-Verify case for an employee assigned to a contract as long as:

- i. That Form I-9 is complete (including the SSN) and complies with Article II.A.6,
- ii. The employee's work authorization has not expired, and
- iii. The Employer has reviewed the Form I-9 information either in person or in communications with the employee to ensure that the employee's Section 1, Form I-9 attestation has not changed (including, but not limited to, a lawful permanent resident alien having become a naturalized U.S. citizen).

f. The Employer shall complete a new Form I-9 consistent with Article II.A.6 or update the previous Form I-9 to provide the necessary information if:

- i. The Employer cannot determine that Form I-9 complies with Article II.A.6,
- ii. The employee's basis for work authorization as attested in Section 1 has expired or changed, or
- iii. The Form I-9 contains no SSN or is otherwise incomplete.

Note: If Section 1 of Form I-9 is otherwise valid and up-to-date and the form otherwise complies with



Company ID Number: 2151601

Article II.C.5, but reflects documentation (such as a U.S. passport or Form I-551) that expired after completing Form I-9, the Employer shall not require the production of additional documentation, or use the photo screening tool described in Article II.A.5, subject to any additional or superseding instructions that may be provided on this subject in the E-Verify User Manual.

g. The Employer agrees not to require a second verification using E-Verify of any assigned employee who has previously been verified as a newly hired employee under this MOU or to authorize verification of any existing employee by any Employer that is not a Federal contractor based on this Article.

3. The Employer understands that if it is a Federal contractor, its compliance with this MOU is a performance requirement under the terms of the Federal contract or subcontract, and the Employer consents to the release of information relating to compliance with its verification responsibilities under this MOU to contracting officers or other officials authorized to review the Employer's compliance with Federal contracting requirements.

C. RESPONSIBILITIES OF SSA

1. SSA agrees to allow DHS to compare data provided by the Employer against SSA's database. SSA sends DHS confirmation that the data sent either matches or does not match the information in SSA's database.
2. SSA agrees to safeguard the information the Employer provides through E-Verify procedures. SSA also agrees to limit access to such information, as is appropriate by law, to individuals responsible for the verification of Social Security numbers or responsible for evaluation of E-Verify or such other persons or entities who may be authorized by SSA as governed by the Privacy Act (5 U.S.C. § 552a), the Social Security Act (42 U.S.C. 1306(a)), and SSA regulations (20 CFR Part 401).
3. SSA agrees to provide case results from its database within three Federal Government work days of the initial inquiry. E-Verify provides the information to the Employer.
4. SSA agrees to update SSA records as necessary if the employee who contests the SSA tentative nonconfirmation visits an SSA field office and provides the required evidence. If the employee visits an SSA field office within the eight Federal Government work days from the date of referral to SSA, SSA agrees to update SSA records, if appropriate, within the eight-day period unless SSA determines that more than eight days may be necessary. In such cases, SSA will provide additional instructions to the employee. If the employee does not visit SSA in the time allowed, E-Verify may provide a final nonconfirmation to the employer.

Note: If an Employer experiences technical problems, or has a policy question, the employer should contact E-Verify at 1-888-464-4218.

D. RESPONSIBILITIES OF DHS

1. DHS agrees to provide the Employer with selected data from DHS databases to enable the Employer to conduct, to the extent authorized by this MOU:
 - a. Automated verification checks on alien employees by electronic means, and



Company ID Number: 2151601

- b. Photo verification checks (when available) on employees.
2. DHS agrees to assist the Employer with operational problems associated with the Employer's participation in E-Verify. DHS agrees to provide the Employer names, titles, addresses, and telephone numbers of DHS representatives to be contacted during the E-Verify process.
3. DHS agrees to provide to the Employer with access to E-Verify training materials as well as an E-Verify User Manual that contain instructions on E-Verify policies, procedures, and requirements for both SSA and DHS, including restrictions on the use of E-Verify.
4. DHS agrees to train Employers on all important changes made to E-Verify through the use of mandatory refresher tutorials and updates to the E-Verify User Manual. Even without changes to E-Verify, DHS reserves the right to require employers to take mandatory refresher tutorials.
5. DHS agrees to provide to the Employer a notice, which indicates the Employer's participation in E-Verify. DHS also agrees to provide to the Employer anti-discrimination notices issued by the Office of Special Counsel for Immigration-Related Unfair Employment Practices (OSC), Civil Rights Division, U.S. Department of Justice.
6. DHS agrees to issue each of the Employer's E-Verify users a unique user identification number and password that permits them to log in to E-Verify.
7. DHS agrees to safeguard the information the Employer provides, and to limit access to such information to individuals responsible for the verification process, for evaluation of E-Verify, or to such other persons or entities as may be authorized by applicable law. Information will be used only to verify the accuracy of Social Security numbers and employment eligibility, to enforce the INA and Federal criminal laws, and to administer Federal contracting requirements.
8. DHS agrees to provide a means of automated verification that provides (in conjunction with SSA verification procedures) confirmation or tentative nonconfirmation of employees' employment eligibility within three Federal Government work days of the initial inquiry.
9. DHS agrees to provide a means of secondary verification (including updating DHS records) for employees who contest DHS tentative nonconfirmations and photo mismatch tentative nonconfirmations. This provides final confirmation or nonconfirmation of the employees' employment eligibility within 10 Federal Government work days of the date of referral to DHS, unless DHS determines that more than 10 days may be necessary. In such cases, DHS will provide additional verification instructions.

ARTICLE III REFERRAL OF INDIVIDUALS TO SSA AND DHS

A. REFERRAL TO SSA

1. If the Employer receives a tentative nonconfirmation issued by SSA, the Employer must print the notice as directed by E-Verify. The Employer must promptly notify employees in private of the finding and provide them with the notice and letter containing information specific to the employee's E-Verify case.



Company ID Number: 2151601

The Employer also agrees to provide both the English and the translated notice and letter for employees with limited English proficiency to employees. The Employer agrees to provide written referral instructions to employees and instruct affected employees to bring the English copy of the letter to the SSA. The Employer must allow employees to contest the finding, and not take adverse action against employees if they choose to contest the finding, while their case is still pending.

2. The Employer agrees to obtain the employee's response about whether he or she will contest the tentative nonconfirmation as soon as possible after the Employer receives the tentative nonconfirmation. Only the employee may determine whether he or she will contest the tentative nonconfirmation.
3. After a tentative nonconfirmation, the Employer will refer employees to SSA field offices only as directed by E-Verify. The Employer must record the case verification number, review the employee information submitted to E-Verify to identify any errors, and find out whether the employee contests the tentative nonconfirmation. The Employer will transmit the Social Security number, or any other corrected employee information that SSA requests, to SSA for verification again if this review indicates a need to do so.
4. The Employer will instruct the employee to visit an SSA office within eight Federal Government work days. SSA will electronically transmit the result of the referral to the Employer within 10 Federal Government work days of the referral unless it determines that more than 10 days is necessary.
5. While waiting for case results, the Employer agrees to check the E-Verify system regularly for case updates.
6. The Employer agrees not to ask the employee to obtain a printout from the Social Security Administration number database (the Numident) or other written verification of the SSN from the SSA.

B. REFERRAL TO DHS

1. If the Employer receives a tentative nonconfirmation issued by DHS, the Employer must promptly notify employees in private of the finding and provide them with the notice and letter containing information specific to the employee's E-Verify case. The Employer also agrees to provide both the English and the translated notice and letter for employees with limited English proficiency to employees. The Employer must allow employees to contest the finding, and not take adverse action against employees if they choose to contest the finding, while their case is still pending.
2. The Employer agrees to obtain the employee's response about whether he or she will contest the tentative nonconfirmation as soon as possible after the Employer receives the tentative nonconfirmation. Only the employee may determine whether he or she will contest the tentative nonconfirmation.
3. The Employer agrees to refer individuals to DHS only when the employee chooses to contest a tentative nonconfirmation.
4. If the employee contests a tentative nonconfirmation issued by DHS, the Employer will instruct the



Company ID Number: 2151601

employee to contact DHS through its toll-free hotline (as found on the referral letter) within eight Federal Government work days.

5. If the Employer finds a photo mismatch, the Employer must provide the photo mismatch tentative nonconfirmation notice and follow the instructions outlined in paragraph 1 of this section for tentative nonconfirmations, generally.
6. The Employer agrees that if an employee contests a tentative nonconfirmation based upon a photo mismatch, the Employer will send a copy of the employee's Form I-551, Form I-766, U.S. Passport, or passport card to DHS for review by:
 - a. Scanning and uploading the document, or
 - b. Sending a photocopy of the document by express mail (furnished and paid for by the employer).
7. The Employer understands that if it cannot determine whether there is a photo match/mismatch, the Employer must forward the employee's documentation to DHS as described in the preceding paragraph. The Employer agrees to resolve the case as specified by the DHS representative who will determine the photo match or mismatch.
8. DHS will electronically transmit the result of the referral to the Employer within 10 Federal Government work days of the referral unless it determines that more than 10 days is necessary.
9. While waiting for case results, the Employer agrees to check the E-Verify system regularly for case updates.

ARTICLE IV SERVICE PROVISIONS

A. NO SERVICE FEES

1. SSA and DHS will not charge the Employer for verification services performed under this MOU. The Employer is responsible for providing equipment needed to make inquiries. To access E-Verify, an Employer will need a personal computer with Internet access.

ARTICLE V MODIFICATION AND TERMINATION

A. MODIFICATION

1. This MOU is effective upon the signature of all parties and shall continue in effect for as long as the SSA and DHS operates the E-Verify program unless modified in writing by the mutual consent of all parties.
2. Any and all E-Verify system enhancements by DHS or SSA, including but not limited to E-Verify checking against additional data sources and instituting new verification policies or procedures, will be covered under this MOU and will not cause the need for a supplemental MOU that outlines these changes.



Company ID Number: 2151601

B. TERMINATION

1. The Employer may terminate this MOU and its participation in E-Verify at any time upon 30 days prior written notice to the other parties.
2. Notwithstanding Article V, part A of this MOU, DHS may terminate this MOU, and thereby the Employer's participation in E-Verify, with or without notice at any time if deemed necessary because of the requirements of law or policy, or upon a determination by SSA or DHS that there has been a breach of system integrity or security by the Employer, or a failure on the part of the Employer to comply with established E-Verify procedures and/or legal requirements. The Employer understands that if it is a Federal contractor, termination of this MOU by any party for any reason may negatively affect the performance of its contractual responsibilities. Similarly, the Employer understands that if it is in a state where E-Verify is mandatory, termination of this by any party MOU may negatively affect the Employer's business.
3. An Employer that is a Federal contractor may terminate this MOU when the Federal contract that requires its participation in E-Verify is terminated or completed. In such cases, the Federal contractor must provide written notice to DHS. If an Employer that is a Federal contractor fails to provide such notice, then that Employer will remain an E-Verify participant, will remain bound by the terms of this MOU that apply to non-Federal contractor participants, and will be required to use the E-Verify procedures to verify the employment eligibility of all newly hired employees.
4. The Employer agrees that E-Verify is not liable for any losses, financial or otherwise, if the Employer is terminated from E-Verify.

ARTICLE VI PARTIES

- A. Some or all SSA and DHS responsibilities under this MOU may be performed by contractor(s), and SSA and DHS may adjust verification responsibilities between each other as necessary. By separate agreement with DHS, SSA has agreed to perform its responsibilities as described in this MOU.
- B. Nothing in this MOU is intended, or should be construed, to create any right or benefit, substantive or procedural, enforceable at law by any third party against the United States, its agencies, officers, or employees, or against the Employer, its agents, officers, or employees.
- C. The Employer may not assign, directly or indirectly, whether by operation of law, change of control or merger, all or any part of its rights or obligations under this MOU without the prior written consent of DHS, which consent shall not be unreasonably withheld or delayed. Any attempt to sublicense, assign, or transfer any of the rights, duties, or obligations herein is void.
- D. Each party shall be solely responsible for defending any claim or action against it arising out of or related to E-Verify or this MOU, whether civil or criminal, and for any liability wherefrom, including (but not limited to) any dispute between the Employer and any other person or entity regarding the applicability of Section 403(d) of IIRIRA to any action taken or allegedly taken by the Employer.



Company ID Number: 2151601

E. The Employer understands that its participation in E-Verify is not confidential information and may be disclosed as authorized or required by law and DHS or SSA policy, including but not limited to, Congressional oversight, E-Verify publicity and media inquiries, determinations of compliance with Federal contractual requirements, and responses to inquiries under the Freedom of Information Act (FOIA).

F. The individuals whose signatures appear below represent that they are authorized to enter into this MOU on behalf of the Employer and DHS respectively. The Employer understands that any inaccurate statement, representation, data or other information provided to DHS may subject the Employer, its subcontractors, its employees, or its representatives to: (1) prosecution for false statements pursuant to 18 U.S.C. 1001 and/or; (2) immediate termination of its MOU and/or; (3) possible debarment or suspension.

G. The foregoing constitutes the full agreement on this subject between DHS and the Employer.

To be accepted as an E-Verify participant, you should only sign the Employer's Section of the signature page. If you have any questions, contact E-Verify at 1-888-464-4218.



Company ID Number: 2151601

Approved by:

Employer JCR CONSTRUCTION SERVICES LLC	
Name (Please Type or Print) JAROLD PAYAN	Title
Signature Electronically Signed	Date 05/17/2023
Department of Homeland Security – Verification Division	
Name (Please Type or Print) USCIS Verification Division	Title
Signature Electronically Signed	Date 05/20/2023



Company ID Number: 2151601

Information Required for the E-Verify Program	
Information relating to your Company:	
Company Name	JCR CONSTRUCTION SERVICES LLC
Company Facility Address	3804 BLOCK PRINE ROAD LAKELAND, FL 33810
Company Alternate Address	
County or Parish	POLK
Employer Identification Number	464843003
North American Industry Classification Systems Code	236
Parent Company	
Number of Employees	5 to 9
Number of Sites Verified for	1 site(s)



Company ID Number: 2151601



Are you verifying for more than 1 site? If yes, please provide the number of sites verified for in each State:

FL 1



Company ID Number: 2151601

Information relating to the Program Administrator(s) for your Company on policy questions or operational problems:

Name JAROLD PAYAN
Phone Number 8636604704
Fax
Email icrconstructionservices@gmail.com

Name Tammy L McCue
Phone Number 8635955533
Fax
Email tammvmccue@gmail.com



Company ID Number: 2151601



This list represents the first 20 Program Administrators listed for this company.

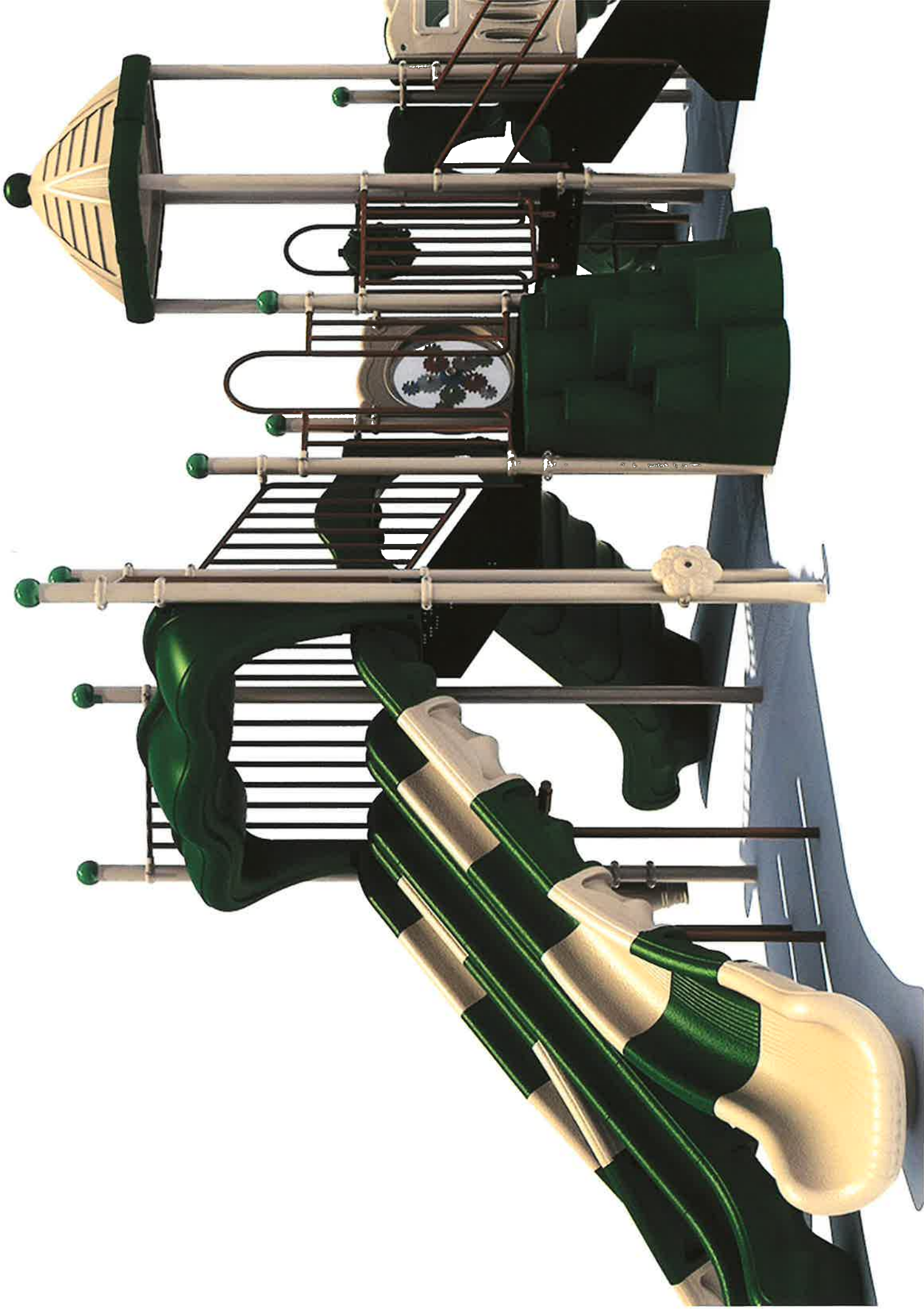

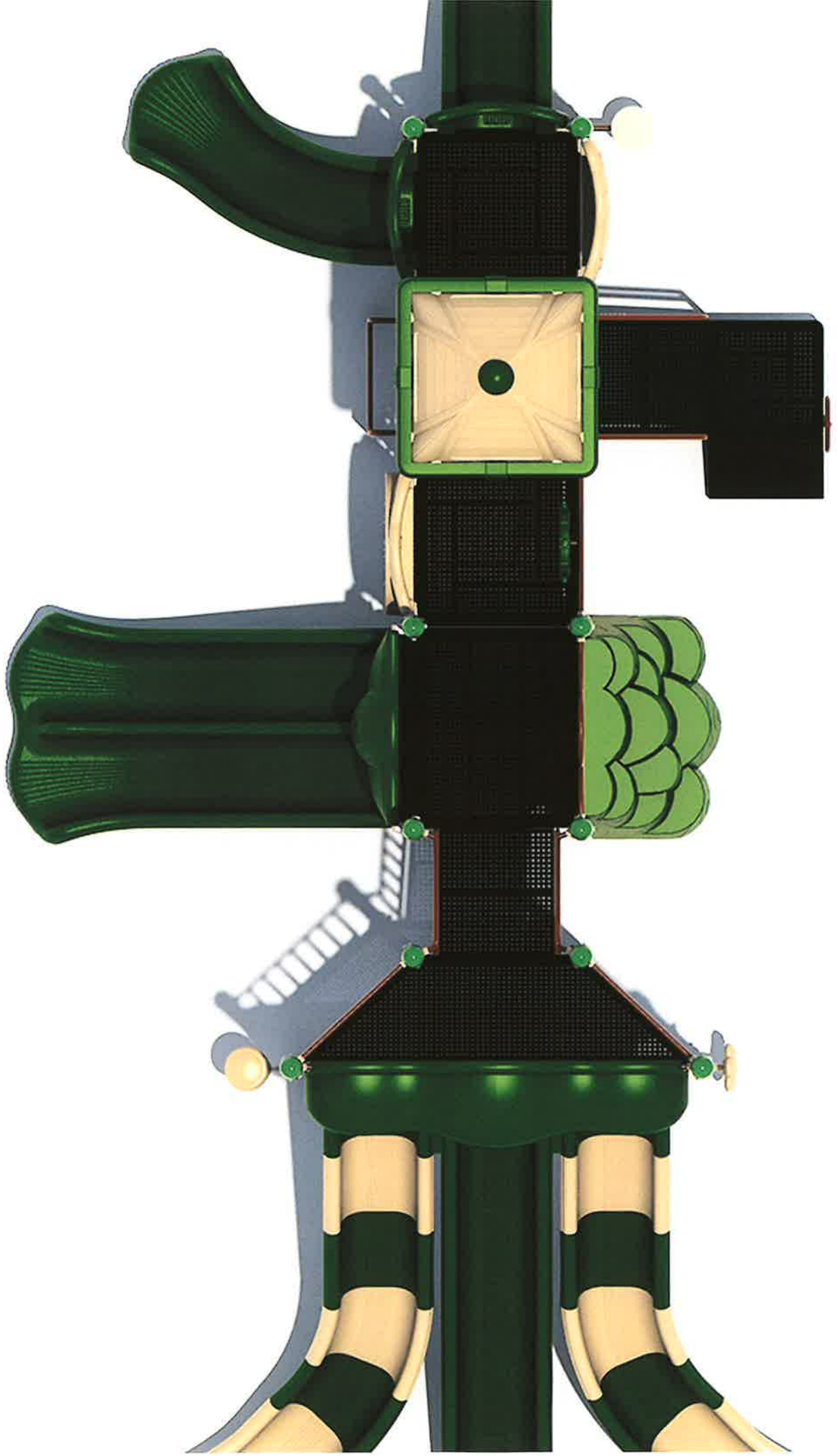



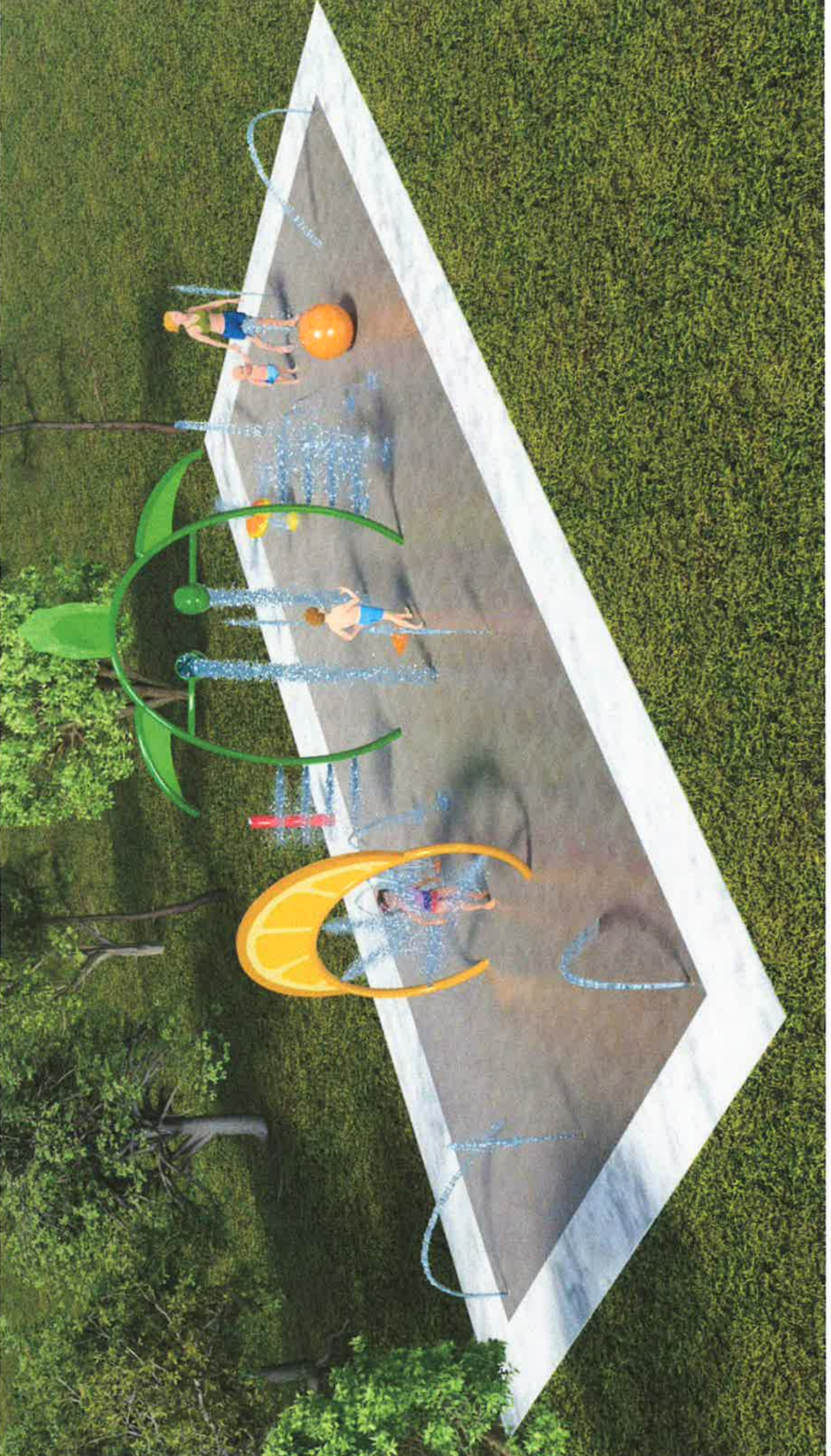

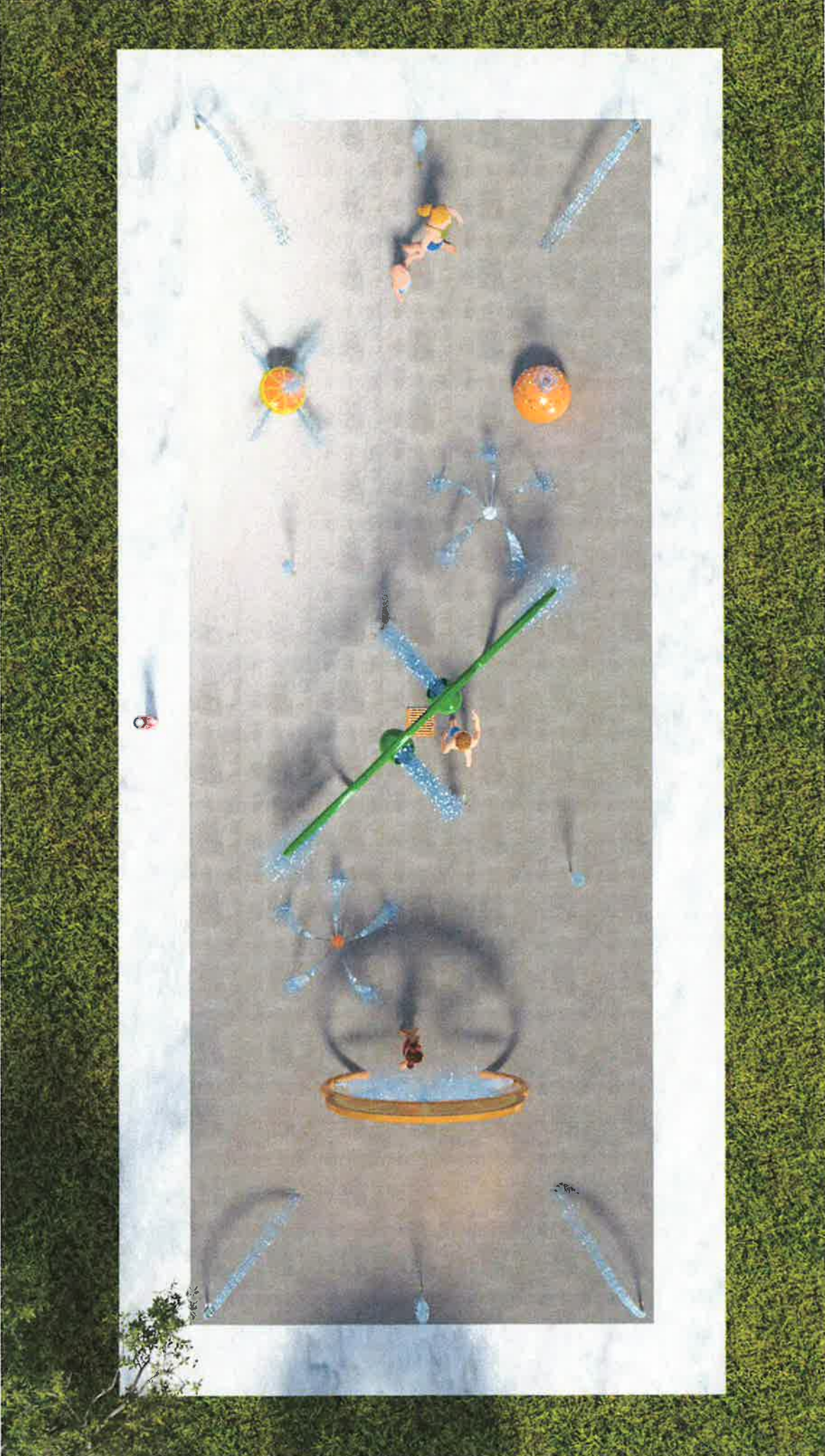





2024-5740-1

Florida - Town of Dundee Splash Pad



WATER SPLASH PROJECT PROPOSAL

About Water Splash, Inc.



Water Splash, Inc. is an innovative water playground equipment manufacturer founded in 2003 by a team of engineers who put their skills at the heart of their enterprise, with an emphasis on continuous product improvement through research and development. Our team has a total of 15 years experience in the design and manufacture of splash park equipment. We provide products for splash pads, spray parks/spray grounds and swimming pools. We have a strong engineering and customer care group that will provide the technical support you need at every stage of your project. Our durable and reliable products come with timely and personalized customer service, and they're factory assembled and tested to reduce your installation costs. Backed by some of the strongest product warranties in the industry and an unparalleled safety record, Water Splash is rapidly becoming the benchmark for top quality splash pad products.

Key Personnel

CEO & Project Manager - Gokhan CELIK / gcelik@watersplashnet.com

Co-Partner & Director of Sales-Design - Zafer INANC / zinanc@watersplashnet.com

Engineering Manager - Esad YAVUZ / eyavuz@watersplashnet.com

Production & Planning Manager - Veysel RENCBER / vrencber@watersplashnet.com

Construction Manager - Milan PETROVA / mpetrova@watersplashnet.com

Aquatic & Mechanical Engineer - Mehdi MOUSAVI / mmousavi@watersplashnet.com

Sales Specialist - Serap ACAR / sacar@watersplashnet.com

Customer Service & Accounting - Maya PETROVA / mpetrova@watersplashnet.com

Our project team has decades of experience in designing, manufacturing, and building spray parks and aquatic facilities, moreover we will continue to design and construct with a Safety First emphasis for this project. Information on our teams experience with Safety and Management is included in the appendix A. A preliminary safety plan can be submitted upon request.

We look forward to working with you.

Gokhan Celik
Water Splash,
gcelik@watersplashnet.com
(800) 936-3430



Water Splash offers its expertise in splash park design, manufacturing and installation for your project. Our approach is to work with customer directly and get customer's input for each stage of the project. Therefore, within the first week of project approval, we schedule an online meeting with customer's representatives and our project manager. The goal of this meeting is:

- * Identify if there is any changes on proposed splash park layout,
- * Finalize product list and colors for splash park, List each departments and contacts for
- * Construction Permit / If Required *Plumbing /Water Permit -Approval / If Required Electrical connection details / Permit if needed

Second stage is our production stage which is around 6-7 weeks. Between production completion and construction start, we will setup an onsite meeting with customer's representative to review final construction plans along with permit application status. After production is completed, our project manager will be onsite to receive all parts and start excavation, setting up anchor bases, placing and leveling products, grounding each product to mechanical room, plumbing each product to manifold lines, backfilling and surface concrete pouring. We will have pressure testing of plumbing connections before concrete is poured in order to make sure pipes withstand working pressure of Splash Park.

Last item is to commission Splash Park to owner by training customer's representative for daily day usage, and maintenance procedures.

Wishing to be a solution partner for your project.



Water Splash Engineering

Water Splash products are designed and manufactured to meet two basic criteria; fun and safety. Only the finest materials are used in the construction process, to ensure that maximum safeguards are incorporated into every design.



To this end, all manufacturing and tooling takes place in-house, and all products conform to or exceed ASTM F1487, ASTM F2461, SS457 and CSA Z614-07 standards.

Our in-house engineering and manufacturing expertise also provide our customers with another advantage: complete customization, to suit any and all of their needs.



WATER SPLASH

www.watersplashnet.com
(800) 936-3430

Thank You

To: Splash Park Evaluation Committee,

Thank you for the opportunity given to submit Water Splash, Inc's unique splash park layout proposal for your community. Water Splash has over 15 years experience in designing, building and installing splash parks throughout the US, Canada, Europe and many other countries. We create your unique splash park design by considering: safety, play value, budget and aesthetics.

Our products are made of durable stainless steel material, which meet or exceed all requirements.

ASTM F-1487, ASTM F2461 (USA)

CSA Z-614-07 (CANADA)

EN 1176 (EU)

AS685 (AU) Electrical Components

European Union directives and standards

We look forward to discussing our proposal with you, ensuring all the special requirements within your community are met beyond satisfaction.

We appreciate your consideration and will always go that extra mile to earn your business.

Kind regards,

Gokhan CELIK

Water Splash

gcelik@watersplashnet.com

(800) 936 - 3430



PRODUCT LIST

NO	PRODUCT CODE	PRODUCT NAME	QTY	FOOTING TYPE
1	S-06.01	SEA TURTLE	1	-A-
2	S-03.02.34	ORANGE LOOP	1	-A-
3	S-02.09.01	AQUA SPHERE(24)	1	Surface
4	S-02.77	AQUA ORANGE	1	-A-
5	S-05.06.01	AQUA GEYSER	2	-C-
6	S-05.01.04	AQUA JET VERTICAL	4	-D-
7	S-05.01	AQUA JET	4	-D-
8	S-20.14	AUDIBLE ACTIVATOR	1	Surface
9	S-16.01	DRAIN BOX	1	-
TOTAL			16	

TODDLER

BIG KID

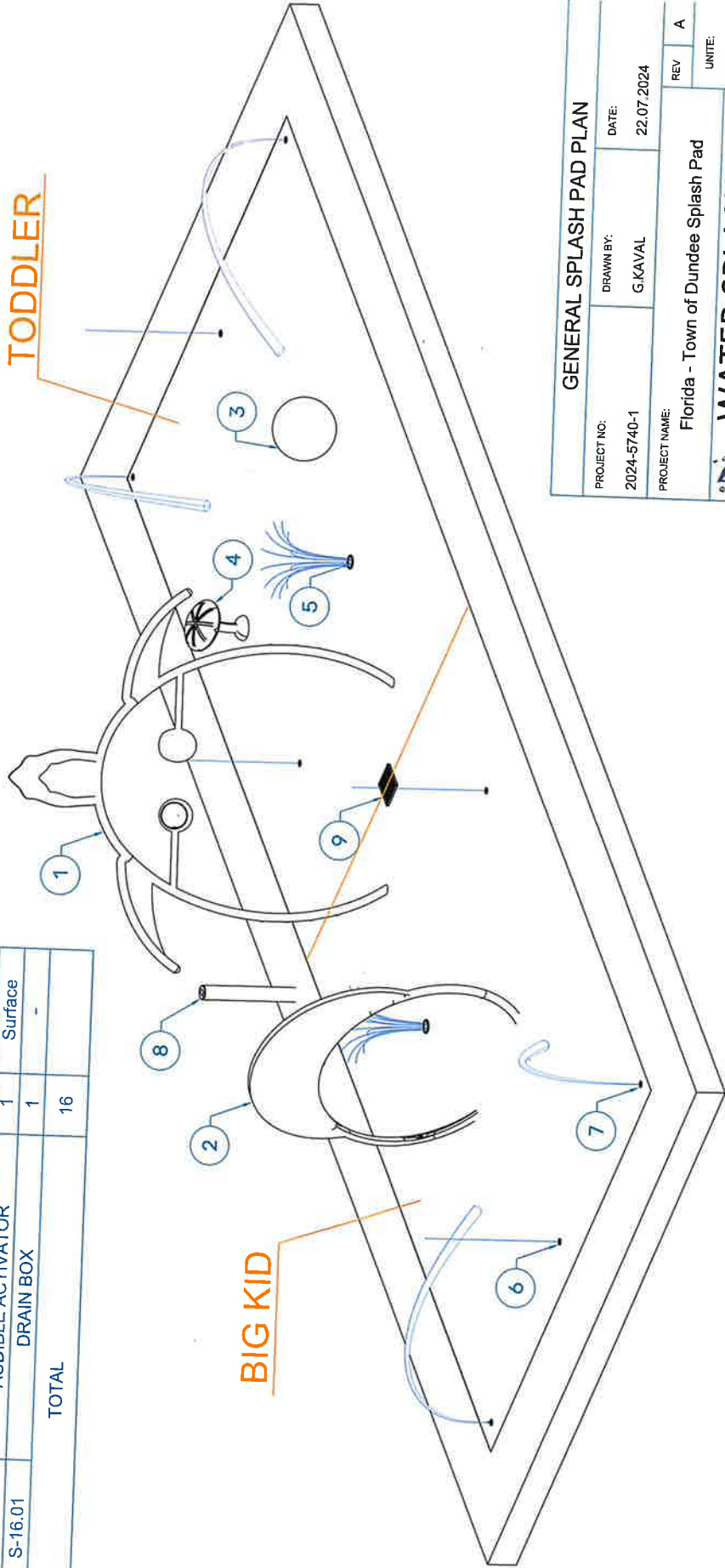

GENERAL SPLASH PAD PLAN		REV	A
PROJECT NO: 2024-5740-1	DRAWN BY: G.KAVAL	DATE: 22.07.2024	UNITE: FT-INCH
PROJECT NAME: Florida - Town of Dundee Splash Pad		SHEET: A	
 WATER SPLASH INC. <small>THIS DRAWING IS A PROPERTY OF WATER SPLASH INC. AND IS NOT TO BE REPRODUCED BY ANY MEANS OR USED TO FURNISH INFORMATION TO ANY OTHER PARTY WITHOUT THE EXPRESS CONSENT OF WATER SPLASH INC.</small>			

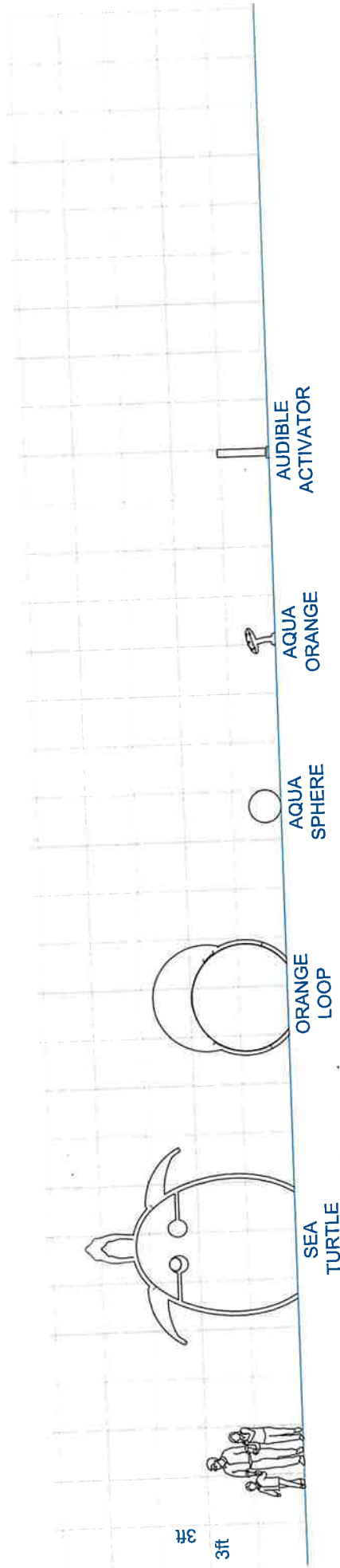

Total Area With 5' Dry Zone 1000 sqft (93m²)

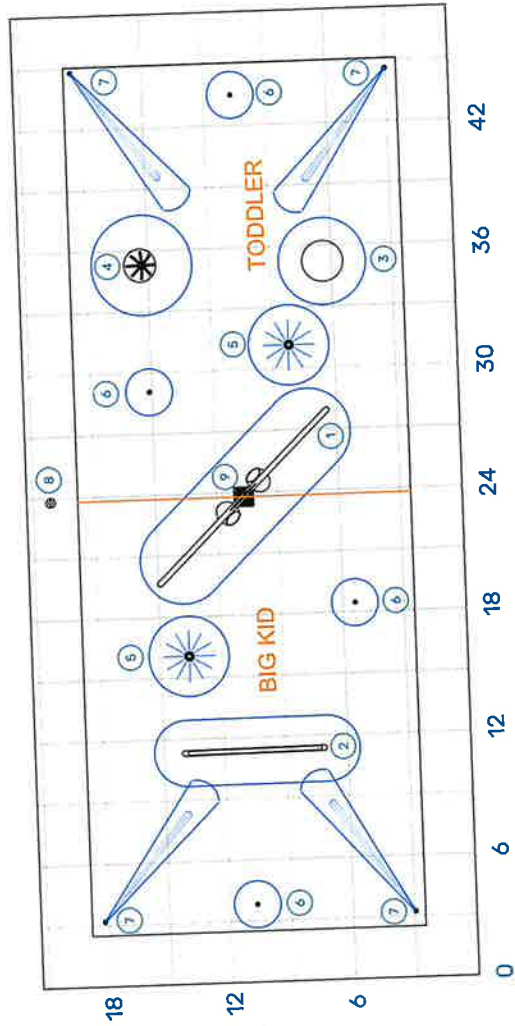

PRODUCT LIST			
NO	PRODUCT CODE	PRODUCT NAME	FOOTING TYPE
1	S-06.01	SEA TURTLE	-A-
2	S-03.02.34	ORANGE LOOP	-A-
3	S-02.09.01	AQUA SPHERE(24)	Surface
4	S-02.77	AQUA ORANGE	-A-
5	S-05.06.01	AQUA GEYSER	-C-
6	S-05.01.04	AQUA JET VERTICAL	-D-
7	S-05.01	AQUA JET	-D-
8	S-20.14	AUDIBLE ACTIVATOR	Surface
9	S-16.01	DRAIN BOX	-
TOTAL		16	

GENERAL SPLASH PAD PLAN

PROJECT NO: 2024-5740-1 DRAWN BY: G.KAVAL DATE: 22.07.2024

PROJECT NAME: Florida - Town of Dundee Splash Pad

REV: A UNIT: FT-INCH SHEET:

WATER SPLASH INC.
THIS DRAWING IS A PROPERTY OF WATER SPLASH INC. AND IS NOT TO BE REPRODUCED OR COPIED IN ANY MANNER WITHOUT THE EXPRESS WRITTEN CONSENT OF WATER SPLASH INC.

PRODUCT LIST				
NO	PRODUCT CODE	PRODUCT NAME	QTY	TOTAL GPM
1	S-06.01	SEA TURTLE	1	10
2	S-03.02.34	ORANGE LOOP	1	10
3	S-02.09.01	AQUA SPHERE(24)	1	5
4	S-02.77	AQUA ORANGE	1	7
5	S-05.06.01	AQUA GEYSER	2	5
6	S-05.01.04	AQUA JET VERTICAL	4	3
7	S-05.01	AQUA JET	4	3
TOTAL			66	

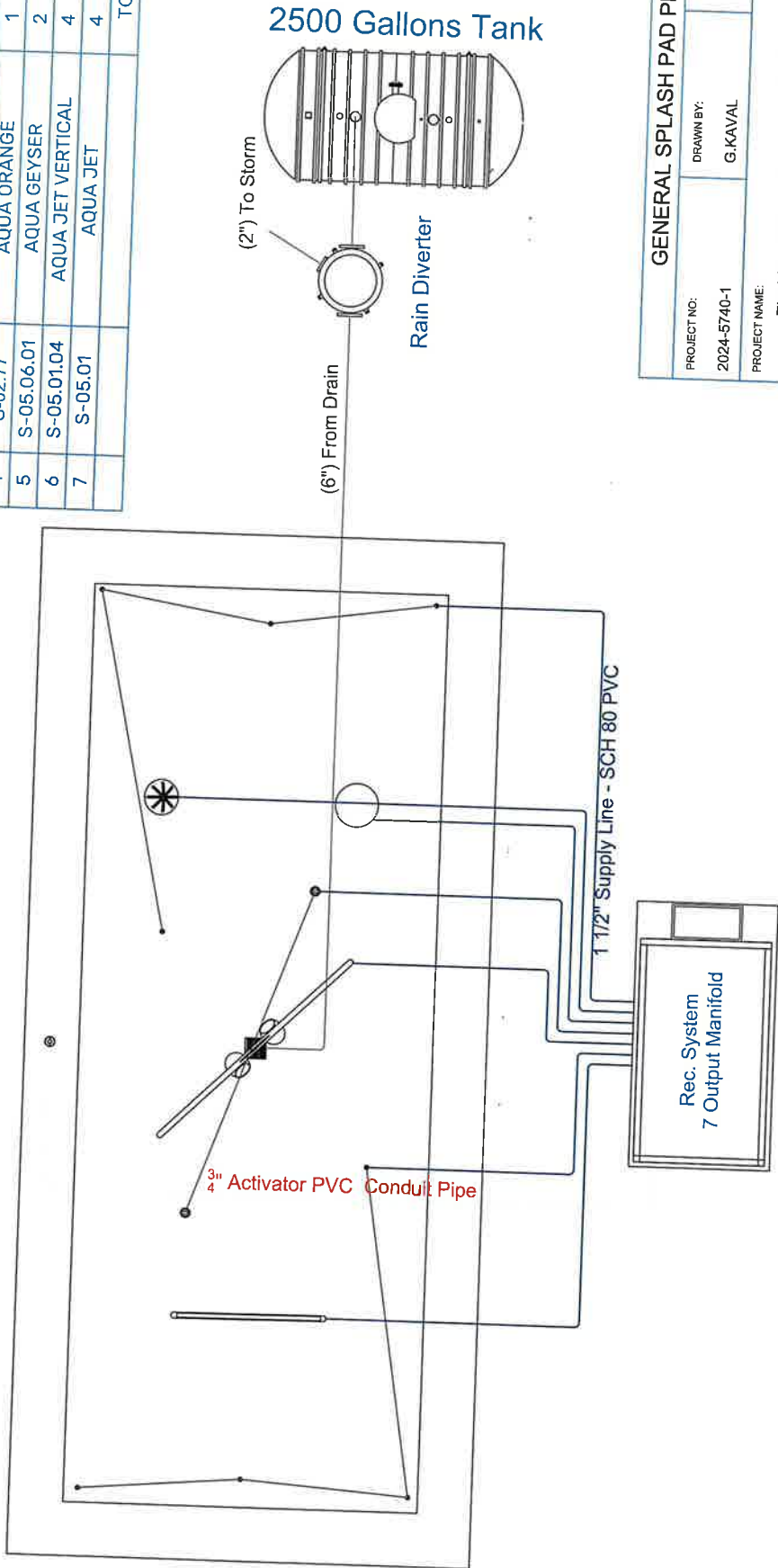

GENERAL SPLASH PAD PLAN

PROJECT NO: 2024-5740-1 DRAWN BY: G.KAVAL DATE: 22.07.2024

PROJECT NAME: Florida - Town of Dundee Splash Pad REV: A

WATER SPLASH INC.
THIS DRAWING IS A PROPERTY OF WATER SPLASH INC. IT IS NOT TO BE REPRODUCED BY ANY MEANS OR USED TO FURNISH INFORMATION TO OTHERS WITHOUT THE EXPRESS CONSENT OF WATER SPLASH INC.

UNITE: FT-INCH SHEET:

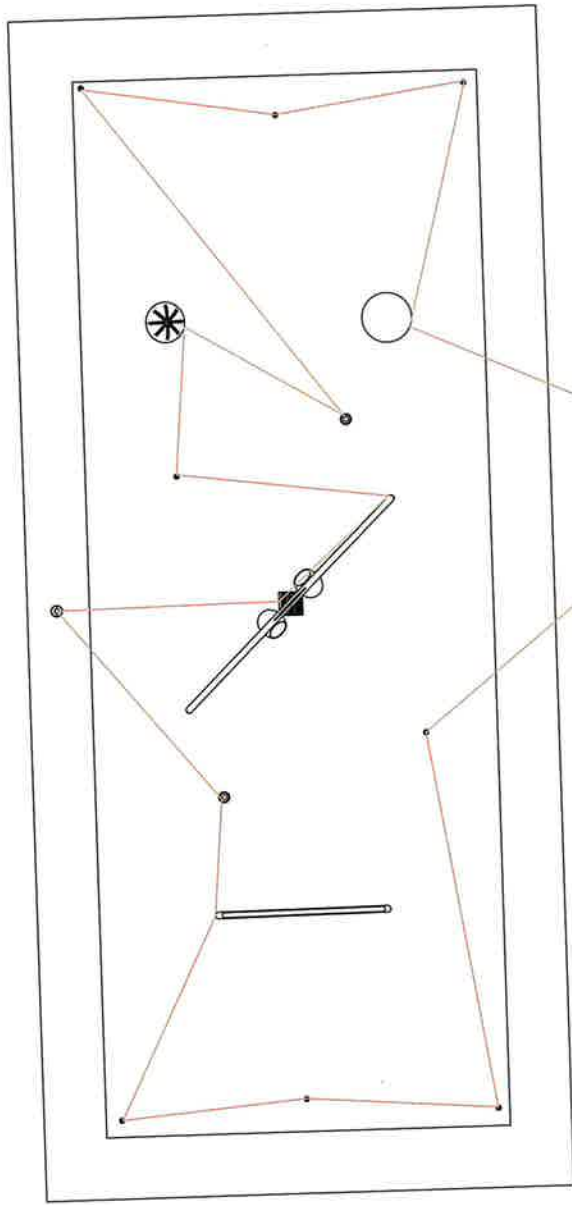

2500 Gallons Tank

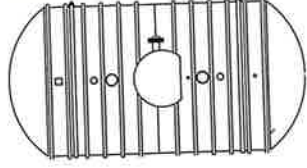

Rain Diverter

GENERAL SPLASH PAD PLAN			
PROJECT NO: 2024-5740-1	DRAWN BY: G.KAVVAL	DATE: 22.07.2024	REV: A
PROJECT NAME: Florida - Town of Dundee Splash Pad		UNITE: FT-INCH	SHEET:
 WATER SPLASH INC. <small>THIS DRAWING IS A PROPERTY OF WATER SPLASH INC. AND IS NOT TO BE REPRODUCED OR COPIED IN ANY MANNER WITHOUT THE EXPRESS CONSENT OF WATER SPLASH.</small>			

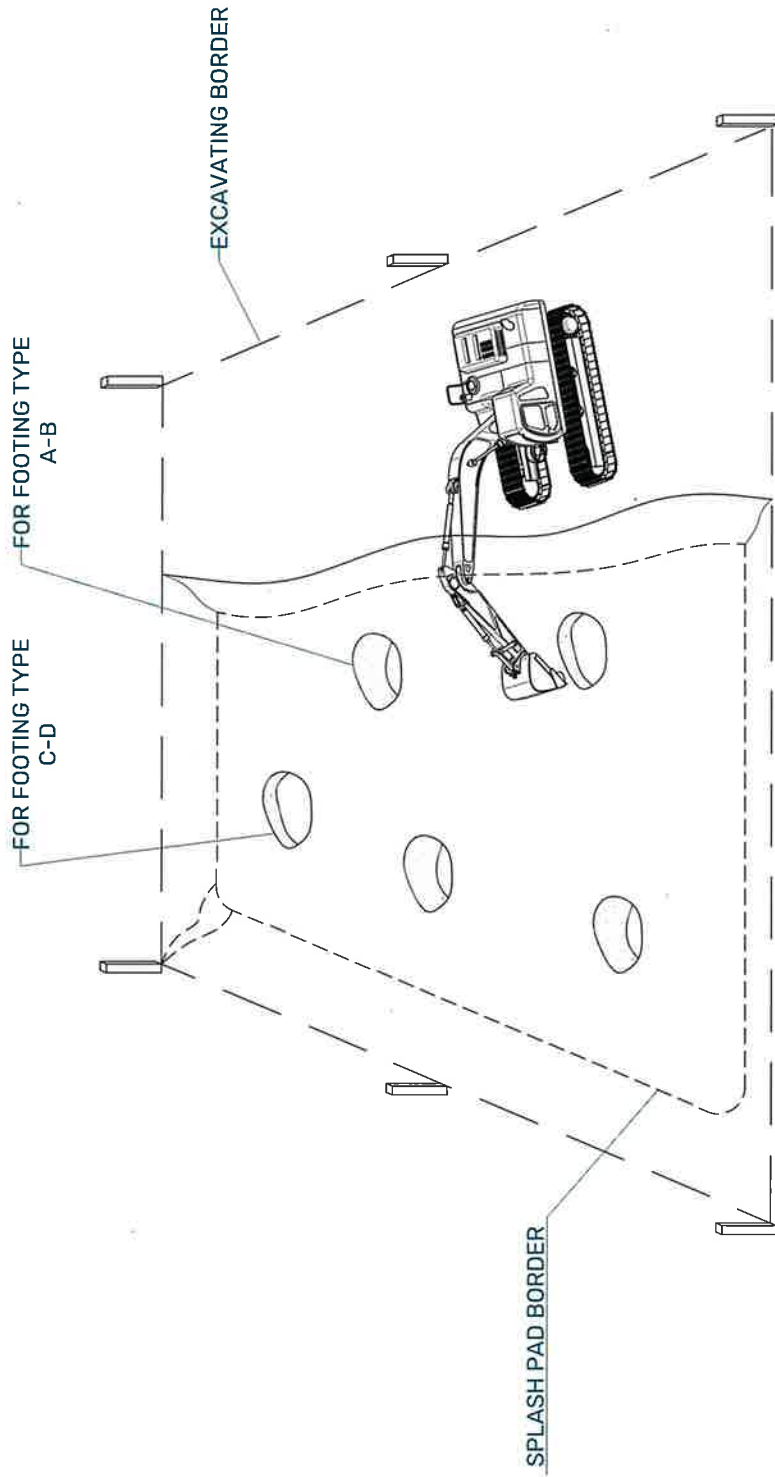

Florida - Town of Dundee Splash Pad Product: Concrete	Approx. Amount: 1.2 m ³ 1.5 yard ³
--	--

GENERAL SPLASH PAD EXCAVATION	
PROJECT NO: 2024-5740-1	DATE: 22.07.2024
DRAWN BY: G.KAVAL	
PROJECT NAME: Florida - Town of Dundee Splash Pad	
REV A	UNITE: FT-INCH
SHEET: SHEET:	

WATER SPLASH INC.
 THIS DRAWING IS A PROPERTY OF WATER SPLASH INC. AND IS NOT TO BE REPRODUCED BY ANY MEANS OR USED TO FURNISH INFORMATION TO OTHERS WITHOUT THE EXPLICIT CONSENT OF WATER SPLASH

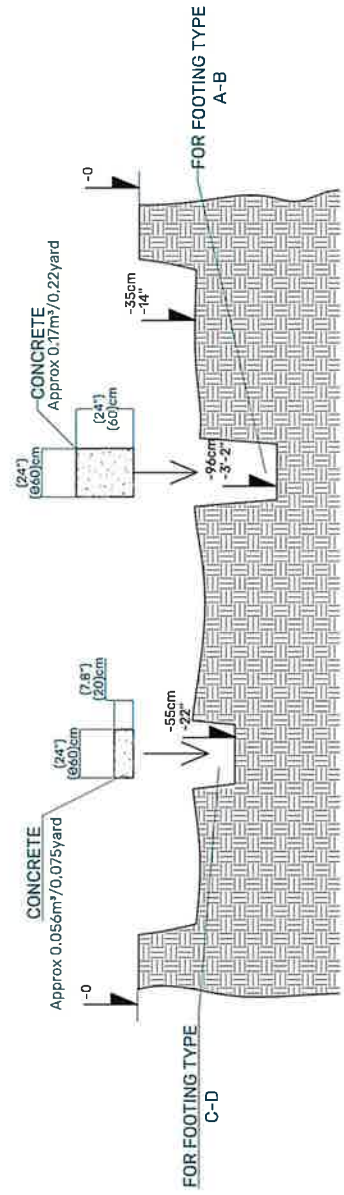

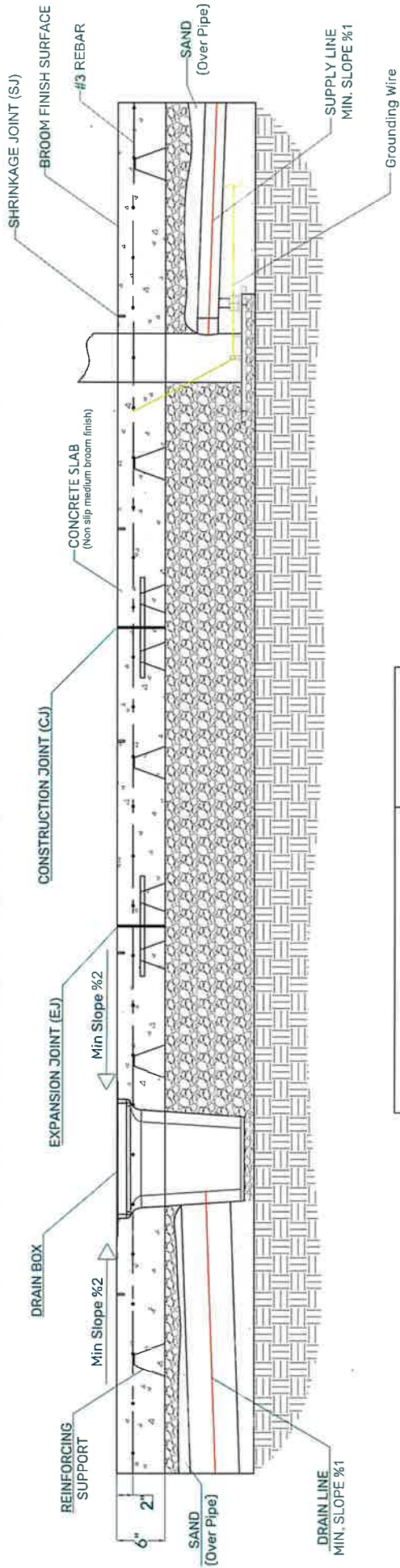

Florida - Town of Dundee Splash Pad
Total Area 1000 sqft (93m²)

	Approx. Amount
SURFACE CONCRETE	13.95 m ³ 18.2 yard ³
COMPACTED GRAVEL AND SAND	16.2 m ³ 21.1 yard ³

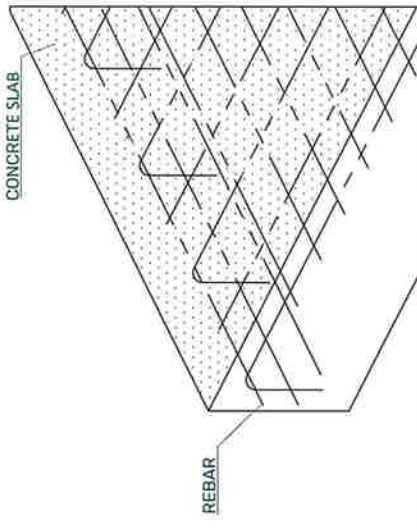

TYPICAL CONCRETE BASE END CROSSECTION

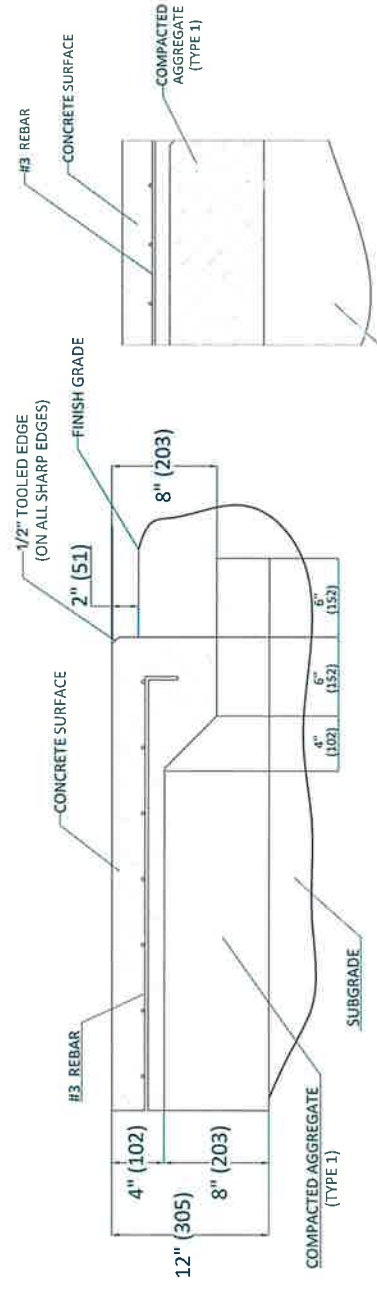

GENERAL SPLASH PAD CONCRETE DETAIL

PROJECT NO: 2024-5740-1
DRAWN BY: G.KAVAL
DATE: 22.07.2024

PROJECT NAME: Florida - Town of Dundee Splash Pad

REV: A
UNITE: FT-INCH
SHEET:

WATER SPLASH INC.
THE ONLY WATER SPLASHING CONTRACTOR IN FLORIDA
ANY MEANS OR USED TO FURNISH INFORMATION TO OTHERS WITHOUT THE EXPRESS
CONSENT OF WATER SPLASH

FOOTING DETAIL TYPE-A

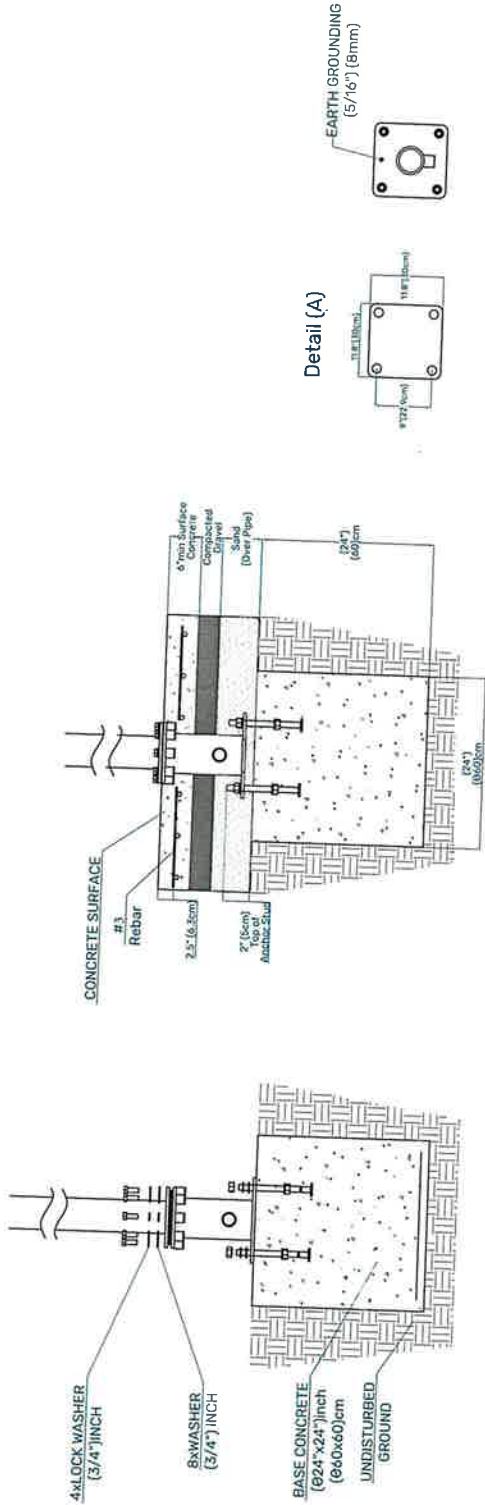

FOOTING DETAIL TYPE-B

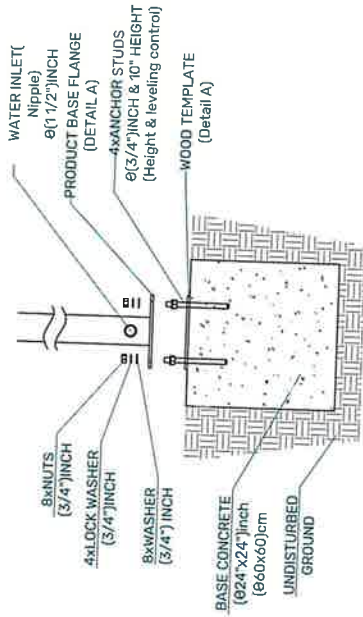

1- Fix anchor studs along with wood template while concrete is wet as shown.

FOOTING DETAILS

PROJECT NO:	2024-5740-1	DRAWN BY:	G.KAVAL	DATE:	22.07.2024
PROJECT NAME:	Florida - Town of Dundee Splash Pad				

REV	A
UNIT:	Inch cm
SHEET:	

WATER SPLASH INC.
 THIS DRAWING IS A PROPERTY OF WATER SPLASH INC. AND IS NOT TO BE REPRODUCED BY ANY MEANS OR USED TO PROMOTE OR DISCREDIT WATER SPLASH INC. WITHOUT THE EXPLICIT CONSENT OF WATER SPLASH INC.

FOOTING DETAIL TYPE-C

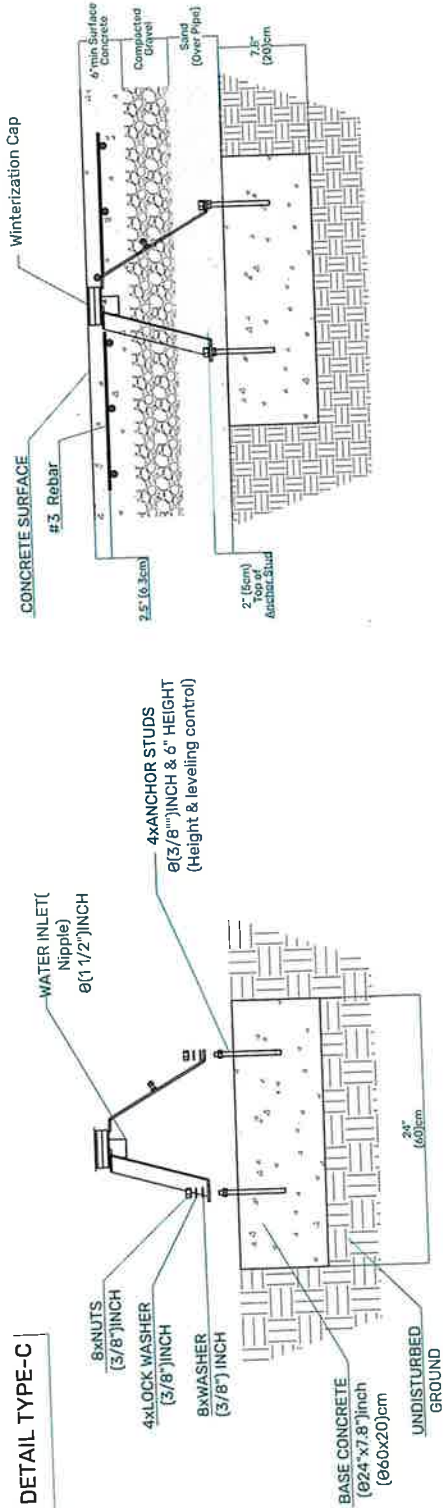

FOOTING DETAIL TYPE-D

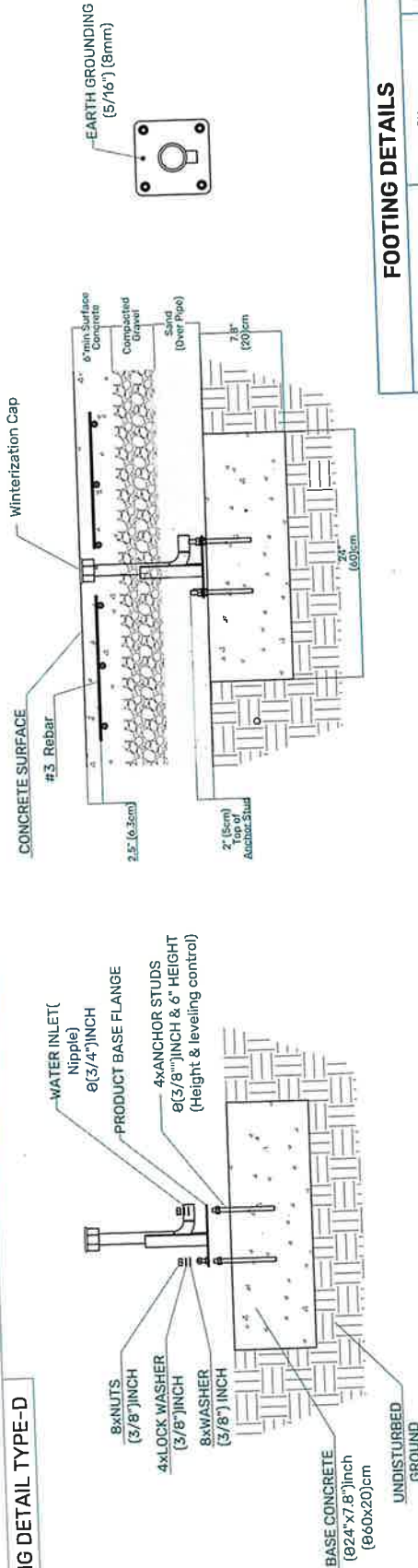

1- Anchors to be drilled after concrete poured. (Use epoxy for anchor)

FOOTING DETAILS

PROJECT NO: 2024-5740-1	DRAWN BY: G.KAVAL	DATE: 22.07.2024
PROJECT NAME: Florida - Town of Dundee Splash Pad		REV: A
UNIT: FT-INCH		SHEET:
 WATER SPLASH INC. <small>THIS DRAWING IS A PROPERTY OF WATER SPLASH INC. AND IS NOT TO BE REPRODUCED BY ANY MEANS OR USED TO FURNISH INFORMATION TO OTHERS WITHOUT THE EXPRESS CONSENT OF WATER SPLASH INC.</small>		

COMPONENT LIST			
ITEM NO	COMPONENT	MODEL	QTY
A	FEATURE PUMP	HAYWARD HCP55 (5.5hp)	1
B	RECIRCULATION PUMP	HAYWARD Tristar HCP20153 (1.5hp)	1
C	CHEMICAL FEED PUMP	STENNER 45MP3	2
D	SAND FILTER	HAYWARD HCF236 - 36"DIA	1
E	CHEMICAL CONTROL PANEL	HAYWARD CAT-2000	1
F	ELECTRIC CONTROL PANEL	WATER SPLASH INC.	1
G	FLOW METER	BLUE-WHITE F-300	1
H	SELONOID VALVES	RAIN BIRD	7
I	BALL VALVES	-	7
J	CHEMICAL TANKS	26 GALLON EACH	2
K	UV system (OPTIONAL)	AQUJFY AUV-106-03	1

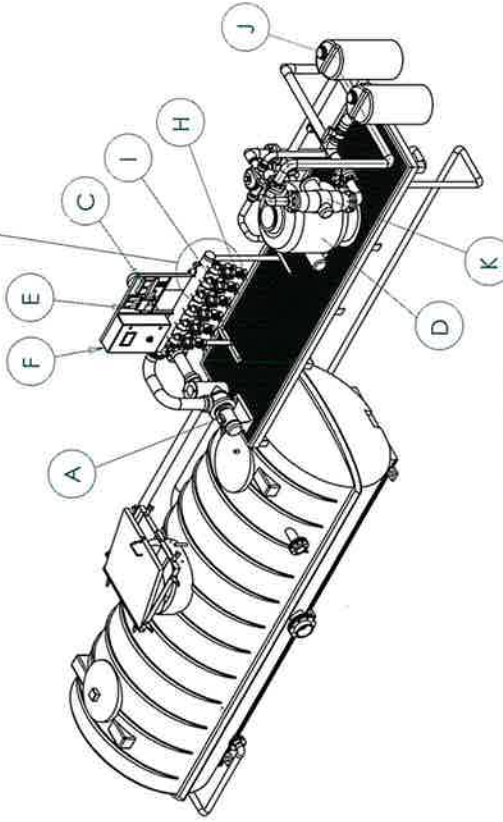
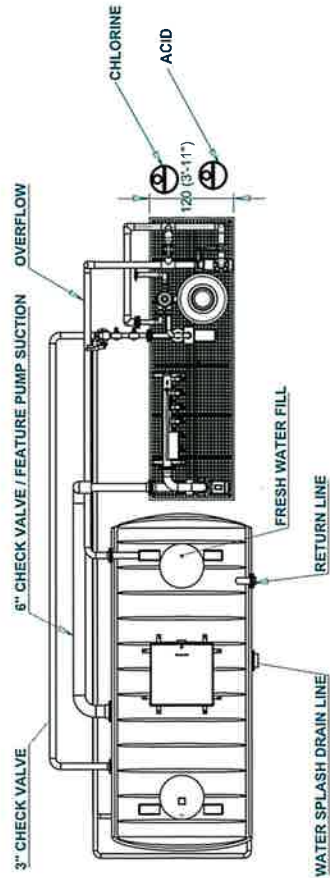
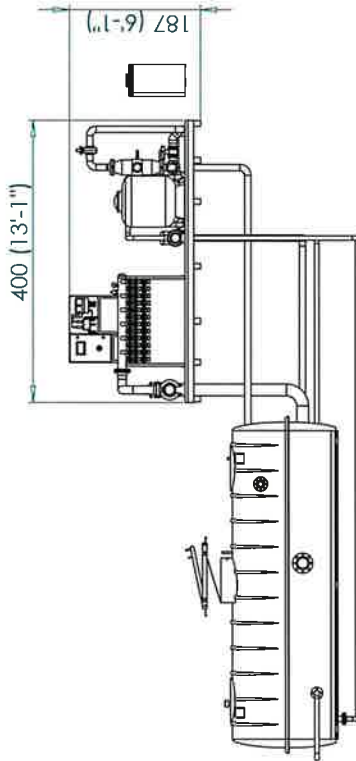
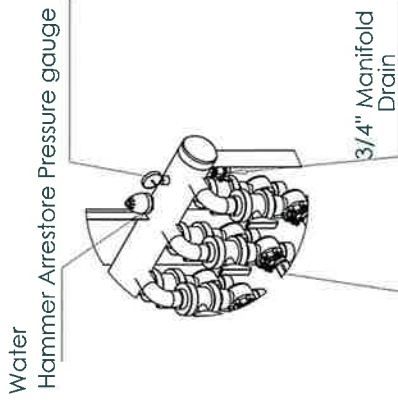

REC. SYSTEM AND TANK CONNECTION

PROJECT NO: IN GENERAL E. YAVUZ DATE: _____

PROJECT NAME: _____

REV: A

UNIT: FT-INCH

WATER SPLASH INC.
THIS DRAWING IS A PROPERTY OF WATER SPLASH INC. AND IS NOT TO BE REPRODUCED BY ANY MEANS OR USED TO FURNISH INFORMATION TO OTHERS WITHOUT THE EXPRESS CONSENT OF WATER SPLASH.

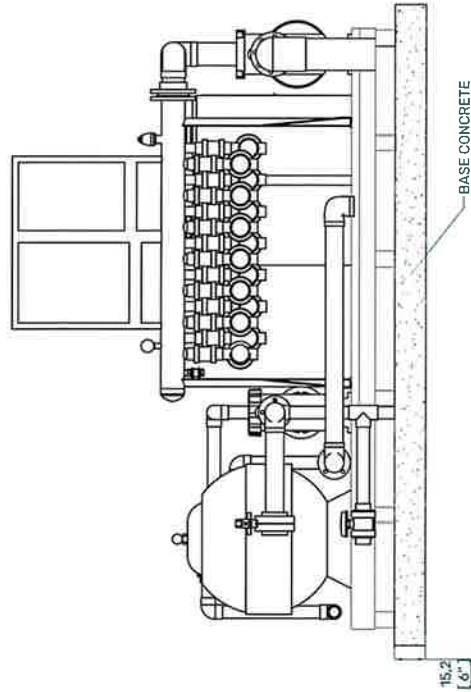
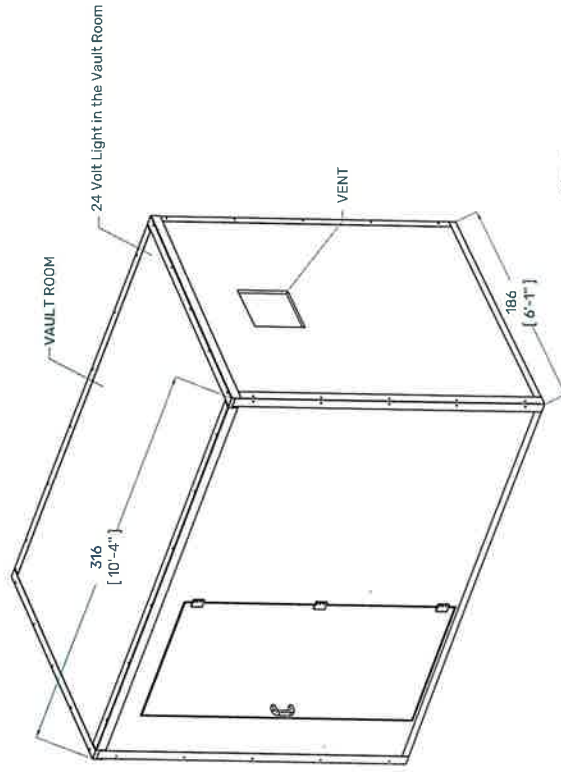
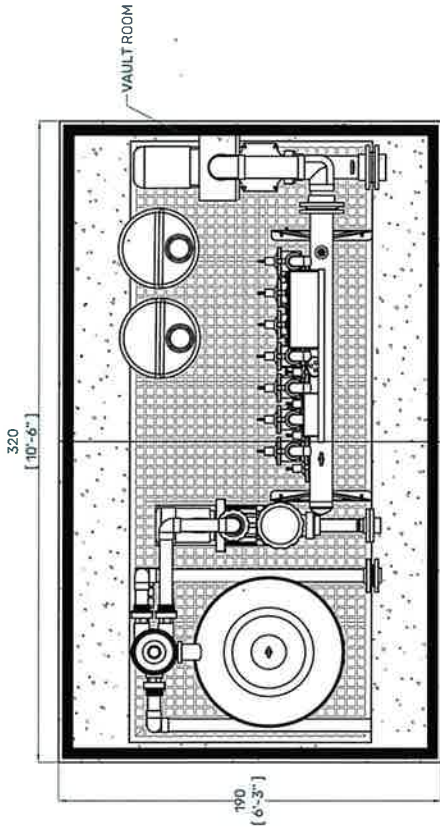

VAULT ROOM BASE CONCRETE
(190 x 320 x 15.2 cm) (10'-6" x 6'-3" x 6")
1.2 yard

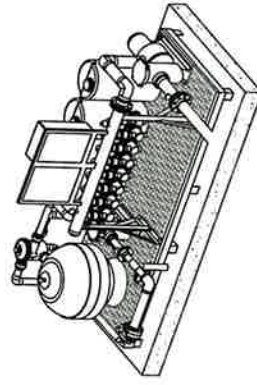

REC. SYSTEM ABOVE GROUND VAULT

PROJECT NO: IN GENERAL	DRAWN BY: E. YAVUZ	DATE:
PROJECT NAME:		REV: A
UNIT: FT-INCH		SHEET:



WATER SPLASH INC.
THIS DRAWING IS A PROPERTY OF WATER SPLASH INC. AND IS NOT TO BE REPRODUCED BY ANY MEANS OR USED TO FURNISH INFORMATION TO OTHERS WITHOUT THE EXPRESS CONSENT OF WATER SPLASH

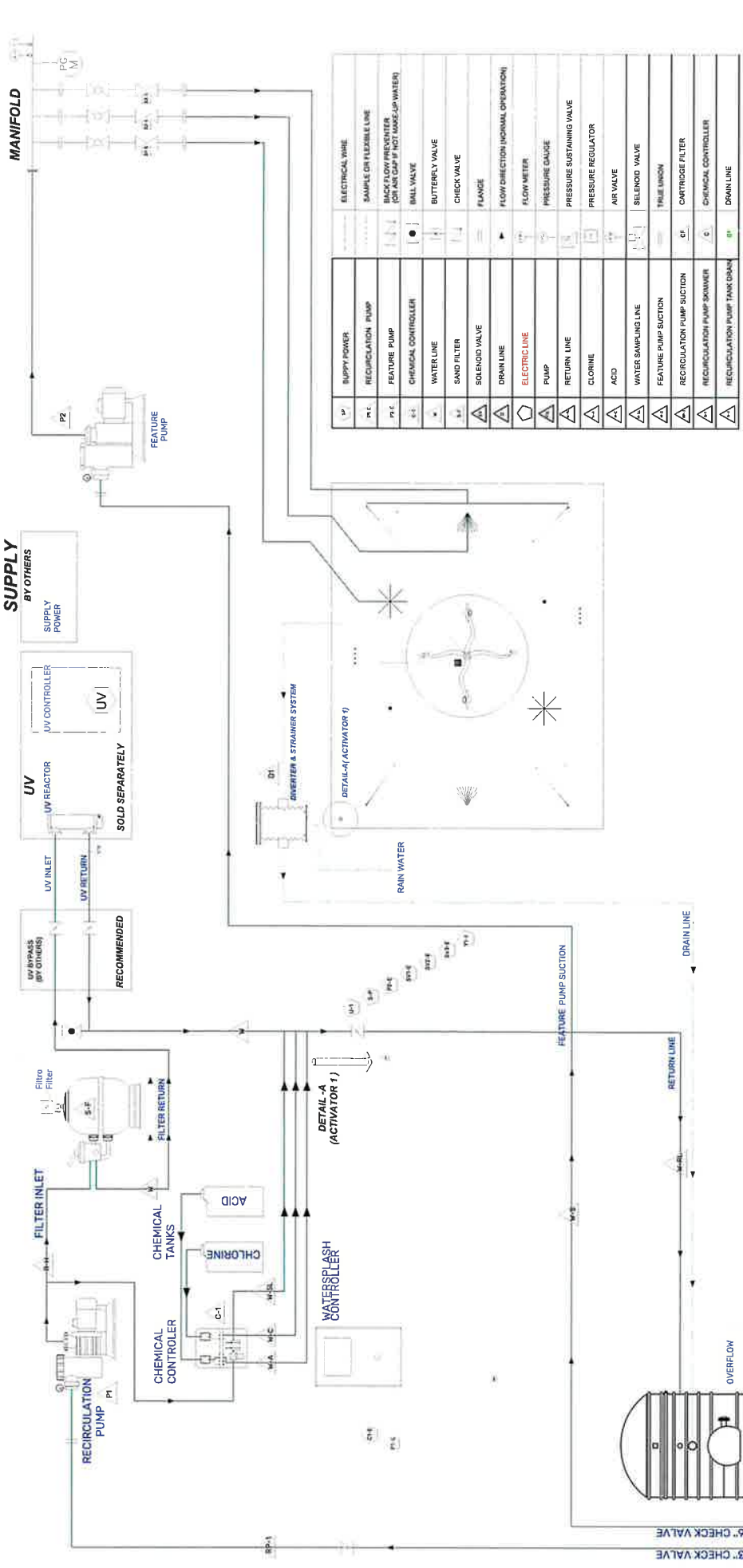

SYMBOL	SUPPLY POWER	ELECTRICAL WIRE
P1	RECIRCULATION PUMP	SAMPLE OR FLEXIBLE LINE
P2	FEATURE PUMP	BACKFLOW PREVENTER (FOR AIR GAP IF HOT MAKE-UP WATER)
CC	CHEMICAL CONTROLLER	BALL VALVE
W	WATER LINE	BUTTERFLY VALVE
S	SAND FILTER	CHECK VALVE
SV	SOLENOID VALVE	FLANGE
D	DRAIN LINE	FLOW DIRECTION (NORMAL OPERATION)
EL	ELECTRIC LINE	FLOW METER
P	PUMP	PRESSURE GAUGE
RL	RETURN LINE	PRESSURE SUSTAINING VALVE
CL	CHLORINE	PRESSURE REGULATOR
AC	ACID	AIR VALVE
WSL	WATER SAMPLING LINE	SOLENOID VALVE
FPS	FEATURE PUMP SUCTION	TRIPLE UNION
RPS	RECIRCULATION PUMP SUCTION	CARTRIDGE FILTER
RPSO	RECIRCULATION PUMP SONNOR	CHEMICAL CONTROLLER
RPSD	RECIRCULATION PUMP TANK DRAIN	DRAIN LINE

IN GENERAL / REC. SYSTEM

PROJECT NO: IN GENERAL DRAWN BY: E.YAYUZ DATE:

REC. SYSTEM DETAILS

REV A UNITS: FT-INCH

WATER SPLASH INC.
 THE DRAWING IS PROPERTY OF WATER SPLASH INC. AND IS NOT TO BE REPRODUCED BY ANY MEANS OR USED TO FURNISH INFORMATION TO OTHERS WITHOUT THE EXPRESS CONSENT OF WATER SPLASH INC.

NOTES:

- 1-Features pump is electrical interlink with:
 - a) UV system (when UV alarm is on feature pump is off)
 - b) Recirculation pump (when recirculation pump is off features pump is off)
 - c) Chemical controller (when treated water quality alarm is on, feature pump is off)
- 2-Recirculation system will work 24 hours a day

PROPOSED SCHEDULE

CONSTRUCTION - SPLASH PARK / RECIRCULATION SYSTEM

Construction Steps	Weeks													
	1	2	3	4	5	6	7	8	9	10	11	12	13	14
Order Received														
Production Start/Finish														
Permit and Construction Start														
Construction area fencing														
Excavation / 14" depth all area														
Anchor Base Concrete Pour														
Drain Box Installation														
Storage Tank Installation														
Securing Products on Concrete Bases														
Securing Manifold on Concrete Base														
Plumbing Connecting / Products to Manifold														
Plumbing / Connecting Manifold to Water Source														
Plumbing / Drain Box connection														
Pressure Testing														
Grounding														
Main Power Inlet to Control Panel														
Gravel, compacting and Leveling														
Pressure Testing														
Concrete Pour - non-slip colored concrete														
New sidewalk to the splash pad to the restroom and the already existing playground.														
Final Repairs - Concrete / Fine Tuning														
Final Test and Training														



Technical Product Specifications

Our Design Includes Products listed below			
NO	Products	Description	Qty
1	Spray Elements	Above Ground	4
		In Ground	10
2	Manifold	7 outputs	1
3	Activator Sensor	Above Ground	1
4	Drain Box	12" x 12"	1
5	Water Recirculation System	In enclosure with UV filter	1
6	Water Storage Tank	2500 gallons	2
7	Water Wise Controller	Water Splash Inc.	1

- All metal products are made of 304/304L stainless steel material
- Nozzles, water openings and sprayers are made of stainless steel material.
- Water Splash provides special tamper-resistant tools. All products are offered with winter caps.
- The painted finish of all equipment is a high-quality, UV resistance. powder coating of oven-cured glossy polyester, with stabilizers and chlorinated water resistance.
- Spray nozzles are recessed, welding marks are invisible (buffed and polished) and equipment is pressure tested for leakage.
- Products comply with the ADA (Americans with Disabilities Act) and CDA (Canadians with Disabilities Act).



SEA TURTLE BUCKETS S-06.01



High action

Flow Rate	10-15 gpm - 37-50 lpm	Material Detail	Coating / Graphic Design
Pressure	8-15 psi - 1.25-1.7 bar	Commercial, non corrosive, chemical resistant 304/304L quality Stainless steel and glass reinforced polyester material with brass nozzles	UV and chemical resistant, oven cured, polyester powder coating. UV and chemical resistant, commercial grade epoxy coated spray paint
Height	155.5" - 395 cm		Pipe Diameter ø3" - ø90 mm
Length	-	Play Zones	Add-in Options
Width	145" - 368 cm	Toddler Family Dynamic	To Removable
Spray Zone	ø162" - ø412 cm		

www.watersplashnet.com
(800) 936-3430



ORANGE LOOP S-03.02.34



Flow Rate	10-14 gpm - 36-53 lpm	Material Detail Commercial, non corrosive, chemical resistant 304/304L quality stainless steel and glass reinforced polyester material with brass nozzles	Coating / Graphic Design UV and chemical resistant, oven cured, polyester powder coating. UV and chemical resistant, commercial grade epoxy coated spray paint.
Pressure	8-14 psi - 0.5-1 bar		
Height	117" - 297 cm		
Length	-		
Width	85" - 216 cm ø		
Spray Zone	100" - ø254 cm	Play Zones Toddler Family Dynamic	Pipe Diameter ø3" - ø90 mm
			Add-in Options  Removable

AQUA ORANGE S-02.77



Flow Rate	8-14 gpm - 30-53 lpm	Material detail Commercial, non corrosive, chemical resistant 304/304L quality Stainless steel construction with brass nozzle	Coating / Graphic Design	
Pressure	8-15 psi - 0.5-1 bar		UV and chemical resistant, oven cured, polyester powder coating	
Height	22" - 56 cm		Pipe Diameter	ø4" - ø115 mm
Length	-		Add-In Options	
Width	19.6" - 50 cm	Play Zones	 Removable	
Spray Zone	ø 60" - ø 152 cm	Toddler Family Dynamic		

www.watersplashnet.com
(800) 936-3430



AQUA SPHERE I S-02.09.01





Flow Rate	5-7 gpm - 19-26 lpm	Material Detail	Coating / Graphic Design
Pressure	4-6 psi - 0.3-0.6 bar		
Height	24" - 60 cm	Commercial grade, non corrosive, UV and chemical resistant, glass reinforced polyester material with brass nozzle	UV and chemical resistant, commercial grade epoxy coated spray paint
Length	-		
Width	24" - 60 cm		
Spray Zone	ø35.4" - ø90 cm	Play Zones	Add-in Options
		Toddler Family Dynamic	<input type="checkbox"/> 10 Removable

www.watersplashnet.com
(800) 936-3430





AQUA JET S-05.01



Flow Rate	3-4 gpm- 11-15 lpm	Material Detail	Coating / Graphic Design
Pressure	4-6 psi - 0.3-0.8 bar	Commercial, non corrosive, chemical resistant 304/304L quality Stainless steel construction with brass directional nozzle	
Height	-		Add-in Options
Width	-	Play Zones	 Led Lighting  Removable
Spray Zone	ø50" - ø127cm	Toddler Family Dynamic	



AQUA JET VERTICAL S-05.01.04



Flow Rate	3-4 gpm- 11-15 lpm	Material Detail	Coating / Graphic Design
Pressure	4-6 psi - 0.3-0.8 bar	Commercial, non corrosive, chemical resistant 304/304L quality Stainless steel construction with brass directional nozzle	
Height	-		
Width	-	Play Zones	Add-in Options
Spray Zone	ø50" - ø127cm	Toddler Family Dynamic	 Led Lighting  Removable

AQUA GEYSER S-05.06.01



Flow Rate	5-7 gpm - 19-26 lpm	Material Detail	Coating / Graphic Design
Pressure	4-6 psi - 0.3-0.4 bar	Commercial, non corrosive, chemical resistant 304/304L quality Stainless steel construction with brass nozzle	
Height	-		Add-in Options
Width	-	Play Zones	 
Spray Zone	ø60" - ø152 cm	Toddler Family Dynamic	Led lighting Removable

www.watersplashnet.com
(800) 936-3430



LED ACTIVATOR SENSOR S-20.14



Led lighting

Flow Rate	-	Material Detail Commercial, non corrosive, chemical resistant 304/304L quality Stainless steel construction	Coating / Graphic Design	
Pressure	-		UV and chemical resistant, oven cured, polyester powder coating	
Height	51" - 130 cm		Pipe Diameter	ø5" - ø140mm
Length	-		Add-in Options	
Width	-		 Removable	
Spray Zone	-	Play Zones		

www.watersplashnet.com
(800) 936-3430



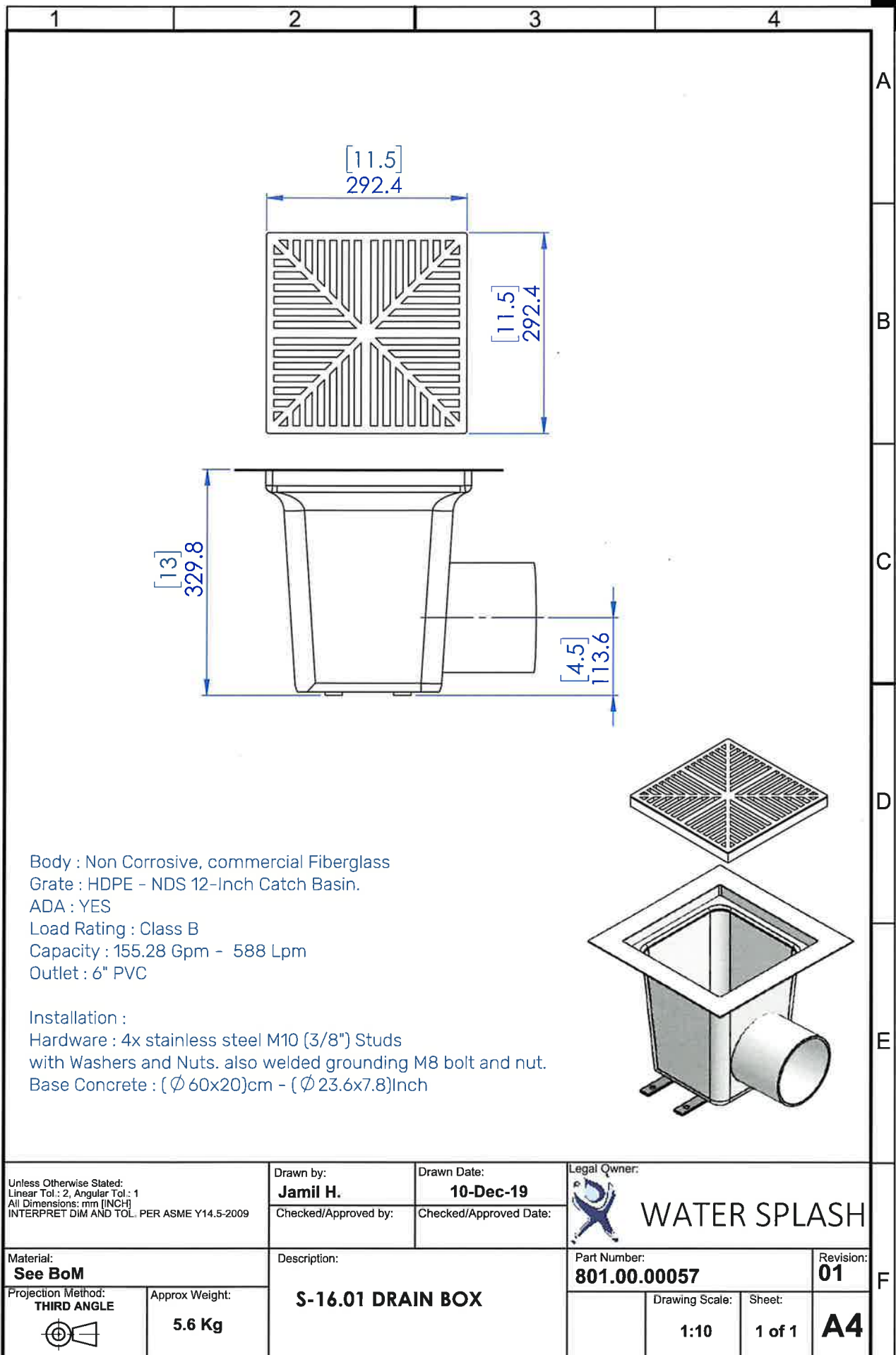

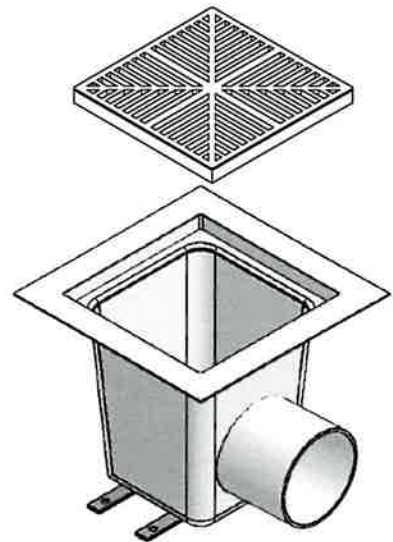

Body : Non Corrosive, commercial Fiberglass
 Grate : HDPE - NDS 12-Inch Catch Basin.
 ADA : YES
 Load Rating : Class B
 Capacity : 155.28 Gpm - 588 Lpm
 Outlet : 6" PVC

Installation :
 Hardware : 4x stainless steel M10 (3/8") Studs
 with Washers and Nuts. also welded grounding M8 bolt and nut.
 Base Concrete : (ϕ 60x20)cm - (ϕ 23.6x7.8)Inch



Unless Otherwise Stated: Linear Tol : 2, Angular Tol : 1 All Dimensions: mm [INCH] INTERPRET DIM AND TOL. PER ASME Y14.5-2009		Drawn by: Jamil H.	Drawn Date: 10-Dec-19	Legal Owner:  WATER SPLASH
Material: See BoM		Description: S-16.01 DRAIN BOX		Part Number: 801.00.00057
Projection Method: THIRD ANGLE 	Approx Weight: 5.6 Kg	Drawing Scale: 1:10		Sheet: 1 of 1
				Revision: 01 A4

RECIRCULATION SYSTEM

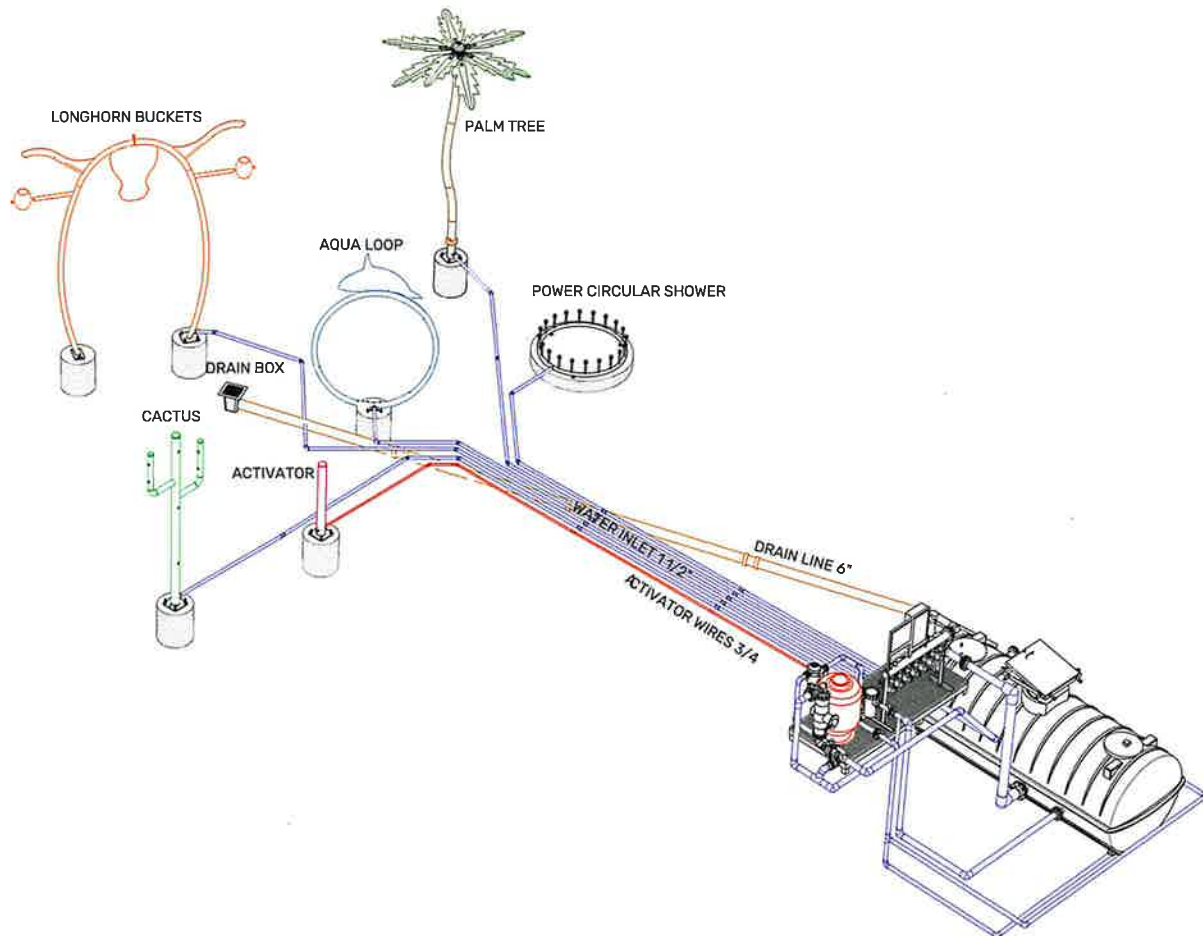

Splash park with Water Re-Capture system, re-uses water utilized at splash park by filtration and sanitizing constantly. This system is similar to swimming pool water sanitization system. Engineered to meet state / provincial health codes for swimming to pool/splash pads.

We offer tank sizes (1320,2500 and 4000) Gallons with 1" float valve for fresh water intake.

Stainless steel manifold

Electric controller

Factory assembled and tested pumps/sand filter and chemical controller kit.

Optional: UV

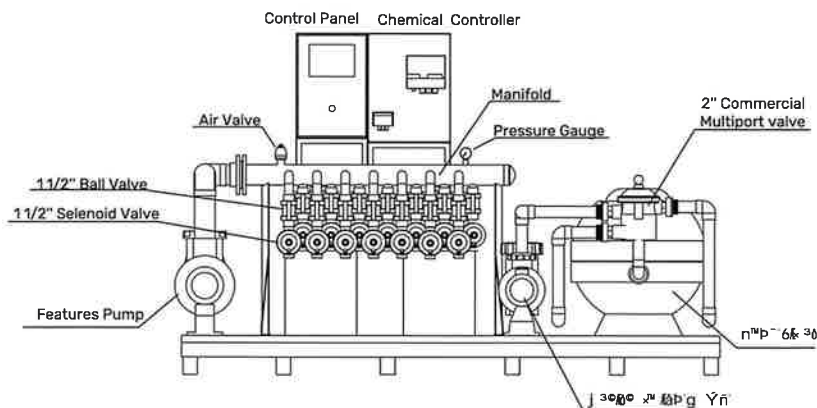

WATER WISE CONTROLLER



Water Wise Controller - Fiberglass enclosure has center PLC unit controlling each manifold line. Touch screen interface allows users to set desired programming setting for splash park.

Controller is user programmable and following functions can be programmed;

- 1- Current day and time
- 2- Setting active hours / always on
- 3- Activate products via activator or always on
- 4- Spray time
- 5- Up to five spray play sequences
- 6- Product selection per each sequence
- 7- Wind speed effect (optional)
- 8- Low water temperature on/off (optional)
- 9- Battery back up

Water Wise Controller

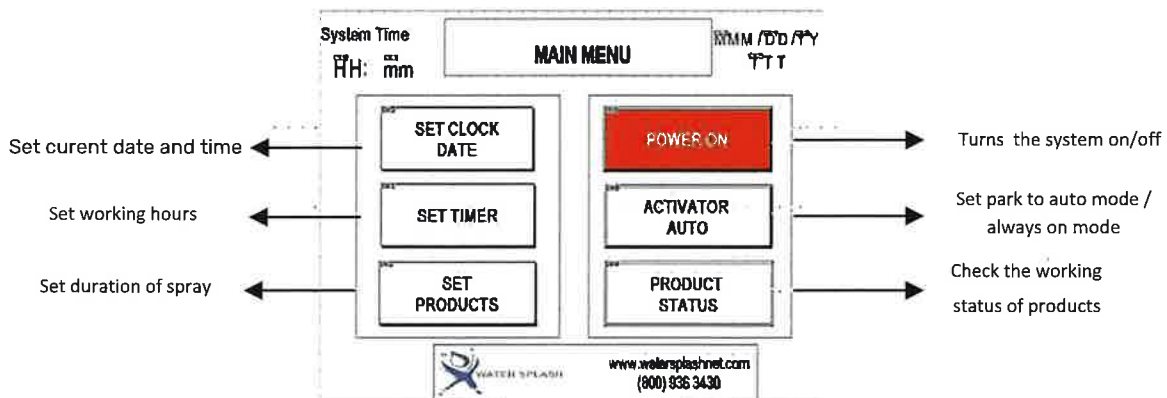

User Interface

The user interface is a fabulous touch screen, which is easy to use and operate. This user interface (UI) will allow the staff to control, monitor and maintain the use of the park and its products efficiently.



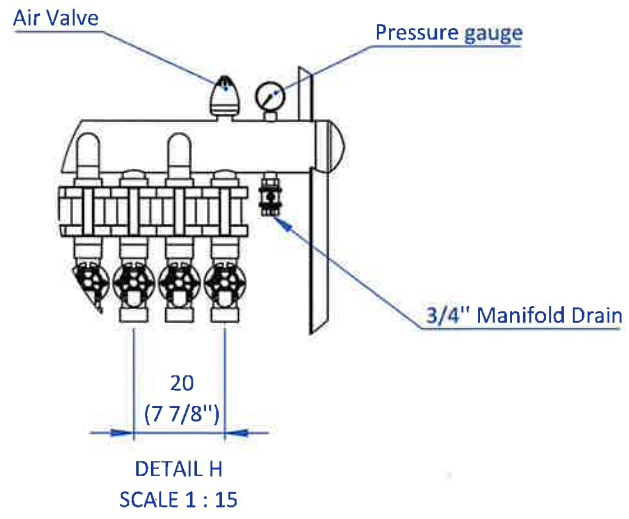
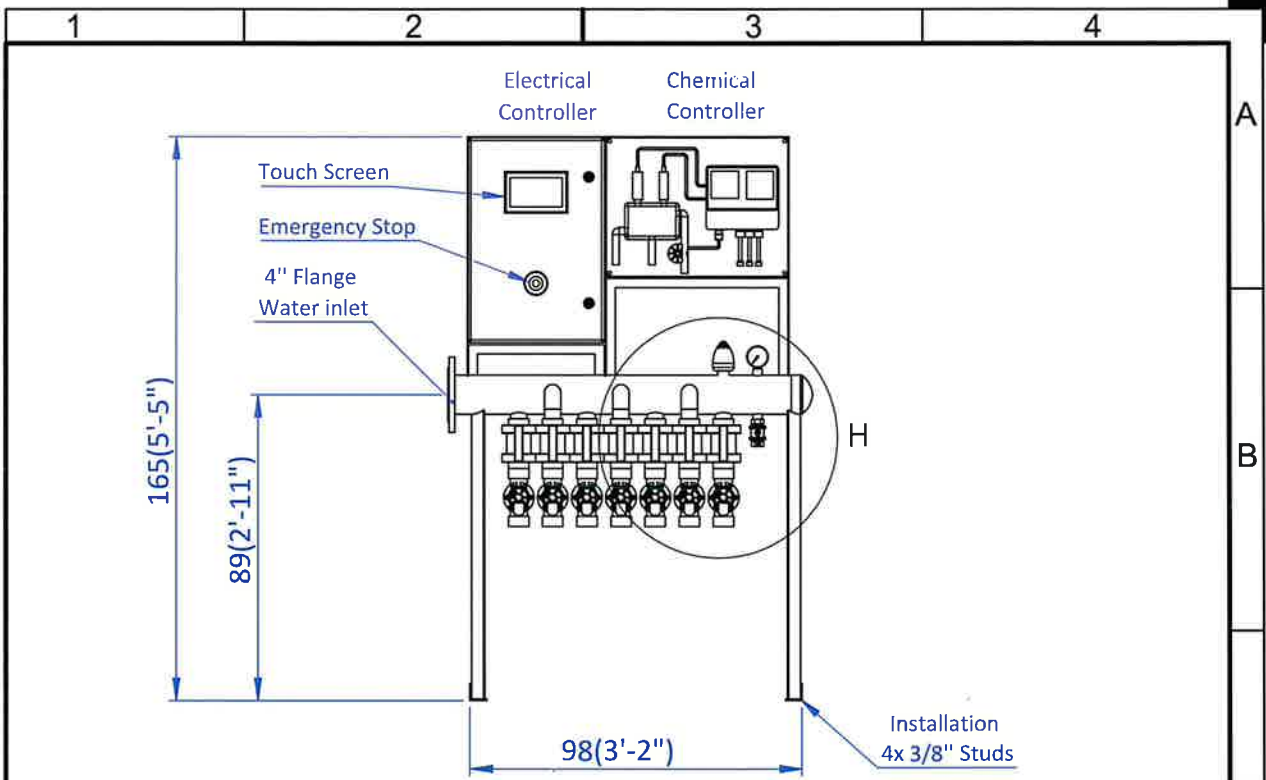

www.watersplashnet.com
(800) 936-3430



Manifold housing is consist of commercial grade, non corrosive, 304L grade 4" stainless steel tubing. Housing shall have a 4" flange for water inlet.

Manifold lines are assembled using commercial grade, SCH80 PVC piping and pipe fittings .each manifold line consist of :

- One double union ball valve
- One solenoid valve
- Winterization valve connection

Unless Otherwise Stated: Linear Tol : 2, Angular Tol : 1 All Dimensions: cm (ft-inch) INTERPRET DIM AND TOL. PER ASME Y14.5-2009		Drawn by: G.YAYMAN	Drawn Date: 30.06.2020	Legal Owner:  WATER SPLASH	
		Checked/Approved by:	Checked/Approved Date:		
Material:		Description:		Part Number:	
Projection Method: THIRD ANGLE 		Approx Weight: gr		Revision:	
		S-10.07 7 Output Manifold		Drawing Scale:	Sheet:
				1:20	A4

Products Warranty

2024-5740-1 Florida - Town of Dundee Splash Pad

Water Splash Inc. guarantees that all products meet the specifications provided in the installation drawings and offers.

25 YEAR WARRANTY on stainless steel structures and workmanship, stainless steel anchoring systems and aluminum spheres, stainless steel Piping and Weldments.

5 YEAR WARRANTY on Acetyl, Urethane/HPDE parts, spray nozzles and spray openings, high density polyethylene components, polyurethane components, stainless steel automated water distribution manifold, drain boxes and electrical enclosures.

2 YEAR WARRANTY on coatings (Airbrushed Graphics), powder coated, stainless steel hardware and moving parts, fiberglass components, seeflow polymers (polycarbonate materials), toe guards, piping, fittings, ball valves, pressure gauges, terminal blocks, PLC controller, time switches, manual switches, transformers, breakers, electrical wiring, connections and on recirculation system workmanship, recirculation system pumps and filters are covered by their manufacturer. Please refer to their warranty documentation.

1 YEAR WARRANTY on all products and parts not listed above.

Warranty above is valid only if structures are installed or assembled as per Water Splash's installation instructions/drawings maintained according to maintenance manual and procedures, not subject to misuse, vandalis, operated under normal use as per designed purpose or have not modified/repared by unauthorized personnel.



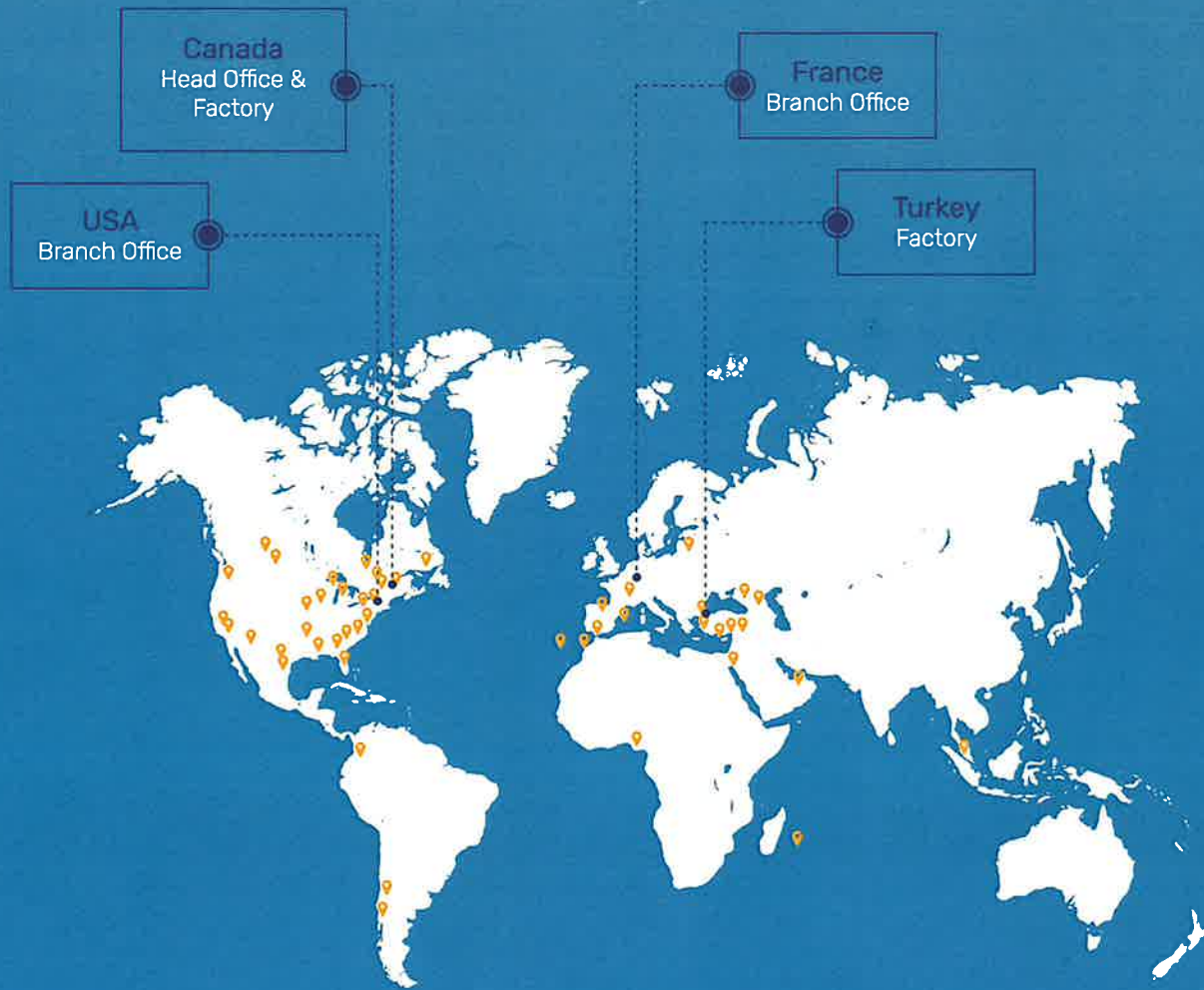

WATERSPLASH INSTALLATIONS AROUND THE WORLD

Singapore • Chile • Turkey • Nigeria • Russia • Canaries • United Arab Emirates
 USA • Poland • Colombia • Spain • Reunion • Jordan • Canada • Hong Kong



USA/Canada (800) 936-3430
 France +33 172 77 43 28
www.watersplashnet.com
info@watersplashnet.com
 [Facebook] [Twitter] [Instagram] [LinkedIn] watersplashinc