

CALLED 0.38 ACRES  
TRACT 1  
URIEGAS DEVELOPMENT, LLC.  
DOCUMENT# 21026213  
O.P.R.H.C.TX.

CALLED 0.34 ACRES  
TRACT 2  
URIEGAS DEVELOPMENT, LLC.  
DOCUMENT# 21026213  
O.P.R.H.C.TX.

CALLED 0.332 ACRES  
JAMES DILLINGER HUDSON  
VOL 536 PG 435  
R.P.R.H.C.TX.

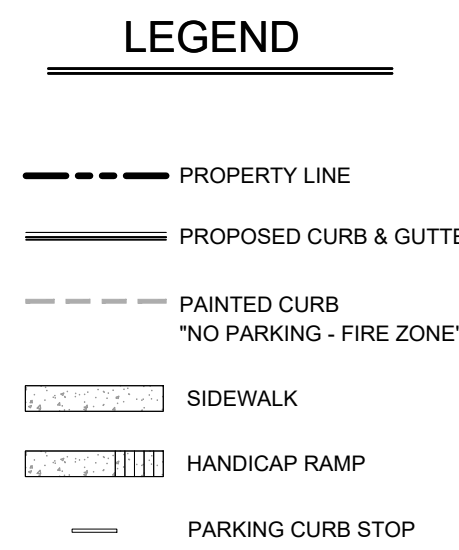
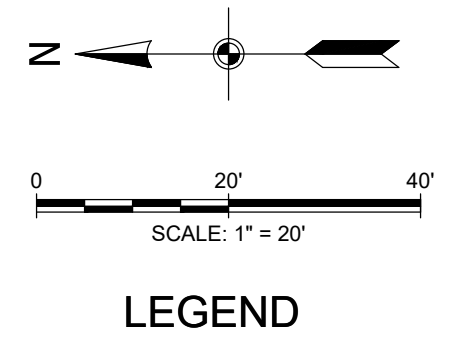

**DIMENSIONAL SITE PLAN NOTES**

1. SIDEWALKS AND CURB RAMPS TO BE CONSTRUCTED PER CITY OF DRIPPING SPRINGS STANDARDS.
2. EVERY HANDICAP-DESIGNATED PARKING SPACE MUST BE IDENTIFIED BY A SIGN CENTERED AT THE HEAD OF THE PARKING SPACE. THE SIGN MUST INCLUDE THE INTERNATIONAL SYMBOL OF ACCESSIBILITY AND STATE "RESERVED" OR EQUIVALENT LANGUAGE CHARACTERS AND SYMBOLS ON SUCH SIGNS MUST BE LOCATED 60" MINIMUM ABOVE THE GROUND.
3. ALL HANDICAP SPACES (H.C.) ARE 9'-WIDE. H.C. SPACES MARKED AS VAN-ACCESSIBLE HAVE AN 9'-WIDE ACCESS AISLE.
4. "ALL EXTERIOR LIGHTING WILL BE FULL CUT-OFF AND FULLY SHIELDED IN COMPLIANCE WITH SUBCHAPTER E 2.5 AND WILL BE REVIEWED DURING BUILDING PLAN REVIEW. ANY CHANGE OR SUBSTITUTION OF LAMP/LIGHT FIXTURES SHALL BE SUBMITTED TO THE DIRECTOR FOR APPROVAL IN ACCORDANCE WITH SECTION 2.3.2E."
5. PER CHAPTER 8, THE DUMPSTER ENCLOSURES MUST BE ONE (1) FOOT ABOVE THE HEIGHT OF THE WASTE CONTAINER. USE PROTECTIVE POLES IN CORNERS AND AT IMPACT AREAS. FENCE POSTS OF RUST PROTECTED METAL OR CONCRETE. A MINIMUM 6" SLAB IS REQUIRED AND MUST BE SLOPED TO DRAIN; THE ENCLOSURE MUST HAVE STEEL FRAMED GATES WITH SPRING LOADED HINGES AND FASTENERS TO KEEP CLOSED. SCREENING MUST BE ON ALL FOUR SIDES BY MASONRY WALL OR APPROVED FENCE OR SCREENING WITH OPAQUE GATES.
6. ALL WALLS 30" OR HIGHER THAN FINAL GRADE AND ALONG PEDESTRIAN OR VEHICULAR ROUTES MAY NEED HANDRAIL. CONTRACTOR TO COORDINATE HANDRAIL LOCATIONS WITH OWNER AND ENGINEER DURING CONSTRUCTION.
7. ALL DIMENSIONS ARE REFERENCED TO BACK OF CURB, OR TO EDGE OF GRAVEL DRIVEWAY WHERE CURB IS NOT PLANNED.
8. ALL DRIVING SURFACES SHALL BE ABLE TO BE ENGINEERED TO WITHSTAND 75,000 LBS. 2012 IFC 503 AND D102.1

NO.	DATE	DESCRIPTION	BY
1	10/11/2019	ISSUE 2. ADDENDUM #1	

URIEGAS DENTAL - DRIPPING SPRINGS  
OLD FITZHUGH ROAD  
DRIPPING SPRINGS, TEXAS 78620

**SITE PLAN**

THIS DOCUMENT IS RELEASED FOR REVIEW PURPOSES UNDER THE AUTHORITY OF ANDREW W. DODSON, P.E. 95647 ON May 11, 2022 IT IS NOT TO BE USED FOR BIDDING, PERMIT OR CONSTRUCTION PURPOSES.

Date: 5/11/2022  
Check by: AWD  
Drawn By: MBS  
Sheet No. ---- of 14  
Project No.

