



9600 Escarpment Blvd., Suite 745-4
Austin, Texas 78789

Date: 04.01.22
Project: Village Grove
City of Dripping Springs
Parkland Dedication Plan

MEMORANDUM

To: Howard Koontz, City of Dripping Springs City Planner
Laura Mueller, City of Dripping Springs City Attorney

Cc: N/A

This memo serves as follow-up correspondence to the review by LUCK Design Team, LLC of the Village Grove Parkland Dedication Plan submitted March 31, 2022. Please see attached Parkland Dedication Plan Narrative and site plans.

*** **

Note: This review is considered an initial review to ensure the comments from this review and discussion are taken into consideration as the project moves through PDD and MUD review. It is our understanding that the Parks and Recreation Commission will have the chance to review the proposed park development again as the project goes through the platting stage.

After review we have the following observations and recommendations:

1. At 511 proposed residential units, the amount of parkland required per ordinance is 22.22 acres.
2. A total of 30.91 acres of physical land is being dedicated to the City as public parkland as broken down below:
 - a. Public Parks – Total = 2.36 acres
 - b. Public Open Space = 16.27
 - c. Amenity Pond = 4.94 acres
 - d. Private Parkland = 7.34
3. The amount of parkland dedication acreage exceeds ordinance requirements by 8.69 acres.
4. The parkland development fee required by ordinance for the 511 acres is \$331,128. The developer has indicated that the full amount of that parkland development fee will be paid.
5. A trail connection along the south minor collector road is proposed by the developer that will connect the residential part of the community to Dripping Springs Sports Park. This trail surface is concrete.
6. The 1.0 acres of parkland central to the development is located there to primarily serve as a neighborhood park and will be passive in nature.
7. The edge treatment where the north-south minor collector interfaces with Dripping Springs Sports and Recreation Park needs to be discussed and vetted further, specifically in regards to:

- a. Perimeter fencing and providing a barrier between soccer players and vehicular traffic along the minor collector;
 - b. Extending the concrete trail along the north-south minor collector from the west amenity pond to Rob Shelton Blvd.;
 - c. Mitigating the existing drainage swale at the Sports Park where the north-south minor collector is proposed; see Exhibit A.
 - d. Mitigating the 2.1-acres of dedicated open space that is part of an agreement between Texas Parks and Wildlife and the City of Dripping Springs. The north-south minor collector goes through this open space area; See Exhibit B.
 - e. Sports lighting has been designed for the Sports Park soccer fields; a Phase 1 meter is located in the proposed north-south minor collector corridor and it will need to be relocated/redesigned, See Exhibit C.
-

Prepared By: Brent Luck

EXHIBIT A

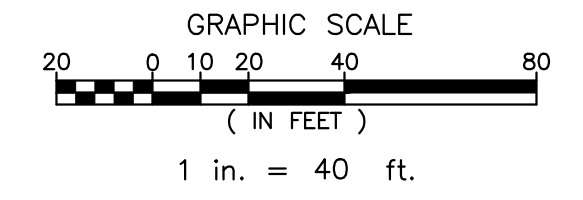

PLAN LEGEND

- PROPERTY LINE
- EASEMENT
- BUILDING LINE
- CURB AND GUTTER
- CONCRETE SIDEWALK
- 840 EXISTING CONTOUR
- 840 PROPOSED CONTOUR

NOTES:

1. EXISTING & PROPOSED GRADES ARE APPROXIMATE, BASED ON RECORD DRAWINGS.
2. NO IRRIGATION REQUIRED BY CONTRACTOR.

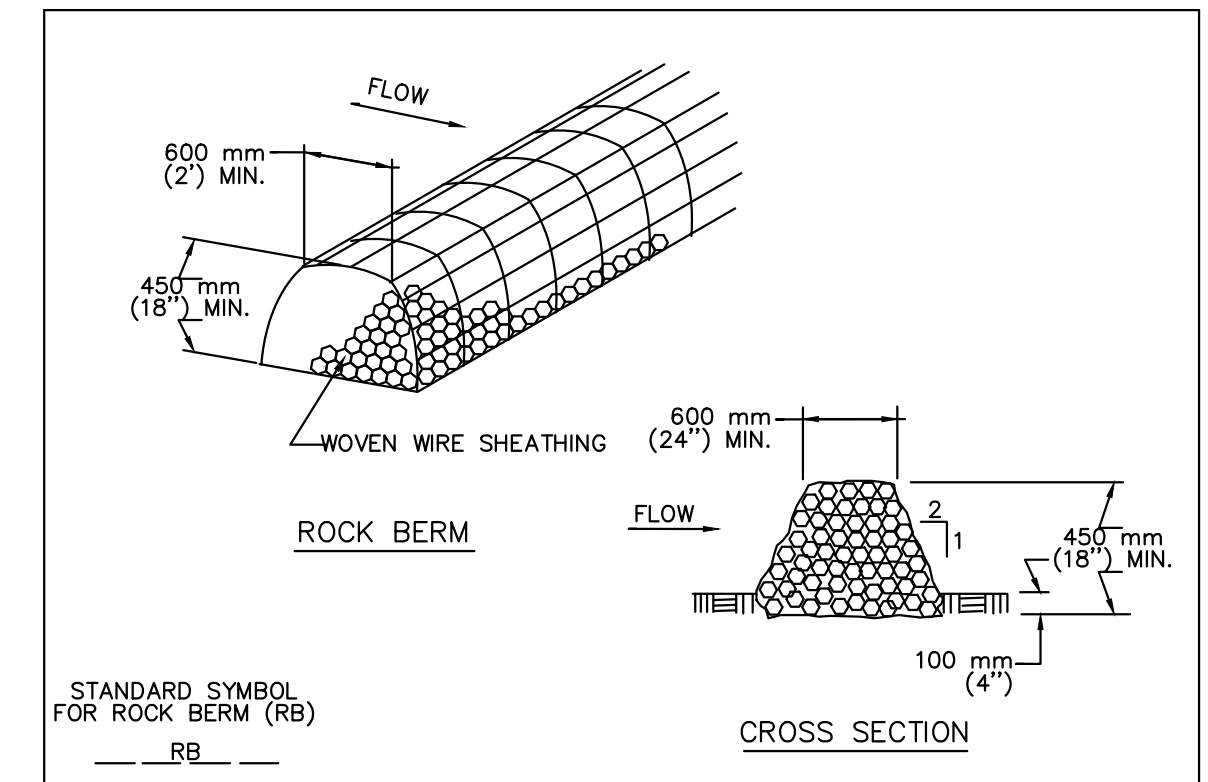
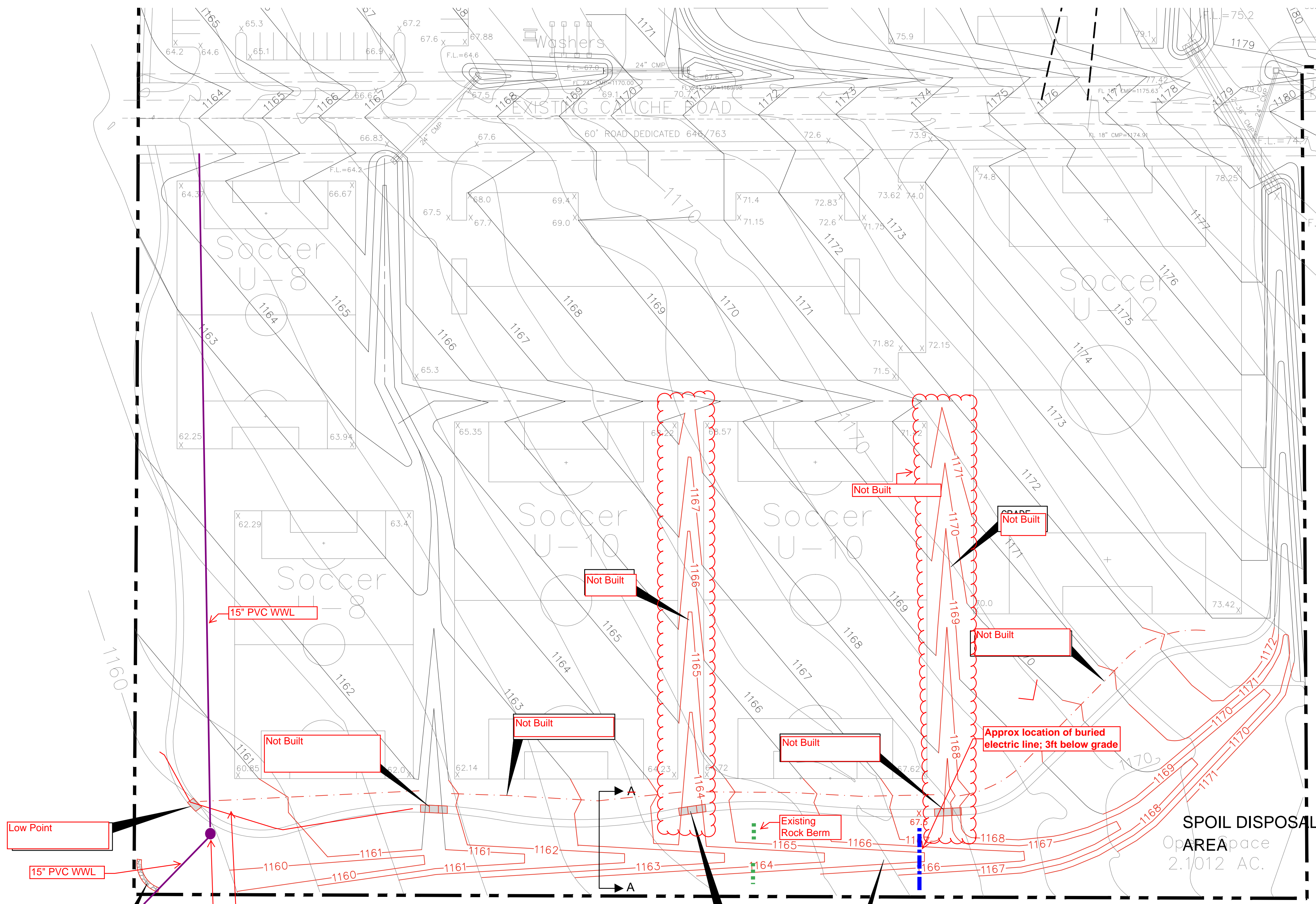

- STANDARD SYMBOL FOR ROCK BERM (RB)
- CROSS SECTION
- NOTES:
1. USE ONLY OPEN GRADED ROCK 100 TO 200 mm (4 TO 8") DIAMETER FOR STREAM FLOW CONDITIONS. USE OPEN GRADED ROCK 75 TO 125 mm (3 TO 5") DIAMETER FOR OTHER CONDITIONS.
 2. THE ROCK BERM SHALL BE SECURED WITH A WOVEN WIRE SHEATHING HAVING MAXIMUM 25 mm (1") OPENING AND MINIMUM WIRE DIAMETER OF 12.9 mm (20 GAUGE). ROCK BERMS IN CHANNEL APPLICATIONS SHALL BE ANCHORED FIRMLY INTO THE SUBSTRATE A MINIMUM OF 150 mm (6") WITH 1-POSTS OR WITH 15M OR 20M (#5 OR #6) REBAR, WITH MAXIMUM SPACING APART OF 1.2 m (48") ON CENTER.
 3. THE ROCK BERM SHALL BE INSPECTED WEEKLY OR AFTER EACH RAIN, AND THE STONE AND/OR FABRIC CORE-WOVEN SHEATHING SHALL BE REPLACED WHEN THE STRUCTURE CEASES TO FUNCTION AS INTENDED, DUE TO SILT ACCUMULATION AMONG THE ROCKS, WASHOUT, CONSTRUCTION TRAFFIC DAMAGE, ETC.
 4. WHEN SILT REACHES A DEPTH EQUAL TO ONE-THIRD THE HEIGHT OF THE BERM OR 150 mm (6"), WHICHEVER IS LESS, THE SILT SHALL BE REMOVED AND DISPOSED OF ON AN APPROVED SITE AND IN A MANNER THAT WILL NOT CREATE A SILTATION PROBLEM.
 5. DAILY INSPECTION SHALL BE MADE ON SEVERE-SERVICE ROCK BERMS; SILT SHALL BE REMOVED WHEN ACCUMULATION REACHES 150 mm (6").
 6. WHEN THE SITE IS COMPLETELY STABILIZED THE BERM AND ACCUMULATED SILT SHALL BE REMOVED AND DISPOSED OF IN AN APPROVED MANNER.

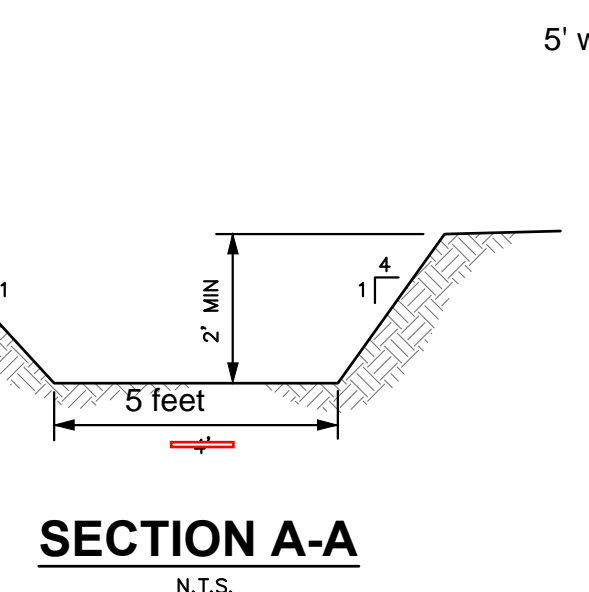

CITY OF AUSTIN WATERSHED PROTECTION DEPARTMENT		ROCK BERM	STANDARD NO.
RECORD COPY SIGNED BY J. PATRICK MURPHY	5/23/00 ADOPTED	THIS ARCHITECT/ENGINEER ASSUMES RESPONSIBILITY FOR APPROPRIATE USE OF THIS STANDARD.	639S-1

DRIPPING SPRINGS
SPORTS & RECREATION PARK
DRAINAGE IMPROVEMENTS

TEXAS RECREATION AND PARKS ACCOUNT AGREEMENT

(Revised August 31, 1995)

Project Name and Number: DRIPPING SPRINGS RECREATIONAL COMPLEX, PROJECT NUMBER 50-00162

Project Period: TPWD Approval Date to 02-28-2001

Total Project Cost: \$808,750.00

Approved State Funds: \$404,375.00

PROJECT DESCRIPTION (SCOPE):

The City of Dripping Springs will acquire by donation and develop 37 acre Recreational Complex to include a 2.1 acre open space dedication, baseball field, softball field, 4 soccer fields, volleyball court, playground, covered basketball court, ropes course, 1.1 mile trail, 4 horseshoe pits, 4 washer pitching pits, 22 picnic tables, 20 benches, wildscape garden, interpretive kiosk, xeriscaping, and signs.

Recreational Complex is located in the south area of the city off of RR 12.

Pre-agreement costs incurred from July 31, 1997 to the date of project approval in the amount not to exceed \$67,000.00 shall be allowable.

It is understood that a 2.1 acre open space dedication will be made prior to reimbursement for land.

For and in consideration of the mutual covenants and benefits hereof, the Texas Parks and Wildlife Department ("Department") and the "Sponsor" hereby contract with respect to the above described project as follows:

1. The Sponsor is obligated to adhere to all requirements established for the Texas Recreation and Parks Account Program including program guidelines set out at 31 TAC Sec. 61.132 - 61.137.
2. No work on the project by the Sponsor shall commence until written notice to proceed has been received from the Department.
3. The Sponsor shall furnish the Department an annual report for a period of five years following the project completion providing to the satisfaction of the Department information regarding present and anticipated use and development of the project site.
4. The Sponsor shall install and maintain at the project site a permanent fund acknowledgment sign as prescribed by the Department.
5. All utilities at the project site shall be underground and approved by the Department.
6. The General Provisions dated September 1994 attached hereto are hereby made part of this agreement
7. The Summary of Guidelines for Administration of Local Park Grant Assistance Projects dated September 1994 attached hereto is hereby made part of this agreement.
8. The Agreement is effective upon execution by the Department.

TEXAS PARKS AND WILDLIFE DEPARTMENT

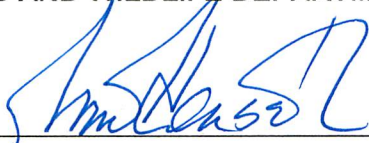
by 

Tim Hogsett, Director, Recreation Grants Branch

(Project Approval Date)

CITY OF DRIPPING SPRINGS
POLITICAL SUBDIVISION (SPONSOR)

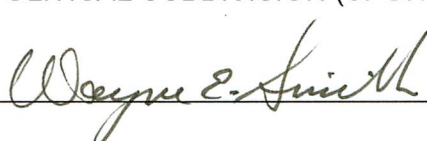
by 

Wayne E. Smith
Terry Garnett, Mayor

7-17-95
(Date)

TEXAS PARKS AND WILDLIFE DEPARTMENT

CERTIFICATE OF LAND DEDICATION FOR PARK USE

TEXAS RECREATION AND PARKS ACCOUNT PROGRAM

This is to certify that a permanent record shall be kept in the **CITY OF DRIPPING SPRINGS** public property records and be made available for public inspection to the effect that the property described in the scope of the project Agreement for **Recreational Complex** Project Number **51-00162**, and the dated project boundary map made part of that Agreement, has been acquired or developed with Texas Recreation and Parks Account assistance and that it cannot be converted to other than public recreation use without the written approval of the Texas Parks and Wildlife Department.

CITY OF DRIPPING SPRINGS
POLITICAL SUBDIVISION

by Wayne E. Smith

Wayne E. Smith
~~Terry Garnett, Mayor~~

(Name and Title)

Date 7-17-98

B. Project Application

1. The Application for State Assistance bearing the same project number as the agreement and associated documents is by this reference made a part of the agreement.
2. The sponsor possesses legal authority to apply for the grant and to finance and construct the proposed facilities. A resolution, or similar action has been duly adopted or passed authorizing the filing of the application, including all understandings and assurances contained therein, and directing and authorizing the person identified as the official representative of the sponsor to act in connection with the application and to provide such additional information as may be required.
3. The sponsor has the ability and intention to finance the non-State share of the costs for the project. Sufficient funds will be available to assure effective operation and maintenance of the facilities acquired or developed by the project.

C. Project Execution

1. The project period shall begin with the date of approval of the project agreement or the effective date of a waiver of retroactivity and shall terminate at the end of the stated or amended project period unless the project is completed or terminated sooner, in which event the project period shall end on the date of completion or termination.
2. The sponsor will cause work on the project to be commenced within a reasonable time after receipt of notification that funds have been approved and assure that the project will be prosecuted to completion with reasonable diligence.
3. The sponsor will require the facility to be designed to comply with the minimum requirements for accessibility for the handicapped in conformance with the Texas Architectural Barriers Act (Article 9102 - Texas Civil Statutes), and the Americans with Disabilities Act of 1990 (PL 101-336). The sponsor will be responsible for conducting inspections to ensure compliance with these specifications by the contractor.
4. The sponsor shall secure completion of the work in accordance with approved construction plans and specifications, and shall secure compliance with all Federal, State, and local laws and regulations.
5. In the event the project covered by the project agreement cannot be completed in accordance with the plans and specifications for the project, the sponsor shall bring the project to the point of recreational usefulness agreed upon by the sponsor and the Department.
6. The sponsor will provide for and maintain competent and adequate architectural engineering supervision and inspection at the construction site to ensure that the completed work conforms with the approved plans and specifications.
7. The sponsor shall furnish quarterly progress status reports to the Department beginning with the date of Parks & Wildlife Commission approval.
8. The sponsor will comply with the provisions of: Executive Order 11988, relating to evaluation of flood hazards; Executive Order 11288, relating to the prevention, control, and abatement of water pollution; Executive Order 11990, relating to the protection of wetlands; and the Flood Disaster Protection Act of 1973 (P.L. 93-234) 87 Stat. 975.
9. The sponsor will assist the Department in its compliance with the Texas Antiquities Code (Revised 9/1/87) by
 - (a) consulting with the Texas Antiquities Committee on the conduct of investigations, as necessary, to identify properties listed in or eligible for listing as State Archeological Landmarks, and to notify the Department of the existence of any such properties, and by
 - (b) complying with all requirements established by the Department to avoid or mitigate adverse effects upon such properties.

D. Construction Contracted for by the sponsor shall meet the following requirements:

1. Contracts for construction in excess of \$15,000 shall be awarded through a process of competitive bidding involving formal advertising, with adequate purchase description, sealed bids, and public openings. Copies of all advertisements, bids and a copy of the contract shall be provided the Department.
2. The sponsor shall inform all bidders on contracts for construction that TRPA funds are being used to assist in construction.
3. Written change orders shall be issued for all necessary changes in the facility being constructed. Such change orders shall be submitted to the Department for review and, if approved, shall be made a part of the project file and should be kept available for audit.
4. The sponsor shall incorporate, or cause to be incorporated, into all construction contracts the following provisions:

GENERAL PROVISIONS

TEXAS RECREATION & PARKS ACCOUNT PROGRAM PROJECT AGREEMENT

September 1994

Part I - Definitions

- A. The term "Department" as used herein means the Texas Parks & Wildlife Department or any representative delegated authority to act on behalf of the Department.
- B. The term "Project" as used herein means a single project which is the subject of this project agreement.
- C. The term "Sponsor" as used herein means the political subdivision which is party to the project agreement.
- D. The term "TRPA" as used herein means the Texas Recreation & Parks Account Program.
- E. The term "Procedural Guide" as used herein means the Procedural Guide for the Texas Recreation & Parks Account Program.

Part II - Continuing Assurances

The parties to the project agreement specifically recognize that the Texas Recreation & Parks Account assistance project creates an obligation to maintain the property described in the project agreement consistent with the Texas Recreation & Parks Account Procedural Guide, and the following requirements:

- A. The sponsor agrees that the property described in the project agreement and in the dated project boundary map made part of that agreement is being acquired or developed with TRPA assistance, and that it shall not be converted to other than public recreation use but shall be maintained in public recreation in perpetuity or for the term of the lease in the case of leased property.
- B. The sponsor agrees that the benefit to be derived by the State of Texas from the full compliance by the sponsor with the terms of this agreement is the preservation, protection, and the net increase in the quality of public recreation facilities and resources which are available to the people of the State, and such benefit exceeds to an immeasurable and unascertainable extent the amount of money furnished by the State by way of assistance under the terms of this agreement.
- C. The sponsor agrees that the property and facilities described in the project agreement shall be operated and maintained as prescribed by the Retention, Operation & Maintenance Responsibilities guidelines of the Procedural Guide.
- D. The sponsor agrees that a permanent record shall be kept and available for public inspection to the effect that the property described in the scope of the project agreement, and the dated project boundary map made part of that agreement, has been acquired or developed with TRPA assistance and that it cannot be converted to other than public recreation use.
- E. Nondiscrimination
 - 1. The sponsor shall comply with the terms of this agreement in the preservation, protection, and the net increase in the quality of public recreation facilities and resources which are available to the people of the State, and such benefit exceeds to an immeasurable and unascertainable extent the amount of money furnished by the State by way of assistance under the terms of this agreement.
 - 2. The sponsor shall comply with Title VI of the Civil Rights Act of 1964, which in part,
 - (a) prohibits discriminatory employment practices resulting in unequal treatment of persons who are or should be benefiting from the grant-aided facility.
 - (b) prohibits discriminating against any person on the basis of residence.

Part III - Project Assurances

A. Applicable Circulars

The State shall comply with applicable regulations, policies, guidelines and requirements including State Uniform Grant and Contract Management Act of 1981 (Revised 2/22/90), Federal Office of Management and Budget Circulars A-102 (Uniform administration requirements for grants-in-aid to State and Local governments), OMB A-87 (Cost principles applicable to grants and contracts with State and Local governments), and TRACS (Texas Review and Comment System) as they relate to the application, acceptance and use of State funds for grant assisted projects. It is the responsibility of the grant sponsor to have an A-128 Single Audit done annually for the project. When the sponsor receives \$25,000.00 or more in grant reimbursement per fiscal year. A copy of this audit will be furnished the Department within 30 days after completion of the sponsor's fiscal year audit.

4. The Department, State Comptroller of Public Accounts, State Auditors Office, or any of their duly authorized representatives, shall have access to any books, documents, papers, and records of the sponsor which are pertinent to a specific project for the purpose of making audits, examination, excerpts and transcripts.

I. Project Termination

1. The Department may temporarily suspend TRPA assistance under the project pending corrective action by the sponsor or pending a decision to terminate the grant by the Department.
2. The sponsor may unilaterally terminate the project at any time prior to the first payment on the project. After the initial payment, the project may be terminated, modified, or amended by the sponsor only by mutual agreement with the Department.
3. The Department may terminate the project in whole, or in part, at any time before the date of completion, whenever it is determined that the sponsor has failed to comply with the conditions of the grant. The Department will promptly notify the sponsor in writing of the determination and the reasons for termination, together with the effective date. Payments made to the sponsor or recoveries by the Department under projects terminated for cause shall be in accord with the legal rights and liabilities of the parties.
4. The Department or sponsor may terminate grants in whole, or in part, at any time before the date of completion, when both parties agree that the continuation of the project would not produce beneficial results commensurate with the further expenditure of funds. The two parties shall agree upon the termination conditions, including the effective date and, in the case of partial termination, the portions to be terminated. The sponsor shall not incur new obligations for the terminated portion after the effective date, and shall cancel as many outstanding obligations as possible. The Department may allow full credit to the sponsor for the State share of the non-cancelable obligations, properly incurred by the sponsor, pending written receipt of the determination and the reasons for termination, together with the effective date. Payments made to the sponsor or recoveries by the Department under projects terminated for cause shall be in accord with the legal rights and liabilities of the parties.
5. Termination either for cause or for convenience requires that the project in question be brought to a state of recreational usefulness agreed upon by the sponsor and the Department, or that all funds provided by the Department be returned.

J. Noncompliance

In the event that the sponsor does not comply with provisions as set forth in the grant contract agreement and Procedural Guide regarding both active project compliance and compliance at previously assisted grant sites, the following actions may be taken:

1. The Department may withhold payment to the sponsor;
2. The Department may withhold action on pending projects proposed by the sponsor;
3. If the above actions do not achieve program compliance, the Department may involve the State Attorney General's Office, pursuant to Section 24 of the Parks & Wildlife Code.

* * * * *

I have read the General Provisions and understand that the project sponsor which I represent will be responsible for compliance with the above conditions as a result of the receipt of grant assistance from the Texas Recreation & Parks Account Program. It is also understood that the General Provisions are part of the grant contract agreement.

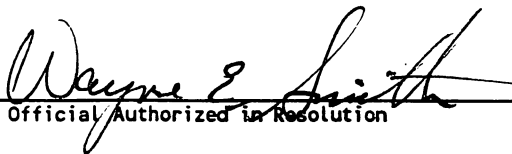

Signature of Official Authorized in Resolution

Wayne E. Smith
Terry Garnett, Mayor of Dripping Springs

(Name and Title)

7-17-98

(Date)

During the performance of this contract, the contractor agrees as follows:

"(1) The contractor will not discriminate against any employee or applicant for employment because of race, religion, color, gender, or national origin. The contractor will take affirmative action to ensure that applicants are employed, and that employees are treated during employment without regard to their race, religion, color, gender or national origin.

"(2) The Contractor will, in all solicitations or advertisements for employees placed by or on behalf of the contractor, state that all qualified applicants will receive consideration for employment without regard to race, religion, color, sex, or national origin."

"(3) The contractor will send to each labor union or representative of workers with which he has a collective bargaining agreement or other contract or understanding, a notice, to be provided by the agency contracting officer, advising the labor union or worker's representative of the contractor's commitments under Section 202 of Executive Order No. 11246, as amended (3 CFR 169 (1974), and shall post copies of notices in conspicuous places available to employees and applicants for employment."

"(4) The contractor will comply with all provisions of Executive Order No. 11246, as amended, and the rules, regulations, and relevant orders of the Secretary of Labor."

"(5) The contractor will furnish all information and reports required by Executive Order No. 11246, as amended, and by the rules, regulations, and order of the Secretary of Labor, or pursuant thereto, and will permit access to his books, records, and accounts by the contracting agency and the Secretary of Labor for purposes of investigation to ascertain compliance with such rules, regulations, and orders."

"(6) In the event of the contractor's noncompliance with the non-discrimination clauses of this contract or with any of such rules, regulations, or orders, this contract may be cancelled, terminated, or suspended in whole or in part and the contractor may be declared ineligible for further government contracts in accordance with procedures authorized in Executive Order No. 11246, as amended, and such other sanctions may be imposed and remedies invoked as provided in Executive Order 11246, as amended, or by rule, regulations, or order of the Secretary of Labor, or as otherwise provided by law."

"(7) The contractor will include the provisions of Paragraphs (1) through (7) in every subcontract or purchase order unless exempted by rules, regulations, or orders of the Secretary of Labor issued pursuant to Section 204 of Executive Order No. 11246, as amended, so that such provisions will be binding upon each subcontractor or vendor. The contract will take such action with respect to any subcontract or purchase order as the contracting agency may direct as means of enforcing such provisions, including sanctions for noncompliance: »Provided, however«, that in the event the contractor becomes involved in, or is threatened with, litigation with a subcontractor or vendor as a result of such direction by the contracting agency, the contractor may request the United States to enter into such litigation to protect the interests of the United States."

E. Conflict of Interests

1. No official or employee of the State or local government who is authorized in his official capacity to negotiate, make, accept, or approve, or to take part in such decisions regarding a contract or subcontract in connection with this project shall have any financial or other personal interest in any such contract.
2. No person performing services for the State or local government in connection with this project shall have a financial or other personal interest other than his employment or retention by the State or local government, in any contract or subcontract in connection with this project. No officer or employee of such interest is openly disclosed upon the public records of the State, and such officer, employee or person has not participated in the acquisition for or on behalf of the Participant.

F. Project Costs

Project Costs eligible for assistance shall be determined upon the basis of the criteria set forth by the TRPA Grants Manual.

G. Project Administration

1. The sponsor shall promptly submit such reports and documentation as the Department may request.

H. Retention and Custodial Requirements for Records

1. Financial records, supporting documents, statistical records, and all other records pertinent to this grant shall be retained for a period of three years after final payment; except the records shall be retained beyond the three-year period if audit findings have not been resolved.
2. The retention period starts from the date of the final expenditures report for the project.
3. Microfilm copies are authorized in lieu of original records.

SUMMARY OF ADMINISTRATION GUIDELINES (Continued)

3. Determinations as to whether the Department will award new grant funds to applicants having either active park grants or completed park grants will be based on the following criteria:
- All previously completed park grant projects must be in compliance with all the terms of the General Provisions of the contract agreement under which they received assistance and all applicable Land & Water Conservation Fund; Texas Local Parks, Recreation & Open Space Fund; and Texas Recreation & Parks Account Program Guidelines; and
 - For active grants, all required project documentation (such as appraisals, construction plans and specifications, quarterly status reports and reimbursement requests) must be complete and have been received on schedule, if due; and
 - All active projects which are at least two years old must be reimbursed for a minimum fifty percent of the approved grant amount; and
 - The total of approved grant funds which have not been reimbursed may not exceed \$1 million for all active grant projects.

FAILURE TO MEET ANY ONE OF THE ABOVE CRITERIA MAY BE GROUNDS FOR DENYING NEW GRANT FUNDS. ASSESSMENT OF THE ABOVE CRITERIA IN CONJUNCTION WITH REQUESTS FOR NEW GRANTS WILL BE MADE ON JUNE 1 FOR APPLICATIONS RECEIVED FOR THE JANUARY 31 SUBMISSION DEADLINE, AND ON NOVEMBER 1 FOR APPLICATIONS RECEIVED FOR THE JULY 31 SUBMISSION DEADLINE.

- Under extenuating circumstances Department staff may recommend new grant fund approval if a project sponsor has not met all of the above criteria. Grant award, however, may be contingent upon certain conditions which will be specified in staff recommendations to the Parks and Wildlife Commission.

* * * * *

I have read the Summary of Guidelines for Administration of Local Park Grant Assistance Projects and understand that the project sponsor which I represent will be responsible for compliance with the above conditions as a result of the receipt of grant assistance from the Texas Recreation & Parks Account. It is also understood that the Summary of Guidelines for Administration of Local Park Grant Assistance Projects are part of the grant contract agreement.

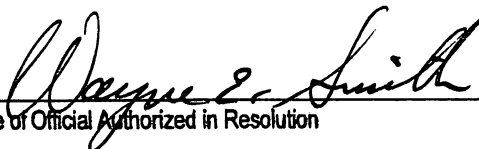

Signature of Official Authorized in Resolution

Wayne E. Smith
~~Terry Garnett~~, Mayor of Dripping Springs
Name and Title

7-17-98

Date

SUMMARY OF GUIDELINES

FOR ADMINISTRATION OF LOCAL PARK GRANT ASSISTANCE PROJECTS

July 1998

The Texas Parks & Wildlife Commission, by authority of Chapters 13 and 24 of the Parks & Wildlife Code, has adopted Guidelines for Administration of Local Park Grant Assistance Projects, to read as follows:

Policy. It is the Commission's policy that the Department shall administer local projects in accord with the following guidelines, with interpretation of intent to be made to provide the greatest number of public recreational opportunities for citizens of Texas. In keeping with this policy, local projects will not be approved from both the Texas Recreation & Parks Account and the Federal Land and Water Conservation Fund Program unless extraordinary circumstances dictate that high priority public needs will not be met without the full or partial funding of both programs.

1. Local administrative costs shall not be considered as eligible local matching funds unless circumstances dictate that high priority public needs will not be met without the full or partial benefit of such in-kind contribution.
2. Approved projects shall be pursued in a timely manner by the sponsor, unless delays result from extraordinary circumstances beyond the sponsor's control. Failure to meet the following time frames may be grounds for the Department to initiate cancellation of the affected project in order to recommend reallocation of available funds to other projects, or to deny requests for additional grant funds for new projects:

ACTIVITY	TIME FRAME
• Commission approval	Begin 3-year project period
• Pre-Contract Documentation (404 and/or Water Commission Permits, Cultural Resources Survey and Clearance, ROW Abandonment, Lease/Joint-Use Agreement execution)	Within 6 months after Commission approval
• Grant Agreement Execution	Within 6 months after Commission approval
• Quarterly Status Reports	Every 90 days after Commission approval
• Appraisal Approval	Within 6 months of grant agreement execution
• Land Acquisition	Within 9 months after appraisal approval
• Construction Plan Submission	Within 6 months of land acquisition for projects involving acquisition; or Within 6 months of contract execution for development only projects
• Periodic Reimbursement Billings	Every 90 days <u>if possible</u> (minimum \$10,000 request)
• Project Completion and Grant Close-Out	Within 3 years after Commission approval

DEAR SPONSOR:

THE ATTACHED DOCUMENTS ARE PART OF YOUR OFFICIAL PERMANENT PROJECT
FILE.

PLEASE RETAIN THE ATTACHED DOCUMENTS.

RETURN ONLY THOSE DOCUMENTS WHICH REQUIRE SIGNATURES.

THANK YOU.

TABULAR SUMMARY

PROJECT: DRIPPING SPRINGS RECREATIONAL COMPLEX	REIMBURSEMENT REQUEST NO.
PROJECT NUMBER: 50-00162	PERIOD COVERED:

		ESTIMATE	COMPLETED LAST REQUEST	COMPLETED THIS PERIOD	TOTAL COMPLETE
1. <u>PROFESSIONAL SERVICES</u>					
Begin: 7-31-97	\$	62,000.00			
2. <u>CONSTRUCTION ELEMENTS</u>					
A. Recreational Facilities					
1. Baseball field		140,000.00			
2. Softball field		130,000.00			
3. Soccer fields (4)		120,000.00			
4. Covered multi-purpose court		55,000.00			
5. Volleyball court		20,000.00			
6. Ropes Course		21,250.00			
7. Playscape		21,000.00			
8. Nature trail (1.1 miles)		22,000.00			
9. Horseshoe pits (4)		2,000.00			
10. Washer pits (4)		2,000.00			
11. Picnic tables (22)		20,000.00			
12. Benches (20)		10,000.00			
13. Wildscape garden		2,000.00			
14. Interpretive kiosk		2,000.00			
B. Miscellaneous					
1. Xeriscaping		7,500.00			
2. Signs		500.00			
Construction Cost	\$	575,250.00			
Less Retainage	\$	0.00			
TOTAL CONSTRUCTION	\$	575,250.00			
3. <u>LAND: 37 acres (by donation)</u>	\$	166,500.00			
<u>Appraisals/bound survey</u>		5,000.00			
TOTAL PROJECT COST	\$	808,750.00			

MATCH: \$404,375.00

DRIPPING SPRINGS RECREATIONAL COMPLEX

Project Number 50-00162

ACQUISITION SCHEDULE

Code*	Parcel Number	Acreage	Estimated Value of Land	Estimated Value of Improvements	Current Owner	Total Estimated Cost/Parcel
3	1	37	\$166,500.00	\$0.00	Dripping Springs ISD	*** \$166,500.00
Total Acreage		37	Total Estimated Cost			\$166,500.00

- Acquisition Codes:
- 1 = By Negotiated Purchase
 - 2 = By Eminent Domain/Condemnation
 - 3 = By Donation
 - 4 = Publicly Owned Non-Parkland

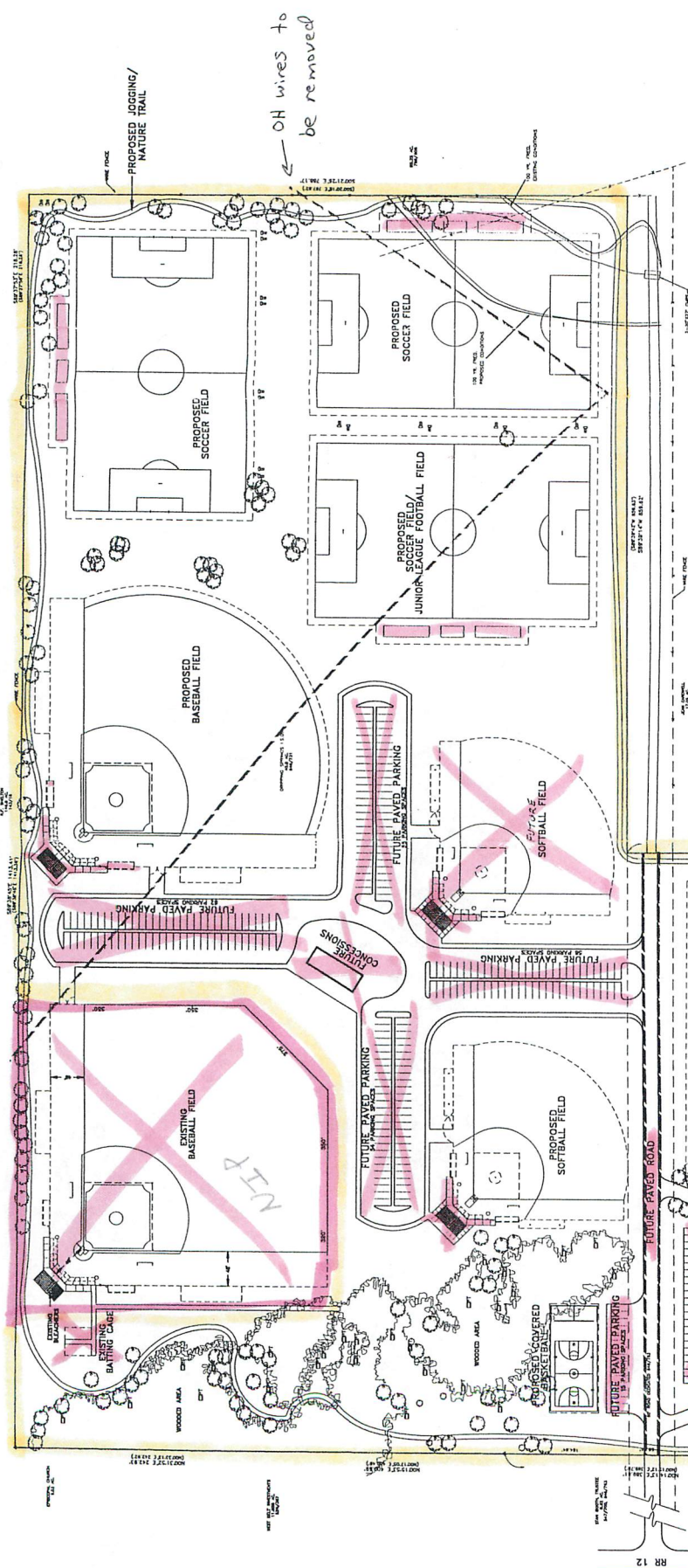

OH wires to be removed

THE CITY OF DRIPPING SPRINGS RECREATION COMPLEX
 TEXAS PARKS & WILDLIFE DEPARTMENT
 RECREATION GRANTS BRANCH
 OFFICIAL SITE PLAN/BOUNDARY MAP
 SPONSOR Dripping Springs
 PROJECT Recreational Complex
 PROJECT NO. 50-162 TYPE A D
 ACQUISITION AREA
 PROJECT AREA
 LEASE EXPIRATION DATE 4/1
 NOT IN PROJECT DATE 1-22-98

SCALE: 1" = 100'-0"
 LEGEND
 B PROPOSED PARK BENCH
 CPT PROPOSED PICNIC TABLE
 6.1 acres
 PROPOSED open space area

16' Road easement - EXISTING
 Overhead Utility Lines - EXISTING
 To be moved

RR 12

BRIGGS
 ENGINEERS
 JULY 28, 1987

SITE PLAN

**RESOLUTION
99-1**

WHEREAS, The City of Dripping Springs owns the property called the Dripping Springs Sports and Recreation Complex;

WHEREAS, the City of Dripping Springs submitted a Master Plan for the Dripping Springs Sports and Recreation Complex to the Texas Parks and Wildlife Department (Project Number 50-00162);

WHEREAS, the Master Plan for the Dripping Springs Sports and Recreation Complex contains 2.10 acres of open space;

NOW THEREFORE BE IT RESOLVED BY THE CITY COUNCIL OF THE CITY OF DRIPPING SPRINGS, TEXAS:

The 2.10 acres of open space, as shown in the Master Plan for the Dripping Springs Sports and Recreation Complex, is dedicated as open space henceforth and in perpetuity.

PASSED, APPROVED AND ADOPTED this 8th day of December, 1998.

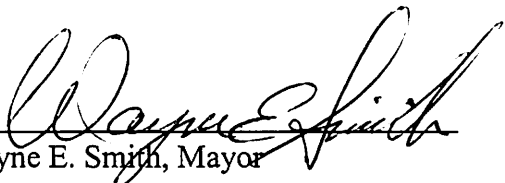

Wayne E. Smith, Mayor

ATTEST:

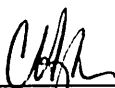

Christine Harrington, City Secretary



METES AND BOUNDS DESCRIPTION

BEING 2.1012 ACRES OF LAND OUT OF THE P.A. SMITH LEAGUE AND BEING A PORTION OF A 40.0 ACRE TRACT OF LAND CONVEYED TO DRIPPING SPRINGS INDEPENDENT SCHOOL DISTRICT BY DEED OF RECORD IN VOLUME 646, PAGE 731 OF THE OFFICIAL PUBLIC RECORDS OF HAYS COUNTY, TEXAS AND BEING MORE PARTICULARLY DESCRIBED BY METES AND BOUNDS AS FOLLOWS:

BEGINNING at a 1/2" rebar with plastic cap found for the most southerly southeast corner of said 40.0 acre tract and also being the southwest corner of a 17.05 acre tract of land conveyed to Jean-Claude P. and Mara R. Cardwell by Warranty Deed with Vendor's Lien, of record in Volume 797, Page 709 of the Real Property Records of Hays County, Texas and in the north line of a 82.02 acre tract of land conveyed to Lawrence Karger by Deed of record in Volume 762, Page 382 of the Official Public Records of Hays County, Texas and also being in the north line of a 30 foot wide ingress-egress easement, of record in Volume 181, Page 171 of the Deed Records of Hays County, Texas;

THENCE North 89°48'12" West along the south line of the 40.0 acre tract and the north line of said 82.02 acre tract and said 30 foot wide easement a distance of 788.16 feet (record: North 89°47' West, 788.23 feet) to a 1/2" iron pipe found for the southwest corner of the 40.0 acre tract, being in the north line of the 82.02 acre tract and being the southeast corner of a 2.50 acre tract of land conveyed to Diane L. Bonham by deed of record in Volume 360, Page 405 of the Official Public Records of Hays County, Texas;

THENCE North 00°22'02" East, along the west line of the 40.0 acre tract and the east line of said 2.50 acre tract a distance of 289.49 feet to a calculated point, from which a 3/4" iron pipe found for the northeast corner of the 2.50 acre tract and the southeast corner of a 8.82 acre tract of land conveyed to Stan Booth, Trustee by Warranty Deed with Vendor's Lien, of record in Volume 646, Page 763 and amended in an Amendment to Deed of Trust, of record in Volume 547, Page 700, both of the Deed Records of Hays County, Texas bears North 00°22'02" East a distance of 37.03 feet;

THENCE crossing through the 40.0 acre tract the following five (5) courses:

1. South 89°48'12" East a distance of 59.27 feet to a calculated point;
2. South 00°22'02" West a distance of 224.86 feet to a calculated point;
3. South 89°48'12" East a distance of 500.57 feet to a calculated point;
4. North 00°20'46" West a distance of 119.97 feet to a calculated point;
5. South 89°48'12" East a distance of 227.51 feet to a calculated point in the east line of the 40.0 acre tract and in the west line of said 17.05 acre tract of land, from which a 1/2" rebar found for a southerly corner of the 40.0 acre tract and the northwest corner of said 17.05 acre tract bears North 00°20'46" West a distance of 314.24 feet;

THENCE South 00°20'46" East along the east line of the 40.0 acre tract and the west line of the 17.05 acre tract a distance of 184.60 feet to the POINT OF BEGINNING.

N-CLAUDE P. & MARA R. CARDWELL

17.05 AC.

VOL. 797 PG. 709

(N00°20'18"W 558.85')

N00°20'46"W 558.85'

314.24'

S00°20'46"E

184.60'

POINT OF BEGINNING

NORTH

SCALE IN FEET

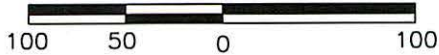

LEGEND

- 1/2" REBAR FOUND
- △ CALCULATED POINT
- ⊙ IRON PIPE FOUND (DIAMETER NOTED)

OPEN SPACE EASEMENT
2.1012 AC.

S89°48'12"E

227.51'

N00°20'46"W

119.97'

30' INGRESS-EGRESS EASEMENT VOL. 181 PG. 1717

LAWRENCE KARGER
82.02 AC.
VOL. 762 PG. 382

P. A. SMITH LEAGUE

DRIPPING SPRINGS I.S.D.

40.0 AC.

VOL. 646 PG. 731

S89°48'12"E

500.57'

(N89°47'W 788.23')

N89°48'12"W 788.16'

S00°22'02"W

224.86'

37.03'

S89°48'12"E

59.27'

N00°22'02"E 289.49'

N00°14'13"E 389.61'
(N00°15'12"E 389.76')

STAN BOOTH, TRUSTEE
8.82 AC.
VOL. 547 PG. 700
VOL. 646 PG. 763

(N00°23'25"E 326.37')
N00°22'02"E 326.52'

DIANE L. BONHAM
2.50 AC.
VOL. 360 PG. 405

BEARING BASIS: ALL BEARINGS ARE BASED ON THE NORTH LINE OF THE 40.0 ACRE TRACT OF LAND CONVEYED TO DRIPPING SPRINGS INDEPENDENT SCHOOL DISTRICT BY DEED OF RECORD IN VOL. 646, PAGE 731 OF THE REAL PROPERTY RECORDS OF HAYS COUNTY, TEXAS BEING SOUTH 89°38'45" EAST.

ATTACHMENTS: METES AND BOUNDS DESCRIPTION N:\MSAPPS97\WORD\SUR\9401204.FN

I HEREBY CERTIFY THAT THIS SURVEY WAS MADE ON THE GROUND ON THE PROPERTY SHOWN HEREON DURING NOVEMBER 1998 UNDER MY DIRECTION AND SUPERVISION AND IS TRUE AND CORRECT TO THE BEST OF MY KNOWLEDGE.



Ron Wallace 18 Nov 98

RONNIE WALLACE DATE
REGISTERED PROFESSIONAL LAND SURVEYOR
STATE OF TEXAS NO. 5222

File: N:\SDSK\SUR\9401204.DWG

Issue Date: 11/18/98 Job No. 410-98002

Field Book No. Pg. Scale: 1"=100'

Drawn By: RLW Checked By: JLB

SKETCH TO ACCOMPANY
METES AND BOUNDS
DESCRIPTION



K.C. ENGINEERING, INC.
CONSULTING ENGINEERS AND SURVEYORS

4601 SOUTH LAMAR BLVD., SUITE 230 AUSTIN, TEXAS 78745
OFFICE: (512) 892-5585 FAX (512) 892-5586

This parcel contains 2.1012 acres of land, more or less, out of the P.A. Smith League in Hays County, Texas. Description prepared from an on-the-ground survey made during November 1998.

Ron L. Wallace 18 Nov. 98
Ronnie Wallace Date
Registered Professional Land Surveyor
State of Texas No. 5222



Job Number: 410-98002

Attachments: Survey Drawing N:\SDSK\SUR\9401204.DWG

File: N:\MSAPPS97\WORD\SUR\9401204.FN

