

CERTIFICATE OF OWNERSHIP AND DEDICATION

I, HEREBY CERTIFY THAT I AM THE OWNER OF THE PROPERTY SHOWN AND DESCRIBED HEREON; THAT I APPROVE THIS SURVEY AND PLAT AND DEDICATE TO THE PUBLIC ALL EASEMENTS FOR PUBLIC UTILITIES, ROADWAYS, ALLEYS AND OTHER PUBLIC AREAS SHOWN HEREON.

CAMERON POINDEXTER, PRESIDENT & CEO
 CHOGGIUNG INVESTMENT COMPANY, LLC
 PO BOX 330
 DILLINGHAM, ALASKA 99576

DATE

NOTARY ACKNOWLEDGMENT

SUBSCRIBED AND SWORN TO BEFORE ME THIS ____ DAY OF _____, 2024.

PERSONALLY APPEARING BEFORE ME.

NOTARY PUBLIC FOR ALASKA

MY COMMISSION EXPIRES

LEGEND

- FOUND MONUMENT AS NOTED
- MONUMENT SET THIS SURVEY
- (M) MEASURED
- (C) COMPUTED
- (H) HELD
- (HRR) HELD RECORD RADIUS
- (P) PROPORTIONED
- BBRD BRISTOL BAY RECORDING DISTRICT
- (R1) RECORD DATA PER PLAT NO. 77-3, BBRD
- (R2) RECORD DATA PER U.S.S. NO. 3643
- (R3) RECORD DATA PER PLAT NO. 81-2, BBRD
- SUBDIVISION BOUNDARY
- INTERIOR LOT LINE
- ADJACENT PROPERTY LINE
- RIGHT-OF-WAY CENTERLINE
- EASEMENT LINE
- ▬ BUILDING OUTLINE

TYPICAL MONUMENT SET THIS SURVEY

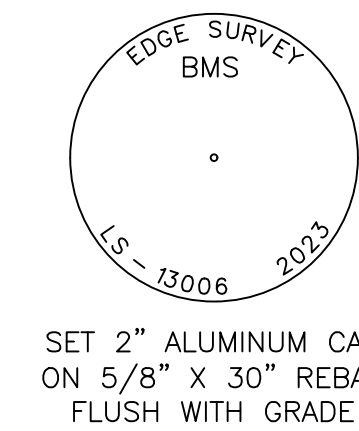

NOTES

- THE BASIS OF BEARING FOR THIS PLAT IS BASED ON THE FAIRVIEW SUBDIVISION, PLAT NO. 77-3, IN THE BRISTOL BAY RECORDING DISTRICT.
- THERE SHALL BE A 30' SHARED ACCESS EASEMENT CENTERED ON THE COMMON LINE BETWEEN LOTS 1 & 2 DEDICATED BY THE PLAT AND SHOWN HEREON.
- NO INDIVIDUAL WATER SUPPLY SYSTEM OR SEWAGE DISPOSAL SYSTEM SHALL BE PERMITTED ON ANY LOT UNLESS THE SYSTEM IS LOCATED, CONSTRUCTED AND EQUIPPED IN ACCORDANCE WITH THE REQUIREMENTS, STANDARDS AND RECOMMENDATIONS OF THE STATE OF ALASKA, DEPARTMENT OF ENVIRONMENTAL CONSERVATION, WHICH GOVERNS THOSE SYSTEMS.
- WASTEWATER DISPOSAL SYSTEMS SHALL COMPLY WITH ADEC REGULATIONS.
- BY GRAPHIC PLOTTING ONLY, THIS PROPERTY DOES NOT LIE WITHIN A SPECIAL FLOOD HAZARD AREA AS DETERMINED BY THE FEDERAL EMERGENCY MANAGEMENT AGENCY; THIS PROPERTY IS IN ZONE C AN AREA OF MINIMAL FLOODING; FLOOD INSURANCE RATE MAP NO. 0200410017B BEARING AN EFFECTIVE DATE OF SEPTEMBER 30, 1982 WAS USED TO DETERMINE THE FLOOD ZONE. EXACT DESIGNATION CAN ONLY BE DETERMINED BY AN ELEVATION CERTIFICATE.
- THERE MAY BE FEDERAL, STATE, OR LOCAL REQUIREMENTS GOVERNING LAND USE. THE INDIVIDUAL PARCEL OWNER SHALL OBTAIN A DETERMINATION WHETHER THESE REQUIREMENTS APPLY TO THE DEVELOPMENT OF PARCELS SHOWN ON THIS PLAT.

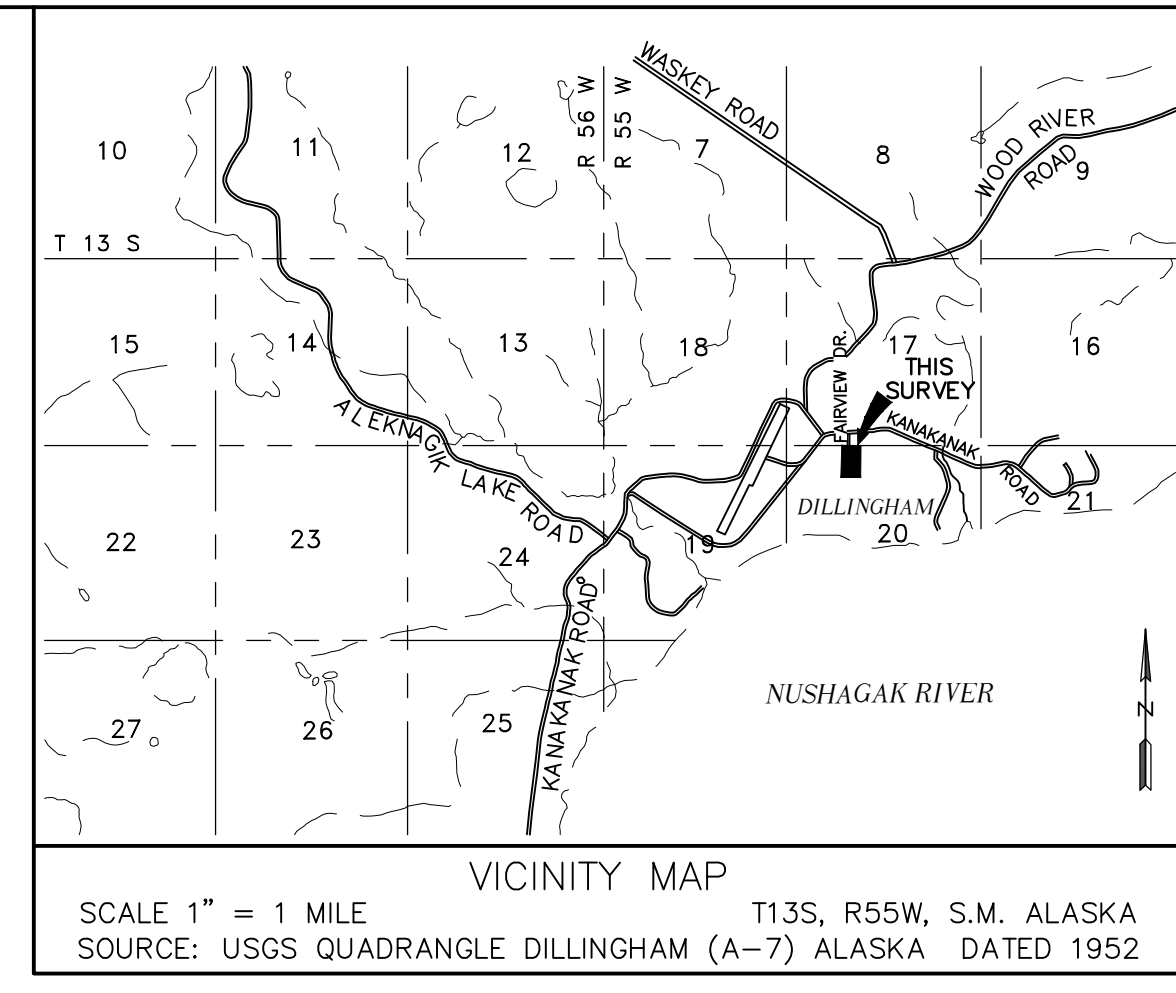
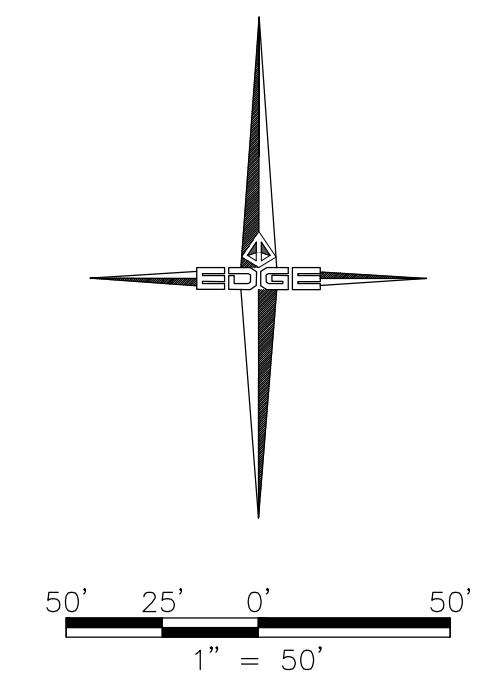
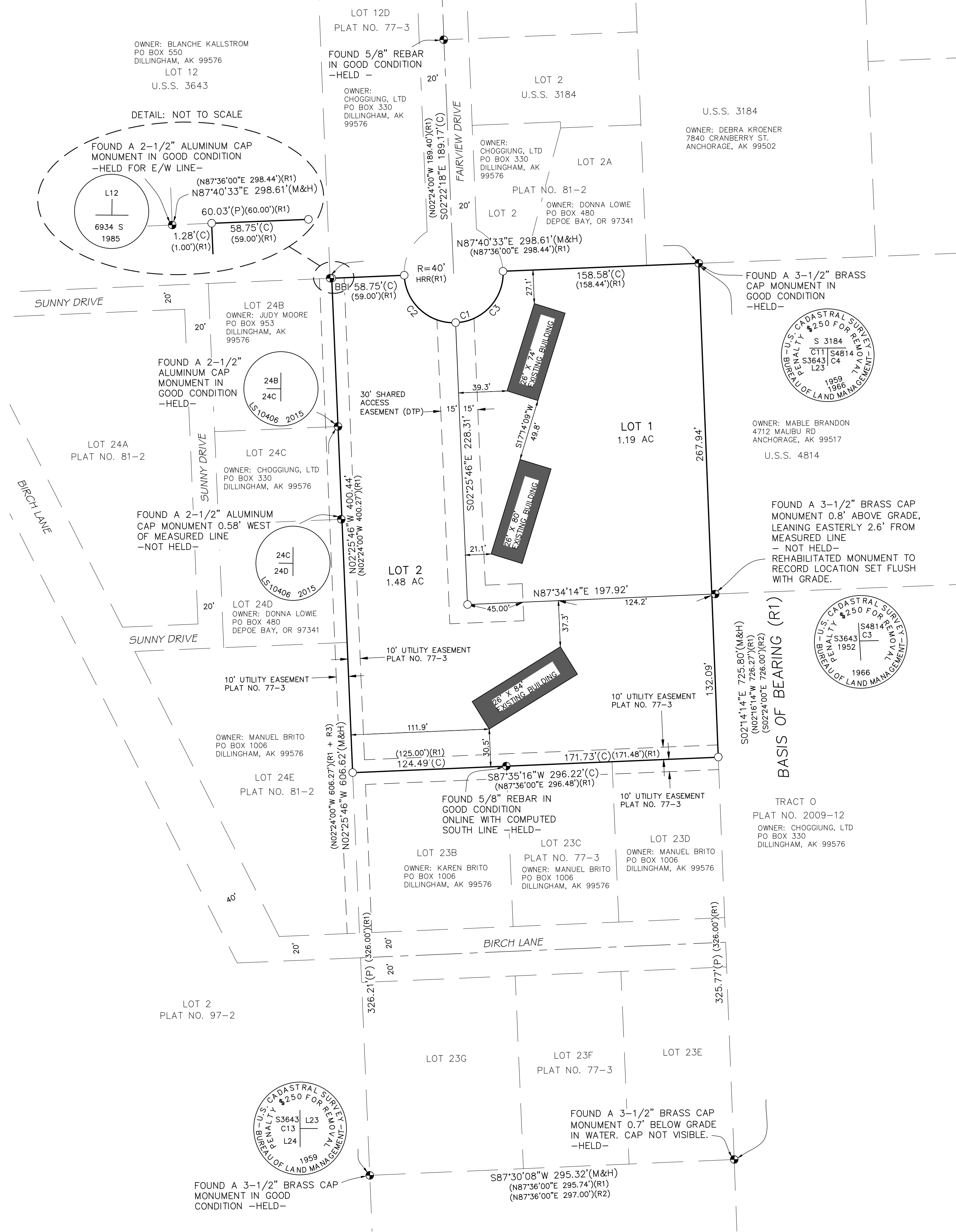

Curve Table

CURVE #	RADIUS	DELTA	LENGTH	CHORD DIRECTION	CHORD LENGTH
C1(HRR) (R1)	40.00' 40.00'	180°00'00" 180°00'00"	125.66' 125.66'	N87°40'33"E 125.66'	80.00'
C2	40.00'	90°00'00"	62.83'	S47°19'27"E	56.57'
C3	40.00'	90°00'00"	62.83'	N42°40'33"E	56.57'

PLAT APPROVAL

THIS PLAT HAVING BEEN APPROVED BY THE DILLINGHAM PLANNING COMMISSION AS RECORDED IN THE OFFICIAL MINUTES OF THE MEETING OF _____, 2023 IS HEREBY ACKNOWLEDGED AND ACCEPTED AS THE OFFICIAL PLAT SUBJECT TO ANY AND ALL CONDITIONS AND REQUIREMENTS OF ORDINANCES AND LAW APPEARING THERETO.

PRESIDING OFFICER—PLANNING COMMISSION _____ DATE _____

ACCEPTANCE OF DEDICATION

THE CITY OF DILLINGHAM HEREBY ACCEPTS FOR PUBLIC USES AND FOR PUBLIC PURPOSES THE REAL PROPERTY DEDICATED ON THIS PLAT, INCLUDING, BUT NOT LIMITED TO THE REAL PROPERTY, RIGHTS-OF-WAY AND EASEMENTS FOR PUBLIC UTILITIES, STREETS, ALLEYS, THOROUGHFARES, TRAILS, PARKS AND OTHER PUBLIC AREAS SHOWN HEREON.

ALICE RUBY, MAYOR _____ DATE _____

CITY CLERK _____ DATE _____

SURVEYOR'S CERTIFICATE

I, RYAN E. SORENSEN, HEREBY CERTIFY THAT I AM PROPERLY REGISTERED AND LICENSED TO PRACTICE LAND SURVEYING IN THE STATE OF ALASKA, THAT THIS PLAT REPRESENTS A SURVEY MADE BY ME OR UNDER MY DIRECT SUPERVISION, THAT THE MONUMENTS SHOWN HEREON ACTUALLY EXIST AS DESCRIBED, AND THAT ALL DIMENSIONS AND OTHER DETAILS ARE CORRECT.

DATE: _____

RYAN E. SORENSEN, R.L.S. 13006-S

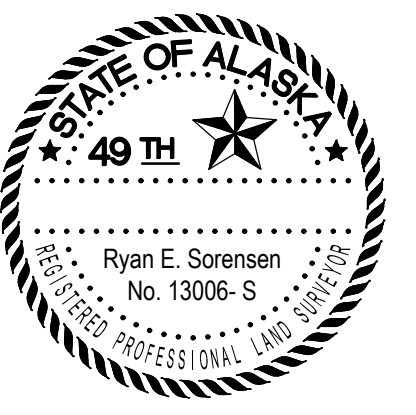

A PLAT OF
BINGMAN SUBDIVISION
 A SUBDIVISION OF LOT 23A
 FAIRVIEW SUBDIVISION
 PER PLAT NO. 77-3

LOCATED WITHIN
 SECTION 20, T13S, R55W, S.M. AK
 BRISTOL BAY RECORDING DISTRICT, THIRD JUDICIAL DISTRICT
 DILLINGHAM, ALASKA
 CONTAINING 2.67 ACRES

DRAWN BY: VLB DATE: 11/17/2023	SURVEY DATE: 08/7/2023	PROJECT #: 23-550
CHECKED BY: RS	SCALE: 1"=50'	SHEET 1 OF 1