

CD40 THIN LINE CONTROL DAMPER EXTRUDED ALUMINUM

STANDARD CONSTRUCTION

FRAME

4" x 1" (102 x 25) x 6063T5 extruded aluminum hat channel with .081" (2) minimum wall thickness. Mounting flanges on both sides of frame.

BLADES

4" (102) wide, 6063T5 heavy gage extruded aluminum, airfoil shaped blades.

LINKAGE

Concealed.

AXLES

1/2" (13) plated steel hex.

BEARINGS

Molded synthetic.

SEALS

Extruded TPR blade edge seal for -72°F to +275°F (-58°C to +135°C) and flexible metal compression type jamb seals.

CONTROL SHAFT

6" x 1/2" (152 x 13) diameter. Outboard support bearing supplied with all single section dampers for field mounted actuators. Factory-installed jackshaft supplied with all multiple section dampers.

FINISH

Mill.

MINIMUM SIZE

Single blade, parallel action – 6"w x 6"h (152 x 152).
Two blade, parallel or apposed action – 6"w x 9"h (152 x 229).

MAXIMUM SIZE

Single section – 60"w x 72"h (1524 x 1829).
Multiple section assembly – Unlimited size.

NOTE:

- 1) CD40 is not recommended for installation with blades running vertically unless unit is furnished without side seals.
- 2) If damper is to be used in a fan discharge application, consult Ruskin.

Dimensions shown in parenthesis () indicate millimeters.

*Units furnished approximately 1/4" (6) smaller than given opening dimensions.

**Jackshaft used only on multiple section dampers.

FEATURES

The CD40 combines the lowest leakage attainable – 6 cfm/sq. ft. at 4" w.g. – with thin line, 4" (102) overall depth when damper is completely open. Damper easily butts to back side of a louver to tight shut-off capability.

Unique double edge blade seal design features inflatable pocket that enables higher pressure on either side of damper to assist in blade-to-blade seal off. Seals are mechanically locked in extruded blade slots yet can be easily replaced in the field.

Linkage is concealed out of airstream for low maintenance and reduced air turbulence. Hexagonal axles positively lock with blades.

VARIATIONS

Variations to standard design are available at additional cost. They include:

- Anodize finishes.
- Factory-installed, pneumatic and electric actuators (specific information required with order).
- Frame-mounting bracket for simple field installation of most actuators.
- SP100 Switch Package to remotely indicate damper blade position.
- Front or rear flange frame.
- Face and bypass mixing damper assemblies (see page 2).

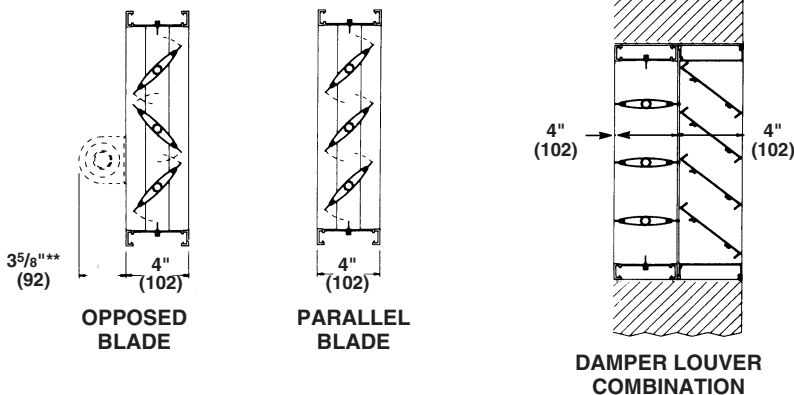
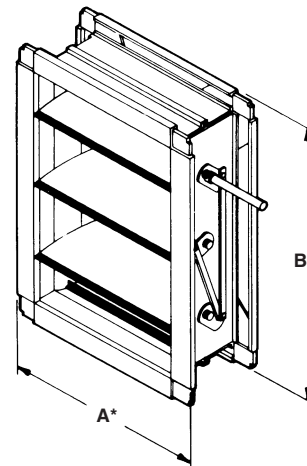

FACE and BYPASS MIXING DAMPERS

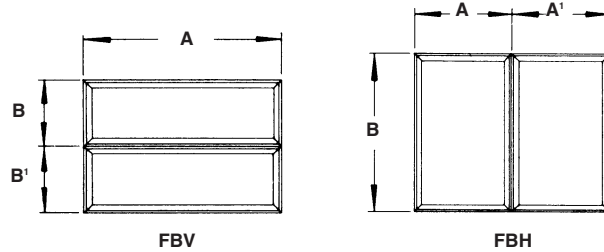
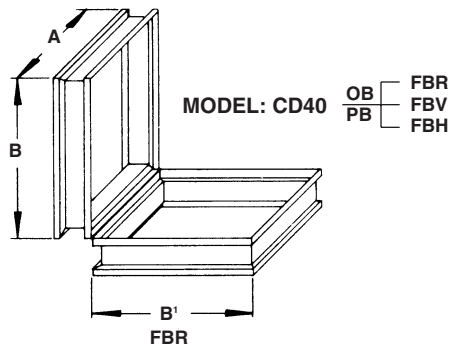

Dampers larger than maximum single section are an assembly of equal size single section dampers (maximum section size 48" w x 72" h (1219 x 1829) and may be coupled for operation in a variety of ways. A 1" (25) diameter jackshaft is normally used for multiple section coupling.

Larger multiple section damper assemblies require an analysis of how the damper is to be operated (how many and what type of actuators) before the best method of coupling sections can be determined. Special assembly drawings are normally prepared and forwarded for customer review on larger damper assemblies.

Examples: A 72" x 60" (1829 x 1524) damper would be an assembly consisting of two 36" x 60" (914 x 1524) damper sections.

A 102" x 100" (2591 x 2540) damper would be an assembly consisting of six 34" x 50" (864 x 1270) damper sections.

SUGGESTED SPECIFICATION

Furnish and install, at locations shown on plans, or in accordance with schedules, low leakage dampers that meet the following minimum construction standards: Frames shall be 4" x 1" x .081" (102 x 25 x 2) (minimum thickness) 6063T5 extruded aluminum hat channel with hat mounting flanges on both sides of the frame. Each corner shall be reinforced with two die formed internal braces and machine staked for maximum rigidity. Blades shall be airfoil type extruded aluminum (maximum 4" [102] depth) with integral structural reinforcing tube running full length of each blade.

Blade edge seals shall be extruded vinyl double edge design with inflatable pocket which enables air pressure from either direction to assist in blade to blade seal off. Blades seals shall be mechanically locked in extruded blade slots, yet shall be easily replaceable in field. Adhesive or clip-on type blade seals are not acceptable. Bearings shall be non-corrosive molded synthetic. Axles shall be hexagonal (round not acceptable) to provide positive locking connection to blades and linkage. Linkage shall be concealed in frame. Dampers shall be in all respects equivalent to Ruskin Model CD40.

RUSKIN[®]

3900 Dr. Greaves Rd.
Kansas City, MO 64030
(816) 761-7476
FAX (816) 765-8955
www.ruskin.com