

**Request for Bids
For Elevator Modernization/ Cab-Entrance
Replacement - 2024**

Broadway Parking Structure Passenger Elevator

**BID OPENING:
April 10, 2024-----2:00 P.M.**

**SINGLE POINT OF CONTACT AND PROJECT POINT
OF CONTACT**

**Justin Lux
Parking & Transportation
(605) 578-2082
justin@cityofdeadwood.com**

**Request for Bids
For Elevator Modernization/ Cab-Entrance Replacement**

Broadway Parking Structure Passenger Elevator

Introduction

The City of Deadwood (COD) in Deadwood, South Dakota is requesting proposals for the modernization and cab-entrance replacement of a passenger elevator located in the Broadway Parking Structure at 630 Broadway Avenue, Deadwood, South Dakota 57732.

Background

The Broadway Parking Structure was constructed in 1996. It has four levels serviced by three sets of stairs. It is serviced by one elevator on the northeast corner of the structure. It is a cement structure with a brick veneer. The Broadway Parking Structure facilitates parking for approximately 90,000 vehicles annually.

This RFP is divided into the following sections:

Introduction

Background

Call for Bids

General Provisions

Bid Form

General Specifications

Original Design Documents

Call for Bids

Each bid shall be submitted on the bid form in this packet with required appendices. The following elements must be included in each bid:

1. Qualified individuals or firms are invited to submit their bid in writing to the Single Point of Contact (SPOC) for this solicitation:

Contact: Justin Lux
City of Deadwood
Parking & Transportation
Address: Director
108 Sherman St
Phone: Deadwood SD 57732
Email: 605-578-2082
justin@cityofdeadwood.com

Please address the bid to the SPOC above and title your email as: ***RFB Response – Broadway Ramp Elevator Modernization/Cab-Entrance Replacement***

2. Bids must be received to the COD by the 2:00 pm on April 10, 2024 specified.
3. No Bid will be considered which is not submitted on the attached Bid Form, signed by a proper official of the company bidding, in the space provided
4. No Bid will be considered which modifies in any manner any of the general provisions, specifications, or the bid form.
5. A Bid that is in the possession of the COD may be altered, provided it is received prior to the time and date of the bid opening. It is the bidder’s responsibility to confirm receipt of this alteration by the SPOC.
6. A Bid that is in the possession of the SPOC may be withdrawn by the bidder up to the time and date of the bid opening. Bids may not be withdrawn for a period of 30 days after the bid opening.
7. A formal contract will be issued, and the work contemplated will be covered by a SERVICE CONTRACT.
8. Acceptance of the SERVICE CONTRACT will be deemed to mean acceptance of the contract work as specified in the Bid.
9. Payments will be made monthly for completed progress for that period.
10. Final payment will be made after the acceptance of all work.

11. Failure of the successful bidder to furnish the equipment, materials, supplies, or perform the service awarded from their Bid shall assume forfeiture of the bid bond.
12. COD hereby notifies all prospective bidders that COD will affirmatively assure that minority business enterprises will be afforded full and equal opportunity to submit bids in response to this invitation and are specifically encouraged to do so. COD further assures that it will not discriminate against anyone on the grounds of race, sex, age, color or national origin or disability in consideration for an award.
13. A Pre-bid Site Walkthrough is not scheduled; however, additional information can be requested via email from the SPOC and will be shared with all prospective bidders according to the Project Timeline and Schedule.

Project Timeline and Schedule:

March 18, 2024	Advertise Bids
April 1, 2024	Deadline for request for clarifications/questions
April 10, 2024	Bid submission deadline
April 15, 2024	Anticipated award announcement
May 6, 2024	Contract signed
May 7, 2024	Notice to Proceed
September 30, 2024	Substantial Completion

General Provisions: Broadway Ramp Elevator Modernization/ Cab-Entrance Replacement

1. LICENSES, PERMITS AND TAXES:

The Contractor shall procure all permits and licenses, pay all charges, fees and taxes, and give all notices necessary and incidental to the due and lawful prosecution of the work.

2. LAWS TO BE OBSERVED:

The Contractor shall be kept fully informed on all Federal and State laws, all local bylaws, regulations, ordinances and decrees of bodies or tribunals having any jurisdiction or authority which in any manner affects those engaged or employed on the work, or which in any way affects the conduct of the work. They shall at all times observe and comply with all such laws, bylaws, ordinances, regulations, orders and decrees in force at the time of award. The Contractor shall protect and indemnify COD and its representatives against any claim or liability arising from or based on the violation of any such law, bylaw, ordinance, regulation, order of decree whether by themselves or their employees. No extension of time or additional payment will be made for loss of time or disruption of work caused by any actions against the Contractor for any of the above reasons.

3. CONTRACTOR'S INSURANCE:

- a. The Contractor shall not commence work under this contract until they have obtained all the insurance required hereunder and such insurance has been approved by COD. Approval of the insurance by COD shall not relieve or decrease the liability of the Contractor. The Contractor shall file a Certificate of Insurance with COD, verifying each type of coverage required including a certificate of insurance specifically naming COD as additionally insured.

- i. Workers' Compensation and Employer's Liability Insurance. The Contractor shall provide proof of workers' compensation coverage for all its employees who are to work on the project described in this Contract. Contractor's coverage shall be under the South Dakota Workers' Compensation program, if statutorily required, or such workers' compensation insurance as appropriate. The Contractor shall also supply to COD proof of workers' compensation and employers' liability insurance, if required, on each and every subcontractor prior to allowing that subcontractor on the job site.
- ii. Commercial General Liability Insurance. The Contractor shall provide coverage, during the entire term of this contract, against claims arising out of bodily injury, death, damage to or destruction of the property of others, including loss of use thereof, and products and completed operations, in an amount not less than One Million Dollars (\$1,000,000) per occurrence.
- iii. Business Automobile Liability Insurance. The Contractor shall maintain, during the entire term of the contract, automobile liability insurance in an

amount not less than Five Hundred Thousand Dollars (\$500,000) per occurrence.

- iv. Unemployment Insurance. The Contractor shall be duly registered with the Employment Security Commission, Unemployment Compensation Division. The Contractor shall supply an Official notice of Unemployment Insurance Coverage for itself and on each and every subcontractor prior to beginning work under this contract.
 - v. Certificate of Good Standing. The Contractor shall provide a Certificate of Good Standing verifying compliance with the unemployment insurance and workers' compensation programs prior to performing work under this Contract.
 - vi. Payment of Premiums and Notice of Revocation. All policies required under this Contract shall be in effect for the duration of this Contract and project. All policies shall be primary and not contributory. Contractor shall pay the premiums on all insurance certificates which must include a clause stating that the insurance may not be revoked, canceled, amended, or allowed to lapse until the expiration of at least thirty (30) days advance written notice to COD.
 - vii. COD May Insure for Contractor. In case of the breach of any provision of this Section, COD may, at COD's option, purchase and maintain, at the expense of the Contractor, such insurance in the name of the Contractor, or subcontractor, as COD may deem proper and may deduct the cost of taking out and maintaining such insurance from any sums which may be found to be due or become due to the Contractor under this Contract.
- b. **COD's right to reject:** COD reserves the right to reject a certificate of insurance if the Contractor's insurance company is widely regarded in the insurance industry as financially unstable. This includes, but is not limited to, insurance companies with an "Omit" rating in the A.M. Best insurance rating guide.
- c. **COD's right to contact insurer:** COD shall have the right to consult with the Contractor's insurance agent for disclosure of relevant policy information. Relevant information includes, but is not limited to:
- i. Exclusions endorsed;
 - ii. Claims in progress which could significantly reduce the annual aggregate limit;
 - iii. If the policy is a "claims made" policy instead of an "occurrence" policy, the information provided shall include, but not necessarily be limited to:
 - 1. Retroactive dates;
 - 2. Extended reporting periods or tails; and

3. Any applicable deductibles.

4. PRE-BID MEETING:

Before submitting, the Contractor should familiarize themselves as best as possible with the area and the conditions affecting the work. A Pre-bid Site Walkthrough is not planned; however, additional information can be requested via email from SPOC and will be shared with all prospective bidders according to the Project Timeline and Schedule.

5. CONTRACT TIME:

Said work shall commence upon receipt of the Notice to Proceed and shall be completed by September 30, 2024. Concept of the work is to start within and conveyed to COD and to progress without interruption until the job is complete.

6. EXTRA WORK:

In consultation with the COD, the Contractor shall perform unforeseen work whenever it is deemed necessary or desirable in order to complete fully the work contemplated. Such work shall be performed as directed or agreed upon and will be paid for a specified time and material rates, approved rental rates, or a lump sum stipulated in the order authorizing the work.

7. BASIS OF AWARD:

Right of Rejection: COD reserves the right to reject any and all Bids, to waive any and all informalities and to negotiate contract terms with the successful bidder, and the right to disregard all non-conforming, non-responsive or conditional bids.

Qualifications and Experience: In evaluating Bids, COD may consider the qualifications, responsibilities, and experience of the Bidders.

Additional Information: COD may conduct such investigation as it deems necessary to assist in the evaluation of any Bid and to establish the responsibility, qualifications, and financial ability of Bidders, proposed sub-Contractors, employees, and other persons and organizations to do the work in accordance with the Contract Documents to COD's satisfaction within the prescribed time.

Partial Award: COD reserves the right to award a partial award of only a portion of the project contained within the solicitation, or to award separate portions of the project to separate bidders. Unless otherwise specified by COD or the bidder, COD may accept any item or groups of items in the Bid as may be in the best interest of COD. If the contract is to be awarded, it will be awarded to the bidder whose evaluation by COD indicates to COD that the award will be in the best interest of COD.

8. TERMINATION:

The contract may be terminated by either party without cause with a thirty (30) day written notice, delivered by certified mail.

9. WARRANTY PERIOD:

If COD determines Contractor's work is defective after the approved final payment and prior to the expiration of one year after the date of Final Completion or such longer period as may be prescribed by law or by the terms of any applicable special guarantee, the Contractor shall promptly, without cost to COD and in accordance with COD's written instructions, either correct such defective work or, if it has been rejected by COD, remove it from the site and replace it with non-defective work. If the Contractor does not promptly comply with the terms of such instruction, COD may have the defective work corrected or the rejected work removed and replaced, and all costs incurred therefore, including compensation for additional professional services, shall be paid by the Contractor and its sureties. The remedies provided in this section are in addition to all other remedies available to COD under applicable laws and shall not be construed as exclusive of any other legal right or remedy available to the COD.

10. INDEMNIFICATION:

The Contractor shall indemnify, defend, and hold harmless COD, the and its officers, agents, employees, board members, successors, volunteers and assignees from any and all claims, lawsuits, losses, and liability arising out of Contractor's failure to perform any of Contractor's duties and obligations hereunder or in connection with the negligent performance of Contractor's duties or obligations, including but not limited to any claims, lawsuits, losses, or liability arising out of Contractor's malpractice.

11. PROJECT SUPERVISION:

COD will provide oversight and coordination of the trail building project. COD will regularly inspect to ensure completed work meets all requirements set forth.

Bid From

In compliance with the Call for Bids, General Provisions, Specifications, Maps and Drawings, the undersigned hereby proposes to furnish all labor and equipment to mobilized and perform all work necessary for the **Broadway Elevator Modernization/ Cab-Entrance Replacement – 2024** for considerations in the following amount \$_____. This figure shall be known as the Bid. The Bid shall include sales tax and all other applicable taxes and fees.

1. That for and in consideration of the amounts specified below, this Contractor shall perform the work of constructing Broadway Elevator Modernization/ Cab-Entrance Replacement – 2024, as further outlined in this bid document, in a good skillful and substantial manner and to the full satisfaction of and under the supervision of the Representative in charge of the Project. In the prosecution of the work, the Contractor shall, at his own cost and expense, furnish all labor, machinery, tools, equipment, materials, and supplies except such equipment and materials which shall be furnished by COD, as provided in the General Provisions, General Specifications, or Individual Specifications, and shall perform the work in strict conformity with the General Provisions, General Specifications, or Individual Specifications relative to this work.
2. In consideration of the covenants and agreements to be kept and performed by the Contractor and for the faithful performance of this Bid and the completion of the work embraced herein according to the plans, specifications, drawings and conditions herein contained and referred to, COD shall pay and the Contractor shall receive and accept as full compensation for everything furnished and done by the Contractor under this proposal and also for all loss or damage arising out of the nature of the work, the action of the elements or from any unforeseen contingencies or difficulties encountered in the prosecution of the work.
3. The contract will be from receipt of the notice to proceed to September 30th, 2024 with an option to extend, by agreement of both parties in writing and subject to the required approvals. There is no right or expectation of extension and any extension will be determined solely at the discretion of the COD. The elevator shall be operational during the following special event dates: June 13-15, 2024, July 4, 2024, July 21-27, 2024, August 2-11, 2024, August 22-24, 2024.
4. Said work shall be commenced upon notice to proceed and shall be completed per contract documents; however, should the Contractor be delayed in the prosecution of the work by any act, neglect or fault of COD, or by any damage caused by fire, flood or other casualty over which the Contractor has no control, then the time herein set for the completion of the work may be extended as determined by mutual agreement of the parties hereto. COD hereby reserves the right to accept and make use of any portion of

said facilities before completion of the entire work without invalidating the contract, binding COD and accept the remainder of the work or any portion thereof, whether completed or not. COD also reserves the right to eliminate or delay parts of the project depending upon Bid and funds available.

5. It is also agreed by the parties hereto that the Call for Bids, Drawing, General Provisions and Specifications, herein referred to, form an essential part of this agreement and whether the same are attached hereto or on file in the office of COD they shall have the same force and effect as if spread at length herein.
6. If written Notice of Acceptance of this Bid is delivered to this bidder within Thirty (30) calendar days after date of bid opening, this bidder will within Twenty (20) calendar days after date of such notice, execute and deliver the Contractor's Certificate(s) of Insurance in accordance with the General Provisions and Bid as accepted.
7. The bidder hereby agrees that should they be awarded this contract, Contractor shall not discriminate against any person who performs work there under because of age, race, religion, color, sex, national origin or ancestry.
8. The bidder also covenants and agrees and that this Bid is made without collusion with any other person, firm or corporation; that they have carefully examined the Call for Bids, General Provisions, Drawings and Specifications, and any and all Addenda governing the work included in this Bid, and fully understands the physical conditions under which the work must be performed.
9. The bidder will perform all extra work that may be required and on the conditions set forth in the General Provisions.

Bid Form (cont.)

1. BY SUBMISSION OF A BID, THE BIDDER CERTIFIES:

- 1.1 Prices in this Bid have been arrived at independently, without consultation, communication or agreement for the purpose of restricting competition.
- 1.2 No attempt has been made nor will be by the bidder to induce any other person or firm to submit a Bid for the purpose of restricting competition.
- 1.3 The person signing this Bid certifies that they are authorized to represent the company and is legally responsible for the decision as to the price and supporting documentation provided as a result of this advertisement.
- 1.4 Bidder will comply with all applicable Federal regulations, policies, guidelines and requirements.

2. GENERAL INFORMATION:

Company Name _____ Phone _____

Signatory's Name _____ Fax _____

Signature & Title _____
(Date)

Mailing Address _____

City _____ State _____ Zip _____

Email Address _____

SSN/Employer Identification Number _____

3. OWNERSHIP AND CONTROL:

Bidder's Legal Structure:

- Sole Proprietorship
- General Partnership
- Corporation
- Limited Partnership
- Limited Liability
- Other _____

Bid Form (cont.)

If Bidder is a sole proprietorship, list:

Owner Name _____ Phone () _____

Mailing Address _____

City _____ State _____ Zip _____

SSN/Employer Identification Number _____

Beginning date as owner of sole proprietorship _____

Provide the names of all individuals authorized to sign for the bidder:

NAME (printed or typed)

TITLE

_____	_____
_____	_____
_____	_____
_____	_____

Bid Form (cont.)

Contractors must provide:

- 1) A minimum of three (3) references with the Bid form to include name, address, telephone number, date of project, and description of services performed, period of performance, and contracted amount.
- 2) Proposed approach to this project, including machines/materials to be utilized, identification and experience of on-site personnel on similar projects with similar machines/materials.
- 3) Please list at least three (3) similar past projects with brief narratives.
- 4) Please provide one (1) letter of recommendation from previous passenger elevator construction or improvement projects with contact information (phone number and email address).
- 5) Provide a recommended schedule/timetable that discloses your window of availability to meet the expectations of this contract.
- 6) Experience constructing and improving passenger elevators?
_____Yes _____No

VERIFICATION

I certify under penalty of perjury, that I am a responsible official (as identified above) for the business entity described above, that I have personally examined and am familiar with the information submitted in this disclosure and all attachments, and that the information is true, accurate, and complete. I am aware that there are significant penalties for submitting false information, including criminal sanctions which can lead to imposition of a fine and/or imprisonment.

(Name and Title)

(Date)

End Bid Form

General Specifications

The passenger elevator for this Request for Proposal (RFP) is in the Broadway Parking Structure in the City of Deadwood, South Dakota. Work includes completion of an on-site investigation of local conditions, furnish all labor, equipment, supplies and materials in performing all operations necessary for the complete and proper modernization/ Cab-Entrance Replacement associated with the project. This contract is for the mobilization and work.

Section 1: General Requirements

1.1 Project Location - The work is in the northeast corner of the Broadway Parking Structure at 630 Broadway Avenue in the City of Deadwood SD. There are no restrictions on access.

1.2 Description of work - The general components of the work to be performed under these plans and specifications include, but are not limited to, a full replacement and upgrade to the power unit, controller, car, and hall stations (“fixtures”), traveling cable, door operator, hoistway wiring, oil replacement, entrance frames, cab replacement and other miscellaneous upgrades. Monthly invoices may be submitted to COD. COD will monitor the progress of the project regularly. The original equipment manuals are available from the COD.

1.3 Submittals - Submittals shall be interpreted to include drawings, data, manuals, certifications, warranties, samples, charts, weekly timesheets and other items furnished by the Contractor for approvals. Submittals will be given to the COD. The following submittals will be required for this project:

- a. Proposed Construction Schedule and Bid Forms.

1.4 Materials - Materials as used in these specifications shall mean equipment, machinery, product, component, or any other item to be incorporated in the work, “Alt-Adds” included.

The Contractor shall make a diligent effort to procure such materials, but, if materials become unavailable, substitute materials may be used, provided no substitute materials shall be used without prior approval by the COD. Materials furnished by the Contractor shall be of the type and quality described in these specifications. The COD’s determination as to whether substitution will be permitted will be final and conclusive.

1.5 Staging area - There are no staging areas within the project area due to parking limitations. All equipment will need to be off loaded and moved directly onto the work site.

1.6 Clean-up - General clean-up will be conducted by the Contractor over the limits of the entire project to the satisfaction of COD unless otherwise arranged. This includes touch-up work, patching, and clean-up of all materials related to this contract and Contractor. Clean-up will not be paid for separately but will be included in the Bid.

1.7 Guarantee and warranty - A one (1) year guarantee and warranty will be provided by the Contractor on all work of this project. Any portions needing replacement or repair within one (1) YEAR FROM THE DATE OF WRITTEN ACCEPTANCE BY COD, shall be completed by the Contractor at their expense, within a time frame agreed upon by COD. All manufacturer warranties shall be transferred to COD.

Section 2: Construction Guidelines

General - Contractor will complete the Broadway Ramp Elevator Modernization/Cab-Entrance Replacement in a manner that ensures passenger safety, is code compliant, meets accessibility Standards, has reliable performance, and improved aesthetics. All materials and work must be compatible with the existing infrastructure. The original design documents are attached. Full-size renderings are available at Deadwood City Hall for review.

Section 3: Detailed Guidelines for Construction

The Contractor will furnish and install the labor, materials, tools and supervision to perform a full replacement and upgrade to the power unit, controller, car, and hall stations (“fixtures”), traveling cable, door operator, hoistway wiring, oil replacement, entrance frames, cab replacement and aesthetic upgrades. The materials and work must be compatible with the existing infrastructure to be kept. The table below lists the current equipment.

DESCRIPTION	VENDOR NAME	JOB/PART #
CAB	MEI	MHP-2847-C
FIXTURES	ADAMS	3903396
JACK	UNITED ELEVATOR	
CONTROLLER	VERTITRON	J98-0263
DOOR PROTECTION	JANUS	PANA FORTY
POWER UNIT	MEI	MHP-2847 SS-88-PU
MOTOR	CENTURY	40 HP
PUMP	IMO-SUBMERSIBLE	250G
VALVE	EECO	UV-5A6
SILENCER	W/M	2”

PLATFORM/SLING	MEI	MHP-2847-F1 & F2
ISOLATION PACKAGE	MEI	
LIMIT SWITCH PACKAGE	MEI	
SELECTOR PACKAGE	VMI	
RAIL GUIDES	ELPRO	36SRG

Section 4: Completion Requirements

4.1 Payment – The Contractor will provide monthly progress reports along with monthly invoices. Any previously agreed upon expenses for materials will be included in the monthly invoice. Payment shall be made monthly.

4.2 General Comments:

- 4.2.1** COD will work with the Contractor to ensure that any and all site-related permits or permissions have been secured to complete the entire project.
- 4.2.2** Contractors must have experience with passenger elevator modernization/Cab-Entrance Replacement consistent with the existing elevator at the Broadway Parking Structure.
- 4.2.3** Workmanship shall be of the best quality. The professional appearance of finished work shall be of equal importance with its intended use. All portions of the work shall be so laid out and installed so that the work, as a whole, is of uniform quality and appearance.
- 4.2.4** Contractor shall prepare a construction schedule showing major construction activities before any construction begins.
- 4.2.5** Contractor acknowledges that they have satisfied themselves as to the nature and location of the work and the general and local conditions of the site by visiting the site or otherwise becoming thoroughly familiar with the site.
- 4.2.6** A pre-construction conference shall be scheduled by the Contractor as soon as practical after the Service Contract has been received by the Contractor. The meeting shall include COD and appropriate representatives of the Contractor who will be responsible for the management of the project. Major subcontractors shall also attend.
- 4.2.7** The Contractor shall make every effort to verify the availability of

materials for this project by the time of the pre-construction conference. Cost of delays because of non-availability of specified items when such delays could have been avoided by the Contractor, shall not be borne by COD. Burden of proof for substituted materials rests with the Contractor. Sufficient documentation must be provided in ample time for review by COD. Contractor must not assume that substitutions will be granted.

- 4.2.8** It shall be the responsibility of the Contractor to become familiar with local or regional code enforcement if any applies to this project.
- 4.2.9** Before performing any work or ordering any materials, the Contractor shall verify all dimensions of any existing and new work and shall be responsible for their accuracy.
- 4.2.10** Contract Time. Said work may commence upon receipt of the Notice to Proceed. Concept of the work is to start and to progress without interruption until the job is complete.
- 4.2.11** The Contractor is responsible for securing equipment from theft and vandalism within the staging area and throughout the build areas. COD will not be held responsible for repair or replacement of item lost or stolen.

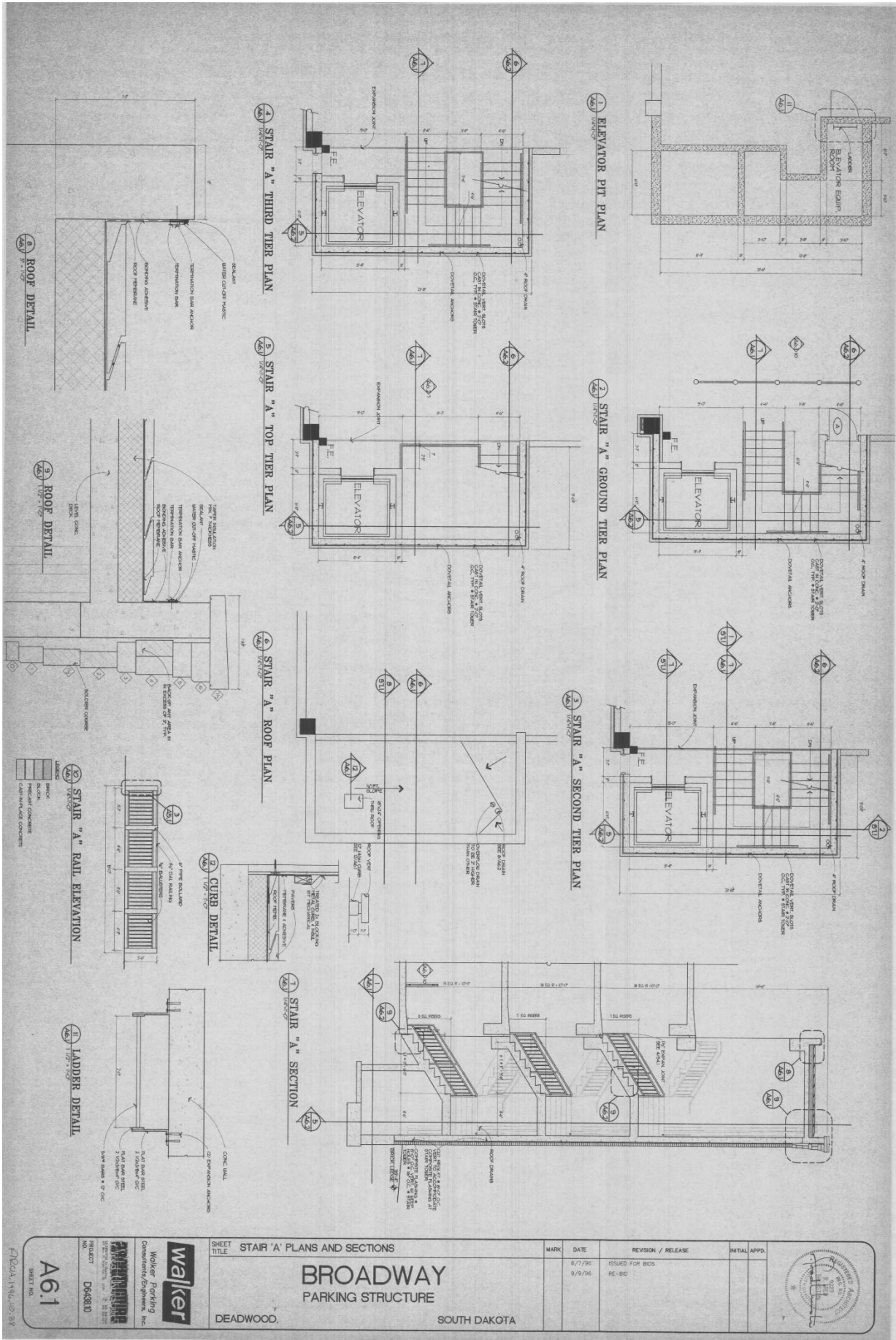

A61 SHEET NO.	Walker Parking Consultants/Engineers, Inc. PROJECT: D562810	SHEET TITLE: STAIR 'A' PLANS AND SECTIONS		MARK: 8/7/96 9/9/96	REVISION / RELEASE: ISSUED FOR BIDS RE-BID	INITIAL APPD.	
		BROADWAY PARKING STRUCTURE DEADWOOD, SOUTH DAKOTA					

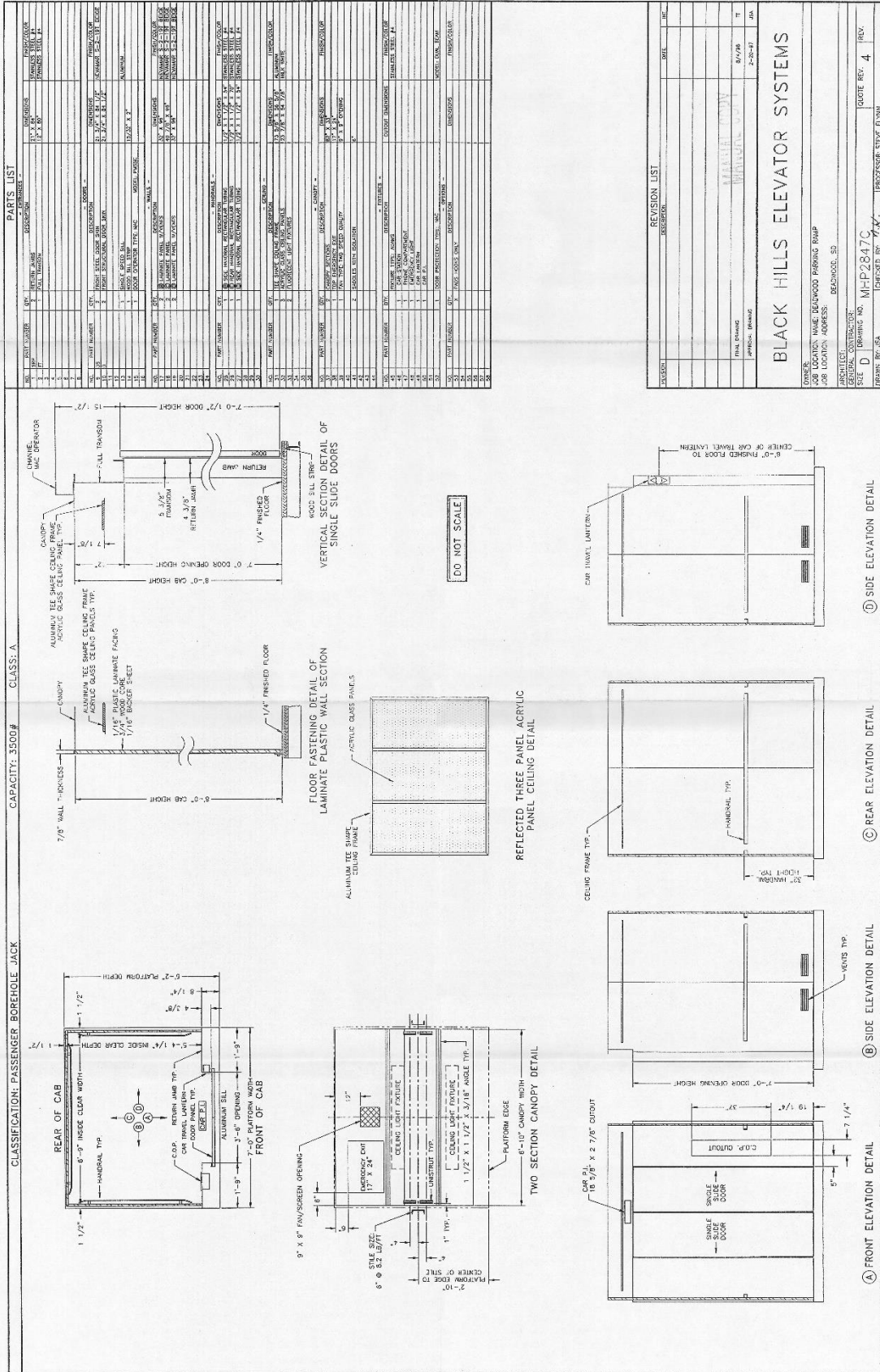

PARTS LIST

NO.	QTY	DESCRIPTION	MANUFACTURER	FINISH
1	1	ALUMINUM TEE SHAPED CEILING FRAME	ALUMINUM	ANODIZED
2	1	ACRYLIC GLASS CEILING PANELS	ACRYLIC	CLEAR
3	1	ALUMINUM TEE SHAPED LAMINATE FASING	ALUMINUM	ANODIZED
4	1	1/4" FINISHED FLOOR	FLOORING	WOOD
5	1	ALUMINUM TEE SHAPED CEILING FRAME	ALUMINUM	ANODIZED
6	1	ACRYLIC GLASS CEILING PANELS	ACRYLIC	CLEAR
7	1	ALUMINUM TEE SHAPED LAMINATE FASING	ALUMINUM	ANODIZED
8	1	1/4" FINISHED FLOOR	FLOORING	WOOD
9	1	ALUMINUM TEE SHAPED CEILING FRAME	ALUMINUM	ANODIZED
10	1	ACRYLIC GLASS CEILING PANELS	ACRYLIC	CLEAR
11	1	ALUMINUM TEE SHAPED LAMINATE FASING	ALUMINUM	ANODIZED
12	1	1/4" FINISHED FLOOR	FLOORING	WOOD
13	1	ALUMINUM TEE SHAPED CEILING FRAME	ALUMINUM	ANODIZED
14	1	ACRYLIC GLASS CEILING PANELS	ACRYLIC	CLEAR
15	1	ALUMINUM TEE SHAPED LAMINATE FASING	ALUMINUM	ANODIZED
16	1	1/4" FINISHED FLOOR	FLOORING	WOOD
17	1	ALUMINUM TEE SHAPED CEILING FRAME	ALUMINUM	ANODIZED
18	1	ACRYLIC GLASS CEILING PANELS	ACRYLIC	CLEAR
19	1	ALUMINUM TEE SHAPED LAMINATE FASING	ALUMINUM	ANODIZED
20	1	1/4" FINISHED FLOOR	FLOORING	WOOD
21	1	ALUMINUM TEE SHAPED CEILING FRAME	ALUMINUM	ANODIZED
22	1	ACRYLIC GLASS CEILING PANELS	ACRYLIC	CLEAR
23	1	ALUMINUM TEE SHAPED LAMINATE FASING	ALUMINUM	ANODIZED
24	1	1/4" FINISHED FLOOR	FLOORING	WOOD
25	1	ALUMINUM TEE SHAPED CEILING FRAME	ALUMINUM	ANODIZED
26	1	ACRYLIC GLASS CEILING PANELS	ACRYLIC	CLEAR
27	1	ALUMINUM TEE SHAPED LAMINATE FASING	ALUMINUM	ANODIZED
28	1	1/4" FINISHED FLOOR	FLOORING	WOOD
29	1	ALUMINUM TEE SHAPED CEILING FRAME	ALUMINUM	ANODIZED
30	1	ACRYLIC GLASS CEILING PANELS	ACRYLIC	CLEAR
31	1	ALUMINUM TEE SHAPED LAMINATE FASING	ALUMINUM	ANODIZED
32	1	1/4" FINISHED FLOOR	FLOORING	WOOD
33	1	ALUMINUM TEE SHAPED CEILING FRAME	ALUMINUM	ANODIZED
34	1	ACRYLIC GLASS CEILING PANELS	ACRYLIC	CLEAR
35	1	ALUMINUM TEE SHAPED LAMINATE FASING	ALUMINUM	ANODIZED
36	1	1/4" FINISHED FLOOR	FLOORING	WOOD
37	1	ALUMINUM TEE SHAPED CEILING FRAME	ALUMINUM	ANODIZED
38	1	ACRYLIC GLASS CEILING PANELS	ACRYLIC	CLEAR
39	1	ALUMINUM TEE SHAPED LAMINATE FASING	ALUMINUM	ANODIZED
40	1	1/4" FINISHED FLOOR	FLOORING	WOOD
41	1	ALUMINUM TEE SHAPED CEILING FRAME	ALUMINUM	ANODIZED
42	1	ACRYLIC GLASS CEILING PANELS	ACRYLIC	CLEAR
43	1	ALUMINUM TEE SHAPED LAMINATE FASING	ALUMINUM	ANODIZED
44	1	1/4" FINISHED FLOOR	FLOORING	WOOD
45	1	ALUMINUM TEE SHAPED CEILING FRAME	ALUMINUM	ANODIZED
46	1	ACRYLIC GLASS CEILING PANELS	ACRYLIC	CLEAR
47	1	ALUMINUM TEE SHAPED LAMINATE FASING	ALUMINUM	ANODIZED
48	1	1/4" FINISHED FLOOR	FLOORING	WOOD
49	1	ALUMINUM TEE SHAPED CEILING FRAME	ALUMINUM	ANODIZED
50	1	ACRYLIC GLASS CEILING PANELS	ACRYLIC	CLEAR
51	1	ALUMINUM TEE SHAPED LAMINATE FASING	ALUMINUM	ANODIZED
52	1	1/4" FINISHED FLOOR	FLOORING	WOOD
53	1	ALUMINUM TEE SHAPED CEILING FRAME	ALUMINUM	ANODIZED
54	1	ACRYLIC GLASS CEILING PANELS	ACRYLIC	CLEAR
55	1	ALUMINUM TEE SHAPED LAMINATE FASING	ALUMINUM	ANODIZED
56	1	1/4" FINISHED FLOOR	FLOORING	WOOD
57	1	ALUMINUM TEE SHAPED CEILING FRAME	ALUMINUM	ANODIZED
58	1	ACRYLIC GLASS CEILING PANELS	ACRYLIC	CLEAR
59	1	ALUMINUM TEE SHAPED LAMINATE FASING	ALUMINUM	ANODIZED
60	1	1/4" FINISHED FLOOR	FLOORING	WOOD

REVISION LIST

NO.	DATE	DESCRIPTION
1		ISSUED FOR PERMIT
2		REVISED PER COMMENTS
3		REVISED PER COMMENTS
4		REVISED PER COMMENTS

BLACK HILLS ELEVATOR SYSTEMS

JOB LOCATION: WALK BEACON PARKING RAMP
 JOB LOCATION ADDRESS: BEACON, SD
 ARCHITECT: BEACON, SD
 GENERAL CONTRACTOR: MHP-2847C
 SIZE: D
 DRAWING NO.: MHP-2847C
 DRAWN BY: JAK
 CHECKED BY: JAK
 QUOTE REV. 4
 DATE: 2-28-21

MATERIAL LISTED BELOW IS FOR (1) PLATFORM ASSEMBLY

ITEM	MATERIAL	DESCRIPTION	QTY.
A	4" x 2" x 11GA x 7'-0"	PLATFORM FRONT TUBE	1
B	4" x 2" x 11GA x 7'-0"	PLATFORM REAR TUBE	1
C	2" x 3" x 1/4" x 5'-9 15/16"	STRINGERS	6
E	1 5/8" x 1 5/8" x 22"	PLATFORM UNISTRUT	2
F	15/32" PLYWOOD	SUBFLOOR	X
G	15/32" PLYWOOD	SUBFLOOR	X
H	5'-0" TOE GUARD	TOE GUARD	1
J	TOE GUARD SUPPORT (STOCK ITEM)	TOE GUARD SUPPORT	1
K			2

REAR PLATFORM WITH NO OPENING

PLATFORM UNISTRUT

PLATFORM FRONT CENTER OPENING

FRONT DECK SILL

FLOORING DETAIL

FINISH REQUIREMENTS

Finish Color: A=EN
 CHECK IF CORRECT: PLATFORM SIZE
 * Per print specifications checked against manufactured components

FABRICATED BY: _____ DATE: _____
 CHECKED AND MARKED BY: _____ DATE: _____

PLATFORM FASTENER PACKAGE FOR (1) PLATFORM ASSEMBLY

PART	QTY.	DESCRIPTION	ITEM
TOXK 1/4" x 20 x 1 1/2"	20	TOE GUARD TO SUBFLOOR TO STRINGERS	G-C
TKK 1/4" x 14 x 3/4"	4	TOE GUARD TO TUBE	H-D
HHCS 5/8" x 11 x 2"	4	UNISTRUT TO BOLSTER	E
HHCS 5/8" x 11 x 2"	4	UNISTRUT TO PLATFORM	I-C

(1) PLATFORM ASSEMBLY REQ'D.

BLACK HILLS ELEVATOR COMPANY

DRAWN BY: M.B. DATE: 8/6/98
 APPROV. BY: J.C. DATE: 1/1/32
 TOLERANCES: PART NAME: PLATFORM ASSEMBLY
 ± 1/32
 JOB NAME: DEADWOOD PARKING RAMP
 PART NO. MHP2847-F2
 SCALE: NONE
 REV. A

MATERIAL LISTED BELOW IS FOR (1) PIT ASSEMBLY

ITEM	PART NUMBER	PART DESCRIPTION	PART NAME	QTY.
A	120-4054	TUBE 4 x 2 x 11 GA. x 2'-8"	BUFFER STAND LENGTH	2
B	11X-XXXX	ANGLE -1'-2 15/16"	PIT CHANNEL SPACER	2
C	120-XXXX	CHANNEL 6" [@8.2# X 3'-6"	PIT CHANNELS	2
D	120-5067	CHANNEL 6" [@8.2# X 6"	BUFFER SEAT	2
E	711-0150	PIPE - BLK 1 1/2" SCHEDULE 40 X 7 5/16"	SPRING STOP PIPE	2
F	183-0005	SPRING - INNER D-5	BUFFER SPRING	2
G	183-0007	SPRING - OUTER D-5	BUFFER SPRING	2
H	099-1920	LABEL - BUFFER TAG	BUFFER TAG	2

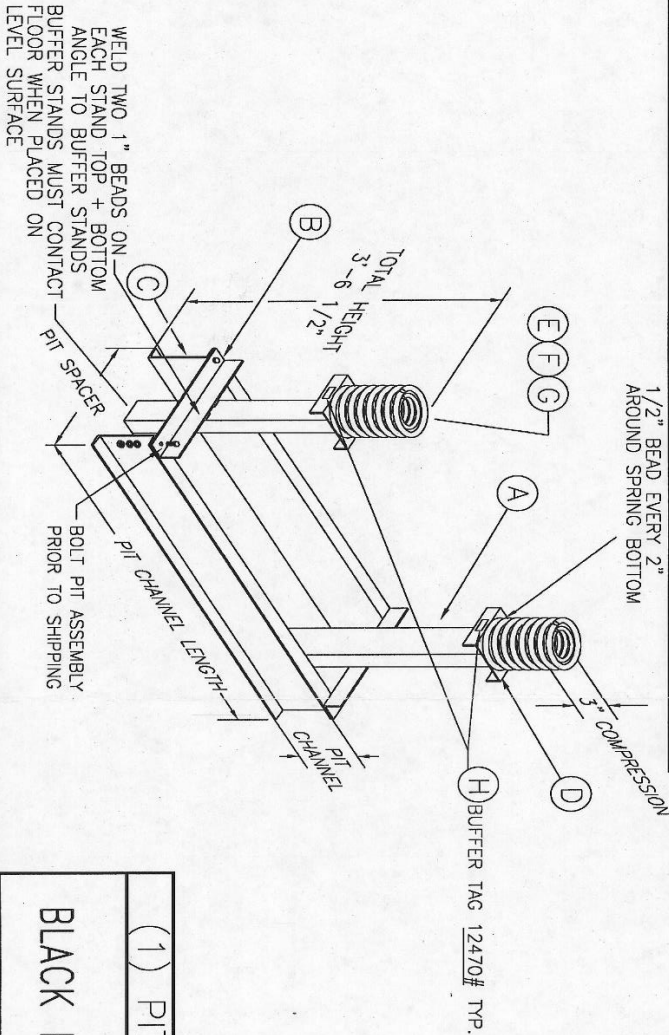

PIT ASSEMBLY FASTENER PACKAGE FOR (1) PIT ASSEMBLY

PLT SHIP BOLTS	NUTS	HEX NUTS	COBREST/PLT NUTS	LOCK WASHERS	PLT WASHERS	BEVEL	1/2" S.I.D. CLIPS	5/8" S.I.D. CLIPS	STEEL ANCHORS	DESCRIPTION	ITEM
XXX-XXXX QTY = 4	HCS 5/8-11 x 2"	XXX-XXXX QTY = 4	XXX-XXXX QTY = 4	XXX-XXXX QTY = 4	XXX-XXXX QTY = 4	XXX-XXXX QTY = 4	XXX-XXXX QTY = 4	XXX-XXXX QTY = 4	XXX-XXXX QTY = 4	PIT CH. SP. / PIT CHANNEL / PIT ASSEMBLY / JACK	B-C

(1) PIT ASSEMBLY REQUIRED

BLACK HILLS ELEVATOR COMPANY

FINISH REQUIREMENTS
 Finish Color: ANTI-BLUE NIGHT Primer: _____
 QUALITY CONTROL
 * Per print specifications checked against manufactured components
 CHECK IF CORRECT: _____ PIT ASSEMBLY
 FABRICATED BY: _____ DATE: _____
 CHECKED AND MARKED BY: _____ DATE: _____

DRAWN BY: M.B. DATE: 8/7/98 G:\DRAWINGS\TAB-BLKSPRNGS\SPRINGBRI REV: A
 APPRV BY: *[Signature]* DATE: _____ TOL: ±1/32 MATERIAL: AS NOTED
 TOLERANCES: PART NAME: PIT ASSEMBLY
 SCALE: PART NO. MHP2847-F3 RUN #38
 NONE

A2474-1997.13.5

REV. NO.	ECO NO.	DESCRIPTION OF CHANGE	DATE
A		RELEASED FOR PRODUCTION	

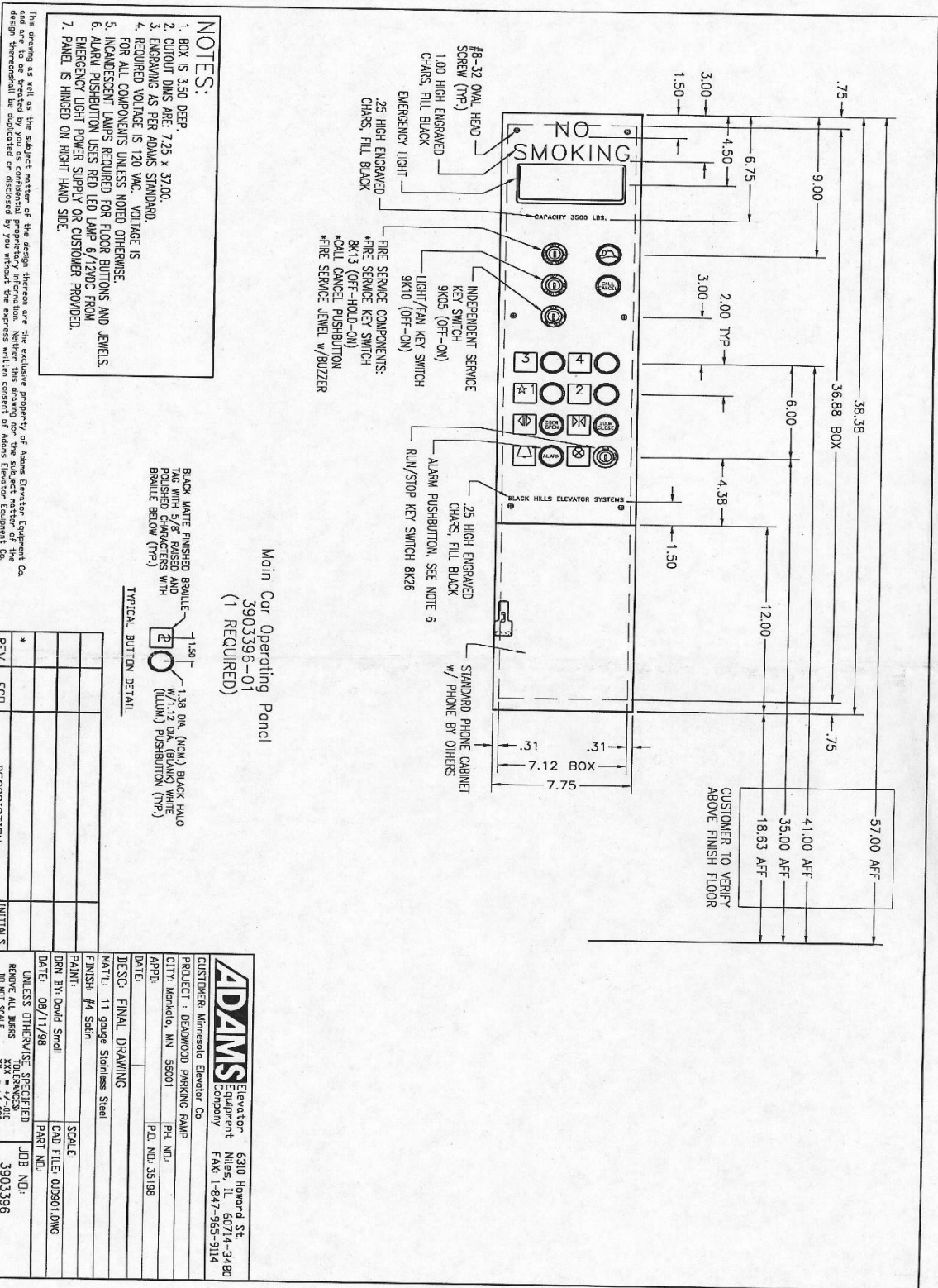

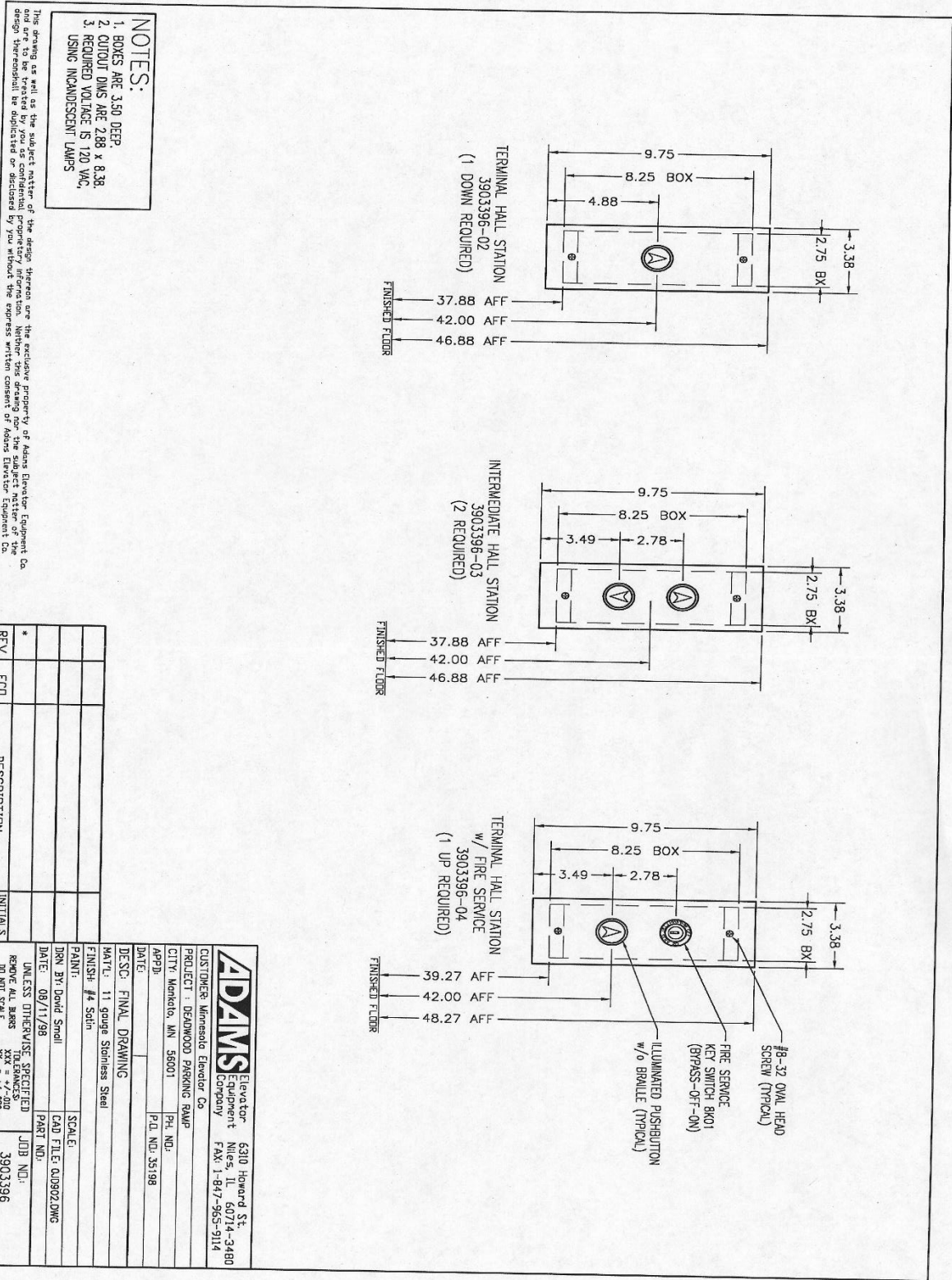

- NOTES:**
1. BOXES ARE 3.50 DEEP
 2. CUTOFF DIMS ARE 2.88 X 8.38
 3. REQUIRED VOLTAGE IS 120 VAC, USING INCANDESCENT LAMPS

This drawing as well as the subject matter of the design, drawings and the exclusive property of Adams Elevator Equipment Co. and are to be treated by you as confidential proprietary information. No part of this drawing shall be duplicated or disclosed by you without the express written consent of Adams Elevator Equipment Co.

REV.	ECD	DESCRIPTION	INITIALS	DATE
*				

ADAMS Elevator Equipment Company
 6310 Howard St. Niles, IL 60714-3480
 FAX: 1-847-965-9114

CUSTOMER: Minnesota Elevator Co.
 PROJECT: DEANWOOD PARKING RAMP
 CITY: Mankato, MN 56001
 APPD: P.H. MDI
 DATE: P.L. NO. 35198

DESC: FINAL DRAWING
 MATE: 11 gauge Stainless Steel
 FINISH: #4 Satin
 DSN: BY David Small
 DATE: 08/11/98
 CAD FILE: 020902.DWG

UNLESS OTHERWISE SPECIFIED REMOVE ALL BARS
 DD NOT SCALE
 XXX = +/- .000
 AND = +/- .005

JOB NO.: 3903396
 SHT. 2 OF 3

H/2CH. 1947. 13. 7

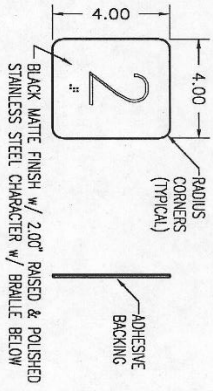
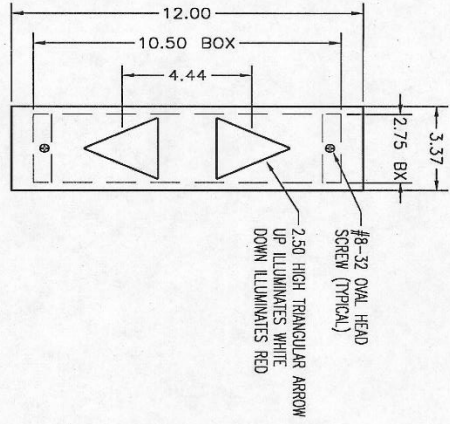
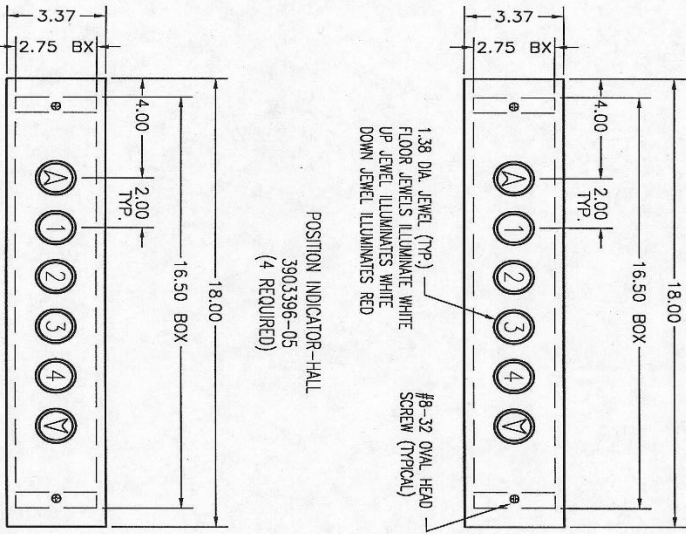

- NOTES:**
1. BOXES ARE 3.50 DEEP.
 2. CUTOUT DIMS FOR -05, -06 ARE 2.88 x 14.63
 3. REQUIRED VOLTAGE IS 120 VAC, USING INCANDESCENT LAMPS

This drawing as well as the subject matter of the design thereon are the exclusive property of Adams Elevator Equipment Co. and are to be treated by you as confidential proprietary information. Neither this drawing nor the subject matter of the design thereon shall be duplicated or disclosed by you without the express written consent of Adams Elevator Equipment Co.

REV.	ECO	DESCRIPTION	INITIALS & DATE
*			

ADAMS Elevator Equipment Company
6310 Howard St.
Mpls, IL 60714-3480
FAX 1-847-963-9114

CUSTOMER: Minnesota Elevator Co
PROJECT: DEANWOOD PARKING RAMP
CITY: Mendota, MN 56001
APPD: P.D. NO. 35198
DATE: 08/11/98

DESC: FINAL DRAWING
MATERIAL: 11 gauge Stainless Steel
FINISH: #4 Satin
PAINT: SCAL E.I.
DRN BY: David Smoll
DATE: 08/11/98
JOB NO.: 3903396
SHT. 3 OF 3

TOLERANCES:
XX = +/- .000
XX = +/- .005
ANG = +/- .1 DEG

REMOVE ALL BARRS
DO NOT SCALE
DRAWING

ARCH. 1997. 13. 03

