

ONE CALL
BEFORE DIGGING
1-800-781-7474

SOUTH DAKOTA



DEADWOOD RAILROAD AVENUE WATER MAIN EXTENSION DEADWOOD, SOUTH DAKOTA TDG PROJECT NO. 24-010

RAPID CITY, SOUTH DAKOTA



PROJECT LOCATION MAP
NOT TO SCALE

INDEX OF SHEETS

- 1 TITLE
- 2-7 GENERAL NOTES / LEGEND / SECTIONS
- 8 QUANTITIES
- 9 EXISTING CONDITIONS
- 10 EROSION CONTROL NOTES
- 11 OVERVIEW
- 12-14 SURVEY CONTROL
- 15-26 WATER MAIN PLAN AND PROFILE
- 27 GRADING PLAN
- 28 INTERSECTION PLAN
- 29 DETAILS

Project Name:
DEADWOOD RAILROAD AVENUE
WATER MAIN EXTENSION

Legal Description:

Description:
CONSTRUCTION OF
APPROXIMATELY 1 MILE OF
12" WATERMAIN

Right-of-Way
Other Streets = 66'

PLANS FOR



TDG

Towey Design Group
147 Chisholm Drive
Box Elder, SD 57719
605.600.3758

CITY APPROVAL

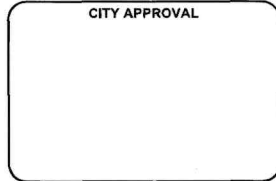

SD DANR APPROVAL



CONSTRUCTION SERVICES



SHEET NAME:
TITLE



SHEET NO:
1

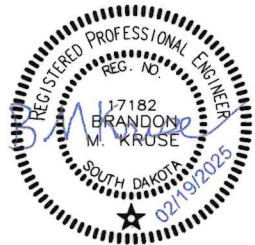
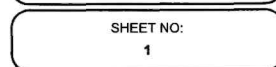

I, BRANDON KRUSE CERTIFY THAT THESE PLANS AND SPECIFICATIONS WERE PREPARED UNDER MY DIRECT SUPERVISION AND THAT I AM A DULY REGISTERED PROFESSIONAL ENGINEER UNDER THE LAWS OF THE STATE OF SOUTH DAKOTA.

Brandon M. Kruse

ENGINEER:

02/19/2025

DATE:

P:\24-210 - 2024 - Bid - Bidder - Job - Estimate\24-210-201 - Engineering\Drawings\Sheet\UTM200 - SWPPP.dwg 2/17/2025 8:17am
 COLOR PLANS - GREY TONING

Specifications To Be Used

All work shall be constructed in accordance with the City of Rapid City Standard Specifications for Public Works Construction, 2022 Edition (Standard Specifications) with all current updates, except as modified in the bid documents.

The Contractor shall notify the Engineer of conflicts between drawings, Project Manual, and the Standard Specifications.

Geotechnical Investigation

A geotechnical investigation entitled "Report of Geotechnical Exploration - Deadwood Water Main Project, Deadwood, South Dakota" was completed on August 26, 2024 by AET. The geotechnical report is provided for the bidder's information. The Contractor shall use this information as necessary to complete bidding proposals.

It is the Contractor's responsibility to review the geotechnical report prior to bidding this project. The Contractor may use this report at his or her own risk.

Excavation, placement of fill, and utility requirements shall be in accordance with the Standard Specifications and per the geotechnical evaluation.

Project Note

This plan set includes information for the approximately 1 mile long 12" watermain to connect the Zone 2 water main from the corner of Sherman street and highway 14A along Railroad Avenue finishing near the Deadwood City shop located near the Days of 76 complex. The connection point near the Deadwood City shop is connecting to a 284 psi water main. Contractor to coordinate with the City of Deadwood for this connection point. The sanitary sewer shown on the plans may be the 36" Lead-Deadwood sanitary trunk main, the watermain is designed to keep clear of this main with minimal crossings. The uphill and downhill slopes along Railroad Ave are known to sluff and slide, the watermain is designed to stay away from these sloped areas to avoid erosion issues. Contractor to take care of disturbance of the slopes by providing adequate erosion control and by reducing cuts into the slopes whenever possible.

Progress Meetings

Progress meetings will be held at least bi-weekly, and more frequently in critical areas. The bi-weekly meeting schedule will be established at the preconstruction meeting.

Progress meetings will be held at an offsite location arranged by the Contractor.

Erosion and Sediment Control

The Contractor is responsible to implement and maintain the erosion and sediment control plan, located within the project drawings, and in accordance with the City of Rapid City Stormwater Quality Manual, the Standard Specifications and other SDDANR rules and regulations.

The Contractor is advised that several agencies have the authority to "Stop Work" if the pollution prevention control is not implemented or is not effective. No compensation will be forthcoming for "Time Lost" due to a "Stop Work Order".

Project Coordination

The Contractor is responsible for coordinating work with all adjacent property owners that will be temporarily impacted by construction of this project.

Project Record Drawings

The Contractor shall measure and record any horizontal or vertical deviations from the contract drawings. The changes shall be recorded in an accurate, neat fashion on the drawings and furnished to the Engineer upon completion of the project. Specifically, all service taps, connections, anodes, and buried fittings shall be recorded for the work. The as-built drawings shall be onsite and available for review by the Engineer upon request.

Preconstruction Meeting

A preconstruction meeting will be scheduled and will require attendance by the Contractor and all subcontractors working on the project. The preconstruction meeting will not be scheduled until all required submittals have been received and approved.

Stockpiled Materials

Requests for payment for stockpiled materials shall be accompanied by invoices with the respective bid item number indicated for each individual stockpiled material. The Contractor shall be fully responsible for preparing and submitting documentation in the form and format required by the Engineer to be considered for payment. Stockpiled materials considered for payment shall be stored within the project limits as identified on the plans, or at a secure location accessible to the Owner's representative.

Submittals

Submittals are required for all items listed below and as required in the detailed specifications. A submittal schedule is provided in Section 01330 of the Detailed Specifications. This submittal schedule will be utilized throughout construction by the Contractor and Engineer for tracking of submittals.

The Contractor shall submit the following items to the Engineer a minimum of ten (10) working days prior to the preconstruction meeting:

- Detailed construction schedule;
- Traffic control plan for the entire project;
- A copy of the notice of intent to the SDDANR (prepared by the Contractor and submitted to the Owner);
- A copy of the Contractor's SDDANR temporary discharge permit;
- A copy of the Contractor's Stormwater Pollution Prevention Plan;
- List of licensed pipe installers who will be on the project;
- Certificate of Insurance for railroad permit.

The Engineer will not schedule the preconstruction meeting until all the items listed above have been submitted and approved.

Utilities

The information on these drawings concerning the type, size, and location of utilities has been shown based upon the best information available at the time of the design survey. The Contractor is responsible for determining the exact location of all utilities prior to beginning construction. The Contractor is responsible for protecting all existing utilities in place.

The Contractor shall coordinate all relocations with the utility companies. Electric, telephone, television, fiber and gas utilities may be adjusted and/or relocated by the respective utility companies.

Construction Schedule

The Contractor shall prepare and submit a detailed construction schedule a minimum of ten (10) working days prior to the preconstruction meeting. The construction schedule shall be approved by the Engineer prior to issuing the notice-to-proceed.

The construction schedule shall be prepared using industry standard project management software. The schedule shall show the work in a horizontal bar chart or other graphic format indicating times (in days or by dates) for starting and completing various stages of work. The construction schedule shall include sufficient detail to track all major work items, specialty work, delivery of materials, traffic control, phasing and sequencing of work, final surface restoration, significant milestones, etc. The schedule shall be submitted in paper or electronic form.

The Contractor shall update the construction schedule at the request of the Engineer, if, in the Engineer's opinion, it no longer represents the actual prosecution and progress of work. The Contractor shall also submit an updated construction schedule in the event the Contractor's planning for the work is revised.

Traffic Control

The Contractor is required to maintain traffic control during construction in accordance with the Manual of Uniform Traffic Control Devices (MUTCD) and the Standard Specifications. All traffic control shall conform to the latest edition of both documents.

No conceptual traffic control plan has been developed. It is the responsibility of the Contractor to develop a Traffic Control Plan (TCP) compliant with all necessary criteria. Periodic TCP updates may be required as the project progresses. The TCP shall insure vehicular and pedestrian safety during the construction of the project.

The Contractor shall prepare and submit (not less than seven (7) working days prior to the preconstruction meeting) a TCP including pedestrian and bicycle traffic to the Engineer for the proposed construction. The TCP shall be prepared by persons regularly involved in preparation of TCP's, shall conform to the latest revision of the MUTCD, and shall be drawn to scale with dimensions shown for placement of all traffic control devices. TCP's shall be submitted for each phase or project sequence and TCP shall demonstrate changes in the TCP from one phase to the next.

Certified flaggers, properly attired and preceded by W20-7A flagger symbol signs may be required to safely maintain traffic when work activities and/or equipment presents a hazard to workers or traffic, encroaches into a lane open to traffic, or may be required to safely maintain traffic when working near an intersection.

The Contractor is required to have a person available 24 hours a day, 7 days a week to maintain traffic control devices. The name and telephone number of this person shall be given to the Engineer at the Pre-Construction Meeting.

License

The related work includes the installation of water mains, sanitary sewer mains, and associated work. Contractor must hold current water and sewer installer's license with the City of Deadwood to perform the work. The licensee shall perform the work. A copy of the license shall be submitted to the Engineer prior to work commencement.

Permits

The Contractor shall be responsible for obtaining all necessary permits for this project including, but not limited to, the following:

PERMIT:	NOT REQUIRED BY CITY	BY CONTRACTOR	NOTES
Contractor Authorization Form, SDDANR SWPPP		X	NOI by City
SDDANR Permit for Temporary Discharge		X	If needed
SDDANR Water Approval		X	

Protection Of Existing Features

Existing features, including trees, landscaping, pavements, structures, etc., not called out for removals; or remove and reset; shall be protected by the Contractor. Methods of protection shall be submitted to and approved by the Engineer prior to construction.

Irrigation Systems

The Contractor is responsible to cut and cap existing irrigation systems at the project limits. The Contractor shall salvage all sprinkler heads and system components and shall be responsible for the protection and replacement of all components. If any component is damaged during the course of construction, it shall be replaced at the Contractor's expense.

Contractor is responsible for documenting functionality of any irrigation system prior to removal. The City shall require the system to be repaired to the same or better functionality after the project. The Contractor shall coordinate removal and repair directly with the property owner and shall provide the City with documentation.

Construction Limits

In general, the construction limits for the project shall be defined as property lines, right-of-way lines, existing utility easement and temporary construction easement lines unless indicated otherwise on the drawings or further defined herein.

Construction activities shall be restricted to the construction limits unless prior approval is received from the Engineer.

Staging Areas

A recommended staging area has not been identified in these plans. If the Contractor wishes to stage materials in locations outside the work limits, the Contractor is responsible for obtaining written permission from the owner of the proposed location and the Engineer. Copies of any written permission shall be delivered to the Engineer. The Contractor shall be responsible for any necessary permits for the staging area. The City of Deadwood may provide additional staging areas near the south and north ends of the project, contractor to verify availability with the City of Deadwood.

Temporary Construction Easements

Temporary construction easements have been obtained along the project limits. Disturbance of private property within these easements other than that specifically directed within these plans or authorized by subsequent construction change orders approved by the Engineer is prohibited. The Contractor is responsible for repairs to any disturbance or damage within the easements not authorized by the Engineer.

The Contractor shall limit disturbance to only what is required to build the proposed project. Quantities for surface restoration items are limited to what has been identified in the plans unless increases are approved by the Engineer. The Contractor shall restore all areas disturbed by his operations at no additional cost to the Owner.

TDG
 Towy Design Group, Inc.
 147 Chisholm Drive
 Box Elder, SD 57719
 605.600.3758

LOGO:



**DEADWOOD RAILROAD AVENUE
 WATER MAIN EXTENSION
 DEADWOOD, SOUTH DAKOTA**

REVISIONS:
 35% DESIGN PLANS
 95% DESIGN PLANS

JOB NUMBER: 24-010
 DESIGNED BY: BK
 DRAWN BY: BK/NR
 SURVEYED BY:
 SURVEY DATE:

SHEET NAME:
GENERAL NOTES
 SHEET NO:
 2

24-010 - RD Railroad Water Main Extension 11-2016-2017 Estimated 10-month construction period. WBS# 24-010-001 2/17/2024 11:17am

Contractor Furnished Staking

All staking on the project will be by the Contractor in accordance with the Standard Specifications. Payment for Contractor-furnished staking will be at the contract lump sum price for "Construction Staking".

Incidental work

This work includes all miscellaneous items not included under the regular items covered by unit prices as listed in the proposal, but which must be performed in order to complete the contract. Incidental work includes, but is not limited to the following:

- Dust control;
- Coordinate with/adjust private utilities;
- Protection of existing features/utilities;
- Coordinate with RCPE Railroad;
- Railroad Flagging
- Applicable permits and fees to complete the project;
- Existing utility location and verification;
- Exploratory excavation;
- Project coordination, including landowner, public service announcements, etc.;
- Waste disposal site;
- Dewatering;
- Water for compaction;
- Grading around inlets and outlets;
- Water main abandonment.

Material Stockpile Identification

The Contractor shall clearly identify material stockpiles so that material types and uses are clearly identified, for example - bedding, base course, gravel cushion for sidewalk, topsoil, overburden, foundation, etc.

Dewatering Permits

Dewatering permits shall be conducted in accordance with the Standard Specifications Section 11.3, and in accordance with the following additional requirements.

Dewatering activities shall be conducted in compliance with the "General Permit to Discharge under the Surface Water Discharge System for Temporary Dewatering Activities in South Dakota" SDDENR Permit No. SDG 070000. A copy of this permit is available through SDDENR. The Contractor is required to furnish the "Request for Authorization" to SDDENR required under the Permit and for each schedule, obtain SDDENR Authorization, and furnish a separate copy of authorization to the respective Owner at the Pre-Construction Conference.

The Contractor is responsible for performing self-monitoring activities including sampling, testing and reporting as may be determined to be required under the authorization to discharge. Payment for obtaining the necessary authorization to discharge, and for all compliance activities and obligations by the Contractor shall be absorbed into the item which it relates. No additional payment will be made.

Project acceptance and warranty period

The warranty period for this project shall conform to Section 7.65 of the standard specifications with the exception that the warranty period will not begin until the project is 100% complete and shall be based on completion of different phases.

Material Ticket Submittals and Stockpiles

The Contractor shall clearly identify material stockpiles for various products used on the project, i.e. pipe bedding, temporary surfacing, gravel cushion, base course, cushion for sidewalk, driveways, etc.

The Contractor shall submit all tickets for measurement and payment to the Inspector within 48 hours, per Standard Specifications. Any ticket received later than 48 hours will not be accepted and payment for that item will not be made. All tickets shall accompany the material to the site. No hand written tickets shall be allowed.

Exploratory Excavation

The Contractor shall provide exploratory excavation as necessary for the completion of the work under this contract. No separate payment will be made for exploratory excavation.

Unclassified Excavation

All materials, except rock, encountered during construction for the roads and as shown on the cross sections and grading plans regardless of their nature or manner in which they are removed will be considered unclassified excavation.

The contractor shall haul excess material to an offsite location approved by the Engineer. Hauling excess material off the site shall be incidental to the bid item "Excavation, Unclassified."

Plans quantity will be the basis for payment, provided the project is constructed to the lines and grades specified. Measurements will not be made except those necessary to determine that the work has been performed in conformance with the plans.

Shale in any form shall not be considered rock. No separate payment for rock excavation shall be made.

Unclassified Excavation-Digouts

A quantity of Unclassified Excavation-Digouts has been included in the estimate of quantities for possible unstable areas. Unclassified Excavation-Digouts consists of the removal and disposal of unstable material below a surface which has been properly prepared for surfacing material (asphalt or concrete paving) to be placed upon. Unless otherwise permitted by the Engineer, the in-place gravel base shall be salvaged before and replaced after the unsatisfactory material has been removed. The exposed surface shall be compacted prior to backfilling with material approved by the Engineer. If granular material is used for backfill, the excavated area shall extend to a daylight point or points such that lateral drainage is provided. This work item requires pre-authorization by the Engineer to be eligible for payment. Payment will be based on field measurement of quantities under the bid item "Unclassified Excavation, Digouts"

Crushed Rock

A quantity of Crushed Rock is included in the estimate of quantities for use as backfill at possible unstable areas. Crushed Rock shall meet the following requirements:

- Material shall be crushed rock.
- Material shall have a minimum of two fractured faces.
- Percent passing the 8" sieve 100%
- Percent passing the 6" sieve 95%-100%
- Percent passing the 3" sieve 0%-10%
- Percent passing the 2" sieve 0%- 5%

This work item requires pre-authorization by the Engineer to be eligible for payment.

Excavation and disposal of unstable material where the crushed rock will be placed, regardless of type, shall be incidental to the contract unit price for Crushed Rock.

Drainage fabric shall be placed as directed by the Engineer between the crushed rock and Type 1 bedding material. Payment for the drainage fabric used in this installation shall be considered incidental to the bid item for "Crushed Rock".

Payment will be based on field measurement of quantities under the bid item "Crushed Rock" per ton.

Contractor Provided Water

The Contractor shall be responsible for providing water for compaction of earthen and granular materials used for, but not limited to, grading, subgrade preparation, and trench backfill. Water needed for street cleaning, and other miscellaneous items shall also be provided by the Contractor. The City will make water available for purchase at a fire hydrant near the project. There will be no separate payment for water. The costs for purchasing, loading, transporting, and applying/incorporating water shall be incidental to the various items where water is required.

The Contractor will be required to pay for meter fees and installation onto a fire hydrant if the water is purchased from the City of Deadwood.

Embankment

Compaction of earth embankment shall be in accordance with Section 31.23.16 of Standard Specifications, or as modified by the Report of Geotechnical Exploration.

Compaction of earth embankment shall be governed by the specified density method.

For earthwork quantity calculation purposes, topsoil is considered to be placed after final excavation and embankment grades shown on plans have been achieved. Over excavation or under embankment where necessary to match final topsoil placement with finished concrete or asphalt surfaces will be considered incidental work and no separate measurement or payment will be made.

Contractor furnished water for compaction of embankment shall be incidental to the bid item "Excavation, Unclassified."

Embankment quantities were computed assuming a shrinkage factor of 20%. No separate measurement or payment of embankment quantities will be made.

Undercutting

In cut sections and in shallow fill sections, the entire roadway width as shown in the typical sections shall be undercut one foot below the earthen subgrade surface. The undercut material or other suitable material, as directed by the Engineer, shall be moisture conditioned to within +/-3% of optimum moisture content, replaced and compacted to at least 95% of maximum proctor density.

Plans quantity will be the basis of payment. Payment for undercutting will be at the unit price per cubic yard for "Excavation, Undercut".

Trench Backfill

All water and storm sewer trench backfill shall be in accordance with the project geotechnical report and the notes and details provided in these plans.

Testing

All testing on the project shall be in accordance with the Standard Specifications and Detailed Specifications.

The Contractor is responsible for asphalt, concrete, and any testing required for utilities.

The Contractor is responsible for all backfill, embankment, subgrade, and granular materials testing.

Rock Excavation, (Trench)

A quantity of rock excavation, (trench) has been included in the Bid Quantities. There may be some cases where during the course of trench excavation the Contractor may encounter material that would fall the requirements of Section 11 of the Standard Specifications. In this case, the Contractor shall notify the Engineer to verify conditions.

Rock excavation, (trench) shall comply with Section 11 of the Standard Specifications. Measurement and payment will be as described in Section 11. The Engineer will be responsible for measurement of rock excavation, (trench) quantities.

Foundation Material And Imported Backfill (Trench)

Although no groundwater was encountered at the time of soils exploration, the geotechnical report recognizes groundwater may be encountered along portions of the project. If groundwater is encountered, excavated soils will likely be above optimum moisture content. These conditions do not deem the excavated material unsuitable and is not justification for the use of imported material.

The Contractor shall be responsible for either drying the wet but otherwise suitable material or hauling in drier material at no additional cost to the City. The use of imported backfill will only be authorized by the Engineer, if in the Engineer's opinion, there is insufficient quantity of suitable backfill material, including material that can be dried.

Quantities of Type 1 Bedding Material, and Types 3 and 4 Foundation Materials have been included in the estimate of quantities for use where unstable trench bottom is encountered. These materials shall be a crushed rock having a minimum of two fractured facing meeting the following gradations requirements by dry weight:

Type 1 Bedding Material	
Passing 1-inch sieve	100%
Passing 3/4-inch sieve	90-100%
Passing 3/8-inch sieve	20-55%
Passing #4 sieve	0-10%
Passing #8 sieve	0-8%
Type 3 Foundation Material	
Passing 3-inch sieve	100%
Passing 1-inch sieve	0-15%
Passing #4 sieve	0-8%

Type 4 Foundation Material	
Passing 8-inch sieve	100%
Passing 6-inch sieve	65-85%
Passing 3-inch sieve	0-20%
Passing #200 sieve	0-5%

The use of Type 1 Bedding and Types 3 and 4 Foundation Materials shall be authorized by the Engineer prior to placement. Excavation and disposal of unstable material where foundation material will be placed, regardless of type, shall be incidental to the contract unit price for each respective type



Towey Design Group, Inc.
147 Chisholm Drive
Box Elder, SD 57719
605.600.3758

LOGO:



**DEADWOOD RAILROAD AVENUE
WATER MAIN EXTENSION
DEADWOOD, SOUTH DAKOTA**

REVISIONS:
35% DESIGN PLANS
95% DESIGN PLANS

JOB NUMBER: 24-010
DESIGNED BY: BK
DRAWN BY: BK/NR
SURVEYED BY:
SURVEY DATE:

SHEET NAME:
GENERAL NOTES
SHEET NO: 3

Reestablishing Property Corners

The Contractor shall be responsible for reestablishing property corners that are disturbed during the construction of this project. Property corners that require reestablishment may not be reestablished using the stations and offsets that are shown on the plans. Property corners disturbed during this project shall be reestablished by a Registered Land Surveyor. All corners along the project that were found during the topographic survey are shown on the plans. Any corners that are disturbed shall be reestablished by the Contractor.

Payment will be made to the Contractor for reestablishing property corners disturbed within the construction disturbance limits specified within the plans. All work necessary to reestablish property corners shall be paid for at the contract unit bid price per each (EA) for "Reestablish Property Corner".

Removal Quantities

Estimated removal and abandonment quantities are provided in the plans. Quantities provided have been calculated based on the measurements of the removal area. Station and offsets are provided for general project location only. The Contractor shall field verify removal quantities if they believe the tabulated information is in error. If an error is found, the Engineer shall be immediately notified.

Removal of driveway and/or alley gravel surfacing shall be considered incidental to the contract bid price for "Excavation, Unclassified" and no separate payment will be made for removal of gravel surfacing.

Plans quantity will be the basis for payment for removal items unless changes are directed by the Engineer during construction. If changes are directed, the actual quantities removed will be measured by the Engineer and will be paid for at the unit prices under the respective remove bid items. Payment for removal items, unless noted to be salvaged, shall be full compensation for removal and disposal at an approved waste disposal site. If an item is called out to be removed and salvaged, payment under the respective bid item shall be full compensation for the removal and return of the item to its owner, including coordination and transportation.

Waste Disposal Site

The Contractor will be required to furnish a site(s) for the disposal of construction/demolition debris generated by this project. Construction/demolition debris may not be disposed of within city, county or state rights of way.

The waste disposal site(s) shall be managed and reclaimed in accordance with the following from the general permit for highway, road, and railway construction/demolition debris disposal under the South Dakota Waste Management Program issued by SD DANR.

The waste disposal site(s) shall not be located in a wetland, within 200 feet of surface water, or in an area that adversely affects wildlife, recreation, aesthetic value of an area, or any threatened or endangered species.

If the waste disposal site(s) is located such that it is within view of any ROW, the following additional requirements shall apply:

1. Construction/demolition debris consisting of concrete, asphalt concrete, or other similar materials shall be buried in a trench completely separate from wood debris. The final cover over the construction/demolition debris shall consist of a minimum of 1 foot of soil capable of supporting vegetation. Waste disposal sites provided outside of the city or state ROW shall be seeded in accordance with natural resources conservation service recommendations. The seeding recommendations may be obtained through the appropriate county NRCS office.

The Contractor shall control the access to waste disposal sites not within city or state ROW through the use of fences, gates and placement of a sign or signs at the entrance to the site stating "no dumping allowed".

2. Concrete and asphalt concrete debris may be stockpiled within view of the ROW for a period of time not to exceed the duration of the project. Prior to project completion, the waste shall be removed from view of the ROW or buried and the waste disposal site reclaimed as noted above.

The requirements will not apply to waste disposal sites that are covered by an individual solid waste permit as specified in SDCL 34a-6-58, SDCL34a-6-1.13, and ARSD 74:27:10.06.

Failure to comply with the requirements stated above may result in civil penalties in accordance with South Dakota Solid Waste Law, SDCL 34a-6-1.31.

All costs associated with furnishing waste disposal site(s), disposing of waste, maintaining control of access (fence, gates, and signs), and reclamation of the waste disposal site(s) shall be incidental to the various contract items.

Clearing

Clearing shall be in accordance with Section 31.11.10 of the Standard Specifications. Extreme care shall be used by the Contractor to preserve all trees and other vegetation that lie outside the actual construction limits. Any materials such as trees, stumps, timbers, fence posts, delineators and other debris encountered during clearing operations shall be disposed of at the direction of the Engineer. The costs for all trees smaller than 6" in diameter, shrubs or other vegetation removed shall be included in the lump sum bid item for "Clearing & Grubbing".

Removal Of Asphalt Pavement

All asphalt concrete pavement designated for removal on the plans shall be removed and disposed of at an approved Contractor furnished disposal site. Costs for all labor, materials, machinery, transport and disposal shall be a part of the respective removal bid item.

Sawing In Existing Pavement

Pavement areas to be removed are shown on the drawings. These areas represent the final pavement sawcut and removal limits. The first pavement sawcut for asphalt shall be made at least 1 foot inside of the lines shown. Pavement to be removed next to the concrete curb and gutter shall have the first pavement sawcut at least 1 foot inside the lip of the curb and gutter. Sawcutting of the pavement areas shall be in accordance with the Standard Specifications. Items to be sawcut will include AC pavement, pans, sidewalks, curb and gutters, and miscellaneous concrete and asphalt items as shown on the plans. No separate payment will be made for sawing.

Right-Of-Way Removals

Landscaping, and other associated items located within the right-of-way to be removed during construction shall be removed and salvaged to the landowner. It is the Contractor's responsibility to contact and coordinate with the landowner the location of where these items are to be placed.

Pipeline Encasement

Where indicated on the plans or required by the Standard Specifications, pipe shall be encased with controlled low strength material. The controlled low strength material shall comply with Section 200 of the Standard Specifications. Encasement shall be completed in accordance with section 8AR.3 of the Standard Specifications. The pipe encasement, including all equipment, material, and labor will be paid for at the contract unit bid price per linear foot (LF) for "pipeline encasement".

Contractor will provide a concrete encasement mix design.

PVC Water Main

All water main of 12-inch diameter and smaller shall be restrained joint PVC pipe and shall conform to the requirements of AWWA C900, pressure class 235, DR 18 and the Standard Specifications Section 33.11.13, unless otherwise noted within these plans.

Regular bell and spigot PVC may be used at 6" diameter hydrant leads where there will be no pipe joint between the tee and the hydrant.

Water main shall be bedded with Type 1 Bedding Material in accordance with the detail provided in these plans and shall be incidental to the water main installation.

Type 1 Bedding Material

Passing 1-inch sieve	100%
Passing 3/4-inch sieve	90-100%
Passing 3/8-inch sieve	20-55%
Passing #4 sieve	0-10%
Passing #8 sieve	0-8%

Ductile Iron Water Main

Ductile Iron Pipe shall be ductile iron conforming to AWWA C151. Provide pipe in nominal 18- or 20-foot laying lengths. Pipe marking shall be plainly marked each length of straight pipe to identify the design pressure class or thickness class, the wall thickness, and date of manufacture. Mark the spigot end of restrained joint pipe to show clearly the required depth of insertion to the bell. Minimum wall thickness for pipe having push-on or mechanical joints, restrained joints, plain ends, or cast flange ends shall be Pressure Class 350. The minimum wall thickness pipe for having threaded flanges shall be Special Thickness class 53 per AWWA C151. Minimum wall thickness for pipe having grooved end joints shall be Class 53.

Water Main Fittings

All fittings shall be ductile iron with mechanical joints, unless otherwise noted, and shall be restrained. Pipe deflection at fittings shall be within tolerances recommended by the pipe and/or fitting manufacturer. Allowable deflection parameters shall be included in the pipe submittal and shall be clearly marked as such.

Water main top of pipe (TOP) elevations have been called out within these plans. The Contractor is responsible for installing the PVC pipe according to these elevation callouts.

Payment for thrust restraints on all PVC pipe shall be incidental to the fittings and water main bid items and no separate payment will be made.

Ductile Iron joints shall be iron push-on or mechanical joint fittings conforming to AWWA C110 with a rated working pressure of 350 psi.

Thrust Blocks

Thrust blocks are required as called for in the tables of thrust blocks within these plans and in the Standard Specifications.

Payment for thrust blocks shall be incidental to the fittings and water main bid items and no separate payment will be made.

Pipeline Warning Tape

Warning tape width for mains of 10-inch diameter and smaller shall be six inches. Warning tape width for mains of 12-inch diameter and greater shall be twelve inches.

Warning tape shall be non-traceable type. Warning tape shall be resistant to corrosive soil and intended for extended direct burial service. Tape shall meet A.P.W.A. national color code and be labeled, "Caution: Buried Water Below" with bold black letters for full length of tape. Warning tape shall be buried twelve inches above the water line.

Warning tape shall be incidental to the water main installation.

Fire Hydrants

Hydrants shall be set according to Detail W-02 for the water distribution mains.

Payment for fire hydrants shall include the auxiliary valve and box as called for in Section 33.11.13 of the Detailed Specifications and 6" pipe from tee to Fire Hydrant valve.

Connect To Existing Water Main

It is the Contractor's responsibility to verify location of the existing water main at the proposed connect to existing locations. It is the Contractor's responsibility to inform the Engineer of location and elevation prior to construction of the water main and fittings required to connect to the existing water main. All work necessary to determine the location of the existing water main shall be incidental to the contract bid item "Connect to Existing Water Main".

Connecting to existing water mains shall be completed per the Standard Specifications and as indicated within these plans.

All equipment, labor, materials and incidentals necessary for connecting to existing water main shall be included in the bid item "Connect to Existing Water Main" and paid for at the contract unit price per each.

Disinfection of Water Mains

The Contractor shall disinfect water mains in accordance with the Standard Specifications

The Contractor shall employ methods to keep the pipe as clean as possible during installation, including but not limited to: temporary capping of pipe sections as they are installed, swabbing the pipe with a 1% hypochlorite solution; and mechanical means such as hydraulically propelled foam pig

After disinfection, the Contractor shall remove the heavily-chlorinated water from the mains and neutralize.

All costs for cleaning, disinfection and flushing of all water mains shall be incidental to the installation of the water mains. No separate payment will be made.



Towey Design Group, Inc.
147 Chisholm Drive
Box Elder, SD 57719
605.600.3758

LOGO:



**DEADWOOD RAILROAD AVENUE
WATER MAIN EXTENSION
DEADWOOD, SOUTH DAKOTA**

REVISIONS:
35% DESIGN PLANS
95% DESIGN PLANS

JOB NUMBER: 24-010
DESIGNED BY: BK
DRAWN BY: BK/NR
SURVEYED BY:
SURVEY DATE:

SHEET NAME: GENERAL NOTES
SHEET NO: 4

19-24-010 - 000 Redwood Avenue, Suite 100, Deadwood, SD 57719-0001, 605.600.3758, 2/19/2025, 8:15am
 C:\BPA\AS - 000\PROJECT

Neutralization of Heavily-Chlorinated Water

Dechlorination shall be completed in accordance with AWWA C655 and the Project Specifications. Heavily-chlorinated water used to disinfect all water mains shall be neutralized prior to release. The heavily-chlorinated water shall be neutralized by introducing Captor NSF, or approved equal, at the discharge from a hydrant using approved dechlorination equipment. At the option of the Contractor, the heavily-chlorinated water shall be contained and transported to an approved location for land application. The Contractor shall remain responsible for meeting all requirements of the standard specifications for required flow and minimum flow duration to flush pipelines and surface water quality standards. Neutralization of the heavily-chlorinated water shall be incidental to the installation of all water mains.

Water Main Pressure Testing

All testing shall be completed according to Section 33.11.13 of the Standard Specifications. All costs for pressure testing and final connection shall be incidental to the installation of the various water main diameters and included in their respective bid items.

The test pressure in the project area shall be 180 psi. 350 psi for Ductile Iron pipes.

Trench Check Dam

The Contractor shall place within the trench a compacted cohesive clay check dam. Check dam locations shall be as indicated on the plans. During construction check dam locations may be moved due to field conditions upon notification to the Engineer. The adjusted location shall be recorded. The check dam shall extend from the bottom of the excavation through the bedding material to the backfill and shall extend completely to each trench sidewall. The check dam is used as a means to prevent the conveyance of water through the trench bedding. Compacted cohesive clay shall consist of material that contains a minimum of 25% minus no. 200 sieve material, with 70% passing a 3/4-inch sieve and a minimum P.I. of 10%. The material shall consist of clay, silty sand, or silty clay. If the normal excavated material is not suitable for construction of the check dam, then the Contractor shall obtain material from outside sources. Check dam installation and material shall be considered as incidental to the water pipe installation.

Storm Sewer Pipe

Install length for all storm sewer pipes are called out by the measurement taken from the downstream box inside wall to the upstream box inside wall and rounded up to the nearest foot.

The install length is rounded up to the nearest even number increment (2, 4, 6, etc) in the table of storm sewer pipe. The length called out in the table of storm sewer pipe is the length called out in the bid tab. The laying length of tees and bends has been subtracted from the install lengths and quantity tables.

Pipes are designed linearly from center of junction box to center of box. In cases where the pipe is not perpendicular to the box wall, The Contractor shall match center of pipe to the horizontal center of the box wall.

The design intent of the storm sewer pipe layout is to have a minimum of 1-foot of embankment over all storm pipes. This may not be the case at major storm pipe crossings and in longitudinal runs where pipe slope is critical. The Contractor is advised to take precautions to protect the integrity of shallow storm pipes.

Storm sewer may be either reinforced concrete pipe (RCP) or ADS HP Storm. The storm sewer layout identified in these plans is based on RCP. If an alternate material is supplied, it is the responsibility of the Contractor and Material Supplier to provide any proposed layout modifications for review and approval.

RCP with a diameter of 30" and smaller shall be Class 3. RCP with a diameter of 36" and greater shall be Class 2. Bedding for reinforced concrete pipe shall be Class C in accordance with the SDDOT Standard Specifications for Roads and Bridges 2015 Edition.

Bedding for HP Storm shall be in accordance with the trench detail for HDPE Storm Pipe included within these plans.

Reinforced Concrete Storm Inlets

Type B inlet frames and grates shall be Neenah R-3067V or approved equal. Construction details for the various types of inlets will be in accordance with Standard Details. Precast concrete collars are allowed; no additional payment will be made.

Payment for storm inlets will be full compensation for excavation, backfill, labor, all materials including concrete and reinforcing steel, frames, grates, covers, castings, and incidentals necessary for a complete storm inlet structure. Payment will be made on a per each basis for each individual box under the specific size listed in the bid tab.

Storm Area Inlet

A 2' x 3' Area Inlet (or similar larger area inlet) shall be installed in the location shown in these plans. Installation shall include the reinforced concrete box, frame and grate, and a concrete collar constructed per the details shown in these plans. The cast frame and grate shall be a SDDOT Type E frame and grate (SDDOT Standard Plate 670.86) or approved equal. Payment for the storm area inlet will be full compensation for excavation, backfill, labor, all materials including reinforced concrete box, frames, grates, concrete collar, and incidentals necessary for a complete structure. Payment will be made under the contract bid item "2' X 3' Area Inlet" at the unit price per each.

Culvert Inlet and Outlets

Additional minor grading to shape slopes and provide positive drainage may be necessary at culvert inlets and outlets. No extra payment will be made for this operation.

Concrete Pipe Connections

Pipe connections to existing pipes, manholes, junction boxes and drop inlets shall be done by breaking a hole into the existing structure and inserting the pipe. A concrete collar shall then be poured around the pipe in the area of the connection.

When it is not possible to use a normal joint (male-female ends), connections to existing pipe shall be made by placing a 2' wide by 6" thick M-6 concrete collar around the outside of the connection. The concrete collar shall be reinforced with 6x6 W2.9 x W2.9 wire mesh.

All costs for constructing the concrete collars including materials and labor shall be incidental to the contract unit price per foot for the corresponding bid item.

Granular Base Material

Aggregates for granular base material shall conform to the requirements for aggregate base course or limestone ledge rock base course as specified in the Standard Specifications.

Placement of granular base material shall be in accordance with the Standard Specifications.

Estimated quantities were based upon an assumed in place density of 150 pounds per cubic foot.

Granular base material placed for sidewalk construction shall be considered incidental to the sidewalk bid item per the standard specifications unless otherwise specified. All other granular base material shall be paid for under the bid item for "Aggregate Base Course."

Gravel Surfacing

Aggregates for gravel surfacing shall conform to the requirements for aggregate base course or limestone ledge rock base course as specified in Section 32.11.23 of the Standard Specifications.

Placement of gravel surfacing shall be in accordance with the Standard Specifications.

Estimated quantities were based upon an assumed in place density of 150 lb/cu ft placed 6-inches thick.

Payment for gravel surfacing will be made at the contract unit price per ton for "Gravel Surfacing, Permanent".

Portland Cement Concrete

All concrete shall be Class M6 unless otherwise specified and approved by the Engineer. The Contractor may utilize up to 20% fly ash in the mix design for class M6 concrete.

Concrete Curb and Gutter

Concrete curb and gutter construction and measurement shall be in accordance with Section 32.16.13 of the Standard Specifications.

Payment for type B66 curb and gutter will be made at the contract unit price per linear foot for "Concrete Curb & Gutter, Type B66." payment for type P6 curb and gutter will be made at the contract unit price per linear foot for "Concrete Gutter, Type P6".

Curb Ramps and Openings

Curb ramps and openings shall be constructed in accordance with the details in this plan set, at the locations shown on the drawings or as required by the Engineer. No separate payment will be made for curb ramps and openings.

Asphalt Concrete

The Contractor may utilize up to 15% rap within the asphalt mix design. Estimated quantities were based upon an assumed in place density of 150 lb./cu ft.

6-inch Reinforced Portland Cement Concrete Pavement

Portland Cement Concrete Pavement shall conform to the requirements of Section 32.13.13 of the Standard Specifications. The final finish shall be with a carpet drag drawn over the surface in a longitudinal direction.

Brooming may be used on irregular areas as approved by the Engineer. Curing shall be accomplished utilizing the Liquid Membrane Curing Compound Method unless otherwise approved by the Engineer. The pavement surface shall be tested with a 10 Foot Straightedge with the permissible longitudinal and transverse surface deviation being 1/4 inch in 10 feet. Joints shall be sealed with a hot-poured elastic joint sealer. Joints in the adjacent curb and gutter shall be sealed in accordance with Standard Detail RG006 and RG007.

Sidewalk

Sidewalk shall be constructed per Section 32.06.10 of the Standard Specifications. The sidewalk identified to be constructed at handicapped ramp locations shall be constructed with 5 inches of concrete on 4 inches of aggregate base course. The 5" concrete sidewalk will be paid for under the bid item for "Concrete Sidewalk, 5" Nonreinforced" and the 4 inches of aggregate base course will be paid for under the bid item for "Aggregate Base Course". All other sidewalk shall be 4 inches thick over 2" of aggregate base course which is incidental to the sidewalk item.

Expansion Joints in Concrete Pavement

Concrete driveways and sidewalk placed adjacent to existing concrete or buildings/structures shall have preformed expansion joint filler placed along the new/existing interface.

Preformed expansion joint filler shall be considered incidental to the various concrete bid items. No separate payment will be made.

Topsoil

The Contractor is required to salvage topsoil from within the limits of the project and stockpile on site. Salvaging and stockpiling of topsoil will be paid for at the contract unit price per cubic yard for "Excavation, Unclassified." Payment for placing topsoil will be paid for at the contract unit price per cubic yard for "Topsoil, Place." Plans quantity will be the basis of payment for "Topsoil, Place" unless changes are ordered by the Engineer.

The estimated amount of topsoil to cover the areas designated to receive seed, to a minimum depth of 6 inches, is given in the estimate of quantities assuming no shrinkage. Contractor furnished topsoil will not be required.

A portion of the salvaged topsoil quantity shall be used in the construction of topsoil berms. See the erosion and sediment control notes and layouts for additional information. Payment for construction of the topsoil berms shall be considered incidental to the "Excavation, Unclassified" bid item.

Permanent Seeding, Fertilizing and Mulching

All disturbed areas that will not be paved, graveled, or sodded shall be permanently seeded, fertilized, and fiber mulched according to the Standard Specifications. Seed shall be placed by drilling methods on all areas.

Seed mix shall be the road ditch mix per the Standard Specifications.

In areas where the road ditch mix is used, a cover crop of winter wheat shall be applied at 10 lbs/ acre if seeded between August 1 and November 30. Spring wheat shall be used if seeding is completed between December 1 and July 31. Watering will be required according to Section 32.92.19 of the Standard Specifications. Water shall be incidental to the contract bid item, "Seeding, Fertilizing, & Mulching".

Plans quantity will be paid without further measurement.

Geogrid Subgrade Reinforcement

A quantity of geogrid subgrade reinforcement is included in the estimate of quantities for subgrade stabilization at possible unstable areas. Geogrid subgrade reinforcement shall be Mirafi BXG120 or approved equal.

This work item requires pre-authorization of the Engineer to be eligible for payment. Payment will be based on field measurement of quantities.



Towey Design Group, Inc.
 147 Chisholm Drive
 Box Elder, SD 57719
 605.600.3758

LOGO



DEADWOOD RAILROAD AVENUE
WATER MAIN EXTENSION
DEADWOOD, SOUTH DAKOTA

REVISIONS:

35% DESIGN PLANS
 95% DESIGN PLANS

JOB NUMBER: 24-010

DESIGNED BY: BK
 DRAWN BY: BK/NR
 SURVEYED BY:
 SURVEY DATE:

SHEET NAME:

GENERAL NOTES

SHEET NO:

5

P:\14-010 - 100 Railroad Avenue Water Main Extension\Drawings\Sheet\LEGEND.dwg 2/17/2025 8:17am
 C:\Users\jdoon\OneDrive\Documents\1500018

EXISTING

	BORE HOLE		ASPHALT
	TRANSFORMER		BUILDING
	ELECTRIC / COMM BOX		CENTERLINE
	FIRE HYDRANT		COMMUNICATION LINE
	GATE VALVE		CONCRETE
	SANITARY SEWER CLEANOUT		CURB & GUTTER
	SANITARY SEWER MANHOLE		GAS LINE
	SIGN		EDGE OF GRAVEL
	STREET LIGHT		FENCE - BARB
	TYPE B		FENCE - CHAINLINK
	TYPE E		FENCE - WOOD
	TYPE S		MAJOR CONTOUR
	TREE		MINOR CONTOUR
	GUY		OVERHEAD POWER LINE
			POWER CONDUIT
			PROPERTY LINE
			RIGHT OF WAY LINE
			RIPRAP
			SANITARY SEWER MAIN
			SANITARY SEWER SERVICE
			SECTION LINE
			SIDEWALK
			STORM SEWER
			WATER MAIN
			WATER SERVICE

PROPOSED

	BEND		ASPHALT
	BORE HOLE		COMMUNICATION LINE
	CAP		CONCRETE
	CROSS		CURB & GUTTER
	DEFLECTION COUPLING		DEMOLITION
	FIRE HYDRANT		DIRECTION OF FLOW
	GATE VALVE		DRAINAGE LINE
	LEFT TURN LANE		EXCAVATION LIMITS
	POST INDICATOR VALVE		EXISTING PROPERTY LINE
	REDUCER		EXISTING SANITARY SEWER MAIN
	RIGHT TURN LANE		EXISTING WATER MAIN
	SANITARY SEWER CLEANOUT		FOUNDATION DRAIN
	SANITARY SEWER MANHOLE		GAS LINE
	SIGN		GRAVEL FILTER SOCKS
	STREET LIGHT		MAJOR CONTOUR
	TEE		MINOR CONTOUR
	TYPE B		PAVEMENT MARKING
	TYPE E		PERIMETER PROTECTION
	TYPE S		POWER CONDUIT
			PROPERTY LINE
			ROOF DRAIN
			RIGHT OF WAY LINE
			RIPRAP
			SANITARY SEWER MAIN
			SANITARY SEWER SERVICE
			SECTION LINE
			SETBACK LINE
			SIDEWALK
			SILT FENCE
			STORM SEWER
			STRAW WATTLE
			TOP SOIL BERM
			WATER MAIN
			WATER SERVICE



Towey Design Group, Inc.
 147 Chisholm Drive
 Box Elder, SD 57719
 605.600.3758

LOGO:

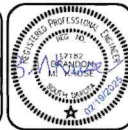

DEADWOOD RAILROAD AVENUE
WATER MAIN EXTENSION
DEADWOOD, SOUTH DAKOTA

REVISIONS:
 35% DESIGN PLANS
 95% DESIGN PLANS

JOB NUMBER: 24-010
 DESIGNED BY: BK
 DRAWN BY: BK/NR
 SURVEYED BY:
 SURVEY DATE:

SHEET NAME:
LEGEND

SHEET NO:
 6

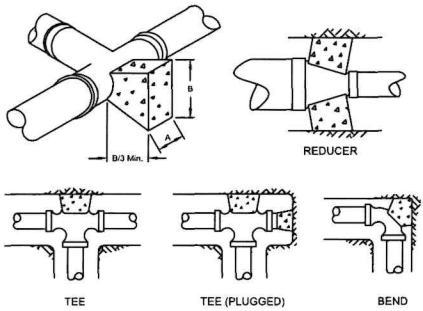

THRUST BLOCKING FOR WATER MAIN FITTINGS

12" PVC		8" PVC		6" PVC	
FITTINGS	RESTRAINED LENGTHS	FITTINGS	RESTRAINED LENGTHS	FITTINGS	RESTRAINED LENGTHS
BENDS					
11 1/2'	3'	11 1/2'	2'	11 1/2'	2'
22 1/2'	5'	22 1/2'	3'	22 1/2'	3'
45'	9'	45'	6'	45'	5'
90'	21'	90'	15'	90'	11'
TEE'S					
12" x 12"	28'	8" x 8"	10'	6" x 6"	1'
12" x 8"	1'	8" x 6"	1'		
12" x 6"	1'				
VALVE/CAP	62'	VALVE/CAP	43'	VALVE/CAP	33'
REDUCERS/INCREASERS					
12" x 8"	33'	8" x 6"	18'		
12" x 6"	45'				
VERTICAL OFFSETS					
45'					
UPPER BEND	35'	UPPER BEND	---	UPPER BEND	---
LOWER BEND	7'	LOWER BEND	---	LOWER BEND	---

RESTRAINING REQUIREMENTS
 ALL FITTINGS, VALVES, AND PIPE JOINTS WITHIN THE SPECIFIED RESTRAINED LENGTHS LISTED BELOW SHALL BE RESTRAINED.

INSTALLATION CONDITIONS USED FOR CALCULATIONS:

1. SOIL TYPE = CL, GRAN, FILL
2. TRENCH TYPE = 5
3. TEST PRESSURE = 150 PSI
4. SAFETY FACTOR = 1.5:1
5. DEPTH BURY = 6.0 FT.
6. TEE RESTRAINTS WERE CALCULATED W/RESTRAINT LENGTHS OF 5' IN EACH DIRECTION ALONG THE RUN OF TEE.

NOTE:
 CALCULATIONS FOR RESTRAINED LENGTHS WERE DERIVED FROM EBAA IRON INC. SOFTWARE. WHERE RESTRAINT LENGTHS CAN NOT BE ACHIEVED THRUST BLOCKS SHALL BE UTILIZED.

OPERATING PRESSURE (psi)	150
SOIL BEARING CAPACITY (psf)	1500
FACTOR OF SAFETY	2

TEES AND DEAD ENDS					
MIN. AREA (sq)	A (ft)	B (ft)	T (ft)	MIN. VOL. (cy)	
4	3.70	2.70	1.40	1.50	0.21
6	7.50	4.00	1.90	1.50	0.42
8	12.50	5.20	2.50	1.50	0.72
10	19.40	6.30	3.10	1.50	1.09
12	27.40	7.50	3.70	1.50	1.54
14	36.80	8.60	4.30	1.50	2.05
16	47.60	9.80	4.90	2.00	3.56
18	59.80	10.90	5.50	2.00	4.44
20	73.30	12.10	6.10	2.00	5.47
24	104.60	14.60	7.20	2.00	7.79

90 DEGREE BENDS					
MIN. AREA (sq)	A (ft)	B (ft)	T (ft)	MIN. VOL. (cy)	
4	5.20	3.30	1.60	1.50	0.29
6	10.60	4.70	2.30	1.50	0.60
8	18.20	6.10	3.00	1.50	1.02
10	27.40	7.50	3.70	1.50	1.54
12	38.80	8.90	4.40	1.50	2.19
14	52.10	10.30	5.10	1.50	2.92
16	67.30	11.70	5.80	2.00	5.03
18	84.50	13.00	6.50	2.00	6.26
20	103.70	14.50	7.20	2.00	7.73
24	147.90	17.20	8.60	2.00	10.98

45 DEGREE BENDS					
MIN. AREA (sq)	A (ft)	B (ft)	T (ft)	MIN. VOL. (cy)	
4	2.80	2.40	1.20	1.50	0.16
6	5.80	3.50	1.70	1.50	0.33
8	9.90	4.50	2.20	1.50	0.55
10	14.90	5.60	2.70	1.50	0.84
12	21.00	6.60	3.20	1.50	1.17
14	28.20	7.50	3.80	1.50	1.58
16	36.40	8.50	4.30	2.00	2.71
18	45.80	9.60	4.80	2.00	3.41
20	56.10	10.60	5.30	2.00	4.16
24	80.10	12.80	6.30	2.00	5.97

22.5 DEGREE BENDS					
MIN. AREA (sq)	A (ft)	B (ft)	T (ft)	MIN. VOL. (cy)	
4	1.4	0.80	1.50	0.08	
6	2.8	1.20	1.50	0.17	
8	5.0	1.60	1.50	0.28	
10	7.6	1.90	1.50	0.42	
12	10.7	2.30	1.50	0.60	
14	14.3	2.70	1.50	0.81	
16	18.6	3.00	2.00	1.38	
18	23.3	3.40	2.00	1.74	
20	28.6	3.80	2.00	2.14	
24	40.8	4.50	2.00	3.03	

11.25 DEGREE BENDS AND HD COUPLINGS					
MIN. AREA (sq)	A (ft)	B (ft)	T (ft)	MIN. VOL. (cy)	
4	0.7	1.20	0.60	1.50	0.04
6	1.5	1.70	0.90	1.50	0.09
8	2.5	2.30	1.10	1.50	0.14
10	3.8	2.80	1.40	1.50	0.22
12	5.4	3.40	1.80	1.50	0.30
14	7.2	3.80	1.90	1.50	0.40
16	9.3	4.50	2.10	2.00	0.70
18	11.7	4.80	2.40	2.00	0.87
20	14.4	5.40	2.70	2.00	1.08
24	20.5	6.50	3.20	2.00	1.54

P:\24-010 - 888 - Deadwood Avenue Water Main Extension\24-010-001 - Engineering\Drawings\Sheet\112525 - WRTS.dwg 2/17/2025 8:17am
 COLOR PLANS - SHEET TOOLS



Towey Design Group, Inc.
 147 Chisholm Drive
 Box Elder, SD 57719
 605.600.3758

LOGO:

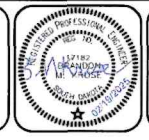

DEADWOOD RAILROAD AVENUE
WATER MAIN EXTENSION
DEADWOOD, SOUTH DAKOTA

REVISIONS:
35% DESIGN PLANS
95% DESIGN PLANS

JOB NUMBER: 24-010
DESIGNED BY: BK
DRAWN BY: BK/NR
SURVEYED BY:
SURVEY DATE:

SHEET NAME: SECTIONS
SHEET NO: 7

COUNTY OF DEER BROOK

PROJECT: 24-010 - WDM Extension Water Main Extension 1/4" = 1'0" Engineering Stationing: 24+00.00 to 24+500.00 DATE: 2/17/2024 8:17am

Line Item	Description of Item	Qty.	Unit
General			
100	Mobilization	1	LS
101	Incidental Work	1	LS
102	Material Testing	1	LS
103	Traffic Control	1	LS
104	Construction Staking	1	LS
105	Erosion and Sediment Control	1	LS
Removals			
200	Remove Concrete Sidewalk	112.0	SF
201	Remove Fire Hydrant	1.0	EA
202	Remove AC Pavement	3,307.2	SY
203	Remove Concrete Curb and Gutter	89.0	LF
204	Remove Existing Storm Sewer Inlet	5.0	EA
205	Remove Existing Storm Sewer Pipe	290.0	LF
206	Remove Existing Asphalt Millings/ Gravel	2,138.3	SY
Excavation			
300	Unclassified Excavation	1.0	LS
301	Topsoil: Salvage, Stockpile and Place	1.0	LS
302	Seeding, Fertilizing, & Mulching	1.0	LS
Water			
400	Fire Hydrant Assembly	8.0	EA
401	6" PVC Water Main C-900, DR-18	99.0	LF
402	8" PVC Water Main C-900, DR-18	73.0	LF
403	12" PVC Water Main C-900, DR-18	4,501.0	LF
405	8" 45° Bend	1.0	LF
406	8" 90° Bend	1.0	LF
407	12" High Deflection Coupling	18.0	EA
408	12" 11.25° Bend	21.0	EA
409	12" 22.5° Bend	8.0	EA
410	12" 45° Bend	2.0	EA
411	8"x6" Tee	2.0	EA
412	12"x6" Tee	7.0	EA
413	12"x8" Tee	2.0	EA
414	12"x10" Tee	1.0	EA
415	12"x12" Tee	2.0	EA
416	6" Gate Valve	1.0	EA
417	8" Gate Valve	2.0	EA
418	12" Gate Valve	17.0	EA
419	12" Cap	2.0	EA
420	Pipeline Encasement	44.0	LF
421	Connect to Existing Watermain	4.0	EA
Storm Sewer			
600	2' x 3' Type B Inlet	6.0	EA
601	3' x 4' Type B Inlet	2.0	EA
602	18" Storm Pipe	330.0	LF
603	24" Storm Pipe	9.0	LF

Line Item	Description of Item	Qty.	Unit
604	Connect to Existing 24" RCP	1.0	EA
Street			
700	Aggregate Base Course, 6"	1,116.2	TON
701	Class E Type 1 PG 64-28 Asphalt Paving, 5"	937.6	TON
702	Asphalt Millings	476.3	TON
703	Concrete Fillets and Drain Pan, 6" Reinforced	492.0	SY
704	Curb and Gutter, Type B66	728.0	LF
705	Curb and Gutter, Type D46	42.0	LF
706	Concrete Sidewalk	112.0	SF
707	Paint Striping	71.0	EA
Erosion Control			
800	Inlet Protection	8.0	EA
801	Silt Fence	2,000.0	LF
802	9" Sediment Control Wattles	-	LF
803	Vehicle Tracking Control	2.0	EA
804	Concrete Wash Out Area	1.0	EA



Towey Design Group, Inc.
147 Chisholm Drive
Box Elder, SD 57719
605.600.3758

LOGO



DEADWOOD RAILROAD AVENUE
WATER MAIN EXTENSION
DEADWOOD, SOUTH DAKOTA

REVISIONS:
35% DESIGN PLANS
95% DESIGN PLANS

JOB NUMBER: 24-010
DESIGNED BY: BK
DRAWN BY: BK/NR
SURVEYED BY:
SURVEY DATE:

SHEET NAME:
QUANTITIES

SHEET NO:
8

P:\24-010 - 240 Railroad Avenue Water Main Extension\24-010-001 - Engineering\Drawings\24010\24010.dwg 2/11/2025 8:17am
 65014 P:\24-010 - 240 Railroad Avenue Water Main Extension\24-010-001 - Engineering\Drawings\24010\24010.dwg 2/11/2025 8:17am

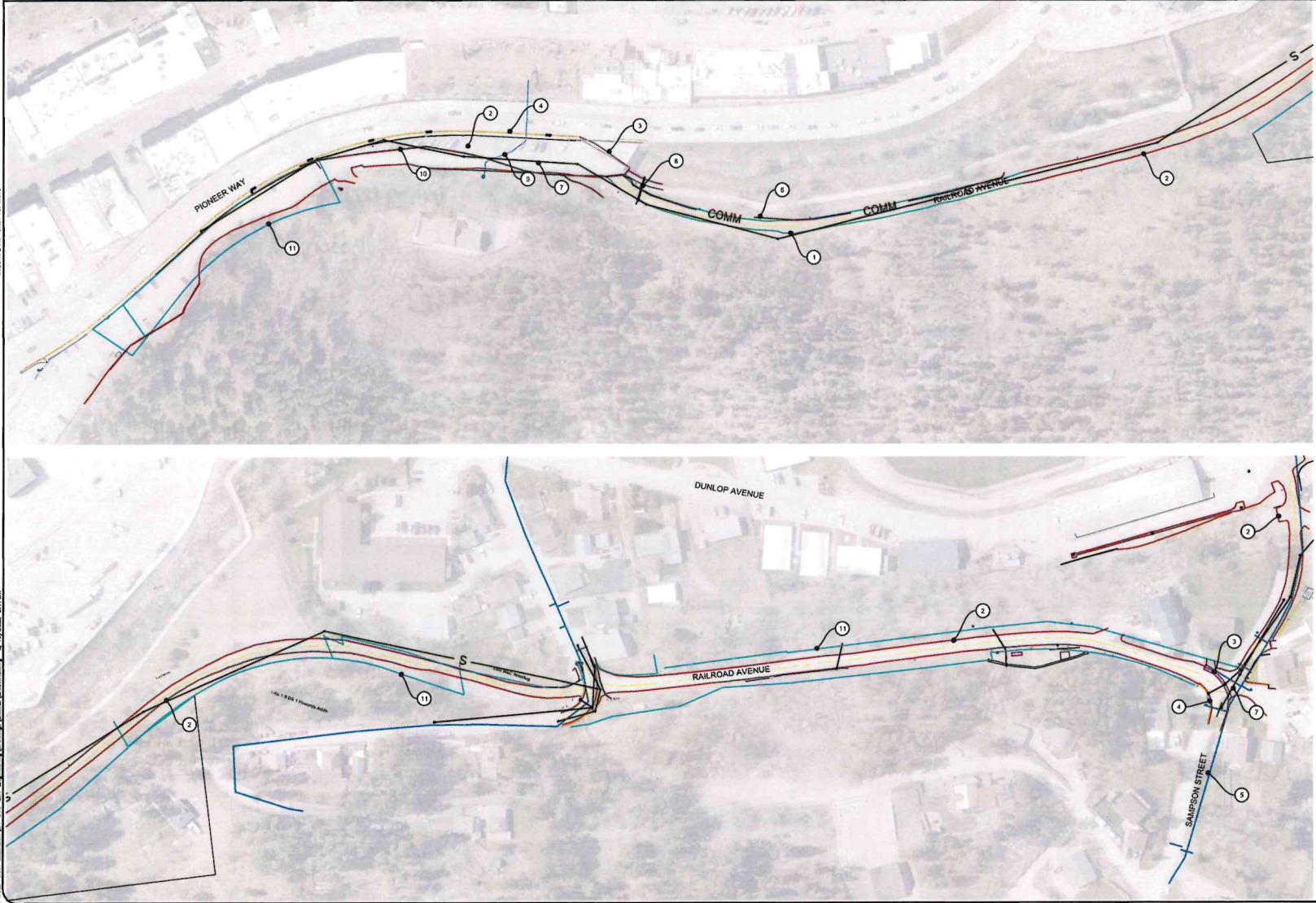

- ① EXISTING GRAVEL LINE
- ② EXISTING ASPHALT
- ③ EXISTING CONCRETE
- ④ EXISTING CURB AND GUTTER
- ⑤ EXISTING WATER LINE
- ⑥ EXISTING COMM LINES
- ⑦ EXISTING SEWER MAIN
- ⑧ EXISTING STORM SEWER
- ⑨ EXISTING 1/2" COPPER SERVICE LINE
- ⑩ EXISTING COMM LINE (UG)
- ⑪ EXISTING PROPERTY LINE

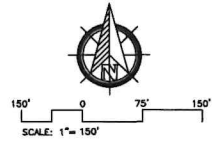

TDG

Towey Design Group, Inc.
 147 Chisholm Drive
 Box Elder, SD 57719
 605.600.3758

LOGO:



DEADWOOD RAILROAD AVENUE
 WATER MAIN EXTENSION
 DEADWOOD, SOUTH DAKOTA

REVISIONS:
35% DESIGN PLANS
95% DESIGN PLANS

JOB NUMBER: 24-010
DESIGNED BY: BK
DRAWN BY: BK/NR
SURVEYED BY:
SURVEY DATE:

SHEET NAME: EXISTING CONDITIONS
SHEET NO: 9

PLAN-410 - 000 Bidder Name: Job: Estimate: 14-016-001 Description: (Township) Street(s) Location: WY85E Hwy 2/17/2025 8:12am COLORADO, CREV-1000.CDT

OWNER REPRESENTATIVE

Company: City of Deadwood, SD
Contact: Kevin Kuchenbecker, Planning and Zoning Director and Historic Preservation Officer
Address: 108 Sherman Street
Address: Deadwood, SD 57732
Email: kevin@cityofdeadwood.com
Phone: 605.578.2082

CONTRACTOR

Company: TBD
Contact:
Address:
Address:
Email:
Phone:

DESIGN ENGINEER

Company: Towey Design Group, Inc.
Contact: Brandon Kruse, PE #17182
Address: 147 Chisholm Drive
Address Box Elder, SD, 57719
Email: brandon@toweydesigngroup.com
Phone: 605.600.3758

PROJECT DESCRIPTION

This project consists of the installation of approximately 1 mile of water main. The installation of storm sewer along Sampson Ave. The reconstruction of the intersection of Railroad Ave and Sampson Street.

SOILS

Consult the geotechnical report for more complete soils information. The geotechnical report is provided in the bidding documents. Generally the soils are classified as a Silty Lean Clay with Gravel.

EXISTING SITE CONDITIONS

- Are wetlands an issue? No
- If wetlands are an issue, has a determination been made by the US Army Corps of Engineers?
- Does the State Historical Preservation Office (SHPO) need to review these plans? No
- Does the SD Game, Fish, and Parks need to review these Plans? No
- Does the US Fish and Wildlife Service need to review these plans? No

ADJACENT AREAS

Adjacent areas near the start of the project consist of parking lot and highway on each side of the project. The portion down Railroad Ave consists of Whitewood Creek and hill areas, with mixed in single family residential housing.

AREA FOR STOCKPILE AND STORAGE

Any excavated materials to be reused may be stockpiled within the project limits at a location chosen by the Contractor and approved by the Owner and Engineer. Excess excavated materials are to be hauled off site. Stockpiles of excavated materials shall be protected by a silt fence where the silt fence shall be placed at a minimum of 8' from the toe of the pile and seeded with a temporary cover crop.

STORMWATER MANAGEMENT CONSIDERATIONS

Stormwater will generally flow toward the creek in all directions. Storm sewer networks drain directly to the Creek from various streets and parking lots.

AREAS DISTURBED

The anticipated total surface area to be disturbed is approximately 1.58 acres.

SEDIMENT CONTROL MEASURES

The intent of this project generally includes: concrete washout areas, vehicle tracking control pads, silt fence, sediment control wattles, gravel filter socks, inlet sedimentation protection, temporary sediment trap, and topsoil berm if desired.

NOTICE OF INTENT

The Contractor will be responsible for submitting the required documents to SDDANR. The Contractor will be required to secure the necessary permits through SDDANR. The Contractor shall coordinate efforts with City staff to allow time for the City to sign any and all documents as the Owner of the project. The Notice of Intent (NOI) will be submitted by the Owner. Following completion of the project, the Owner will be responsible for submitting a Notice of Termination (NOT). The Contractor will be responsible to submit any required documentation to the Owner for the NOI and NOT submittals.

SCHEDULE

The following is the Engineer's proposed order of project sequencing for the project. This is a theoretical schedule only. It is the Contractors responsibility to develop their own schedule if they would like to utilize a different sequencing, they shall submit that to the Engineer and City for approval.

- April of 2025 - Bid letting of the project.
- October of 2025 - All asphalt paving completed as required based on asphalt availability.
- November of 2025 - Final Completion

Erosion control measures installed with the project will remain in place and removed once the site has become stabilized.

MAINTENANCE

All paved streets and/or parking lots adjacent to the site shall be cleaned at the end of each working day. All construction traffic leaving the site shall exit via a vehicle tracking control pad.

The Prime Contractor shall assure that qualified personnel inspect the site at least once every 7 calendar days and within 24 hours of the end of a storm that is one-half (0.5) inch or greater to confirm plan compliance. A report summarizing the areas inspected, name(s) and title(s) of personnel making the inspection, the date(s) of the inspection, major observations, and corrective actions taken shall be made and retained as part of the plan for at least three (3) years. Such reports shall identify any incidents of non-compliance. Where an inspection does not identify incidents of non-compliance, the report shall contain a certification that the site is in compliance with the plan and permit.

PERMANENT STABILIZATION MEASURES

All disturbed areas from grading operations shall be seeded with a temporary cover crop.

SPILL PREVENTION/CONTROL PRACTICES

- For all hazardous materials stored on site, the manufacturer's recommended methods for spill clean-up will be clearly posted. Site personnel will be made aware of the procedures and the locations of the information and clean-up supplies.
- Appropriate clean-up materials and equipment will be maintained by the Contractor in the material storage area onsite. As appropriate, materials and equipment may include items such as: brooms, dust pans, mops, rags, gloves, goggles, kitty litter, sand, sawdust, and plastic and metal trash containers specifically for clean-up purposes.
- All spills will be cleaned immediately after discovery and the materials disposed of properly.
- The spill area will be kept well-ventilated and personnel will wear appropriate protective clothing to prevent injury from contact with any hazardous substances.
- After a spill, a report will be prepared describing the spill, what caused it, and the clean-up measures taken. The spill prevention plan will be adjusted to include measures to prevent this type of spill from recurring, as well as clean-up instructions in the event of recurrences.
- The Contractor's Site Superintendent, responsible for day-to-day operations, will be the spill prevention and clean-up coordinator. The Contractor is responsible for ensuring that the Site Superintendent has had appropriate training for hazardous materials handling, spill management, and clean-up.

SOIL STABILIZATION

After construction begins, soil stabilization shall be applied within 14 days to all disturbed areas that may not be final grade but will remain dormant (undisturbed) for periods longer than an additional 21 calendar days. Within 14 days after final grade is reached on any portion of the site, permanent or temporary soil stabilization shall be applied to disturbed areas and soil stockpiles. Maximum time limits of land exposures for selection of erosion controls:

Erosion Control	Method	Maximum Allowable Period of Exposure (months)
Surface Roughening*		1
Mulching		12
Temporary Revegetation		12-24
Permanent Revegetation		24 or more
Soil Stockpile Revegetation		2
Early Application of Road Base		1

*The surface roughening erosion control may be extended to a maximum of three (3) months on a case basis if the City Inspector has determined that the site demonstrates the following:

- Appropriate soil conditions exist for the methods of control.
- Disturbed areas will be seeded and mulched within three (3) months
- Seasonal planting limitations exist.
- Soil stabilization method has demonstrated its effectiveness.

DEWATERING

Dewatering operations are expected during the majority of this project. It is the Contractors responsibility to submit for the general dewatering permit from SD DENR. Refer to the General Notes Pages and the Standard Specification.

EROSION AND SEDIMENT CONTROL MEASURES

PERIMETER PROTECTION (PP)

Perimeter protection shall be installed at locations shown on the drawings or as directed by the Engineer, to retain sediment from being transported off the project site. Perimeter protection may be constructed with silt fence or sediment control wattles. Perimeter protection shall be inspected in accordance with the SWPPP.

SILT FENCE (SF)

Silt fence (Low Flow: 20-70 gal/min/sf or High Flow 71-145 g/min/sf) shall be placed at the locations noted in the drawings and at locations that will minimize siltation of adjacent streams, lakes, dams, or drainage areas as determined by the Engineer during construction.

MUCKING SILT FENCE

Mucking silt fence shall consist of removing muck trapped by the silt fence and spreading the material evenly over the adjacent area to conform to the existing grade. The Contractor shall remove muck when the surface of the muck is at approximately 1/3 the height of the silt fence.

SEDIMENT CONTROL WATTLES (SCW)

Sediment control wattles can be used for perimeter control, inlet protection, check dams, slope protection, etc. and shall be installed at locations as shown on the drawings and at locations determined by the Engineer during construction.

The Contractor shall provide certification that the sediment control wattles do not contain noxious weed seeds. For compost socks the contractor shall also provide certification that the compost used is free from noxious weed seeds.

The Contractor shall remove sediment trapped by the wattle when the surface of the sediment reaches one-half the height of the exposed wattle. Damaged areas should be repaired immediately until the vegetation is established and growing through the material.

EROSION CONTROL BLANKET (ECB)

Erosion control blanket shall be installed at locations as shown on the drawings and at locations determined by the Engineer during construction.

Erosion control blankets are placed into the following categories:

- Type 1 - used for temporary stabilization of slopes of less than 10H:1V, Not allowed in channel applications;
- Type 2 - used for temporary stabilization of slopes of 3H:1V or less, can be used in low gradient ditches and channels;
- Type 3 - used for temporary stabilization of slopes of 2H:1V or less, used in ditches and channels; and
- Type 4 - used for temporary stabilization of slopes of 1H:1V or less, used in ditches and channels.



Towey Design Group, Inc.
147 Chisholm Drive
Box Elder, SD 57719
605.600.3758

LOGO:

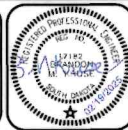

DEADWOOD RAILROAD AVENUE
WATER MAIN EXTENSION
DEADWOOD, SOUTH DAKOTA

REVISIONS:
35% DESIGN PLANS
95% DESIGN PLANS

JOB NUMBER: 24-010
DESIGNED BY: BK
DRAWN BY: BK/NR
SURVEYED BY:
SURVEY DATE:

SHEET NAME:
EROSION CONTROL NOTES
SHEET NO:
10

P:\24-010 - 2400 Railroad Avenue Water Main Extension\24-010-001 Engineering\Drawings\Sheet\Overview.dwg 2/10/2023 8:18am
 6505811.dwg (User: 1/25/2023)

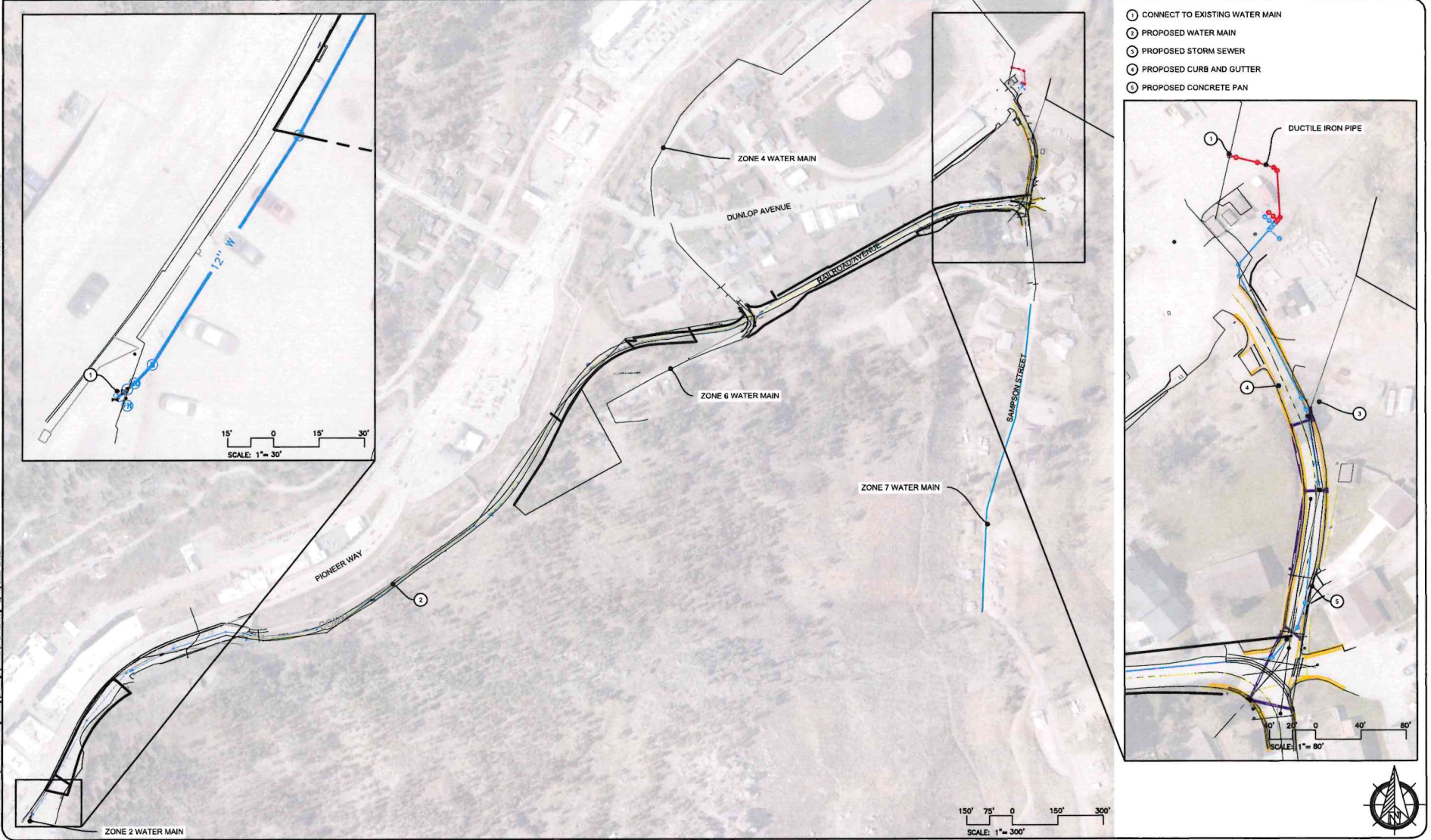

- ① CONNECT TO EXISTING WATER MAIN
- ② PROPOSED WATER MAIN
- ③ PROPOSED STORM SEWER
- ④ PROPOSED CURB AND GUTTER
- ⑤ PROPOSED CONCRETE PAN

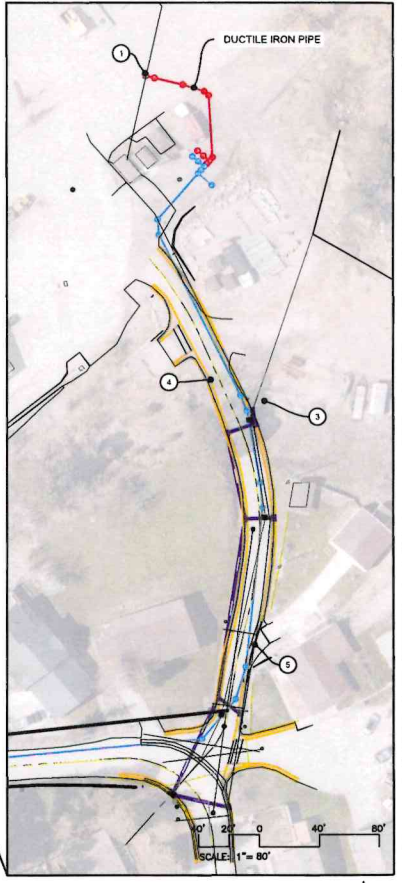

Towey Design Group, Inc.
 147 Chisholm Drive
 Box Elder, SD 57719
 605.600.3758

LOGO:



DEADWOOD RAILROAD AVENUE
WATER MAIN EXTENSION
DEADWOOD, SOUTH DAKOTA

REVISIONS:
35% DESIGN PLANS
95% DESIGN PLANS

JOB NUMBER: 24-010
 DESIGNED BY: BK
 DRAWN BY: BK/NR
 SURVEYED BY:
 SURVEY DATE:

SHEET NAME:
OVERVIEW
 SHEET NO:
 11

56.0457 N.W. 1/4 Sec. 105, T150N, R18E

PROJECT: 24-010 - 100' Railroad Avenue Water Main Extension (Station 0+00 to 26+76.76) | DRAWN BY: BK/NR | DATE: 2/12/2025 | EDITION: 01

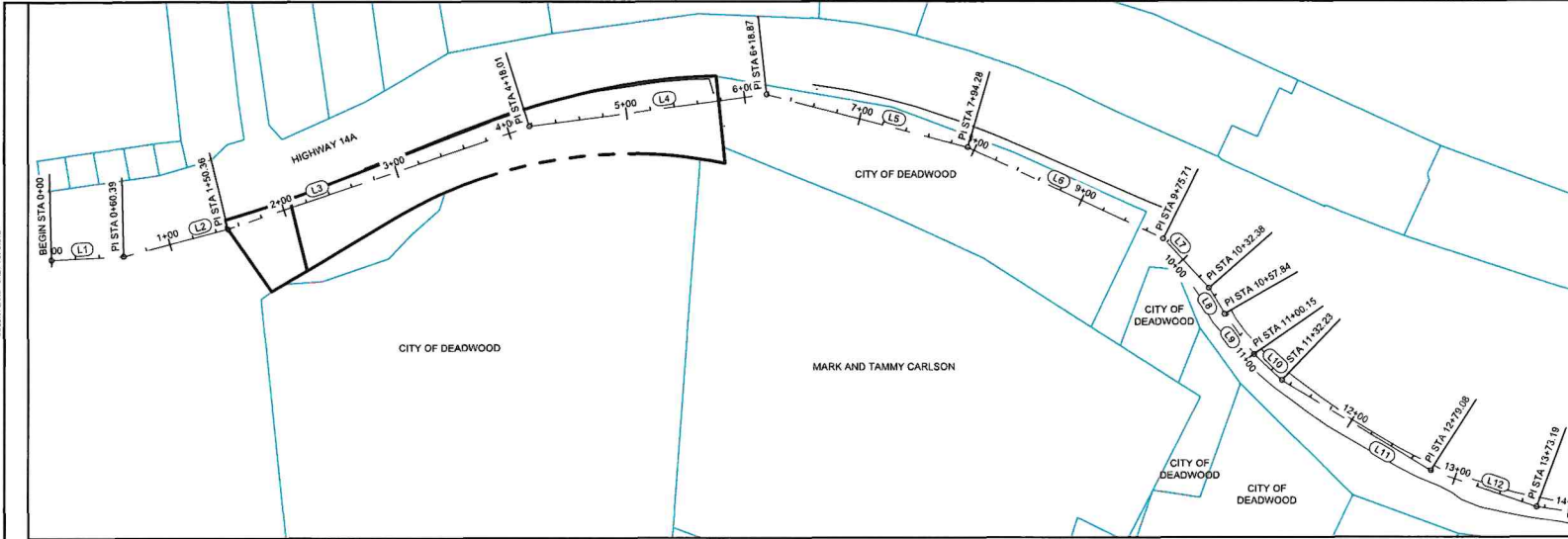

MATCHLINE A (THIS SHEET)

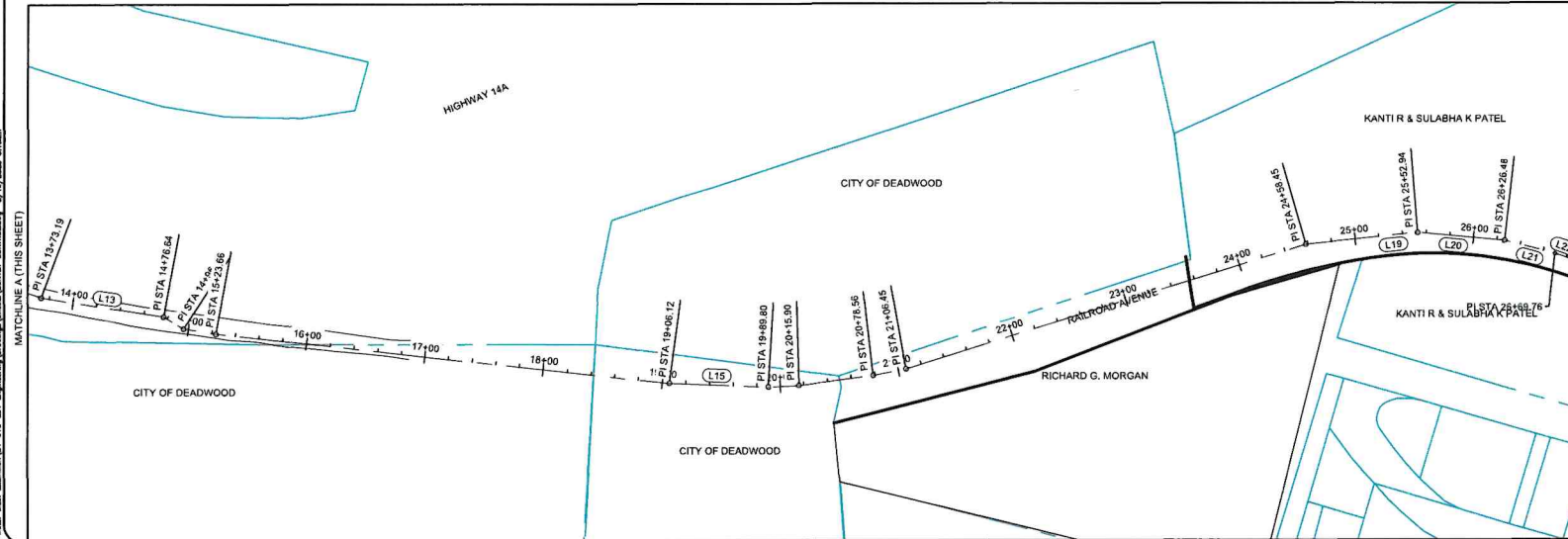

MATCHLINE B (SHEET 13)

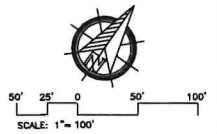

Towey Design Group, Inc.
147 Chisholm Drive
Box Elder, SD 57719
605.600.3758

LOGO

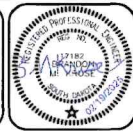

DEADWOOD RAILROAD AVENUE
WATER MAIN EXTENSION
DEADWOOD, SOUTH DAKOTA

REVISIONS:
35% DESIGN PLANS
95% DESIGN PLANS

JOB NUMBER: 24-010
DESIGNED BY: BK
DRAWN BY: BK/NR
SURVEYED BY:
SURVEY DATE:

SHEET NAME:
SURVEY CONTROL PLAN

SHEET NO:
12

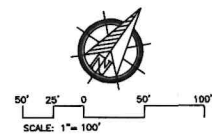
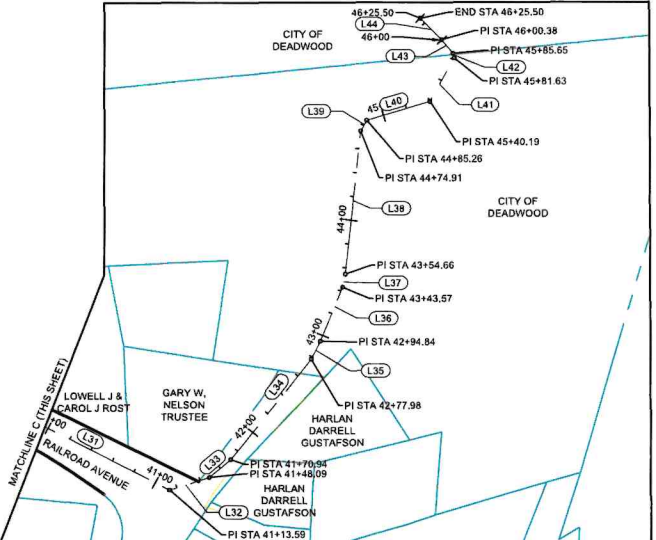
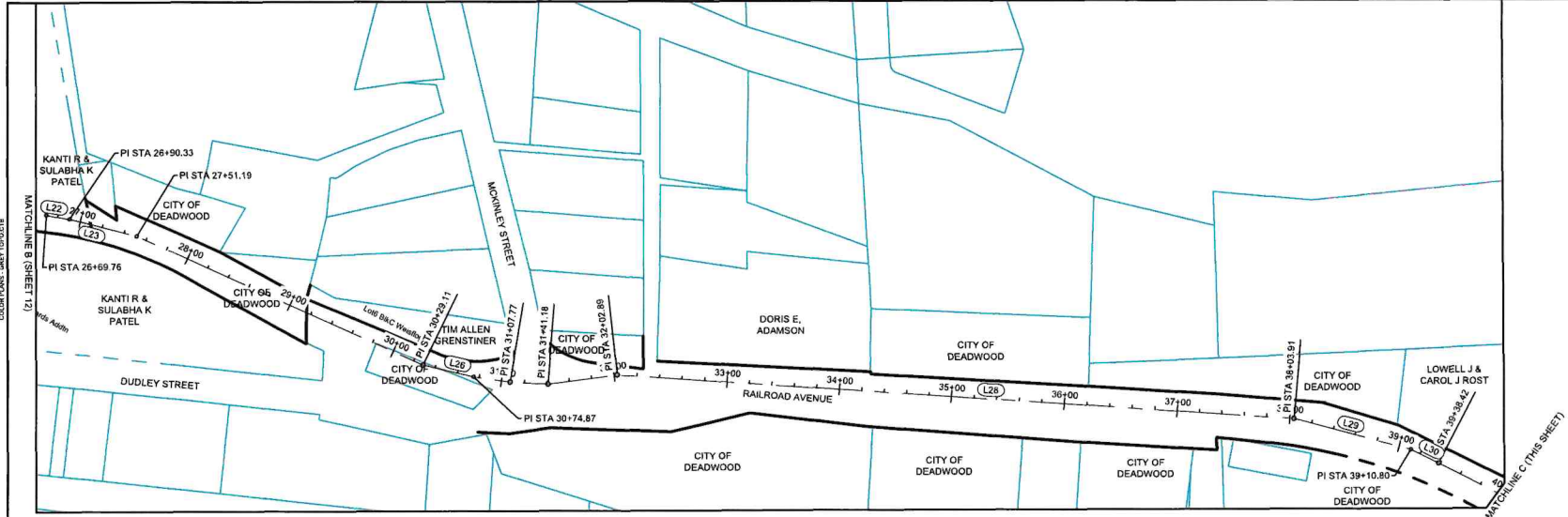

C:\p1\100\100.dwg 1/10/2018 11:14am

P:\10-100 - 100 Railroad Avenue - 100.dwg 1/10/2018 11:14am 2/10/2018 11:14am



Towey Design Group, Inc.
147 Chisholm Drive
Box Elder, SD 57719
605.600.3758

LOGO:



DEADWOOD RAILROAD AVENUE
WATER MAIN EXTENSION
DEADWOOD, SOUTH DAKOTA

REVISIONS:
35% DESIGN PLANS
95% DESIGN PLANS

JOB NUMBER: 24-010
DESIGNED BY: BK
DRAWN BY: BK/NR
SURVEYED BY:
SURVEY DATE:

SHEET NAME:
SURVEY CONTROL PLAN
SHEET NO:
13

SCALE: HORIZONTAL: 1"=40.00'

P:\14-010 - RRD - Railroad Avenue Water Main Extension\14-010-001 - Explanation\Drawings\Sheet\01400001.dwg 2/17/2016 8:18am

ALIGNMENT - WATERMAIN - ALIGNMENT

NUMBER	START STATION	NORTHING	EASTING	LENGTH	END STATION	END NORTHING	END EASTING	BEARING
L1	0+00.00	220700.16	993874.29	60.39	0+60.39	220743.15	993916.70	N44° 36' 53.67"E
L2	0+60.39	220743.15	993916.70	89.96	1+50.36	220819.10	9939964.95	N32° 25' 40.01"E
L3	1+50.36	220819.10	9939964.95	267.65	4+18.01	221054.47	994092.36	N28° 25' 40.01"E
L4	4+18.01	221054.47	994092.36	200.86	6+18.87	221209.06	994220.60	N39° 40' 40.01"E
L5	6+18.87	221209.06	994220.60	175.41	7+94.28	221290.93	994375.74	N62° 10' 40.01"E
L6	7+94.28	221290.93	994375.74	181.43	9+75.71	221345.41	994548.79	N72° 31' 32.00"E
L7	9+75.71	221345.41	994548.79	56.67	10+32.38	221340.44	994605.25	S84° 58' 28.00"E
L8	10+32.38	221340.44	994605.25	25.46	10+57.84	221333.31	994629.69	S73° 43' 28.00"E
L9	10+57.84	221333.31	994629.69	42.32	11+00.15	221325.04	994671.18	S78° 43' 28.00"E
L10	11+00.15	221325.04	994671.18	32.08	11+32.23	221325.02	994703.26	S89° 58' 28.00"E
L11	11+32.23	221325.02	994703.26	146.85	12+79.08	221353.66	994847.29	N78° 45' 15.49"E
L12	12+79.08	221353.66	994847.29	94.11	13+73.19	221391.23	994933.58	N68° 28' 21.28"E
L13	13+73.19	221391.23	994933.58	103.44	14+76.64	221446.50	995019.72	N56° 23' 07.27"E
L15	19+06.32	221694.29	995369.73	83.68	19+89.80	221748.64	995433.36	N49° 29' 55.44"E
L19	24+58.45	222142.94	995684.03	94.50	25+52.94	222213.95	995746.37	N41° 16' 40.99"E
L20	25+52.94	222213.95	995746.37	73.54	26+26.48	222258.69	995804.74	N52° 31' 40.99"E
L21	26+26.48	222258.69	995804.74	43.28	26+69.76	222278.89	995843.02	N62° 11' 14.61"E
L22	26+69.76	222278.89	995843.02	20.57	26+90.33	222286.66	995861.98	N67° 11' 14.61"E
L23	26+90.33	222286.66	995861.98	60.86	27+51.19	222305.48	995919.92	N72° 11' 14.61"E
L26	30+29.11	222344.28	996195.11	45.77	30+74.87	222359.39	996238.32	N70° 43' 27.44"E
L28	32+02.89	222428.87	996344.76	601.02	38+03.91	222717.42	996871.98	N61° 18' 26.73"E
L29	38+03.91	222717.42	996871.98	106.89	39+10.80	222749.47	996973.96	N72° 33' 26.73"E
L30	39+10.80	222749.47	996973.96	27.61	39+38.42	222752.44	997001.41	N83° 46' 26.73"E
L31	39+38.42	222752.44	997001.41	175.17	41+13.59	222768.61	997175.83	N84° 42' 14.89"E
L32	41+13.59	222768.61	997175.83	34.50	41+48.09	222795.16	997197.87	N39° 42' 14.89"E
L33	41+48.09	222795.16	997197.87	22.85	41+70.94	222816.99	997204.63	N17° 12' 14.89"E
L34	41+70.94	222816.99	997204.63	107.04	42+77.98	222923.45	997215.73	N05° 57' 14.89"E
L35	42+77.98	222923.45	997215.73	16.86	42+94.84	222940.24	997214.18	N05° 17' 45.31"W
L36	42+94.84	222940.24	997214.18	48.73	43+43.57	222988.18	997205.47	N10° 17' 45.31"W
L37	43+43.57	222988.18	997205.47	11.08	43+54.66	222998.49	997201.40	N21° 32' 45.31"W
L38	43+54.66	222998.49	997201.40	120.25	44+74.91	223106.07	997147.65	N26° 32' 45.31"W
L39	44+74.91	223106.07	997147.65	10.36	44+85.26	223116.40	997147.03	N03° 28' 30.22"W
L40	44+85.26	223116.40	997147.03	54.92	45+40.19	223157.93	997182.97	N40° 52' 40.68"E
L41	45+40.19	223157.93	997182.97	41.44	45+81.63	223199.30	997180.46	N03° 28' 30.22"W
L42	45+81.63	223199.30	997180.46	4.02	45+85.65	223201.86	997177.45	N48° 28' 30.22"W
L43	45+85.65	223201.86	997177.45	14.74	46+00.38	223206.38	997163.39	N72° 34' 37.34"W
L44	46+00.38	223206.38	997163.39	25.12	46+25.50	223212.24	997138.97	N78° 29' 31.31"W



Towey Design Group, Inc.
147 Chisholm Drive
Box Elder, SD 57719
605.600.3758

LOGO:



DEADWOOD RAILROAD AVENUE
WATER MAIN EXTENSION
DEADWOOD, SOUTH DAKOTA

REVISIONS:

35% DESIGN PLANS
95% DESIGN PLANS

JOB NUMBER: 24-010

DESIGNED BY: BK
DRAWN BY: BK/NR
SURVEYED BY:
SURVEY DATE:

SHEET NAME:

SURVEY CONTROL TABLE

SHEET NO:

14

PROJECT: 24-010 - 3RD Water Main Extension (Sheet) 24-010-001 Engineering: [Signature] Date: 2/19/2025 8:15am
 DRAWN BY: BK/KNR
 CHECKED BY: [Signature]
 SCALE: 1" = 40'
 SHEET NO: 15

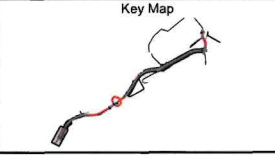
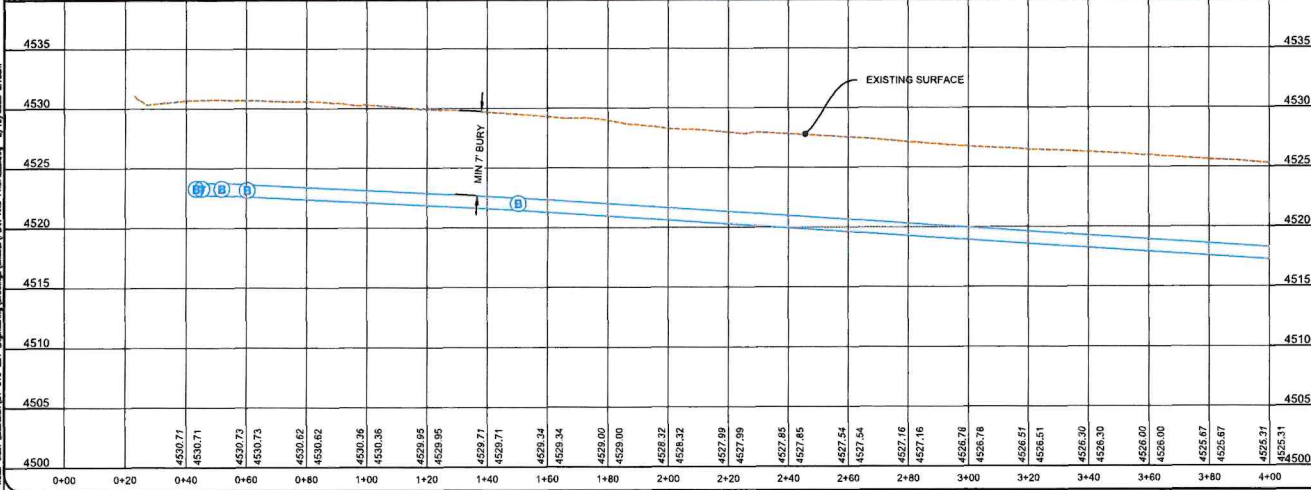
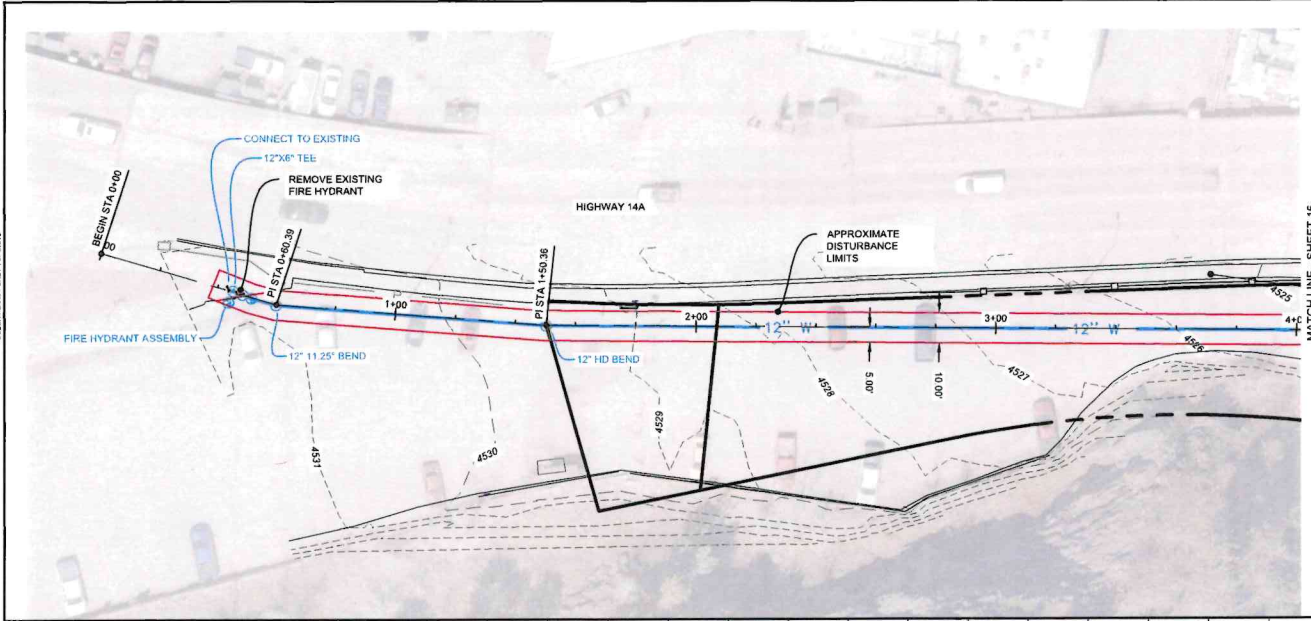

NOTE:
 CONTRACTOR TO SAW CUT AND REMOVE ASPHALT NECESSARY TO INSTALL WATER MAIN.
 CONTRACTOR TO REPLACE TOP SURFACING AS A 1 TO 1 EQUAL.
 CONTRACTOR TO FIELD VERIFY LOCATION OF CONNECTION POINT BEFORE CONSTRUCTION.
 CONNECTION SHALL BE MADE TO THE EXISTING 12" WATERMAIN.

STATION	OFF-SET	T.O.P. ELEV	ITEM DESC
0+43.41	0.54'L		CONNECT TO EXISTING
0+45.35	0.46'L	4523.78	12"x6" TEE
0+51.93	0.14'F	4523.78	12" HD BEND
0+65.39	0.00'	4523.68	12" 11.25" BEND
1+50.38	0.00'	4522.50	12" HD BEND

DESCRIPTION	FG ELEV = 4530.78'
FIRE HYDRANT ASSEMBLY STA 0+44.98 - 3.63' R	INV ELEV = 4522.78'
	BURY DEPTH = 8.00'

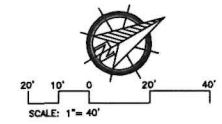
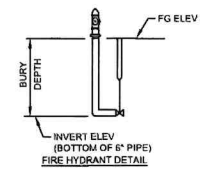

Towey Design Group, Inc.
 147 Chisholm Drive
 Box Elder, SD 57719
 605.600.3758



DEADWOOD RAILROAD AVENUE
WATER MAIN EXTENSION
DEADWOOD, SOUTH DAKOTA

REVISIONS:
35% DESIGN PLANS
95% DESIGN PLANS

JOB NUMBER: 24-010
DESIGNED BY: BK
DRAWN BY: BK/KNR
SURVEYED BY:
SURVEY DATE:

SHEET NAME: WATER MAIN PLAN AND PROFILE - 0+00 - 4+00
SHEET NO: 15

CONTRACTOR TO SAW CUT AND REMOVE ASPHALT NECESSARY TO INSTALL WATER MAIN

CONTRACTOR TO REPLACE TOP SURFACING AS A 1 TO 1 EQUAL.

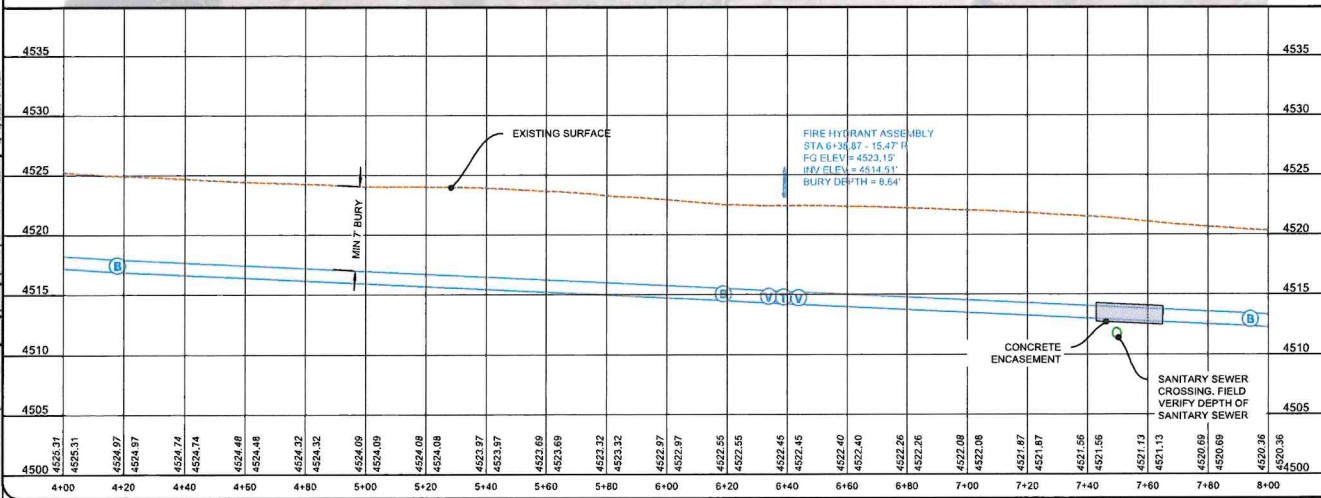
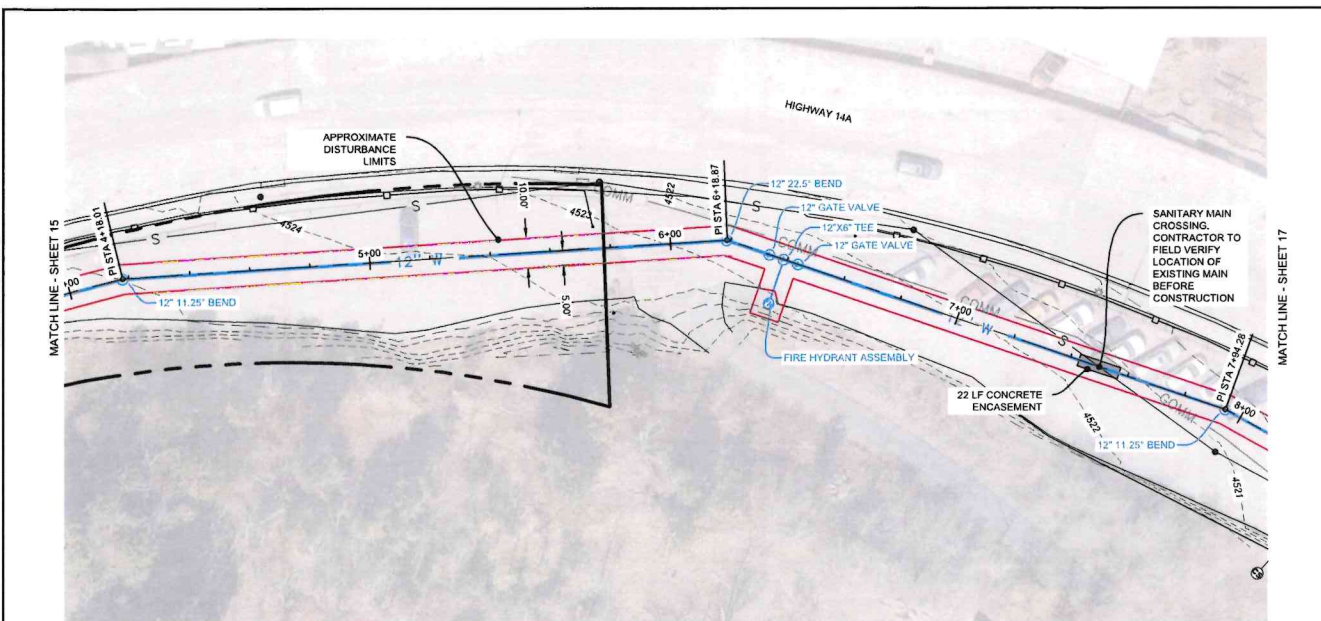

TDG
 Towey Design Group, Inc.
 147 Chisholm Drive
 Box Elder, SD 57719
 605.600.3758

LOGO:

DEADWOOD RAILROAD AVENUE
WATER MAIN EXTENSION
DEADWOOD, SOUTH DAKOTA

REVISIONS:
 35% DESIGN PLANS
 95% DESIGN PLANS

JOB NUMBER: 24-010
 DESIGNED BY: BK
 DRAWN BY: BK/NR
 SURVEYED BY:
 SURVEY DATE:

SHEET NAME:
WATER MAIN PLAN AND PROFILE - 4+00 - 8+00
 SHEET NO: 16

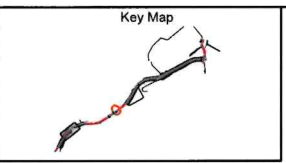

NOTE:
 CONTRACTOR TO SAW CUT AND REMOVE ASPHALT NECESSARY TO INSTALL WATER MAIN
 CONTRACTOR TO REPLACE TOP SURFACING AS A 1 TO 1 EQUAL.

WATER MAIN NOTES			
STATION	OFFSET	T.O.P. ELEV.	ITEM DESC.
4+18.01	0.00'	4517.97	12" 11.25' BEND
6+18.87	0.00'	4515.53	12" 22.5' BEND
6+33.87	0.00'	4515.32	12" GATE VALVE
6+38.87	0.00'	4515.26	12"x6" TEE
6+43.87	0.00'	4515.20	12" GATE VALVE
7+94.28	0.00'	4513.41	12" 11.25' BEND

INSTALL YARD HYDRANT	
DESCRIPTION	
FIRE HYDRANT ASSEMBLY STA 6+38.87 - 15.47' R	FG ELEV = 4523.15' INV ELEV = 4514.51' BURY DEPTH = 8.64'

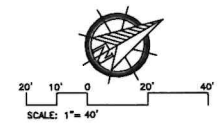
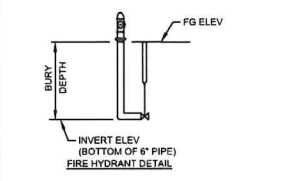

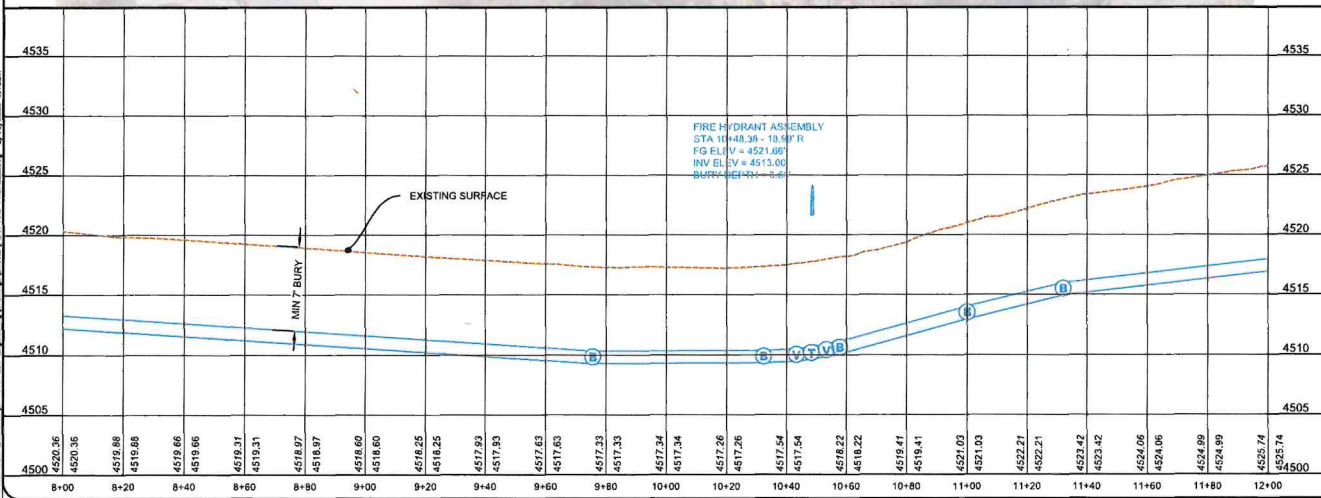
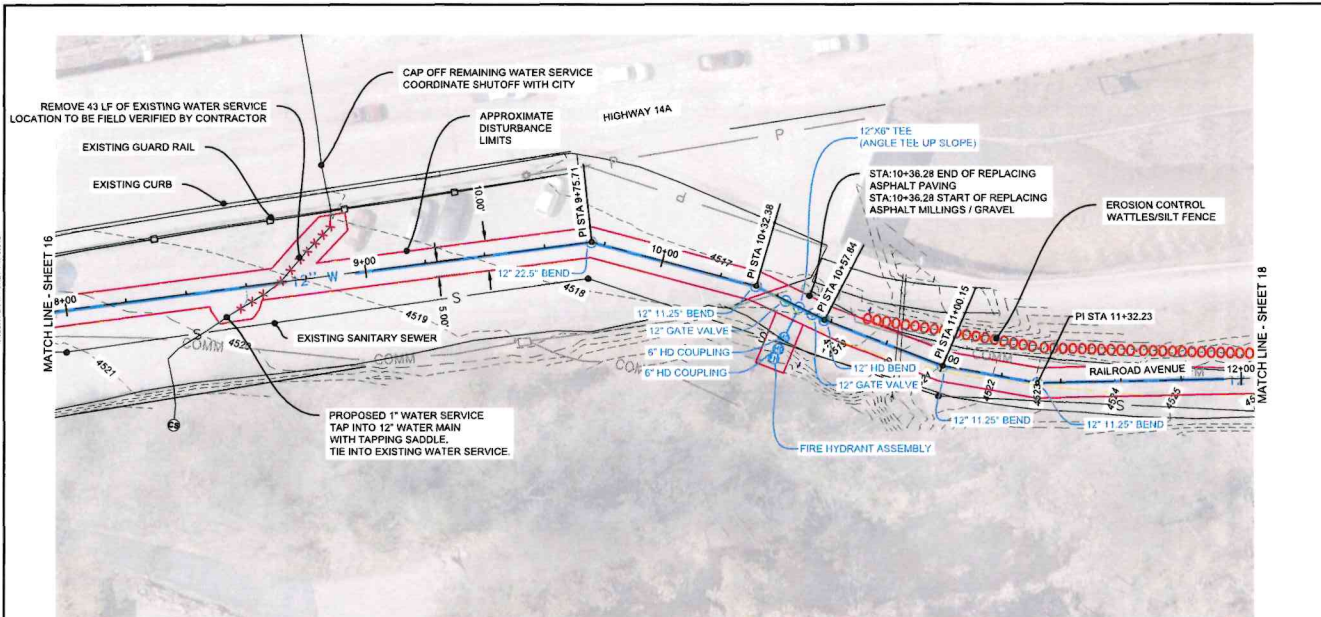

TDG
 Towey Design Group, Inc.
 147 Chisholm Drive
 Box Elder, SD 57719
 605.600.3758

LOGO

DEADWOOD RAILROAD AVENUE
WATER MAIN EXTENSION
DEADWOOD, SOUTH DAKOTA

REVISIONS:
 35% DESIGN PLANS
 95% DESIGN PLANS

JOB NUMBER: 24-010
 DESIGNED BY: BK
 DRAWN BY: BK/NR
 SURVEYED BY:
 SURVEY DATE:

SHEET NAME:
WATER MAIN PLAN AND PROFILE - 8+00 - 12+00
 SHEET NO: **17**

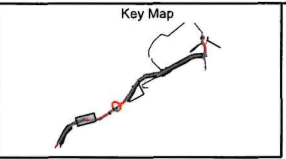

NOTE:
 CONTRACTOR TO SAW CUT AND REMOVE ASPHALT NECESSARY TO INSTALL WATER MAIN
 CONTRACTOR TO REPLACE TOP SURFACING AS A 1 TO 1 EQUAL.

WATER MAIN NOTES			
STATION	OFFSET	T.O.P. ELEV	ITEM DESC.
8+75.71	0.00'	4510.33	12" 22.5' BEND
10+32.38	0.00'	4510.37	12" 11.25' BEND
10+43.38	0.00'	4510.50	12" GATE VALVE
10+48.38	0.00'	4510.50	12" GATE VALVE
10+53.38	0.00'	4510.50	12" GATE VALVE
10+57.84	0.00'	4510.50	12" HD BEND
11+00.15	0.00'	4514.02	12" 11.25' BEND

INSTALL YARD HYDRANT	
DESCRIPTION	
FIRE HYDRANT ASSEMBLY STA 10+48.38 - 18.99' R	FG ELEV = 4521.66' INV ELEV = 4513.00' BURY DEPTH = 8.66'

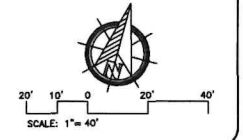
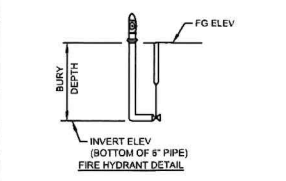

5/19/2025 8:11 AM

PROJECT: 24-010 - RWD Railroad Avenue Water Main Extension (12+00-16+00) - 5/19/2025 8:11 AM

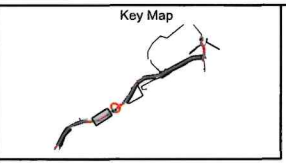
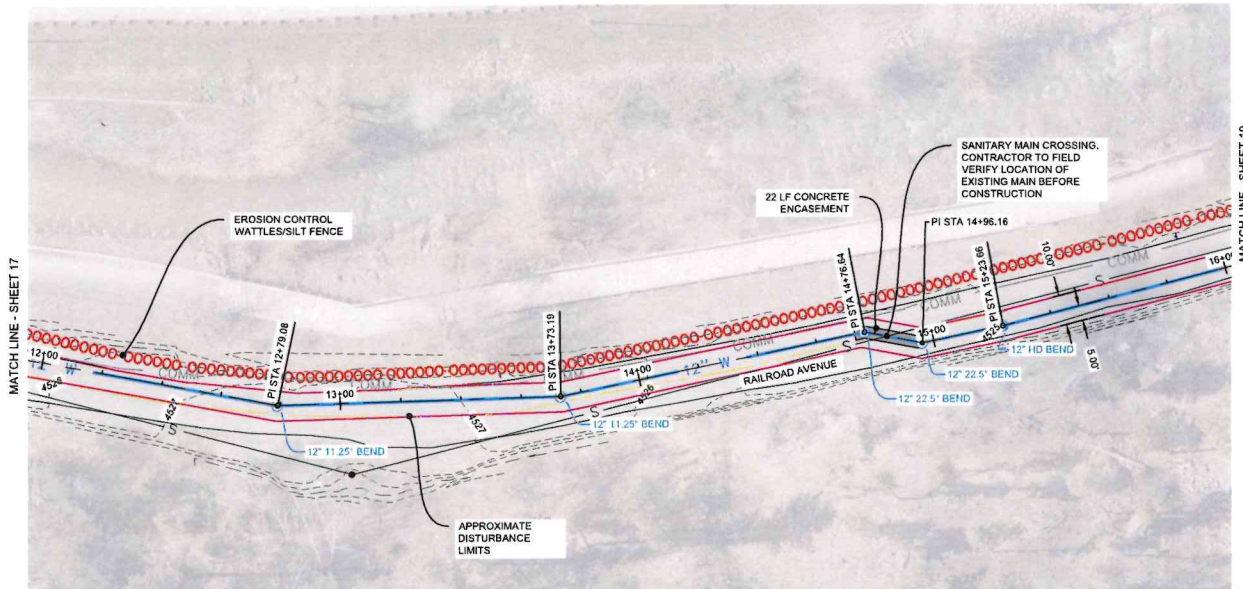

NOTE:
 CONTRACTOR TO SAW CUT AND REMOVE ASPHALT NECESSARY TO INSTALL WATER MAIN
 CONTRACTOR TO REPLACE TOP SURFACING AS A 1 TO 1 EQUAL.

WATER MAIN NOTES			
STATION	OFFSET	T.O.P. ELEV	ITEM DESC
12+79.06	0.00'	4520.22	12" 11.25' BEND
13+73.19	0.00'	4519.38	12" 11.25' BEND
14+76.64	0.00'	4518.27	12" 22.5' BEND
14+96.16	0.00'	4518.20	12" 22.5' BEND
15+23.65	0.00'	4518.05	12" HD BEND

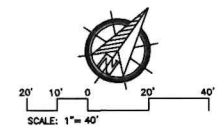
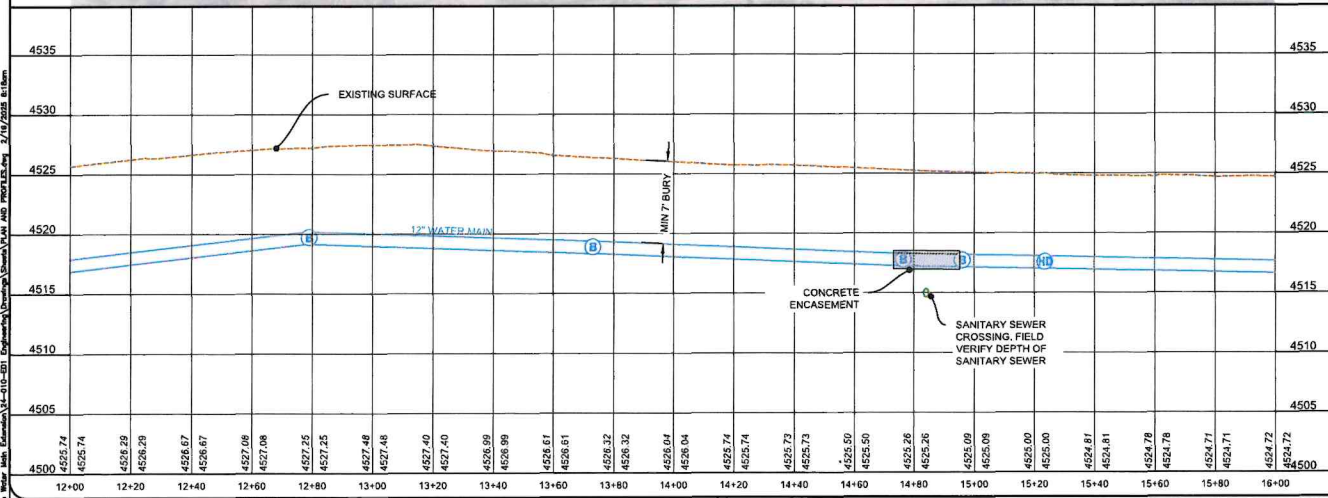

Towey Design Group, Inc.
 147 Chisholm Drive
 Box Elder, SD 57719
 605.600.3758

LOGO:



DEADWOOD RAILROAD AVENUE
WATER MAIN EXTENSION
DEADWOOD, SOUTH DAKOTA

REVISIONS:

35% DESIGN PLANS
95% DESIGN PLANS

JOB NUMBER: 24-010

DESIGNED BY: BK
DRAWN BY: BK/NR
SURVEYED BY:
SURVEY DATE:

SHEET NAME:
WATER MAIN PLAN AND PROFILE - 12+00 - 16+00

SHEET NO:
18

CONTRACT NO. 24-010-001

PROJECT NO. 24-010-001

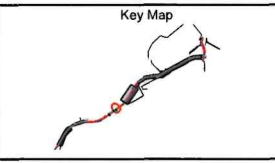
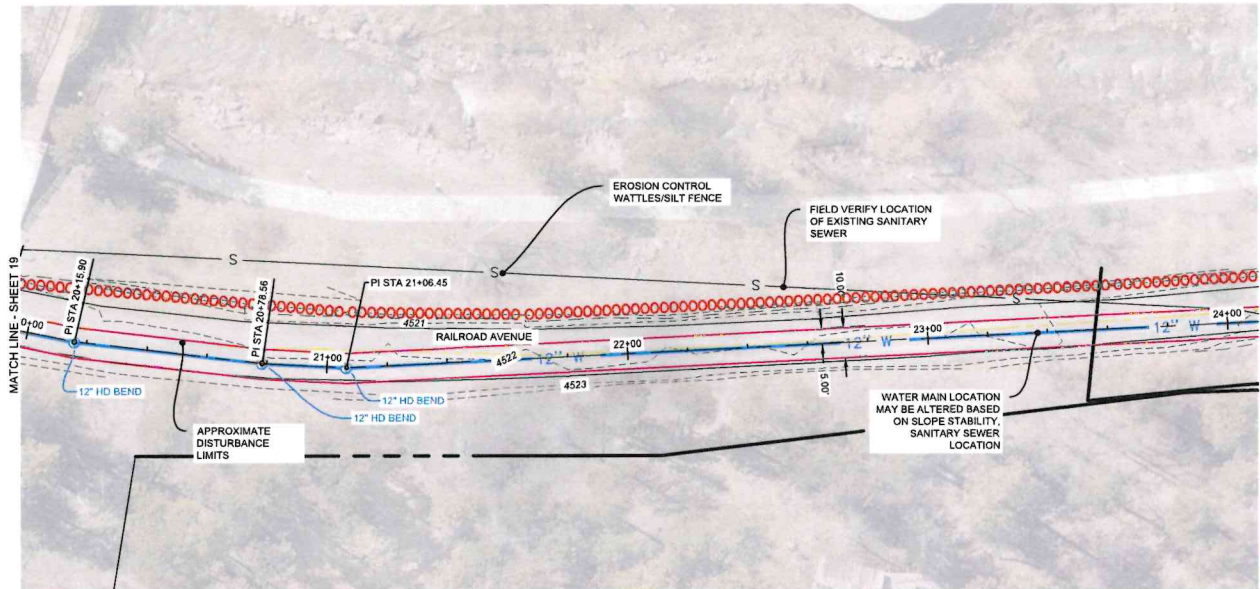

NOTE:
 CONTRACTOR TO SAW CUT AND REMOVE ASPHALT NECESSARY TO INSTALL WATER MAIN
 CONTRACTOR TO REPLACE TOP SURFACING AS A 1 TO 1 EQUAL.

WATER MAIN NOTES			
STATION	OFFSET	T.O.P. ELEV.	ITEM DESC.
20+15.90	0.00'	4515.54	12" HD BEND
20+78.56	0.00'	4514.56	12" HD BEND
21+05.45	0.00'	4514.51	12" HD BEND

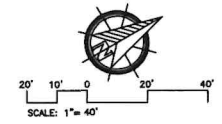
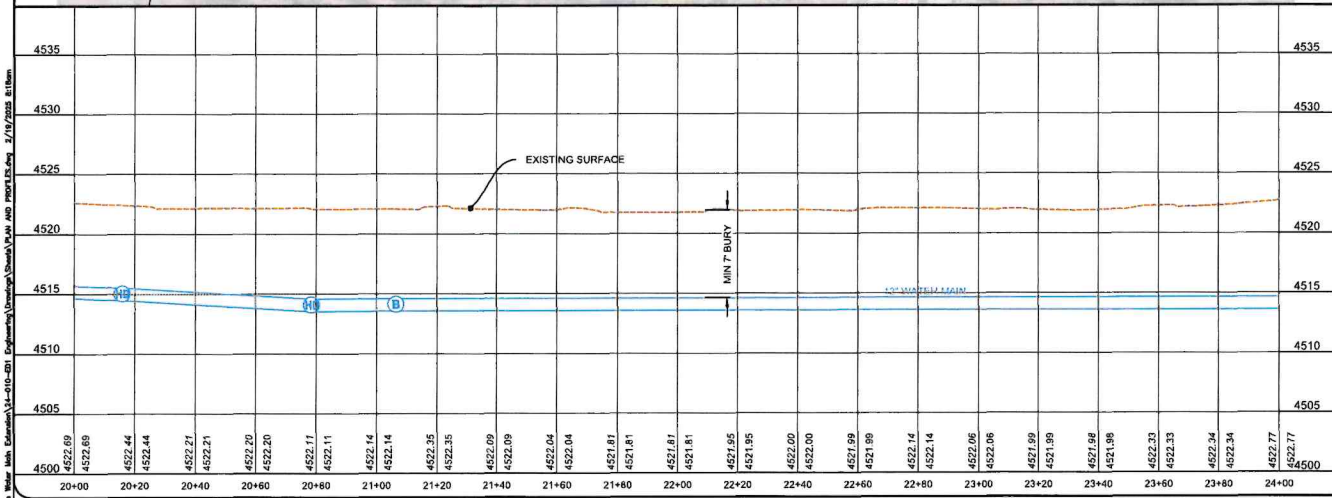

Towey Design Group, Inc.
 147 Chisholm Drive
 Box Elder, SD 57719
 605.600.3758

LOGO:



DEADWOOD RAILROAD AVENUE
WATER MAIN EXTENSION
DEADWOOD, SOUTH DAKOTA

REVISIONS:

35% DESIGN PLANS
95% DESIGN PLANS

JOB NUMBER: 24-010

DESIGNED BY: BK
DRAWN BY: BK/NR
SURVEYED BY:
SURVEY DATE:

SHEET NAME:
WATER MAIN PLAN AND PROFILE - 20+00 - 24+00

SHEET NO:
20

CONTRACT NUMBER: 24-010

PROJECT NUMBER: 24-010-001

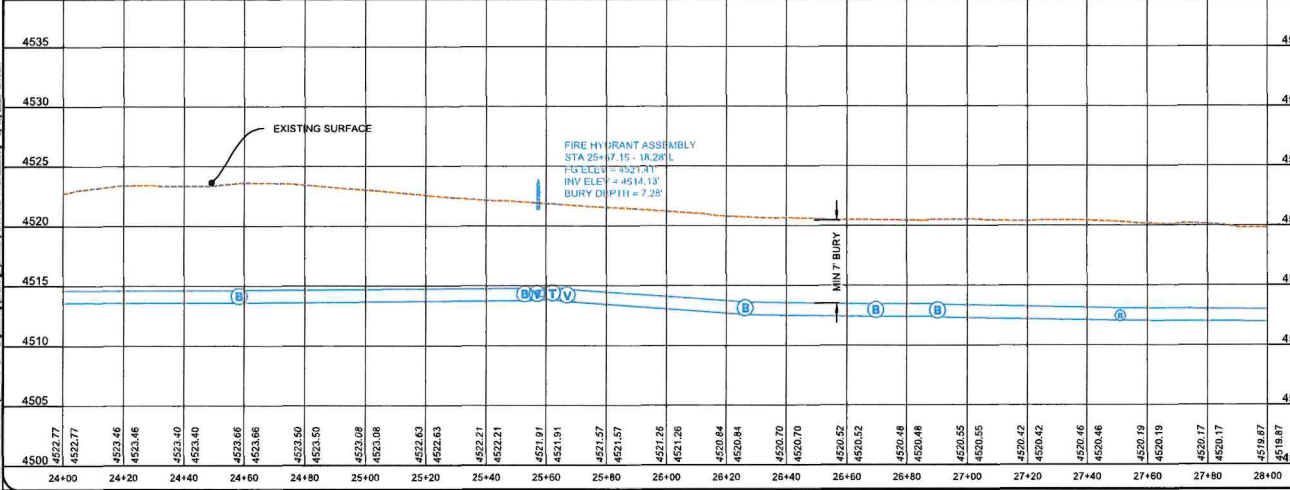
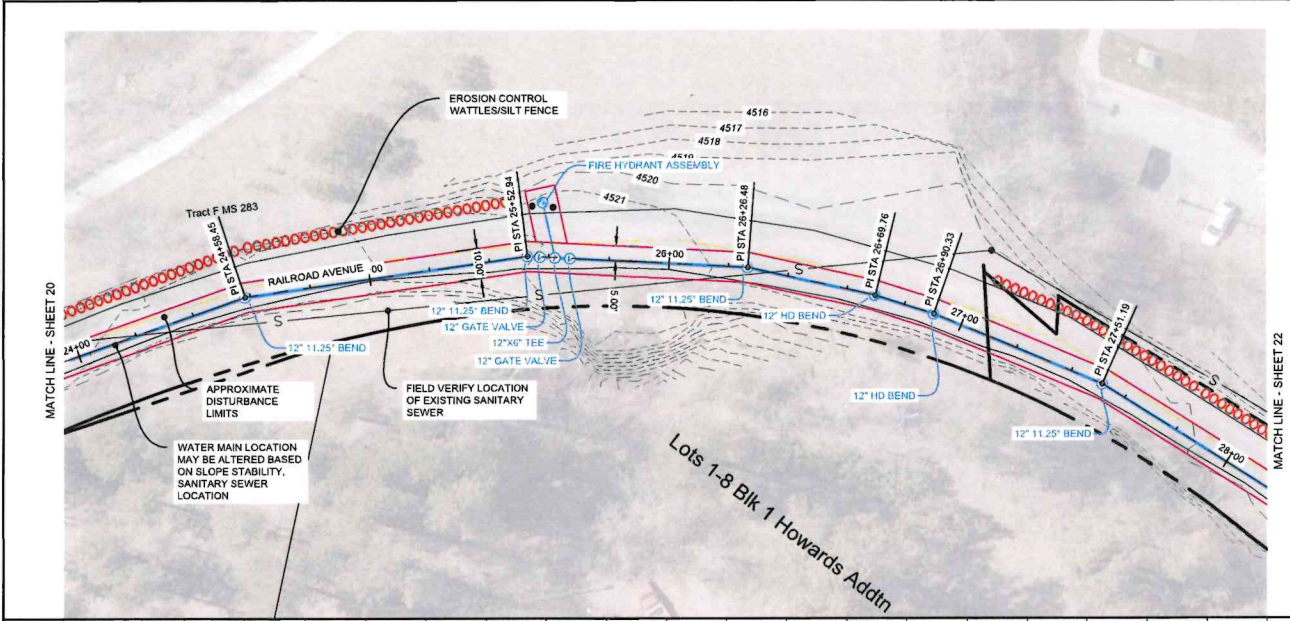

TDG
 Towey Design Group, Inc.
 147 Chisholm Drive
 Box Elder, SD 57719
 605.600.3758

LOGO:

DEADWOOD RAILROAD AVENUE
WATER MAIN EXTENSION
DEADWOOD, SOUTH DAKOTA

REVISIONS:

35% DESIGN PLANS
95% DESIGN PLANS

JOB NUMBER: 24-010

DESIGNED BY: BK
DRAWN BY: BK/NR
SURVEYED BY:
SURVEY DATE:

SHEET NAME:
WATER MAIN PLAN AND PROFILE - 24+00 - 28+00

SHEET NO: **21**

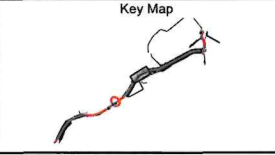

NOTE:
 CONTRACTOR TO SAW CUT AND REMOVE ASPHALT NECESSARY TO INSTALL WATER MAIN
 CONTRACTOR TO REPLACE TOP SURFACING AS A 1 TO 1 EQUAL.

WATER MAIN NOTES

STATION	OFFSET	F.O.P. ELEV	ITEM DESC
24+58.45	0.00'	4514.64	12" 11.25' BEND
25+52.94	0.00'	4514.80	12" 11.25' BEND
25+57.15	0.00'	4514.53	12" GATE VALVE
25+62.15	0.00'	4514.96	12"x6" TEE
25+67.15	0.00'	4514.70	12" GATE VALVE
26+26.48	0.00'	4513.61	12" 11.25' BEND
26+69.75	0.00'	4513.44	12" HD BEND
26+90.33	0.00'	4513.44	12" HD BEND
27+51.19	0.00'	4513.09	12" 11.25' BEND

INSTALL YARD HYDRANT

DESCRIPTION	FG ELEV
FIRE HYDRANT ASSEMBLY STA 25+57.15 - 18.28' L	FG ELEV = 4521.41' INV ELEV = 4514.13' BURY DEPTH = 7.28'

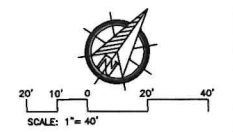
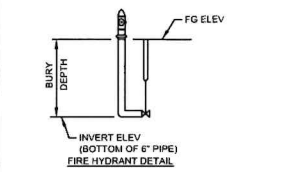

GROUND PLAN SEE SHEET 20/20/21

PLAN - 24-010 - 100 Deadwood Avenue, Miller, SD 57030-0101, E:\Projects\24-010\DWG\24-010-021.dwg, 2/10/2024, 8:18am

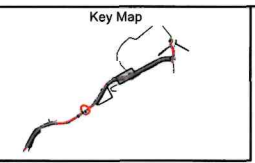
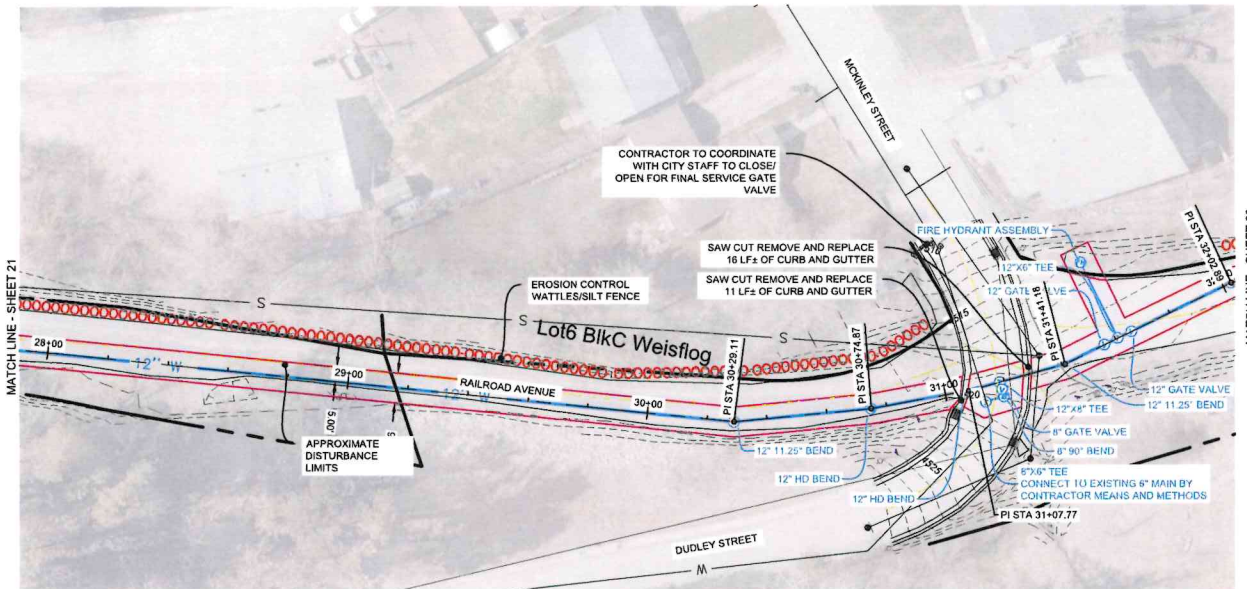

NOTE:
CONTRACTOR TO SAW CUT AND REMOVE ASPHALT NECESSARY TO INSTALL WATER MAIN
CONTRACTOR TO REPLACE TOP SURFACING AS A 1 TO 1 EQUAL.

WATER MAIN NOTES			
STATION	OFFSET	T.O.P. ELEV	ITEM DESC
30+29.11	0.00'	4512.67	12" 11.25' BEND
30+74.87	0.00'	4511.09	12" HD BEND
31+07.77	0.00'	4511.07	12" HD BEND
31+12.53	5.13'R	4510.89	6"X6" TEE CONNECT TO EXISTING 6" MAIN BY CONTRACTOR MEANS AND METHODS
31+16.72	0.00'	4511.05	12"X6" TEE
31+18.75	5.00'R	4510.89	8" 90° BEND
31+18.77	2.50'R	4510.89	8" GATE VALVE
31+41.18	0.00'	4511.03	12" 11.25' BEND
31+56.01	0.00'	4511.00	12" GATE VALVE
31+61.01	0.00'	4511.00	12"X6" TEE
31+60.01	0.00'	4510.99	12" GATE VALVE

INSTALL YARD HYDRANT	
DESCRIPTION	
FIRE HYDRANT ASSEMBLY STA 31+61.01 - 28.18' L	FG ELEV = 4516.33' INV ELEV = 4510.25' BURY DEPTH = 6.08'

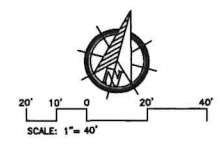
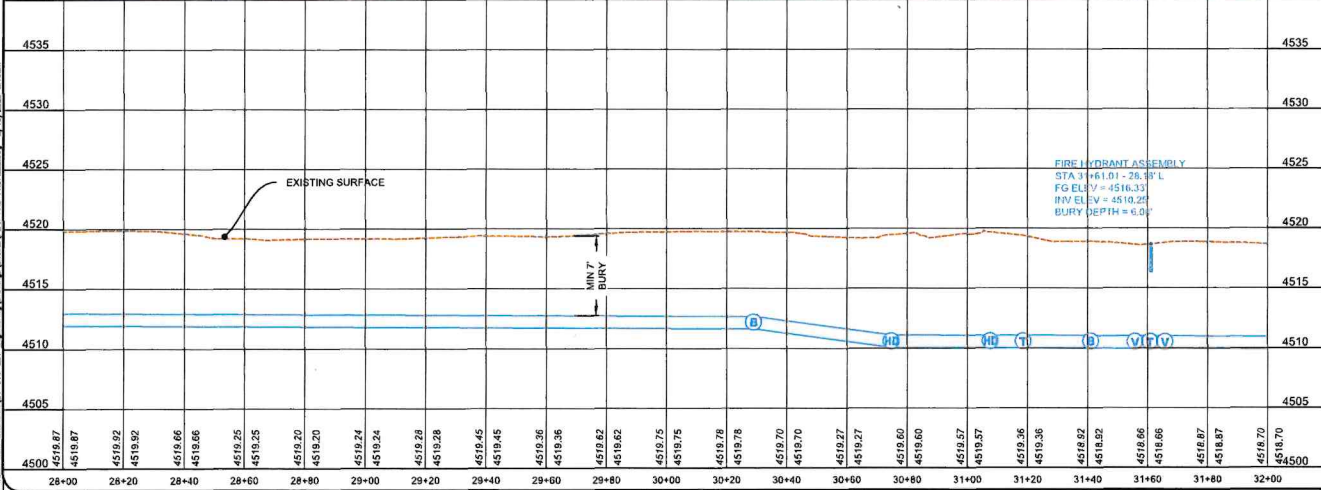
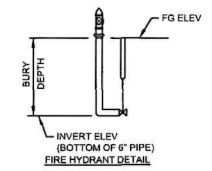

TDG
Towey Design Group, Inc.
147 Chisholm Drive
Box Elder, SD 57719
605.600.3758

LOGO:

**DEADWOOD RAILROAD AVENUE
WATER MAIN EXTENSION
DEADWOOD, SOUTH DAKOTA**

REVISIONS:

35% DESIGN PLANS
95% DESIGN PLANS

JOB NUMBER: 24-010

DESIGNED BY: BK
DRAWN BY: BK/NR
SURVEYED BY:
SURVEY DATE:

SHEET NAME:
**WATER MAIN PLAN AND
PROFILE - 28+00 - 32+00**

SHEET NO: **22**

CONTRACT NAME: 24-010-010

PROJECT NO: 24-010-010

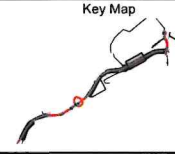
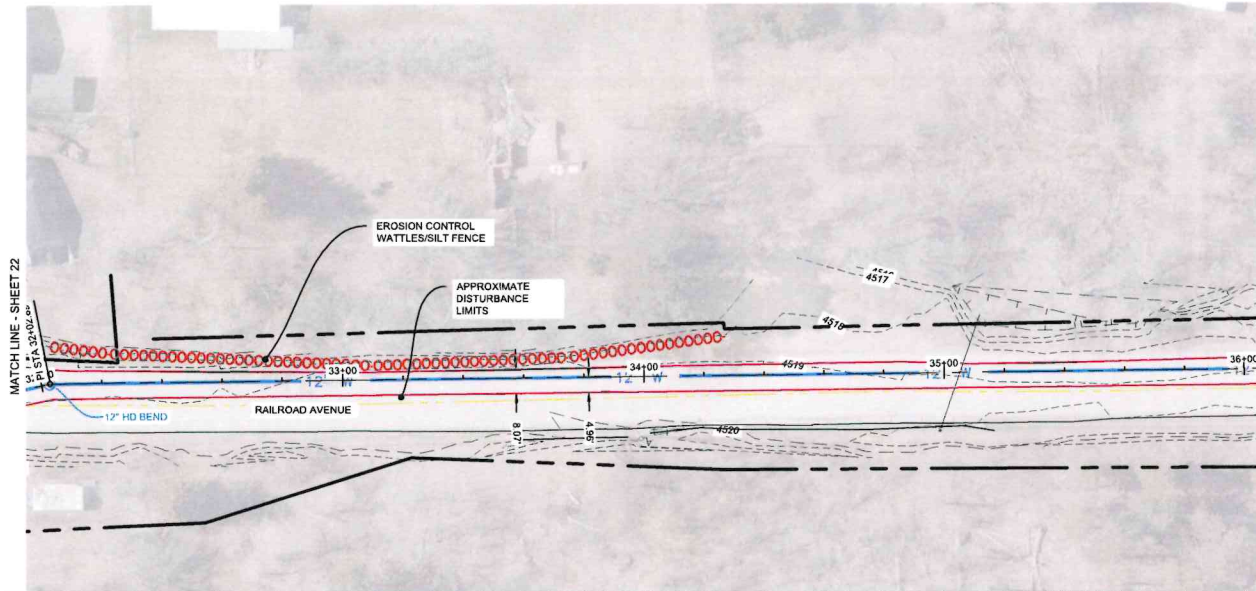

NOTE:
CONTRACTOR TO SAW CUT AND REMOVE ASPHALT NECESSARY TO INSTALL WATER MAIN
CONTRACTOR TO REPLACE TOP SURFACING AS A 1 TO 1 EQUAL.

WATER MAIN NOTES			
STATION	OFFSET	T.O.P. ELEV	ITEM DESC
32+02.88	0.00'	4516.83	12" HD BEND

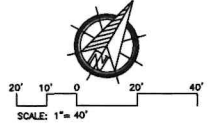
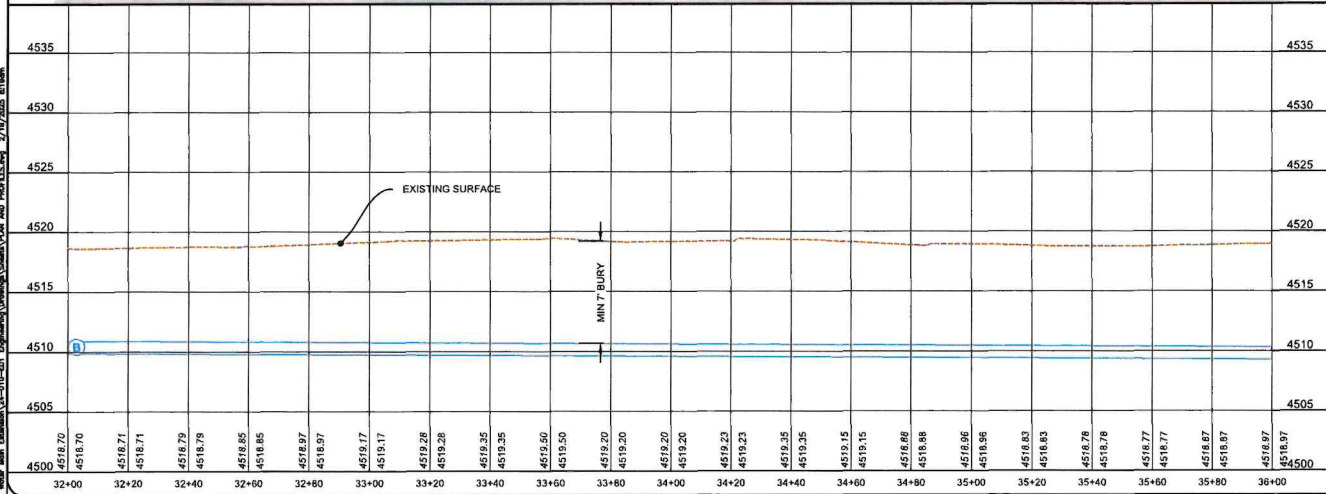

Towey Design Group, Inc.
147 Chisholm Drive
Box Elder, SD 57719
605.600.3758

LOGO:



DEADWOOD RAILROAD AVENUE
WATER MAIN EXTENSION
DEADWOOD, SOUTH DAKOTA

REVISIONS:
35% DESIGN PLANS
95% DESIGN PLANS

JOB NUMBER: 24-010
DESIGNED BY: BK
DRAWN BY: BK/NR
SURVEYED BY:
SURVEY DATE:

SHEET NAME: WATER MAIN PLAN AND PROFILE - 32+00 - 36+00
SHEET NO: 23

COLOUR PANS: SEE PROJECT

P:\3-110 - RRD Railroad Avenue Water Main Extension\3-110-011 - Engineering\Drawings\Sheet\DWG 2/19/2025.dwg

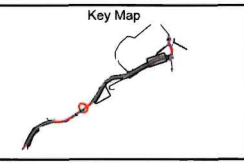
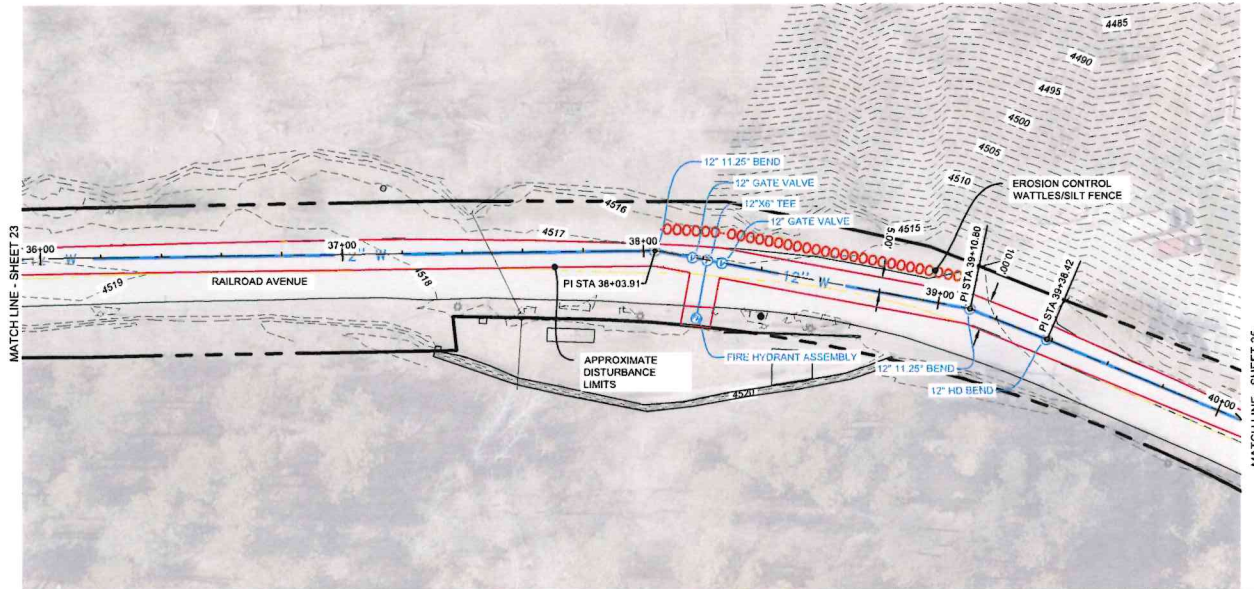

NOTE:
CONTRACTOR TO SAW CUT AND REMOVE ASPHALT NECESSARY TO INSTALL WATER MAIN
CONTRACTOR TO REPLACE TOP SURFACING AS A 1 TO 1 EQUAL.

WATER MAIN NOTES			
STATION	OFFSET	T.O.P. ELEV	ITEM DESC
38+02.91	0.00'	4510.00	12" 11.25° BEND
38+16.67	0.00'	4510.09	12" GATE VALVE
38+21.67	0.00'	4510.13	12" X6" TEE
38+26.67	0.00'	4510.16	12" GATE VALVE
39+10.00	0.00'	4510.00	12" 11.25° BEND
39+38.42	0.00'	4509.87	12" HD BEND

INSTALL YARD HYDRANT	
DESCRIPTION	
FIRE HYDRANT ASSEMBLY STA 38+21.67 - 19.71' R	FG ELEV = 4517.63' INV ELEV = 4509.38' BURY DEPTH = 8.25'

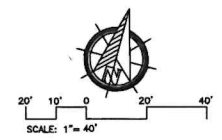
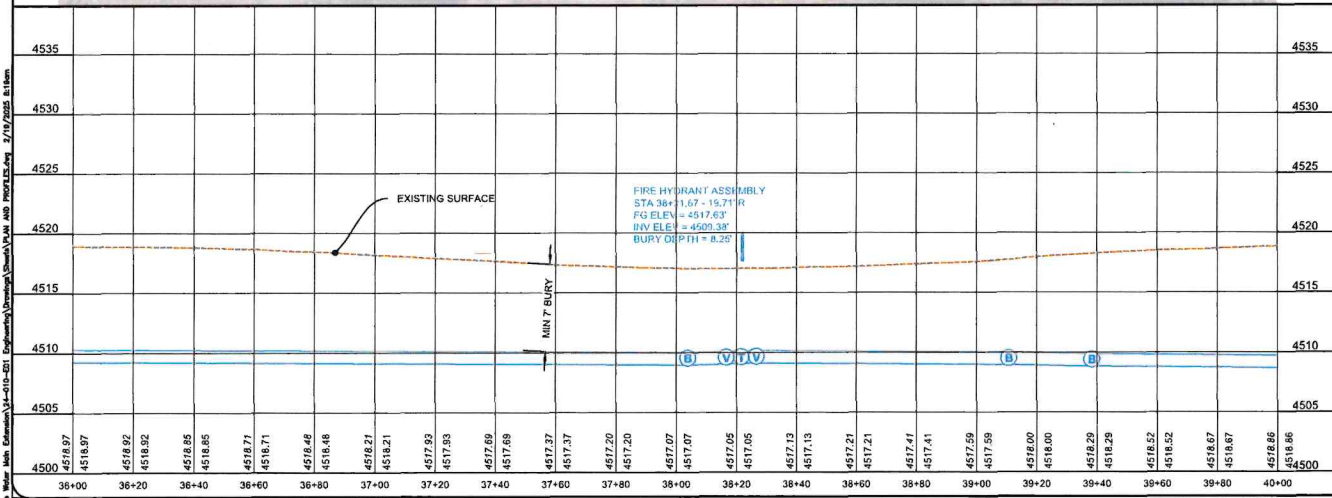
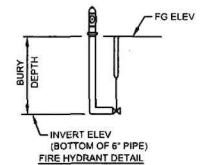

TDG
Towey Design Group, Inc.
147 Chisholm Drive
Box Elder, SD 57719
605.600.3758

LOGO:

**DEADWOOD RAILROAD AVENUE
WATER MAIN EXTENSION
DEADWOOD, SOUTH DAKOTA**

REVISIONS:

35% DESIGN PLANS
95% DESIGN PLANS

JOB NUMBER: 24-010

DESIGNED BY: BK
DRAWN BY: BK/NR
SURVEYED BY:
SURVEY DATE:

**SHEET NAME:
WATER MAIN PLAN AND
PROFILE - 36+00 - 40+00**

SHEET NO: **24**

PLAN 24-010 - 200 Deadwood Avenue, Deadwood, SD 57719
 Engineering: (605) 606-3758
 Survey: (605) 606-3758
 Date: 12/15/2010
 Scale: 1" = 40'

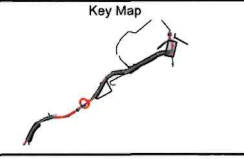
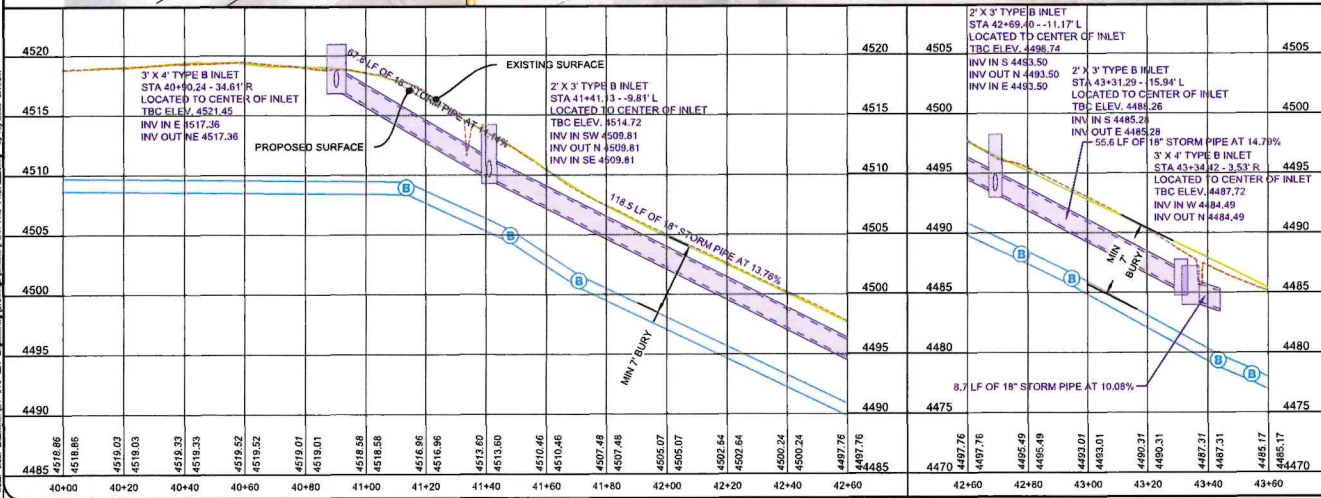
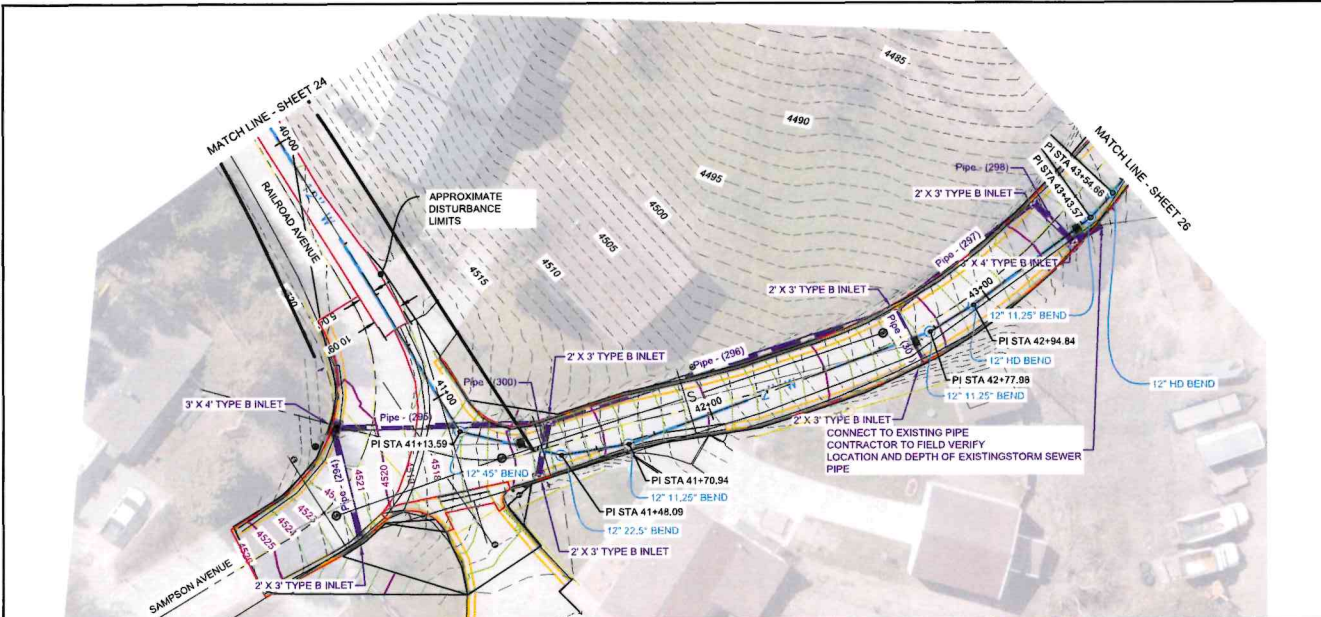

NOTE
 CONTRACTOR TO SAW CUT AND REMOVE ASPHALT NECESSARY TO INSTALL WATER MAIN
 CONTRACTOR TO REPLACE TOP SURFACING AS A 1 TO 1 EQUAL.

WATER MAIN NOTES			
STATION	OFFSET	T.O.P. ELEV.	ITEM DESC
41+13.59	0.00'	4509.43	12" 45' BEND
41+48.09	0.00'	4505.41	12" 22.5' BEND
41+70.94	0.00'	4501.52	12" 11.25' BEND
42+77.98	0.00'	4488.89	12" 11.25' BEND
42+94.84	0.00'	4486.63	12" HD BEND
43+43.57	0.00'	4479.83	12" 11.25' BEND
43+54.66	0.00'	4478.55	12" HD BEND

STORM SEWER NOTES			
STATION	OFFSET	INV. ELEV.	ITEM DESC
40+90.24	34.61'R	Pipe - (294): 4517.36' - In Pipe - (295): 4517.36' - Out	3' x 4' TYPE B INLET
41+13.59	48.56'R	Pipe - (294): 4516.86' - Out	2' x 3' TYPE B INLET
41+41.13	9.81'L	Pipe - (295): 4509.81' - In Pipe - (296): 4509.81' - In Pipe - (300): 4509.81' - In	2' x 3' TYPE B INLET
41+42.76	8.51'R	Pipe - (300): 4509.99' - Out	2' x 3' TYPE B INLET
42+69.40	11.17'L	Pipe - (296): 4493.50' - In Pipe - (297): 4493.50' - Out Pipe - (301): 4493.50' - In	2' x 3' TYPE B INLET
42+71.98	8.25'R	Pipe - (301): 4493.70' - Out	2' x 3' TYPE B INLET
43+31.29	15.94'L	Pipe - (297): 4485.28' - In Pipe - (298): 4485.28' - Out	2' x 3' TYPE B INLET
43+34.42	3.53'R	Pipe - (298): 4484.49' - In Pipe - (299): 4484.49' - Out	3' x 4' TYPE B INLET
43+44.27	4.56'R	Pipe - (299): 4483.61' - In	CONNECT TO EXISTING PIPE CONTRACTOR TO FIELD VERIFY LOCATION AND DEPTH OF EXISTING STORM SEWER PIPE

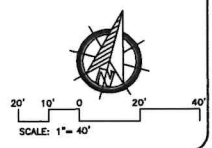

TDG Towey Design Group, Inc.
 147 Chisholm Drive
 Box Elder, SD 57719
 605.600.3758

LOGO:

**DEADWOOD RAILROAD AVENUE
 WATER MAIN EXTENSION
 DEADWOOD, SOUTH DAKOTA**

REVISIONS:
 35% DESIGN PLANS
 95% DESIGN PLANS

JOB NUMBER: 24-010
 DESIGNED BY: BK
 DRAWN BY: BKNR
 SURVEYED BY:
 SURVEY DATE:

**SHEET NAME:
 WATER MAIN PLAN AND
 PROFILE - 40+00 - 43+60**
 SHEET NO. **25**

1511-CDD-001-PLANS - 08/21/2019 - 2:19 PM

P:\31-010 - 080 Railroad Avenue Water Main Extension\31-010-081 - 080 Railroad Avenue Water Main Extension\Drawings\31-010-081 - 080 Railroad Avenue Water Main Extension.dwg

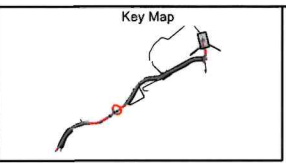
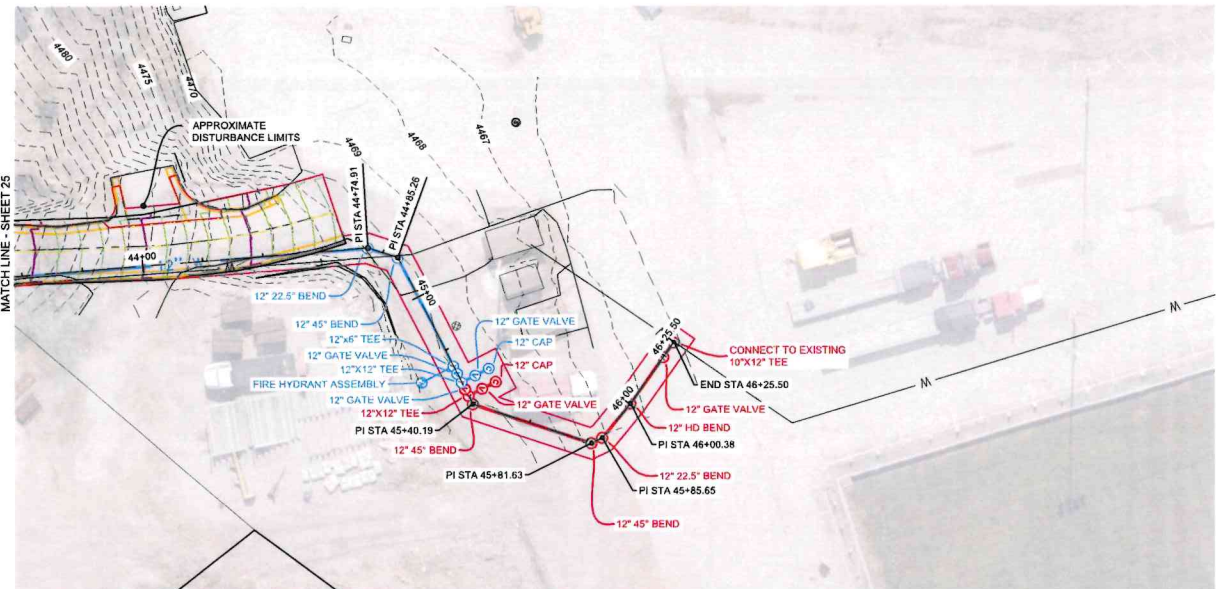

NOTE:
CONTRACTOR TO SAW CUT AND REMOVE ASPHALT NECESSARY TO INSTALL WATER MAIN.
CONTRACTOR TO REPLACE TOP SURFACING AS A 1 TO 1 EQUAL.
THE EXISTING WATERMAIN CONNECTION POINT HAS A 284PSI RESIDUAL PRESSURE. CONTRACTOR TO COORDINATE WITH CITY UTILITIES AND RESIDENTS FOR CONNECTION.

WATER MAIN NOTES			
STATION	OFF-SET	I.O.P. ELEV	ITEM DESC
44+74.91	0.00'	4463.62	12" 22.5" BEND
44+85.26	0.10'L	4463.08	12" 45" BEND
45+25.91	11.92'R	4462.49	FIRE HYDRANT ASSEMBLY
45+25.92	0.92'L	4462.74	12"x6" TEE
45+28.73	0.02'L	4462.71	12" GATE VALVE
45+40.19	0.00'	4462.62	12" 45" BEND
45+81.63	0.00'	4462.62	12" 45" BEND
45+85.65	0.00'	4462.62	12" 22.5" BEND
46+00.38	0.00'	4462.67	12" HD BEND
46+19.48	0.00'	4462.62	12" GATE VALVE
46+25.50	0.00'	4462.62	CONNECT TO EXISTING 10"x12" TEE

INSTALL YARD HYDRANT	
DESCRIPTION	
FIRE HYDRANT ASSEMBLY STA 45+25.91 - 11.92' R	FG ELEV = 4470.36' INV ELEV = 4461.99' BURY DEPTH = 8.37'

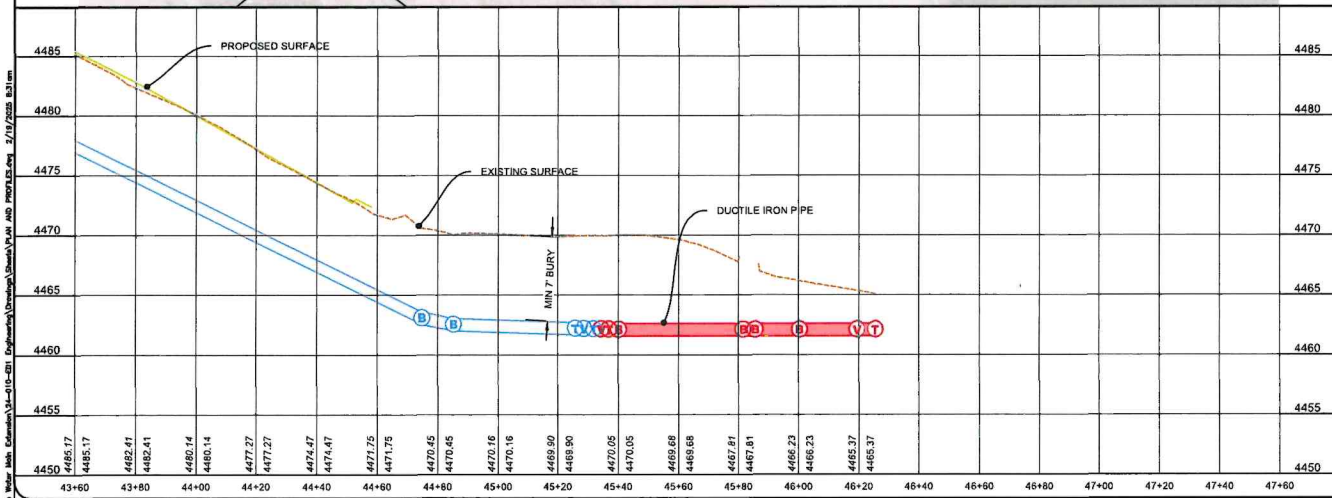
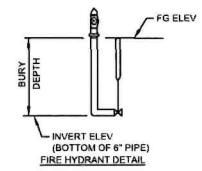

Towey Design Group, Inc.
147 Chisholm Drive
Box Elder, SD 57719
605.600.3758

LOGO



DEADWOOD RAILROAD AVENUE
WATER MAIN EXTENSION
DEADWOOD, SOUTH DAKOTA

REVISIONS:
35% DESIGN PLANS
95% DESIGN PLANS

JOB NUMBER: 24-010
DESIGNED BY: BK
DRAWN BY: BK/NR
SURVEYED BY:
SURVEY DATE:

SHEET NAME: WATER MAIN PLAN AND PROFILE - 43+60 - END
SHEET NO: 26

05/04/2024 11:15:00 AM
 2/17/2025 8:15am
 P:\24-010 - 240 Railroad Avenue Water Main Extension\24-010-001 Engineering\Drawings\Sheet\24010-001-27.dwg
 2/17/2025 8:15am

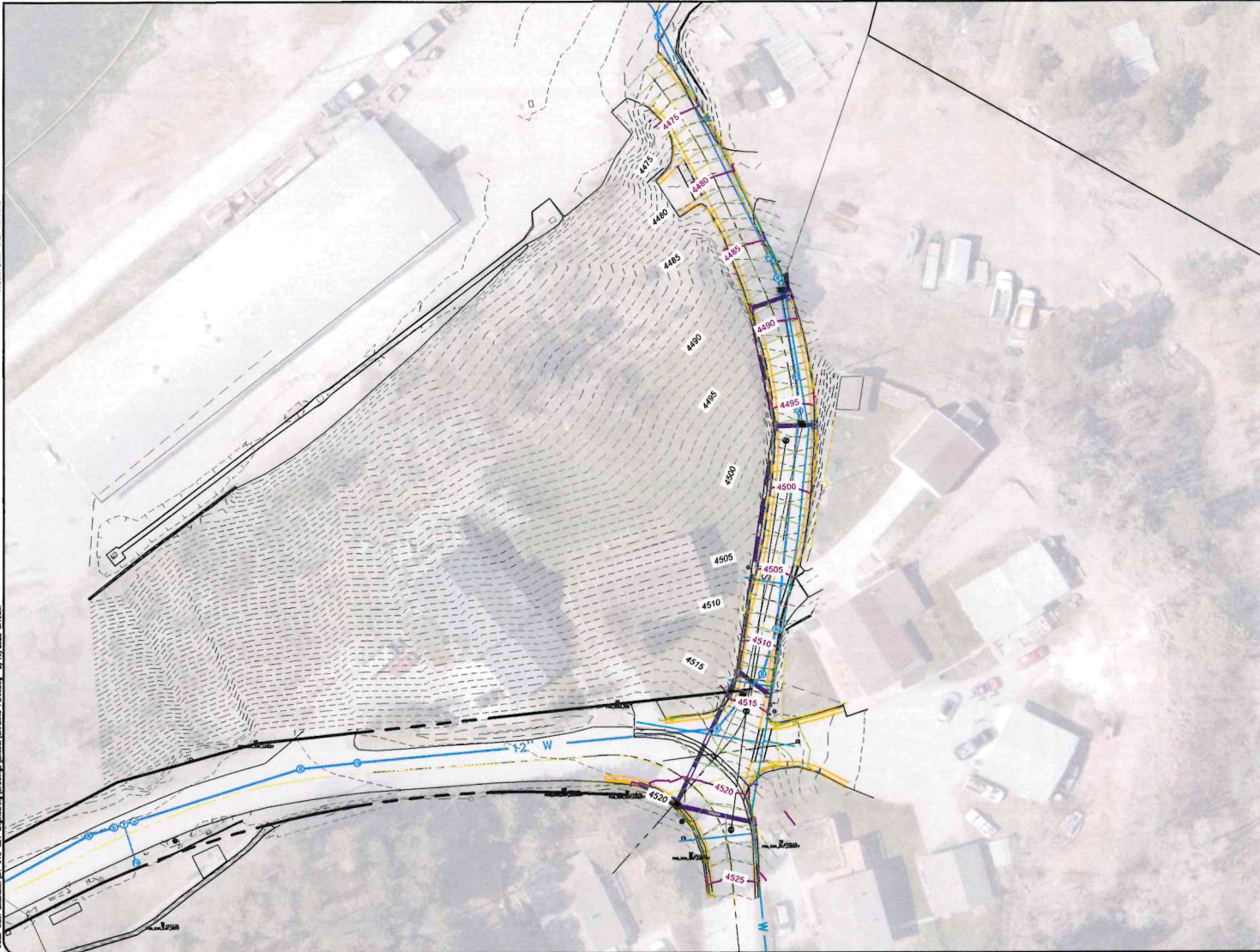

LEGEND

	3245	PROPOSED INDEX CONTOUR
	3242	PROPOSED INTERMEDIATE CONTOUR
	3245	EXISTING INDEX CONTOUR
	3242	EXISTING INTERMEDIATE CONTOUR
		CONTOUR INTERVAL = 1'
		DRAINAGE FLOW

GRADING QUANTITIES TABLE

1) PROPOSED SITE GRADING	502 CUBIC YARDS	CUT
	3,454 CUBIC YARDS	FILL*
	3,452 CUBIC YARDS	NET
	* FACTOR=20%	

*CUT AND FILL QUANTITIES ARE BASED ON A TOP OF SURFACE TO A TOP OF SURFACE COMPARISON

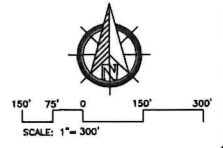

Towey Design Group, Inc.
 147 Chisholm Drive
 Box Elder, SD 57719
 605.600.3758

LOGO:



DEADWOOD RAILROAD AVENUE
WATER MAIN EXTENSION
DEADWOOD, SOUTH DAKOTA

REVISIONS:

35% DESIGN PLANS
95% DESIGN PLANS

JOB NUMBER: 24-010

DESIGNED BY: BK
DRAWN BY: BK/NR
SURVEYED BY:
SURVEY DATE:

SHEET NAME:

GRADING PLAN
SHEET NO: 27

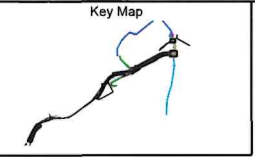
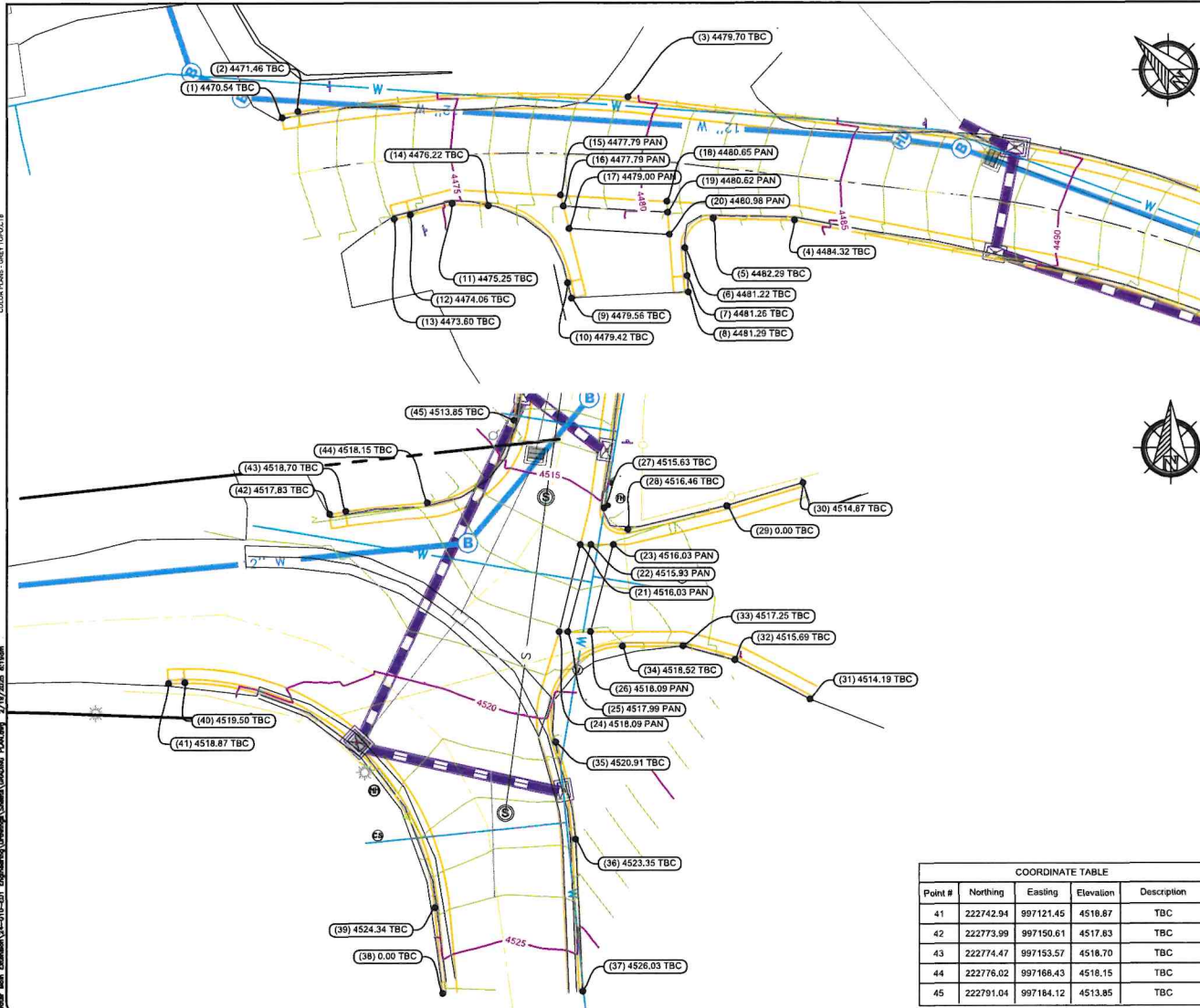

COORDINATE TABLE				
Point #	Northing	Easting	Elevation	Description
1	223098.01	997148.01	4470.54	TBC
2	223096.14	997150.45	4471.46	TBC
3	223045.60	997182.96	4479.70	TBC
4	223007.96	997178.77	4484.32	TBC
5	223020.92	997171.63	4482.29	TBC
6	223022.62	997164.41	4481.22	TBC
7	223019.69	997160.17	4481.26	TBC
8	223017.98	997157.71	4481.28	TBC
9	223035.92	997145.96	4479.56	TBC
10	223037.95	997148.03	4479.42	TBC
11	223063.35	997150.01	4475.25	TBC
12	223068.90	997144.42	4474.06	TBC
13	223071.02	997142.29	4473.60	TBC
14	223057.49	997152.98	4476.22	TBC
15	223047.14	997161.23	4477.79	PAN
16	223045.68	997159.73	4477.79	PAN
17	223042.74	997156.74	4479.00	PAN
18	223029.77	997170.05	4480.65	PAN
19	223028.63	997168.39	4480.62	PAN
20	223026.33	997165.07	4480.98	PAN
21	222768.27	997196.19	4516.03	PAN
22	222768.27	997198.10	4515.93	PAN
23	222768.27	997202.23	4516.03	PAN
24	222752.28	997192.35	4518.09	PAN
25	222752.28	997193.92	4517.99	PAN
26	222752.28	997198.06	4518.09	PAN
27	222775.00	997200.54	4515.63	TBC
28	222771.03	997204.89	4516.46	TBC
29	222775.38	997222.96	0.00	TBC
30	222779.55	997236.83	4514.87	TBC
31	222739.85	997238.12	4514.19	TBC
32	222747.08	997224.46	4515.69	TBC
33	222749.64	997215.02	4517.25	TBC
34	222749.62	997203.95	4518.52	TBC
35	222732.12	997191.77	4520.91	TBC
36	222714.32	997195.39	4523.35	TBC
37	222686.49	997196.71	4526.03	TBC
38	222686.15	997171.29	0.00	TBC
39	222701.82	997169.87	4524.34	TBC
40	222743.06	997124.45	4519.50	TBC

COORDINATE TABLE				
Point #	Northing	Easting	Elevation	Description
41	222742.94	997121.45	4518.87	TBC
42	222773.99	997150.61	4517.83	TBC
43	222774.47	997153.57	4518.70	TBC
44	222776.02	997166.43	4518.15	TBC
45	222791.04	997164.12	4513.85	TBC

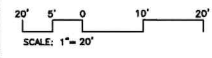

P:\14-010 - 2002 Railroad Avenue Water Main Extension\14-010-021 - Engineering\Drawings\Sheet\021\021.dwg 7/14/2015 8:14 am
 C:\Users\mcc\OneDrive\Documents\14-010-021.dwg



Towey Design Group, Inc.
 147 Chisholm Drive
 Box Elder, SD 57719
 605.600.3758

LOGO:



DEADWOOD RAILROAD AVENUE
WATER MAIN EXTENSION
DEADWOOD, SOUTH DAKOTA

REVISIONS:
 35% DESIGN PLANS
 95% DESIGN PLANS

JOB NUMBER: 24-010
 DESIGNED BY: BK
 DRAWN BY: BKNR
 SURVEYED BY:
 SURVEY DATE:

SHEET NAME:
INTERSECTION PLAN
 SHEET NO:
28

