

OFFICE OF  
**PLANNING, ZONING AND  
 HISTORIC PRESERVATION**  
 108 Sherman Street  
 Telephone (605) 578-2082  
 Fax (605) 578-2084



FOR OFFICE USE ONLY	
Case No	<u>240056</u>
<input type="checkbox"/> Project Approval	
<input checked="" type="checkbox"/> Certificate of Appropriateness	
Date Received	<u>04/17/24</u>
Date of Hearing	<u>04/24/24</u>

## City of Deadwood Application for Project Approval OR Certificate of Appropriateness

The Deadwood Historic Preservation Commission reviews all applications. Approval is issued for proposed work in keeping with City of Deadwood Ordinances & Guidelines, South Dakota State Administrative Rules and the Secretary of the Interior's Standards for Rehabilitation.

This application must be typed or printed in ink and submitted to:

City of Deadwood  
 Deadwood Historic Preservation Office  
 108 Sherman Street  
 Deadwood, SD 57732

FOR INFORMATION REGARDING THIS FORM, CALL 605-578-2082

PROPERTY INFORMATION
Property Address: <u>709 Main Street</u>
Historic Name of Property (if known): <u>The Franklin Hotel</u>

APPLICANT INFORMATION
Applicant is: <input checked="" type="checkbox"/> owner <input type="checkbox"/> contractor <input type="checkbox"/> architect <input type="checkbox"/> consultant <input type="checkbox"/> other _____

Owner's Name: <u>Grant Lincoln, SGMSD, LLC</u>
Address: <u>3101 S Russell</u>
City: <u>Missula</u> State: <u>MT</u> Zip: <u>59801</u>
Telephone: <u>406-546-6655</u> Fax: _____   E-mail: <u>grant@strategicgaming.biz</u>

Architect's Name: <u>CHAMBERLIN ARCHITECTS</u>
Address: <u>725 ST. JOSEPH ST, STE. B1</u>
City: <u>RAPID CITY</u> State: <u>SD</u> Zip: <u>57701</u>
Telephone: <u>605-355-6804</u> Fax: _____   E-mail: <u>bburns@chamberlinarchitects.com</u>

Contractor's Name: <u>TBD</u>
Address: _____
City: _____ State: _____ Zip: _____
Telephone: _____ Fax: _____ E-mail: _____

Agent's Name: _____
Address: _____
City: _____ State: _____ Zip: _____
Telephone: _____ Fax: _____ E-mail: _____

TYPE OF IMPROVEMENT			
<input type="checkbox"/> Alteration (change to exterior)	<input type="checkbox"/> New Building	<input type="checkbox"/> Addition	<input type="checkbox"/> Accessory Structure
<input type="checkbox"/> New Construction	<input type="checkbox"/> Re-Roofing	<input type="checkbox"/> Wood Repair	<input type="checkbox"/> Exterior Painting
<input type="checkbox"/> General Maintenance	<input type="checkbox"/> Siding	<input checked="" type="checkbox"/> Windows	<input type="checkbox"/> Porch/Deck
<input type="checkbox"/> Other _____	<input type="checkbox"/> Awning	<input type="checkbox"/> Sign	<input type="checkbox"/> Fencing

**ACTIVITY: (CHECK AS APPLICABLE)**

Project Start Date: SOON Project Completion Date (anticipated): TBD

**ALTERATION**     Front     Side(s)     Rear

**ADDITION**     Front     Side(s)     Rear

**NEW CONSTRUCTION**     Residential     Other \_\_\_\_\_

**ROOF**     New     Re-roofing     Material  
 Front     Side(s)     Rear     Alteration to roof

**GARAGE**     New     Rehabilitation  
 Front     Side(s)     Rear

**FENCE/GATE**     New     Replacement  
 Front     Side(s)     Rear  
Material \_\_\_\_\_ Style/type \_\_\_\_\_ Dimensions \_\_\_\_\_

**WINDOWS**     **STORM WINDOWS**     **DOORS**     **STORM DOORS**  
 Restoration     Replacement     New  
 Front     Side(s)     Rear  
Material \_\_\_\_\_ Style/type \_\_\_\_\_

**PORCH/DECK**     Restoration     Replacement     New  
 Front     Side(s)     Rear  
Note: Please provide detailed plans/drawings

**SIGN/AWNING**     New     Restoration     Replacement  
Material \_\_\_\_\_ Style/type \_\_\_\_\_ Dimensions \_\_\_\_\_

**OTHER** – Describe in detail below or use attachments

**DESCRIPTION OF ACTIVITY**

Describe in detail, the above activity (use attachments if necessary including type of materials to be used) and submit as applicable. Descriptive materials such as photos and drawings are necessary to illustrate the work and to help the commissioners and staff evaluate the proposed changes. Information should be supplied for each element of the proposed work along with general drawings and/or photographs as appropriate.

Failure to supply adequate documentation could result in delays in processing and denial of the request. Describe in detail below (add pages as necessary).

All double-hung window in the building will be replaced. The existing historical frames will remain and repaired where necessary. New wood single hung windows will be installed within the existing frames.

See attached preliminary submittal from Pella for product information and detail.

**SIGNATURES**

**I HEREBY CERTIFY** I understand this application will not be accepted and processed until all the requested information has been supplied. I realize drawings and measurements must be exact and if errors result in a violation of the Commission's approval, then appropriate changes will have to be made. I also understand this application may require a site visit / additional research by staff and a PUBLIC HEARING by the DEADWOOD HISTORIC PRESERVATION COMMISSION.

I understand this application is for a Certificate of Appropriateness or Project Approval only and that a building permit is required for any uses associated with this location prior to any constructions, alterations, etc. All statements are true to the best of my knowledge and belief.

I understand approval is issued for proposed work in keeping with City of Deadwood Ordinances, South Dakota State Administrative Rules and the Secretary of the Interior's Standards for Rehabilitation and copies are available for my review.

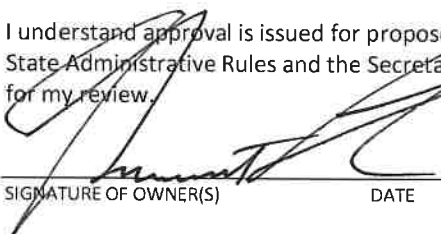
 SIGNATURE OF OWNER(S)	DATE	4.17.24 SIGNATURE OF AGENT(S)	DATE
--	------	----------------------------------	------

SIGNATURE OF OWNER(S)	DATE	SIGNATURE OF AGENT(S)	DATE
-----------------------	------	-----------------------	------

SIGNATURE OF OWNER(S)	DATE	SIGNATURE OF AGENT(S)	DATE
-----------------------	------	-----------------------	------

**APPLICATION DEADLINE**

This form and all supporting documentation **MUST** arrive by 5:00 p.m. on the 1<sup>st</sup> or 3<sup>rd</sup> Wednesday of every month to be considered at the next Historic Preservation Commission Meeting. The meeting schedule and filing deadlines are on file with the Historic Preservation Office. Any information not provided to staff in advance of the meeting will not be considered by the Commission during their deliberation. Please call if you have any questions and staff will assist you.

**Please use the attached criteria checklist as a guide to completing the application.** Incomplete applications cannot be reviewed and will be returned to you for more information. All submitted materials will be retained by the Historic Preservation Office. Do not submit your only copy of any piece of documentation.

The City of Deadwood Historic Preservation Office has numerous resources available for your assistance upon request.

# Criteria Checklist for Project Approval OR Certificate of Appropriateness

## SUBMITTAL CRITERIA CHECKLIST

The documentation listed below will assist in the submission of the application. *Not all information listed below is required for each project. In order to save time and effort, please consult with the Historic Preservation Office prior to completing your application.*

### ALL WORK:

- Photograph of house and existing conditions from all relevant sides.

### RENOVATIONS AND ADDITIONS:

- Elevation and plan drawings to scale indicating proposed alterations or additions, clearly indicating the existing building and what is proposed and including the relationship to adjacent structures. Make sure to include door and window design if altered. Manufacturer's catalog data may be used, if applicable.
- Exterior material description.
- Site plan showing dimensions of lot and location of existing building(s) or structure(s) on lot, location of additions, dimensions of existing structure and additions. (Show use of addition and location of windows and doors if applicable.)
- Photograph of existing conditions from all elevations.
- Color samples and placement on the structure.
- Historic photographs should accompany any request to return a structure to an earlier historic appearance. (Please note our archives may be of great assistance)

### MATERIAL CHANGES:

- Written description of area involved.
- Color photographs or slides of areas involved and surrounding structures if applicable.
- Sample or photo of materials involved.

### PAINTING, SIDING:

- Color photographs of all areas involved and surrounding structures if applicable.
- Samples of colors and/or materials to be used.
- Dimensioned elevation and section to scale, showing design of fence, material, and height in relationship to adjacent structures.

### NEW CONSTRUCTION:

- Elevation drawings to scale showing all sides and dimensions. Elevation drawings to scale showing relationship to structures immediately adjacent.
- Photograph of proposed site and adjacent buildings on adjoining properties.
- Site plan including building footprint and location of off-street parking showing setbacks. Include number of spaces, surface material, screening and all other information required under Parking Areas.
- Material list including door and window styles, colors and texture samples.
- Scale model indicating significant detail. (This may be required for major construction. Please consult Historic Preservation Commission staff.)
- Color photographs of proposed site and structures within vicinity of new building.

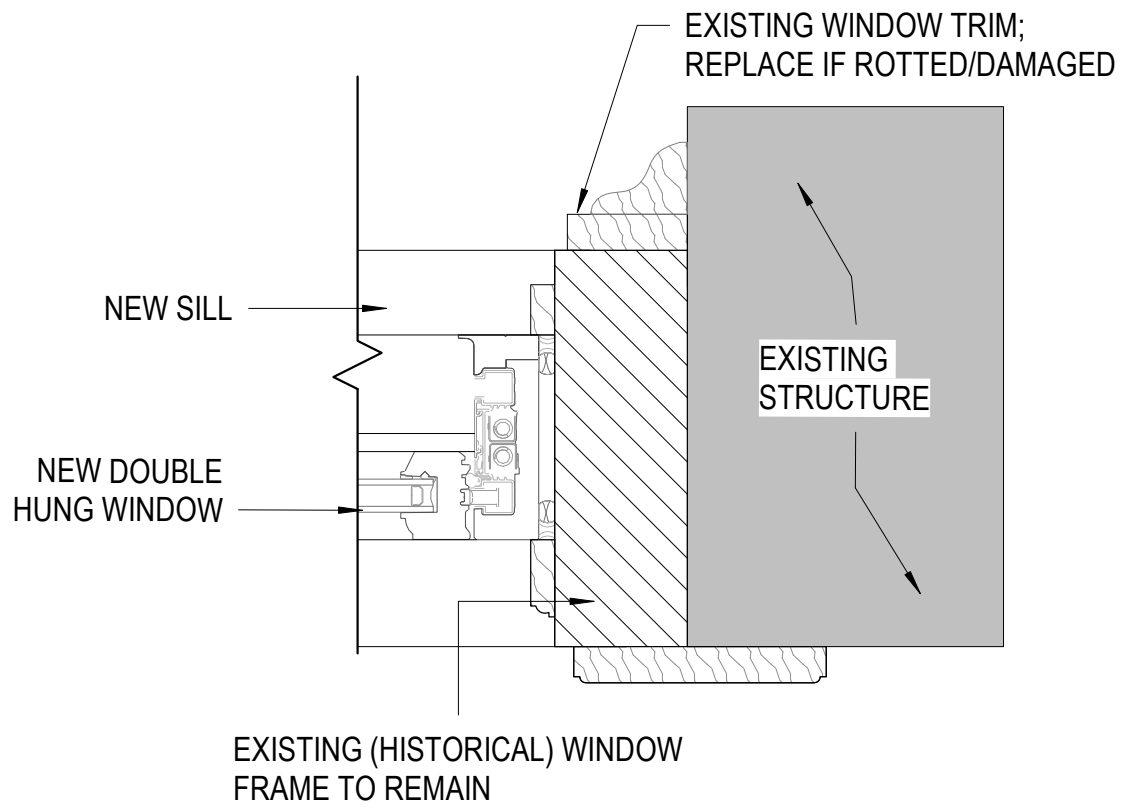

1 HEAD/JAM DETAIL #1

ASK-02

0' 3" 6"

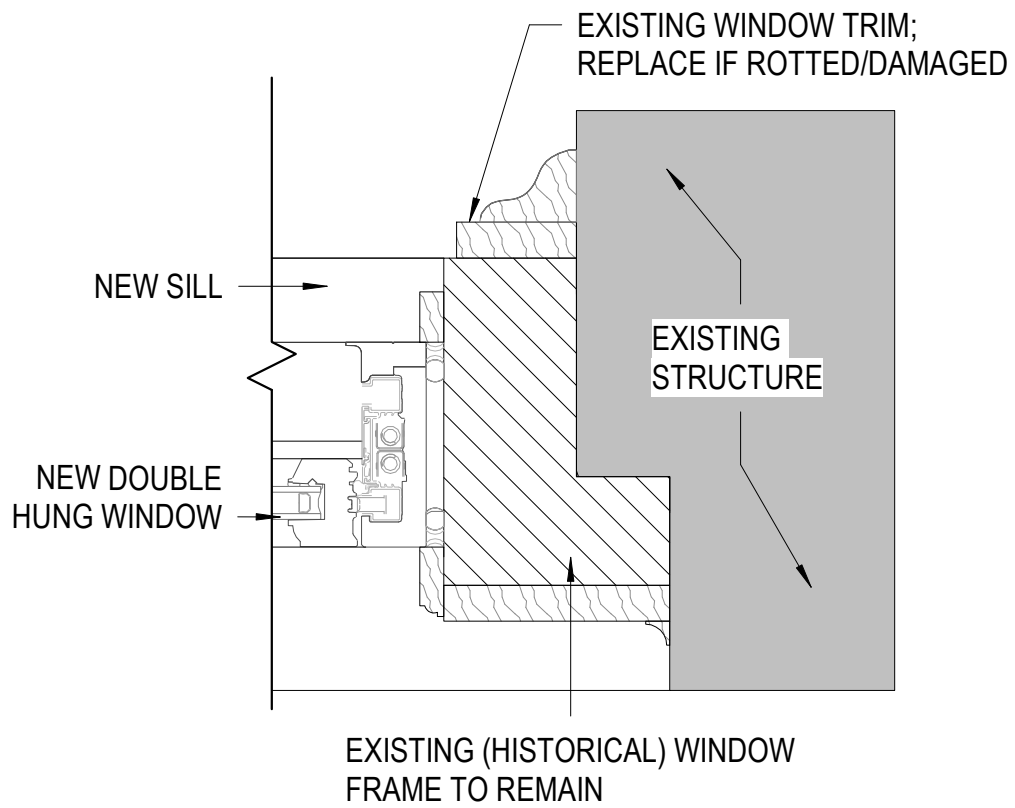

1 HEAD/JAM DETAIL #2

ASK-03

0" 3" 6"

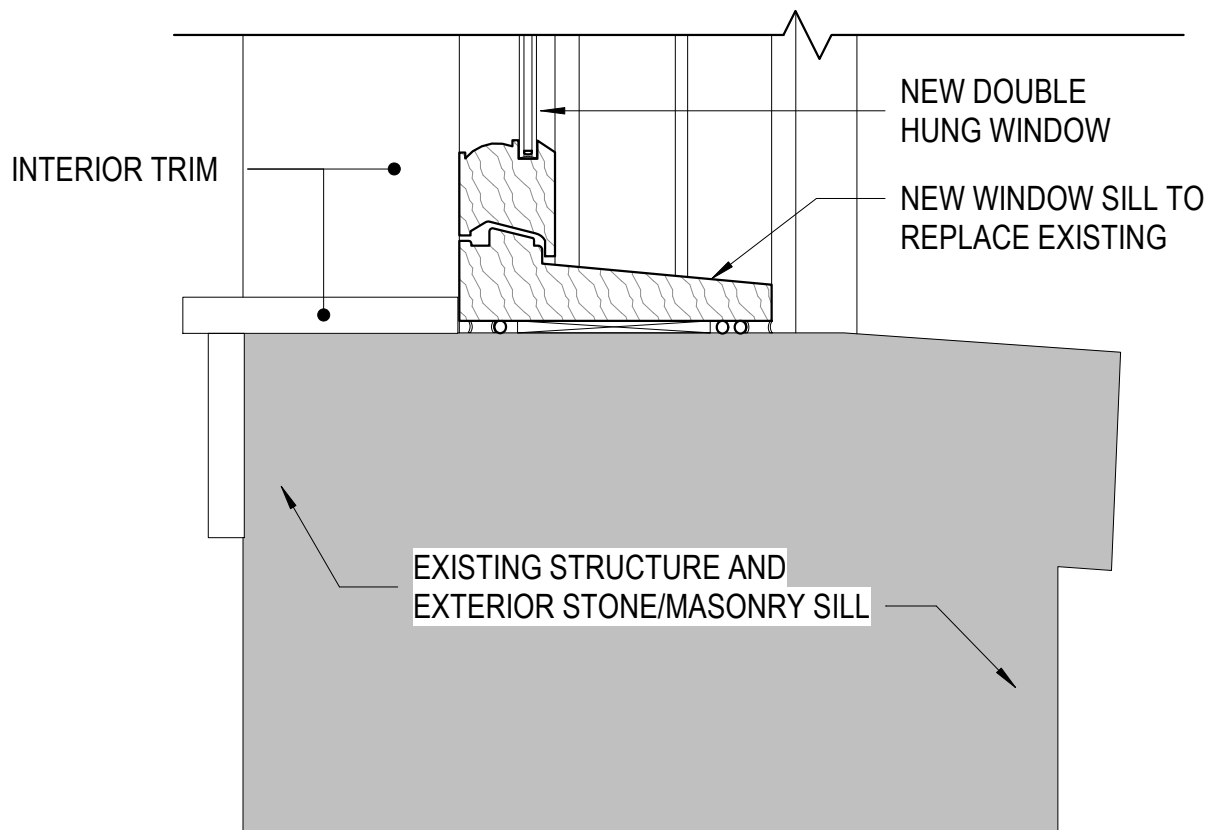

1 SILL DETAIL

ASK-01

0' 3" 6"



# Windows & Doors

## **Submittal**

-Franklin Hotel Remodel-

**-WINDOWS-**



## Product Guide Specification

### SECTION 08 52 13

### WOOD WINDOWS

#### PART 1 GENERAL

##### 1.1 SECTION INCLUDES

- A. [Factory-primed] wood [hung] windows.

##### 1.2 RELATED SECTIONS

- A. Section 07270 (07 27 00) - Air Barriers: Water-resistant barrier.
- B. Section 07920 (07 92 00) - Joint Sealants: Sealants and caulking.

##### 1.4 PERFORMANCE REQUIREMENTS

- A. Windows shall be Hallmark certified to a rating of [CW]-PG[ 30-45 ] specifications in accordance with ANSI/AAMA/NWDA 101/I.S.2/A440-08 or ANSI/AAMA/NWDA 101/I.S.2/A440-11.
- B. Window Unit Air Leakage, ASTM E 283, 1.57 psf (25 mph): 0.05 cfm per square foot of frame or less.
- C. Window Unit Water Penetration: No water penetration through window unit when tested in accordance with ASTM E 547, under static pressure of 7.5 psf (52 mph) after 4 cycles of 5 minutes each, with water being applied at a rate of 5 gallons per hour per square foot.

##### 1.5 SUBMITTALS

- A. Comply with Division 1 requirements.
- B. Product Data: Submit manufacturer's product data, including installation instructions.
- C. Shop Drawings: Submit manufacturer's shop drawings, indicating dimensions, construction, component connections and locations, anchorage methods and locations, hardware locations, and installation details.
- D. Warranty: Submit manufacturer's standard warranty.

##### 1.7 DELIVERY, STORAGE, AND HANDLING

- A. Delivery: Deliver materials to site undamaged in manufacturer's or sales branch's original, unopened containers and packaging, with labels clearly identifying manufacturer and product name. Include installation instructions.

- B. Storage: Store materials in an upright position, off ground, under cover, and protected from weather, direct sunlight, and construction activities.
- C. Handling: Protect materials and finish during handling and installation to prevent damage.

## **PART 2 PRODUCTS**

### **2.1 MANUFACTURER**

- A. Pella Corporation, 102 Main Street, Pella, Iowa 50219. Toll Free (800) 54-PELLA. Phone (641) 621-1000. Website [www.pella.com](http://www.pella.com).

### **2.2 WOOD WINDOWS**

- C. Wood Monumental [Single-Hung] Windows: Pella factory-assembled with sash [in unit].
  - 1. Frame:
    - a. Select softwood, water-repellent, preservative-treated with EnduraGuard® in accordance with WDMA I.S.-4. EnduraGuard includes water-repellency, three active fungicides and an insecticide applied to the frame.
    - b. Interior Exposed Surfaces: [Clear Pine] with no visible fastener holes.
    - c. Exterior Surfaces: [Factory Primed].
    - d. Overall Frame Depth: 5-7/8" (149 mm).
  - 2. Sash:
    - a. Select softwood, water-repellent, preservative-treated with EnduraGuard in accordance with WDMA I.S.-4. EnduraGuard includes water-repellency, three active fungicides and an insecticide applied to the sash.
    - b. Interior Exposed Surfaces: [Clear Pine] with no visible fastener holes.
    - c. Exterior Surfaces: [Factory Primed].
    - d. Exterior sash profile is putty.
    - e. Corners: Mortised and tenoned, glued and secured with metal fasteners.
    - f. Sash Thickness: 2-1/4" (57 mm).
  - 3. Weather Stripping:
    - a. Santoprene-wrapped foam at head and sill.
    - b. Full length glass filled polypropylene interlocker with integrated slip-coated thermoplastic elastomer leaf.
    - c. Secondary nylon bristle rain strip on bottom sash at sill.
    - d. Vinyl-wrapped foam with secondary nylon bristle rain strip inserted into jamb liner to seal against sides of sash.

### **2.3 GLAZING**

- A. Glazing:
  - 1. Float Glass: ASTM C 1036, Quality 1.
    - a. Tempered Glass (Select units): ASTM C 1048.
  - 2. Type: Silicone-glazed 11/16-inch dual-seal, [annealed] [tempered] insulating glass, [multi-layer Low-E coated with argon].

### **2.5 HARDWARE**

- A. Hung

1. Balances:
  - a. Block-and-tackle balances.
  - b. Balances are attached to frame and connected to sash with polyester cord.
2. Locking System:
  - a. [Spoon-shaped sash lock.]
  - b. One installed on units with frame width less than 37 inches, 2 locks installed on units with frame width of 37 inches or greater.
3. Sash Lifts:
  - a. Sash lift furnished for field installation.
  - b. One sash lift on units with frame width less than 37 inches, 2 sash lifts on units with frame width of 37 inches or greater.
4. Lock and Sash Lift Finish: [Baked enamel, [White].

## 2.6 TOLERANCES

- A. Windows shall accommodate the following opening tolerances:
  1. Vertical Dimensions Between High and Low Points: Plus 1/4 inch, minus 0 inch.
  2. Width Dimensions: Plus 1/4 inch, minus 0 inch.
  3. Building Columns or Masonry Openings: Plus or minus 1/4 inch from plumb.

## 2.7 FINISH

- A. Interior Finish: [Factory finished with 1 prime coat and 1 top coat of [White].  
Factory Painted White

## PART 3 EXECUTION

### 3.1 EXAMINATION

- A. Examine areas to receive windows. Notify Architect of conditions that would adversely affect installation or subsequent use. Do not proceed with installation until unsatisfactory conditions are corrected.

### 3.2 INSTALLATION

- A. Install windows in accordance with manufacturer's instructions and approved shop drawings.
- B. Install windows to be weather-tight and freely operating.
- C. Maintain alignment with adjacent work.
- D. Secure assembly to framed openings, plumb and square, without distortion.
- E. Integrate window system installation with exterior water-resistant barrier using flashing/sealant tape. Apply and integrate flashing/sealant tape with water-resistant barrier using watershed principles in accordance with window manufacturer's instructions.
- F. Place interior seal around window perimeter to maintain continuity of building thermal and air barrier using [backer rod and sealant] [insulating-foam sealant].  
.
- G. Seal window to exterior wall cladding with sealant and related backing materials at perimeter of assembly.
- H. Leave windows closed and locked.

### **3.4 CLEANING**

- A. Clean window frames and glass in accordance with Division 1 requirements.
- B. Do not use harsh cleaning materials or methods that would damage finish.
- C. Remove labels and visible markings.

### **3.5 PROTECTION**

- A. Protect installed windows to ensure that, except for normal weathering, windows will be without damage or deterioration at time of substantial completion.

**END OF SECTION**



# Pella® Reserve™ Traditional Hung Window

## Unit Sections - Wood Exterior Putty Glaze Exterior Profile

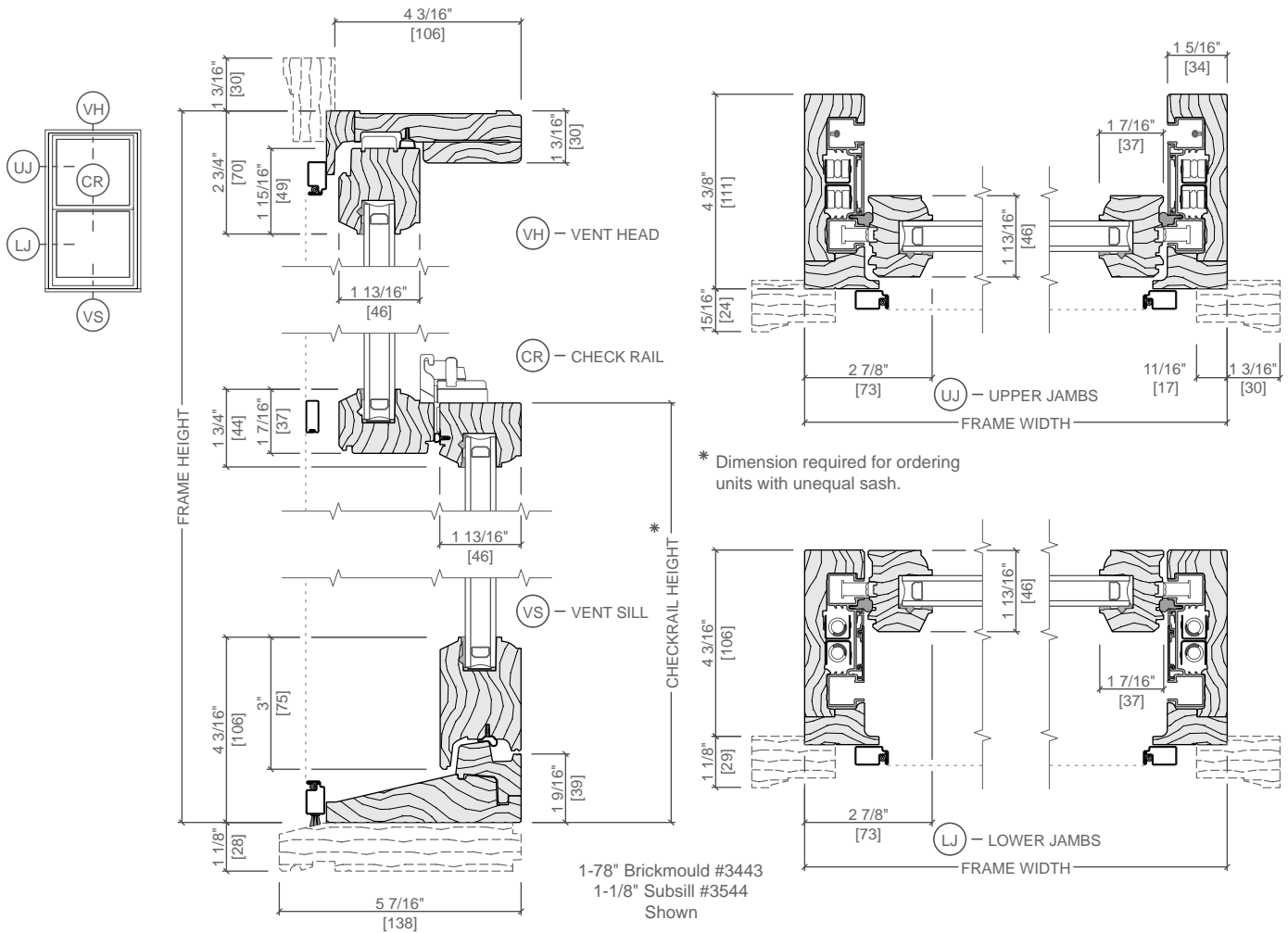

Scale 3" = 1' 0"

All dimensions are approximate.

## CURVED GLASS 90 DEGREE CORNER GLASS

We are able to provide our customers with a complete line of specialty window products and unlimited design options. We are proud to offer curved glass and 90 degree corner glass window units. On 90 degree corner window units, the frame will have a 90 degree corner. The glass corner will have a small (approx. two inch) radius corner.

### FEATURES

- Clad Available in Curved Glass Unit and 90 degree corner with post (Limited clad profiles & limited radius)
- Fixed Corner Post Option
- Primed or poly painted wood exteriors.
- Glass options include single or **insulated**, clear, **Low E**, and laminated.
- Jamb depths to your specifications.
- Interior trim and wood grilles to enhance the window units.
- All units are outside glazed.

Please call or fax for a quote.

Please note the following special glass warranty conditions:

- No stress crack warranty
- 5 year seal failure warranty

Please Note

QTY 12

Curved Glass Unit

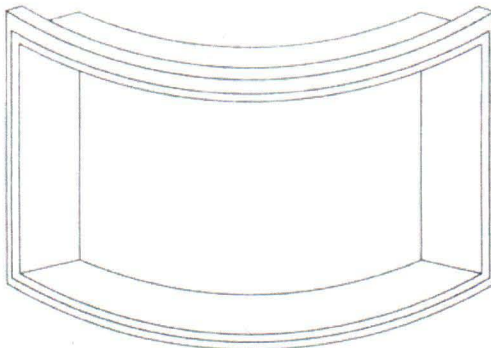

Curved Glass "Simulated Hung" Fixed Units

Customer Comments:

LineItem #	Unit Details	Quantity
100-1		1
WindowAndDoor		
Comment/Room:	2nd Floor - Unit is Curved Frame, Sash, and Glass Radius= 105"	
	Overall Frame: 47.5" X 104.25"	
	Overall RO: 48.5" X 104.75"	



Wood Direct Sets

Frame Width = 47.5, Frame Height = 104.25

Unit Type = Complete Unit, Unit Profile = Standard

- Frame -
- 3/4" x 4 9/16" Pine ,Unit Finishing (Exterior Is Poly Painted In PL - White ,Interior Is Ultra Primed). B13 Exterior Stops ,B13 Interior Stops.
- Casing Options -
- No Brickmold/Casing, No Subsill, Masonry Clips = 7.5" Masonry Clip, Applied
- Glass -
- 1" Insulated IGU Curved Pilkington LowE with Argon Gas Tempered with Black (Aluminum) spacer.
- Grilles -
- Simulated Divided Lite w/o Internal Spacer, Rectangular, Match Unit Materials & Finishes = Yes, Interior Bar Type = PVC, Interior Wood Grille Profile = CGR-7/8" 124 (4035), Exterior Bar Type = PVC (Stock PVC Profiles), Exterior Grille Profile = CGR-7/8" 124 (4035), SDL Tape Color = Gray, 1W2H
- Ratings -
- Performance Rating = Standard
- Threshold -

Curved Glass "Simulated Hung" Fixed Units

Customer Comments:

LineItem #	Unit Details	Quantity
------------	--------------	----------

200-1		1
WindowAndDoor		
Comment/Room:	2nd Floor - Unit is Curved Frame, Sash, and Glass Radius= 105"	
	Overall Frame: 47.5" X 88.75"	
	Overall RO: 48.5" X 89.25"	

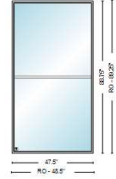

Wood Direct Sets

Frame Width = 47.5, Frame Height = 88.75

Unit Type = Complete Unit, Unit Profile = Standard

- Frame -  
3/4" x 4 9/16" Pine ,Unit Finishing (Exterior Is Poly Painted In PL - White ,Interior Is Ultra Primed). B13 Exterior Stops ,B13 Interior Stops.

- Casing Options -

No Brickmold/Casing, No Subsill, Masonry Clips = 7.5" Masonry Clip, Applied

- Glass -

1" Insulated IGU Curved Pilkington LowE with Argon Gas Tempered with Black (Aluminum) spacer.

- Grilles -

Simulated Divided Lite w/o Internal Spacer, Rectangular, Match Unit Materials & Finishes = Yes, Interior Bar Type = PVC, Interior Wood Grille Profile = CGR-7/8" 124 (4035), Exterior Bar Type = PVC (Stock PVC Profiles), Exterior Grille Profile = CGR-7/8" 124 (4035), SDL Tape Color = Gray, 1W2H

- Ratings -

Performance Rating = Standard

- Threshold -

LineItem #	Unit Details	Quantity
------------	--------------	----------

300-1		2
WindowAndDoor		
Comment/Room:	2nd Floor - Unit is Curved Frame, Sash, and Glass Radius= 105"	
	Overall Frame: 47.5" X 88.5"	
	Overall RO: 48.5" X 89"	

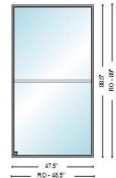

Wood Direct Sets

Frame Width = 47.5, Frame Height = 88.5

Unit Type = Complete Unit, Unit Profile = Standard

- Frame -  
3/4" x 4 9/16" Pine ,Unit Finishing (Exterior Is Poly Painted In PL - White ,Interior Is Ultra Primed). B13 Exterior Stops ,B13 Interior Stops.

- Casing Options -

No Brickmold/Casing, No Subsill, Masonry Clips = 7.5" Masonry Clip, Applied

- Glass -

1" Insulated IGU Curved Pilkington LowE with Argon Gas Tempered with Black (Aluminum) spacer.

- Grilles -

Simulated Divided Lite w/o Internal Spacer, Rectangular, Match Unit Materials & Finishes = Yes, Interior Bar Type = PVC, Interior Wood Grille Profile = CGR-7/8" 124 (4035), Exterior Bar Type = PVC (Stock PVC Profiles), Exterior Grille Profile = CGR-7/8" 124 (4035), SDL Tape Color = Gray, 1W2H

- Ratings -

Performance Rating = Standard

- Threshold -



Curved Glass "Simulated Hung" Fixed Units

Customer Comments:

LineItem #	Unit Details	Quantity
400-1		4
WindowAndDoor		
Comment/Room:	3rd Floor - Unit is Curved Frame, Sash, and Glass Radius= 105"	
	Overall Frame: 47.5" X 80.75"	
	Overall RO: 48.5" X 81.25"	

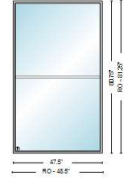

Wood Direct Sets

Frame Width = 47.5, Frame Height = 80.75

Unit Type = Complete Unit, Unit Profile = Standard

- Frame -
- 3/4" x 4 9/16" Pine ,Unit Finishing (Exterior Is Poly Painted In PL - White ,Interior Is Ultra Primed). B13 Exterior Stops ,B13 Interior Stops.
- Casing Options -
- No Brickmold/Casing, No Subsill, Masonry Clips = 7.5" Masonry Clip, Applied
- Glass -
- 1" Insulated IGU Curved Pilkington LowE with Argon Gas Tempered with Black (Aluminum) spacer.
- Grilles -
- Simulated Divided Lite w/o Internal Spacer, Rectangular, Match Unit Materials & Finishes = Yes, Interior Bar Type = PVC, Interior Wood Grille Profile = CGR-7/8" 124 (4035), Exterior Bar Type = PVC (Stock PVC Profiles), Exterior Grille Profile = CGR-7/8" 124 (4035), SDL Tape Color = Gray, 1W2H
- Ratings -
- Performance Rating = Standard
- Threshold -

LineItem #	Unit Details	Quantity
500-1		4
WindowAndDoor		
Comment/Room:	4th Floor - Unit is Curved Frame, Sash, and Glass Radius= 105"	
	Overall Frame: 47.5" X 76.5"	
	Overall RO: 48.5" X 77"	

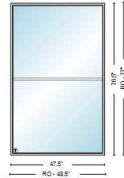

Wood Direct Sets

Frame Width = 47.5, Frame Height = 76.5

Unit Type = Complete Unit, Unit Profile = Standard

- Frame -
- 3/4" x 4 9/16" Pine ,Unit Finishing (Exterior Is Poly Painted In PL - White ,Interior Is Ultra Primed). B13 Exterior Stops ,B13 Interior Stops.
- Casing Options -
- No Brickmold/Casing, No Subsill, Masonry Clips = 7.5" Masonry Clip, Applied
- Glass -
- 1" Insulated IGU Curved Pilkington LowE with Argon Gas Tempered with Black (Aluminum) spacer.
- Grilles -
- Simulated Divided Lite w/o Internal Spacer, Rectangular, Match Unit Materials & Finishes = Yes, Interior Bar Type = PVC, Interior Wood Grille Profile = CGR-7/8" 124 (4035), Exterior Bar Type = PVC (Stock PVC Profiles), Exterior Grille Profile = CGR-7/8" 124 (4035), SDL Tape Color = Gray, 1W2H
- Ratings -
- Performance Rating = Standard
- Threshold -

DATE:					
REV:	△	△	△	△	△
DATE:					
REV:	△	△	△	△	△

INSTALLATION SHOP DRAWING FOR  
LOCATION: DEADWOOD, SOUTH DAKOTA  
ARCHITECT: -

ORIGINAL: 07-19-2021  
DRAWN BY: BMB  
CHECKED BY: JPV  
Project No.:  
**228261.01**  
SHEET:  
**05 OF 05**

**DETAIL KEYNOTES**

**BC :** BUILDING COMPONENTS (BY OTHERS)

BC05.02 LEVEL OPENING SILL PRIOR TO UNIT INSTALLATION. PROVIDE IMPERVIOUS SHIMS 1/2" FROM EACH OPENING JAMB AND AT WINDOW MULLION AS REQUIRED. FOR VINYL WINDOWS, ADD SHIMS SO MAXIMUM SPACING IS 18".

BC05.10 SHIM AS REQUIRED AT ANCHORAGE LOCATIONS. (DO NOT OVER SHIM)

**FC :** FASTENING COMPONENTS

FC01.27 PRE-DRILL PILOT HOLES AND ANCHOR UNIT TO OPENING WITH #8 x 3 1/8" FINISH HEAD WOOD SCREWS SPACED WITHIN 6" OF OUTSIDE EDGE AND 16" ON CENTER MAXIMUM. CAUTION: SHIM AT ANCHORAGE LOCATIONS. DO NOT BOW WINDOW FRAME.

**TM :** THERMAL AND MOISTURE PROTECTION

TM03.01 WATER RESISTANT BACKER ROD AND SEALANT.

**CC1**

TYPICAL SPACING OF FRAME SCREWS AT FRAME AND SILL

Refer to the Special Notes

No anchors required at sill  
Monumental Double Hung

Anchor Through Frame Spacing				Special Notes
Product	Edge Spacing (E)	Max. Intermediate Spacing (S)	Fastener	
Double- or Single-Hung	6"	16"	#8 X 3" Finish Screw	Remove sashes and jamb liners. Drive 1 screw through each jamb liner support clip (top, bottom, checkrail and center of each sash). Drive 2 additional screws through the frame (or secure clips) 3" above and below the checkrail on each jamb. Drive additional screws through the frame (or secure clips) centered between each jamb liner support clip.
Monumental DH <math>\ge 54" \times 96" </math>	6" (Head)	16" (Head)	#8 x 3" Screw	

\* For light gauge steel framing, use #10 self-drilling/self-tapping screws. For concrete or masonry, use 3/16" masonry screws with 1-1/4" min. embedment.

**CLAD ANCHOR THROUGH FRAME INSTALLATION**  
TYPICAL DETAILS APPLY UNLESS OTHERWISE SPECIFIED

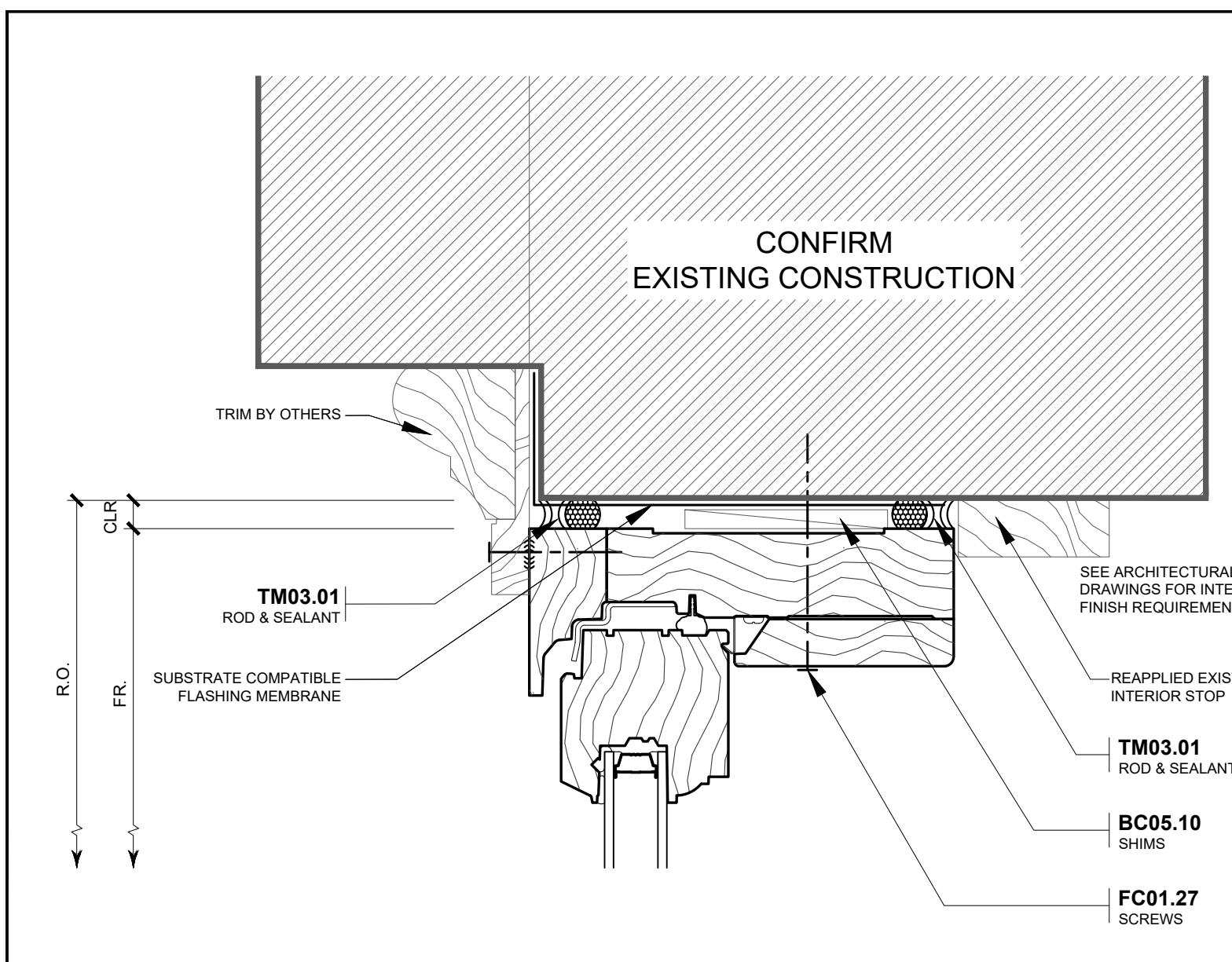

**1 HEAD**  
REF. ARCH. DWG. -

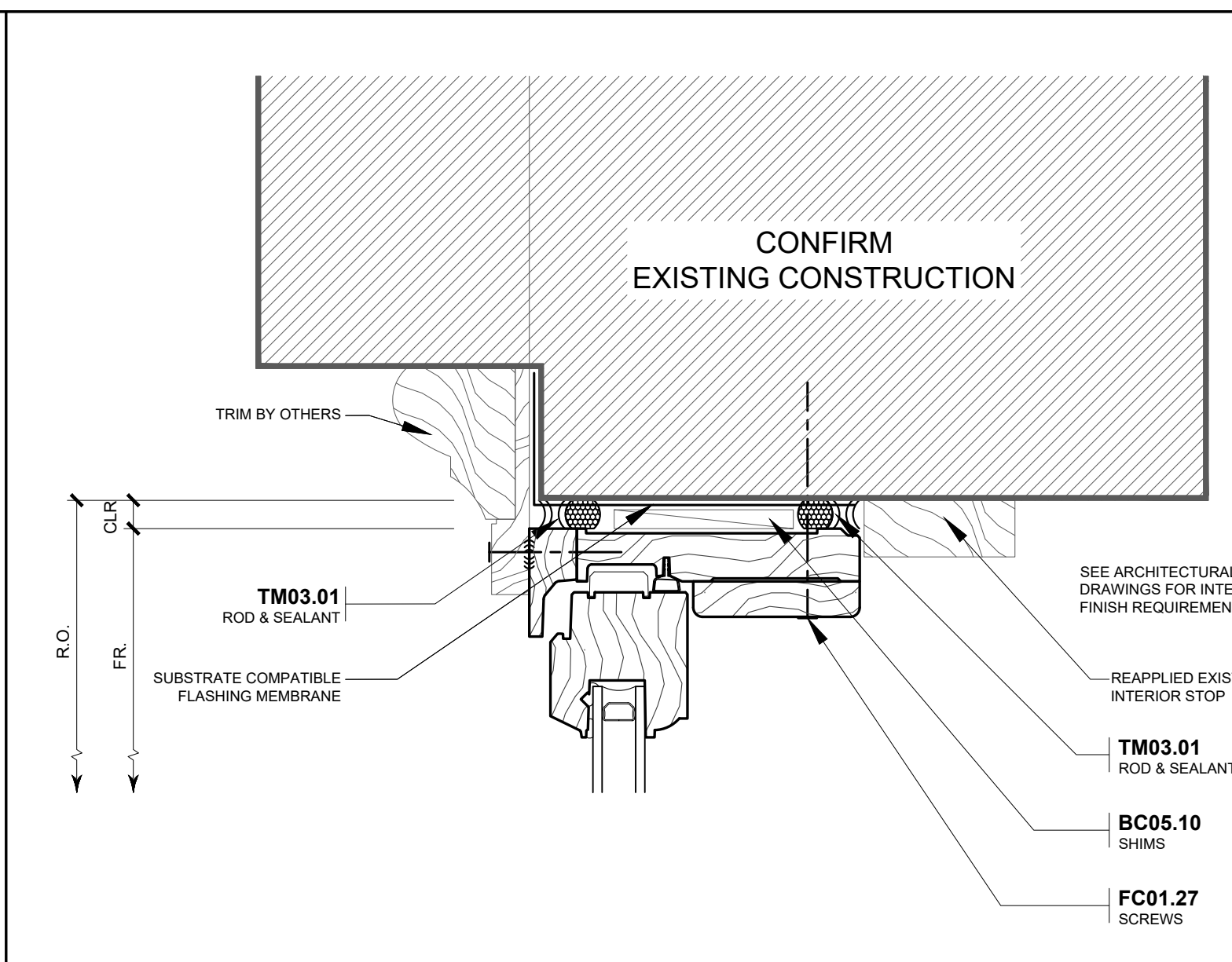

**4 HEAD**  
REF. ARCH. DWG. -

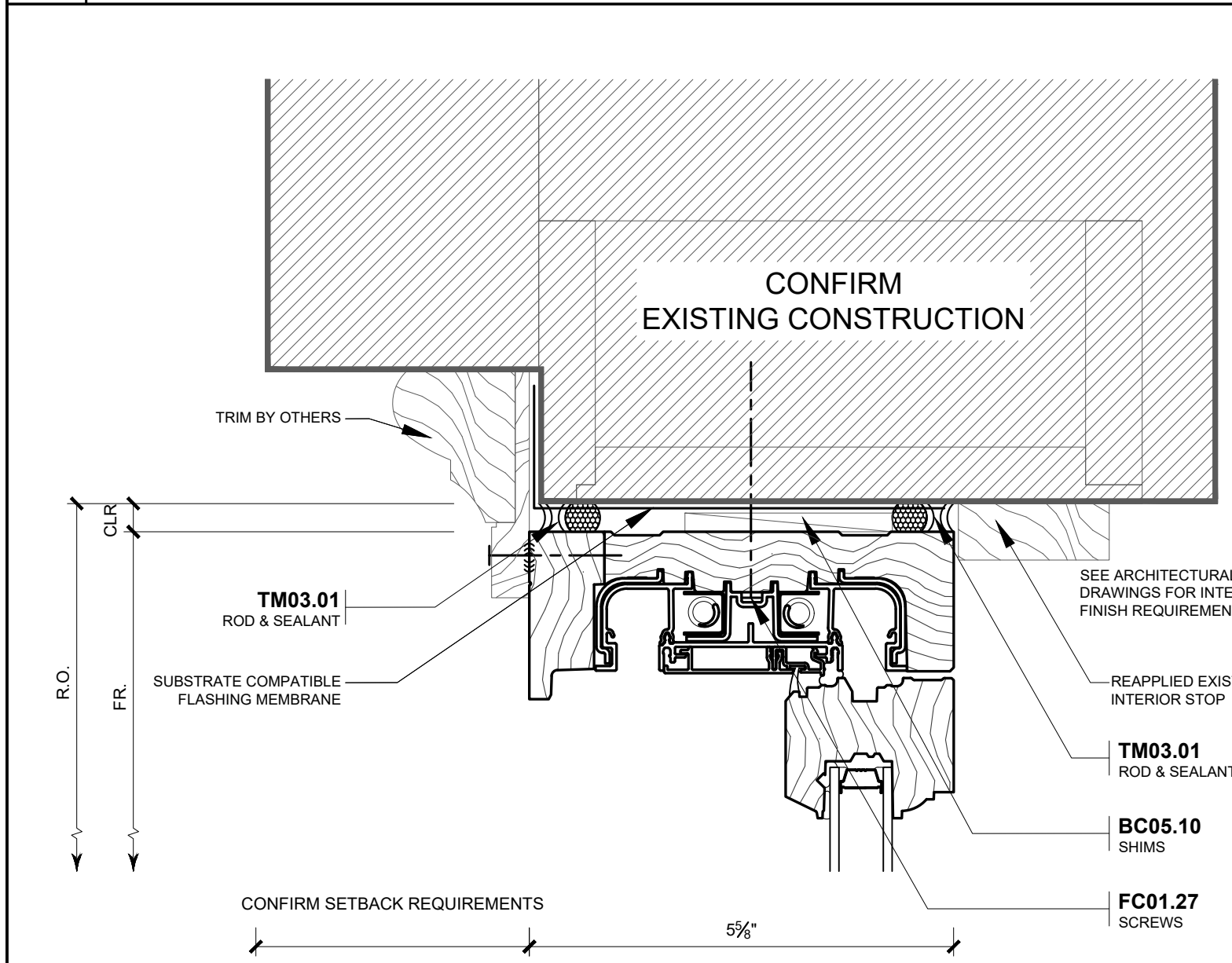

**2 JAMB**  
REF. ARCH. DWG. -

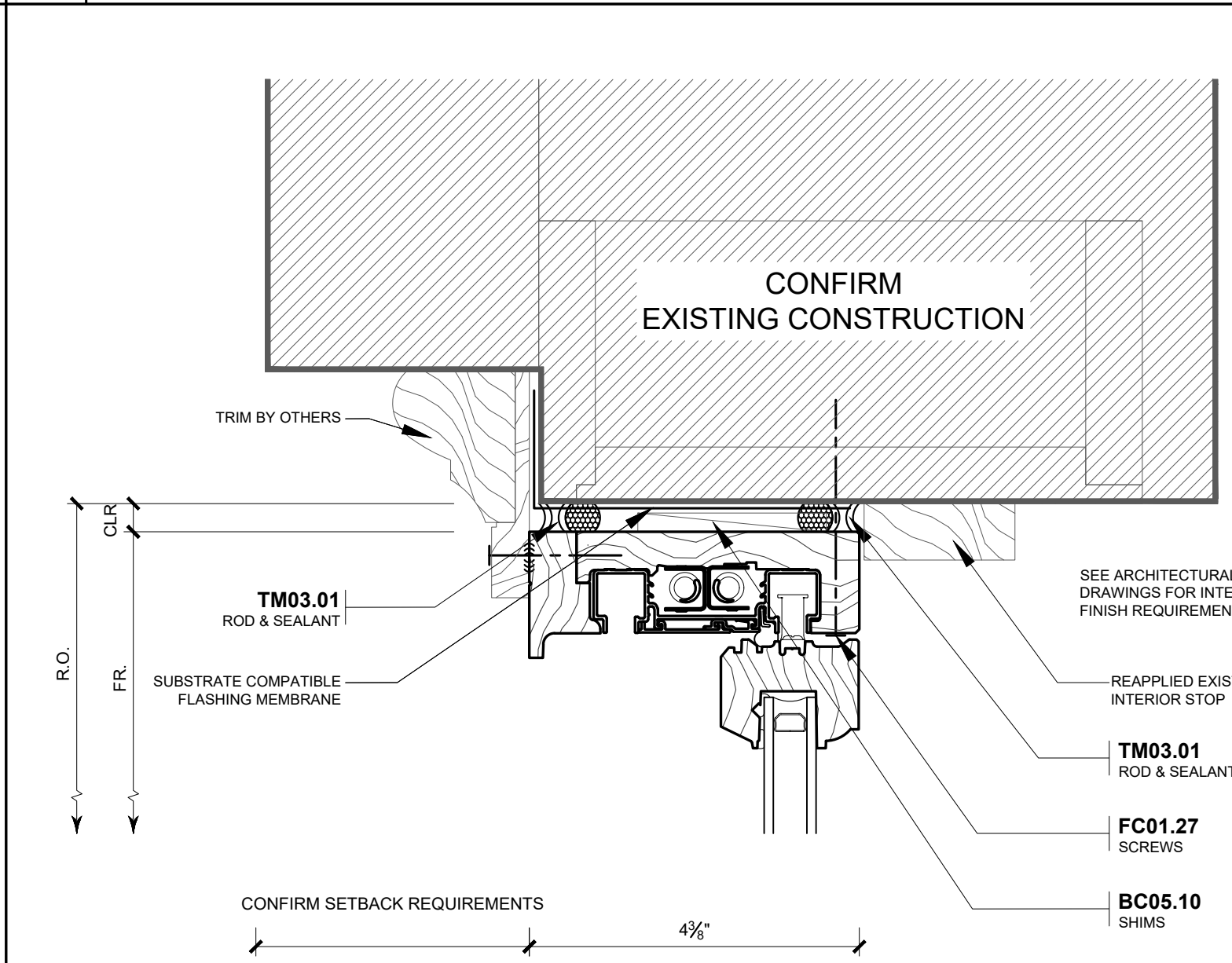

**5 JAMB**  
REF. ARCH. DWG. -

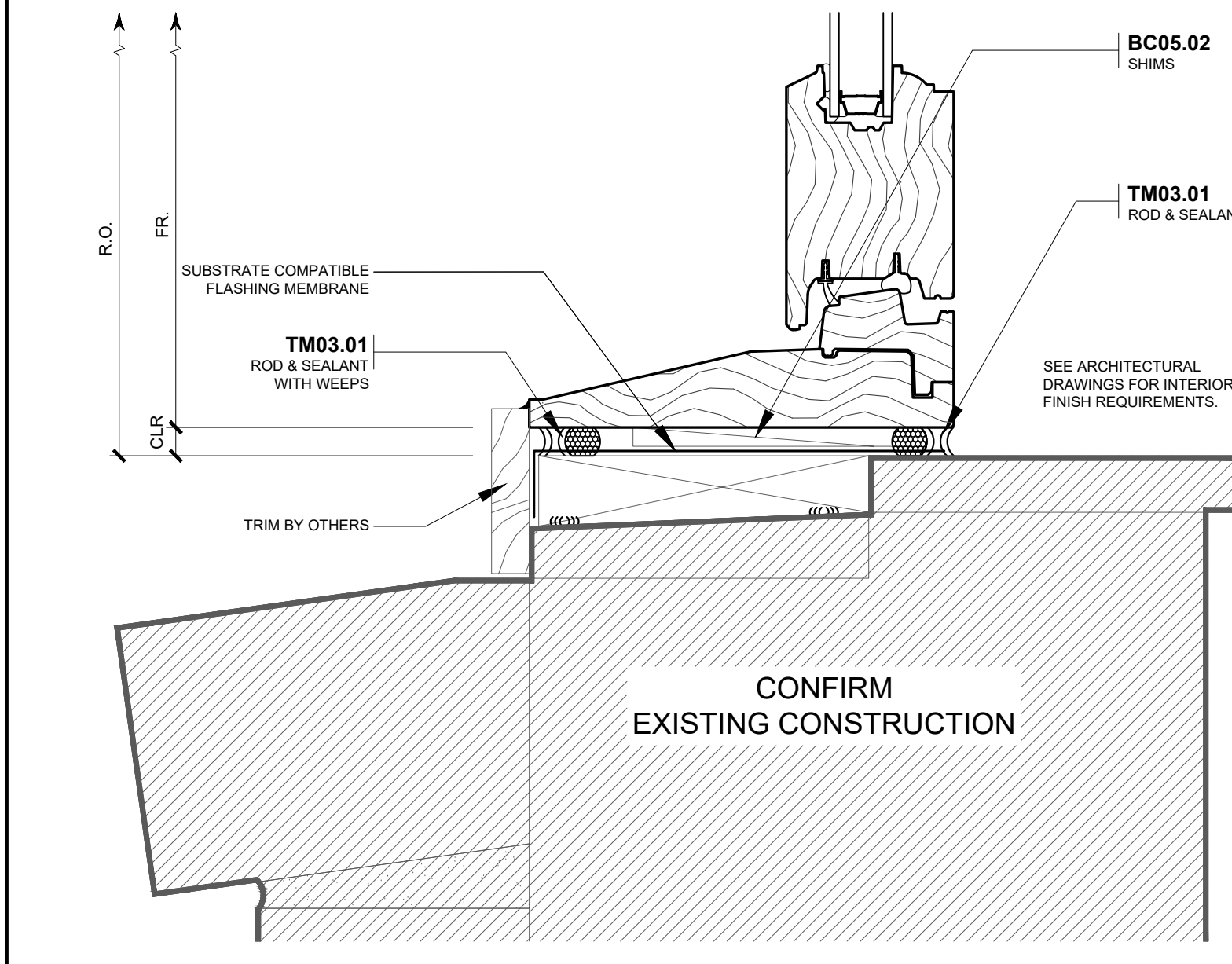

**3 SILL**  
REF. ARCH. DWG. -

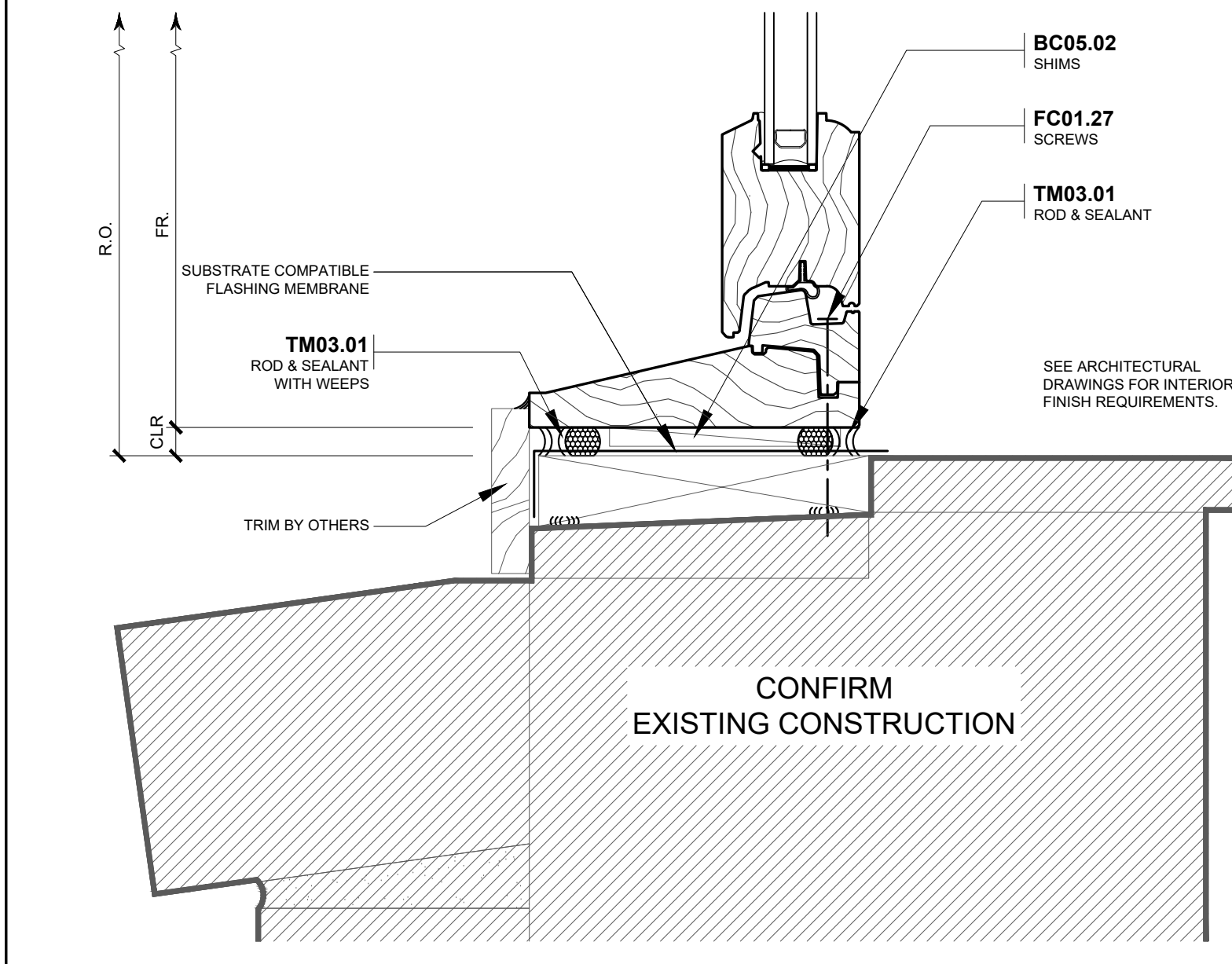

**6 SILL**  
REF. ARCH. DWG. -

# Customer Approval Form:

Signature: \_\_\_\_\_ Date: \_\_\_\_\_

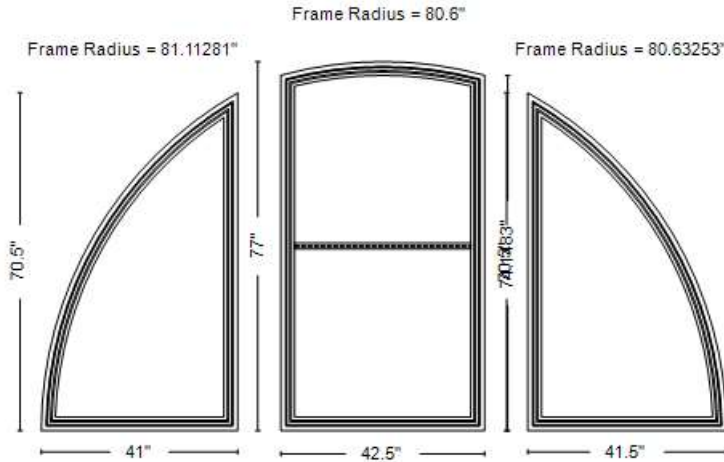

Viewed from the Exterior

Quote Number: 17978288

Line Number: 10

Quote Qty: 1

Scaling: 1/2" = 1'

Description: Pella® Reserve, , Traditional Sash Set, Sash Set, Sash Set, 143 X 77

Rough Opening: 42.25" X 71.5"

Performance Information: U-Factor 0.26, SHGC 0.30, VLT 0.56, CPD PEL-N-41-43856-00001, Performance Class CW, PG 40, Calculated Positive DP Rating 40, Calculated Negative DP Rating 40, Year Rated 11

Performance Information: U-Factor 0.29, SHGC 0.24, VLT 0.44, CPD PEL-N-41-43923-00001, Performance Class CW, PG 40, Calculated Positive DP Rating 40, Calculated Negative DP Rating 40, Year Rated 11

Performance Information: U-Factor 0.26, SHGC 0.30, VLT 0.56, CPD PEL-N-41-43856-00001, Performance Class CW, PG 40, Calculated Positive DP Rating 40, Calculated Negative DP Rating 40, Year Rated 11

These drawings are based on our interpretation of the information provided to us. They are submitted for final approval of the individual\*\* responsible for the project and are not intended to create any warranty or other liability. The user\*\* is responsible for compliance with applicable building codes or other regulations and determining the suitability of the suggestions for the particular application, including the final design of reinforcement, flashing, and sealant systems for all window and door installations.  
 \*\* building owner, architect, contractor, installer and/or consumer



Quote Name: Franklin Hotel Remodel - Reserve Project Name: A1 Construction - Franklin

Jobsite Location: RAPID CITY, SD

Room Location: 4F B&R ARCH FIXED

Sales Branch Location: 23300 Heartland Pella

# Customer Approval Form:

Signature: \_\_\_\_\_ Date: \_\_\_\_\_

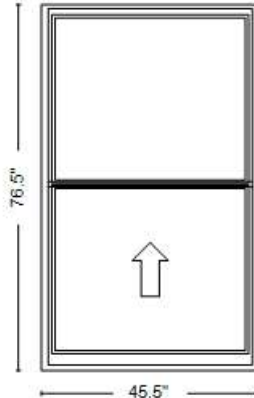

Viewed from the Exterior

Quote Number: 17978288

Line Number: 20

Quote Qty: 28

Scaling: 1/2" = 1'

Description: Pella® Reserve, , Traditional Single Hung, 45.5 X 76.5

Rough Opening: 46.25" X 77.25"

Performance Information: U-Factor 0.28, SHGC 0.28, VLT 0.53, CPD PEL-N-234-01141-00001, Performance Class CW, PG 45, Calculated Positive DP Rating 45, Calculated Negative DP Rating 45, Year Rated 08|11, Clear Opening Width 42.125, Clear Opening Height 33.812, Clear Opening Area 9.891184, Egress Meets Typical 5.7 sqft (E) (United States Only)

These drawings are based on our interpretation of the information provided to us. They are submitted for final approval of the individual\*\* responsible for the project and are not intended to create any warranty or other liability. The user\*\* is responsible for compliance with applicable building codes or other regulations and determining the suitability of the suggestions for the particular application, including the final design of reinforcement, flashing, and sealant systems for all window and door installations.  
\*\* building owner, architect, contractor, installer and/or consumer



Quote Name: Franklin Hotel Remodel - Reserve Project Name: A1 Construction - Franklin

Jobsite Location: RAPID CITY, SD

Room Location: 4F W1

Sales Branch Location: 23300 Heartland Pella

# Customer Approval Form:

Signature: \_\_\_\_\_ Date: \_\_\_\_\_

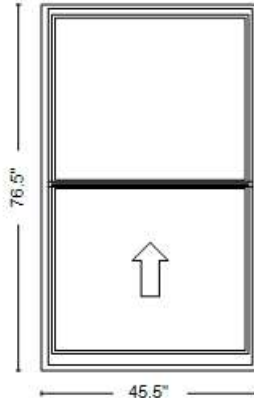

Viewed from the Exterior

Quote Number: 17978288

Line Number: 25

Quote Qty: 1

Scaling: 1/2" = 1'

Description: Pella® Reserve, , Traditional Single Hung, 45.5 X 76.5

Rough Opening: 46.25" X 77.25"

Performance Information: U-Factor 0.28, SHGC 0.28, VLT 0.52, CPD PEL-N-234-01145-00001, Performance Class CW, PG 45, Calculated Positive DP Rating 45, Calculated Negative DP Rating 45, Year Rated 08|11, Clear Opening Width 42.125, Clear Opening Height 33.812, Clear Opening Area 9.891184, Egress Meets Typical 5.7 sqft (E) (United States Only)

These drawings are based on our interpretation of the information provided to us. They are submitted for final approval of the individual\*\* responsible for the project and are not intended to create any warranty or other liability. The user\*\* is responsible for compliance with applicable building codes or other regulations and determining the suitability of the suggestions for the particular application, including the final design of reinforcement, flashing, and sealant systems for all window and door installations.  
\*\* building owner, architect, contractor, installer and/or consumer



Quote Name: Franklin Hotel Remodel - Reserve Project Name: A1 Construction - Franklin

Jobsite Location: RAPID CITY, SD

Room Location: 4F W1 - 411 BR

Sales Branch Location: 23300 Heartland Pella

# Customer Approval Form:

Signature: \_\_\_\_\_ Date: \_\_\_\_\_

04

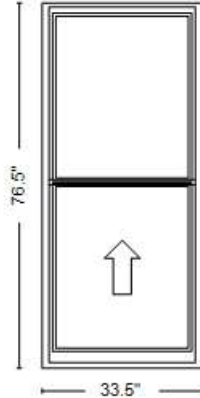

Viewed from the Exterior

Quote Number: 17978288

Line Number: 30

Quote Qty: 6

Scaling: 1/2" = 1'

Description: Pella® Reserve, , Traditional Single Hung, 33.5 X 76.5

Rough Opening: 34.25" X 77.25"

Performance Information: U-Factor 0.28, SHGC 0.28, VLT 0.53, CPD PEL-N-234-01141-00001, Performance Class CW, PG 45, Calculated Positive DP Rating 45, Calculated Negative DP Rating 45, Year Rated 08|11, Clear Opening Width 30.125, Clear Opening Height 33.812, Clear Opening Area 7.073517, Egress Meets Typical 5.7 sqft (E) (United States Only)

These drawings are based on our interpretation of the information provided to us. They are submitted for final approval of the individual\*\* responsible for the project and are not intended to create any warranty or other liability. The user\*\* is responsible for compliance with applicable building codes or other regulations and determining the suitability of the suggestions for the particular application, including the final design of reinforcement, flashing, and sealant systems for all window and door installations.  
\*\* building owner, architect, contractor, installer and/or consumer



Quote Name: Franklin Hotel Remodel - Reserve Project Name: A1 Construction - Franklin

Jobsite Location: RAPID CITY, SD

Room Location: 4F W2

Sales Branch Location: 23300 Heartland Pella

# Customer Approval Form:

Signature: \_\_\_\_\_ Date: \_\_\_\_\_

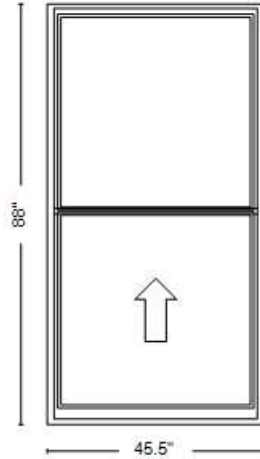

Viewed from the Exterior

Quote Number: 17978288

Line Number: 35

Quote Qty: 12

Scaling: 1/2" = 1'

Description: Pella® Reserve, , Traditional Single Hung, 45.5 X 88

Rough Opening: 46.25" X 88.75"

Performance Information: U-Factor 0.28, SHGC 0.28, VLT 0.52, CPD PEL-N-234-01145-00001, Performance Class CW, PG 30, Calculated Positive DP Rating 30, Calculated Negative DP Rating 30, Year Rated 08|11, Clear Opening Width 42.125, Clear Opening Height 39.562, Clear Opening Area 11.57326, Egress Meets Typical 5.7 sqft (E) (United States Only)

These drawings are based on our interpretation of the information provided to us. They are submitted for final approval of the individual\*\* responsible for the project and are not intended to create any warranty or other liability. The user\*\* is responsible for compliance with applicable building codes or other regulations and determining the suitability of the suggestions for the particular application, including the final design of reinforcement, flashing, and sealant systems for all window and door installations.  
\*\* building owner, architect, contractor, installer and/or consumer



Quote Name: Franklin Hotel Remodel - Reserve Project Name: A1 Construction - Franklin

Jobsite Location: RAPID CITY, SD

Room Location: 4F W3

Sales Branch Location: 23300 Heartland Pella

# Customer Approval Form:

Signature: \_\_\_\_\_ Date: \_\_\_\_\_

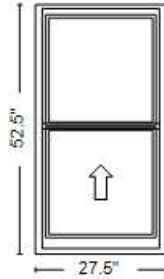

Viewed from the Exterior

Quote Number: 17978288

Line Number: 40

Quote Qty: 1

Scaling: 1/2" = 1'

Description: Pella® Reserve, , Traditional Single Hung, 27.5 X 52.5

Rough Opening: 28.25" X 53.25"

Performance Information: U-Factor 0.28, SHGC 0.28, VLT 0.52, CPD PEL-N-234-01145-00001, Performance Class CW, PG 45, Calculated Positive DP Rating 45, Calculated Negative DP Rating 45, Year Rated 08|11, Clear Opening Width 24.125, Clear Opening Height 21.812, Clear Opening Area 3.654267, Egress Does not meet typical United States egress, but may comply with local code requirements

These drawings are based on our interpretation of the information provided to us. They are submitted for final approval of the individual\*\* responsible for the project and are not intended to create any warranty or other liability. The user\*\* is responsible for compliance with applicable building codes or other regulations and determining the suitability of the suggestions for the particular application, including the final design of reinforcement, flashing, and sealant systems for all window and door installations.  
\*\* building owner, architect, contractor, installer and/or consumer



Quote Name: Franklin Hotel Remodel - Reserve Project Name: A1 Construction - Franklin

Jobsite Location: RAPID CITY, SD

Room Location: 4F W4 - 405 BR

Sales Branch Location: 23300 Heartland Pella



# Customer Approval Form:

Signature: \_\_\_\_\_ Date: \_\_\_\_\_

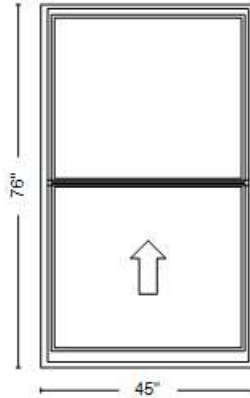

Viewed from the Exterior

Quote Number: 17978288

Line Number: 41

Quote Qty: 1

Scaling: 1/2" = 1'

Description: Pella® Reserve, , Traditional Single Hung, 45 X 76

Rough Opening: 45.75" X 76.75"

Performance Information: U-Factor 0.28, SHGC 0.28, VLT 0.53, CPD PEL-N-234-01141-00001, Performance Class CW, PG 45, Calculated Positive DP Rating 45, Calculated Negative DP Rating 45, Year Rated 08|11, Clear Opening Width 41.625, Clear Opening Height 33.562, Clear Opening Area 9.701516, Egress Meets Typical 5.7 sqft (E) (United States Only)

These drawings are based on our interpretation of the information provided to us. They are submitted for final approval of the individual\*\* responsible for the project and are not intended to create any warranty or other liability. The user\*\* is responsible for compliance with applicable building codes or other regulations and determining the suitability of the suggestions for the particular application, including the final design of reinforcement, flashing, and sealant systems for all window and door installations.  
\*\* building owner, architect, contractor, installer and/or consumer



Quote Name: Franklin Hotel Remodel - Reserve Project Name: A1 Construction - Franklin

Jobsite Location: RAPID CITY, SD

Room Location: 4F W5

Sales Branch Location: 23300 Heartland Pella

# Customer Approval Form:

Signature: \_\_\_\_\_ Date: \_\_\_\_\_

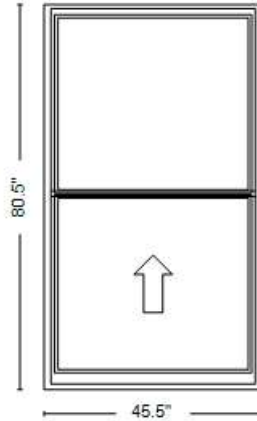

Viewed from the Exterior

Quote Number: 17978288

Line Number: 45

Quote Qty: 31

Scaling: 1/2" = 1'

Description: Pella® Reserve, , Traditional Single Hung, 45.5 X 80.5

Rough Opening: 46.25" X 81.25"

Performance Information: U-Factor 0.28, SHGC 0.28, VLT 0.53, CPD PEL-N-234-01141-00001, Performance Class CW, PG 40, Calculated Positive DP Rating 40, Calculated Negative DP Rating 40, Year Rated 08|11, Clear Opening Width 42.125, Clear Opening Height 35.812, Clear Opening Area 10.47625, Egress Meets Typical 5.7 sqft (E) (United States Only)

These drawings are based on our interpretation of the information provided to us. They are submitted for final approval of the individual\*\* responsible for the project and are not intended to create any warranty or other liability. The user\*\* is responsible for compliance with applicable building codes or other regulations and determining the suitability of the suggestions for the particular application, including the final design of reinforcement, flashing, and sealant systems for all window and door installations.  
\*\* building owner, architect, contractor, installer and/or consumer



Quote Name: Franklin Hotel Remodel - Reserve Project Name: A1 Construction - Franklin

Jobsite Location: RAPID CITY, SD

Room Location: 3F W1

Sales Branch Location: 23300 Heartland Pella

# Customer Approval Form:

Signature: \_\_\_\_\_ Date: \_\_\_\_\_

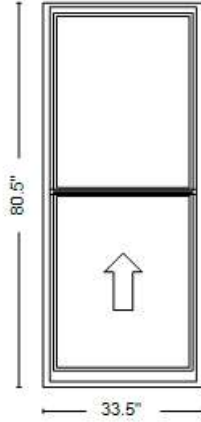

Viewed from the Exterior

Quote Number: 17978288

Line Number: 50

Quote Qty: 4

Scaling: 1/2" = 1'

Description: Pella® Reserve, , Traditional Single Hung, 33.5 X 80.5

Rough Opening: 34.25" X 81.25"

Performance Information: U-Factor 0.28, SHGC 0.28, VLT 0.53, CPD PEL-N-234-01141-00001, Performance Class CW, PG 40, Calculated Positive DP Rating 40, Calculated Negative DP Rating 40, Year Rated 08|11, Clear Opening Width 30.125, Clear Opening Height 35.812, Clear Opening Area 7.49192, Egress Meets Typical 5.7 sqft (E) (United States Only)

These drawings are based on our interpretation of the information provided to us. They are submitted for final approval of the individual\*\* responsible for the project and are not intended to create any warranty or other liability. The user\*\* is responsible for compliance with applicable building codes or other regulations and determining the suitability of the suggestions for the particular application, including the final design of reinforcement, flashing, and sealant systems for all window and door installations.  
\*\* building owner, architect, contractor, installer and/or consumer



Quote Name: Franklin Hotel Remodel - Reserve Project Name: A1 Construction - Franklin

Jobsite Location: RAPID CITY, SD

Room Location: 3F W2

Sales Branch Location: 23300 Heartland Pella

# Customer Approval Form:

Signature: \_\_\_\_\_ Date: \_\_\_\_\_

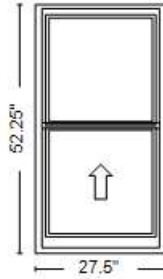

Viewed from the Exterior

Quote Number: 17978288

Line Number: 55

Quote Qty: 1

Scaling: 1/2" = 1'

Description: Pella® Reserve, , Traditional Single Hung, 27.5 X 52.25

Rough Opening: 28.25" X 53"

Performance Information: U-Factor 0.28, SHGC 0.28, VLT 0.52, CPD PEL-N-234-01145-00001, Performance Class CW, PG 45, Calculated Positive DP Rating 45, Calculated Negative DP Rating 45, Year Rated 08|11, Clear Opening Width 24.125, Clear Opening Height 21.687, Clear Opening Area 3.633326, Egress Does not meet typical United States egress, but may comply with local code requirements

These drawings are based on our interpretation of the information provided to us. They are submitted for final approval of the individual\*\* responsible for the project and are not intended to create any warranty or other liability. The user\*\* is responsible for compliance with applicable building codes or other regulations and determining the suitability of the suggestions for the particular application, including the final design of reinforcement, flashing, and sealant systems for all window and door installations.  
\*\* building owner, architect, contractor, installer and/or consumer



Quote Name: Franklin Hotel Remodel - Reserve Project Name: A1 Construction - Franklin

Jobsite Location: RAPID CITY, SD

Room Location: 3F W3 - 305 BR

Sales Branch Location: 23300 Heartland Pella

# Customer Approval Form:

Signature: \_\_\_\_\_ Date: \_\_\_\_\_

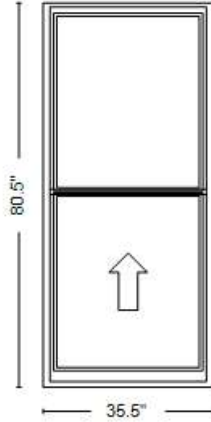

Viewed from the Exterior

Quote Number: 17978288

Line Number: 60

Quote Qty: 2

Scaling: 1/2" = 1'

Description: Pella® Reserve, , Traditional Single Hung, 35.5 X 80.5

Rough Opening: 36.25" X 81.25"

Performance Information: U-Factor 0.28, SHGC 0.28, VLT 0.53, CPD PEL-N-234-01141-00001, Performance Class CW, PG 40, Calculated Positive DP Rating 40, Calculated Negative DP Rating 40, Year Rated 08|11, Clear Opening Width 32.125, Clear Opening Height 35.812, Clear Opening Area 7.989309, Egress Meets Typical 5.7 sqft (E) (United States Only)

These drawings are based on our interpretation of the information provided to us. They are submitted for final approval of the individual\*\* responsible for the project and are not intended to create any warranty or other liability. The user\*\* is responsible for compliance with applicable building codes or other regulations and determining the suitability of the suggestions for the particular application, including the final design of reinforcement, flashing, and sealant systems for all window and door installations.  
\*\* building owner, architect, contractor, installer and/or consumer



Quote Name: Franklin Hotel Remodel - Reserve Project Name: A1 Construction - Franklin

Jobsite Location: RAPID CITY, SD

Room Location: 3F W4

Sales Branch Location: 23300 Heartland Pella

# Customer Approval Form:

Signature: \_\_\_\_\_ Date: \_\_\_\_\_

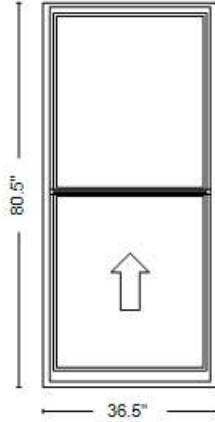

Viewed from the Exterior

Quote Number: 17978288

Line Number: 65

Quote Qty: 1

Scaling: 1/2" = 1'

Description: Pella® Reserve, , Traditional Single Hung, 36.5 X 80.5

Rough Opening: 37.25" X 81.25"

Performance Information: U-Factor 0.28, SHGC 0.28, VLT 0.53, CPD PEL-N-234-01141-00001, Performance Class CW, PG 40, Calculated Positive DP Rating 40, Calculated Negative DP Rating 40, Year Rated 08|11, Clear Opening Width 33.125, Clear Opening Height 35.812, Clear Opening Area 8.238004, Egress Meets Typical 5.7 sqft (E) (United States Only)

These drawings are based on our interpretation of the information provided to us. They are submitted for final approval of the individual\*\* responsible for the project and are not intended to create any warranty or other liability. The user\*\* is responsible for compliance with applicable building codes or other regulations and determining the suitability of the suggestions for the particular application, including the final design of reinforcement, flashing, and sealant systems for all window and door installations.  
\*\* building owner, architect, contractor, installer and/or consumer



Quote Name: Franklin Hotel Remodel - Reserv Project Name: A1 Construction - Franklin

Jobsite Location: RAPID CITY, SD

Room Location: 3F W5

Sales Branch Location: 23300 Heartland Pella

# Customer Approval Form:

Signature: \_\_\_\_\_ Date: \_\_\_\_\_

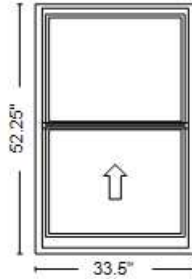

Viewed from the Exterior

Quote Number: 17978288

Line Number: 70

Quote Qty: 1

Scaling: 1/2" = 1'

Description: Pella® Reserve, , Traditional Single Hung, 33.5 X 52.25

Rough Opening: 34.25" X 53"

Performance Information: U-Factor 0.28, SHGC 0.28, VLT 0.53, CPD PEL-N-234-01141-00001, Performance Class CW, PG 45, Calculated Positive DP Rating 45, Calculated Negative DP Rating 45, Year Rated 08|11, Clear Opening Width 30.125, Clear Opening Height 21.687, Clear Opening Area 4.536951, Egress Does not meet typical United States egress, but may comply with local code requirements

These drawings are based on our interpretation of the information provided to us. They are submitted for final approval of the individual\*\* responsible for the project and are not intended to create any warranty or other liability. The user\*\* is responsible for compliance with applicable building codes or other regulations and determining the suitability of the suggestions for the particular application, including the final design of reinforcement, flashing, and sealant systems for all window and door installations.  
\*\* building owner, architect, contractor, installer and/or consumer



Quote Name: Franklin Hotel Remodel - Reserve Project Name: A1 Construction - Franklin

Jobsite Location: RAPID CITY, SD

Room Location: 3F W6

Sales Branch Location: 23300 Heartland Pella

# Customer Approval Form:

Signature: \_\_\_\_\_ Date: \_\_\_\_\_

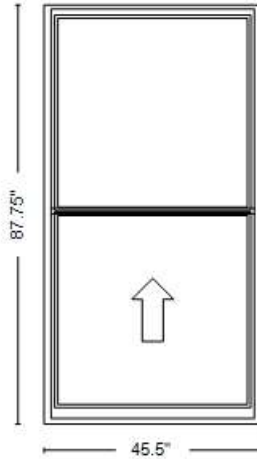

Viewed from the Exterior

Quote Number: 17978288

Line Number: 75

Quote Qty: 12

Scaling: 1/2" = 1'

Description: Pella® Reserve, , Traditional Single Hung, 45.5 X 87.75

Rough Opening: 46.25" X 88.5"

Performance Information: U-Factor 0.28, SHGC 0.28, VLT 0.52, CPD PEL-N-234-01145-00001, Performance Class CW, PG 30, Calculated Positive DP Rating 30, Calculated Negative DP Rating 30, Year Rated 08|11, Clear Opening Width 42.125, Clear Opening Height 39.437, Clear Opening Area 11.53669, Egress Meets Typical 5.7 sqft (E) (United States Only)

These drawings are based on our interpretation of the information provided to us. They are submitted for final approval of the individual\*\* responsible for the project and are not intended to create any warranty or other liability. The user\*\* is responsible for compliance with applicable building codes or other regulations and determining the suitability of the suggestions for the particular application, including the final design of reinforcement, flashing, and sealant systems for all window and door installations.  
\*\* building owner, architect, contractor, installer and/or consumer



Quote Name: Franklin Hotel Remodel - Reserv Project Name: A1 Construction - Franklin

Jobsite Location: RAPID CITY, SD

Room Location: 3F W7

Sales Branch Location: 23300 Heartland Pella



# Customer Approval Form:

Signature: \_\_\_\_\_ Date: \_\_\_\_\_

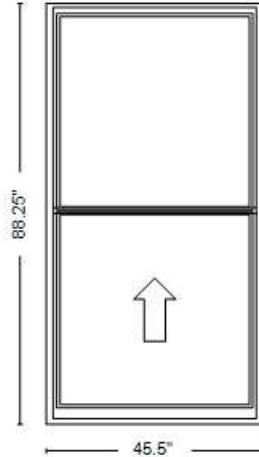

Viewed from the Exterior

Quote Number: 17978288

Line Number: 80

Quote Qty: 29

Scaling: 1/2" = 1'

Description: Pella® Reserve, , Traditional Single Hung, 45.5 X 88.25

Rough Opening: 46.25" X 89"

Performance Information: U-Factor 0.28, SHGC 0.28, VLT 0.52, CPD PEL-N-234-01145-00001, Performance Class CW, PG 30, Calculated Positive DP Rating 30, Calculated Negative DP Rating 30, Year Rated 08|11, Clear Opening Width 42.125, Clear Opening Height 39.687, Clear Opening Area 11.60983, Egress Meets Typical 5.7 sqft (E) (United States Only)

These drawings are based on our interpretation of the information provided to us. They are submitted for final approval of the individual\*\* responsible for the project and are not intended to create any warranty or other liability. The user\*\* is responsible for compliance with applicable building codes or other regulations and determining the suitability of the suggestions for the particular application, including the final design of reinforcement, flashing, and sealant systems for all window and door installations.  
\*\* building owner, architect, contractor, installer and/or consumer



Quote Name: Franklin Hotel Remodel - Reserv Project Name: A1 Construction - Franklin

Jobsite Location: RAPID CITY, SD

Room Location: 2F W1

Sales Branch Location: 23300 Heartland Pella

# Customer Approval Form:

Signature: \_\_\_\_\_ Date: \_\_\_\_\_

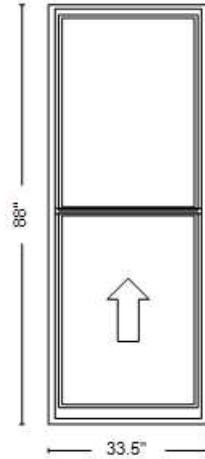

Viewed from the Exterior

Quote Number: 17978288

Line Number: 85

Quote Qty: 1

Scaling: 1/2" = 1'

Description: Pella® Reserve, , Traditional Single Hung, 33.5 X 88

Rough Opening: 34.25" X 88.75"

Performance Information: U-Factor 0.28, SHGC 0.28, VLT 0.53, CPD PEL-N-234-01141-00001, Performance Class CW, PG 30, Calculated Positive DP Rating 30, Calculated Negative DP Rating 30, Year Rated 08|11, Clear Opening Width 30.125, Clear Opening Height 39.562, Clear Opening Area 8.276425, Egress Meets Typical 5.7 sqft (E) (United States Only)

These drawings are based on our interpretation of the information provided to us. They are submitted for final approval of the individual\*\* responsible for the project and are not intended to create any warranty or other liability. The user\*\* is responsible for compliance with applicable building codes or other regulations and determining the suitability of the suggestions for the particular application, including the final design of reinforcement, flashing, and sealant systems for all window and door installations.  
\*\* building owner, architect, contractor, installer and/or consumer



Quote Name: Franklin Hotel Remodel - Reserve Project Name: A1 Construction - Franklin

Jobsite Location: RAPID CITY, SD

Room Location: 2F W2

Sales Branch Location: 23300 Heartland Pella

# Customer Approval Form:

Signature: \_\_\_\_\_ Date: \_\_\_\_\_

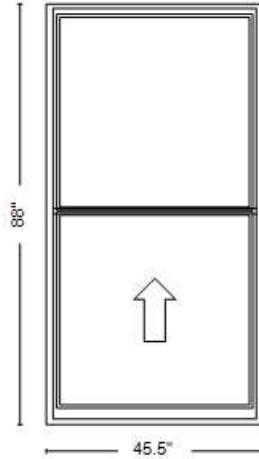

Viewed from the Exterior

Quote Number: 17978288

Line Number: 90

Quote Qty: 11

Scaling: 1/2" = 1'

Description: Pella® Reserve, , Traditional Single Hung, 45.5 X 88

Rough Opening: 46.25" X 88.75"

Performance Information: U-Factor 0.28, SHGC 0.28, VLT 0.52, CPD PEL-N-234-01145-00001, Performance Class CW, PG 30, Calculated Positive DP Rating 30, Calculated Negative DP Rating 30, Year Rated 08|11, Clear Opening Width 42.125, Clear Opening Height 39.562, Clear Opening Area 11.57326, Egress Meets Typical 5.7 sqft (E) (United States Only)

These drawings are based on our interpretation of the information provided to us. They are submitted for final approval of the individual\*\* responsible for the project and are not intended to create any warranty or other liability. The user\*\* is responsible for compliance with applicable building codes or other regulations and determining the suitability of the suggestions for the particular application, including the final design of reinforcement, flashing, and sealant systems for all window and door installations.  
\*\* building owner, architect, contractor, installer and/or consumer



Quote Name: Franklin Hotel Remodel - Reserv Project Name: A1 Construction - Franklin

Jobsite Location: RAPID CITY, SD

Room Location: 2F W3

Sales Branch Location: 23300 Heartland Pella

# Customer Approval Form:

Signature: \_\_\_\_\_ Date: \_\_\_\_\_

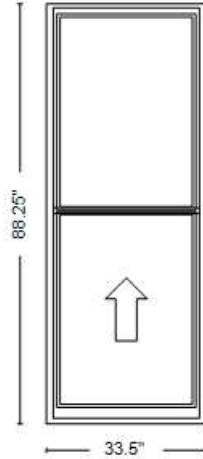

Viewed from the Exterior

Quote Number: 17978288

Line Number: 95

Quote Qty: 3

Scaling: 1/2" = 1'

Description: Pella® Reserve, , Traditional Single Hung, 33.5 X 88.25

Rough Opening: 34.25" X 89"

Performance Information: U-Factor 0.28, SHGC 0.28, VLT 0.53, CPD PEL-N-234-01141-00001, Performance Class CW, PG 30, Calculated Positive DP Rating 30, Calculated Negative DP Rating 30, Year Rated 08|11, Clear Opening Width 30.125, Clear Opening Height 39.687, Clear Opening Area 8.302575, Egress Meets Typical 5.7 sqft (E) (United States Only)

These drawings are based on our interpretation of the information provided to us. They are submitted for final approval of the individual\*\* responsible for the project and are not intended to create any warranty or other liability. The user\*\* is responsible for compliance with applicable building codes or other regulations and determining the suitability of the suggestions for the particular application, including the final design of reinforcement, flashing, and sealant systems for all window and door installations.  
\*\* building owner, architect, contractor, installer and/or consumer



Quote Name: Franklin Hotel Remodel - Reserv Project Name: A1 Construction - Franklin

Jobsite Location: RAPID CITY, SD

Room Location: 2F W4

Sales Branch Location: 23300 Heartland Pella

# Customer Approval Form:

Signature: \_\_\_\_\_ Date: \_\_\_\_\_

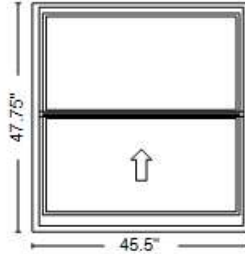

Viewed from the Exterior

Quote Number: 17978288

Line Number: 100

Quote Qty: 2

Scaling: 1/2" = 1'

Description: Pella® Reserve, , Traditional Single Hung, 45.5 X 47.75

Rough Opening: 46.25" X 48.5"

Performance Information: U-Factor 0.28, SHGC 0.28, VLT 0.53, CPD PEL-N-234-01141-00001, Performance Class CW, PG 45, Calculated Positive DP Rating 45, Calculated Negative DP Rating 45, Year Rated 08|11, Clear Opening Width 42.125, Clear Opening Height 19.437, Clear Opening Area 5.685997, Egress Does not meet typical United States egress, but may comply with local code requirements

These drawings are based on our interpretation of the information provided to us. They are submitted for final approval of the individual\*\* responsible for the project and are not intended to create any warranty or other liability. The user\*\* is responsible for compliance with applicable building codes or other regulations and determining the suitability of the suggestions for the particular application, including the final design of reinforcement, flashing, and sealant systems for all window and door installations.  
\*\* building owner, architect, contractor, installer and/or consumer



Quote Name: Franklin Hotel Remodel - Reserv Project Name: A1 Construction - Franklin

Jobsite Location: RAPID CITY, SD

Room Location: 2F W5

Sales Branch Location: 23300 Heartland Pella

# Customer Approval Form:

Signature: \_\_\_\_\_ Date: \_\_\_\_\_

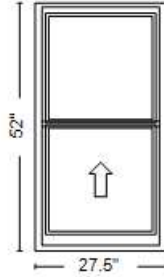

Viewed from the Exterior

Quote Number: 17978288

Line Number: 105

Quote Qty: 1

Scaling: 1/2" = 1'

Description: Pella® Reserve, , Traditional Single Hung, 27.5 X 52

Rough Opening: 28.25" X 52.75"

Performance Information: U-Factor 0.28, SHGC 0.28, VLT 0.52, CPD PEL-N-234-01145-00001, Performance Class CW, PG 45, Calculated Positive DP Rating 45, Calculated Negative DP Rating 45, Year Rated 08|11, Clear Opening Width 24.125, Clear Opening Height 21.562, Clear Opening Area 3.612384, Egress Does not meet typical United States egress, but may comply with local code requirements

These drawings are based on our interpretation of the information provided to us. They are submitted for final approval of the individual\*\* responsible for the project and are not intended to create any warranty or other liability. The user\*\* is responsible for compliance with applicable building codes or other regulations and determining the suitability of the suggestions for the particular application, including the final design of reinforcement, flashing, and sealant systems for all window and door installations.  
\*\* building owner, architect, contractor, installer and/or consumer



Quote Name: Franklin Hotel Remodel - Reserve Project Name: A1 Construction - Franklin

Jobsite Location: RAPID CITY, SD

Room Location: 2F W6 - 205 BR

Sales Branch Location: 23300 Heartland Pella

# Customer Approval Form:

Signature: \_\_\_\_\_ Date: \_\_\_\_\_

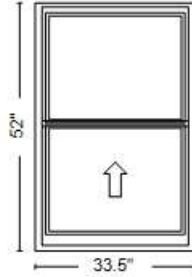

Viewed from the Exterior

Quote Number: 17978288

Line Number: 110

Quote Qty: 1

Scaling: 1/2" = 1'

Description: Pella® Reserve, , Traditional Single Hung, 33.5 X 52

Rough Opening: 34.25" X 52.75"

Performance Information: U-Factor 0.28, SHGC 0.28, VLT 0.52, CPD PEL-N-234-01145-00001, Performance Class CW, PG 45, Calculated Positive DP Rating 45, Calculated Negative DP Rating 45, Year Rated 08|11, Clear Opening Width 30.125, Clear Opening Height 21.562, Clear Opening Area 4.5108, Egress Does not meet typical United States egress, but may comply with local code requirements

These drawings are based on our interpretation of the information provided to us. They are submitted for final approval of the individual\*\* responsible for the project and are not intended to create any warranty or other liability. The user\*\* is responsible for compliance with applicable building codes or other regulations and determining the suitability of the suggestions for the particular application, including the final design of reinforcement, flashing, and sealant systems for all window and door installations.  
\*\* building owner, architect, contractor, installer and/or consumer



Quote Name: Franklin Hotel Remodel - Reserve Project Name: A1 Construction - Franklin

Jobsite Location: RAPID CITY, SD

Room Location: 2F W7 - 219 BR

Sales Branch Location: 23300 Heartland Pella

# Customer Approval Form:

Signature: \_\_\_\_\_ Date: \_\_\_\_\_

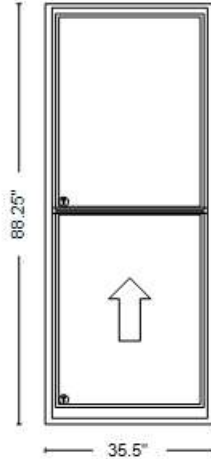

Viewed from the Exterior

Quote Number: 17978288

Line Number: 115

Quote Qty: 1

Scaling: 1/2" = 1'

Description: Pella® Reserve, , Traditional Single Hung, 35.5 X 88.25

Rough Opening: 36.25" X 89"

Performance Information: U-Factor 0.28, SHGC 0.28, VLT 0.52, CPD PEL-N-234-01145-00001, Performance Class CW, PG 30, Calculated Positive DP Rating 30, Calculated Negative DP Rating 30, Year Rated 08|11, Clear Opening Width 32.125, Clear Opening Height 39.687, Clear Opening Area 8.853784, Egress Meets Typical 5.7 sqft (E) (United States Only)

These drawings are based on our interpretation of the information provided to us. They are submitted for final approval of the individual\*\* responsible for the project and are not intended to create any warranty or other liability. The user\*\* is responsible for compliance with applicable building codes or other regulations and determining the suitability of the suggestions for the particular application, including the final design of reinforcement, flashing, and sealant systems for all window and door installations.  
\*\* building owner, architect, contractor, installer and/or consumer



Quote Name: Franklin Hotel Remodel - Reserve Project Name: A1 Construction - Franklin

Jobsite Location: RAPID CITY, SD

Room Location: 2F W8 - Emerald N Dr

Sales Branch Location: 23300 Heartland Pella



# Customer Approval Form:

Signature: \_\_\_\_\_ Date: \_\_\_\_\_

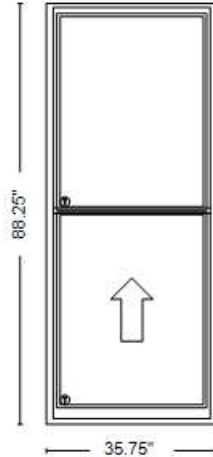

Viewed from the Exterior

Quote Number: 17978288

Line Number: 120

Quote Qty: 1

Scaling: 1/2" = 1'

Description: Pella® Reserve, , Traditional Single Hung, 35.75 X 88.25

Rough Opening: 36.5" X 89"

Performance Information: U-Factor 0.28, SHGC 0.28, VLT 0.52, CPD PEL-N-234-01145-00001, Performance Class CW, PG 30, Calculated Positive DP Rating 30, Calculated Negative DP Rating 30, Year Rated 08|11, Clear Opening Width 32.375, Clear Opening Height 39.687, Clear Opening Area 8.922685, Egress Meets Typical 5.7 sqft (E) (United States Only)

These drawings are based on our interpretation of the information provided to us. They are submitted for final approval of the individual\*\* responsible for the project and are not intended to create any warranty or other liability. The user\*\* is responsible for compliance with applicable building codes or other regulations and determining the suitability of the suggestions for the particular application, including the final design of reinforcement, flashing, and sealant systems for all window and door installations.  
\*\* building owner, architect, contractor, installer and/or consumer



Quote Name: Franklin Hotel Remodel - Reserve Project Name: A1 Construction - Franklin

Jobsite Location: RAPID CITY, SD

Room Location: 2F W9 - Emerald S Dr

Sales Branch Location: 23300 Heartland Pella

# Customer Approval Form:

Signature: \_\_\_\_\_ Date: \_\_\_\_\_

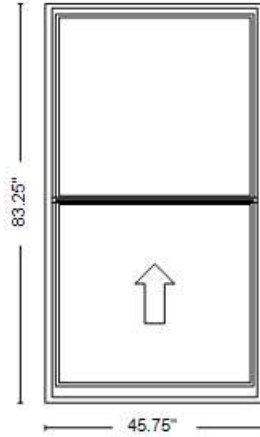

Viewed from the Exterior

Quote Number: 17978288

Line Number: 125

Quote Qty: 3

Scaling: 1/2" = 1'

Description: Pella® Reserve, , Traditional Single Hung, 45.75 X 83.25

Rough Opening: 46.5" X 84"

Performance Information: U-Factor 0.28, SHGC 0.28, VLT 0.52, CPD PEL-N-234-01145-00001, Performance Class CW, PG 40, Calculated Positive DP Rating 40, Calculated Negative DP Rating 40, Year Rated 08|11, Clear Opening Width 42.375, Clear Opening Height 37.187, Clear Opening Area 10.94305, Egress Meets Typical 5.7 sqft (E) (United States Only)

These drawings are based on our interpretation of the information provided to us. They are submitted for final approval of the individual\*\* responsible for the project and are not intended to create any warranty or other liability. The user\*\* is responsible for compliance with applicable building codes or other regulations and determining the suitability of the suggestions for the particular application, including the final design of reinforcement, flashing, and sealant systems for all window and door installations.  
\*\* building owner, architect, contractor, installer and/or consumer



Quote Name: Franklin Hotel Remodel - Reserv Project Name: A1 Construction - Franklin

Jobsite Location: RAPID CITY, SD

Room Location: 1F W1

Sales Branch Location: 23300 Heartland Pella

# Customer Approval Form:

Signature: \_\_\_\_\_ Date: \_\_\_\_\_

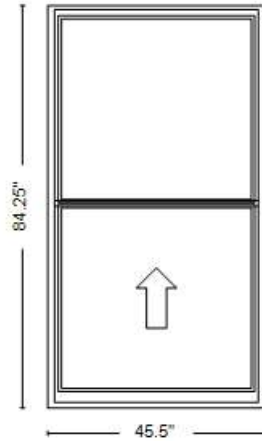

Viewed from the Exterior

Quote Number: 17978288

Line Number: 130

Quote Qty: 2

Scaling: 1/2" = 1'

Description: Pella® Reserve, , Traditional Single Hung, 45.5 X 84.25

Rough Opening: 46.25" X 85"

Performance Information: U-Factor 0.28, SHGC 0.28, VLT 0.52, CPD PEL-N-234-01145-00001, Performance Class CW, PG 30, Calculated Positive DP Rating 30, Calculated Negative DP Rating 30, Year Rated 08|11, Clear Opening Width 42.125, Clear Opening Height 37.687, Clear Opening Area 11.02476, Egress Meets Typical 5.7 sqft (E) (United States Only)

These drawings are based on our interpretation of the information provided to us. They are submitted for final approval of the individual\*\* responsible for the project and are not intended to create any warranty or other liability. The user\*\* is responsible for compliance with applicable building codes or other regulations and determining the suitability of the suggestions for the particular application, including the final design of reinforcement, flashing, and sealant systems for all window and door installations.  
\*\* building owner, architect, contractor, installer and/or consumer



Quote Name: Franklin Hotel Remodel - Reserve Project Name: A1 Construction - Franklin

Jobsite Location: RAPID CITY, SD

Room Location: 1F W2

Sales Branch Location: 23300 Heartland Pella

# Customer Approval Form:

Signature: \_\_\_\_\_ Date: \_\_\_\_\_

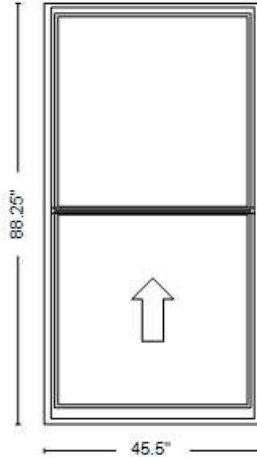

Viewed from the Exterior

Quote Number: 17978288

Line Number: 135

Quote Qty: 1

Scaling: 1/2" = 1'

Description: Pella® Reserve, , Traditional Single Hung, 45.5 X 88.25

Rough Opening: 46.25" X 89"

Performance Information: U-Factor 0.28, SHGC 0.28, VLT 0.52, CPD PEL-N-234-01145-00001, Performance Class CW, PG 30, Calculated Positive DP Rating 30, Calculated Negative DP Rating 30, Year Rated 08|11, Clear Opening Width 42.125, Clear Opening Height 39.687, Clear Opening Area 11.60983, Egress Meets Typical 5.7 sqft (E) (United States Only)

These drawings are based on our interpretation of the information provided to us. They are submitted for final approval of the individual\*\* responsible for the project and are not intended to create any warranty or other liability. The user\*\* is responsible for compliance with applicable building codes or other regulations and determining the suitability of the suggestions for the particular application, including the final design of reinforcement, flashing, and sealant systems for all window and door installations.  
\*\* building owner, architect, contractor, installer and/or consumer



Quote Name: Franklin Hotel Remodel - Reserve Project Name: A1 Construction - Franklin

Jobsite Location: RAPID CITY, SD

Room Location: 1F W3

Sales Branch Location: 23300 Heartland Pella

CUSTOMER: HUEY LONG CO INC  
 P.O.# - - - -  
 Tag: Hung Windows  
 Curved Simulated Double  
 ATTN: Brad H

MULLING / STACKING  
 Factory Jobsite  
 MULL COVERS  
 Exterior Interior

INSIDE JB RAD = 100 7/16  
 INSIDE ARC L = 44 25/64  
 OUTSIDE JB RAD = 105  
 OUTSIDE ARC L = 46 27/64

INSIDE GL RAD = 102 23/32  
 INSIDE ARC L = 45 1/16  
 OUTSIDE GL RAD = 103 23/32  
 OUTSIDE ARC L = 45 33/64

SASH:  
 Height:  
 Thickness:  
 Glazing Bead:  
 Custom: (See Dtl)

GL 45 5/32"  
 JB 47 1/2"  
 RD 48 15/32"

SASH JOINERY:  
 Coped Blind M & T  
 Historical M & T  
 Fr. Mitre Blind M & T

GL 102 7/16"  
 JB 104 1/4"  
 RD 104 3/4"

Color:  
 2-Tone Grids:  
 Flat Sculptured  
 X SDL TDL  
 SDL Sim Bars

Bar Width: 7/8"  
 EXT: CGR124  
 INT: CGR124  
 Tape X Grey Black  
 Wood Grilles

Bar Width:  
 Profile:  
 Surround:  
 Species:  
 Interior Trim

Style:  
 Species:  
 Finish:  
 Set 3 Sides  
 Arch Only  
 Trim Reveal:

NOTES:  
 \* 3/4" Bead

PLANT USE ONLY  
 SEE DTL  
 (86482X)

QUANTITY 1  
 Jamb 3/4  
 Depth 4 9/16  
 WOOD SPECIES: (EXT)  
 Pine X Sap. Mah.  
 White Oak Doug Fir  
 Other:

WOOD SPECIES: (INT)  
 Pine X Sap. Mah.  
 Red Oak Doug Fir  
 Other:

EXTERIOR FINISH  
 Poly X Primed  
 Natural Stained  
 Color: PL White

INTERIOR FINISH  
 Poly Primed X  
 Natural Stained  
 Color:

BEAD / STOP B-13 \*  
 Custom (See Dtl)  
 EXTERIOR CASING None  
 BM FC  
 Applied Loose  
 Reveal

Masonry Clips 7 1/2" X  
 Fasteners: Ext. SS / Int. Zinc  
 SUBSILL SS# None  
 Applied Loose  
 Extended Horns:

PERFORMANCE GRADE:  
 Standard X  
 Impact/Hurricane

GLASS THICKNESS: 1"  
 Low-E Pilkington  
 Outboard Lite:  
 Inboard Lite:

Clear Temp X  
 Argon X Deco  
 Breather Tubes  
 Laminated

GLASS SPACER  
 Aluminum: Black X  
 Stainless Steel:  
 Technoform:  
 Super Spacer:

DATE:  
 DATE: 04/10/2024  
 SCALE: 1/2" = 1'  
 DR BY: EE  
 CKD BY: Mark G

REF. NO. 86482  
 DWG. NO. 86482-1-1

My signature on this print indicates my approval of design and dimensions as shown and I authorize production of same. Delivery date will not be assigned until authorized written approval is received.

\*\*CAD DRAWING IS OUTSIDE VIEW\*\*  
 CUSTOMER  
 BY  
 DATE

\*Due to the custom nature of our product, this order is non-cancellable without penalty. Cancelled orders, beginning with the initiation of drawings and engineering, will be charged based on percentage of completion plus 10%.

\*Proprietary Notice: The information contained in this drawing is the sole property of Parrett Windows & Doors. Any reproduction in part or as a whole without the written permission of Parrett Windows & Doors is prohibited.

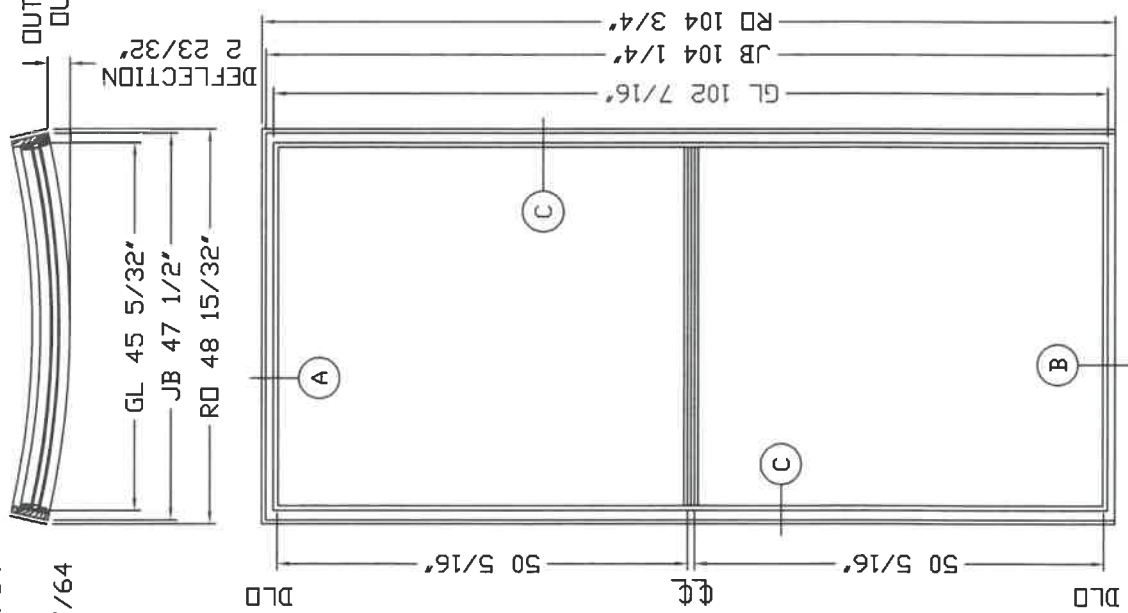

GL ✓

CUSTOMER: HUEY LONG CO INC  
 P.O.# - - - -  
 Tag: **Hung Windows**  
 Curved Simulated Double  
 ATTN: **Brad H**

MULLING / STACKING  
 Factory Jobsite  
 MULL COVERS  
 Exterior Interior  
 SASH:  
 Height:  
 Thickness:  
 Glazing Bead:  
 Custom: (See Dtl)  
 SASH JOINERY:  
 Coped Blind M & T  
 Historical M & T  
 Fr. Mire Blind M & T  
 Grille In Airspace  
 Color:  
 2-Tone Grids:  
 Flat Sculptured  
 X SDL TDL  
 SDL Sim Bars  
 Bar Width: 7/8"  
 EXT: CGR124  
 INT: CGR124  
 Tape X Grey Black  
 Wood Grilles  
 Bar Width:  
 Profile:  
 Surround:  
 Species:  
 Interior Trim  
 Style:  
 Species:  
 Finish:  
 Set 3 Sides  
 Arch Only  
 Trim Reveal:  
 NOTES:  
**\* 3/4" Bead**

PLANT USE ONLY  
**SEE DTL (86482X)**

INSIDE JB RAD = 100 7/16  
 INSIDE ARC L = 44 25/64  
 OUTSIDE JB RAD = 105  
 OUTSIDE ARC L = 46 27/64

INSIDE GL RAD = 102 23/32  
 INSIDE ARC L = 45 1/16  
 OUTSIDE GL RAD = 103 23/32  
 OUTSIDE ARC L = 45 33/64

DEFLECTION  
 R 23/32"

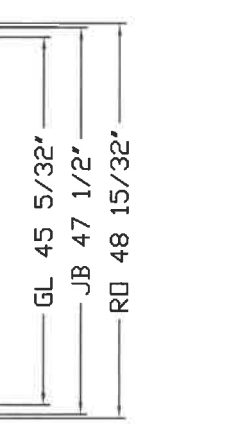

QUANTITY **1**  
 Jamb 3/4  
 Depth 4 9/16  
 WOOD SPECIES: (EXT)  
 Pine X Sap. Mah.  
 White Oak Doug Fir  
 Other:  
 WOOD SPECIES: (INT)  
 Pine X Sap. Mah.  
 Red Oak Doug Fir  
 Other:  
 EXTERIOR FINISH  
 Poly X Primed  
 Natural Stained  
 Color: **PL White**  
 INTERIOR FINISH  
 Poly Primed X  
 Natural Stained  
 Color:  
 BEAD / STOP **B-13 \***  
 Custom (See Dtl)  
 EXTERIOR CASING **None**  
 BM FC  
 Applied Loose  
 Reveal  
 Masonry Clips 7 1/2" **X**  
 Fasteners: **Ext. SS / Int. Zinc**  
 SUBSILL SS# **None**  
 Applied Loose  
 Extended Horns:  
 PERFORMANCE GRADE:  
 Standard **X**  
 Impact/Hurricane  
 GLASS THICKNESS: **1"**  
 Low-E Pilkington  
 Outboard Lite:  
 Inboard Lite:  
 Clear Temp **X**  
 Argon X Deco  
 Breather Tubes  
 Laminated  
 GLASS SPACER  
 Aluminum: **Black** **X**  
 Stainless Steel:  
 Technoform:  
 Super Spacer:

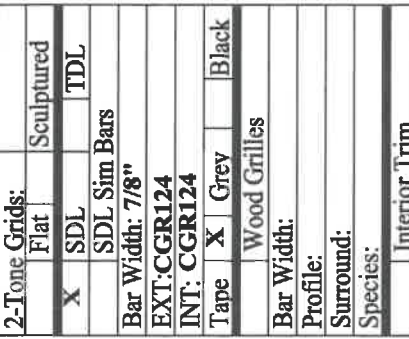

DATE:  
 DR BY: **EE**  
 REF. NO. **86482**  
 DATE: **04/10/2024**  
 CK'D BY:  
 SCALE: **1/2" = 1'**  
 Mark G

My signature on this print indicates my approval of design and dimensions as shown and I authorize production of same. Delivery date will not be assigned until authorized written approval is received.  
**\*\*CAD DRAWING IS OUTSIDE VIEW\*\***

\*Due to the custom nature of our product, this order is non-cancellable without penalty. Cancelled orders, beginning with the initiation of drawings and engineering, will be charged based on percentage of completion plus 10%.  
 \*Proprietary Notice: The information contained in this drawing is the sole property of Parrett Windows & Doors. Any reproduction in part or as a whole without the written permission of Parrett Windows & Doors is prohibited.

CUSTOMER  
 BY  
 DATE

CUSTOMER: HUEY LONG CO INC  
 P.O.# - - - -  
 Tag: **Hung Windows**  
 Curved Simulated Double  
 ATTN: **Brad H**

INSIDE JB RAD = 100 7/16  
 INSIDE ARC L = 44 25/64  
 OUTSIDE JB RAD = 105  
 OUTSIDE ARC L = 46 27/64

INSIDE GL RAD = 102 23/32  
 INSIDE ARC L = 45 1/16  
 OUTSIDE GL RAD = 103 23/32  
 OUTSIDE ARC L = 45 33/64

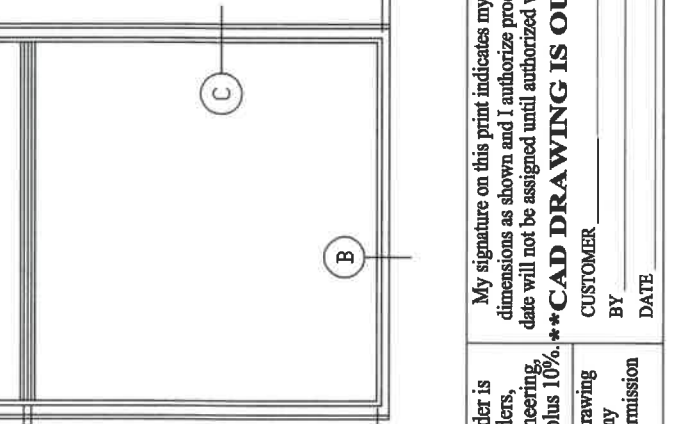

QUANTITY **1**  
 Jamb 3/4  
 Depth 4 9/16  
 WOOD SPECIES: (EXT)  
 Pine X Sap. Mah.  
 White Oak Doug Fir  
 Other:  
 WOOD SPECIES: (INT)  
 Pine X Sap. Mah.  
 Red Oak Doug Fir  
 Other:  
 EXTERIOR FINISH  
 Poly X Primed  
 Natural Stained  
 Color: **PL White**  
 INTERIOR FINISH  
 Poly Primed X  
 Natural Stained  
 Color:  
 BEAD / STOP **B-13 \***  
 Custom (See Dtl)  
 EXTERIOR CASING **None**  
 BM FC  
 Applied Loose  
 Reveal  
 Masonry Clips 7 1/2" **X**  
 Fasteners: **Ext. SS / Int. Zinc**  
 SUBSILL SS# **None**  
 Applied Loose  
 Extended Horns:  
 PERFORMANCE GRADE:  
 Standard **X**  
 Impact/Hurricane  
 GLASS THICKNESS: **1"**  
 Low-E Pilkington  
 Outboard Lite:  
 Inboard Lite:  
 Clear Temp **X**  
 Argon X Deco  
 Breather Tubes  
 Laminated  
 GLASS SPACER  
 Aluminum: **Black** **X**  
 Stainless Steel:  
 Technoform:  
 Super Spacer:

CUSTOMER: HUEY LONG CO INC  
 P.O.# - - - - -  
 Tag: **Hung Windows**  
 Curved Simulated Double  
 AITT: **Brad H**

MULLING / STACKING  
 Factory Jobsite  
 MULL COVERS  
 Exterior Interior  
 SASH:  
 Height:  
 Thickness:  
 Glazing Bead:  
 Custom: (See Dtl)  
 SASH JOINERY:  
 Coped Blind M & T  
 Historical M & T  
 Fr. Mitre Blind M & T  
 Grille In Airspace  
 Color:  
 2-Tone Grids:  
 Flat Sculptured  
 X SDL TDL  
 SDL Sim Bars  
 Bar Width: 7/8"  
 EXT: CGR124  
 INT: CGR124  
 Tape X Grey Black  
 Wood Grilles  
 Bar Width:  
 Profile:  
 Surround:  
 Species:  
 Interior Trim  
 Style:  
 Species:  
 Finish:  
 Set 3 Sides  
 Arch Only  
 Trim Reveal:  
 NOTES:  
 \* 3/4" Bead

PLANT USE ONLY  
**SEE DTL**  
**(86482X)**

INSIDE JB RAD = 100 7/16  
 INSIDE ARC L = 44 25/64  
 OUTSIDE JB RAD = 105  
 OUTSIDE ARC L = 46 27/64

INSIDE GL RAD = 102 23/32  
 INSIDE ARC L = 45 1/16  
 OUTSIDE GL RAD = 103 23/32  
 OUTSIDE ARC L = 45 33/64

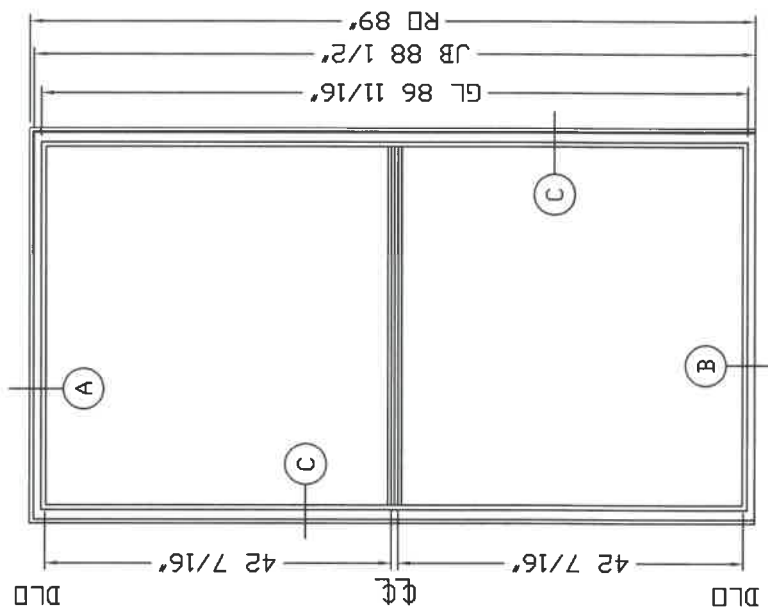
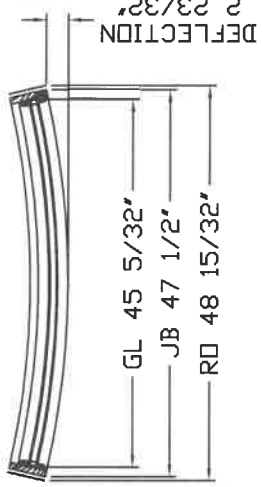

QUANTITY **2**  
 Jamb 3/4  
 Depth 4 9/16  
 WOOD SPECIES: (EXT)  
 Pine X Sap. Mah.  
 White Oak Doug Fir  
 Other:  
 WOOD SPECIES: (INT)  
 Pine X Sap. Mah.  
 Red Oak Doug Fir  
 Other:

EXTERIOR FINISH  
 Poly X Primed  
 Natural Stained  
 Color: **PL White**  
 INTERIOR FINISH  
 Poly Primed X  
 Natural Stained  
 Color:

BEAD / STOP **B-13**  
 Custom (See Dtl)  
 EXTERIOR CASING **None**  
 BM FC  
 Applied Loose  
 Reveal  
 Masonry Clips 7 1/2" X  
 Fasteners: **Ext. SS / Int. Zinc**

SUBSILL SS# **None**  
 Applied Loose  
 Extended Horns:  
 PERFORMANCE GRADE:  
 Standard X  
 Impact/Hurricane

GLASS THICKNESS: **1"**  
 Low-E Pilkington  
 Outboard Lite:  
 Inboard Lite:  
 Clear Temp X  
 Argon X Deco  
 Breather Tubes  
 Laminated

GLASS SPACER  
 Aluminum: **Black** X  
 Stainless Steel:  
 Technoform:  
 Super Spacer:

DATE:  
 DATE: **04/10/2024**  
 SCALE: **1/2" = 1'**  
 DR BY: **EE**  
 CK'D BY:  
 REF. NO. **86482**  
 DWG. NO. **86482-3-1**

My signature on this print indicates my approval of design and dimensions as shown and I authorize production of same. Delivery date will not be assigned until authorized written approval is received.  
**\*\*CAD DRAWING IS OUTSIDE VIEW\*\***  
 CUSTOMER  
 BY  
 DATE

\*Due to the custom nature of our product, this order is non-cancellable without penalty. Cancelled orders, beginning with the initiation of drawings and engineering, will be charged based on percentage of completion plus 10%.  
 \*Proprietary Notice: The information contained in this drawing is the sole property of Parrett Windows & Doors. Any reproduction in part or as a whole without the written permission of Parrett Windows & Doors is prohibited.

CUSTOMER: HUEY LONG CO INC  
 P.O.# - - - -  
 Tag: Hung Windows  
 Curved Simulated Double  
 AITN: Brad H

MULLING / STACKING  
 Factory Jobsite  
 MULL COVERS  
 Exterior Interior  
 SASH:  
 Height:  
 Thickness:  
 Glazing Bead:  
 Custom: (See Dtl)  
 SASH JOINERY:  
 Coped Blind M & T  
 Historical M & T  
 Fr. Mitre Blind M & T  
 Grille In Airspace  
 Color:  
 2-Tone Grids:  
 Flat Sculptured  
 X SDL TDL  
 SDL Sim Bars  
 Bar Width: 7/8"  
 EXT: CGR124  
 INT: CGR124  
 Tape X Grey Black  
 Wood Grilles  
 Bar Width:  
 Profile:  
 Surround:  
 Species:  
 Interior Trim  
 Style:  
 Species:  
 Finish:  
 Set 3 Sides  
 Arch Only  
 Trim Reveal:  
 NOTES:  
 \* 3/4" Bead

PLANT USE ONLY  
 SEE DTL  
 (86482X)

INSIDE JB RAD = 100 7/16  
 INSIDE ARC L = 44 25/64  
 OUTSIDE JB RAD = 105  
 OUTSIDE ARC L = 46 27/64

INSIDE GL RAD = 102 23/32  
 INSIDE ARC L = 45 1/16  
 OUTSIDE GL RAD = 103 23/32  
 OUTSIDE ARC L = 45 33/64

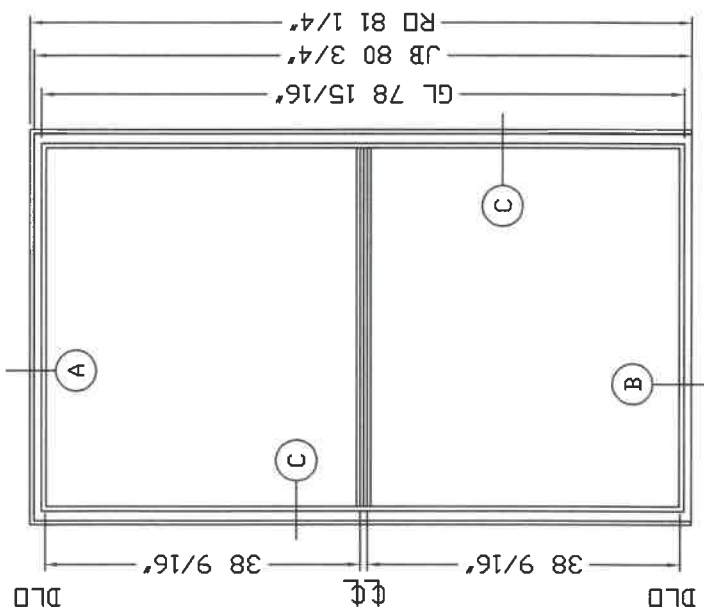
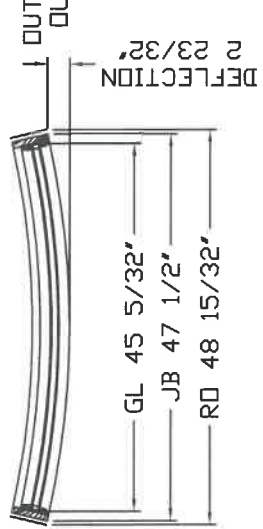

QUANTITY 4  
 Jamb 3/4  
 Depth 4 9/16  
 WOOD SPECIES: (EXT)  
 Pine X Sap. Mah.  
 White Oak Doug Fir  
 Other:  
 WOOD SPECIES: (INT)  
 Pine X Sap. Mah.  
 Red Oak Doug Fir  
 Other:  
 EXTERIOR FINISH  
 Poly X Primed  
 Natural Stained  
 Color: PL White  
 INTERIOR FINISH  
 Poly Primed X  
 Natural Stained  
 Color:  
 BEAD / STOP B-13 \*  
 Custom (See Dtl)  
 EXTERIOR CASING None  
 BM FC  
 Applied Loose  
 Reveal  
 Masonry Clips 7 1/2" X  
 Fasteners: Ext. SS / Int. Zinc  
 SUBSILL SS# None  
 Applied Loose  
 Extended Horns:  
 PERFORMANCE GRADE:  
 Standard X  
 Impact/Hurricane  
 GLASS THICKNESS: 1"  
 Low-E Pilkington  
 Outboard Lite:  
 Inboard Lite:  
 Clear Temp X  
 Argon X Deco  
 Breather Tubes  
 Laminated  
 GLASS SPACER  
 Aluminum: Black X  
 Stainless Steel:  
 Technoform:  
 Super Spacer:

DATE:  
 DATE: 04/10/2024  
 SCALE: 1/2" = 1'  
 DR BY: EE  
 CK'D BY:  
 REF. NO. 86482  
 DWG. NO.  
 Mark G 86482-4-1

My signature on this print indicates my approval of design and dimensions as shown and I authorize production of same. Delivery date will not be assigned until authorized written approval is received.  
 \*\*CAD DRAWING IS OUTSIDE VIEW\*\*  
 CUSTOMER  
 BY  
 DATE

\*Due to the custom nature of our product, this order is non-cancellable without penalty. Cancelled orders, beginning with the initiation of drawings and engineering, will be charged based on percentage of completion plus 10%.  
 \*Proprietary Notice: The information contained in this drawing is the sole property of Parrett Windows & Doors. Any reproduction in part or as a whole without the written permission of Parrett Windows & Doors is prohibited.



CUSTOMER: HUEY LONG CO INC  
 P.O.# - - - -  
 Tag: Hung Windows  
 Curved Simulated Double  
 ATTN: Brad H

MULLING / STACKING  
 Factory Jobsite  
 MULL COVERS  
 Exterior Interior  
 SASH:  
 Height:  
 Thickness:  
 Glazing Bead:  
 Custom: (See Dtl)

SASH JOINERY:  
 Coped Blind M & T  
 Historical M & T  
 Fr. Mitre Blind M & T  
 Grille In Airspace  
 Color:  
 2-Tone Grids:  
 Flat Sculptured  
 X SDL TDL  
 SDL Sim Bars  
 Bar Width: 7/8"  
 EXT: CGR124  
 INT: CGR124  
 Tape X Grey Black  
 Wood Grilles  
 Bar Width:  
 Profile:  
 Surround:  
 Species:  
 Interior Trim  
 Style:  
 Species:  
 Finish:  
 Set 3 Sides  
 Arch Only  
 Trim Reveal:  
 NOTES:  
 \* 3/4" Bead

INSIDE JB RAD = 100 7/16  
 INSIDE ARC L = 44 25/64  
 OUTSIDE JB RAD = 105  
 OUTSIDE ARC L = 46 27/64

INSIDE GL RAD = 102 23/32  
 INSIDE ARC L = 45 1/16  
 OUTSIDE GL RAD = 103 23/32  
 OUTSIDE ARC L = 45 33/64

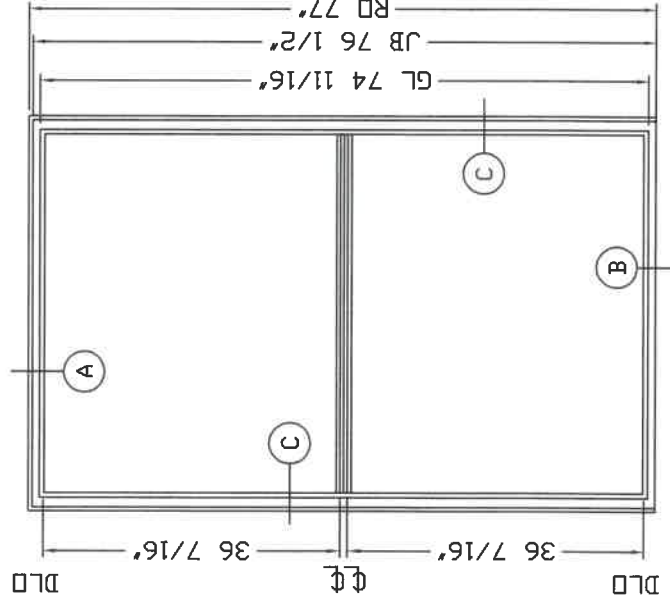
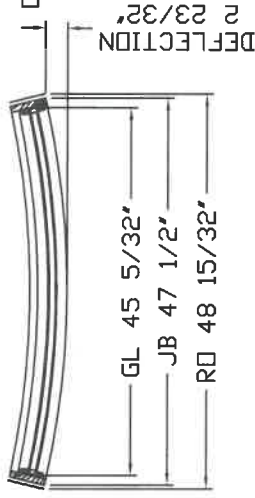

<b>QUANTITY</b>	<b>4</b>
Jamb	3/4
Depth	4 9/16
<b>WOOD SPECIES: (EXT)</b>	
Pine	X Sap. Mal.
White Oak	Doug Fir
Other:	
<b>WOOD SPECIES: (INT)</b>	
Pine	X Sap. Mah.
Red Oak	Doug Fir
Other:	
<b>EXTERIOR FINISH</b>	
Poly	X Primed
Natural	Stained
Color: PL White	
<b>INTERIOR FINISH</b>	
Poly	Primed X
Natural	Stained
Color:	
<b>BEAD / STOP B-13 *</b>	
Custom (See Dtl)	
<b>EXTERIOR CASING None</b>	
BM	FC
Applied	Loose
Reveal	
Masonry Clips 7 1/2" X	
Fasteners: Ext. SS / Int. Zinc	
<b>SUBSILL SS# None</b>	
Applied	Loose
Extended Horns:	
<b>PERFORMANCE GRADE:</b>	
Standard	X
Impact/Hurricane	
<b>GLASS THICKNESS: 1"</b>	
Low-E Pilkington	
Onboard Lite:	
Inboard Lite:	
Clear	Temp X
Argon	X Deco
Breather Tubes	
Laminated	
<b>GLASS SPACER</b>	
Aluminum:	Black X
Stainless Steel:	
Technoform:	
Super Spacer:	

\*Due to the custom nature of our product, this order is non-cancellable without penalty. Cancelled orders, beginning with the initiation of drawings and engineering, will be charged based on percentage of completion plus 10%. \*\*CAD DRAWING IS OUTSIDE VIEW\*\*  
 \*Proprietary Notice: The information contained in this drawing is the sole property of Parrett Windows & Doors. Any reproduction in part or as a whole without the written permission of Parrett Windows & Doors is prohibited.

My signature on this print indicates my approval of design and dimensions as shown and I authorize production of same. Delivery date will not be assigned until authorized written approval is received.  
 CUSTOMER: \_\_\_\_\_  
 DATE: \_\_\_\_\_

DATE: \_\_\_\_\_  
 DR BY: EE  
 REF. NO. 86482  
 04/10/2024  
 CKD BY: Mark G  
 DWG. NO. 86482-5-1  
 SCALE: 1/2" = 1'

PLANT USE ONLY  
 SEE DTL  
 (86482X)



# Wood Direct Set

Curved Sill Detail

EXTERIOR

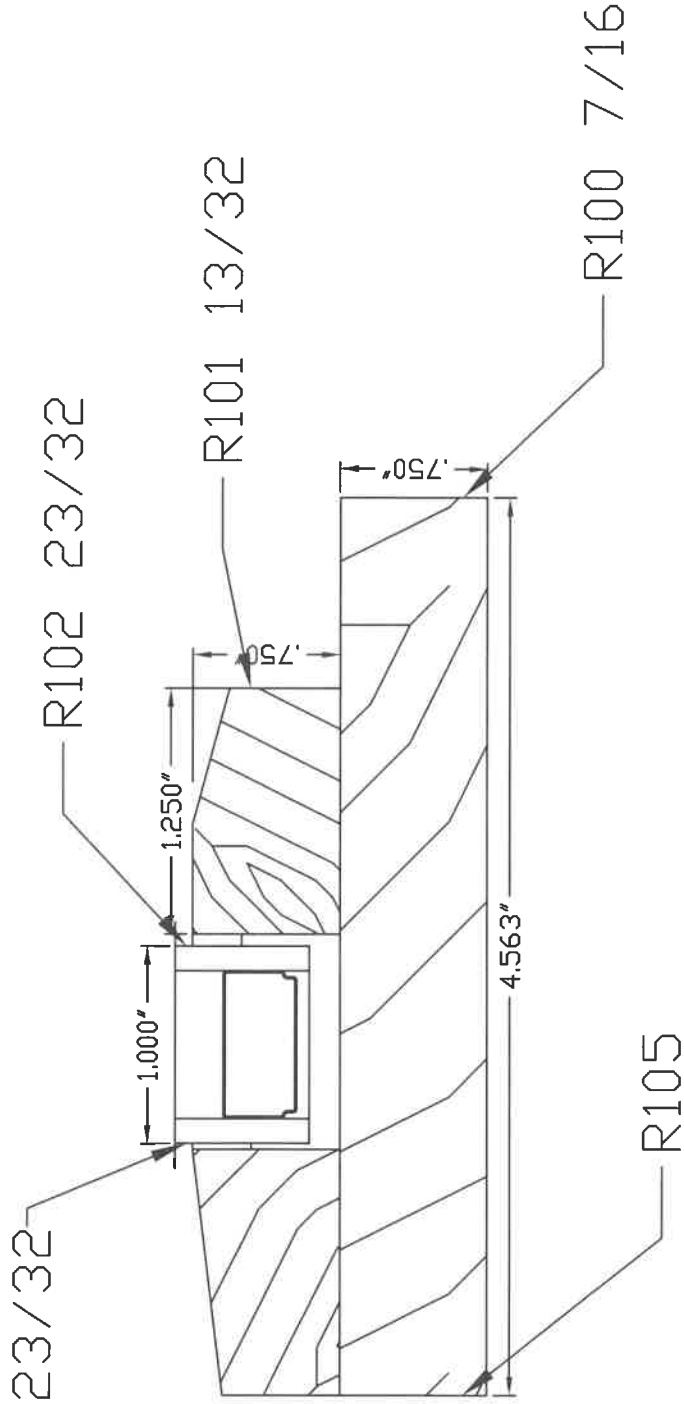

Proprietary Notice: The information contained in this drawing is the sole property of Parrett Windows & Doors. Any reproduction in part or as a whole without the written permission of Parrett Windows & Doors is prohibited.

MY SIGNATURE ON THIS PRINT INDICATES MY APPROVAL OF DESIGN AND DIMENSIONS AS SHOWN AND I AUTHORIZE PRODUCTION OF SAME. DELIVERY DATE WILL NOT BE ASSIGNED UNTIL AUTHORIZED WRITTEN APPROVAL IS RECEIVED.

DATE	REVISION / ECN	BY

CUSTOMER BY DATE		HUEY LONG CO INC DETAIL: <b>B</b> SCALE: <b>FULL</b> DATE: <b>04/10/2024</b>	
DR BY: <b>EE</b> REF. NO. <b>86482</b>		CKD BY: <b>Mark G</b> DWG. NO. <b>86482X</b>	

# Wood Direct Set

Side & SDL Detail

EXTERIOR

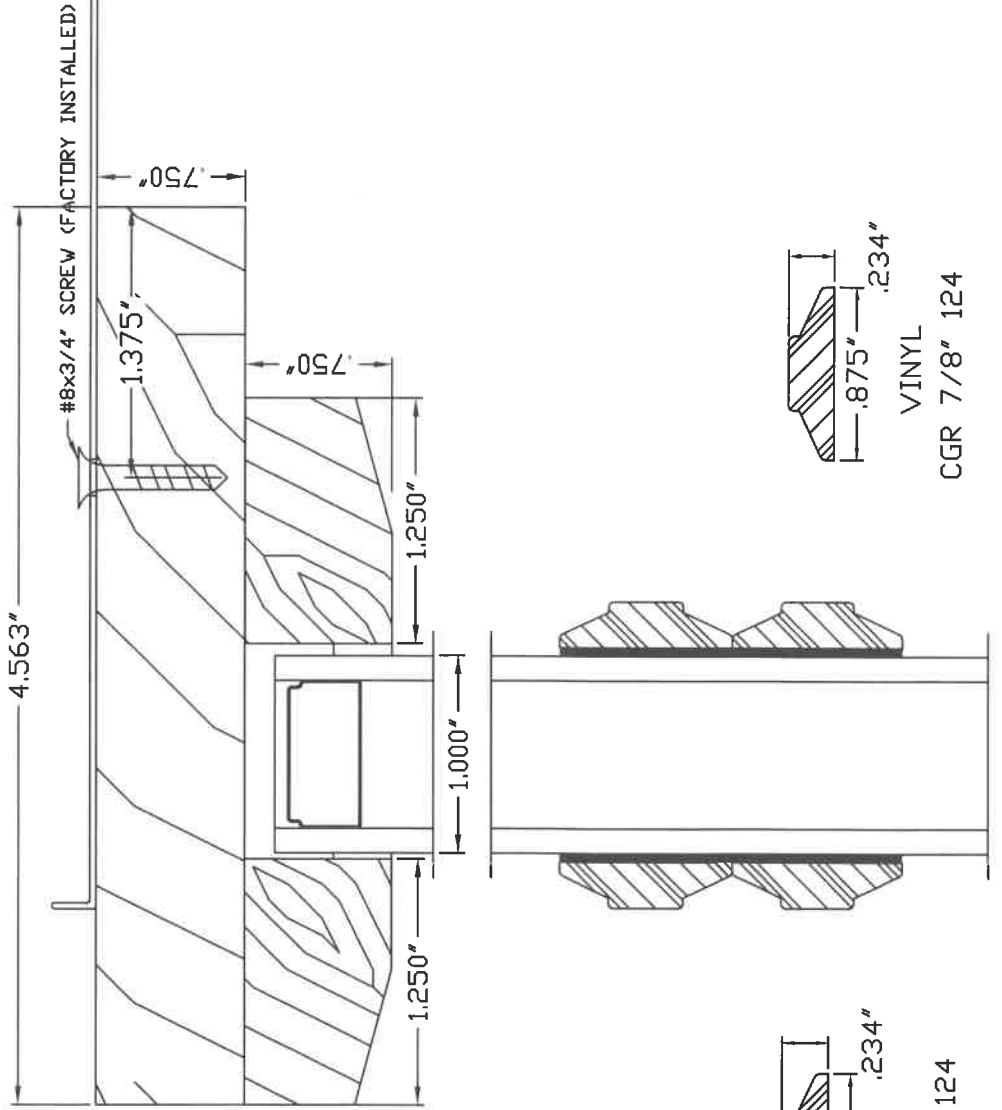

CUSTOMER BY DATE		MY SIGNATURE ON THIS PRINT INDICATES MY APPROVAL OF DESIGN AND DIMENSIONS AS SHOWN AND I AUTHORIZE PRODUCTION OF SAME. DELIVERY DATE WILL NOT BE ASSIGNED UNTIL AUTHORIZED WRITTEN APPROVAL IS RECEIVED.	
DR. BY: <b>EE</b> REF. NO. <b>86482</b> DWG. NO. <b>86482X</b>	CK'D BY: <b>Mark G</b> Mark G	<b>HUEY LONG CO INC</b> HUEY LONG CO INC	HUEY LONG CO INC
DATE: <b>04/10/2024</b> SCALE: <b>FULL</b>	DETAIL: <b>C</b>	DATE REVISION / ECN	DATE REVISION / ECN
NO BY	NO BY	NO BY	NO BY