



CITY COUNCIL AGENDA REQUEST

Meeting Type:	Mayor & Council Meeting
Meeting Date:	1/6/2025
Agenda Item:	West Franklin Street and Valley Drive Stormwater Bypass System Dalton Project No. PW-2024-BD-161-2 Consideration for Contract Award to Wright Brothers Construction Company, Inc.
Department:	Public Works
Requested By:	Chad Townsend
Reviewed/Approved by City Attorney?	Yes
Cost:	\$2,191,164.00
Funding Source if Not in Budget	Bonded Capital

Please Provide A Summary of Your Request, Including Background Information to Explain the Request:

This request is to award the West Franklin Street and Valley Drive Stormwater Bypass System Dalton Project to Wright Brothers Construction Company, Inc. This project is considered as “Phase 3” of the proposed Walnut North Drainage Improvements by the engineering consultant Arcadis.

If the Contract is awarded, construction shall be completed within 24 weeks following issuance of the official “Notice to Proceed” by the City.

See attached contract documents for additional information about the scope of services.

CITY OF DALTON, GEORGIA



CONTRACT DOCUMENTS

For
PROJECT:

**WEST FRANKLIN STREET AND VALLEY DRIVE STORMWATER BYPASS SYSTEM
DALTON PROJECT NO. PW-2024-BD-161-2**

**CITY OF DALTON PUBLIC WORKS DEPARTMENT
PO BOX 1205
DALTON, GEORGIA 30722**

CONTRACT ADDENDUM

ADDENDA NO.: 001

DATE ISSUED: November 8th, 2024

BID DATE: November 20th, 2024

BID TIME: 2 PM ET

BID LOCATION: City of Dalton Finance Department

CONTRACTOR ACTION:

1. Acknowledge receipt of the first addendum by writing in "Addenda No. 1" on page 0200-3 of bid submission.
2. Please replace original bid form with the revised bid form included within this published addendum.

INTERPRETATIONS

ALL RESPONSES TO QUESTIONS RECEIVED ARE PROVIDED IN RED BELOW.

- 1) Work hours 7:30am-5:30pm mandatory: If we have emergency utilities that we are trying to repair, will you wave the \$200/hour after 5:30?
 - a) In the event that emergency utility work occurs that is required to maintain service to surrounding properties after hours and/or the situation poses a threat to life and safety within the impacted corridor, contractor shall be required to notify the Public Works Department Project Manager as soon as such situation occurs. Contractor shall be permitted to conduct emergency repairs after hours once the Public Works Department's Project Manager has been notified.
- 2) Traffic Control:
 - a) Are we required to submit a traffic control plan?
 - i) Contractor shall be required to submit a written and visual traffic control plan prior to being issued a Notice to Proceed for construction by the City.
 - b) Can we 1-lane both Franklin St. & Valley Dr. simultaneously? This would allow us the option to use 2 crews.
 - i) Contractor may submit a detailed traffic control plan proposing construction commencing simultaneously at multiple locations within the project limits. Traffic control plan must illustrate that access for emergency vehicles and surrounding residents shall be maintained at all times in order to be considered by the City. Acceptance of proposed traffic control plans shall remain at the discretion of the City once delivered for consideration.
 - c) Temporary fencing around our open trench cut nightly for safety of homeowners. Can we get a pay item for this?

-
- i) Contractor shall be required to maintain temporary chain link fencing around any open trenches within the project limits at all times whenever left unattended. Temporary fencing shall be accounted for within the 'Traffic Control' line item of the bid form.
- 3) Per plans, shows 95% compaction on trench backfill & temporary GAB, 98% on permanent GAB. Is this required, if so who is responsible to provide? If yes, trench backfill is required in 6" lifts, will all lifts be tested?
- a) Specified compaction percentages of the graded aggregate base layer is the required standard for compaction within open trenches within the roadway. Although periodic testing results are not required to be provided by the contractor, all backfilled trenches within the roadway must pass a proof roll witnessed by the City prior to commencement of asphalt paving. The City also reserves the right to conduct periodic compaction tests throughout the life of the project.
- 4) Contractor is to provide a N.O.I. & do NPDES inspections. Will the City have anyone reviewing our inspections?
- a) Representatives from the City may request a copy of the NPDES inspections for review periodically throughout the life of the project. A line item to cover costs associated with the required permitting for the project has also been incorporated within the revised bid form included below within this published addendum. Additionally, a lump sum line item for N.O.I, N.O.T, and NPDES monitoring has been included within the revised bid form within this published addendum.
- 5) Will water sampling be required?
- a) Water sampling shall be required at the outfall of the new drainage system, and wherever specified within associated construction permits of the project.
- 6) Line item #13 Remove and Replace landscape wall and wooden bridge: Will we be using existing wall and bridge or replace?
- a) Contractor shall reuse existing bridge and landscape wall materials wherever removal is required for completion of any construction elements within the property of 620 McFarland Avenue.
- 7) Storm drain install inspections: Will the City be inspecting or? Will we be required to run a camera through storm drain for inspections?
- a) The City will conduct periodic inspections of all stormwater elements installed through the life of the project. Contractor will not be required to provide pre-or-post construction CCTV footage.
- 8) Storm drain backfill: Safety Concern (Everything is 11'-19' deep with numerous utility conflicts restricting the use of trench boxes)
- a) If we elect to backfill with 57's instead of dirt like required, will this be acceptable?
 - i) Contractor shall be permitted to utilize washed 57 stone within the open trenches in lieu of suitable soils backfill granted compaction requirements can be met to pass a proof roll prior to paving efforts commencing. All costs for stone regardless of planned quantities utilized shall be incorporated within contractor's base bid.
 - b) If yes, how far, if not all the way? (4' below asphalt would meet Osha requirements without a trench box) If no, we will have to haul the dirt offsite and then haul it back in to backfill: Does the City have a close by stock pile yard?
 - i) Refer to response to question "8)a)" for clarification of permitted stone backfill. An aerial overview of the proximity to the stock pile yard and material staging area has been provided below. Contractor shall make continuous good faith efforts to keep spoil site in as neat and orderly as possible. All permitted contractor use of this location by the City shall be conducted in a manner that does not impede with daily operations currently performed by the City at this location. Contractor shall also
-

make continuously good faith effort not to impede with cemetery burials taking place during working hours for the life of the project. Contractor shall be required to coordinate with the City's cemetery sexton regarding working around cemetery activities as necessary for the life of the project.



Figure 1 Aerial Overview of Spoil Site and Material Staging Area

- 9) Line item #24 Clearing & Grubbing 705-707 Valley Drive: The clearing and grubbing at station 11+00-14+52, will this be in other items or?
 - a) A "Miscellaneous Clearing and Grubbing" line item has been added within the revised bid form to account for all other flora clearing required to complete the project with the exception of the Tree Removal line item. Please refer to response to question 12 within published addendum for clarification regarding Tree Removal line item.
- 10) Line item #19 Relocate existing water main: There are no details given on what's required, can we get some clarification?
 - a) Standard details that the contractor shall be required to adhere to for relocating existing water mains within the project limits have been included below within this published addendum.
- 11) Line item #20 Relocate existing gas main: There are no details given on what's required, can we get some clarification?
 - a) Line items associated with gas main relocations have been removed from the revised bid form included within this published addendum. Contractor shall be required to coordinate with Dalton Utilities for any gas line relocations, and Dalton Utilities shall bill the City for the relocation costs incurred for all required gas conflict adjustments throughout the project limits. Contractor shall be required to notify the Public Works

- Project Manager once any gas conflicts occur. Any costs incurred from damaged or relocated service lines that both are shown within the construction plan set, and are not in direct conflict with any storm drain elements being installed will be considered as contractor negligence, and shall be completed at the cost of the contractor.
- 12) Line item #21 Tree Removal 1 each: This is for the large tree at beginning of project station 0+10?
 - a) Line Item "Tree Removal" accounts for the one large hard wood tree specified on sheet C-09 of the demolition plans within the construction plan set.
 - 13) Line item #23 Remove & Replace Fence: Are we installing existing fence back or installing new? Will we be required to put up temporary fence until the permanent is installed due to homeowner's pets?
 - a) Contractor shall be required to install new matching perimeter fencing in like kind wherever removed to complete any element of the project. The City shall be responsible for constructing all temporary fencing elements for accommodating homeowner pets for the life of the project.
 - 14) Line item #31 Custom Headwalls: Will concrete testing be required?
 - a) Any material testing shall be conducted at the discretion of the City at no additional cost to the contractor.
 - 15) Line item #46 Curb & Gutter: Will concrete testing be required?
 - a) Any material testing shall be conducted at the discretion of the City at no additional cost to the contractor.
 - 16) 702 Valley Drive has a concrete mailbox that will have to be removed, will this be the responsibility of the Contractor or the City?
 - a) The City shall be responsible for removing and replacing all mailboxes residing within the limits of disturbance of the project. Contractor shall be required to notify the Public Works Project Manager in writing at least seven days prior to any conflicting mail box requiring to be removed to allow for ample time to coordinate accommodations with impacted residences prior to removal.
 - 17) Station 11+50 has several guy wires in conflict with the storm drainage, will this be the responsibility of the Contractor or the City?
 - a) Contractor shall be responsible to coordinate with Dalton Utilities any overhead power conflicts within the project limits.
 - 18) If we encounter house or yard gutter drains, how do you want them tied into storm drain? Can we get a pay item for this?
 - a) Contractor shall be required to tie any existing gutter drains encountered within the project limits to the nearest stormwater structure that provides positive drainage. Contractor shall be required to notify in writing the Public Works Project Manager of any existing unknown drains requiring relocation into the newly constructed drainage system. A line item has been added within the revised bid form included within this published addendum to account for potential yard / gutter drains requiring connections into the new system. Standard material for yard/gutter drain connections shall be single walled HDPE. The Public Works Project Manager shall confirm relocation quantities prior to billing.
 - 19) Structures that are to be replaced on Miller Street, replacing just the tops or the whole structure?
 - a) Existing catch basins specified to be replaced with drop inlets are considered as inlet conversions. Structures will be permitted to be converted via removal and replacement of catch basin tops to drop inlet tops if existing structures allow. If retrofitting is not possible, the whole structure shall be required to be replaced.

- 20) Line item #67 Unsuitable Soils: If we have any trench wall collapse due to poor material or previous compaction issues that requires us to re-sawcut outside of our trench limits, will we get paid under this item to repair?
- a) Additional saw cutting required due to stabilization issues of the edges of the open trenching shall be billed under owner directed work. No unsuitable soils can be billed for trench wall collapses in areas where it has been determined that shoring efforts are not constructed in a manner that complies with current OSHA Trenching and Excavation standards.

UTILITY SERVICE STANDARD DETAILS

Utility details provided below are the typical standards for reconstructed utility lines associated with this project.

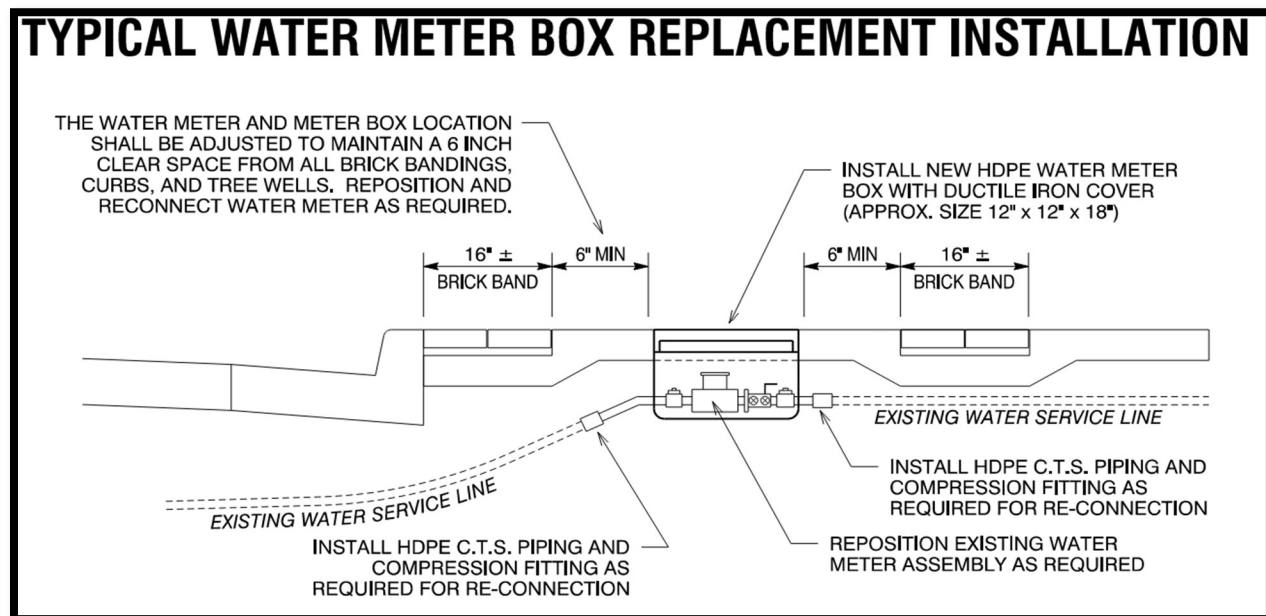
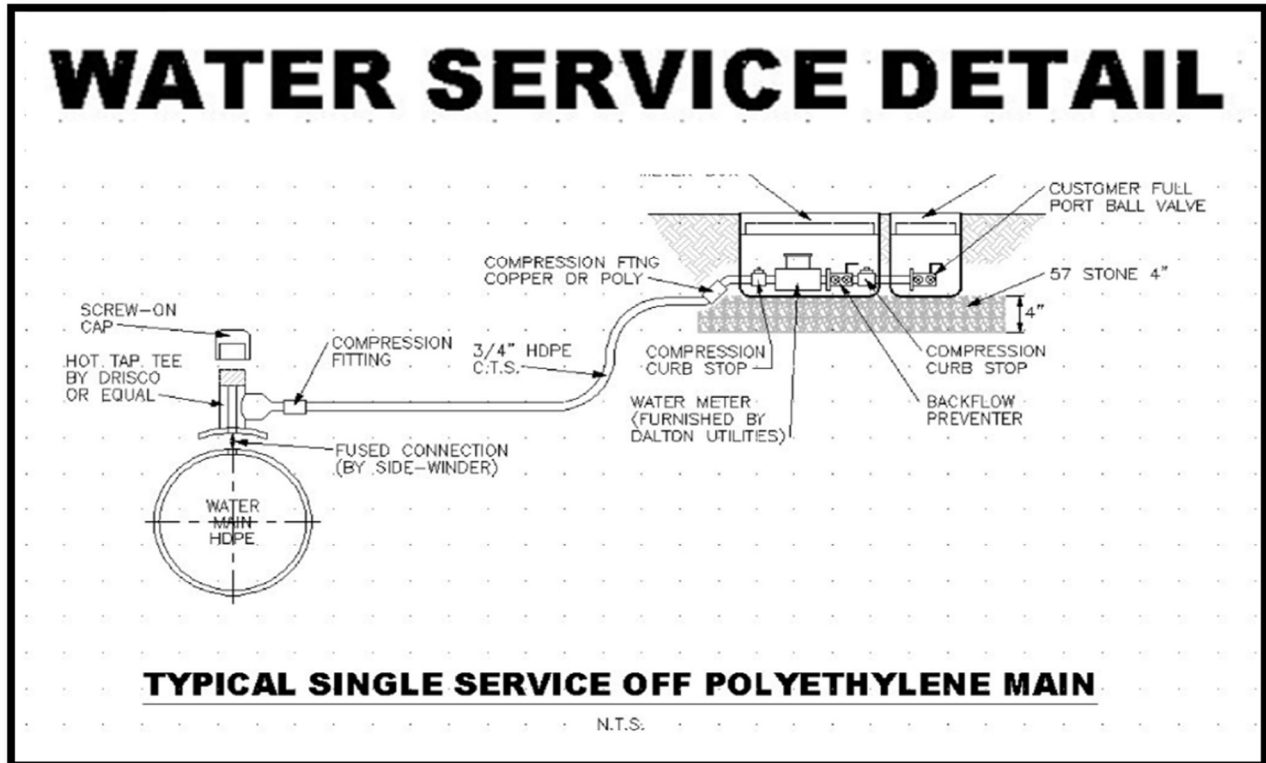

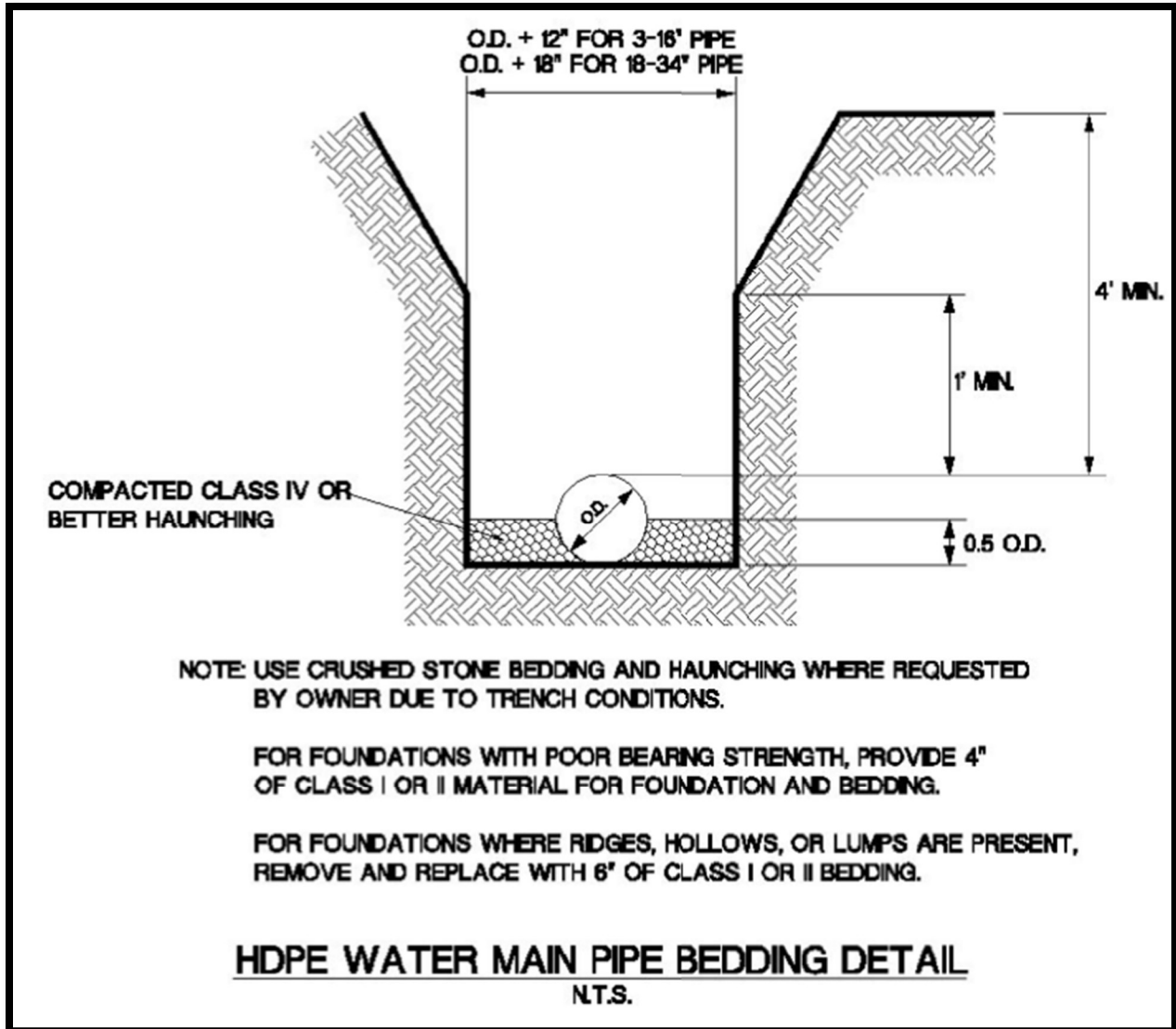

UTILITY CONFLICT ADJUSTMENT DETAIL - WATER MAIN

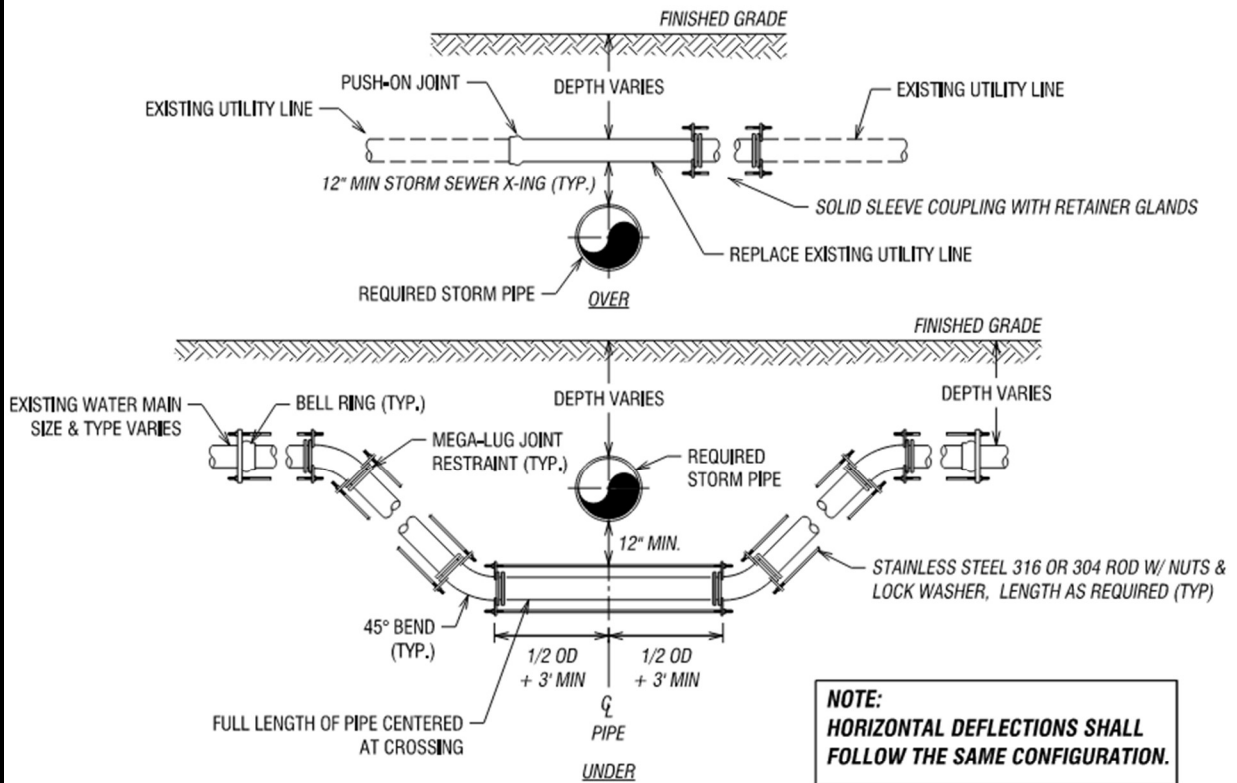

GENERAL NOTES:
WHERE WATER PIPE CROSSES UNDER RCP STORM SEWERS, THE RCP PIPE JOINTS SHALL MEET ASTM C433 FLAT GASKET JOINTS OR ASTM C361 "O-RING" JOINTS WITHIN 10 FEET OF THE WATER MAIN.

MAIN DIAMETER	NUMBER OF TIE RODS REQUIRED	SIZE OF RODS
3" TO 8"	2	3/4"
10" TO 12"	4	3/4"
14" TO 16"	6	3/4"
18" TO 20"	8	3/4"

TYPICAL "WET" TAP

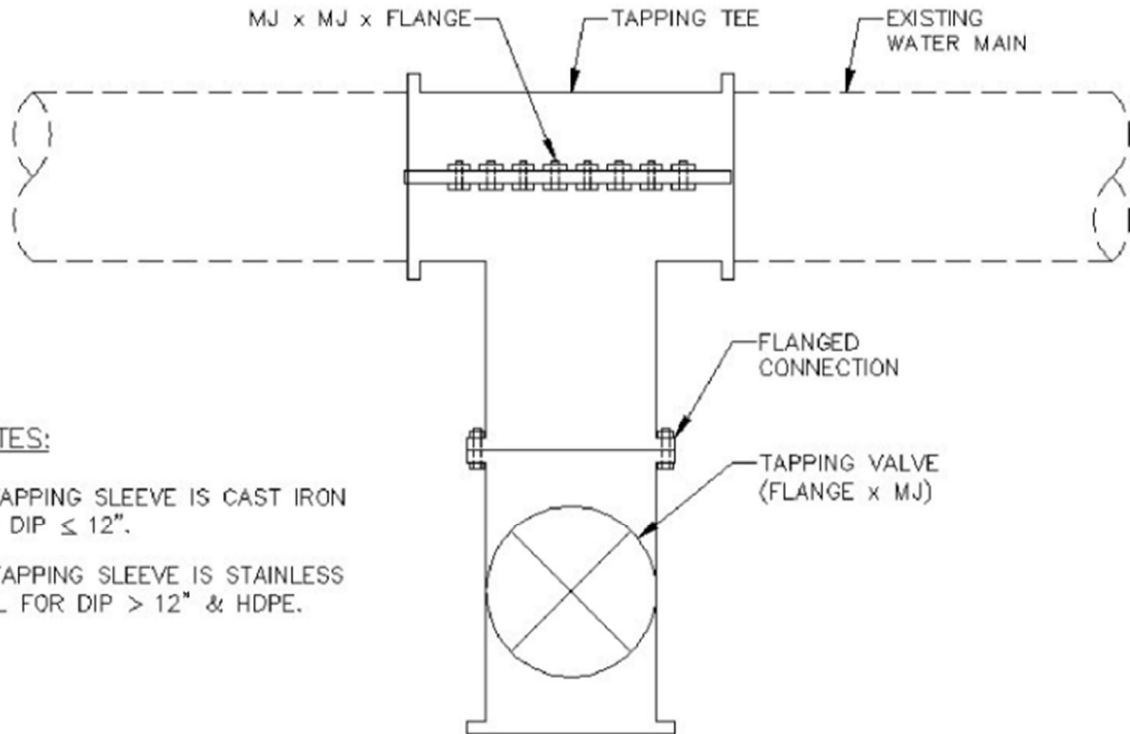

NOTES:

1. TAPPING SLEEVE IS CAST IRON FOR DIP $\leq 12"$.
2. TAPPING SLEEVE IS STAINLESS SEEL FOR DIP $> 12"$ & HDPE.

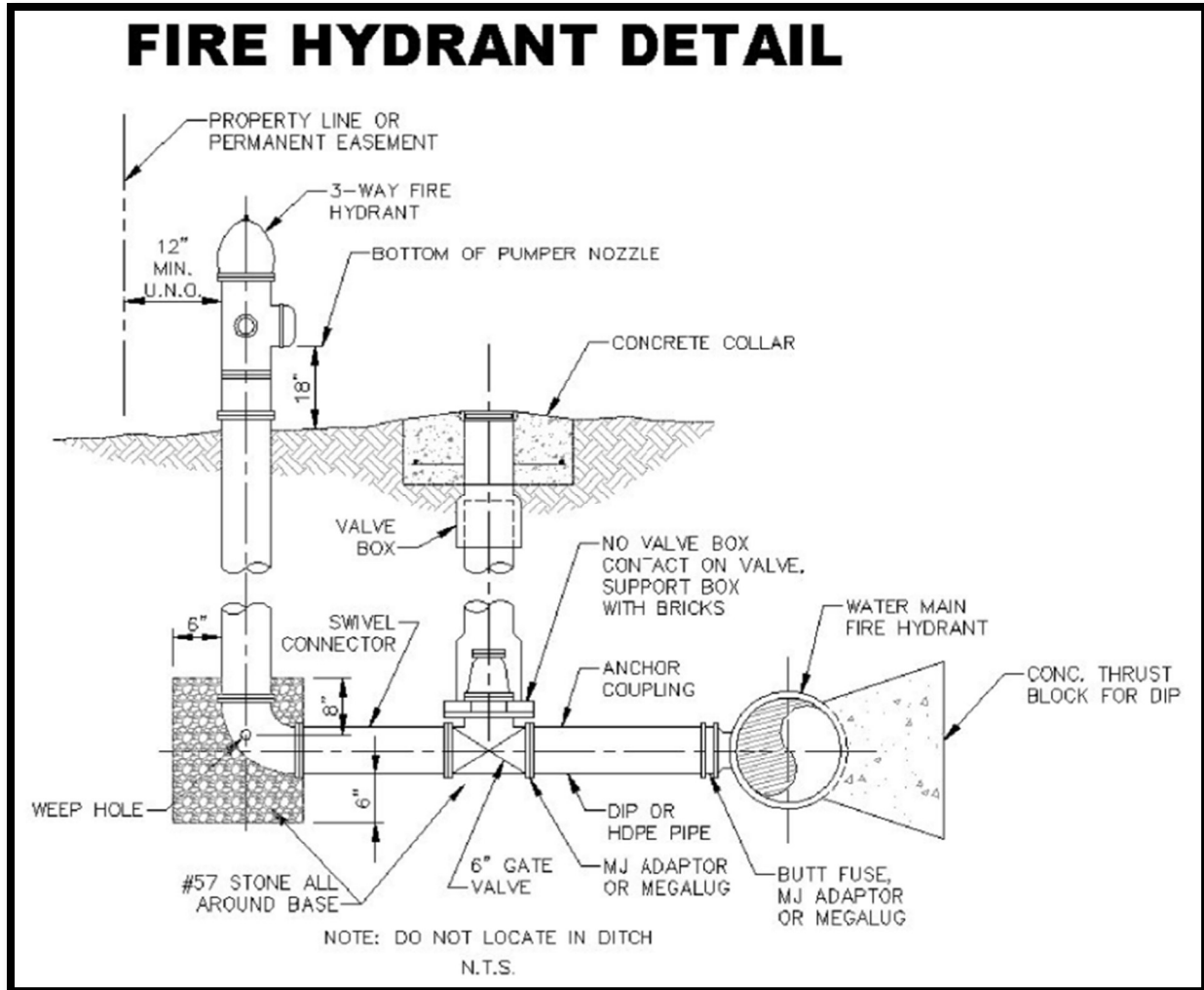

CONCRETE BLOCKING DIMENSIONS

PIPE SIZE	FITTINGS (DEGREES)	L	END DIMENSIONS OF BLOCK AGAINST UNDISTURBED SOIL (IN FEET)		CUBIC YARDS OF CONCRETE
			D	W	
4" & 6"	11 1/4°	0'-6"	10	14	0.02
	22 1/2°	0'-9"	12	23	0.04
	45°	1'-3"	16	3.2	0.13
	90°	1'-6"	22	4.4	0.28
	TEE or DE	1'-3"	18	3.7	0.16
8"	11 1/4°	0'-9"	15	3.0	0.07
	22 1/2°	1'-3"	22	4.4	0.24
	45°	1'-9"	3.1	6.1	0.82
	90°	2'-6"	4.2	8.3	1.62
	TEE or DE	2'-0"	3.0	8.0	0.89
12"	11 1/4°	0'-9"	16	3.1	0.08
	22 1/2°	1'-3"	23	4.5	0.26
	45°	1'-9"	3.1	8.2	0.78
	90°	2'-6"	4.3	8.5	2.08
	TEE or DE	2'-0"	3.6	7.1	1.23
24"	11 1/4°	2'-9"	2.8	2.4	0.37
	22 1/2°	4'-0"	4.0	3.5	1.1
	45°	4'-0"	4.5	5.0	1.78
	90°	5'-0"	4.5	10.0	4.46
	TEE or DE	4'-0"	5.0	7.2	2.86
30"	11 1/4°	4'-0"	4.0	4.0	1.27
	22 1/2°	5'-0"	5.0	5.5	2.72
	45°	6'-0"	6.5	8.0	6.18
	90°	6'-6"	7.0	15.0	13.52
	TEE or DE	6'-0"	7.0	12.0	9.98

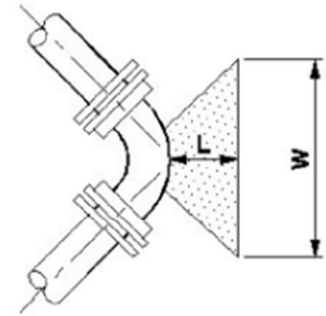

PLAN

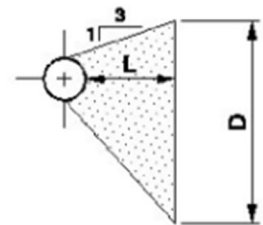

SECTION

TEST PRESSURE = 200 PSI
 SOIL BEARING PRESSURE = 2,000 PSF

TYPICAL DUCTILE IRON BLOCKING DETAIL

OFFICIAL PLAN HOLDER'S LIST

THE FOLLOWING PLAN HOLDER'S LIST IS THE ISGN-IN SHEET FOR THE MANDATORY PRE-BID MEETING WHICH WAS HELD ON FEBRUARY 15TH AT 1:00 PM AT THE PUBLIC WORKS MAIN OFFICE.

City of Dalton Public Works Department
Mandatory Pre-bid Meeting - WEST FRANKLIN STREET AND VALLEY DRIVE STORMWATER BYPASS SYSTEM
 Tuesday, November 5, 2024 - 1:00 PM

Sign-In Sheet

Name	Company	Phone	Email (Project Addenda will be sent to this address)
J. Galan Sheppard	City of Dalton - PW	706-508-3113	jshppard@daltonga.gov
Jeremy Reed	BS Reed Const	706-463-2009	Jeremy@bandjreedconstruction.com
Tim Fountain	Talley Construction	423-364-9814	TFountain@TalleyConstruction.net
Jorge Campos	Dalton - PW	706-280-2082	jcampos@daltonga.gov
Jaimeiah Whithead	Wright Brothers	423-241-7097	jwhithead@wbcci.com
Gatlin Jones	HD-Excavations + Util	678-836-3570	Gatlin@HD-excavations.com
Coby Stratton	H-Excavations + Utilite	678-761-3865	Coda@HD-excavations.com
Nathan Lee	Wilson Construction Management	478-451-6300	nathlee@wilsoncm.com
Desmond Mitchell	Here Rentals	423-889-2408	Desmond.Mitchell@HereRentals.com
Kyle Padgett	Here Rentals	423-230-8765	Kyle.padgett@HereRentals.com
Alex Vecchioni	Reynolds construction	248-830-3481	Kevin.Conkey@Reynoldscon.com
Heath Paige	CW Matthews	770-422-7520	hpaige@cwmatthews.com
Chad Towarsca	COD Public Works	706-278-7077	ctowarsca@daltonga.gov

City of Dalton Public Works Department
Mandatory Pre-bid Meeting - WEST FRANKLIN STREET AND VALLEY DRIVE STORMWATER BYPASS SYSTEM
 Tuesday, November 5, 2024 - 1:00 PM

Sign-In Sheet

Name	Company	Phone	Email (Project Addenda will be sent to this address)
Robbie Greene	Summers - Taylor	423-618-1588	robbie.g@summers-taylor.com

CONTRACT ADDENDUM

ADDENDA NO.: 002

DATE ISSUED: November 11th, 2024

BID DATE: November 20th, 2024

BID TIME: 2 PM ET

BID LOCATION: City of Dalton Finance Department

CONTRACTOR ACTION:

1. Acknowledge receipt of the first addendum by writing in "Addenda No. 1" on page 0200-3 of bid submission.
2. Acknowledge receipt of the first addendum by writing in "Addenda No. 2" on page 0200-3 of bid submission.
3. Please replace original bid form and revised bid form from Addenda No. 1 with the revised bid form included within this published addendum no.2.

CONTRACT CLARIFICATIONS

1. It has been discovered that revised bid form within published addendum no. 1 contained incorrect quantities. Revised bid form no. 2 has been included within this published addendum to reflect the correct quantities.
2. Revised bid form no. 2 includes a line item for tying in roof drains when encountered. Please refer to response to question 18 of interpretations within published addendum no. 1 for details pertaining to this line item.

REVISED BID FORM - ISSUED WITHIN ADDENDUM NO. 2
WEST FRANKLIN STREET AND VALLEY DRIVE STORMWATER BYPASS SYSTEM BID FORM
DALTON PROJECT NO. PW-2024-BD-161-2

ITEM	DESCRIPTION	UNITS	QTY	UNIT PRICE	TOTAL
General					
1	GENERAL CONDITIONS	LS	1		
2	PAYMENT & PERFORMANCE BONDING	LS	1		
3	CONSTRUCTION STAKING	LS	1		
4	MONITORING, NOI, NOT, RECORD KEEPING & REPORTING NPDES TO GA	LS	1		
5	OWNER-DIRECTED WORK	LS	1	\$ 50,000.00	
				SUBTOTAL	

DEMOLITION					
6	ASPHALT PAVEMENT FULL DEPTH REMOVAL (TRENCH LIMITS)	SY	685		
7	1.5" FULL WIDTH PAVEMENT MILLING	SY	2,361		
8	CONCRETE DRIVEWAY REMOVAL	SY	120		
9	ASPHALT DRIVEWAY REMOVAL	SY	15		
10	CURB & GUTTER REMOVAL	LF	299		
11	REMOVE 8" SANITARY SEWER PIPE	LF	137		
12	REMOVE 10" SANITARY SEWER PIPE	LF	25		
13	REMOVE EXISTING SANITARY SEWER MANHOLE	EA	1		
14	REMOVE AND REPLACE LANDSCAPE WALL AND WOODEN BRIDGE	LS	1		
15	ABANDON IN PLACE 30" RCP	LF	22		
16	ABANDON IN PLACE 15" RCP	LF	30		
17	REMOVE 36" RCP	LF	135		
18	REMOVE 15" RCP	LF	27		
19	REMOVE JUNCTION BOX/CATCH BASIN/DROP INLET	EA	7		
20	RELOCATE EXISTING WATER MAIN	EA	3		
21	TREE REMOVAL (705/707 VALLEY DRIVE)	EA	1		
22	RELOCATE POWER POLE, GUY WIRE, AND ELECTRIC BOX	LS	1		
23	REMOVE AND REPLACE FENCE	LF	245		
24	MISC. CLEARING & GRUBBING (AS REQUIRED PROJECT WIDE)	LS	1		
				SUBTOTAL	

DRAINAGE SYSTEM					
25	CUSTOM STRUCTURE (A-14)	EA	1		
26	CUSTOM STRUCTURES (A-13, A-12, A-11 & A-10)	EA	4		
27	REDI-ROCK WALL (OR APPROVED EQUAL)	LF	57		
28	ORNAMENTAL FENCE	LF	57		
29	CATCH BASIN (GDOT 1019AP TYPE E)	EA	5		
30	CATCH BASIN/DROP INLET (GDOT 1019AP TYPE A)	EA	2		
31	HEADWALL (CUSTOM)	EA	2		
32	STORM MANHOLE (GDOT 1011A)	EA	7		
33	6'X5' BOX CULVERT	LF	248		
34	48" CLASS III RCP	LF	285		
35	42" CLASS III RCP	LF	890		
36	36" CLASS III RCP	LF	36		
37	18" CLASS V RCP	LF	19		
38	HDPE ROOF DRAIN CONFLICT CONNECTION	LF	100		
				SUBTOTAL	

SANITARY SEWER					

38	SANITARY SEWER DOGHOUSE MANHOLE - 4-FT DIA.	EA	2		
39	SANITARY SEWER MANHOLE	EA	1		
40	REHABILITATE EXISTING SANITARY SEWER MANHOLE	VF	8		
41	8" DIP	LF	147		
42	10" DIP	LF	25		
43	BOLT-DOWN WATER-TIGHT COVER	EA	2		
44	BOLT-DOWN NON WATER-TIGHT COVER	EA	1		
45	CONCRETE ENCASEMENT	LF	25		
				SUBTOTAL	

ROADWAY					
46	CURB & GUTTER	LF	299		
47	TEMPORARY GAB AT TRENCH CAP	TN	210		
48	FULL WIDTH ASPHALT OVERLAY - (1.5" TP 2 GP1) VALLEY DR.	TN	105		
49	FULL WIDTH ASPHALT OVERLAY (1.5" TP 1 GP1) - FRANKLIN DR.	TN	158		
50	ASPHALT PAVING (TRENCH LIMITS) (8" GAB, 2" 19MM) - VALLEY DR	SY	245		
51	ASPHALT PAVING (TRENCH LIMITS) (6" GAB, 2" 19MM) - W FRANKLIN	SY	440		
52	CONCRETE DRIVEWAY REPAIR PAVING	SY	120		
53	FINE GRADING	LS	1		
54	ASPHALT DRIVEWAY REPAIR PAVING	SY	15		
				SUBTOTAL	

SITE RESTORATION & EROSION CONTROL					
55	CONSTRUCTION EXIT/ENTRANCE	EA	2		
56	RIPRAP (INSTALLED)	SY	100		
57	TN FIELD STONE (9" - D50)	SY	60		
58	TURF GRASS SEEDING	SY	3,195		
59	SILT FENCE	LF	1,010		
60	ROCK FILTER DAM	EA	4		
61	CURB INLET PROTECTION (SD2P)	EA	6		
62	FABRIC INLET PROTECTION (SD2F)	EA	9		
63	GRADING COMPLETE	LS	1		
64	DUST CONTROL (DU)	LS	1		
				SUBTOTAL	

MISCELLANEOUS					
65	TRAFFIC CONTROL	LS	1		
66	UTILITY CONFLICTS & TEMPORARY SERVICE	LS	1		
67	UNSUITABLE SOILS ALLOWANCE (REMOVAL & REPLACEMENT)*	CY	200		
68	ROCK EXCAVATION*	CY	200		
				SUBTOTAL	

*PROVIDE UNIT PRICE

Company Name: _____

Authorized Bid Rep. Signature: _____

Authorized Bid Rep. Title: _____

TOTAL

ADVERTISEMENT FOR BID

**WEST FRANKLIN STREET AND VALLEY DRIVE STORMWATER BYPASS SYSTEM
DALTON PROJECT NO. PW-2024-BD-161-2**

Sealed bids will be received by the City of Dalton Finance Department located at 300 W. Waugh Street, Dalton, Georgia 30720 until:

WEDNESDAY, NOVEMBER 20, 2024 AT 2:00 PM

for the furnishing of all materials, labor, tools, skill, equipment and incidentals unless noted otherwise for the construction of the project entitled:

**WEST FRANKLIN STREET AND VALLEY DRIVE STORMWATER BYPASS SYSTEM
DALTON PROJECT NO. PW-2024-BD-161-2**

at which time and place the sealed bids will be publicly opened and read aloud.

Bids received after the designated time will not be considered.

The principal items of construction include:

The Contractor will be responsible for installing a 42" stormwater pipe system on the right-of-way, and off the right-of-way where drainage easements have been obtained on W. Franklin Street and Valley Drive in the City of Dalton. The work includes, but is not limited to, curb and gutter demolition, trench excavation, and installation of: custom stormwater structures, approximately 1,175 ft. of 42" and 48" RCP, 248 ft. of box culverts, approximately 230 ft. of RCP and DIP of various sizes, stormwater manholes, catch basins, and a custom headwall. The Contractor will mill and overlay the full width of W. Franklin St. and Valley Dr. within the limits of disturbance after completing the stormwater bypass system construction. The work shall be done as directed by the plans developed by Arcadis-U.S., Inc. All work shall be performed according to the latest Georgia D.O.T. Standards and Specifications.

Bidders shall inform themselves of and comply with all conditions and specifications contained in the bid package, contract, related documents and State and Federal Law. The bid package, specifications, and contract documents for this project are open to public inspection at the City of Dalton Public Works Department located at 535 Elm Street, Dalton, Georgia 30721. The Public Works Department may be contacted by telephone at (706) 278-7077 or by mail at P.O. Box 1205, Dalton, Georgia 30722.

A **Mandatory** pre-bid meeting is scheduled for **1:00 PM Tuesday, November 5, 2024** to begin at the Public Works Office. Please reserve time to tour the site location. Failure to attend the mandatory pre-bid meeting will result in disqualification of bid.

Any questions pertaining to the bid documents and specifications should be submitted in

writing via email by the **questions deadline of 5:00 PM November 7, 2024**. Questions must be directed to Jackson Sheppard at: jsheppard@daltonga.gov.

The City of Dalton will issue responses to questions and any other corrections or amendments it deems necessary in written addenda issued prior to the bids due date. Bidders are advised to check the website for addenda before submitting a bid.

One Contract shall be awarded covering all work, and the contract duration shall be 24 weeks from notice to proceed. Bidders must agree to pay as liquidated damages the sum of \$300.00 per each consecutive calendar day thereafter. Due consideration will be given to delivery of materials in specifying starting date.

Contract documents, plans, and the bid package for this project may be obtained electronically via the City of Dalton's webpage <http://www.daltonga.gov/rfps>.

The Project "Bidder's List" will consist of the bidders on the sign-in sheet from the mandatory pre-bid meeting.

Bids must be accompanied by a Certified Check or Bid Bond in an amount equal to not less than five percent (5%) of the bid to be considered.

No bid may be withdrawn after the scheduled closing time for receiving bids for a period of sixty (60) days.

The Owner reserves the right to reject any or all bids (and/or alternates) and to waive formalities and re-advertise.

CITY OF DALTON, GEORGIA

BY _____
T. Jackson Sheppard, E.I.T.
Project Manager

###

TABLE OF CONTENTS

	<u>PAGE</u>
<u>SECTION 0100 – INFORMATION FOR BIDDERS</u>	
RECEIPT AND OPENING OF BIDS	0100-1
PREPARATION OF BID	0100-1
ELECTRONIC MAIL MODIFICATION	0100-2
QUALIFICATIONS OF BIDDERS	0100-2
BID SECURITY	0100-2
LIQUIDATED DAMAGES AND FAILURE TO ENTER INTO CONTRACT	0100-3
TIME OF COMPLETION AND LIQUIDATED DAMAGES.....	0100-3
CONDITION OF WORK.....	0100-3
ADDENDA AND INTERPRETATIONS	0100-3
SECURITY FOR FAITHFUL PERFORMANCE	0100-4
POWER OF ATTORNEY	0100-4
NOTICE OF SPECIAL CONDITIONS.....	0100-4
LAWS AND REGULATIONS.....	0100-4
METHOD OF AWARD	0100-4
OBLIGATION OF BIDDER.....	0100-5
CORRELATION AND INTENT OF DOCUMENTS	0100-5
CLAIMS.....	0100-5
ORDER OF WORK.....	0100-5
SUBCONTRACTS	0100-5
TIMELY EXECUTION	0100-6
<u>SECTION 0200 – BID PROPOSAL</u>	
BID BOND.....	0200-1
BID PROPOSAL	0200-3
CONSTRUCTION PAYMENT BOND	0200-6
CONSTRUCTION PERFORMANCE BOND.....	0200-11
CONTRACT	0200-16
E-VERIFY AFFIDAVIT	0200-18
<u>SECTION 0300 – GENERAL CONDITIONS</u>	
CONTRACT AND CONTRACT DOCUMENTS	0300-1
DEFINITIONS	0300-1
Contractor	0300-1
Contract.....	0300-1

	<u>PAGE</u>
Project Representative	0300-1
Owner	0300-1
Subcontractor.....	0300-1
Work on (at) the Project.....	0300-1
CORRELATION AND INTENT OF DOCUMENTS.....	0300-1
MATERIALS, SERVICES AND FACILITIES	0300-2
CONTRACTOR'S TITLE TO MATERIALS	0300-2
MATERIALS FURNISHED BY THE CONTRACTOR.....	0300-2
INSPECTION AND TESTING OF MATERIALS	0300-3
PATENTS	0300-3
SURVEYS, PERMITS AND REGULATIONS	0300-3
CONTRACTOR'S OBLIGATIONS.....	0300-4
CONTRACTOR'S RESPONSIBILITY.....	0300-4
WEATHER CONDITIONS	0300-4
SAFETY PROVISIONS	0300-5
SANITARY PROVISIONS	0300-5
PUBLIC CONVENIENCE AND SAFETY.....	0300-5
PROTECTION OF WORK AND PROPERTY – EMERGENCY	0300-5
INSPECTION.....	0300-6
REPORTS, RECORDS AND DATA	0300-6
SUPERINTENDENCE BY CONTRACTOR.....	0300-6
COMPETENT LABOR.....	0300-6
CONSTRUCTION EQUIPMENT	0300-7
CHANGES IN THE WORK.....	0300-7
CHANGE IN CONTRACT PRICE.....	0300-8
CHANGE OF THE CONTRACT TIME.....	0300-11
CORRECTION OF WORK	0300-12
EXISTING UNDERGROUND UTILITIES AND STRUCTURES	0300-12
SUBSURFACE CONDITIONS FOUND DIFFERENT.....	0300-13
CLAIMS FOR EXTRA WORK.....	0300-13
RIGHT OF THE OWNER TO TERMINATE CONTRACT.....	0300-13
CONSTRUCTION SCHEDULE AND PERIODIC ESTIMATES.....	0300-13
PAYMENTS TO CONTRACTORS	0300-14
ACCEPTANCE AND FINAL PAYMENT	0300-16
PAYMENTS BY CONTRACTORS	0300-16
CONTRACTOR'S AND SUBCONTRACTOR'S INSURANCE.....	0300-17
CONTRACT SECURITY.....	0300-21
ADDITIONAL OR SUBSTITUTE BOND.....	0300-21

	<u>PAGE</u>
LIEN.....	0300-21
ASSIGNMENTS.....	0300-22
MUTUAL RESPONSIBILITY OF CONTRACTORS.....	0300-22
COORDINATION WITH OTHER CONTRACTORS	0300-22
SUBCONTRACTING.....	0300-22
USE OF PREMISES AND REMOVAL OF DEBRIS	0300-23
QUANTITIES OF ESTIMATE	0300-24
RIGHTS-OF-WAY AND SUSPENSION OF WORK	0300-24
GUARANTY.....	0300-24
CONFLICTING CONDITIONS.....	0300-25
NOTICE AND SERVICE THEREOF.....	0300-25
PROVISIONS REQUIRED BY LAW DEEMED INSERTED	0300-25
SUSPENSION OF WORK.....	0300-25
PROTECTION AND RESTORATION OF PROPERTY.....	0300-25
RESPONSIBILITY FOR DAMAGE CLAIMS.....	0300-26
INTEREST OF FEDERAL, STATE OR LOCAL OFFICIALS	0300-26
OTHER PROHIBITED INTERESTS	0300-27
USE OF CHEMICALS	0300-27
MAINTENANCE OF TRAFFIC	0300-27
ACCEPTANCE OF FINAL PAYMENT CONSTITUTES RELEASE.....	0300-27
OWNER'S RIGHT TO SUSPEND WORK	0300-27
TIME FOR COMPLETION AND LIQUIDATED DAMAGES.....	0300-28
AFFIDAVIT FOR FINAL PAYMENT AND RELEASE OF LIENS FORM.....	0300-30

SECTION 0400 – GENERAL NOTES

EXHIBIT A – ARCADIS U.S., INC. SITE DEVELOPMENT PLANS DATED OCTOBER 2024



SECTION 0100 – INFORMATION FOR BIDDERS

0101 RECEIPT AND OPENING OF BIDS

The CITY OF DALTON, GEORGIA (*hereinafter called the Owner*), invites bids on the form attached hereto, all blanks of which must be appropriately filled in. Bids will be received by the Owner at the CITY OF DALTON FINANCE DEPARTMENT
300 W. WAUGH STREET, DALTON, GEORGIA 30720 until NOVEMBER 20TH, 2024, AT 2:00 PM and then at said office publicly opened and read aloud. The envelope containing the bids must be sealed and designated as the bid for the construction of the project entitled:

**WEST FRANKLIN STREET AND VALLEY DRIVE STORMWATER BYPASS SYSTEM
DALTON PROJECT NO. PW-2024-BD-161-2**

The Owner may consider informal any bid not prepared and submitted in accordance with the provisions hereof and may waive any informalities to reject any and all bids. Any bid may be withdrawn prior to the above scheduled time for opening of bids or authorized postponement thereof. Any bid received after the time and date specified shall not be considered. No bidder may withdraw a bid within 60 days after the actual date of the opening thereof.

0102 PREPARATION OF BID

Each bid must be submitted on the prescribed form. All blank spaces for bid prices must be filled in, in ink or typewritten, in numerals for unit prices and for total amounts.

Each bid must be submitted in a sealed envelope bearing on the outside the name of the bidder, his address, and the name of the project for which the bid is submitted. In accordance with State Law (O.C.G.A 13-10-91 & 50-36), **ALL SEALED BIDS MUST INCLUDE AN EXECUTED E-VERIFY AFFIDAVIT, THIS DOCUMENT CAN BE FOUND IN THE BID PROPOSAL SECTION.** If forwarded by mail, the sealed envelope containing the bid must be enclosed in another envelope addressed as specified in the bid form. Any bid which is not properly prepared and accompanied by required certifications may be rejected by the Owner.

Each bidder will be required to certify compliance with the Immigration Reform and Control Act of 1986 (IRCA), D.L. 99-603 and the Georgia Security and Immigration Compliance Act O.C.G.A. §13-10-90 et seq. by doing the following: registering at <https://www.uscis.gov/e-verify> to verify information of all newly hired employees in order to comply with the Immigration Reform and Control Act of 1986 (IRCA), D.L. 99-603 and the Georgia Security and Immigration Compliance Act. Each firm must submit a completed and notarized E-verify (Exhibit A) affidavit with their bid submittal. During the entire duration of this contract, Contractor and all sub-contractors must remain in compliance with Georgia Security and Immigration Compliance Act of 2007 and Georgia code §13-10-91 and §50-36-1.

0103 ELECTRONIC MAIL MODIFICATION

Any bidder may modify his bid by written electronic communication at any time prior to the scheduled closing time for receipt of bids, provided such communication is received by the Owner prior to the closing time, and, provided further, the Owner is satisfied that a written confirmation of the electronic modification over the signature of the bidder was mailed prior to the closing time. If written confirmation is not received within two days from the closing time, no consideration will be given to the electronically mailed modification.

0104 QUALIFICATIONS OF BIDDERS

The Owner may make such investigations as he deems necessary to determine the ability of the bidder to perform the work, and the bidder shall furnish to the Owner all such information and data for this purpose as the Owner may request. By submission of his Bid, the Bidder acknowledges the right of the Owner to make such investigations, to contact references and utilize this information as a basis of determining award of the contract. The Owner reserves the right to reject any bid if the evidence submitted by, or investigation of, such bidder fails to satisfy the Owner that such bidder is properly qualified to carry out the obligations of the contract and to complete the work contemplated therein. Conditional bids will not be accepted.

Written information pertaining to the Bidder's qualifications may be requested by the Owner. Failure of the Bidder to provide such information within fifteen days of notification will be grounds for disqualification.

0105 BID SECURITY

Each bid must be accompanied by a certified check or bid bond prepared on the form of bid bond attached hereto, duly executed by the bidder as principal and having as surety thereon a surety company approved by the Owner, in the amount of five (5)% of the bid. Such certified checks or bid bonds will be returned to all except the three lowest bidders within three days after the opening of bids, and the remaining certified checks or bid bonds will be returned promptly after the Owner

and the accepted bidder have executed the contracts, or, if no award has been made within 60 days after the date of the opening of bids, upon demand of the bidder at any time thereafter, so long as he has not been notified of the acceptance of his bid.

0106 LIQUIDATED DAMAGES AND FAILURE TO ENTER INTO CONTRACT

The successful bidder, upon his failure or refusal to execute and deliver the contract and bonds required within 10 days after he has received notice of the acceptance of his bid, shall forfeit to the Owner, as liquidated damages for such failure or refusal, the security (bid bond) deposited with his bid.

0107 TIME OF COMPLETION AND LIQUIDATED DAMAGES

Bidder must agree to commence work on or before a date to be specified in a written "Notice to Proceed" of the Owner and to fully complete the project within 24 weeks following "Notice to Proceed". Bidders must agree also to pay as liquidated damages the sum of \$300.00 per each consecutive calendar day thereafter. Anticipated "Notice to Proceed" date is tentatively set for the week of December 16, 2024.

0108 CONDITION OF WORK

Each bidder must inform himself fully of the conditions relating to the construction of the project and the employment of labor thereon. Failure to do so will not relieve a successful bidder of his obligation to furnish all material and labor necessary to carry out the provisions of his contract. Insofar as possible the Contractor, in carrying out his work, must employ such methods or means as will not cause any interruption of or interference with the work of any other contractor.

0109 ADDENDA AND INTERPRETATIONS

Oral interpretations of the meaning of plans, specifications or other contract documents shall not be binding over written material.

Every request for such interpretation should be in writing addressed to City of Dalton Public Works, P.O. Box 1205, Dalton, Georgia 30722 or by email to Jackson Sheppard (jsheppard@daltonga.gov) and to be given consideration must be received by the question's deadline of 5:00 PM November 7, 2024. Any and all such interpretations and any supplemental instructions will be in the form of written addenda to the specifications, which, will be emailed to all prospective bidders. Failure of any bidder to receive any such addendum or interpretations shall not relieve such bidder from any obligation under his bid as submitted. All addenda so issued shall become part of the contract documents.

0110 SECURITY FOR FAITHFUL PERFORMANCE

Simultaneously with his delivery of the executed contract, the Contractor shall furnish a surety bond or bonds as security for faithful performance of his contract and for the payment of all persons performing labor on the project under this contract, and furnishing materials in connection with his contract, as specified in the General Conditions included herein. Surety companies executing Bonds must appear on the Treasury Department's most current list (*Circular 570 as amended*) and be authorized to transact business in the state where the project is located.

0111 POWER OF ATTORNEY

Attorneys-in-fact who sign bid bonds or contract bonds must file with each bond a certified and effectively dated copy of their power of attorney.

0112 NOTICE OF SPECIAL CONDITIONS

Attention is particularly called to those parts of the contract documents and specifications which are identified subsequently under Special Conditions.

0113 LAWS AND REGULATIONS

The bidders' attention is directed to the fact that all applicable federal and state laws, municipal ordinances, and the rules and regulations of all authorities having jurisdiction over construction of the project shall apply to the contract throughout, and they will be deemed to be included in the contract the same as though herein written out in full.

0114 METHOD OF AWARD

If the Contract is awarded, it will be awarded to the lowest Bidder whose evaluation by Owner indicates to Owner that the award will be in the best interests of the project. The Owner shall have complete discretion in making this determination and may consider factors such as, but not limited to the following:

0114.01 Unit bid prices of various items as they relate to total bid price.

0114.02 Proximity of the Bidder's permanent place of business as it may relate to Bidder's responsiveness in carrying out the contract.

0114.03 Litigation record of the Bidder.

0114.04 Satisfactory completion of similar projects.

- 0114.05 Resources pertaining to management, personnel and equipment.
- 0114.06 Financial history, credit rating and current resources.

0115 OBLIGATION OF BIDDER

At the time of the opening of bids, each bidder will be presumed to have inspected the site and to have read and to be thoroughly familiar with the plans and contract documents (*including all addenda*). The failure or omission of any bidder to examine any form, instrument, or document shall in no way relieve any bidder from any obligation in respect to his bid.

0116 CORRELATION AND INTENT OF DOCUMENTS

The contract documents are complementary, and what is called for by one shall be as binding as if called for by all.

The intent of the documents is to describe in detail all construction entailed in this project. The contractor will furnish all labor, materials, equipment, transportation, tools and appurtenances such as may be reasonably required under the terms of the contract to make each part of the work complete.

The drawings are intended to conform and agree with the specifications. If, however, discrepancies occur, the Owners will decide which shall govern. Special specifications stated on the drawings govern that particular piece of construction and have equal weight and importance as the printed specifications. In the event of any discrepancies between the drawings and the figures written thereon, the figures are to be taken as correct.

0117 CLAIMS

The Owner reserves the right to refuse to issue any voucher and to direct that no payment shall be made the contractor in the case they have reason to believe that said contractor has neglected or failed to pay any subcontractor, material dealer, worker or employee for work performed on or about the project including work as set forth in these specifications, until the Owner is satisfied that such subcontractors, material dealers, worker, or employees have been fully paid. However this provision shall not obligate the Owner to intervene in any claim.

0118 ORDER OF WORK

The work shall be started at such points as the Owner shall designate and shall be prosecuted in the order he directs. This applies to both location and items of construction.

0119 SUBCONTRACTS

If required by the Owner, the apparent Successful Bidder, and any other Bidder so requested, will within seven days after the day of the Bid opening submit to Owner a list of all Subcontractors and other persons and organizations (*including those who are to furnish the principal items of material and equipment*) proposed for those portions of the Work as to which such identification is so required. If the Owner, after due investigation, has reasonable objection to any proposed Subcontractor, other person or organization, may, before giving the Notice of Award, request the apparent Successful Bidder to submit an acceptable substitute without an increase in Bid price. If the apparent Successful Bidder declines to make any such substitution, the contract shall not be awarded to such Bidder, but his declining to make any such substitution will not constitute grounds for sacrificing his Bid Security. Any Subcontractor, other person or organization so listed and to whom the Owner does not make written objection prior to the giving of the Notice of Award will be deemed acceptable to Owner.

0120 TIMELY EXECUTION

When the Owner gives a Notice of Award to the Successful Bidder, it will be accompanied by at least five unsigned counterparts of the Agreement and all other Contract Documents. Within ten days thereafter, the Contractor shall sign and deliver at least five counterparts of the Agreement to Owner with all other Contract Documents attached. Thereafter, the Owner will deliver two fully signed counterparts to Contractor.

..... END OF SECTION



WEST FRANKLIN STREET AND VALLEY DRIVE STORMWATER BYPASS SYSTEM
DALTON PROJECT NO. PW-2024-BD-161-2

SECTION 0200 – BID PROPOSAL

BID BOND
(Five Percent of Bid)

KNOW ALL MEN BY THESE PRESENTS, that we, the undersigned _____
Wright Brothers Construction Company, Inc.

of the City of Charleston State of Tennessee and County of Bradley
as Principal and Liberty Mutual Insurance Company

as Surety, are hereby held and firmly bound unto the CITY OF DALTON, GEORGIA as
Owner in the penal sum of Five Percent of Amount Bid-----
Dollars (\$ -----5%-----) for the payment of which, well and truly to be made,
we hereby jointly and severally bind ourselves, our heirs, executors, administrators,
successors and assigns.

Signed this 14th day of November, 2024.

The condition of the above obligation is such that whereas the Principal has submitted to
the CITY OF DALTON, GEORGIA a certain bid attached hereto and hereby made a part
hereof to enter into a contract in writing for the construction of the project entitled:

WEST FRANKLIN STREET AND VALLEY DRIVE STORMWATER BYPASS SYSTEM
DALTON PROJECT NO. PW-2024-BD-161-2

NOW, THEREFORE,

- (a) If said bid shall be rejected or in the alternate,
- (b) If said bid shall be accepted and the Principal shall execute and deliver a contract
in the Form of Contract attached hereto (*properly completed in accordance with
said bid*) and shall furnish a bond for his faithful performance of



BID BOND
(Continued)

said contract and for the payment of all persons performing labor or furnishing materials in connection therewith, and shall in all other respects perform the agreement created by the acceptance of said bid, then this obligation shall be void; otherwise the same shall remain in force and effect; it being expressly understood and agreed that the liability of the surety for any and all claims hereunder shall, in no event, exceed the penal amount of this obligation as herein stated.

The Surety, for value received, hereby stipulates and agrees that the obligations of said Surety and its bond shall be in no way impaired or affected by any extension of the time within which the Owner may accept such Bids, and said Surety does hereby waive notice of any such extension.

IN WITNESS WHEREOF, the Principal and the Surety have hereunto set their hands and seals, and such of them as are corporations have caused their corporate seals to be hereto affixed and these presents to be signed by their proper officers, the day and year first set forth above.

Don W. Ryfel
Witness As To Principal

Wright Brothers Construction Company, Inc.

Principal

By *J. Mitchell Simpson* SEAL
J. Mitchell Simpson - Exec. V.P.

Camille M. Cruz
Witness As To Surety
Camille M. Cruz, Surety Witness

Liberty Mutual Insurance Company

Surety

175 Berkeley Street
Boston, MA 02116

Address

By *Gicelle Pajon* SEAL
Attorney-in-Fact - Gicelle Pajon





POWER OF ATTORNEY

Certificate No: 8204866

Liberty Mutual Insurance Company
The Ohio Casualty Insurance Company
West American Insurance Company

KNOWN ALL PERSONS BY THESE PRESENTS: That The Ohio Casualty Insurance Company is a corporation duly organized under the laws of the State of New Hampshire, that Liberty Mutual Insurance Company is a corporation duly organized under the laws of the State of Massachusetts, and West American Insurance Company is a corporation duly organized under the laws of the State of Indiana (herein collectively called the "Companies"), pursuant to and by authority herein set forth, does hereby name, constitute and appoint, Gicelle Pajon all of the city of

Sunrise, state of Florida each individually if there be more than one named, its true and lawful attorney-in-fact to make, execute, seal, acknowledge and deliver, for and on its behalf as surety and as its act and deed, any and all undertakings, bonds, recognizances and other surety obligations, in pursuance of these presents and shall be as binding upon the Companies as if they have been duly signed by the president and attested by the secretary of the Companies in their own proper persons.

IN WITNESS WHEREOF, this Power of Attorney has been subscribed by an authorized officer or official of the Companies and the corporate seals of the Companies have been affixed thereto this 1st day of July, 2024.

Liberty Mutual Insurance Company
The Ohio Casualty Insurance Company
West American Insurance Company



By:

Nathan J. Zangerle, Assistant Secretary

STATE OF PENNSYLVANIA ss
COUNTY OF MONTGOMERY

On this 1st day of July, 2024, before me personally appeared Nathan J. Zangerle, who acknowledged himself to be the Assistant Secretary of Liberty Mutual Insurance Company, The Ohio Casualty Company, and West American Insurance Company, and that he, as such, being authorized so to do, execute the foregoing instrument for the purposes therein contained by signing on behalf of the corporations by himself as a duly authorized officer.

IN WITNESS WHEREOF, I have hereunto subscribed my name and affixed my notarial seal at Plymouth Meeting, Pennsylvania, on the day and year first above written.



Commonwealth of Pennsylvania - Notary Seal
Teresa Pastella, Notary Public
Montgomery County
My commission expires March 28, 2025
Commission number 1126044
Member, Pennsylvania Association of Notaries

By:

Teresa Pastella, Notary Public

This Power of Attorney is made and executed pursuant to and by authority of the following By-laws and Authorizations of The Ohio Casualty Insurance Company, Liberty Mutual Insurance Company, and West American Insurance Company which resolutions are now in full force and effect reading as follows:

ARTICLE IV – OFFICERS: Section 12. Power of Attorney.

Any officer or other official of the Corporation authorized for that purpose in writing by the Chairman or the President, and subject to such limitation as the Chairman or the President may prescribe, shall appoint such attorneys-in-fact, as may be necessary to act in behalf of the Corporation to make, execute, seal, acknowledge and deliver as surety any and all undertakings, bonds, recognizances and other surety obligations. Such attorneys-in-fact, subject to the limitations set forth in their respective powers of attorney, shall have full power to bind the Corporation by their signature and execution of any such instruments and to attach thereto the seal of the Corporation. When so executed, such instruments shall be as binding as if signed by the President and attested to by the Secretary. Any power or authority granted to any representative or attorney-in-fact under the provisions of this article may be revoked at any time by the Board, the Chairman, the President or by the officer or officers granting such power or authority.

ARTICLE XIII - Execution of Contracts: Section 5. Surety Bonds and Undertakings.

Any officer of the Company authorized for that purpose in writing by the chairman or the president, and subject to such limitations as the chairman or the president may prescribe, shall appoint such attorneys-in-fact, as may be necessary to act in behalf of the Company to make, execute, seal, acknowledge and deliver as surety any and all undertakings, bonds, recognizances and other surety obligations. Such attorneys-in-fact, subject to the limitations set forth in their respective powers of attorney, shall have full power to bind the Company by their signature and execution of any such instruments and to attach thereto the seal of the Company. When so executed such instruments shall be as binding as if signed by the president and attested by the secretary.

Certificate of Designation – The President of the Company, acting pursuant to the Bylaws of the Company, authorizes Nathan J. Zangerle, Assistant Secretary to appoint such attorneys-in-fact as may be necessary to act on behalf of the Company to make, execute, seal, acknowledge and deliver as surety any and all undertakings, bonds, recognizances and other surety obligations.

Authorization – By unanimous consent of the Company's Board of Directors, the Company consents that facsimile or mechanically reproduced signature of any assistant secretary of the Company, wherever appearing upon a certified copy of any power of attorney issued by the Company in connection with surety bonds, shall be valid and binding upon the Company with the same force and effect as though manually affixed.

I, Renee C. Llewellyn, the undersigned, Assistant Secretary, of Liberty Mutual Insurance Company, The Ohio Casualty Insurance Company, and West American Insurance Company do hereby certify that this power of attorney executed by said Companies is in full force and effect and has not been revoked.

IN TESTIMONY WHEREOF, I have hereunto set my hand and affixed the seals of said Companies this 14th day of November, 2024.



By:

Renee C. Llewellyn, Assistant Secretary

Not valid for mortgage, note, loan, letter of credit, currency rate, interest rate or residual value guarantees.

For bond and/or Power of Attorney (POA) verification inquiries, please call 610-832-8240 or email HOSUR@libertymutual.com.

BID PROPOSAL

Place Signed in Charleston, TN

Date 11/20/2024

Proposal of Wright Brothers Construction Company, Inc. (*hereinafter called "Bidder"*) a contractor organized and existing under the laws of the City of Charleston State of Tennessee and County of Bradley, * an individual, a corporation, or a partnership doing business as Wright Brothers Construction Company, Inc.

TO: CITY OF DALTON, GEORGIA
(*Hereinafter called "Owner"*)

Gentlemen:

The Bidder in compliance with your invitation for bids for the construction of the WEST FRANKLIN STREET AND VALLEY DRIVE STORMWATER BYPASS SYSTEM (DALTON PROJECT NO. PW-2024-BD-161-2) having examined the plans and specifications with related documents and the site of the proposed work, and being familiar with all of the conditions surrounding the construction of the proposed project, including the availability of materials and labor, hereby proposes to furnish all labor, materials, and supplies, and to construct the project in accordance with the contract documents, within the time set forth herein, and at the prices stated below. These prices are to cover all expenses incurred in performing the work required under this contract, of which this proposal is a part.

Bidder hereby agrees to commence work under this contract on or before a date to be specified in a written "Notice to Proceed" of the Owner and to fully complete the project within 24 weeks following "Notice to Proceed". Bidder further agrees to pay as liquidated damages the sum of \$300.00 for each consecutive calendar day thereafter as hereinafter provided in the General Conditions under "Time of Completion and Liquidated Damages."

Bidder acknowledges receipt of the following addenda:

Addenda No. 1

Addenda No. 2

*Strike out inapplicable terms



BID PROPOSAL
(Continued)

Amount shall be shown in figures.

The prices submitted shall include all labor, materials, removal, overhead, profit, insurance, etc., to cover the finished work of the several kinds called for.

Bidder understands that the Owner reserves the right to reject any or all bids and to waive any informalities in the bidding.

The Bidder agrees that this bid shall be good and may not be withdrawn for a period of 60 calendar days after the scheduled closing time for receiving bids.

The undersigned further agrees that, in case of failure on his part to execute said contract and bond within ten (10) days after the award thereof, the check or bond accompanying his bid and the money payable thereon shall become the property of the Owner; otherwise, the check or bond accompanying this proposal shall be returned to the Bidder.

The Bidder declares that he understands that the quantities shown on the proposal are subject to adjustment by either increase or decrease, and that should the quantities of any of the items of work be increased, the undersigned proposes to do the additional work at the unit prices stated herein; and should the quantities be decreased, he also understands that payment will be made on actual quantities at the unit price bid and will make no claim for anticipated profits for any decrease in the quantities and that actual quantities will be determined upon completion of work, at which time adjustment will be made to the contract amount by direct increase or decrease.

Attached hereto is a bid bond or certified check on the 20th of November in the amount of 5% of bid amount according to conditions under "Information for Bidders" and the provisions therein.

The full name and residence of persons or parties interested in the foregoing bids, as principals, are named as follows:

Stephen D. Wright - President - 9022 Mouse Creek Road, Cleveland, Bradley Co., TN 37312

J. Mitchell Simpson - Executive Vice President - 1845 Rabbit Valley Road, NW, Cleveland, Bradley Co., TN 37312

Anthony P. Boals - Vice President - 2302 Wood Sorrell Lane, Signal Mountain, Hamilton Co., TN 37377

BID PROPOSAL
(Continued)

Dated at:

Signed in Charleston, TN

The 20th day of November, 2024

J. Mitchell Simpson

Principal

By



SEAL

REVISED BID FORM - ISSUED WITHIN ADDENDUM NO. 2
WEST FRANKLIN STREET AND VALLEY DRIVE STORMWATER BYPASS SYSTEM BID FORM
DALTON PROJECT NO. PW-2024-BD-161-2

ITEM	DESCRIPTION	UNITS	QTY	UNIT PRICE	TOTAL
General					
1	GENERAL CONDITIONS	LS	1	\$180,000.00	\$180,000.00
2	PAYMENT & PERFORMANCE BONDING	LS	1	\$14,245.00	\$14,245.00
3	CONSTRUCTION STAKING	LS	1	\$15,800.00	\$15,800.00
4	MONITORING, NOI, NOT, RECORD KEEPING & REPORTING NPDES TO GA	LS	1	\$5,400.00	\$5,400.00
5	OWNER-DIRECTED WORK	LS	1	\$ 50,000.00	\$50,000.00
				SUBTOTAL	\$265,445.00

DEMOLITION					
6	ASPHALT PAVEMENT FULL DEPTH REMOVAL (TRENCH LIMITS)	SY	685	\$8.00	\$5,480.00
7	1.5" FULL WIDTH PAVEMENT MILLING	SY	2,361	\$9.00	\$21,249.00
8	CONCRETE DRIVEWAY REMOVAL	SY	120	\$20.00	\$2,400.00
9	ASPHALT DRIVEWAY REMOVAL	SY	15	\$57.00	\$855.00
10	CURB & GUTTER REMOVAL	LF	299	\$10.00	\$2,990.00
11	REMOVE 8" SANITARY SEWER PIPE	LF	137	\$43.00	\$5,891.00
12	REMOVE 10" SANITARY SEWER PIPE	LF	25	\$46.00	\$1,150.00
13	REMOVE EXISTING SANITARY SEWER MANHOLE	EA	1	\$1,875.00	\$1,875.00
14	REMOVE AND REPLACE LANDSCAPE WALL AND WOODEN BRIDGE	LS	1	\$18,000.00	\$18,000.00
15	ABANDON IN PLACE 30" RCP	LF	22	\$124.00	\$2,728.00
16	ABANDON IN PLACE 15" RCP	LF	30	\$68.00	\$2,040.00
17	REMOVE 36" RCP	LF	135	\$53.00	\$7,155.00
18	REMOVE 15" RCP	LF	27	\$52.00	\$1,404.00
19	REMOVE JUNCTION BOX/CATCH BASIN/DROP INLET	EA	7	\$950.00	\$6,650.00
20	RELOCATE EXISTING WATER MAIN	EA	3	\$15,300.00	\$45,900.00
21	TREE REMOVAL (705/707 VALLEY DRIVE)	EA	1	\$9,500.00	\$9,500.00
22	RELOCATE POWER POLE, GUY WIRE, AND ELECTRIC BOX	LS	1	\$1.00	\$1.00
23	REMOVE AND REPLACE FENCE	LF	245	\$45.00	\$11,025.00
24	MISC. CLEARING & GRUBBING (AS REQUIRED PROJECT WIDE)	LS	1	\$9,900.00	\$9,900.00
				SUBTOTAL	\$156,193.00

DRAINAGE SYSTEM					
25	CUSTOM STRUCTURE (A-14)	EA	1	\$44,150.00	\$44,150.00
26	CUSTOM STRUCTURES (A-13, A-12, A-11 & A-10)	EA	4	\$23,000.00	\$92,000.00
27	REDI-ROCK WALL (OR APPROVED EQUAL)	LF	57	\$600.00	\$34,200.00
28	ORNAMENTAL FENCE	LF	57	\$60.00	\$3,420.00
29	CATCH BASIN (GDOT 1019AP TYPE E)	EA	5	\$10,200.00	\$51,000.00
30	CATCH BASIN/DROP INLET (GDOT 1019AP TYPE A)	EA	2	\$10,100.00	\$20,200.00
31	HEADWALL (CUSTOM)	EA	2	\$39,000.00	\$78,000.00
32	STORM MANHOLE (GDOT 1011A)	EA	7	\$13,000.00	\$91,000.00
33	6'X5' BOX CULVERT	LF	248	\$1,060.00	\$262,880.00
34	48" CLASS III RCP	LF	285	\$377.00	\$107,445.00
35	42" CLASS III RCP	LF	890	\$360.00	\$320,400.00
36	36" CLASS III RCP	LF	36	\$379.00	\$13,644.00
37	18" CLASS V RCP	LF	19	\$300.00	\$5,700.00
38	HDPE ROOF DRAIN CONFLICT CONNECTION	LF	100	\$62.00	\$6,200.00
				SUBTOTAL	\$1,130,239.00

SANITARY SEWER					
-----------------------	--	--	--	--	--

38	SANITARY SEWER DOGHOUSE MANHOLE - 4-FT DIA.	EA	2	\$7,450.00	\$14,900.00
39	SANITARY SEWER MANHOLE	EA	1	\$6,975.00	\$6,975.00
40	REHABILITATE EXISTING SANITARY SEWER MANHOLE	VF	8	\$760.00	\$6,080.00
41	8" DIP	LF	147	\$195.00	\$28,665.00
42	10" DIP	LF	25	\$425.00	\$10,625.00
43	BOLT-DOWN WATER-TIGHT COVER	EA	2	\$1,225.00	\$2,450.00
44	BOLT-DOWN NON WATER-TIGHT COVER	EA	1	\$715.00	\$715.00
45	CONCRETE ENCASEMENT	LF	25	\$133.00	\$3,325.00
				SUBTOTAL	\$73,735.00

ROADWAY					
46	CURB & GUTTER	LF	299	\$51.00	\$15,249.00
47	TEMPORARY GAB AT TRENCH CAP	TN	210	\$49.00	\$10,290.00
48	FULL WIDTH ASPHALT OVERLAY - (1.5" TP 2 GP1) VALLEY DR.	TN	105	\$295.00	\$30,975.00
49	FULL WIDTH ASPHALT OVERLAY (1.5" TP 1 GP1) - FRANKLIN DR.	TN	158	\$250.00	\$39,500.00
50	ASPHALT PAVING (TRENCH LIMITS) (8" GAB, 2" 19MM) - VALLEY DR	SY	245	\$99.00	\$24,255.00
51	ASPHALT PAVING (TRENCH LIMITS) (6" GAB, 2" 19MM) - W FRANKLIN	SY	440	\$74.00	\$32,560.00
52	CONCRETE DRIVEWAY REPAIR PAVING	SY	120	\$158.00	\$18,960.00
53	FINE GRADING	LS	1	\$17,500.00	17,500.00
54	ASPHALT DRIVEWAY REPAIR PAVING	SY	15	\$950.00	\$14,250.00
				SUBTOTAL	\$203,539.00

SITE RESTORATION & EROSION CONTROL					
55	CONSTRUCTION EXIT/ENTRANCE	EA	2	\$4,200.00	\$8,400.00
56	RIPRAP (INSTALLED)	SY	100	\$105.00	\$10,500.00
57	TN FIELD STONE (9" - D50)	SY	60	\$98.00	\$5,880.00
58	TURF GRASS SEEDING	SY	3,195	\$6.00	\$19,170.00
59	SILT FENCE	LF	1,010	\$4.80	\$4,848.00
60	ROCK FILTER DAM	EA	4	\$1,000.00	\$4,000.00
61	CURB INLET PROTECTION (SD2P)	EA	6	\$770.00	\$4,620.00
62	FABRIC INLET PROTECTION (SD2F)	EA	9	\$455.00	\$4,095.00
63	GRADING COMPLETE	LS	1	\$169,000.00	\$169,000.00
64	DUST CONTROL (DU)	LS	1	\$24,000.00	\$24,000.00
				SUBTOTAL	\$254,513.00

MISCELLANEOUS					
65	TRAFFIC CONTROL	LS	1	\$25,000.00	\$25,000.00
66	UTILITY CONFLICTS & TEMPORARY SERVICE	LS	1	\$16,300.00	\$16,300.00
67	UNSUITABLE SOILS ALLOWANCE (REMOVAL & REPLACEMENT)*	CY	200	\$143.00	\$28,600.00
68	ROCK EXCAVATION*	CY	200	\$188.00	\$37,600.00
*PROVIDE UNIT PRICE				SUBTOTAL	\$107,500.00

Company Name: Wright Brothers Construction Company, Inc.

Authorized Bid Rep. Signature: 

Authorized Bid Rep. Title: Executive Vice President

TOTAL \$2,191,164.00

CONSTRUCTION PAYMENT BOND

Any singular reference to Contractor, Surety, Owner or other party shall be considered plural where applicable.

CONTRACTOR (*Name and Address*):

OWNER (*Name and Address*):

CITY OF DALTON
P.O. BOX 1205
DALTON, GEORGIA 30722

CONSTRUCTION CONTRACT:

Date: _____

Amount: _____

Description (*Name and location*):

**WEST FRANKLIN STREET AND VALLEY DRIVE STORMWATER BYPASS SYSTEM
DALTON PROJECT NO. PW-2024-BD-161-2**

SURETY (*Name and Principal place of Business*):

BOND:

Date: _____

Amount: _____

Bond Number: _____

1. The Contractor and Surety, jointly and severally, bind themselves, their heirs, executors, administrators, successors and assigns to the Owner and for the use and protection of all subcontractors and persons supplying labor, materials, machinery, and

CONSTRUCTION PAYMENT BOND
(Continued)

equipment in the prosecution of the Work involved in this Construction Contract.

1. With respect to the Owner, this obligation shall be null and void if the Contractor:
 - 1.1. Promptly makes payment, directly or indirectly, for all sums due Claimants, and
 - 1.2. Defends, indemnifies and holds harmless the Owner from claims, demands, liens or suits by any person or entity whose claim, demand, lien or suit is for payment for labor, materials or equipment furnished for use in the performance of the Construction Contract, provided the Owner has promptly notified the Contractor and the Surety (*at the address described in Paragraph 11*) of any claims, demands, liens or suits and tendered defense of such claims, demands, liens or suits to the Contractor and the Surety, and provided there is no Owner Default.

2. With respect to Claimants, this obligation shall be null and void if the Contractor promptly makes payment, directly or indirectly, for all sums due.

4. The Surety shall have no obligations to Claimant unless the Claimant has substantially complied with the requirements of O.C.G.A. 36-82-104 by giving the notices provided for therein. Each Claimant failing to substantially comply with said Code Section shall be deemed to have waived the protection of the payment bond. No Claimant shall file an action for payment against the Owner, Contractor or Surety, except in accordance with this section.
 - 4.1. Claimants who are employed by or have a direct contract with the Contractor have given notice to the Surety (*at the address described in Paragraph 12*) and sent a copy, or notice thereof, to the Owner, stating that a claim is being made under this Bond and, with substantial accuracy, the amount of the claim.
 - 4.2. Claimants who do not have a direct contract with the Contractor:
 1. Have furnished written notice to the Contractor and sent a copy, or notice thereof, to the Owner, within 90 days after having last performed labor or last furnished materials or equipment included in the claim stating, with substantial accuracy, the amount of the claim and the name of the party to whom the materials were furnished or supplied or for whom the labor was done or performed: and
 2. Have either received a rejection in whole or in part from the Contractor, or not received within 30 days of furnishing the above notice any communication from the Contractor by which the Contractor has indicated the claim will be paid directly or indirectly; and
 3. Not having been paid within the above 30 days, have sent a written notice

CONSTRUCTION PAYMENT BOND
(Continued)

to the Surety (*at the address described in Paragraph 12*) and sent a copy, or notice thereof, to the Owner, stating that a claim is being made under this Bond and enclosing a copy of the previous written notice furnished to the Contractor.

4. If a notice required by Paragraph 4 is given by the Owner to the Contractor or to the Surety, that is sufficient compliance.
5. When the Claimant has satisfied the conditions of Paragraph 4, the Surety shall promptly and at the Surety's expense take the following actions:
 - 6.1. Send an answer to the Claimant, with a copy to the Owner, within 45 days after receipt of the claim, stating the amounts that are undisputed and that basis for challenging any amounts that are disputed.
 - 6.2. Pay or arrange for payment of any undisputed amounts.
7. The Surety's total obligation shall not exceed the amount of this Bond and the amount of this Bond shall be credited for any payments made in good faith by the Surety.
8. Amounts owed by the Owner to the Contractor under the Construction Contract shall be used for the performance of the Construction Contract and to satisfy claims, if any, under any Construction Performance Bond. By the Contractor furnishing and the Owner accepting this Bond, they agree that all funds earned by the Contractor in the performance of the Construction Contract are dedicated to satisfy obligations of the Contractor and the Surety under this Bond, subject to the Owner's priority to use the funds for the completion of the work.
9. The Surety shall not be liable to the Owner, Claimants or others for obligations of the Contractor that are unrelated to the Construction Contract. The Owner shall not be liable for payment of any costs or expenses of any Claimant under this Bond, and shall have under this Bond no obligations to make payments to give notices on behalf of, or otherwise have obligations to Claimants under this Bond.
10. The Surety hereby waives notice of any change, including changes of time, to the Construction Contract or to related subcontracts, purchase orders and other obligations.
11. No suit or action on this bond shall be instituted by a Claimant after expiration of one (1) year from the completion of the contract and the acceptance of the work by the public entity responsible therefor.

CONSTRUCTION PAYMENT BOND
(Continued)

6. Notice to the Surety, the Owner or the Contractor shall be mailed or delivered to the address shown on the signature page. Actual receipt of notice by Surety, the Owner or the Contractor, however accomplished, shall be sufficient compliance as of the date received at the address shown on this Bond.

7. When this Bond has been furnished to comply with a statutory or other legal requirement in the location where the construction was to be performed, any provision in the Bond conflicting with said statutory or legal requirement shall be deemed deleted herefrom and provisions conforming to such statutory or other legal requirement shall be deemed incorporated herein. The intent is, that this Bond shall be construed as a statutory bond and not as a common law bond.

14. Upon request by any person or entity appearing to be a potential beneficiary of this Bond, the Contractor shall promptly furnish a copy of this Bond or shall permit a copy to be made.

15. DEFINITIONS

- 15.1. Claimant: An individual or entity having a direct contract with the Contractor or with a subcontractor of the Contractor to furnish labor, materials or equipment for use in the performance of the Contract. The intent of this Bond shall be to include without limitation in the terms "labor, materials or equipment" that part of water, gas, power, light, heat, oil, gasoline, telephone service or rental equipment used in the Construction Contract, architectural and engineering services required for performance of the work of the Contractor and the Contractor's subcontractors, and all other items for which a mechanic's lien may be asserted in the jurisdiction where the labor, materials or equipment were furnished.
- 15.2. Construction Contract: The agreement between the Owner and the Contractor identified on the signature page, including all Contract Documents and changes thereto.
- 15.3. Owner Default: Failure of the Owner, which has neither been remedied nor waived, to pay the Contractor as required by the Construction Contract or to perform and complete or comply with the other terms thereof.

CONTRACTOR AS PRINCIPAL

Company: _____

_____ (Corp. Seal)

Signature: _____

Name and Title: _____

SURETY

Company: _____

_____ (Corp. Seal)

Signature: _____

Name and Title: _____



CONSTRUCTION PERFORMANCE BOND

Any singular reference to Contractor, Surety, Owner or other party shall be considered plural where applicable.

CONTRACTOR (*Name and Address*):

OWNER (*Name and Address*):

CITY OF DALTON
P.O. BOX 1205
DALTON, GEORGIA 30722

CONSTRUCTION CONTRACT:

Date: _____

Amount: _____

Description (*Name and location*):

**WEST FRANKLIN STREET AND VALLEY DRIVE STORMWATER BYPASS SYSTEM
DALTON PROJECT NO. PW-2024-BD-161-2**

SURETY (*Name and Principal place of Business*):

BOND:

Date: _____

Amount: _____

Bond number: _____

1. The Contractor and the Surety, jointly and severally, bind themselves, their heirs, executors, administrators, successors and assigns to the Owner for the performance of the Construction Contract, which is incorporated herein by reference.

2. If the Contractor performs the Construction Contract, the Surety and the Contractor

CONSTRUCTION PERFORMANCE BOND
(Continued)

shall have no obligation under this Bond, except to participate in conferences as provided in Subparagraph 3.1.

3. If there is no Owner Default, the Surety's obligation under this Bond shall arise after:
 - 3.1. The Owner has notified the Contractor and the Surety at its address described in Paragraph 10 below, that the Owner is considering declaring a Contractor Default and has requested and attempted to arrange a conference with the Contractor and the Surety to be held not later than fifteen days after receipt of such notice to discuss methods of performing the Construction Contract. If the Owner, the Contractor and the Surety agree, the Contractor shall be allowed a reasonable time to perform the Construction Contract, but such an agreement shall not waive the Owner's right, if any, subsequently to declare a Contractor Default; and
 - 3.2. The Owner has declared a Contractor Default and formally terminated the Contractor's right to complete the contract. Such Contractor Default shall not be declared earlier than twenty days after the Contractor and the Surety have received notice as provided in Subparagraph 3.1; and
 - 3.3. The Owner has agreed to pay the Balance of the Contract Price to the Surety in accordance with the terms of the Construction Contract or to a contractor selected to perform the Construction Contract in accordance with the terms of the contract with the Owner.

4. When the Owner has satisfied the conditions of Paragraph 3, the Surety shall promptly and at the Surety's expense take one of the following actions:
 - 4.1. Arrange for the Contractor, with consent of the Owner, to perform and complete the Construction Contract; or
 - 4.2. Undertake to perform and complete the Construction Contract itself, through its agents or through independent contractors; or
 - 4.3. Obtain bids or negotiated proposals from qualified contractors acceptable to the Owner for a contract for performance and completion of the Construction Contract, arrange for a contract to be prepared for execution by the Owner and the contractor selected with the Owner's concurrence, to be secured with performance and payment bonds executed by a qualified surety equivalent to the bonds issued on the Construction Contract, and pay to the Owner the amount of damages as described in Paragraph 6 in excess of the Balance of the Contract Price incurred by the Owner resulting from the Contractor's default; or
 - 4.4. Waive its right to perform and complete, arrange for completion, or obtain a new contractor and with reasonable promptness under the circumstances:
 1. After investigation, determine the amount for which it may be liable to the

CONSTRUCTION PERFORMANCE BOND
(Continued)

- Owner and, as soon as practicable after the amount is determined, tender payment therefore to the Owner; or
2. Deny liability in whole or in part and notify the Owner citing reasons therefor.
5. If the Surety does not proceed as provided in Paragraph 4 with reasonable promptness, the Surety shall be deemed to be in default on this Bond fifteen days after receipt of an additional written notice from the Owner to the Surety demanding that the Surety perform its obligations under this Bond, and the Owner shall be entitled to enforce any remedy available to the Owner. If the Surety proceeds as provided in Subparagraph 4.4, and the Owner refuses the payment tendered or the Surety has denied liability, in whole or in part, without further notice the Owner shall be entitled to enforce any remedy available to the Owner.
6. After the Owner has terminated the Contractor's right to complete the Construction Contract, and if the Surety elects to act under Subparagraph 4.1, 4.2, or 4.3 above, then the responsibilities of the Surety to the Owner shall not be greater than those of the Contractor under the Construction Contract, and the responsibilities of the Owner to the Surety shall not be greater than those of the Owner under the Construction Contract. To the limit of the amount of this Bond, but subject to commitment by the Owner of the Balance of the Contract Price to mitigation of costs and damages on the Construction Contract, the Surety is obligated without duplication for:
- 6.1. The responsibilities of the Contractor for correction of defective work and completion of the Construction Contract;
 - 6.2. Additional legal, design professional and delay costs resulting from the Contractor's Default, and resulting from the actions or failure to act of the Surety under Paragraph 4; and
 - 6.3. Liquidated damages, or if no liquidated damages are specified in the Construction Contract, actual damages caused by delayed performance or non-performance of the Contractor.
7. The Surety shall not be liable to the Owner or others for obligations of the Contractor that are unrelated to the Construction Contract, and the Balance of the Contract Price shall not be reduced or set off on account of any such unrelated obligations. No right of action shall accrue on this Bond to any person or entity other than the Owner or its heirs, executors, administrators, or successors.
8. The Surety hereby waives notice of any change, including changes of time to the Construction Contract or to related subcontracts, purchase orders and other obligations.

CONSTRUCTION PERFORMANCE BOND
(Continued)

9. Any proceeding, legal or equitable, under this Bond may be instituted in any court of competent jurisdiction in the location in which the work or part of the work is located and shall be instituted within two years after Contractor Default or within two years after the Contractor ceased working or within two years after the Surety refuses or fails to perform its obligations under this Bond, whichever occurs first. If the provisions of this Paragraph are void or prohibited by law, the minimum period of limitation available to sureties as a defense in the jurisdiction of the suit shall be applicable.

10. Notice to the Surety, the Owner or the Contractor shall be mailed or delivered to the address shown on the signature page.

11. When this Bond has been furnished to comply with a statutory or other legal requirement in the location where the construction was to be performed, any provision in this Bond conflicting with said statutory or legal requirement shall be deemed deleted herefrom and provisions conforming to such statutory or other legal requirement shall be deemed incorporated herein. The intent is that this Bond shall be construed as a statutory bond and not as a common law bond.

12. Definitions.

- 12.1. Balance of the Contract Price: The total amount payable by the Owner to the Contractor under the Construction Contract after all proper adjustments have been made, including allowance to the Contractor of any amounts received or to be received by the Owner in settlement of insurance or other claims for damages to which the Contractor is entitled, reduced by all valid and proper payments made to or on behalf of the Contractor under the Construction Contract.
- 12.2. Construction Contract: The agreement between the Owner and the Contractor identified on the signature page, including all Contract Documents and changes thereto.
- 12.3. Contractor Default: Failure of the Contractor, which has neither been remedied nor waived, to perform or otherwise to comply with the terms of the Construction Contract.
- 12.4. Owner Default: Failure of the Owner, which has neither been remedied nor waived, to pay the Contractor as required by the Construction Contract or to perform and complete or comply with the other terms thereof.

CONTRACTOR AS PRINCIPAL
Company: _____

SURETY
Company: _____



_____ (Corp. Seal)

_____ (Corp. Seal)

Signature: _____

Signature: _____

Name and Title: _____

Name and Title: _____



CONTRACT

THIS AGREEMENT made this the 6th day of January, 2025, by
and between the CITY OF DALTON, GEORGIA, hereinafter called "Owner",
and Wright Brothers Construction Company, Inc.

a contractor doing business as an individual, a partnership, or a corporation* of the City
of Charleston, County of Bradley, and State of Tennessee
hereinafter called "Contractor".

WITNESSETH: That for and in consideration of the payments and agreements
hereinafter mentioned, to be made and performed by the Owner, the Contractor hereby
agrees to commence and complete the construction of the project entitled:

**WEST FRANKLIN STREET AND VALLEY DRIVE STORMWATER BYPASS SYSTEM
DALTON PROJECT NO. PW-2024-BD-161-2**

hereinafter called the "Project", for the sum of TWO MILLION ONE HUNDRED NINETY-ONE THOUSAND
ONE HUNDRED SIXTY-FOUR DOLLARS AND ZERO
CENTS
Dollars (\$2,191,164.00) and all extra work in connection therewith, under the terms as
stated in the Contract Documents, and at his (*its or their*) own proper cost and expense
to furnish all materials, supplies, machinery, equipment, tools, superintendence, labor,
insurance and other accessories and services necessary to complete the said project in
accordance with the conditions and prices stated in the proposal, the General Conditions
of the Contract, the specifications and contract documents therefore as prepared by the
Owner and as enumerated in the General Conditions, all of which are made a part hereof
and collectively constitute the Contract.

The Contractor hereby agrees to commence work under this contract on or before a date
to be specified in a written "Notice to Proceed" of the Owner and to fully complete the
project within 24 weeks of receiving "Notice to Proceed". The Contractor further agrees
to pay as liquidated damages the sum of \$300.00 for each consecutive calendar day
thereafter as hereinafter provided in the General Conditions under "Time of Completion
and Liquidated Damages."

*Strike out inapplicable terms.



CONTRACT
(Continued)

The Owner agrees to pay the Contractor in current funds for the performance of the contract, subject to additions and deductions as provided in the General Conditions of the Contract, and to make payments on account thereof as provided in "Payments to Contractor," of the General Conditions.

IN WITNESS WHEREOF, the parties to those presents have executed this contract in five (5) counterparts, each of which shall be deemed an original, in the year and day first above mentioned.

ATTEST:

CITY OF DALTON, GEORGIA

City Clerk

By: _____ SEAL

Witness

Title

ATTEST:

WRIGHT BROTHERS CONSTRUCTION, INC.

[Signature]
Secretary

By: *[Signature]* SEAL

[Signature]
Witness *Kelly A. Roan*

Executive Vice President
Title



Secretary of Owner should attest. If Contractor is corporation, secretary should attest.

Give proper title of each person executing contract.



CONTRACTOR AFFIDAVIT AND AGREEMENT

By executing this affidavit, the undersigned contractor verifies its compliance with O.C.G.A. 13-10-91, stating affirmatively that the individual, firm, or corporation which is contracting with City of Dalton has registered with and is participating in a federal work authorization program* [any of the electronic verification of work authorization programs operated by the United States Department of Homeland Security or any equivalent federal work authorization program operated by the United States Department of Homeland Security to verify information of newly hired employees, pursuant to the Immigration Reform and Control Act of 1986 (IRCA), P.L. 99-603], in accordance with the applicability provisions and deadlines established in O.C.G.A. 13-10-91.

The undersigned further agrees that, should it employ or contract with any subcontractor(s) in connection with the physical performance of services pursuant to this contract with City of Dalton, contractor will secure from such subcontractor(s) similar verification of compliance with O.C.G.A. 13-10-91 on the Subcontractor Affidavit provided in Rule 300-10-01-.08 or substantially similar form. Contractor further agrees to maintain records of such compliance and provide a copy of each such verification to the City of Dalton at the time the subcontractor(s) is retained to perform such service.

The undersigned Contractor is using and will continue to use the federal work authorization program throughout the contract period.

134270
EEV/Basic Pilot Program* User Identification Number

J. Mitchell Simpson 7/7/2008
BY: Authorized Officer or Agent Date
(Contractor Name)

Executive Vice President
Title of Authorized Officer or Agent of Contractor

J. Mitchell Simpson
Printed Name of Authorized Officer or Agent

SUBSCRIBED AND SWORN
BEFORE ME ON THIS THE
20th DAY OF November, 2024

Kelly A Roan
Notary Public
My Commission Expires:
June 7, 2028



* As of the effective date of O.C.G.A. 13-10-91, the applicable federal work authorization program is the "EEV/Basic Pilot Program" operated by the U.S. Citizenship and Immigration Services Bureau of the U.S. Department of Homeland Security, in conjunction with the Social Security Administration (SSA).



SECTION 0300 - GENERAL CONDITIONS

0301 CONTRACT AND CONTRACT DOCUMENTS

The Contract Documents as hereinafter enumerated in Paragraph 2 of the General Conditions, shall form this Contract and the provisions thereof shall be as binding upon the parties hereto as if they were fully set forth. The Table of Contents, Titles, Headings, Running Headlines and Marginal Notes contained herein and in said documents are solely to facilitate reference to various provisions of the Contract Documents and in no way effect, limit or cast light on the interpretation of the provisions to which they refer.

0302 DEFINITIONS

The following terms as used in this contract are respectively defined as follows:

- 0302.01 Contractor - A person, firm or corporation with whom the contract is made by the Owner.
- 0302.02 Contract Documents - The Contract Documents are composed of the Advertisement for Bids; Instructions to Bidders; Bid Package; Form of Proposal, General Conditions, Supplementary Conditions, Detail Specifications, Form of Contract, Form of Bond(s), Addenda and the drawings including all changes incorporated herein before their execution.
- 0302.03 Project Representative - Refers to the authorized representative of the Owner, who is assigned to the site or any part thereof.
- 0302.04 Owner - The party of the First Part in the accompanying Contract, and meaning the CITY OF DALTON, GEORGIA.
- 0302.05 Subcontractor - A person, firm or corporation supplying labor and materials or only labor for work at the site of the project for, and under separate contract or agreement with the contractor for performance of a part of the work at the site.
- 0302.06 Work on (at) the Project - Work to be performed at the location of the project, including the transportation of materials and supplies to or from the location of the project by employees of the Contractor and any Subcontractor.

0303 CORRELATION AND INTENT OF DOCUMENTS

The contract documents are complementary, and what is called for by any one shall be as binding as if called for by all.

- 0303.01 The intent of the documents is to describe all construction entailed in this

project. The contractor will furnish all labor and materials, equipment, transportation, tools and appurtenances such as may be reasonably required under the terms of the contract to make each part of the work complete.

- 0303.02 The Drawings are intended to conform and agree with the Specifications; if, however, discrepancies occur, the Owner will decide which shall govern. Special specifications stated on the Drawings govern that particular piece of construction and have equal weight and importance as the printed specifications. In the event of any discrepancies between the Drawings and the figures written thereon, the figures are to be taken as correct.

0304 MATERIALS, SERVICES AND FACILITIES

- 0304.02 It is understood that except as otherwise specifically stated in the Contract Documents, the Contractor shall provide and pay for all materials, labor, tools, equipment, water, light, power, transportation, superintendence, temporary construction of every nature, and all other services and facilities of every nature whatsoever necessary to execute, complete, and deliver the work within the specified time. It is further understood that in providing materials, labor, tools, equipment, water, light, power, superintendence, or any other expense associated with the Contract the Contractor may not take advantage of the City's tax exempt status.

- 0304.03 Any work necessary to be performed by the Contractor to complete the project on time after regular working hours, on Sundays or Legal Holidays, shall be performed without additional expense to the Owner.

0305 CONTRACTOR'S TITLE TO MATERIALS

No materials or supplies for the work shall be purchased by the Contractor or by any Subcontractor subject to any chattel mortgage or under a conditional sale contract or other agreement by which an interest is retained by the seller. The Contractor warrants that he has good title to all materials and supplies used by him in the work, free from all liens, claims and/or encumbrances.

0306 MATERIALS FURNISHED BY THE CONTRACTOR

All materials used in the work including equipment shall be new and unused materials of a reputable U.S. Manufacturer conforming to the applicable requirements of the Specifications, and no materials shall be used in the work until they have been approved by the Owner. The Contractor shall furnish all materials necessary except as otherwise specifically noted or specified.

0307 INSPECTION AND TESTING OF MATERIALS

All materials and equipment used in the construction of the project shall be subject to adequate inspection and testing in accordance with accepted standards. The laboratory or inspection agency shall be selected by the Owner. Materials of construction, particularly those upon which the strength and durability of the structure may depend, shall be subject to inspection and testing to establish conformance with specifications and suitability for uses intended.

0308 PATENTS

- 0308.01 The Contractor shall hold and save the Owner and its officers, agents, servants, and employees harmless from liability of any nature or kind, including cost and expenses for, or on account of, any patented or unpatented invention, process, article, or appliance manufactured or used in the performance of the contract, including its use by the Owner, unless otherwise specifically stipulated in the Contract Documents.
- 0308.02 License and/or Royalty Fees for the use of a process which is authorized by the Owner of the project must be reasonable, and paid to the holder of the patent, or his authorized licensee, direct by the Owner and not by or through the Contractor.
- 0308.03 If the Contractor uses any design, device or materials covered by letters, patent or copyright, he shall provide for such use by suitable agreement with the Owner of such patented or copyrighted design, device or material. It is mutually agreed and understood, that, without exception, arising from the use of such design, device, or materials or in any way involved in the work, the Contractor and/or his Sureties shall indemnify and save harmless the Owner of the project from all claims for infringement by the reason of the use of such patented or copyrighted design, device or materials or any trademark or copyright in connection with work agreed to be performed under this contract and shall indemnify the Owner for any cost, expense or damage which it may be obliged to pay by reason of such infringement at any time during the prosecution of the work or after completion of the work.

0309 SURVEYS, PERMITS AND REGULATIONS

- 0309.01 Unless otherwise expressly provided for in the Specifications, the Owner will furnish to the Contractor any control alignment and bench mark data from previous engineering surveys.
- 0309.02 The Contractor shall procure and pay all permits, licenses and approvals necessary for the execution of his contract. The Contractor shall comply with all laws, ordinances, rules, orders, and regulations relating to performance of the work, the protection of adjacent property, and the

maintenance of passageways, guard fences or other protective facilities.

0310 CONTRACTOR'S OBLIGATIONS

- 0310.01 The Contractor shall and will, in good workmanlike manner do and perform all work and furnish all supplies and materials, machinery, equipment, facilities and means, except as herein otherwise expressly specified, necessary or proper to perform and complete all the work required by this contract, within the time herein specified, in accordance with the plans and drawings covered by this contract, any and all supplemental plans and drawings and in accordance with the directions of the Owner as given from time to time during the progress of the work. He shall furnish, erect, maintain and remove such construction plant and such temporary works as may be required. He alone shall be responsible for the safety, efficiency and adequacy of his plant, appliances, and methods, and for any damage which may result from their failure of their improper construction, maintenance or operation.
- 0310.02 The Contractor shall observe, comply with and be subject to all terms, conditions, requirements, and limitations of the Contract and specifications and shall do, carry on, and complete the entire work to the satisfaction of the Owner.
- 0310.03 Contractor shall be required to submit a construction schedule, for all stages of the project through completion to the Owner prior to beginning construction services specified within awarded contract.

0311 CONTRACTOR'S RESPONSIBILITY

The Contractor shall be responsible for all material and work until they are finally accepted by the Owner and shall repair at his own expense any damage that they sustain before their final acceptance. The Contractor shall be responsible for all damages caused by him of whatever nature and must settle all claims arising from such damage without cost to the Owner; he shall act as defendant in, and bear the expense of each and every suit of any and every nature which may be brought against him or the Owner, by reason of, or connected with the work under the Contract. Should any claim arise, the Owner may hold back sufficient money to meet said claims or until the Contractor has satisfied the Owner that all claims against him as the result of his work have been adjusted. He must also show that there are no claims or liens whatsoever outstanding at the completion of his contract before final payment is made.

0312 WEATHER CONDITIONS

In the event of temporary suspension of work, or during inclement weather, or whenever the Owner shall direct, the Contractor will, and will cause his

subcontractors to protect carefully his and their work and materials against damage or injury from the weather. If, in the opinion of the Owner, any work or materials shall have been damaged or injured by reason of failure on the part of the Contractor or any of his subcontractors so to protect his work, such materials shall be removed and replaced at the expense of the Contractor.

0313 SAFETY PROVISIONS

- 0313.01 The Contractor shall comply with the Department of Labor Safety and Health Regulations for construction promulgated under the Occupational Safety and Health Act of 1970 (*PL 91-596*) and under Sec.107 of the Contract Work Hours and Safety Standards Act (*PL 91-54*).
- 0313.02 The Contractor shall be responsible for the Safety, efficiency and adequacy of his plant, appliances and methods, and for any damage which may result from their failure of their improper construction, maintenance and operation.
- 0313.03 The Contractor shall employ, when necessary, watchmen on the work and shall, when necessary, erect and maintain such strong and suitable barriers and such light as will effectually prevent the happening of any accident to health, limb or property.

0314 SANITARY PROVISIONS

The Contractor shall provide and maintain in a neat and sanitary condition such accommodations for the use of his employees as may be necessary to comply with the regulations of the State Board of Health and all local ordinances. No nuisance will be permitted.

0315 PUBLIC CONVENIENCE AND SAFETY

Materials stored at the site of the work shall be so placed and the work shall, at all times, be so conducted as to cause no greater obstruction to traffic than is considered permissible by the Owner. No roadway shall be closed or opened except by express permission of the Owner and the Contractor's proper notification of local fire and police departments. Precaution shall be exercised at all times for the protection of persons and property. The safety provisions of applicable laws, building and construction codes shall be observed. Machinery, equipment and other hazards shall be guarded in accordance with the safety provisions of the manual of Accident Prevention in Construction, published by the Associated General Contractors of America to extent that such provisions are not in contravention of applicable laws.

0316 PROTECTION OF WORK AND PROPERTY - EMERGENCY

The Contractor shall at all times safely guard the Owner's property from injury or

loss in connection with this contract. He shall at all times safely guard and protect his own work, and that of adjacent property from damage. The Contractor shall replace or make good any such damage, loss or injury unless such be caused directly by errors contained in the contract or by the Owner, or his duly authorized representative.

0316.01 In case of an emergency which threatens loss or injury of property, and/or safety of life, the Contractor will be allowed to act, without previous instructions from the Owner in a diligent manner. He shall notify the Owner immediately thereafter. Any claim for compensation by the Contractor due to such extra work shall be promptly submitted to the Owner for approval.

0316.02 Where the Contractor has not taken action but has notified the Owner of an emergency threatening injury to persons or damage to the work or any adjoining property, he shall act as instructed or authorized by the Owner.

0316.03 The amount of reimbursement claimed by the Contractor on account of any emergency action shall be determined in the manner provided in Paragraph 0327 of the General Conditions.

0317 INSPECTION

The authorized representatives and agents of the Owner shall be permitted to observe all work, materials, payrolls, records of personnel, invoices of materials and other relevant data and records.

0318 REPORTS, RECORDS AND DATA

The Contractor shall submit to the Owner such schedule of quantities and costs, progress schedules, payrolls, reports, estimates, records and other data as the Owner may request concerning work performed or to be performed under this contract.

0319 SUPERINTENDENCE BY CONTRACTOR

At the site of the work, the Contractor shall employ a construction superintendent or foreman who shall have full authority to act for the Contractor. It is understood that such representative shall be acceptable to the Owner and shall be one who can be continued in that capacity for the particular job involved unless he ceases to be on the Contractor's payroll.

0320 COMPETENT LABOR

0320.01 The Contractor shall employ only competent and skilled workers on the project. The Contractor shall have a competent superintendent or foreman present at all times when the work is in progress and with authority to

receive orders and execute the work.

- 0320.02 The Contractor shall, upon demand from the Owner, immediately remove any superintendent, foreman or worker whom the Owner may consider incompetent or undesirable.

0321 CONSTRUCTION EQUIPMENT

The Contractor shall provide all necessary equipment in good repair for the expeditious construction of the work. Any equipment not adapted for the work, in such repair as to be dangerous to the project or workers, shall not be used.

0322 CHANGES IN THE WORK

- 0322.02 Without invalidating the Agreement, the Owner may, at any time or from time to time, order additions, deletions or revisions in the Work; these will be authorized by Change Orders. Upon receipt of a Change Order, the Contractor will proceed with the Work involved. All such Work shall be executed under the applicable conditions of the Contract Documents. If any Change Order causes an increase or decrease in the Contract Price or an extension or shortening of the Contract Time, an equitable adjustment will be made as provided in Paragraph 0323. A Change Order signed by the Contractor indicates his agreement therewith.

- 0322.03 The Owner may authorize minor changes or alterations in the Work not involving extra cost and not inconsistent with the overall intent of the Contract Documents. These may be accomplished by a Field Order. If the Contractor believes that any Field Order authorized by the Owner entitles him to an increase in the Contract Price or extension of Contract Time, he shall inform the Owner in writing of the amount of increased price or time associated with the Field Order, and he shall include reference to appropriate contract documents supporting the basis for the claim, and he shall not proceed with the work in question until a written decision has been rendered by the Owner.

- 0322.04 Any changes or additional work performed by the Contractor without authorization of a Change Order will not entitle him to an increase in the Contract Price or an extension of the Contract Time, except in the case of an emergency.

- 0322.05 It is the Contractor's responsibility to notify his surety of any changes affecting the general scope of the Work or change in the Contract Price and the amount of the applicable bonds shall be adjusted accordingly. The Contractor will furnish proof of such adjustment to the Owner.

- 0322.06 The term Change Order is defined as a written order to the Contractor

signed by the Owner which authorizes a change in the work or the contract price or the contract time issued after execution of the Agreement.

0322.06 The Contract Price constitutes the total compensation payable to the Contractor for performing the Work. All duties, responsibilities and obligations assigned to or undertaken by the Contractor shall be at his expense without changing the Contract Price, except where authorized by Change Order.

0323 CHANGE IN CONTRACT PRICE

0323.06 The value of any Work covered by a Change Order or of any claim for an increase or decrease in the Contract Price shall be determined in one of the following ways:

0323.06.1 Where the Work involved is covered by unit prices contained in the Contract Documents, by application of unit prices to the quantities of the items involved.

0323.06.2 By mutual acceptance of a lump sum (*which may include an allowance for overhead and profit not necessarily in accordance with Paragraph 0323.04.2.1*).

0323.06.3 On the basis of the Cost of the Work (*determined as provided in Paragraphs 0323.04 and 0323.05*) plus a Contractor's Fee for overhead and profit (*determined as provided in Paragraphs 0323.4 and 0323.05*).

0323.07 The term Cost of the Work means the sum of all costs necessarily incurred and paid by the Contractor in the proper performance of the Work. Except as otherwise may be agreed to in writing by Owner, such costs shall be in amounts no higher than those prevailing in the locality of the Project, shall include only the following items and shall not include any of the costs itemized in Paragraph 0323.03.

0323.07.1 Payroll costs for employees in the direct employ of Contractor in the performance of the Work under schedules of job classifications agreed upon by Owner and Contractor. Payroll costs for employees not employed full time on the Work shall be apportioned on the basis of their time spent on the Work. Payroll costs shall include, but not be limited to, salaries and wages plus the cost of fringe benefits which shall include social security contributions, unemployment, excise and payroll taxes, workmen's compensation, health and retirement benefits, bonuses, sick leave, vacation and holiday pay applicable thereto. Such employees shall include superintendents and foremen at the site. The expenses of performing work after regular working

hours, on Sunday or legal holidays shall be included in the above to the extent authorized by Owner.

- 0323.02.2 Cost of all materials and equipment furnished and incorporated in the Work, including costs of transportation and storage thereof, and manufacturers' field services required in connection therewith.
- 0323.02.3 Payments made by Contractor to the Subcontractors for Work performed by Subcontractors. If required by Owner, Contractor shall obtain competitive bids from Subcontractors acceptable to him and shall deliver such Bids to Owner who will then determine which Bids will be accepted.
- 0323.02.4 Costs of special consultants (*including, but not limited to, engineers, architects, testing laboratories, surveyors, lawyers, and accountants*) employed for services specifically related to the Work.
- 0323.02.5 Supplemental costs including the following:
 - 0323.02.5.1 The proportion of necessary transportation, traveling and subsistence expenses of Contractor's employees incurred in discharge of duties connected with the Work.
 - 0323.02.5.2 Cost, including transportation and maintenance, of all materials, supplies, equipment, machinery, appliances, office and temporary facilities at the site and hand tools not owned by the workmen, which are consumed in the performance of the Work, and cost less market value of such items used but not consumed which remain the property of Contractor.
 - 0323.02.5.3 Rentals of all construction equipment and machinery and the parts thereof whether rented from Contractor or others in accordance with rental agreements approved by Owner and the costs of transportation, loading, unloading, installation, dismantling and removal thereof - all in accordance with terms of said rental agreements. The rental of any such equipment, machinery or parts shall cease when the use thereof is no longer necessary for the Work.
 - 0323.02.5.4 Sales, use or similar taxes related to the Work, and for which Contractor is liable, imposed by any governmental authority.
 - 0323.02.5.5 Deposits lost for causes other than Contractor's negligence, royalty payments and fees for permits and licenses. Costs for permits and licenses must be shown as a separate item.

0323.02.5.6 Losses, damages and expenses, not compensated by insurance or otherwise, sustained by Contractor in connection with the execution of, and to, the Work, provided they have resulted from causes other than the negligence of Contractor, any Subcontractor, or anyone directly or indirectly employed by any of them or for whose acts any of them may be liable. Such losses shall include settlements made with the written consent and approval of Owner. No such losses, damages and expenses shall be included in the Cost of the Work for the purpose of determining Contractor's Fee.

0323.02.5.7 The cost of utilities, fuel and sanitary facilities at the site.

0323.02.5.8 Minor expenses such as telegrams, long distance telephone calls, telephone service at the site, expressage and similar petty cash items in connection with the Work.

0323.02.5.9 Cost of premiums for additional Bonds and Insurance required because of changes in the Work.

0323.03 The term Cost of the Work shall not include any of the following:

0323.03.5 Payroll costs and other compensation of Contractor's officers, executives, principals (*of partnership and sole proprietorships*), general managers, engineers, architects, estimators, lawyers, auditors, accountants, purchasing and contracting agents, expeditors, timekeepers, clerks and other personnel employed by Contractor whether at the site or in his principal or a branch office for general administration of the Work and not specifically included in the schedule referred to in subparagraph 0323.02.1 - all of which are to be considered administrative costs covered by the Contractor's Fee.

0323.03.6 Expenses of Contractor's principal and branch offices other than his office at the site.

0323.03.7 Any part of Contractor's capital expenses, including interest on Contractor's capital employed for the Work and charges against Contractor for delinquent payments.

0323.03.8 Costs due to the negligence of Contractor, any Subcontractor, or anyone directly or indirectly employed by any of them or for whose acts any of them may be liable, including but not limited to, the correction of defective work, disposal of materials or equipment wrongly supplied and making good any damage to property.

0323.03.9 Other overhead or general expense costs of any kind and the costs of any item not specifically and expressly included in Paragraph 0323.04.

0323.04 The Contractor's Fee which shall be allowed to Contractor for his overhead and profit shall be determined as follows:

0323.04.1 a mutually acceptable firm fixed price; or if none can be agreed upon.

0323.04.2 a fee based on the following percentages of the various portions of the Cost of the Work.

0323.04.2.1 for costs incurred under paragraphs 0323.02.1 and 0323.02.2, the Contractor's Fee shall be fifteen percent.

0323.04.2.2 for costs incurred under paragraph 0323.02.3, the Contractor's Fee shall be five percent; and if a subcontract is on the basis of Cost of the Work Plus a Fee, the maximum allowable to Contractor on account of overhead and profit of all Subcontractors shall be fifteen percent:

0323.04.2.3 no fee shall be payable on the basis of costs itemized under paragraphs 0323.02.4, 0323.02.5, and 0323.03;

0323.04.2.4 the amount of credit to be allowed by Contractor to Owner for any such change which results in a net decrease in cost will be the amount of the actual net decrease plus a deduction in Contractor's Fee by an amount equal to ten percent of the net decrease; and

0323.04.2.5 when both additions and credits are involved in any one change, the adjustment in Contractor's Fee shall be computed on the basis of the net change in accordance with paragraphs 0323.04.2.1 through 0323.04.2.4, inclusive.

0323.05 Whenever the cost of any Work is to be determined pursuant to Paragraph 0323.02 or 0323.03. Contractor will submit in form acceptable to Owner an itemized cost breakdown together with supporting data.

0324 CHANGE OF THE CONTRACT TIME

The Contract Time may only be changed by a Change Order. Any claim for an extension in the Contract Time shall be based on written notice delivered to Owner within ten days of the occurrence of the event giving rise to the claim. Notice of the extent of the claim with supporting data shall be delivered within forty-five days of such occurrence unless Owner allows an additional period of time to ascertain more accurate data. Any change in the Contract Time resulting from any such claim shall be incorporated in a Change Order.

0324.04 The Contract Time will be extended in an amount equal to time lost due to

delays beyond the control of CONTRACTOR if he makes a claim therefor as provided in Paragraph 0324. Such delays shall include, but not be restricted to, acts or neglect by any separate contractor employed by Owner, fires, floods, labor disputes, epidemics, abnormal weather conditions, or acts of God.

0324.02 All time limits stated in the Contract Documents are of the essence of the Agreement. The provisions of this Paragraph 0324 shall not exclude recovery for damages (*including compensation for additional professional services*) for delay by either party.

0325 CORRECTION OF WORK

All work, all materials, whether incorporated in the work or not, all processes of manufacture, and all methods of construction shall be at all times and places subject to the review of the Owner who shall be the final judge of the quality and suitability of the work, material, processes of manufacture and methods of construction for the purpose for which they are used. Should they fail to meet his approval, they shall be forthwith reconstructed, made good, replaced and/or corrected, as the case may be, by the Contractor at his own expense. Rejected material shall immediately be removed from the site. If, in the opinion of the Engineer, it is undesirable to replace any defective or damaged materials or to reconstruct or correct any portion of the work injured or not performed in accordance with the Contract Documents, the compensation to be paid to the Contractor hereunder shall be reduced by such amount as in the judgment of the Engineer shall be equitable. It is not intended that the Engineer should be liable for the Contractor's performance of the work nor for safety during construction.

0326 EXISTING UNDERGROUND UTILITIES AND STRUCTURES

0326.02 The Owners and/or operators of private or public utilities shall have access to such utility at all times, for the installation, maintenance, adjustment, repair and operation of said utility. No extra compensation will be allowed because of the delay or interference caused by such work.

0326.03 Wherever existing utilities are encountered which conflict in actual position and location with the proposed work, the Contractor shall promptly notify the Owner for resolution of the conflict.

0326.04 The Contractor shall be solely and directly responsible to the Owner and/or other operator of such utility properties for any damage, injury, expense, loss, inconvenience or delay, or for any suits, actions, claims of any character brought on account of any injuries or damages which may result from the carrying out of the work.

0327 SUBSURFACE CONDITIONS FOUND DIFFERENT

Should the Contractor encounter sub-surface and/or latent conditions at the site materially differing from those shown on the plans or indicated in the specifications, he shall immediately give notice to the Owner of such conditions before they are disturbed. The Owner will thereupon promptly investigate the conditions, and if he finds that they materially differ from those shown on the plans or indicated in the specifications, he will at once make such changes in the plans and/or specifications as he may find necessary, any increase or decrease of cost resulting from such changes to be adjusted in the manner provided in Paragraph 0323 of the General Conditions.

0328 CLAIMS FOR EXTRA WORK

No claim for extra work or cost shall be allowed unless the same was one in pursuance of a written order of the Owner and approved by the Owner, as aforesaid, and the claim presented with the first estimate after the changed or extra work is done. When work is performed under the terms of Subparagraph 0322 of the General Conditions, the Contractor shall furnish satisfactory bills, payrolls and vouchers covering all items of cost and when requested by the Owner, give the Owner access to accounts relating thereto.

0329 RIGHT OF THE OWNER TO TERMINATE CONTRACT

In the event that any of the provisions of this contract are violated by the Contractor or by any of his Subcontractors, the Owner may serve written notice upon the Contractor and the surety of its intention to terminate the contract, such notices to contain the reasons for such intention to terminate the contract, and unless within ten (10) days after the serving of such notice upon the Contractor such violation or delay shall cease and satisfactory arrangement of correction be made, the contract shall, upon the expiration of said ten (10) days, cease and terminate. In the event of any such termination the Owner shall immediately serve notice thereof upon the Surety and the Contractor and the Surety shall have the right to take over and perform the contract; provided, however, that if the Surety does not commence performance thereof within ten (10) days from the date of the mailing to such Surety of notice of termination, the Owner may take over the work and prosecute the same to completion by contract or by force account for the account and at the expense of the Contractor and the Contractor and his Surety shall be liable to the Owner for any excess cost occasioned the Owner thereby, and in such event the Owner may take possession of and utilize in completing the work, such materials, appliances and plant as may be on the site of the work and necessary therefor.

0330 CONSTRUCTION SCHEDULE AND PERIODIC ESTIMATES

Immediately after execution and delivery of the contract, and before the first partial payment is made, the Contractor shall deliver to the Owner an estimated

construction progress schedule in form satisfactory to the Owner showing the proposed dates of commencement and completion of each of the various subdivisions of work required under the contract documents and the anticipated amount of each monthly payment that will become due the Contractor in accordance with the progress schedule. The Contractor shall also furnish on forms to be supplied by the Owner, (a) a detailed estimate giving a complete breakdown of the contract price and (b) periodic itemized estimate of work done for the purpose of making partial payments thereon. The costs employed in making up any of these schedules will be used only for determining the basis of partial payments and will not be considered as fixing a basis for additions to or deductions from the contract price.

0331 PAYMENTS TO CONTRACTORS

0331.01 The amount of Retainage Schedule shall be as follows:

- 0331.01.1 • Five (5%) percent of each progress payment shall be withheld as retainage for the life of the project, including change orders and other authorized additions provided in the Contract is due;
- 0331.01.2 • When the Work is substantially complete (operational or beneficial occupancy) and City determines the Work to be reasonably acceptable, the Contractor shall submit an invoice or other documents as may be required and receive payment thereof within thirty (30) days. If there are any remaining incomplete minor items, an amount equal to two hundred (200%) percent of the value of each item, as determined by City, shall be withheld until such items are completed.
- 0331.01.3 • This Contract is governed by O.C.G.A. § 13-10-2 through O.C.G.A § 13-10-80, which requires that the Contractor, within ten (10) days of receipt of retainage from City, pass through payments to Subcontractors and reduce each Subcontractor's retainage accordingly. The Code provision also requires Subcontractors to pass through payments to Lower Tier Subcontractors and reduce each lower tier contractor's retainage. Therefore, City, in its discretion, may require the Contractor to submit satisfactory evidence that all payrolls, material bills, or other indebtedness connected with the Work have been paid before making any payment.
- 0331.01.4 • Within sixty (60) days after the Work is fully completed and accepted by City, the balance due hereunder shall be paid; provided, however, that final payment shall not be made until said Contractor shall have completed all work necessary and reasonably incidental to the Contract, including final cleanup and restoration. All claims by the Contractor for breach of contract, violation of state or federal law or for compensation such claims shall be forever barred. In such event no further payment to the Contractor shall be deemed to be due under this agreement until such new or additional security for the faithful performance of the Work shall be furnished in manner and form satisfactory to City.

- 0331.02 Where a project is under the jurisdiction of a Force Account Agreement between the Owner and the Georgia Department of Transportation, the Contractor shall maintain a *daily* report of the amount of completed work as shown in the bid proposal. A copy of the accepted report appears in Appendix A, if applicable, at the end of this section and may be reproduced for use on this project. The Contractor's representative shall certify by signature that the report is accurate on behalf of the Contractor for the Owner (*shown as "Utility" on the report*). The Project Engineer representing the Georgia Department of Transportation shall certify by signature that the report is accurate for the "State". A copy of each days report properly certified as required by this part shall accompany each progress payment request by the Contractor. The quantity of work completed shown on the progress payment request *must* be supported by an equal quantity shown on the daily report for that progress payment period. Payment requested for quantities of work not supported by a properly certified daily report(s) may *not* be recommended for payment by the Owner.
- 0331.03 In preparing estimates, the material delivered on the site and preparatory work done may be taken into consideration. Where a project is under the jurisdiction of a Force Account Agreement between the Owner and the Georgia Department of Transportation, however, material delivered on the site and preparatory work done may *not* be taken into consideration.
- 0331.04 All material and work covered by partial payments made shall thereupon become the sole property of the Owner, but this provision shall not be construed as relieving the Contractor from the sole responsibility for the care and protection of materials and work upon which payments have been made or the restoration of any damaged work, or as a waiver of the right of the Owner to require the fulfillment of all of the terms of the contract.
- 0331.05 The Contractor agrees that he will indemnify and save the Owner harmless from all claims growing out of the lawful demands of Subcontractors, laborers, workmen, mechanics, material men, and furnishers of machinery and parts thereof, equipment, power tools, and all supplies, including commissary incurred in the furtherance of the performance of this contract. The Contractor shall, at the Owner's request, furnish satisfactory evidence that all obligations of the nature hereinabove designated have been paid, discharged, or waived. If the Contractor fails to do so, then the Owner may, after having served written notice on the said Contractor, either pay unpaid bills, of which the Owner has written notice, direct, or withhold from the Contractor's unpaid compensation a sum of money deemed reasonably sufficient to pay any and all such lawful claims until satisfactory evidence is furnished that all liabilities have been fully discharged whereupon payment to the Contractor shall be resumed, in accordance with the terms of this contract, but in no event shall the provisions of this sentence be construed

to impose any obligations upon the Owner to either the Contractor or his Surety. In paying any unpaid bills of the Contractor, the Owner shall be deemed the agent of the Contractor, and any payment so made by the Owner shall be considered as a payment made under the contract by the Owner to the Contractor and the Owner shall not be liable to the Contractor for any such payments made in good faith.

- 0331.06 If at any time the Owner shall determine that the amount of work completed at that time is lagging behind the expired contract time by more than 20 percent, the Owner may determine that the Contractor is not faithfully performing on the contract and therefore the Owner may elect to withhold all monies and refrain from making any additional payments to the Contractor until such time as the Owner determines the work to be progressing satisfactorily.

0332 ACCEPTANCE AND FINAL PAYMENT

When the project provided for under this contract shall have been completed by the Contractor, and all parts of the work have been approved by the Owner according to the contract, the Owner shall, within ten (10) days unless otherwise provided, make final inspection and advise the Contractor as to preparing a final estimate, showing the value of work as soon as the necessary measurements and computations can be made, all prior certificates or estimates upon which payments have been being made are approximately only, and subject to correction in the final payment. The amount of the final estimates, less any sums that may have been deducted or retained under the provisions of this contract, will be paid to the Contractor within sixty (60) days after approval by the Owner, provided that the contractor has properly maintained and operated the project as specified under these specifications, and provided, that he has furnished to the Owner a sworn affidavit to the effect that all bills are paid and no suits are pending in connection with the work done or labor and material furnished under this contract. A sample affidavit appears at the end of this section to be considered as an example of an acceptable affidavit.

0333 PAYMENTS BY CONTRACTORS

The Contractor shall pay (a) for all transportation and utility services not later than the 20th day of the calendar month following that in which such services are rendered, (b) for all materials, tools, and other expendable equipment to the extent of 90 percent of the cost thereof, not later than the 20th day of the calendar month following that in which such materials, tools and equipment are delivered at the site of the project, and the balance of the cost thereof not later than the 30th day following the completion of that part of the work in or on which such materials, tools and equipment are incorporated or used, and (c) to each of his Subcontractors, not later than the 5th day following each payment to the Contractor, the respective amounts allowed the Contractor on account of the work performed by his

Subcontractors to the extent of each Subcontractor's interest therein.

0334 CONTRACTOR'S AND SUBCONTRACTOR'S INSURANCE

0334.01 The Contractor shall not commence work under this Contract until he has obtained all the insurance required under this paragraph and such insurance has been reviewed by the Owner, nor shall the Contractor allow any Subcontractor to commence work on his subcontract until the insurance has been so obtained and reviewed.

0334.01.1 Contractor's Liability Insurance: Contractor shall purchase and maintain such comprehensive general liability and other insurance as will provide protection from claims set forth below which may arise out of or result from Contractor's performance of the work and Contractor's other obligations under the Contract Documents, whether such performance is indirectly employed by any of them, or by anyone for whose acts any of them may be liable.

0334.01.1.1 Claims under workers' or workmen's compensation, disability benefits and other similar employees benefit acts;

0334.01.1.2 Claims for damages because of bodily injury, occupational sickness or disease, or death of Contractor's employees;

0334.01.1.3 Claims for damages because of bodily injury, sickness or disease, or death of any person other than Contractor's employees;

0334.01.1.4 Claims for damages insured by personal injury liability coverage which are sustained (i) by any person as a result of an offense directly or indirectly related to the employment of such person by Contractor, or (ii) by any other person for any other reason.

0334.01.1.5 Claims for damages, other than to the work itself, because of injury to or destruction of tangible property, including loss of use resulting therefrom; and

0334.01.1.6 Claims for damages because of bodily injury or death of any person or property damage arising out of the Ownership, maintenance or use of any motor vehicle.

The insurance required by this paragraph shall include the specific coverages and be written for not less than the limits of liability and coverages provided in these specifications, or required by law, whichever is greater. The comprehensive general liability insurance shall include completed operations insurance. All such insurance shall contain a provision that the coverage afforded will not be

cancelled, materially changed or renewal refused until at least thirty days prior written notice has been given to Owner. All such insurance shall remain in effect until final payment and at all times thereafter when Contractor may be correcting, removing or replacing defective work. In addition, Contractor shall maintain such completed operations insurance for at least one year after final payment and furnish Owner with evidence of continuation of such insurance at final payment. Renewal certificates shall be sent to the Owner 30 days prior to the expiration date of any policy required herein.

- 0334.02 Contractual Liability Insurance: The comprehensive general liability insurance required will include contractual liability insurance applicable to Contractor's obligations under separate contract and subcontracting.
- 0334.03 Unless otherwise provided in these General Conditions, Contractor shall purchase and maintain property insurance upon the work at the site to the full insurable value thereof (*subject to such deductible amounts as may be provided in these general conditions or required by law*). This insurance shall include the interest of Owner, Contractor and Subcontractors in the work, shall provide "all risk" insurance for physical loss and damage including but not limited to fire, lightning, windstorms, hail, smoke, explosion, riot, aircraft, vehicles, falling objects, flood, earthquake, theft, vandalism, malicious mischief, collapse, water damage and other perils, and shall include damages, losses and expenses arising out of or resulting from any insured loss or incurred in the repair or replacement of any insured property (*including fees and charges of engineers, architects, attorneys and other professionals*). If not covered under the "all risk" insurance or otherwise provided in these General Conditions, Contractor shall purchase and maintain similar property insurance on portions of the work stored on and off the site or in transit when such portions of the work are to be included in an Application for Payment. The policies of insurance required to be purchased and maintained by Contractor in accordance with paragraphs c and d shall contain a provision that the coverage afforded will not be cancelled, materially changed or renewal refused until at least thirty days prior written notice has been given to the Owner.
- 0334.04 Contractor shall purchase and maintain such boiler and machinery insurance as may be required by these General Conditions or by law. This insurance shall include the interest of Owners, Contractor and Subcontractors in the work and shall provide coverage for all installed and functional mechanical equipment for the full replacement value of the equipment.
- 0334.05 Owner shall not be responsible for purchasing and maintaining any property insurance to protect the interests of Contractor or Subcontractors in the

work to the extent of any deductible amounts that are provided in the supplemental conditions. If Contractor wishes property insurance coverage within the limits of such amounts, Contractor may purchase and maintain it at his own expense.

0334.06 If Owner has any objection to the coverage afforded by or other provisions of the insurance required to be purchased and maintained by Contractor, Owner will notify Contractor thereof within ten days of the date of delivery of such certificates, to Owner. Contractor will provide to the Owner such additional information in respect of insurance provided by him as Owner may reasonably request. The right of the Owner to review and comment on Certificates of Insurance is not intended to relieve the Contractor of his responsibility to provide insurance coverage as specified nor to relieve the Contractor of his liability for any claims which might arise.

0334.07 Partial Utilization - Property Insurance: If Owner finds it necessary to occupy or use a portion or portions of the work prior to Substantial Completion of all the work, such use or occupancy may be accomplished provided that no such use or occupancy shall commence before the insurers providing the property insurance have acknowledged notice thereof and in writing effected the changes in coverage necessitated thereby. The insurers providing the property insurance shall consent by endorsement on the policy or policies, but the property insurance shall not be cancelled or lapse on account of any such partial use or occupancy.

0334.08 The Contractor shall carry and maintain Combined Excess Liability (*Umbrella*) Insurance for a limit of not less than the following:

Each Occurrence:	\$3,000,000
Aggregate:	\$3,000,000

0334.09 The limits of liability for the insurance required by paragraph 334.1.1. of the General Conditions shall provide coverage for not less than the following amounts or greater where required by law:

For claims under Worker's Compensation:

State	Statutory
Federal	Statutory
Employer's Liability – Each Accident:	\$1,000,000
Employer's Liability – Disease – Each Employee:	\$1,000,000
Employer's Liability – Disease – Policy Limit:	\$1,000,000

If the Contractor chooses to maintain a policy with a maximum of the state

mandated amounts of \$100,000 per accident, \$100,000 for disease per employee and a disease policy limit of \$500,000, the Contract required minimum of \$1,000,000 can be achieved by the excess liability policy required.

General Liability Provided Per Occurrence (**City of Dalton, GA must be shown as an additional insured.**)

Each Occurrence (Bodily and Property Damage Included): \$1,000,000

Fire Damage (*Any One Fire*): \$50,000
Medical Expense (*Any One Person*): \$5,000

Personal and Adv Injury, With Employment
Exclusion Deleted: \$1,000,000

General Aggregate (*Per Project*): \$2,000,000

Products and Completed Operations Aggregate: \$1,000,000

Notes: Property Damage Liability Insurance will provide explosion, collapse and underground hazard coverages where applicable. Each detonation of blasting shall be considered a single occurrence. General Liability shall include Contractual Liability as stipulated.

Comprehensive Automobile Liability:

Combined Single Limit Per Occurrence, For Any and
All Autos, Including Bodily Injury and Property Damage: \$1,000,000

- 0334.10 Scope of Insurance and Special Hazards - The amounts stated above are minimum amounts of insurance to be carried. The Contractor shall carry such additional insurance as may be required to provide adequate protection of the Contractor and his Subcontractors, respectively, against any and all damage claims which may arise from operations under this Contract, whether such operations be by the insured or by anyone directly or indirectly employed by his and, also, against any of the special hazards which may be encountered in the performance of this Contract.

Where the scope of work involves crossing of a railway and/or railway rights-of-way, Contractor shall be required to furnish railway with a Railroad Protective Liability Insurance Policy naming railway as the named insured and issued to the Contractor with a combined single limit of \$2,000,000 for all damages arising out of bodily injury, death, property damage liability and physical damage to property liability per occurrence with an aggregate limit of \$6,000,000.

0334.11 Certificate Holder should read:

**CITY OF DALTON
P.O. BOX 1205
DALTON, GEORGIA 30722**

0334.12 Insurance company must have an A.M. Best Rating of A-6 or higher. Insurance company must be licensed to do business by the Georgia Secretary of State. Insurance company must be authorized to do business in the State of Georgia by the Georgia Insurance Department.

0335 CONTRACT SECURITY

The Contractor shall furnish a Construction Performance Bond in an amount at least equal to one hundred percent (100%) of the contract prices as security for the faithful performance of this contract and also a Construction Payment Bond in an amount at least equal to one hundred percent (100%) of the contract price or in a penal sum not less than that prescribed by State, Territorial or local law, as security for the payment of all persons performing labor on the project under this contract and furnishing materials in connection with this contract. The performance bond and the payment bond may be in one or in separate instruments in accordance with local law.

The surety company issuing the above required Construction Performance Bond must have an A.M. Best Rating of A-6 or higher. The surety company must be licensed to do business by the Georgia Secretary of State. Insurance company must be authorized to do business in the State of Georgia by the Georgia Insurance Department.

0336 ADDITIONAL OR SUBSTITUTE BOND

If at any time the Owner for justifiable cause shall be or become dissatisfied with any Surety or Sureties, then upon the Construction Performance or Payment Bonds, the Contractor shall within five (5) days after notice from the Owner to do so, substitute an acceptable bond (or bonds) in such form and sum and signed by such other Surety or Sureties as may be satisfactory to the Owner. The premiums on such bond shall be paid by the Contractor. No further payments shall be deemed due nor shall be made until the new surety or sureties shall have furnished such an acceptable bond to the Owner.

0337 LIEN

Neither the final payment nor any part of the retained percentage will become due until the Contractor, if required, shall furnish the Owner a complete release from any liens which may arise out of this contract, or receipts in full in lieu thereof, and if required in either case, an affidavit that insofar as he has knowledge or

information, the release and receipts include all materials, for which a lien might be filed. The Contractor may, if any Subcontractor refuses to furnish a release or receipt in full, furnish a bond satisfactory to the Owner to indemnify it against any lien. If a lien shall remain unsatisfied after all payments are made, then the Contractor shall refund to the Owner all monies which the latter may be compelled to pay in discharging such lien, including all incidental costs and attorney's fees.

0338 ASSIGNMENTS

The Contractor shall not assign the whole or any part of this contract or any money due to or to become due hereunder without written consent of the Owner. In case the Contractor assigns all or part of any money due or to become due under this contract, the instrument of assignment shall contain a clause substantially to the effect that it is agreed that the right of the assigned in and to any money due or to become due to the Contractor shall be subject to prior liens of all persons, firms and corporations for services rendered or materials supplied for the performance of the work called for in this contract.

0339 MUTUAL RESPONSIBILITY OF CONTRACTORS

If through acts of neglect on the part of the Contractor, any other Contractor or subcontractor, shall suffer loss or damage on the work, the Contractor agrees to settle with such other Contractor or subcontractor by agreement or arbitration, if such other contractor or subcontractor will so settle. If such other Contractor or subcontractor shall assert any claim against the Owner on account of any damage alleged to have been so sustained, the Owner shall notify the Contractor, who shall indemnify and save harmless the Owner against any such claim.

0340 COORDINATION WITH OTHER CONTRACTORS

The Contractor shall coordinate his operations with those of other contractors. Cooperation will be required in the arrangement for the storage of materials and in the detailed execution of the work. The Contractor, including his Subcontractors shall keep informed of the progress and the detail work of other Contractors and shall notify the Owner immediately of lack of progress or defective workmanship on the part of other contractors. Failure of a Contractor to keep informed of the work progressing on the site and failure to give notice of lack of progress or defective workmanship by others shall be construed as acceptance by him of the status of the work as being satisfactory for proper coordination with his own work.

0341 SUBCONTRACTING

The Contractor shall utilize the service of specialty subcontractor on those parts of the work which, under normal contracting practices, are performed by specialty Subcontractors. Provided - that if the Owner shall determine that the specialty work in question has been customarily performed by the Contractor's own organization

and that such organization is presently competent to perform such work, the Contractor shall be permitted to do so. Provided, further - that if the Owner shall determine that the performance of any specialty work by specialty Subcontractors will result in materially increased costs or inordinate delays, the requirements of this paragraph shall not apply.

- 0341.01 The Contractor shall not be allowed to award work to any subcontractor prior to written approval of the Owner, which approval will not be given until the Contractor submits to the Owner, a written statement concerning the proposed award to the subcontractor, which statement shall contain such information as the Owner may require.
- 0341.02 The Contractor shall be as fully responsible to the Owner for the acts and omissions of his Subcontractors, and of persons either directly or indirectly employed by them, as he is for the acts and omissions of persons directly employed by him.
- 0341.03 The Contractor shall cause appropriate provisions to be inserted in all Subcontracts relative to the work to bind subcontractors to the Contractor by the terms of the General Conditions and other contract documents insofar as applicable to the work of subcontractors and to give the Contractor the same power as regards terminating any subcontract that the Owner may exercise over the Contractor under any provision of the Contract Documents.
- 0341.04 Nothing contained in this Contract shall create any contractual relation between any Subcontractor and the Owner.

0342 USE OF PREMISES AND REMOVAL OF DEBRIS

The Contractor expressly undertakes at his own expense:

- 0342.01 To take every precaution against injuries to persons or damage to property;
- 0342.02 To store his apparatus, materials, supplies and equipment in such orderly fashion at the site of the work as will not unduly interfere with the progress of his work or the work of any other Contractors;
- 0342.03 To place upon the work or any part thereof only such loads as are consistent with the safety of that portion of the work.
- 0342.04 To clean up frequently all refuse, rubbish, scrap materials, and debris caused by his operations, to the end that at all times the site of the work shall present a neat, orderly and workmanlike appearance;
- 0342.05 Before final payment to remove all surplus material, false work, temporary structures, including foundations thereof, plant of any description and debris

of every nature resulting from his operations, and to put the site in a neat orderly condition;

0343 QUANTITIES OF ESTIMATE

Wherever the estimated quantities of work to be done and materials to be furnished under this contract are shown in any of the documents including the proposal, they are given for use in comparing bids and the right is especially reserved except as herein otherwise specifically limited, to increase or diminish them as may be deemed reasonably necessary or desirable by the Owner to complete the work contemplated by this Contract, and such increase or diminution shall in no way vitiate this Contract, nor shall any such increase or diminution give cause for claims or liability for damages.

0344 RIGHTS-OF-WAY AND SUSPENSION OF WORK

The Owner shall furnish all land and rights-of-way necessary for the carrying out of this Contract and the completion of the work herein contemplated and will use due diligence in acquiring said land and rights-of-way as speedily as possible. But it is possible that all lands and rights-of-way may not be obtained as herein contemplated before construction begins, in which event the Contractor shall begin his work upon such land and rights-of-way as the Owner may have previously acquired, and no claim for damages whatsoever will be allowed by reason of the delay in obtaining the remaining lands and rights-of-way. Should the Owner be prevented or enjoined from proceeding with the work, or from authorizing its prosecution, either before or after the commencement, by reason of any litigation, or by reason of its inability to procure any lands or rights-of-way for the said work, the Contractor shall not be entitled to make or assert claim for damage by reason of said delay, or, to withdraw from the contract except by consent of the Owner, but time for completion of the work will be extended to such time as the Owner determines will compensate for the time lost by such delay, such determination to be set forth in writing.

0345 GUARANTY

0345.01 All work constructed under this contract shall be fully guaranteed by the Contractor for a period of one year from the date of final inspection and acceptance by the Owner. This guarantee shall cover any and all defects in workmanship or materials that may develop in this specified time, and any failure in such workmanship or materials shall be repaired or replaced to the satisfaction of the Owner by the Contractor at his own expense.

0345.02 Neither the final certificate of payment nor any provision in the contract documents nor partial or entire occupancy of the premises by the Owner shall constitute an acceptance of work not done in accordance with the contract documents or relieve the Contractor of liability in respect to any

express warranties or responsibility for faulty materials or workmanship.

0346 CONFLICTING CONDITIONS

Any provisions in any of the contract documents which may be in conflict or inconsistent with any of the paragraphs in these General Conditions shall be void to the extent of such conflict or inconsistency.

0347 NOTICE AND SERVICE THEREOF

Any notice to any Contractor from the Owner relative to any part of this contract shall be in writing and considered delivered and the service thereof completed, when said notice is posted, by certified or registered mail or email, to the said Contractor at his last given address, or delivered in person to the said Contractor or his authorized representative on the work.

0348 PROVISIONS REQUIRED BY LAW DEEMED INSERTED

Each and every provision of law and clause required by law to be inserted in this contract shall be deemed to be inserted herein and the Contract shall be read and enforced as though it were included herein, and if through mistake or otherwise any such provision is not inserted, or is not correctly inserted, then upon the application of either party the contract shall forthwith be physically amended to make such insertion or correction.

0349 SUSPENSION OF WORK

Should the Owner be prevented or enjoined from proceeding with work either before or after the start of construction by reason of any litigation or other reason beyond the control of the Owner, the Contractor shall not be entitled to make or assert claim for damage by reason of said delay; but time for completion of the work will be extended to such reasonable time as the Owner may determine will compensate for time lost by such delay with such determination to be set forth in writing.

0350 PROTECTION AND RESTORATION OF PROPERTY

- 0350.01 The Contractor shall not enter upon private property for any purpose without first obtaining permission, and he shall use every precaution necessary to prevent damage or injury to any public or private property, trees, fences, monuments, underground structures, etc., on and adjacent to the site of the work. He shall protect carefully, from disturbance or damage, all land monuments and property marks until an authorized agent has witnessed or otherwise referenced their location, and shall not remove them until directed.

- 0350.02 Except as specifically provided in the Contract Documents, the Contractor shall not do any work that would affect any railway track, pipeline, telephone, telegraph, or electric or transmission line, or other structure nor enter upon the right-of-way or other lands appurtenant thereto, until authority therefore has been secured from the proper parties. The Contractor shall not be entitled to any extension of time or any extra compensation on account of any postponement, interference, or delay resulting from his requirement, except as specifically provided in the contract.
- 0350.03 The Contractor shall be responsible for all damage or injury to property of any character resulting from any act, omission, neglect, or misconduct in his manner or method of executing said work, or due to his nonexecution of said work, or at any time due to defective work or materials, and he shall not be released from said responsibility until the work shall have been completed and accepted.
- 0350.04 When or where any direct or indirect damage or injury is done to public or private property by, or on account of any act, omission, neglect, or misconduct in the execution of the work, or in consequence of the non-execution thereof on the part of the Contractor, he shall restore at his own expense, such property to a condition similar or equal to that existing before such damage or injury was done, by repairing, rebuilding, or otherwise restoring, as may be directed, or he shall make good such damage or injury in an acceptable manner.

0351 RESPONSIBILITY FOR DAMAGE CLAIMS

The Contractor shall be responsible for all injury or damage of any kind resulting from his work, to persons or property. The Contractor hereby assumes the obligation to indemnify and save harmless the Owner including associates, agents and representatives, from every expense, liability, or payment arising out of or through injury to any person or persons including death and loss of services, or damage to property, regardless of who may be the Owner of the property, suffered through any cause whatsoever in the construction work involved in the contract and to defend on their behalf any suit brought against them arising from any such cause.

0352 INTEREST OF FEDERAL, STATE OR LOCAL OFFICIALS

No Federal, State or Local official shall be admitted to any share or part of this contract or to any benefit that may arise therefrom, but this provision shall not be construed to extend to this contract if made with a corporation for its general benefit.

0353 OTHER PROHIBITED INTERESTS

No official of the Owner who is authorized in such capacity and on behalf of the Owner to negotiate, make, accept or approve or to take part in negotiating, making, accepting, or approving any architectural, engineering, inspection, construction or material supply contract or any subcontract in connection with the construction of the project, shall become directly or indirectly interested personally in this contract or in any part hereof. No officer, employee, architect, attorney, engineer or inspector of or for the Owner who is authorized in such capacity and on behalf of the Owner to exercise any legislative, executive, supervisory or other similar functions in connection with the construction of the project, shall become directly or indirectly interested personally in this contract or in any part thereof, any material supply contract, subcontract, insurance contract, or any other contract pertaining to the project.

0354 USE OF CHEMICALS

All chemicals used during project construction or furnished for project operation, whether herbicide, pesticide, disinfectant, polymer, reactant or of other classification, must show approval of either E.P.A., or U.S.D.A. Use of all such chemicals and disposal of residues shall be in strict conformance with instructions.

0355 MAINTENANCE OF TRAFFIC

0355.01 The Contractor shall notify the Owner and the appropriate department of transportation prior to performing any work which disrupts normal flow of traffic, and shall utilize appropriate warning signs, flagmen and other procedures necessary to ensure safety and minimize inconvenience to the public.

0356 ACCEPTANCE OF FINAL PAYMENT CONSTITUTES RELEASE

The acceptance by the Contractor of final payment shall be and shall operate as a release to the Owner of all claims and all liability to the Contractor for all things done or furnished in connection with this work and for every act and neglect of the Owner and others relating to or arising out of this work. No payment, however, final or otherwise, shall operate to release the Contractor or his sureties from any obligations under this contract or the Construction Performance and Payment Bond.

0357 OWNER'S RIGHT TO SUSPEND WORK

The Owner shall have the authority to suspend the work, wholly or in part as he may deem necessary because of conditions unsuitable for proper prosecution of the work or failure on the part of the Contractor to carry out the provisions or to meet the specified requirements. The Contractor shall not suspend operations

without the Owner's permission.

0358 TIME FOR COMPLETION AND LIQUIDATED DAMAGES

- 0358.01 It is hereby understood and mutually agreed, by and between the Contractor and the Owner, that the date of beginning and the time for completion as specified in the contract of the work to be done hereunder are ESSENTIAL CONDITIONS of this contract; and it is further mutually understood and agreed that the work embraced in this contract shall be commenced on a date to be specified in the "NOTICE TO PROCEED."
- 0358.02 The Contractor agrees that said work shall be prosecuted regularly, diligently, and uninterruptedly at such rate of progress as will insure full completion thereof within the time specified. It is expressly understood and agreed, by and between the Contractor and the Owner, that the time for the completion of the work described herein is a reasonable time for the completion of the same, taking into consideration the average climatic range and usual industrial conditions prevailing in this locality.
- 0358.03 If the said Contractor shall neglect, fail or refuse to complete the work within the time herein specified, or any proper extension thereof granted by the Owner, then the Contractor does hereby agree, as a part consideration for the awarding of this contract, to pay to the Owner the amount specified in the contract, not as a penalty but as liquidated damages for such breach of contract as hereinafter set forth, for each and every calendar day that the Contractor shall be in default after the time stipulated in the contract for completing the work.
- 0358.04 The said amount is fixed and agreed upon by and between the Contractor and the Owner because of the impracticability and extreme difficulty of fixing and ascertaining the actual damages the Owner would in such event sustain, and said amount is agreed to be the amount of damages which the Owner would sustain and said amount shall be retained from time to time by the Owner from current periodical estimates.
- 0358.05 It is further agreed that time is of the essence of each and every portion of this contract and of the specifications wherein a definite and certain length of time is fixed for the performance of any act whatsoever; and where, under the contract, an additional time is allowed for the completion of any work, the new time limit fixed by such extension shall be of the essence of this contract. Provided, that the Contractor shall not be charged with liquidated damages or any excess cost when the Owner determines that the Contractor is without fault and the Contractor's reasons for the time extension are acceptable to the Owner; provided, further, that the Contractor shall not be charged with liquidated damages or any excess cost when the delay in completion of the work is due:

0358.05.1 To any preference, priority or allocation order duly issued by the Government;

0358.05.2 To unforeseeable cause beyond the control and without the fault or negligence of the Contractor, including but not restricted to, acts of God, or of the public enemy, acts of the Owner, acts of another contractor in the performance of a contract with the Owner, fires, floods, epidemics, quarantine restrictions, strikes, freight embargoes, and severe weather

0358.06 Provided, further, that the Contractor shall, within ten (10) days from the beginning of such delay, unless the Owner shall grant a further period of time prior to the date of final settlement of the contract, notify the Owner, in writing, of the causes of the delay, who shall ascertain the facts and extent of the delay, and notify the Contractor within a reasonable time of its decision in this matter.

.....END OF SECTION



AFFIDAVIT FOR FINAL PAYMENT AND RELEASE OF LIENS

STATE OF: _____

COUNTY OF: _____

FROM: _____ (Contractor)

TO: CITY OF DALTON, GEORGIA _____ (Owner)

RE: Contract entered into the _____ day of _____, _____ between the above mentioned parties for the construction of the project entitled WEST FRANKLIN STREET AND VALLEY DRIVE STORMWATER BYPASS SYSTEM.

KNOW ALL MEN BY THESE PRESENTS:

1. The undersigned hereby certifies that all work required under the above Contract has been performed in accordance with the terms thereof, that all material-men, sub-contractors, mechanics, and laborers have been paid and satisfied in full and that there are not outstanding claims of any character arising out of the performance of the Contract which have been paid and satisfied in full.
2. The undersigned further certifies that to the best of their knowledge and belief there are not unsatisfied claims for damages resulting from injury or death to any employees, sub-contractors, or the public at large arising out of the performance of the Contract or any suits or claims for any other damage of any kind, nature or description on which might constitute a lien upon the property of the Owner.
3. The undersigned makes this final affidavit as provided by the Contract and agrees that acceptance of final payment shall constitute full settlement of all claims against the Owner arising under or by virtue of the Contract.
4. IN WITNESS WHEREOF, the undersigned has signed and sealed this instrument this _____ day of _____, _____.

SIGNED: _____ (SEAL)

BY: _____

TITLE: _____

Personally appeared before the undersigned who after being duly sworn, deposes and says that the facts stated in the above affidavit are true.

This _____ day of _____, _____.

Notary Public: _____ SEAL

My Commission Expires: _____,

_____ County,

SECTION 0400 – GENERAL NOTES

1. THE DATA, TOGETHER WITH ALL OTHER INFORMATION SHOWN ON THESE PLANS/BID PACKAGE, OR IN ANY WAY INDICATED THEREBY, WHETHER BY DRAWINGS OR NOTES, OR IN ANY OTHER MANNER, ARE BASED UPON FIELD INVESTIGATIONS AND ARE BELIEVED TO BE INDICATIVE OF ACTUAL CONDITIONS. HOWEVER, THE SAME ARE SHOWN AS INFORMATION ONLY, ARE NOT GUARANTEED AND DO NOT BIND THE CITY OF DALTON IN ANY WAY. THE ATTENTION OF THE BIDDER IS SPECIFICALLY DIRECTED TO GEORGIA DEPARTMENT OF TRANSPORTATION SPECIFICATION SECTIONS 102.04, 102.05, AND 104.03 OF THE SPECIFICATIONS.
2. ALL WORK ASSOCIATED WITH THIS CONTRACT SHALL BE DONE IN ACCORDANCE WITH THE MOST CURRENT GEORGIA DEPARTMENT OF TRANSPORTATION STANDARD SPECIFICATIONS, SPECIAL PROVISIONS, CONSTRUCTION DETAILS, AND THE **ARCADIS U.S., INC. PLANS INCLUDED AS EXHIBIT A.**
3. THE CONTRACTOR SHALL PROVIDE POSITIVE DRAINAGE (WHERE APPLICABLE) SUCH THAT WATER DOES NOT POND ON FINISHED SURFACES.
4. THE CONTRACTOR SHALL BE RESPONSIBLE FOR MAINTAINING ALL DRAINAGE STRUCTURES WITHIN THE LIMITS OF THE PROJECT THROUGHOUT THE DURATION OF THE PROJECT. ANY DEBRIS THAT GOES INTO DRAINAGE STRUCTURES SHALL BE CLEANED OUT BY THE CONTRACTOR AT NO ADDITIONAL COST TO THE CITY.
5. TRAFFIC CONTROL SHALL BE PERFORMED IN ACCORDANCE WITH PART 6 OF THE 2009 MANUAL OF UNIFORM TRAFFIC CONTROL DEVICES FOR STREETS AND HIGHWAYS. A CERTIFIED FLAGGER WILL BE REQUIRED FOR THIS PROJECT.
6. THE CONTRACTOR WILL BE RESPONSIBLE FOR COORDINATING WITH DALTON UTILITIES AND OTHER UTILITY AGENCIES FOR THE COORDINATION AND ADJUSTMENTS (IF APPLICABLE) OF ALL UTILITIES LOCATED WITHIN THE PROJECT LIMITS.
7. CONTRACTOR IS REQUIRED TO CALL GA 811 OR FILE ONLINE A UTILITY LOCATE REQUEST PRIOR TO COMMENCING WORK AND MAINTAIN ACTIVE LOCATE FOR THE DURATION OF THE PROJECT.
8. TIME OF WORK RESTRICTIONS – NO WORK SHALL BE PERFORMED BETWEEN THE HOURS OF 5:30 PM AND 7:30 AM ON MONDAY THROUGH FRIDAY. CONSTRUCTION ON WEEKENDS SHALL BE PERMITTED ONLY BY WRITTEN APPROVAL UPON REQUEST BY CONTRACTOR TO THE CITY OF DALTON

PUBLIC WORKS PROJECT MANAGER, DIRECTOR, AND ENGINEER. DAMAGES FOR FAILURE TO OBSERVE TIME OF WORK RESTRICTIONS SHALL BE ASSESSED TO THE CONTRACTOR AT THE RATE OF \$200 PER HOUR.

9. COORDINATION OF PROJECT WITH OWNERS – CONTRACTOR SHALL CONTINUOUSLY MAKE A GOOD FAITH EFFORT TO COORDINATE WORK ACTIVITIES WITH THE ADJACENT PROPERTY OWNERS AFFECTED BY THE PROJECT.
10. NOTE: GRASSING COMPLETE SHALL INCLUDE STRAW, SLOPE MIX SEED, PERMANENT SEED MIX, FERTILIZER, OR SOD AS SPECIFIED.
11. CONTRACTOR IS REQUIRED TO FURNISH THE CITY AN AS-BUILT SURVEY OF THE IMPROVEMENTS FROM A LICENSED SURVEYOR UPON COMPLETION OF THE PROJECT. NO SEPARATE PAYMENT WILL BE MADE FOR THIS SURVEY AND THE EXPENSE SHOULD BE INCLUDED IN GRADING COMPLETE.
12. BECAUSE THE PROJECT CONSTRUCTION SITE IS LOCATED ON RESIDENTIAL STREETS AND ADJACENT TO OCCUPIED RESIDENCES, ALL CONSTRUCTION ACTIVITIES SHALL BE CONDUCTED IN SUCH A MANNER THAT WILL PROVIDE ACCEPTABLE LEVELS OF SAFETY AND MAINTENANCE OF UTILITIES, ROADWAY, TRAFFIC, DRIVEWAYS, SIDEWALKS, ETC. TO ALL OWNERS, CITY OF DALTON DEPARTMENT OF PUBLIC WORKS, MANAGEMENT, AND UTILITY COMPANIES. THE CONTRACTOR SHALL AT ALL TIMES MAINTAIN AND PROTECT ALL UTILITY SERVICES AND DRIVEWAY ACCESS, INCLUDING BUT NOT LIMITED TO, RESIDENTS, EMERGENCY SERVICES, VEHICLES, AND PEDESTRIAN TRAFFIC, ETC.
13. CONTRACTOR SHALL EXERCISE DUE DILIGENCE TO PERFORM THE WORK IN GOOD WORKMANLIKE MANNER. UPON COMPLETION OF THE WORK, THE RIGHT-OF-WAY AND PRIVATE PROPERTIES SHALL BE LEFT IN A CLEAN AND ORDERLY CONDITION, WITH ALL DEBRIS REMOVED THEREFROM, AND ANY AREAS WHICH MAY HAVE BEEN DISTURBED BY SUCH WORK SHALL BE RESTORED TO THEIR FORMER CONDITION AS NEARLY AS PRACTICABLE.
14. FINE GRADING LINE ITEM ON BID FORM ENCOMPASSES ALL SERVICES REQUIRED FOR FINISH WORK TO RESTORE DISTURBED PREVIOUSLY LANDSCAPED AREAS TO EXISTING CONDITIONS.
15. FOUR INCHES OF TOPSOIL IS REQUIRED PRIOR TO PERMANENT SEEDING AREAS THAT REQUIRE FINE GRADING.
16. CONTRACTOR WILL BE REQUIRED TO CONSULT THE CITY ARBORIST PRIOR TO ANY DISTURBANCE THAT ENCROACHES WITHIN ANY TREE DRIP LINES,

OR ANY CONCERNS REGARDING IMPACTS TO TREES AND SHRUBS THROUGHOUT THE COURSE OF CONSTRUCTION.

17. BUMP SIGNAGE – BUMP SIGNAGE SHALL BE INSTALLED ON ALL TRANSVERSE “BUTT” JOINTS CREATED AS A RESULT OF MILLING OPERATIONS. CONTRACTOR SHALL PLACE A WEDGE OF COLD MIX ASPHALT ON TRANSVERSE JOINTS AS A TEMPORARY MEASURE OF PROVIDING A SMOOTH TRANSITION TO PROJECT TIE-INS. THIS COLD MIX WEDGE SHALL BE REMOVED BY THE CONTRACTOR PRIOR TO COMMENCING RESURFACING. THE OWNER IS NOT RESPONSIBLE FOR DAMAGED VEHICLES CAUSED BY TRANSVERSE “BUTT” JOINTS.
18. THE CONTRACTOR SHALL PROVIDE POSITIVE DRAINAGE IN THE MILLING OPERATION SUCH THAT WATER DOES NOT POND ON THE ROADWAY.
19. MILLED AREAS SHALL BE COVERED WITH FINAL SURFACE COURSE WITHIN FOURTEEN (14) CALENDAR DAYS OF BEING MILLED. FAILURE BY THE CONTRACTOR TO COVER MILLED SURFACES WITHIN FOURTEEN (14) CALENDAR DAYS WILL RESULT IN LIQUIDATED DAMAGES TO BE ASSESSED AT A RATE OF \$200 PER DAY LEFT EXPOSED.
20. TEMPORARY STRIPING SHALL BE APPLIED IN PLACE OF ALL PREVIOUSLY EXISTING STRIPING PRIOR TO CONSTRUCTION WORK ENDING ON THE SAME DAY MILLING AND/OR RESURFACING WORK IS PERFORMED. TEMPORARY STRIPING TAPE SHALL BE PERMITTED.
21. ASPHALT OVERLAY FOR WEST FRANKLIN STREET AND VALLEY DRIVE SHALL ENCOMPASS THE FULL WIDTH TO EDGE OF PAVEMENT WITHIN THE PROJECT LIMITS OF DISTURBANCE.
22. ‘1.5” MILL FULL WIDTH (TO EDGE OF PAVEMENT OUTSIDE OF OPEN TRENCHING)’ ON BID FORM ENCOMPASS THE FULL WIDTH TO EDGE OF PAVEMENT WITHIN THE PROJECT LIMITS OF DISTURBANCE THAT ARE OUTSIDE OF THE OPEN TRENCHING AREAS FOR WEST FRANKLIN STREET AND VALLEY DRIVE.
23. ‘ASPHALT REMOVAL’ ON BID FORM ACCOUNTS FOR DEMOLITION OF EXISTING ASPHALT WITHIN THE LIMITS OF OPEN TRENCHING.
24. ‘TEMPORARY GAB TRENCH CAP’ QUANTITY ON BID FORM ACCOUNTS FOR A BACKFILL DEPTH OF 6 INCHES AT 95% COMPACTION.
25. EARTHWORK AND EXCAVATION (INCLUDING EARTHWORK SPOILS MATERIAL HAUL-OFF AND DEWATERING OF EXCAVATION, IF NEEDED) SHALL BE INCLUDED IN GRADING COMPLETE.

26. NOI – AN NOI IS REQUIRED FOR THIS PROJECT. CONTRACTOR SHALL OBTAIN NOI AND MAINTAIN NPDES INSPECTIONS AS REQUIRED BY THE STATE OF GEORGIA. A GSWCC CERTIFIED PERSONNEL BLUE CARD HOLDER MUST BE PRESENT ON SITE AT ALL TIMES TO REPRESENT THE CONTRACTOR.
27. A LOCAL LAND DISTURBANCE PERMIT IS REQUIRED TO BE FILED THROUGH WHITFIELD COUNTY. PLEASE CONTACT CHRIS HESTER, THE WHITFIELD COUNTY STORMWATER COORDINATOR, FOR INFORMATION REGARDING OBTAINING A LOCAL LAND DISTURBANCE PERMIT AT 706-281-1768.
28. RIGHT OF WAY/EASEMENTS: THE CONTRACTOR IS NOT RESPONSIBLE FOR SECURING EASEMENTS, AS THE CITY HAS ALREADY OBTAINED THEM.
29. CONTRACTOR SHALL BE REQUIRED TO REMOVE AND REPLACE THE EXISTING LANDSCAPE WALL LOCATED WITHIN THE LIMITS OF DISTURBANCE SHOWN ON SHEET C-07 WITHIN THE ISSUED FOR CONSTRUCTION PLAN SET.
30. CONTRACTOR SHALL BE REQUIRED TO REMOVE / RELOCATE WOODEN FOOT BRIDGE AS NEEDED WITHIN PROPERTY LIMITS SHOWN ON SHEET C-07 WITHIN THE ISSUED FOR CONSTRUCTION PLAN SET.
31. CONTRACTOR SHALL USE FIELD STONE FOR ALL STONE RIPRAP (REFER TO PHOTO BELOW) AS CALLED OUT IN THE ISSUED FOR CONSTRUCTION PLAN SET. REFER TO RIPRAP APRON SUMMARY CHART ON SHEET ESC-15 OF THE WEST FRANKLIN STREET BYPASS SYSTEM PLAN SET FOR SIZING DETAILS.
32. UNSUITABLE SOILS: CONTRACTOR SHALL BE REQUIRED TO CONTACT THE DESIGNATED CITY OF DALTON PUBLIC WORKS REPRESENTATIVE UPON ENCOUNTERING UNSUITABLE SOILS FOR VERIFICATION. CONTRACTOR SHALL BE REQUIRED TO MAINTAIN A DAILY LOG CONTAINING QUANTITIES OF UNSUITABLE SOILS ONCE ENCOUNTERED. DAILY LOGS SHALL BE MADE AVAILABLE FOR VIEWING BY THE PUBLIC WORKS DEPARTMENT AT ANY TIME UPON REQUEST. QUANTITIES ARE TO BE CONFIRMED BY THE PUBLIC WORKS PROJECT MANAGER PRIOR TO BILLING.
33. ROCK EXCAVATION: CONTRACTOR SHALL BE REQUIRED TO CONTACT THE CITY OF DALTON PUBLIC WORKS REPRESENTATIVE UPON ENCOUNTERING ROCK. ROCK EXCAVATION TO BE CONSIDERED ANY MATERIAL THAT CANNOT BE REMOVED BY A 40,000 LB. OR GREATER EXCAVATOR, OR EQUIPMENT OF EQUIVALENT SIZE. CONTRACTOR SHALL BE REQUIRED TO MAINTAIN A DAILY LOG OF ANY ROCK EXCAVATION OCCURRING CONTAINING AN ESTIMATED VOLUME OF ROCK BEING REMOVED. DAILY LOGS SHALL BE MADE AVAILABLE FOR VIEWING BY THE PUBLIC WORKS DEPARTMENT AT ANY TIME UPON REQUEST. QUANTITIES FOR ROCK

REMOVAL SHALL ALSO BE MEASURED AND CONFIRMED BY PUBLIC WORKS PROJECT MANAGER PRIOR TO BILLING.

34. FENCE REPLACEMENT: CONTRACTOR SHALL BE REQUIRED TO REMOVE AND REPLACE EXISTING FENCE AT 707 VALLEY DR. (IN LIKE KIND: VINYL COATED CHAIN LINK FENCE) AS REQUIRED DUE TO INSTALLATION OF NEW STORM SYSTEM.
35. EXISTING TREE SHOWN TO BE REMOVED ON PAGE C-08 OF THE ISSUED FOR CONSTRUCTION PLAN SET IS NOT TO BE REMOVED.

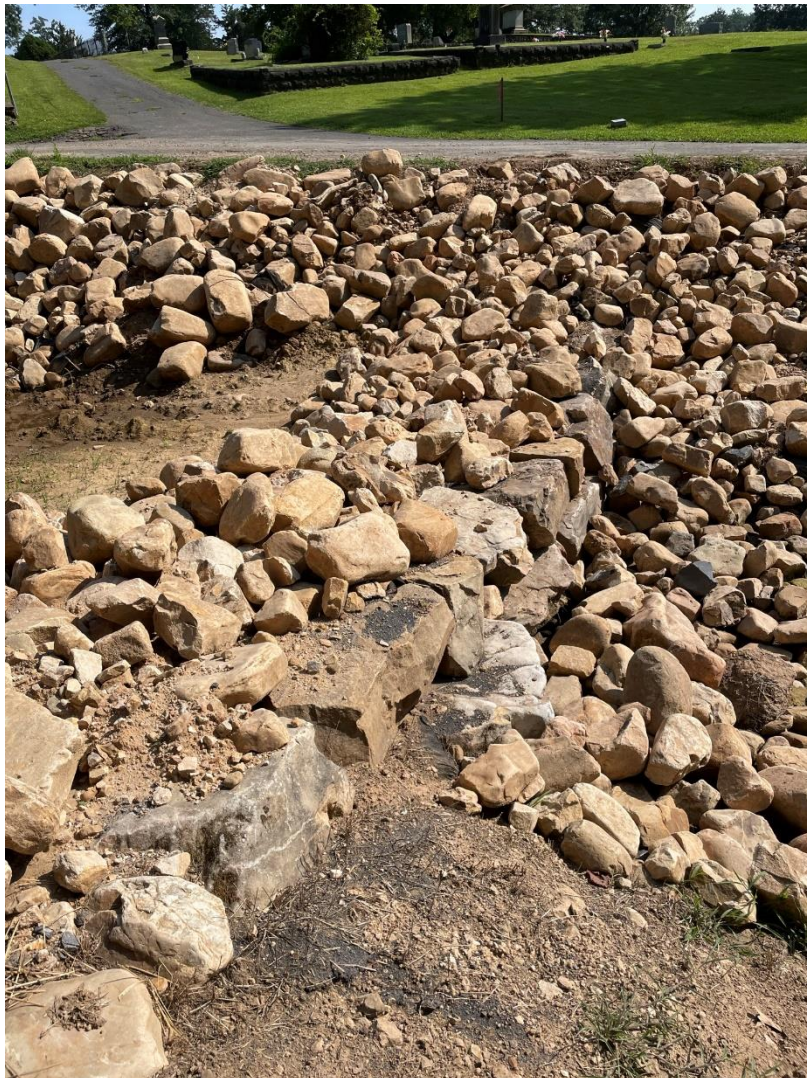

FIELD STONE VISUAL REFERENCE (REFER TO NOTE 31 FOR MORE DETAILS.)

EXHIBIT A:

***ARCADIS U.S., INC. SITE
DEVELOPMENT PLANS***

DATED OCTOBER 2024

FOR

***WEST FRANKLIN STREET BYPASS
SYSTEM***