

Mayor

Dr. Ianthia Fisher

Council

Mike Marsh, Mayor Pro Tem

Dennis Ivey, Pct. 1

Christopher Price, Pct. 2

NaTrenia Hicks, Pct. 3

Elbert Johnson, Pct. 4



City Administrator

Lee Standley

City Attorney

Donna Gordon

City Judge

Johnny Lawrence

City Secretary

Mitzi Stefka

December 15, 2025

Letter of Recommendation for Bid Award

Dear Mayor and Councilmembers:

Sealed proposal packets were received with a deadline of December 8, 2025 at 5:00 P.M. for gasoline and diesel fuel for city vehicles and equipment. One (1) sealed proposal was received.

The notification and advertising process for this bid included printed notices at City Hall and an advertisement in the local newspaper.

On Tuesday, December 9, 2025, the evaluation team comprised of City Manager, Lee Standley, Deputy City Administrator John Angerstein, and Program Manager, Butch Calvert met to review the proposals and issue a recommendation for award. From the review of the information provided in the sealed bid, Crockett Farm & Fuel is fully qualified and has excellent prior work performance with the city. Therefore, the evaluation team is recommending the city awarding the contract to Crockett Farm & Fuel.

Sincerely,

Lee Standley,

City Administrator

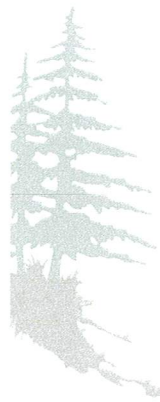

Paradise in the Pines

www.CrockettTexas.org
200 North Fifth Street
Crockett, Texas 75835
Office (936) 544-5156

ATTENDANCE SHEET

Sealed Bid Opening December 9, 2025, 2:00 PM
Fuel Bid

NAME

COMPANY REPRESENTING

SIGNATURE

BUTCH CALVERT



Lee Standley

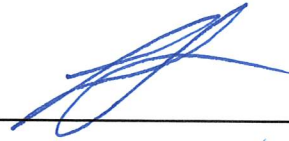

John Angerstein



EXHIBIT A: BID SHEET

I hereby offer for sale, to the City of Crockett, petroleum fuel products which meet or exceed your specifications: Prices effective for the time period listed in the contract.

PART 1 - FUEL

GASOLINE:

Regular Unleaded (87 or above octane):

Daily Rack Average plus a Constant Price of \$.50 per gallon.

Ethanol Free Unleaded Gasoline:

Daily Rack Average plus a Constant Price of \$.50 per gallon.

DIESEL FUEL (To meet ASTM specifications D396)

Off-Road (Dyed Diesel)

Daily Rack Average plus a Constant Price of \$.30 per gallon.

On-Road (Ultra Low Sulfur Diesel):

Daily Rack Average plus a Constant Price of \$.50 per gallon.

ADDITIONAL / OTHER SERVICES OFFERED WITH BID:

Company Name: Crockett Farm and Fuel TX LLC

Representative: Heath Woodford Title: Owner

Signature:  Date: 11/19/2025

The above price is good for 30 days.

Mayor

Dr. Ianthia Fisher

Council

Mike Marsh, Mayor Pro Tem

Dennis Ivey, Pct. 1

Christopher Price, Pct. 2

NaTrenia Hicks, Pct. 3

Elbert Johnson, Pct. 4



City Administrator

Lee Standley

City Attorney

Donna Gordon

City Judge

Johnny Lawrence

City Secretary

Mitzi Stefka

December 15, 2025

Information Letter of Bid Results

Dear Mayor and Councilmembers:

Sealed proposal packets were received with a deadline of December 8, 2025 at 5:00 P.M. for concrete curb and gutters. Two (2) sealed proposals were received.

The notification and advertising process for this bid included printed notices at City Hall and an advertisement in the local newspaper.

On Tuesday, December 9, 2025, the evaluation team comprised of City Manager, Lee Standley, Deputy City Administrator John Angerstein, and Program Manager, Butch Calvert met to review the proposals.

Site Utilities and Construction submitted a bid of \$25 per linear foot with a minimum of 400 feet of curb and gutter to be constructed.

Velazquez Brothers Construction submitted a bid of \$27 per linear foot with a minimum of 200 feet of curb and gutter to be constructed.

The evaluation team feels both firms are well qualified to do the work and has no preference between either firm.

Sincerely,

A blue ink handwritten signature of Lee Standley, consisting of stylized initials and a surname.

Lee Standley,

City Administrator

Paradise in the Pines

www.CrockettTexas.org
200 North Fifth Street
Crockett, Texas 75835
Office (936) 544-5156

ATTENDANCE SHEET

Sealed Bid Opening December 9, 2025, 2:00 PM
Concrete Curb/Gutter Bid

NAME

COMPANY REPRESENTING

SIGNATURE

BUTCH CALVERT



John Angerstein



Lee Standley

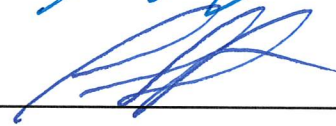
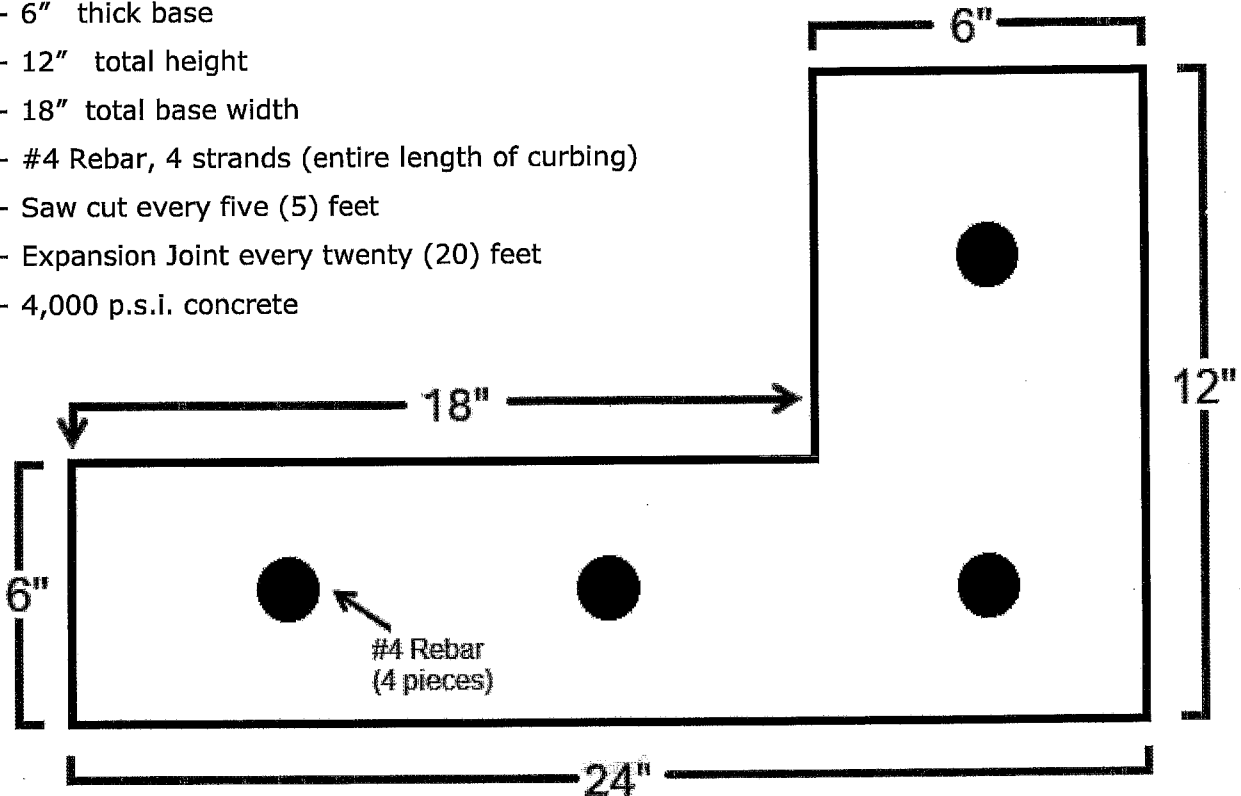

EXHIBIT A: BID SHEET

I hereby offer for sale, to the City of Crockett, products which meet or exceed your specifications:
Prices effective time period listed in the contract.

Curb and Gutter Specifications:

- 12" gutter width
- 6" curb width
- 6" curb height
- 6" thick base
- 12" total height
- 18" total base width
- #4 Rebar, 4 strands (entire length of curbing)
- Saw cut every five (5) feet
- Expansion Joint every twenty (20) feet
- 4,000 p.s.i. concrete



Total Price: \$ 25.00 per linear foot. Minimum 400 feet

Company Name: Site Utilities and Construction LLC

Representative: Blandy Palaoa Title: owner

Signature: [Handwritten Signature] Date: 12/18/2025

The above price is good for 365 days.

EXHIBIT A: BID SHEET

I hereby offer for sale, to the City of Crockett, products which meet or exceed your specifications:
Prices effective time period listed in the contract.

Curb and Gutter Specifications:

- 12" gutter width
- 6" curb width
- 6" curb height
- 6" thick base
- 12" total height
- 18" total base width
- #4 Rebar, 4 strands (entire length of curbing)
- Saw cut every five (5) feet
- Expansion Joint every twenty (20) feet
- 4,000 p.s.i. concrete

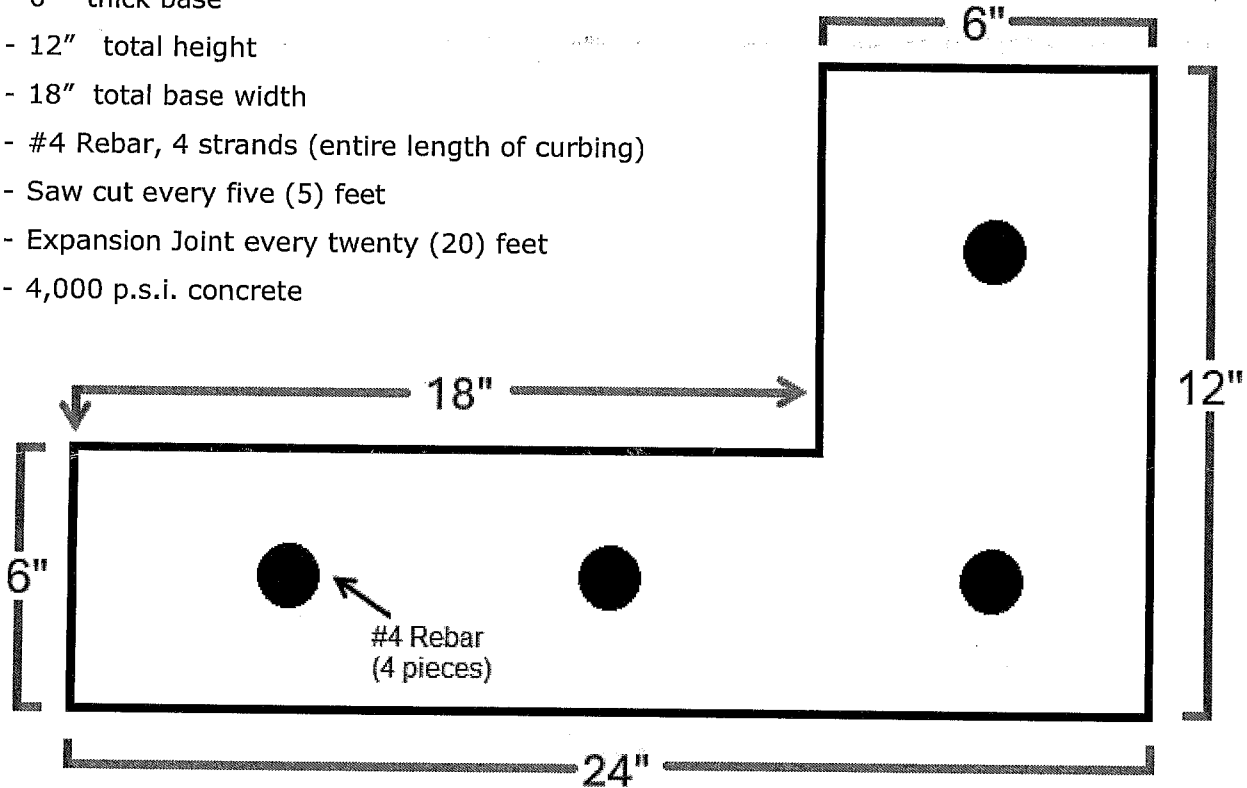

Total Price: \$ 27.00 per linear foot.

Company Name: Velazquez brothers Const. LLC

Representative: Luis Velazquez Title: owner

Signature: Luis Velazquez Date: 12-08-25

The above price is good for 365 days.

IF They are Less Than 200 feet of Curve
The price may change.