



521 Oak Leaf Court Unit A
Joliet, IL 60436
815-773-0808
FAX: 815-773-0812
LIC. 055-031454

TO: Don Seeman at City of Crest Hill

RE: Police Station Underground Issues

Date: July 9, 2026

We hereby propose to perform the following work according to the drawings and specifications that have been supplied to us for the above-mentioned project:

Inclusions:

- Ω **All work to be performed at regular hours, except sawcutting which will take place after 6:00 pm**
- Ω Floor Scan of sawcut area before cutting
- Ω Sawcutting and removal of concrete
- Ω Dust control and wall and floor protection set up prior to sawcutting
- Ω Reworking the double wye to be two single wye connections
- Ω Pour back of concrete with Barrier One Additive.
- Ω An add alternate has been provided below for adding a solenoid valve and timer to introduce water to a shower in both the men's and women's locker rooms to help with the lack of water coming from the current toilets. Price includes a solenoid valve, timer, piping, and insulation patching for each location.

Exclusions:

- Ω Roof, wall, or ceiling demolition. All roof, wall, or ceiling demolition by others.
- Ω Roof, wall, or ceiling patching or repair. All roof, wall, or ceiling patching by others
- Ω Epoxy Floor patching by others
- Ω Removing ceiling grid or tiles.
- Ω Insulation on existing piping
- Ω Gas piping, valves, regulators, outlets, or other gas equipment
- Ω Access Panels
- Ω Heat Tracing
- Ω Removal or remediation of any environmentally hazardous materials. Including, but not limited to any asbestos or lead containing materials. All hazardous material removal by others
- Ω Environmentally contaminated spoils
- Ω Supplying any dishwashers, refrigerators, or any other appliances
- Ω Condensate piping or providing any extra drains for condensate.
- Ω Dumpsters
- Ω Pipe Painting
- Ω Tap on, water meter, or permit fees

Change work orders will not be performed without written consent.

Payment to be made as follows: **Monthly Draws**

Should customer fail to pay pursuant to the terms of this contract, and Omega Plumbing, Inc. elects to take legal action to collect this amount, customer shall be responsible for reimbursement of all attorney's fees *(including contingency based percentages charged by attorneys)* and court costs incurred as a result of the enforcement of this contract

We will supply general liability and workers compensation insurance, fire and other insurance to be supplied by others.

The total cost for the work referenced above will be as follows:

Crest Hill Police Station Underground Issues	\$ 17,802.00
Add Alt 1: Add Solenoid Valve and Timer for Water Introduction	\$ 3,580.00

Respectfully Submitted,

Kevin Himmelman
Omega Plumbing
815-773-0808

Note: This proposal may be withdrawn by us in thirty days

We hereby accept the above proposal submitted to us by OMEGA PLUMBING and will commence the project within thirty days:

Signed: _____ Date: _____



Condensate Drain Valve Assemblies

2-way normally closed operation

Compact design

Adjustable timers with status indication



www.ascovalve.com



ASCO® Condensate Drain Valve Assemblies

Compressed air is used extensively in manufacturing and other processes to power various pneumatic equipment. When air is compressed, the temperature can typically rise to over 400°F. As the air in the system begins to cool, condensate is formed. This condensate, if not drained properly, will damage equipment and decrease the overall efficiency of your compressed air system. ASCO condensate drain valve assemblies are designed to effectively drain excess condensate from receiver tanks, pre-filters, separators, air dryers, and drip legs. By utilizing ASCO's proven solenoid and piloted piston valves, condensate drain valve assemblies will enhance the reliability and extend the life of your compressed air system.

Benefits

- Reduced on-site labor, installation time and assembly costs
- Compact design for use in small areas
- Adjustable timers with status indication and agency approvals
- Wide range of options and levels of assembly
- Proven ASCO solenoid valve design and quality
- Easy maintenance
- 1/4" to 1" NPT

Typical compressed air system diagram



Piloted Piston Series

ASCO's new range of clog-proof drain valves features the 8290 series piloted piston valve, known for its proven ruggedness and dependability. It is available in 3/8" to 1" NPT and features a 316 Stainless Steel body for durability and fluid compatibility. Because of its design, it is a zero maintenance valve which requires no condensate filter or strainer. The 8290 is an economical alternative to electric motorized ball drain valves.

Solenoid Series

ASCO's new condensate drain valve assemblies feature 2-way, normally closed solenoid valves with brass bodies. Their compact design saves space, simplifies service, and improves performance. A short stroke design allows for increased life of vital components. Each assembly features an adjustable, solid state timer with LED indicators and a Type 4 rating.

To calculate the volume of condensate that can be drained by the valve:

F_g = square root of pressure drop

$F_g \times C_v$ = GPM (Gallons Per Minute)

$GPM/60$ = GPS (Gallons Per Second)

$GPS \times 128$ = OPS (Ounces Per Second)

$OPS \times \text{On time of valve (seconds)}$ = DV (Drained Volume)

Construction

Valve Parts in Contact with Fluids			
Part	Solenoid Drain Valve	Piston Valve Solenoid Pilot	Piston Drain Valve
Body	Brass		316L Stainless Steel
Stem	-	-	316L Stainless Steel ①
Core Tube	Stainless Steel		-
Bonnet	Stainless Steel	Plated Steel	-
Core and Plugnut	Stainless Steel		-
Springs	Stainless Steel		-
Disc	NBR	FKM	316L Stainless Steel ②
Disc Seals	NBR	FKM	PTFE
Shading Coil	Copper		-
Stuffing Box	-	-	316L Stainless Steel
Stuffing Box Seal	-	-	PTFE
Wiper Seal	-	-	FKM
Screw	-	-	316L Stainless Steel ③

① 431 Stainless Steel for 50mm. ② Brass for 50mm. ③ No screw for 50mm.

Valve

Timer



Pilot Valve

Timer



Electrical

Standard Coil Class of Insulation	Watt Rating and Power Consumption				Ambient Temp. °F	DIN Spare Coil Family
	DC Watts	AC				
		Watts	VA Holding	VA Inrush		AC/DC
F	6.9	6.3	8.8	12.1	15 to 140	400125
F	9.2	9.2	14	23	15 to 140	ZA34A
F	5.5	4	6	12	15 to 140	4300
F	13	13	24	44	15 to 140	Z134A

Specifications (Assembly)

Inlet Pipe Size (Ins.)	Valve Outlet Pipe Size (Ins.)	Valve Orifice Dia. (Ins.)	Cv Flow	Condensate Drained (oz/sec.) ①	Operating Pressure Differential (psi)		Pilot Pressure (psi)	Assembly Number ②	Featured Assembly Components	
					Min.	Max.	Air or Water		Electrical Connections	Mechanical / Maintenance
							Range			
1/4 F	1/4 F	1/8	0.35	10	0	175	-	CDVA0JPJW5XCMLL CDVA0JPK1QZBSVN	-	-
									DIN to 6' cord w/N.A. plug	-
1/2 M ④	1/4 F	1/8	0.35	10	0	175	-	CDVA0JPL6ND5VR2 CDVA0JPLC7F5104	-	Manual Shutoff / Filter
									DIN to 6' cord w/N.A. plug	Manual Shutoff / Filter
3/8 F	3/8 F	7/16	1.99	56	5	175	-	CDVA138122AKBA8 CDVA13817MCJGKA	-	-
									DIN to 6' cord w/N.A. plug	-
1/2 M ④	3/8 F	7/16	1.99	56	5	175	-	CDVA1382CJSCKEQ CDVA1382J3UBQPS	-	Manual Shutoff / Filter
									DIN to 6' cord w/N.A. plug	Manual Shutoff / Filter
1/2 F	1/2 F	9/16	4.45	144	5	230	-	CDVA1MSH84LMV4U CDVA1MSHDPNM0DW	-	-
									DIN to 6' cord w/N.A. plug	-
1/2 M ④	1/2 F	9/16	4.45	144	5	230	-	CDVA1MSJJM2F39A CDVA1MSJQ64E8JC	-	Manual Shutoff / Filter
									DIN to 6' cord w/N.A. plug	Manual Shutoff / Filter
Pilot Operated Assembly - Normally Closed - with Pilot Valve and Timer										
3/8 F	3/8 F	3/8	2.3	76	0	240	60 to 150	CDVA5G5JCJP39FN CDVA5G5JJ3R2EQQ	-	DIN to 6' cord w/N.A. plug
									-	
1/2 F	1/2 F	1/2	4.1	117	0	180	60 to 150	CDVA60Q0JLZ5L7A CDVA60Q0Q614RGC	-	DIN to 6' cord w/N.A. plug
									-	
3/4 F	3/4 F	3/4	7.6	154	0	90	60 to 150	CDVA6K8GQP97PW0 CDVA6K8GW8B6V52	-	DIN to 6' cord w/N.A. plug
									-	
1 F	1	1	15	304	0	90	60 to 150	CDVA73790TM3NV6 ③ CDVA73796CP2U48 ③	-	DIN to 6' cord w/N.A. plug
									-	

① Volume of condensate drained per second at max operating pressure. ② Additional assemblies available through configurator. ③ Also available in bronze. ④ Manual Shutoff / Filter

Specifications (Solenoid Valve)

Pipe Size (ins.)	Orifice Dia. (ins.)	Cv Flow	Volume Drained per Second (oz/sec.) ①	Operating Pressure Differential (psi)			Max. Fluid Temp. °F	Brass	Wattage	
				Min.	Max. AC Water	Max. DC Water			AC	DC
1/4"	1/16"	0.11	5	0	435	435	195	SC8261S405	9.2	9.2
1/4"	3/32"	0.18	7	0	290	230	195	SC8261S406	9.2	9.2
1/4"	1/8"	0.35	10	0	175	60	195	SC8261S408	9.2	9.2
1/4"	5/16"	0.93	24	0	145	145	195	SC8261S413	9.2	9.2
3/8"	25/64"	1.75	45	0	145	45	195	SC8238S401	9.2	9.2
3/8"	7/16"	2.89	81	5	175	175	195	SC8238T402	4	5.5
1/2"	1/2"	2.46	63	0	145	45	195	SC8238S404	13	13
1/2"	9/16"	4.45	144	5	230	230	195	SC8238T405	4	5.5

① Volume of condensate drained per second at max operating pressure (AC).

Specifications (Piston Valve)

Pipe Size (ins.)	Orifice Dia. (ins.)	Cv Flow	Volume Drained per Second (oz/sec.) ①	Operating Pressure Differential (psi)		Max. Fluid Temp. °F	316 Stainless Steel	Air or Water Pilot Pressure (psi)	
				Min.	Max. Water			Min.	Max.
3/8"	3/8"	2.3	76	0	240	366	8290A791	60	150
1/2"	1/2"	4.1	117	0	180	366	8290A792	60	150
3/4"	3/4"	7.6	154	0	90	366	8290A793	60	150
1"	1"	15	304	0	90	366	8290A395	60	150
1"	1"	15	304	0	90	366	8290A386 ②	60	150

① Volume of condensate drained per second at max operating pressure. ② Brass/bronze body.

Specifications (Pilot Valve)

Pipe Size (ins.)	Orifice Dia. (ins.)	Cv Flow	Operating Pressure Differential (psi)			Max. Fluid Temp. °F	Brass	Wattage	
			Min.	Max. AC Air or Water	Max. DC Air or Water			AC	DC
1/8"	1/16"	0.09	0	140	140	180	SC8356A002V	6.3	6.9

Assembly Components

Assembly Part Numbers	Size	Drain Valve	Pilot Valve	Timer	Power Cord	Ball/Strainer
CDVA0JPJW5XCMLL	1/4"	SC8261S408 120/60	-	272839-001	-	-
CDVA0JPK1QZBSVN	1/4"	SC8261S408 120/60	-	272839-001	272852	-
CDVA0JPL6ND5VR2	1/4"	SC8261S408 120/60	-	272839-001	-	272851
CDVA0JPLC7F5104	1/4"	SC8261S408 120/60	-	272839-001	272852	272851
CDVA138122AKBA8	3/8"	SC8238T402 120/60	-	272839-009	-	-
CDVA13817MCJGKA	3/8"	SC8238T402 120/60	-	272839-009	272852	-
CDVA1382CJSCKEQ	3/8"	SC8238T402 120/60	-	272839-009	-	272851-002
CDVA1382J3UBQPS	3/8"	SC8238T402 120/60	-	272839-009	272852	272851-002
CDVA1MSH84LMV4U	1/2"	SC8238T405 120/60	-	272839-009	-	-
CDVA1MSHDPNM0DW	1/2"	SC8238T405 120/60	-	272839-009	272852	-
CDVA1MSJJM2F39A	1/2"	SC8238T405 120/60	-	272839-009	-	272851-003
CDVA1MSJQ64E8JC	1/2"	SC8238T405 120/60	-	272839-009	272852	272851-003
CDVA5G5JCP39FN	3/8"	8290A791	SC8356A002V 120/60	272839-009	-	N/R
CDVA5G5JJ3R2EQQ	3/8"	8290A791	SC8356A002V 120/60	272839-009	272852	N/R
CDVA60Q0JLZ5L7A	1/2"	8290A792	SC8356A002V 120/60	272839-009	-	N/R
CDVA60Q0Q614RGC	1/2"	8290A792	SC8356A002V 120/60	272839-009	272852	N/R
CDVA6K8GQP97PW0	3/4"	8290A793	SC8356A002V 120/60	272839-009	-	N/R
CDVA6K8GW8B6V52	3/4"	8290A793	SC8356A002V 120/60	272839-009	272852	N/R
CDVA73790TM3NV6	1"	8290A386	SC8356A002V 120/60	272839-009	-	N/R
CDVA73796CP2U48	1"	8290A386	SC8356A002V 120/60	272839-009	272852	N/R

Dimensions (Solenoid Series)

Assembly Number	A	B	C	D	E
CDVA0JPLC7F5104	3.99	3.33	3.79	1.95	5.48
CDVA1382J3UBQPS	4.93	3.29	5.39	3.35	5.40
CDVA1MSJQ64E8JC	4.93	3.29	5.39	3.35	5.40

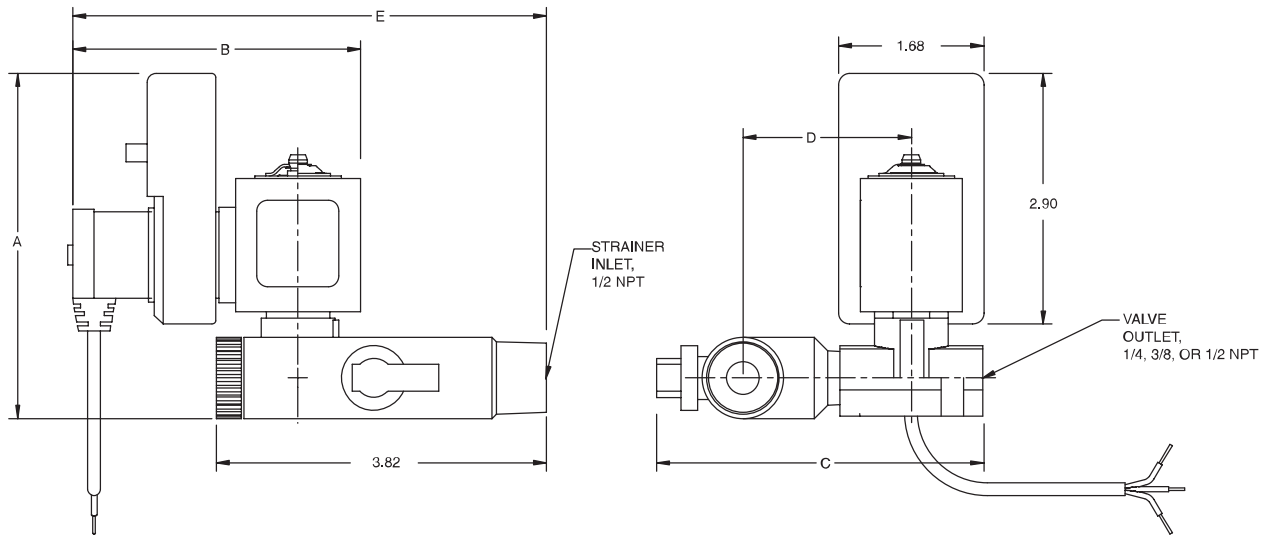

Dimensions (Piloted Piston Series)

Assembly Number	A	B	C
CDVA5G5JJ3R2EQQ	3.82	5.16	3.99
CDVA60Q0Q614RGC	3.82	5.16	3.99
CDVA6K8GW8B6V52	3.82	5.16	3.99
CDVA73796CP2U48	4.70	6.56	5.43

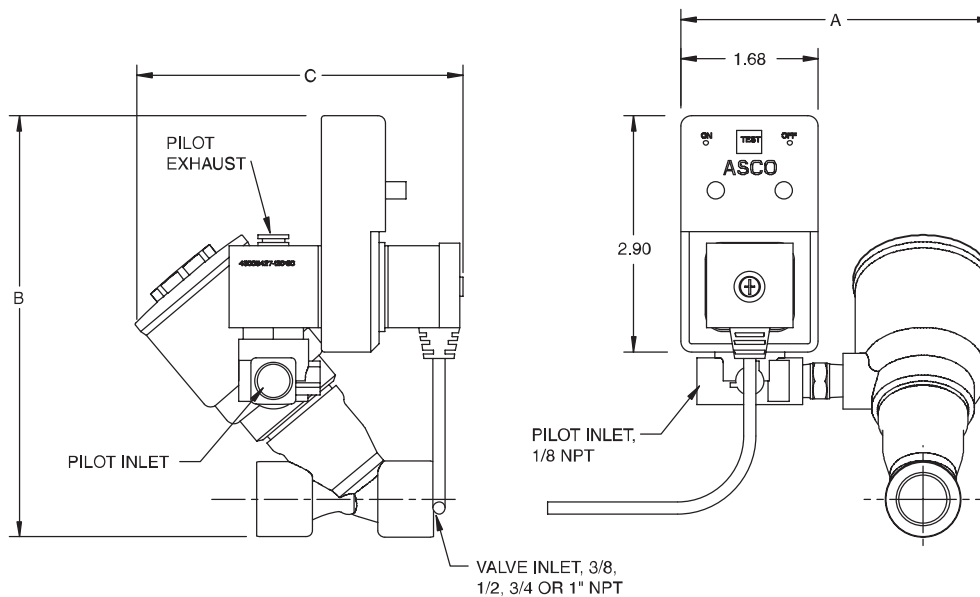

Timer

Timing Ranges:

Standard: On: 2 sec. to 40 sec.
Off: .5 min. to 45 min.

Optional: On: .5 sec. (minimum), 45 min. (maximum)
Off: 2 sec. (minimum), 4 hours (maximum)

All solid state, no moving parts to wear

Manual override for testing/resetting

UL, CE approvals

Type 4 rated

MOV voltage suppression

LED status lights

Ambient temperature range: 14°F to +122°F



Power Cord

Allows for easy connection to AC wall outlet

UL recognized

Other termination types available upon request

	Specification	Construction
Cord	6 Feet Long	PVC Outer Jacket
Conductor	3 x 18 AWG	-
Contacts	-	Silver Plated Brass
Plug Housing	3 Prong North American	Nylon
Max. Power Rating	5 amp	-
Max. Voltage Rating	250 V	-
Environmental Rating	TYPE 1,3,4 / IEC IP67	-
Terminal Seal Gasket	-	NBR

Manual Shutoff / Filter

Prevents debris from clogging valve

Hand turn isolation valve for maintenance of strainer or drain valve

Knurled strainer screen end cap for easy maintenance

Brass body



	Specification	Construction
Max. Pressure (psi)	290	-
Max. Temp. (F)	230	-
Mesh Strainer	40 Micron	Stainless Steel
Manual Shutoff Handle	1/4 Turn	Chrome Plated ABS
Ball Seal	-	PTFE
End Cap Seal	-	NBR

ASCO® Condensate Drain Valve Assembly Configurator

ASCO simplified the condensate drain valve assembly selection process with an online catalog number configurator. Once you have determined the required features, you can easily construct a catalog number by clicking on each feature and then clicking the View Details button. A second screen will appear, which provides the product catalog number, product attributes, and 3D CAD models. The configurator is programmed to accept only valid constructions.

In addition to creating a catalog number, the configurator can also decipher a catalog number. Type a valid CDV catalog number into the window next to the Enter Catalog Number button. The configurator automatically highlights the appropriate construction features.

In order to use the online configurator go to: www.ascovalve.com/CDVConfigurator

Design a Condensate Drain Valve Assembly

★ Indicates a required attribute.

<p>★ Drain Valve Type</p> <p>Solenoid Operated Drain Valve</p> <p>Piloted Piston Drain Valve</p>	<p>★ Pipe Size</p> <p>1/4"</p> <p>3/8"</p> <p>1/2"</p> <p>3/4"</p> <p>1"</p>	<p>★ Timer On Range</p> <p>0.5 Sec Fixed</p> <p>30 Sec Fixed</p> <p>0.5 to 10 Sec</p> <p>2 to 40 Sec</p> <p>0.25 to 10 Min</p> <p>0.3 to 30 Min</p> <p>0.5 to 45 Min</p>	<p>★ Voltage</p> <p>24/60Hz AC</p> <p>120/60Hz AC</p> <p>240/60Hz AC</p> <p>12 DC</p> <p>24 DC</p>
<p>★ Maximum Operating Pressure</p> <p>30 psi</p> <p>45 psi</p> <p>60 psi</p> <p>90 psi</p> <p>105 psi</p> <p>130 psi</p> <p>170 psi</p> <p>230 psi</p> <p>290 psi</p> <p>435 psi</p>	<p>★ Drain Valve Body Material</p> <p>Brass/Bronze</p> <p>Stainless Steel</p>	<p>★ Timer Off Range</p> <p>2 to 40 Sec</p> <p>0.5 to 45 Min</p> <p>0.25 to 4 Hrs</p>	<p>★ Valve Elastomer</p> <p>NBR</p> <p>FKM</p> <p>PTFE</p>

Optional Components

Power Cord Set - DIN 3 Prong Plug
NA Plug
NA Plug w/ 180 Ground
Blunt
Tinned and Stripped

Information

Hover the mouse over a field for additional information about that field.



Min/Max Ambient Temperature: 15°F - 180°F

Min/Max Fluid Temperature: 32°F - 180°F

Minimum Operation Pressure: Solenoid 5 psi, Piston 0 psi

Piston Valves Standard with PTFE Elastomers

Strainer Inlet size 1/2" NPT External

Pilot Valve Operating Pressure: 60-150 psi

www.ascovalve.com

Canada
Tel 519-758-2700

Australia
Tel (61) 2-9-451-7077

Brazil
Tel (55) 11-4208-1700

Mexico
Tel (52) 55-3640-0200

France
Tel (33) 1-47-14-32-00

Germany
Tel (49)-7237-9960

United Kingdom
Tel (44) 1695-713600

China
Tel (852) 2-343-8580

Singapore
Tel (65) 6556-1100

Japan
Tel (81) 798-65-6361

ASCO Valve, Inc. • 800.972.2726 • www.ascovalve.com

V7651R2

Features

- Solid state electronic timer used to automatically control ASCO solenoid valves
- Typically used with ASCO Solenoid Valves for automatic draining of condensate in compressed air systems
- Selectable timing ranges (2-40 seconds "on"; 30 seconds to 45 minutes "off")
- Manual override for test/reset
- LED lights to indicate timing phase

Technical Specifications

Supply Voltage	24 - 240V AC/DC 50/60 Hz
Current Consumption	4 mA max.
Operating Temperature	14°F - 122°F
Environmental Protection	Type 4
Switch Capacity	1 Amp
Inrush Current Capacity	10 Amps for 10 mSec
Duty Cycle	100%
Repeat Accuracy	± 0.1%
Scale Accuracy	± 10%
Reset/Test	Manual Touch Switch
Printed Circuit Board	UL 94V0
Connection	DIN 43650 ISO-4400/6952
Indicators	LEDs to indicate phases
On Time	Adjustable from 2 to 40 sec.
Off Time	Adjustable from 30 sec to 45 min.



Timer and Accessories Kit Numbers

Timer Catalog Number:	272839-001 272839-009**
Power Cord* Kit Number:	272852
DIN Connector Kit Number:	272873
* 6' power cord has DIN connector and 3-prong plug for wall outlet. ** For use with DIN 11 CDV Assemblies.	

Dimensions inches (mm)

