



Equipment Proposal

This Equipment Proposal (the "Proposal") has been prepared by Ten-8 Fire & Safety, LLC ("Company") in response to the undersigned Customer's request for a proposal. This Proposal is comprised of the special terms set forth below, the Proposal Option List (or for ambulance sales, the Quotation, or Order Form, as applicable), Warranty, and Company's Purchasing Terms and Conditions. Through its signature below or other Acceptance (as defined below), Customer acknowledges having received, read and being bound by this Proposal, all attachments and Company's Purchasing Terms and Conditions.

Date: December 2, 2021 ("Proposal Date") **Customer:** Cooper City ("Customer")

Customer Address: 10550 Stirling Road, Cooper City, FL 33328

Quantity	Product Description & Options	Price
1	One 2022 Osage Super Warrior Type 1 Medium Duty Ambulance built on a 2023 Freightliner M2 chassis per BSO Contract RLI # 18007IC	\$414,783.00
Purchase Price:		\$414,783.00

Delivery Timing: The Product described above in the Product Description and Options Section of this document will be built by and shipped from the manufacturer approximately 20 (months) after Company receives Customer's acceptance of this Proposal as defined below.

Other: Lead-time quoted is based on current chassis/supply chain issues and may change

Unless accepted within 60 days from date of proposal, the right is reserved to withdraw this proposal.

ACCEPTANCE OF THIS PROPOSAL CREATES AN ENFORCEABLE BINDING AGREEMENT BETWEEN COMPANY AND CUSTOMER. "ACCEPTANCE" MEANS THAT CUSTOMER DELIVERS TO COMPANY: (A) A PROPOSAL SIGNED BY AN AUTHORIZED REPRESENTATIVE, OR (B) A PURCHASE ORDER INCORPORATING THIS PROPOSAL, WHICH IS DULY APPROVED, TO THE EXTENT APPLICABLE, BY CUSTOMER'S GOVERNING BOARD. ACCEPTANCE OF THIS PROPOSAL IS EXPRESSLY LIMITED TO THE TERMS CONTAINED IN THIS PROPOSAL AND COMPANY'S PURCHASING TERMS AND CONDITIONS. ANY ADDITIONAL OR DIFFERENT TERMS, WHETHER CONTAINED IN CUSTOMER'S FORMS OR OTHERWISE PRESENTED BY CUSTOMER AT ANY TIME, ARE HEREBY REJECTED.

INTENDING TO CREATE A BINDING AGREEMENT, Customer and Company have each caused this Proposal to be executed by their duly authorized representatives as of date of the last signature below.

Customer: Broward Sheriff's Office Fire Rescue

Ten-8 Fire & Safety, LLC

By: _____

By:

Title: _____

Title: **Authorized Sale Representative**

Print: _____

Print: Michael Day

Date: _____

Date: December 2, 2021

EXHIBIT A

PROPOSAL OPTION LIST
(OR FOR AMBULANCE SALES, THE QUOTATION, OR ORDER FORM, AS APPLICABLE)

Dealer Name: **Ten-8 Fire & Safety**
 Salesperson: **Michael Day**
 Customer Name: **Broward Sheriff's Office Fire Rescue**
 & Address: **2308-B S.W. 42nd Street**
 Shipping Address: **Broward Sheriff's Office Fire Rescue**
 Fleet Number: _____
 Contact Name: **Victor Goizueta - Fire Rescue Fleet Coordinator**
 Email: victor_goizueta@sheriff.org
 Phone: **Office: 954-359-1602 Mobile: 954-864-9431**
 Fax: _____
 Chassis Type: **Freightliner M2 Standard Cab**
 Osage Unit #: _____

Qty		Freightliner M2 Chassis and Conversion		Total
1		2023 Freightliner M2 Chassis only, see attached specifications	\$105,911.11	\$95,320.00
1		2168/Freightliner Med-Duty Conversion	\$166,921.11	\$150,229.00
		Warning & Intersection Lights, Wig-Wag		
16	W-03	Chrome Flanges for M9	\$355.56	\$320.00
11	W-04	Chrome Flanges for M6 or M7	\$183.33	\$165.00
		Premption Custom Lightbars		
2		"Whelen Mini-Freedom, (2), Angle Mounted on Cab Roof. All Clear Lenses. (1) Angle mounted on street side cab roof, as outboard as possible, as far forward as possible (1) Angle mounted on curb side cab roof, as outboard as possible, as far forward as possible. SWITCHED: FRONT LB White lights only Disabled in park / neutral "	\$4,472.22	\$4,025.00
20		Whelen Tracer Lighting System (12" Sections) 75" between front of module and rear wheels and rear of each module side. Function to include alternate red/white activation with emergency warning priority, and all white activation with any compartment door and curbside door opening.	\$4,677.78	\$4,210.00
		Directional Sticks		
1	W-09	Whelen TAL 85 LED 8 Light Traffic Advisor	\$1,105.56	\$995.00
		Whelen Smart Linear LED's		
2	W-29	Additional 500 LED, R, B or A (Outboard on Aux. Condenser Module Front)	\$377.78	\$340.00
1	W-31	Additional 500 LED, All or 1/2 Clr (Center on Aux. Condenser Module Front)	\$238.89	\$215.00
2	W-32	Upgrade 900 to M9 LED, R (3 Front, 2 Rear, 8 Module Sides)	\$450.00	\$405.00
1	W-33	Upgrade 900 to M9, Amber, Blue, R/B, R/A (Amber - Rear module @ window level)	\$50.00	\$45.00
1	W-35	Additional M9, Red	\$322.22	\$290.00
1	W-36	Additional M9, B, A, R/B, R/A (Amber - rear module @ window level)	\$366.67	\$330.00
2	W-38	Upgrade ION-T to M6 Red (Front Grille of Cab)	\$155.56	\$140.00
2	W-41	Additional M6 LED, R, B or A (2 @ rear module kick plate)	\$488.89	\$440.00
2	W-44	Upgrade ION-T to M7 R, B or A (Red, cab intersection)	\$144.44	\$130.00
5	W-47	Additional M7 LED, R, B or A (red, rear module above TAL85) (Amber - Center Rear Module)	\$1,111.11	\$1,000.00
8	W-51	Whelen OS Light (Amber Whelen OS flashing lights on interior of rear facing doors)	\$400.00	\$360.00
8	W-52	Add Any Light to Interior of Door (Add to Light Price)	\$355.56	\$320.00
		Scene Lights		
4	W-56	M9 LED Scene, Upgrade	\$555.56	\$500.00
2	W-58	M7 LED Scene, Upgrade	\$222.22	\$200.00
2	W-61	Spot & Flood w/Flange, Add FRC Spectra Max SPA260-Q20-B	\$3,844.44	\$3,460.00
1	W-64	Upgrade Brake/Tail to M6 (Pair)	\$55.56	\$50.00
1	W-65	Upgrade Turn to M6 (Pair)	\$100.00	\$90.00
1	W-66	Upgrade Reverse to M6 (Pair)	\$111.11	\$100.00
		Siren & Speakers		
1	W-77	Whelen Howler (Only Available w/ Whelen Siren)	\$1,188.89	\$1,070.00
		Exterior Lighting		
1	W-81	M6 Turn Lights w/Chrome Flanges on Front of Mod (per pair)	\$477.78	\$430.00
1	W-89	Techniques E-41 LED Strip Lighting in all Compartments	\$750.00	\$675.00
		Additional Emergency & Exterior Lighting & Siren Options & Special Instructions		
1		""""*Whelen Howler installed, IATS, behind front bumper. *Activation/Cancellation 3-position momentary rocker switch installed on center console beside std. siren control in reach of driver. *Label: Activate-Howler-Cancel Customer wants to use OEM airhorn switch on steering wheel to activate howler. Airhorns will be wired to driver side footswitch and push button in console. Set Howler duration on maximum.""	\$266.67	\$240.00
2		Rear module outboard M9's Changed to Whelen Rota Beam 6RBC. Synced to each other.	\$1,211.11	\$1,090.00
1		DELETE standard siren. ADD Whelen WS295SLSC1	\$355.56	\$320.00
2		Amber M9's at rear windows wired as flashing lights with turn signal override	\$200.00	\$180.00
		Inverters, Chargers, Batteries, Shorelines & Outlets		
1	E-03	Vanner Inverter / Conditioner w/ Remote Switch, Model 20-1050-CUL NOTE: Bluesea Auto Eject Shoreline Plug, 20 Amp (Module Rear) Red above left tail light. Blue for 110 vac system above left tail light.	\$1,750.00	\$1,575.00
2	E-10	NOTE: Larger Auto Eject Access	\$1,088.89	\$980.00
2	E-12	Shoreline Indicator at Shoreline	\$444.44	\$400.00
		Outlets & Interior Lighting		
3	E-13	110 V Outlet, Additional per Outlet (rear wall at foot of S/B, in action wall, in Danhard cabinet)	\$316.67	\$285.00
2		12V DC Outlet, Cigar Style, Additional per Outlet Note: Ignition Switch hot (1) next to 110vac outlets in action wall, (1) in right wall	\$133.33	\$120.00
3	E-16	Dual USB Outlet (1) Located on the passenger side of the center console. (1) Front console facing dash, right side low, (1) in action area.	\$266.67	\$240.00

1	E-23	Power Door Lock Control Head	\$533.33	\$480.00
8	E-24	Power Door Lock Per Door (includes #3)	\$1,244.44	\$1,120.00
2	E-26	Whelen Round LED Domelights w/Chrome Flange (Upgrade per Lt)	\$150.00	\$135.00
1	E-29	Additional Dome Lights (Above curbside entry door stepwell)	\$166.67	\$150.00
Switches & Secure Idle				
1	E-35	Hidden Switch in Grill for Door Locks (tie cab and module locks together)	\$194.44	\$175.00
Pre-wires, Radios, Intercom, & Clocks				
4	E-38	Antenna Pre-Wire, (additional per Pre-Wire)	\$177.78	\$160.00
		Install Customer Radio Cable (each)		
2	E-40	Note: Specify Brand of Radio Cable:	\$333.33	\$300.00
3	E-41	Install Customer Antenna (each)	\$500.00	\$450.00
2	E-42	Install Customer Radio Head (each)	\$555.56	\$500.00
1	E-43	Two Radio Speakers in Patient Compartment (note 4 speaker wiring per J2752)	\$194.44	\$175.00
1	E-44	Volume Control for Rear Speakers Mounted in Action Area	\$133.33	\$120.00
1	E-46	Carbon Monoxide Monitor	\$194.44	\$175.00
ELECTRICAL OPTIONS				
V-Mux Options				
1	E-47	Warning Lights in Secondary w/Park Brake or Park ("Park" n.a. on some chassis')		nc
1	E-48	Park Brake Override Switch		nc
1	E-49	Full Set of Diagnostic Screens (w/Vista IV Upgrade Only)		nc
1	E-50	Truck Information Screen (w/Vista IV Upgrade Only)		nc
1	E-51	Up to 10 Intensities on Dome Lights (Off-Hi-Lo is Standard)		nc
1	E-52	Up to 10 Speeds on Exhaust Fans (Off-On is Standard)		nc
1	E-53	Up to 10 Speeds on HVAC Fan		nc
1	E-54	Custom Flash Patterns (Specify on Page 9)		nc
1	E-55	Rear Flashers on in Reverse (Specify on Page 9)		nc
1	E-56	Side Scene on in Reverse		nc
1	E-57	Brake Override		nc
1	E-58	Custom Load Sequencing (On or Off) (Specify on Page 9)		nc
1	E-59	Custom Load Shedding (Specify on Page 9)		nc
1	E-60	Upgrade Switches to Vista IV Screens	\$3,772.22	\$3,395.00
1	E-63	Reverse Camera Tied into V-MVX Screen (w/Vista IV Upgrade Only)	\$572.22	\$515.00
1	E-64	O2 Sensor for V-MVX System (Requires Ordering M-15) (w/Vista IV Upgrade Only)	\$500.00	\$450.00
1	E-65	Exterior Temperature Readout (w/Vista IV Upgrade Only)	\$150.00	\$135.00
1	E-66	Ammeter Readout (w/Vista IV Upgrade Only)	\$516.67	\$465.00
HVAC Systems				
1	E-68	Danhardt 110V Cool Unit WITH PLENUM AND DUCTS (AC only, NO Heat)	\$5,122.22	\$4,610.00
1	E-70	Norcold 1.7 cubic feet Refrigerator	\$1,300.00	\$1,170.00
1	E-76	Upcharge to Install Condensor on Front of Module	\$583.33	\$525.00
1	E-77	Rooftop-Mount Condenser	\$1,944.44	\$1,750.00
Mirrors, Hind-Sight, Backup Camera, & Spotlights				
1	E-80	Hind-Sight Sonar Backup Assist	\$916.67	\$825.00
ELECTRICAL OPTIONS				
Additional Electrical Options & Special Instruction				
1		Atomic Clock on rear wall	\$61.11	\$55.00
1		Firecom and arrowstick controls moved overhead	\$388.89	\$350.00
1		Rear module and rear-most side warning lights to activate when unit placed in reverse.	\$100.00	\$90.00
1		High idle on with warning lights and emergency brake	\$138.89	\$125.00
1		Center rear amber light to flash with warning lights and when unit is in park.	\$50.00	\$45.00
1		Secret switch to interlock with shifter	\$416.67	\$375.00
1		"All rear amber lights: Center rear amber is on warning light switch. Amber lights to come on when ignition on and unit in neutral/park brake set. Disable when placed in gear."	\$50.00	\$45.00
1		Move Liquid Spring control to top #1 compartment	\$111.11	\$100.00
Auto Secondary, Neutral Safety, Custom				
1		To automatically shut off the following lights when vehicle transmission is placed in park: center white light, and white lights in lightbars on cab roof. Circuit still gets the warning light switch & secondary override. The secondary override switch is for the center white light. White lights in lightbars will stay off until vehicle is placed back into gear.	\$100.00	\$90.00
Automatic Secondary, Neutral, W/ Switch				
1		Auto secondary to shut off center white light, (4) grille lights, and (2) front intersection lights, when vehicle is placed in neutral.	\$200.00	\$180.00
1		Liquid Spring to function when battery switch is on but ignition is off	\$100.00	\$90.00
1		Rear A/C to come on full cool and high fan when truck is started	\$100.00	\$90.00
1		Two additional key fobs	\$388.89	\$350.00
1		Outlet, 110 VAC, 16" Power Strip in action area per drawings.	\$222.22	\$200.00
1		Master Switch Hot in center console for spotlight	\$83.33	\$75.00
1		Power Source, 12 VDC, 20 Amp ignition hot behind driver seat		
		"Power Source, 12 VDC, 30 Amp (+-) (1) Ignition Hot, to terminate in center console, at buss bars, (hot and ground). (1) Constant Hot, to terminate behind Str/s A/A, w/6 foot tails (hot and ground). (1) Ignition Hot, to terminate behind Str/s A/A, w/6 foot tails (hot and ground)."		
1		"Power Source, 12 VDC, 30 Amp (+-) Constant Hot, to terminate in center console, at buss bars, (hot and ground)."		
2		Buss Bars, 5 Position, (2 Each) inside cab console, for 30amp power source	\$144.44	\$130.00
1		NOTE: Spotlight wire to come from behind passenger seat	\$100.00	\$90.00
1		Set of LED Bumper Pole Markers. Bore, Lighted	\$388.89	\$350.00
3	A	HARD WIRED Key Pad for Power Lock System	\$2,833.33	\$2,550.00

1	E-39: Install customers antennas: (1) Front cab roof to passenger seat. (1) From left front corner of mod roof to passenger seat. (1) GPS antenna from cab roof to front console.		
1	E-38: Run customer radio cables: (1) Service panel to passenger seat. (1) Front console to passenger seat.		
1	E-40: Mount customer radio heads: (1) in action area (1) trunk mount behind passenger seat.		
1	Install customer supplied Firecom System per drawings	\$777.78	\$700.00
1	Install Pro Air UV light in duet work	\$400.00	\$360.00
1	Aluminum Brush Guard for reverse camera	\$166.67	\$150.00
1	NOTE: 2 Minute Timer		
1	NOTE: Engraved Placards I.L.O. Stickers	\$388.89	\$350.00
1	Kussmaul 091-28 Air Eject on Rear of Module	\$416.67	\$375.00
	I.V. & Suction		
1	M-04 Sscor VX-2 Portable / Permanent Suction I.L.O. Standard	\$900.00	\$810.00
	Cot Mounts		
1	M-09 Stryker Power Load I.L.O. Performance Load	\$27,183.33	\$24,465.00
	Oxygen		
1	M-15 Additional O2 Outlet Over Squad Bench	\$194.44	\$175.00
1	M-16 O2 Regulator for "M" Tank	\$155.56	\$140.00
1	M-19 Electric O2 Solenoid w/Switch	\$433.33	\$390.00
	Additional Medical Options & Special Instructions		
2	IV Hook, Perko, W/Straps Mount at delivery	\$66.67	\$60.00
1	NOTE: COT Mount to be 16" from Center to left wall. - Mount forward from normal postion. See Drawings.		
1	NOTE: Install Stryker Decals per previous truck location.		
	Laminate & Vinyl		
1	I-02 Custom Vinyl Color	\$222.22	\$200.00
1	Zolatone Color: 20-62 MARBLESTONE		
1	Vinyl Color: MV-102 GUNMETAL		
1	Lonplate Color: #424 GUNMETAL		
	Flooring, Aisle, Backboard Slots		
1	I-06 Composite Subfloor	\$861.11	\$775.00
	Seating, Squad Bench, EMT, CPR		
1	I-07 Swivel Pedestal for EVS Attendant Seat	\$500.00	\$450.00
1	I-12 5-Pt. Child Seat	\$1,077.78	\$970.00
2	6-Point Seat Belt, Per Position Note: Specify Color (If no color is chosen, black will be provided: Black XX Orange Red Yellow	\$1,088.89	\$980.00
	Cabinetry, Windows, Marker Boards, Shelves, & HVAC Ducts		
1	I-30 Customize Console in Type I	\$150.00	\$135.00
1	I-32 Aluminum Cabinetry (Requires Spray Coating)	\$7,333.33	\$6,600.00
2	I-44 Tilt-up Speed Load Cabinet Windows, w/latch NOTE: 2 latches per window. Above Action Area	\$566.67	\$510.00
2	I-45 Interior Access to Exterior Compartment	\$833.33	\$750.00
2	I-51 Track-Type Adjustable Shelves in Interior Cabinets, (per shelf) above action area	\$166.67	\$150.00
1	I-59 Glove Storage Over Side Entry Door	\$416.67	\$375.00
	Doors, Locks, & Latches		
13	I-71 Southco Stainless Steel Latches, (per Latch)	\$433.33	\$390.00
	Counter Tops		
1	I-74 Speckled Color Finish in Silk Stone Action Area Countertop	\$550.00	\$495.00
1	Stainless Steel Counter Top with 1 1/2" Vertical Lips	\$944.44	\$850.00
	Sharps, Waste, & Drawers		
4	I-85 Drawer for General Storage (Curbside per drawing)	\$1,555.56	\$1,400.00
	Grab Rails & Bars, Armrests		
1	I-88 Additional Grab Rail Over Squad Bench	\$300.00	\$270.00
1	I-93 12" Stainless Grab Handle (Side entry door)	\$111.11	\$100.00
7	I-94 Make Grab Bar Yellow (Price Each)	\$544.44	\$490.00
	Insulation & Sound Deadening		
1	I-96 3M Sound Deadening on Back of Exterior Compartments	\$555.56	\$500.00
	Additional Headroom, Crawl Through (Type I), Bariatric Package		
1	I-98 Custom Headroom. Fill in Height 74"	\$666.67	\$600.00
1	I-99 Crawl Through to Cab, (Type I) match previous	\$1,333.33	\$1,200.00
	Additional Interior Options & Special Instructions		
1	Yellow/Black non skid tape. Match previous	\$33.33	\$30.00
1	NOTE: Console to be Aluminum	\$777.78	\$700.00
1	Cabinet at head of bench	\$666.67	\$600.00
1	Move Vent to right side	\$100.00	\$90.00
1	Center Attendant seat with COT	\$100.00	\$90.00
1	Custom horizontal HVAC mounted at angle in bulkhead	\$1,388.89	\$1,250.00
3	Stainless Steel Cot Plates (SILICONE AROUND EDGES OF THESE PLATES AND DOOR THRESHHOLDS)	\$416.67	\$375.00
1	1" Lip on Right Wall Counter	\$83.33	\$75.00
2	Build HVAC Cabinet for 12 x 12 x 1 Intake Filter	\$222.22	\$200.00
3	6" Oracal Chevrons on entry door kick plates	\$500.00	\$450.00
3	Rubber mats on all cabinet shelves	\$166.67	\$150.00
3	Dry Deck on floor of left wall cabinets	\$333.33	\$300.00
1	NOTE: DO NOT angle cabinet over action area		

2	Glover Butlers (Match previous)	\$133.33	\$120.00
1	CompX control to lock five drawers	\$2,833.33	\$2,550.00
3	Fixed dividers in forward portion of cabinet "E"	\$250.00	\$225.00
1	Hinged red painted aluminum to access sharps and waste at head of bench. Photos in file.	\$744.44	\$670.00
1	3-slot vest holder (Left wall)	\$444.44	\$400.00
1	Stainless guard, left rear	\$100.00	\$90.00
1	Plastic guard, left rear	\$100.00	\$90.00
1	Corner trim per drawings	\$194.44	\$175.00
1	Install standard CompX narc box over bench	\$1,300.00	\$1,170.00
Custom Body Size, Compartments, Doors & Door Window			Total
1	EX-01 Custom body Length. Fill in Length 186"	\$777.78	\$700.00
1	EX-03 Additional Exterior Compartment, (Separate OSS #1 Compartment)	\$1,138.89	\$1,025.00
1	EX-04 Compartment Over Wheel Well w/ Rollout Drawer (note: top hinge)	\$1,361.11	\$1,225.00
5	EX-05 Change Exterior Compartment Size	\$1,944.44	\$1,750.00
2	EX-09 Double Door on Exterior Compartment ILO Single Door	\$1,055.56	\$950.00
1	EX-16 Dry Deck All Compartments	\$677.78	\$610.00
Shelves & Dividers			
1	EX-19 Adjustable Shelving Unit in Exterior Compartment w/One Shelf 12"-30" wide #5	\$216.67	\$195.00
1	EX-20 Adjustable Shelving Unit in Exterior Compartment w/One Shelf 30"-48" wide #4	\$227.78	\$205.00
1	EX-22 Additional Shelf in Exterior Compartment 12"-30" wide #5	\$133.33	\$120.00
1	EX-23 Additional Shelf in Exterior Compartment 30"-48" wide #2	\$144.44	\$130.00
2	EX-24 Aluminum Backboard Divider	\$433.33	\$390.00
1	EX-27 Additional Backboard Strap match previous	\$50.00	\$45.00
Rear Bumpers & Entry Steps			
1	EX-34 Smooth Aluminum Kickplates (3)		nc
3	EX-35 Dual Interior Emergency Door-Open Handles, Price per Door	\$316.67	\$285.00
2	EX-38 Drop Skirt Line 6" from Right Rear Wheel to Right Front Corner, Add 2nd Entry Step (Drop Skirt = Both Sides)	\$1,500.00	\$1,350.00
1	Additional Charge for Extra Body Length	\$777.78	\$700.00
1	Recess for air eject	\$416.67	\$375.00
1	Fixed shelf 12" from top of OSS #5 with screwed on removable panel	\$333.33	\$300.00
2	Gas struts on #3 compartment door	\$166.67	\$150.00
1	OSS #1 shall have (2) separate compartments and doors. - Lockable upper #1A shall have single door and will house 110 components & inverter. Door shall be lockable manually (no power lock). Vent to exterior only Lower compartment #1B to be connected to power locks. (EX-03) Storage for four (3) SCBA bottles at bottom floor of OSS #1. Removeable pocket for 25" depth.	\$1,000.00	\$900.00
1	NOTE: Scorpion inside of above tubes	\$1,000.00	\$900.00
3		\$550.00	\$495.00
2	Two (3) Angled brackets for above	\$222.22	\$200.00
1	Aluminum backboard strap, #7	\$111.11	\$100.00
3	12" X 12" placard / brackets. Match J2752	\$666.67	\$600.00
1	Chrome center caps	\$444.44	\$400.00
1	Fixed Shelf in #7	\$200.00	\$180.00
1	.125" flat aluminum peg board covering B wall of #4. .023" holes spaced 1.875" apart	\$1,083.33	\$975.00
Rub Rail, Tow Hooks, Mud Flaps, Chains			
1	EX-45 Reflective Tape in Rub Rail--FILL IN COLOR White	\$388.89	\$350.00
1	EX-47 Stainless Steel Fuel Guard	\$72.22	\$65.00
1	EX-49 Taller Front Stone Guards	\$122.22	\$110.00
1	EX-61 Rubber Fenderettes		nc
1	EX-66 Divider & Fixed Shelf in #1	(\$250.00)	(\$225.00)
MISCELLANEOUS OPTIONS			
1	MS-01 Credit for Shipping Spare Tire Loose	(\$55.56)	(\$50.00)
1	MS-05 Delete Decal Package	(\$138.89)	(\$125.00)
1	MS-06 Extended Electrical Warranty 7-years/100,000	\$777.78	\$700.00
Additional Exterior & Miscellaneous Options & Special Instructions			
1	Square Compartment for four (4) D Tanks aft of rear wheel. Note: Use real door.	\$1,333.33	\$1,200.00
1	NOTE: Scorpion inside of above tubes	\$950.00	\$855.00
1	5" Drop floor of OSS #4	\$333.33	\$300.00
1	OSS #4 shall be roll up door with shield	\$888.89	\$800.00
1	Amdor 9355-36 strap for roll up door	\$77.78	\$70.00
2	Cast Lo-Pro Vent on #1 and #1A Doors	\$166.67	\$150.00
2	Nader Pin Covers on lower rear nader pins	\$111.11	\$100.00
1	NOTE: Drip Rails shall be adhered with VHB. No Screws will be used.		
PAINT OPTIONS			
1	P-08 1/2 Red / 1/2 BLACK Cab & Box (Including Door Jambs) Black FLNA 40119	\$6,027.78	\$5,425.00
1	P-09 Red Paint Color, (Additional Materials Cost) FLNA 30484	\$666.67	\$600.00
1	P-11 Wet Sand & Buff	\$3,466.67	\$3,120.00
1	P-14 Delete Standard Beltline Paint	(\$555.56)	(\$500.00)
Pinstripe			
1	P-23 6' Oracal Reflexite Chevron, Two Colors	\$1,666.67	\$1,500.00
1	P-29 6" Oracal Reflexite Chevron on Rear Doors, Two Colors	\$1,000.00	\$900.00
Additional Paint Options & Special Instructions			
1	Broward County Graphics	\$4,722.22	\$4,250.00
1	Top of module shall be painted white and not visible from ground	\$888.89	\$800.00
1	Chevron kick plate below rear doors. Match J2541.	\$500.00	\$450.00
1	Install 12" number and 32" SOL on roof	\$133.33	\$120.00
Additional Options			
1	Dealer Provided / Osage Installed Firecom System (6) Station System w/headsets	\$2,947.78	\$2,653.00
1	Stryker Power Pro Cot (per BSO Spec)	\$23,971.11	\$21,574.00
1	Stryker Power Stair Pro Stair Chair (per BSO Spec)	\$4,363.33	\$3,927.00
ORDER SUMMARY			
1	SUBTOTAL OF OPTIONS: \$	\$188,037.78	\$169,234.00

<u>1</u>	(+) BASE PRICE: \$	<u>\$272,832.22</u>	<u>\$245,549.00</u>
<u>1</u>	TOTAL UNIT PRICE: \$	\$460,870.00	\$414,783.00

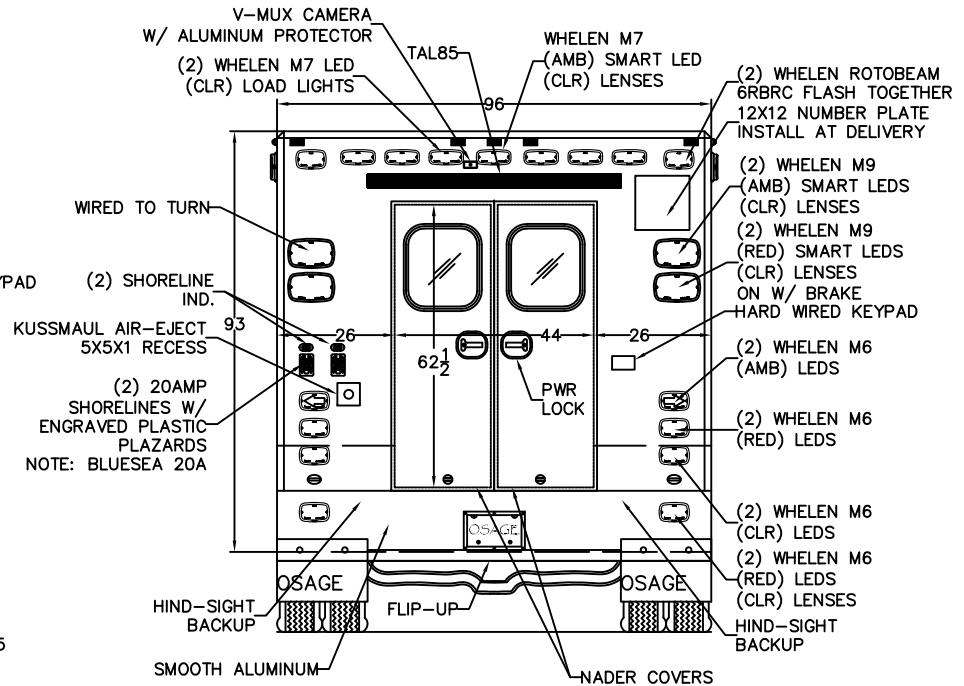
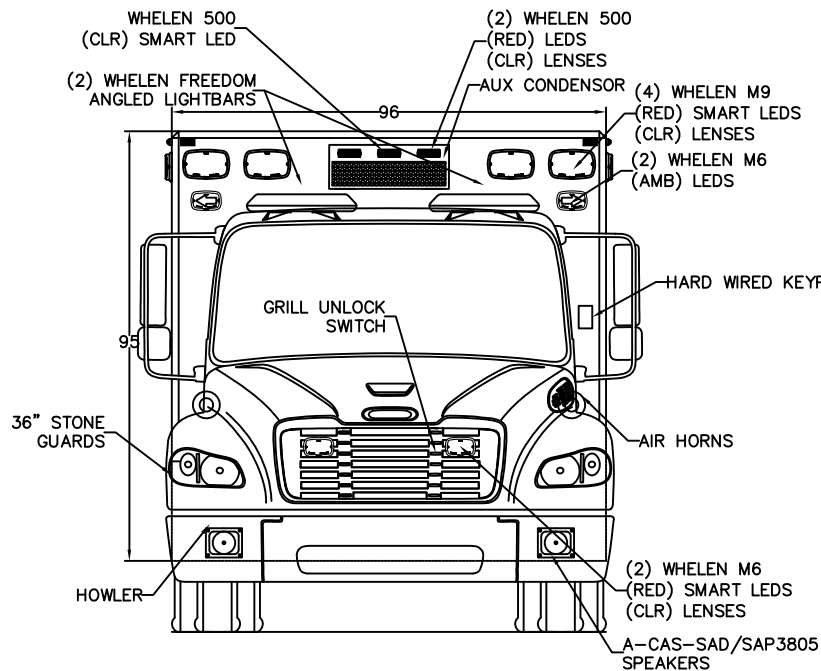

NOTES: THIS DRAWING IS NOT TO SCALE. CHARACTERISTICS AND DIMENSIONS OF FINISHED PRODUCT MAY VARY.

NOTES:

- 1.) COMPARTMENT DIMENSIONS REFLECT OPENING CLEARANCE.
- 2.) APPROXIMATE COMPARTMENT DEPTH=21"DEEP.
- 3.) MODULE DIMENSIONS=186"L x 96"W x 95"H.
- 4.) INTERIOR MODULE HEAD ROOM=74"H.
- 5.) FREIGHTLINER M2 175" WHEEL BASE CHASSIS.
- 6.) ALL 9x7 LIGHTS TO BE WHELEN M9 SERIES LIGHTS, CHROME FLANGES.
- 7.) DOUBLE STAINLESS THRESHOLDS.
- 8.) 3M SOUND DEADENING.
- 9.) SMOOTH ALUMINUM DOOR PANELS.
- 10.) AMBER WHELEN OS LIGHTS ON INTERIOR OF REAR-FACING DOORS.
- 11.) DRY-DECK, ALL COMPARTMENTS.
- 12.) TECHNIQUE LED STRIP-LIGHTS IN ALL COMPARTMENTS.
- 13.) COT MOUNT TO BE CENTERED 16" OFF OF LEFT WALL.

Stock/Job#:	J3005-J3007	Drawing#	J3005-100A	Cust. App'v/Date#	Deal'r App'v/Date:
Osage Dealer:	TEN-8 FIRE	<p style="text-align: center;">Osage Industries, Inc.</p> <p style="text-align: center;">TWIN RIDGE ROAD P.O. BOX 718 LINN, MO. 65051</p>			
End Customer:	BROWARD COUNTY				
NOTICE		Drawn By:	S.A.H.	Date:	12-17-20
Revision#		Drawing Description:			Scale:
3		EXTERIOR LAYOUT, FRONT/REAR TYPE-I FREIGHTLINER (SUPER-WARRIOR)			NOT TO SCALE
2		Revision#			1
1					
Rev.#	Revision Description	Date	Rev'd	App'vd	

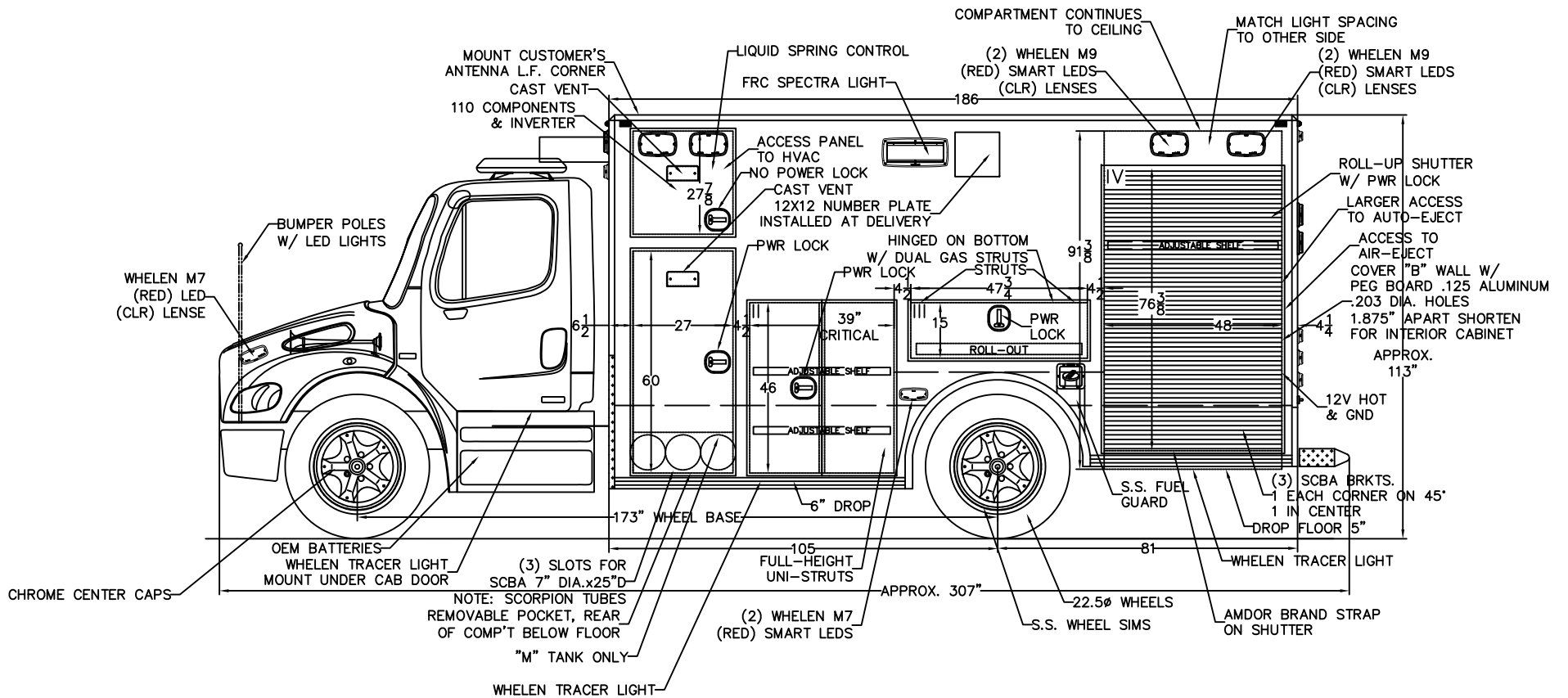

NOTES: THIS DRAWING IS NOT TO SCALE.
CHARACTERISTICS AND DIMENSIONS OF FINISHED PRODUCT MAY VARY.

NOTES:

- 1.) COMPARTMENT DIMENSIONS REFLECT OPENING CLEARANCE.
- 2.) APPROXIMATE COMPARTMENT DEPTH=21"DEEP.
- 3.) MODULE DIMENSIONS=186"L x 96"W x 95"H.
- 4.) INTERIOR MODULE HEAD ROOM=74"H.
- 5.) FREIGHTLINER M2 175" WHEEL BASE CHASSIS.
- 6.) ALL 9x7 LIGHTS TO BE WHELEN M9 SERIES LIGHTS, CHROME FLANGES.
- 7.) DOUBLE STAINLESS THRESHOLDS.
- 8.) 3M SOUND DEADENING.
- 9.) SMOOTH ALUMINUM DOOR PANELS.
- 10.) AMBER WHELEN OS LIGHTS ON INTERIOR OF REAR-FACING DOORS.
- 11.) DRY-DECK, ALL COMPARTMENTS.
- 12.) TECHNIQUE LED STRIP-LIGHTS IN ALL COMPARTMENTS.
- 13.) COT MOUNT TO BE CENTERED 16" OFF OF LEFT WALL.

Stock/Job#:	J3005-J3007	Drawing#	J3005-100B	Cust. App'v/Date#	Deal'r App'v/Date:
Osage Dealer:	TEN-8 FIRE	<h1 style="margin: 0;">Osage Industries, Inc.</h1> <p style="margin: 0;">TWIN RIDGE ROAD P.O. BOX 718 LINN, MO. 65051</p>			
End Customer:	BROWARD COUNTY				
NOTICE		Drawn By:	S.A.H.	Date:	12-17-20
This drawing and/or the information hereon is the exclusive property of Osage Industries and shall not be reproduced, used or disclosed without the authorized written consent of Osage Industries.		Drawing Description:			Revision#
		EXTERIOR LAYOUT, STREETSIDE TYPE-I FREIGHTLINER (SUPER-WARRIOR)			1
3					
2					
1	PRODUCTION DRAFT	12-17-20	SAH		
Rev.#	Revision Description	Date	Rev'd	App'vd	

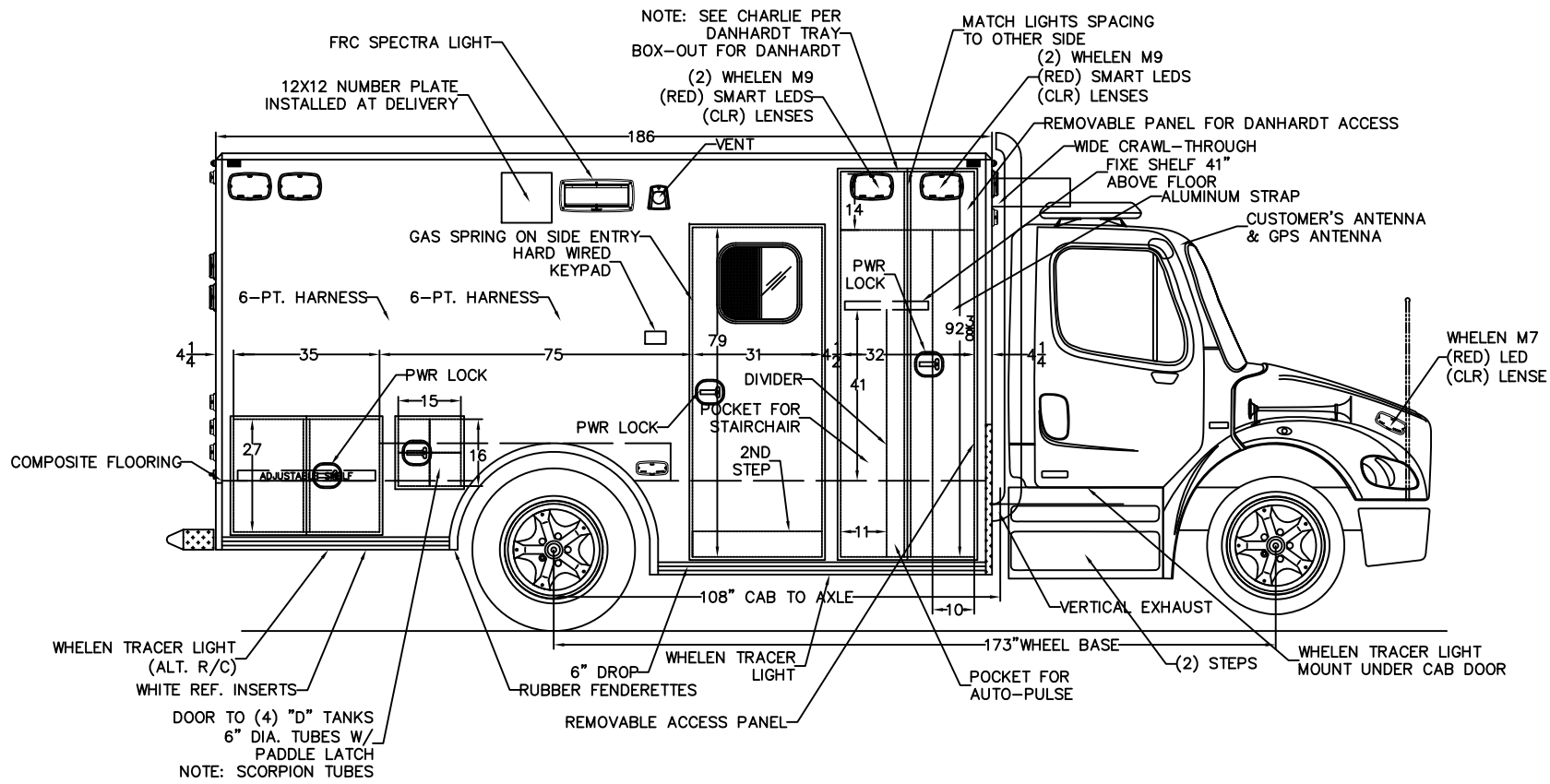

NOTES: THIS DRAWING IS NOT TO SCALE.
CHARACTERISTICS AND DIMENSIONS OF FINISHED PRODUCT MAY VARY.

- NOTES:
- 1.) COMPARTMENT DIMENSIONS REFLECT OPENING CLEARANCE.
 - 2.) APPROXIMATE COMPARTMENT DEPTH=21"DEEP.
 - 3.) MODULE DIMENSIONS=186"L x 96"W x 95"H.
 - 4.) INTERIOR MODULE HEAD ROOM=74"H.
 - 5.) FREIGHTLINER M2 175" WHEEL BASE CHASSIS.
 - 6.) ALL 9x7 LIGHTS TO BE WHELEN M9 SERIES LIGHTS, CHROME FLANGES.
 - 7.) DOUBLE STAINLESS THRESHOLDS.
 - 8.) 3M SOUND DEADENING.
 - 9.) SMOOTH ALUMINUM DOOR PANELS.
 - 10.) AMBER WHELEN OS LIGHTS ON INTERIOR OF REAR-FACING DOORS.
 - 11.) DRY-DECK, ALL COMPARTMENTS.
 - 12.) TECHNIQUE LED STRIP-LIGHTS IN ALL COMPARTMENTS.
 - 13.) COT MOUNT TO BE CENTERED 16" OFF OF LEFT WALL.

Stock/Job#:	J3005-J3007	Drawing#	J3005-100C	Cust. App'v/Date#	Deal'r App'v/Date:
Osage Dealer:	TEN-8 FIRE	<h1 style="margin: 0;">Osage Industries, Inc.</h1> <p style="margin: 0;">TWIN RIDGE ROAD P.O. BOX 718 LINN, MO. 65051</p>			
End Customer:	BROWARD COUNTY				
NOTICE		Drawn By:	S.A.H.	Date:	12-17-20
		Drawing Description:			Scale:
		EXTERIOR LAYOUT, CURBSIDE TYPE-I FREIGHTLINER (SUPER-WARRIOR)			NOT TO SCALE
					Revision#
					1

3				
2				
1	PRODUCTION DRAFT	12-17-20	SAH	.
Rev.#	Revision Description	Date	Rev'd	App'vd

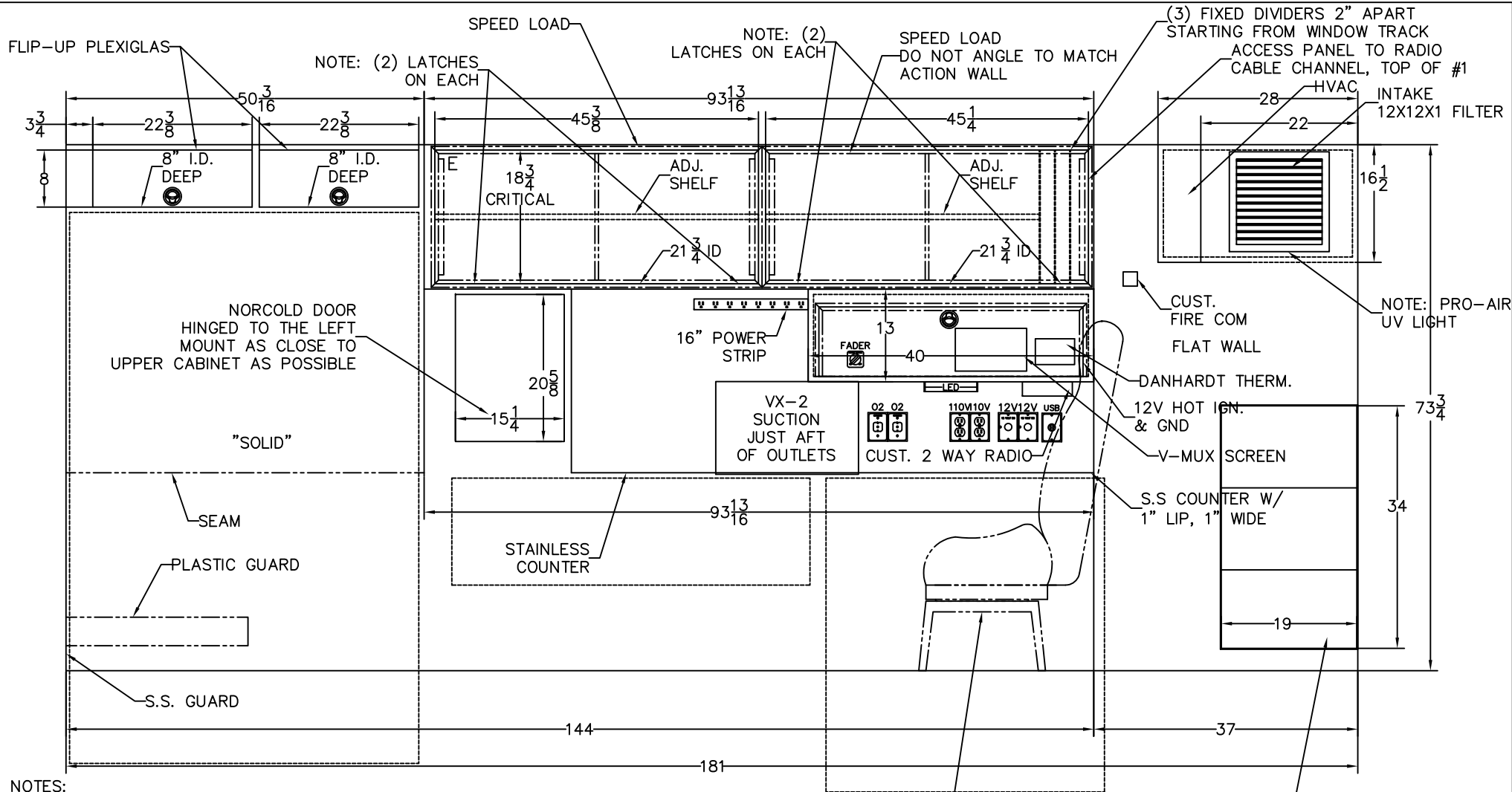

- NOTES:
- 1.) 186" BODY, 74" HEADROOM.
 - 2.) ALUMINUM CABINETS, ZOLATONE 20-62 MARBLESTONE.
 - 3.) RUBBER MATS IN ALL CABINETS & SHELVES.
 - 4.) S.S. SOUTHCOS.

NOTES: THIS DRAWING IS NOT TO SCALE. CHARACTERISTICS AND DIMENSIONS OF FINISHED PRODUCT MAY VARY.

NOTES: CABINET DEPTHS REPRESENT DIMENSION FROM INSIDE REAR TO FRONT FACE OF CABINETS, WITHOUT TRIM. ACTUAL WORKING DEPTH WILL BE LESS THAN DIMENSION SHOWN UNLESS OTHERWISE SPECIFIED.

E.V.S. 5-PT. CHILD/ATTENDANT SEAT W/ SWIVEL, (MOUNT AT DELIVERY)

ALUMINUM VEST HOLDER (MOUNT AT DELIVERY) ALL THE WAY FORWARD

Stock/Job#:	J3005-J3007	Drawing#	J3005-101	Cust. App'v/Date#	Deal'r App'v/Date:
-------------	-------------	----------	-----------	-------------------	--------------------

Osage Dealer:	TEN-8 FIRE	<h1 style="margin: 0;">Osage Industries, Inc.</h1>	
End Customer:	BROWARD COUNTY		

NOTICE		Drawn By:	S.A.H	Date:	12-17-20	Scale:	NOT TO SCALE
--------	--	-----------	-------	-------	----------	--------	--------------

This drawing and/or the information hereon is the exclusive property of Osage Industries and shall not be reproduced, used or disclosed without the authorized written consent of Osage Industries.		Drawing Description:			Revision#
		STREETSIDE INTERIOR, TYPE-I FREIGHTLINER (SUPER-WARRIOR)			1

3				
2				
1	PRODUCTION DRAFT	12-17-20	SAH	
Rev.#	Revision Description	Date	Rev'd	App'vd

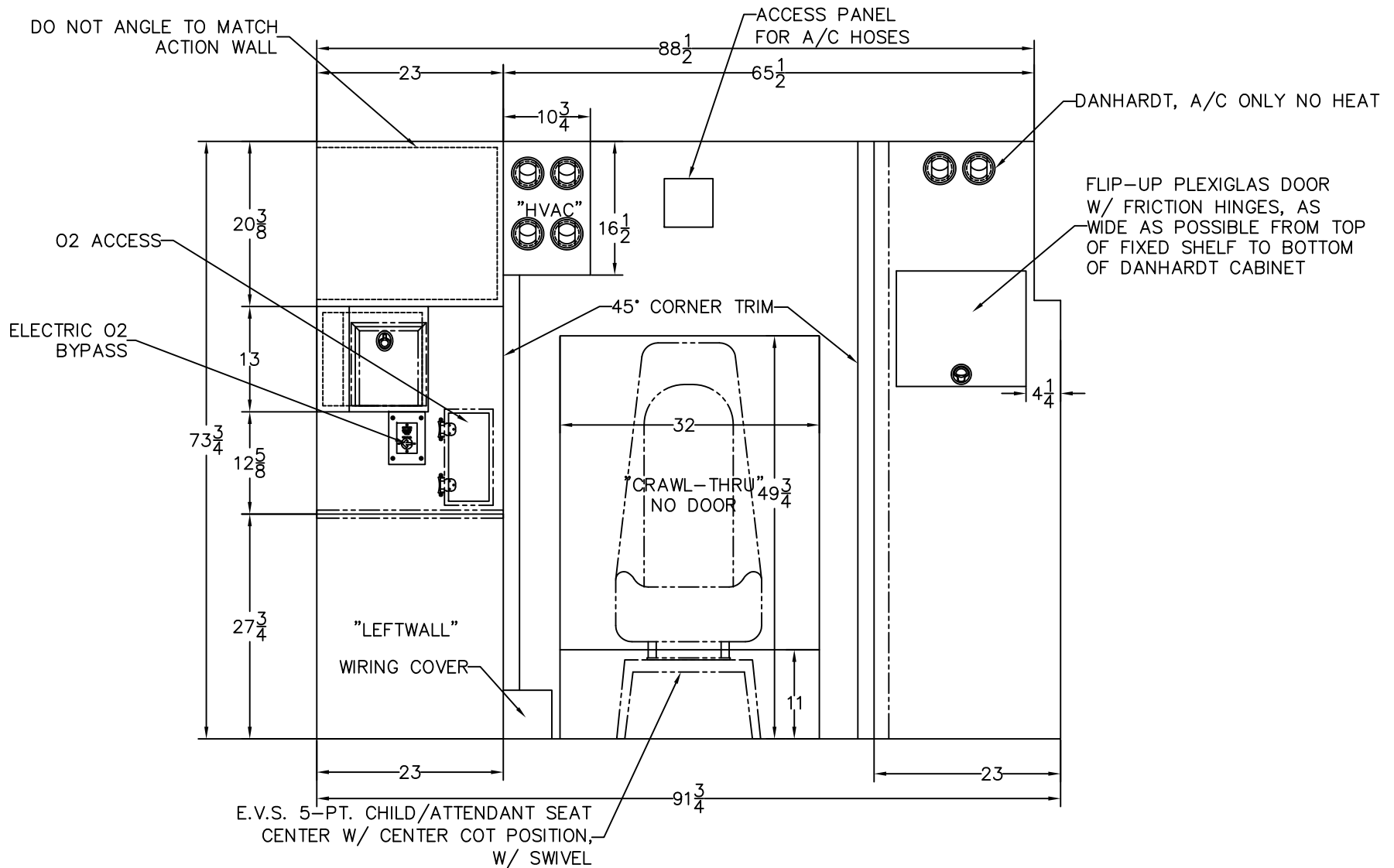

NOTES: THIS DRAWING IS NOT TO SCALE.
CHARACTERISTICS AND DIMENSIONS OF FINISHED PRODUCT MAY VARY.

NOTES: CABINET DEPTHS REPRESENT DIMENSION FROM INSIDE REAR TO FRONT FACE OF CABINETS, WITHOUT TRIM.
ACTUAL WORKING DEPTH WILL BE LESS THAN DIMENSION SHOWN UNLESS OTHERWISE SPECIFIED.

Stock/Job#	J3005-J3007	Drawing#	J3005-102	Cust. App'v/Date#	Deal'r App'v/Date:
Osage Dealer:	TEN-8 FIRE	Osage Industries, Inc. TWIN RIDGE ROAD P.O. BOX 718 LINN, MO. 65051			
End Customer:	BROWARD COUNTY				
NOTICE		Drawn By:	S.A.H.	Date:	12-17-20
This drawing and/or the information hereon is the exclusive property of Osage Industries and shall not be reproduced, used or disclosed without the authorized written consent of Osage Industries.		Drawing Description:			Scale:
		FORWARD INTERIOR, TYPE-I FREIGHTLINER (SUPER-WARRIOR)			NOT TO SCALE
Rev.#	Revision Description	Date	Rev'd	App'vd	Revision#
3					
2					
1	PRODUCTION DRAFT	12-17-20	SAH		1

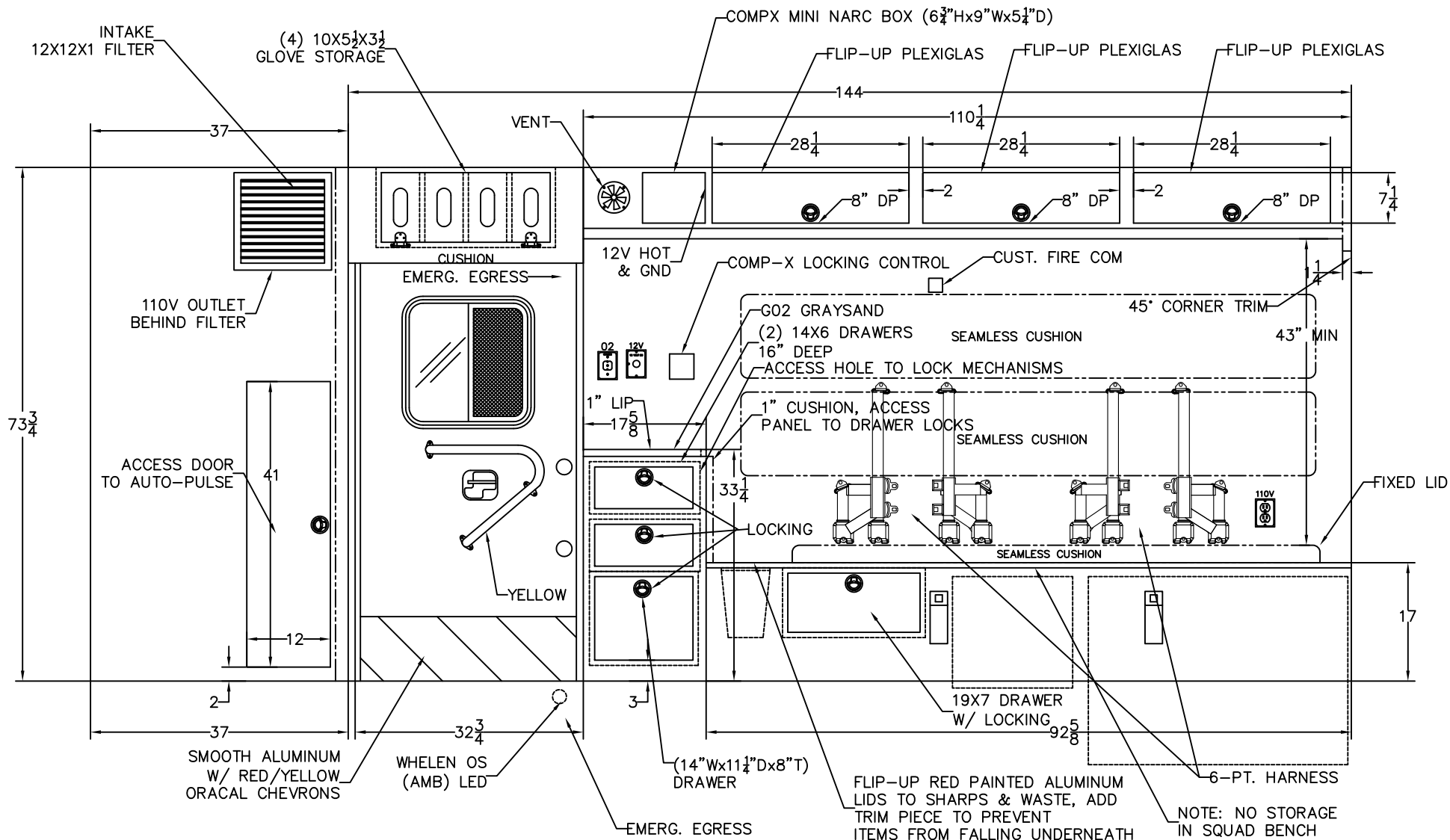

NOTES: THIS DRAWING IS NOT TO SCALE. CHARACTERISTICS AND DIMENSIONS OF FINISHED PRODUCT MAY VARY.

NOTES: CABINET DEPTHS REPRESENT DIMENSION FROM INSIDE REAR TO FRONT FACE OF CABINETS, WITHOUT TRIM. ACTUAL WORKING DEPTH WILL BE LESS THAN DIMENSION SHOWN UNLESS OTHERWISE SPECIFIED.

Stock/Job#:	J3005-J3007	Drawing#	J3005-103	Cust. App'v/Date#	Deal'r App'v/Date:
Osage Dealer:	TEN-8 FIRE	<h1 style="margin: 0;">Osage Industries, Inc.</h1> <p style="margin: 0;">TWIN RIDGE ROAD P.O. BOX 718 LINN, MO. 65051</p>			
End Customer:	BROWARD COUNTY				
NOTICE		Drawn By:	S.A.H.	Date:	12-17-20
This drawing and/or the information hereon is the exclusive property of Osage Industries and shall not be reproduced, used or disclosed without the authorized written consent of Osage Industries.		Drawing Description:			Scale:
		CURBSIDE INTERIOR, TYPE-I FREIGHTLINER (SUPER-WARRIOR)			NOT TO SCALE
Rev.#	Revision Description	Date	Rev'd	App'vd	Revision#

3					
2	REVISION DRAFT	03-17-21	SAH		
1	PRODUCTION DRAFT	12-17-20	SAH		
Rev.#	Revision Description	Date	Rev'd	App'vd	

1

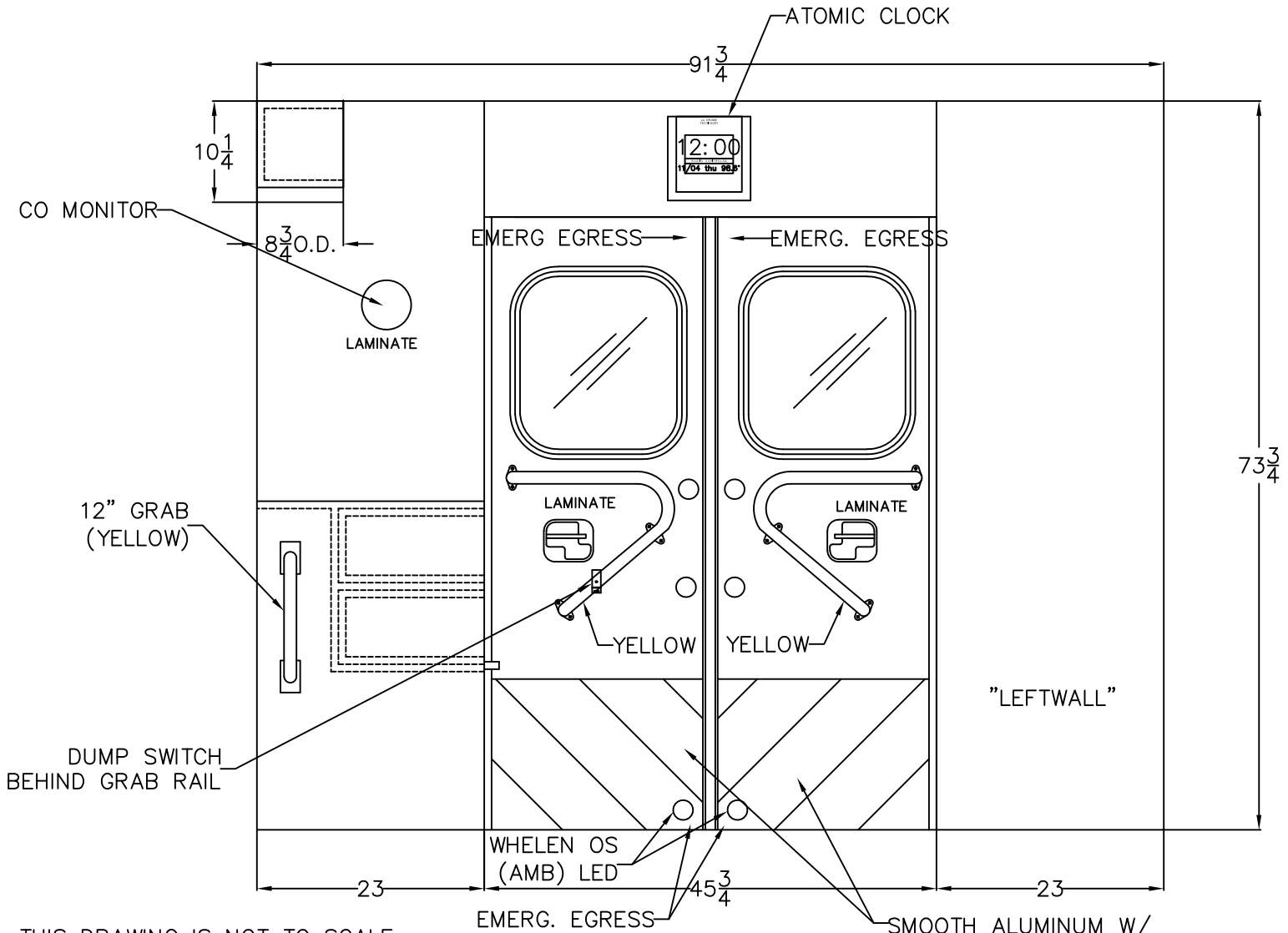

NOTES: THIS DRAWING IS NOT TO SCALE. CHARACTERISTICS AND DIMENSIONS OF FINISHED PRODUCT MAY VARY.

NOTES: CABINET DEPTHS REPRESENT DIMENSION FROM INSIDE REAR TO FRONT FACE OF CABINETS, WITHOUT TRIM. ACTUAL WORKING DEPTH WILL BE LESS THAN DIMENSION SHOWN UNLESS OTHERWISE SPECIFIED.

Stock/Job#:	J3005-J3007	Drawing#	J3005-104	Cust. App'v/Date#		Deal'r App'v/Date:	
Osage Dealer:	TEN-8 FIRE	<h1 style="margin: 0;">Osage Industries, Inc.</h1>		TWIN RIDGE ROAD		P.O. BOX 718	
End Customer:	BROWARD COUNTY			LINN, MO. 65051			
NOTICE		Drawn By:	S.A.H.	Date:	12-17-20	Scale:	NOT TO SCALE
		Drawing Description:				Revision#	
		REARWARD INTERIOR, TYPE-I FREIGHTLINER (SUPER-WARRIOR)				1	
Rev.#	Revision Description	Date	Rev'd	App'vd	This drawing and/or the information hereon is the exclusive property of Osage Industries and shall not be reproduced, used or disclosed without the authorized written consent of Osage Industries.		

3				
2				
1	PRODUCTION DRAFT	12-17-20	SAH	
Rev.#	Revision Description	Date	Rev'd	App'vd

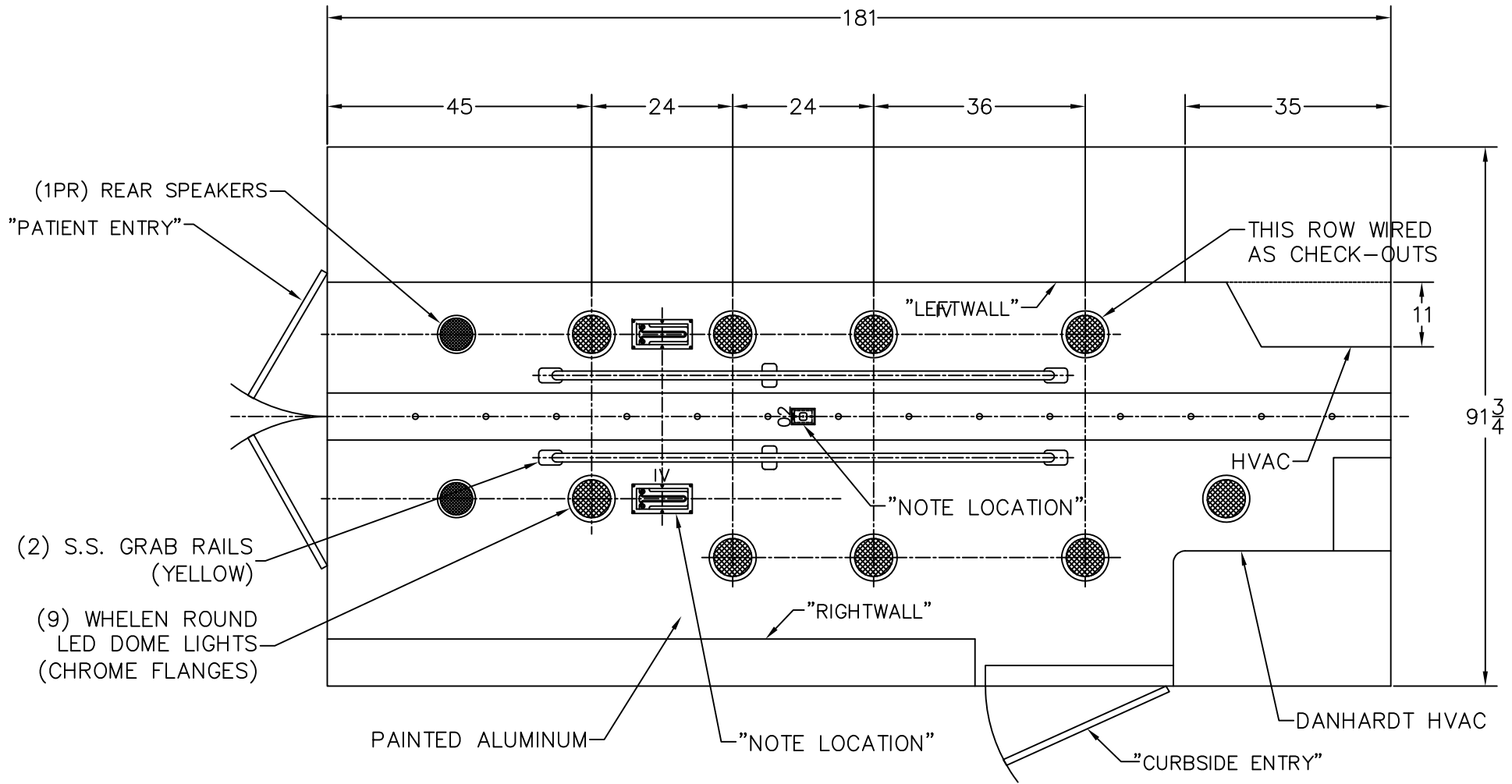

NOTES: THIS DRAWING IS NOT TO SCALE.
 CHARACTERISTICS AND DIMENSIONS OF FINISHED
 PRODUCT MAY VARY.

Stock/Job#:	J3005-J3007	Drawing#	J3005-105	Cust. App'v/Date#	Deal'r App'v/Date:
-------------	-------------	----------	-----------	-------------------	--------------------

Osage Dealer:	TEN-8 FIRE	Osage Industries, Inc. TWIN RIDGE ROAD P.O. BOX 718 LINN, MO. 65051			
End Customer:	BROWARD COUNTY				

NOTICE		Drawn By:	S.A.H.	Date:	12-17-20	Scale:	NOT TO SCALE
---------------	--	-----------	--------	-------	----------	--------	--------------

This drawing and/or the information hereon is the exclusive property of Osage Industries and shall not be reproduced, used or disclosed without the authorized written consent of Osage Industries.		Drawn By:	S.A.H.	Date:	12-17-20	Scale:	NOT TO SCALE
		Drawing Description: CEILING LAYOUT, TYPE-I FREIGHTLINER (SUPER-WARRIOR)					

Rev.#	Revision Description	Date	Rev'd	App'vd
3				
2				
1	PRODUCTION DRAFT	12-17-20	SAH	

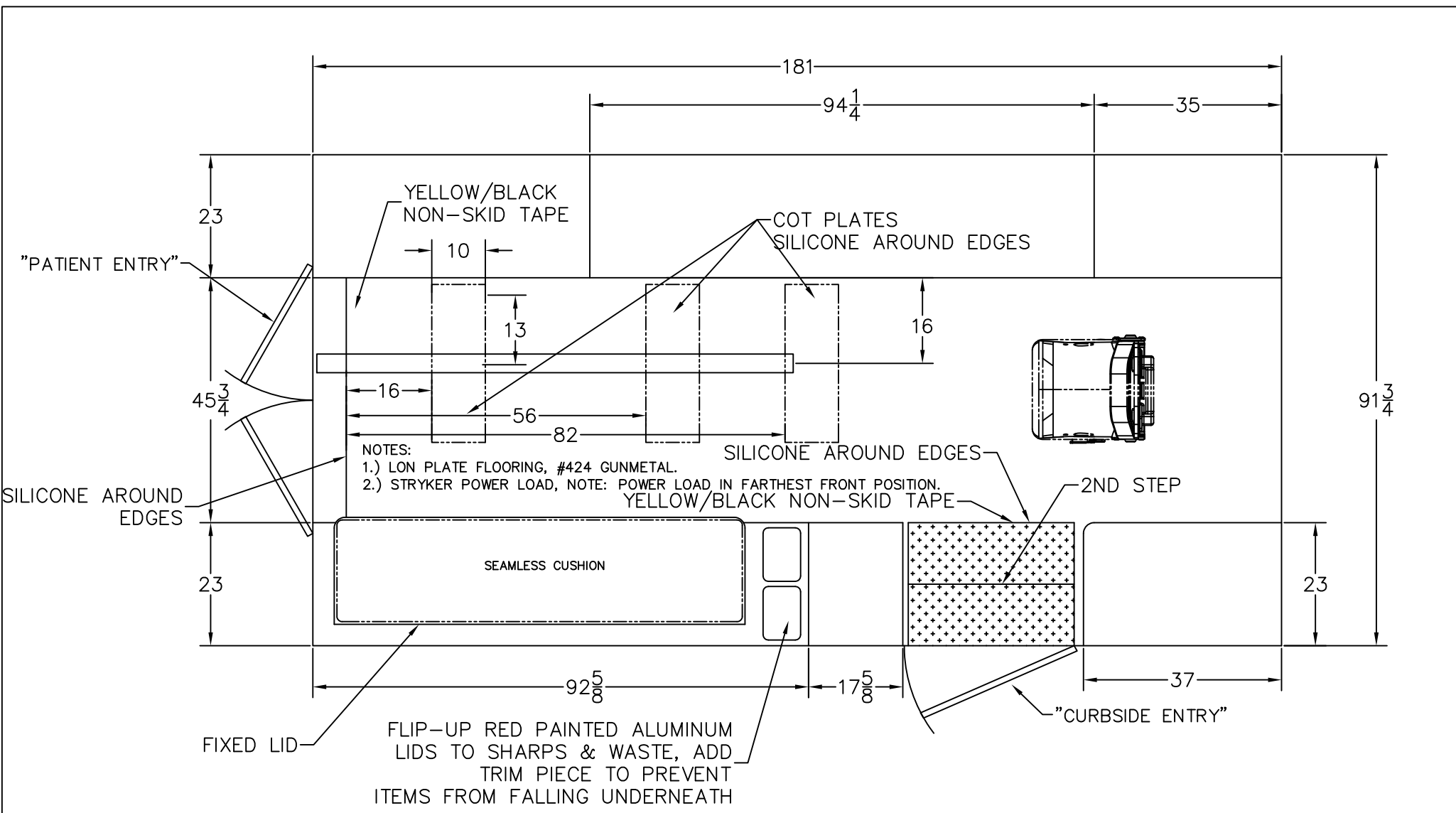

NOTES:

- 1.) LON PLATE FLOORING, #424 GUNMETAL.
- 2.) STRYKER POWER LOAD, NOTE: POWER LOAD IN FARTHEST FRONT POSITION.

NOTES: THIS DRAWING IS NOT TO SCALE. CHARACTERISTICS AND DIMENSIONS OF FINISHED PRODUCT MAY VARY.

Stock/Job#:	J3005-J3007	Drawing#	J3005-106	Cust. App'v/Date#	Deal'r App'v/Date:
-------------	-------------	----------	-----------	-------------------	--------------------

Osage Dealer:	TEN-8 FIRE	<h1>Osage Industries, Inc.</h1>	
End Customer:	BROWARD COUNTY		

TWIN RIDGE ROAD	P.O. BOX 718	LINN, MO. 65051
Drawn By:	S.A.H.	Date: 12-17-20
Scale:		NOT TO SCALE

<p>This drawing and/or the information hereon is the exclusive property of Osage Industries and shall not be reproduced, used or disclosed without the authorized written consent of Osage Industries.</p>	Drawing Description:		Revision#
	FLOOR LAYOUT, TYPE-I FREIGHTLINER (SUPER-WARRIOR)		1

Rev.#	Revision Description	Date	Rev'd	App'vd
3				
2				
1	PRODUCTION DRAFT	12-17-20	SAH	

Prepared for:
Paul Marshall
OSAGE AMBULANCE INC
194 TWIN RIDGE RD

LINN, MO 65051
Phone: 314-566-4991

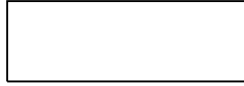

Prepared by:
Rick Kinney
TRUCK CTY OF WISCONSIN,
INC.
2401 PROGRESS WAY
KAUKAUNA, WI 541309559
Phone: 920-766-5222

A proposal for
OSAGE AMBULANCE INC

Prepared by
TRUCK CTY OF WISCONSIN, INC.
Rick Kinney

MY2023 BSO
BUDGETARY ONLY

Oct 05, 2021

Freightliner M2 106



Components shown may not reflect all spec'd options and are not to scale

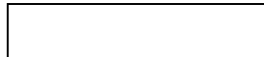

Prepared for:
Paul Marshall
OSAGE AMBULANCE INC
194 TWIN RIDGE RD



LINN, MO 65051
Phone: 314-566-4991

Prepared by:
Rick Kinney
TRUCK CTY OF WISCONSIN,
INC.
2401 PROGRESS WAY
KAUKAUNA, WI 541309559
Phone: 920-766-5222

S P E C I F I C A T I O N P R O P O S A L

Data Code	Description	Weight Front	Weight Rear
Price Level			
PRL-26M	M2 PRL-26M (EFF:7/26/21)		
Data Version			
DRL-018	SPECPRO21 DATA RELEASE VER 018		
Interior Convenience/Driver Retention Package			
055-002	INTERIOR CONVENIENCE PACKAGE		
Vehicle Configuration			
001-172	M2 106 CONVENTIONAL CHASSIS	5,709	3,503
004-223	2023 MODEL YEAR SPECIFIED		
002-004	SET BACK AXLE - TRUCK		
019-002	STRAIGHT TRUCK PROVISION		
003-001	LH PRIMARY STEERING LOCATION		
General Service			
AA1-002	TRUCK CONFIGURATION		
AA6-002	DOMICILED, USA (EXCLUDING CALIFORNIA AND CARB OPT-IN STATES)		
A85-006	RESCUE AND EMERGENCY SERVICE		
A84-1EV	EMERGENCY VEHICLES BUSINESS SEGMENT		
AA4-011	FIXED LOAD COMMODITY		
AA5-002	TERRAIN/DUTY: 100% (ALL) OF THE TIME, IN TRANSIT, IS SPENT ON PAVED ROADS		
AB1-008	MAXIMUM 8% EXPECTED GRADE		
AB5-001	SMOOTH CONCRETE OR ASPHALT PAVEMENT - MOST SEVERE IN-TRANSIT (BETWEEN SITES) ROAD SURFACE		
995-091	MEDIUM TRUCK WARRANTY		
A66-99D	EXPECTED FRONT AXLE(S) LOAD : 10000.0 lbs		
A68-99D	EXPECTED REAR DRIVE AXLE(S) LOAD : 12000.0 lbs		
A63-99D	EXPECTED GROSS VEHICLE WEIGHT CAPACITY : 22000.0 lbs		

Application Version 11.6.505
Data Version PRL-26M.018
2023 Broward Sheriffs Office

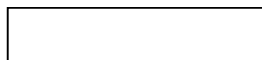

10/05/2021 11:47 AM

Prepared for:
 Paul Marshall
 OSAGE AMBULANCE INC
 194 TWIN RIDGE RD



LINN, MO 65051
 Phone: 314-566-4991

Prepared by:
 Rick Kinney
 TRUCK CTY OF WISCONSIN,
 INC.
 2401 PROGRESS WAY
 KAUKAUNA, WI 541309559
 Phone: 920-766-5222

Data Code	Description	Weight Front	Weight Rear
Truck Service			
AA3-024	AMBULANCE BODY		
A88-99D	EXPECTED TRUCK BODY LENGTH : 16.0 ft		
AF3-999	CUSTOM MFR'S/BODY TYPE IDENTIFICATION		
AF7-99D	EXPECTED BODY/PAYLOAD CG HEIGHT ABOVE FRAME "XX" INCHES : 32.0 in		
Engine			
101-22A	CUM B6.7 260EV HP @ 2400 RPM, 2600 GOV, 660 LB-FT @ 1600 RPM, R/F/E		
Electronic Parameters			
79A-075	75 MPH ROAD SPEED LIMIT		
79B-000	CRUISE CONTROL SPEED LIMIT SAME AS ROAD SPEED LIMIT		
79K-007	PTO MODE ENGINE RPM LIMIT - 1100 RPM		
79P-002	PTO RPM WITH CRUISE SET SWITCH - 700 RPM		
79Q-003	PTO RPM WITH CRUISE RESUME SWITCH - 800 RPM		
79S-001	PTO MODE CANCEL VEHICLE SPEED - 5 MPH		
79U-007	PTO GOVERNOR RAMP RATE - 250 RPM PER SECOND		
80G-002	PTO MINIMUM RPM - 700		
80J-001	REGEN INHIBIT SPEED THRESHOLD - 0 MPH		
Engine Equipment			
99C-021	2016 ONBOARD DIAGNOSTICS/2010 EPA/CARB/GHG21 CONFIGURATION		
99D-010	NO 2008 CARB EMISSION CERTIFICATION		
13E-001	STANDARD OIL PAN		
105-001	ENGINE MOUNTED OIL CHECK AND FILL		
014-099	SIDE OF HOOD AIR INTAKE WITH FIREWALL MOUNTED DONALDSON AIR CLEANER		
124-120	LN 12V 320 AMP 4962PGH PAD MOUNT ALTERNATOR	10	
292-203	(3) DTNA GENUINE, FLOODED STARTING, MIN 2250CCA, 510RC, THREADED STUD BATTERIES	40	20
290-017	BATTERY BOX FRAME MOUNTED		
281-001	STANDARD BATTERY JUMPERS		
282-042	LH BATTERY BOX MOUNTED AS FAR AFT AS POSSIBLE, NO GREATER THAN 60 INCHES BACK OF CAB		

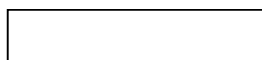

Prepared for:
 Paul Marshall
 OSAGE AMBULANCE INC
 194 TWIN RIDGE RD



LINN, MO 65051
 Phone: 314-566-4991

Prepared by:
 Rick Kinney
 TRUCK CTY OF WISCONSIN,
 INC.
 2401 PROGRESS WAY
 KAUKAUNA, WI 541309559
 Phone: 920-766-5222

Data Code	Description	Weight Front	Weight Rear
291-017	WIRE GROUND RETURN FOR BATTERY CABLES WITH ADDITIONAL FRAME GROUND RETURN		
289-001	NON-POLISHED BATTERY BOX COVER		
87P-001	CAB AUXILIARY POWER CABLE	5	
295-029	POSITIVE AND NEGATIVE POSTS FOR JUMPSTART LOCATED ON FRAME NEXT TO STARTER	2	
107-032	CUMMINS TURBOCHARGED 18.7 CFM AIR COMPRESSOR WITH INTERNAL SAFETY VALVE		
108-002	STANDARD MECHANICAL AIR COMPRESSOR GOVERNOR		
131-013	AIR COMPRESSOR DISCHARGE LINE		
152-039	GVG, FIRE AND EMERGENCY SERVICE VEHICLES ENGINE WARNING		
128-1AR	CUMMINS EXHAUST BRAKE INTEGRAL WITH VARIABLE GEOMETRY TURBO WITH ON/OFF DASH SWITCH, ACTIVATES STOP LAMPS		
016-1C2	RH OUTBOARD UNDER STEP MOUNTED HORIZONTAL AFTERTREATMENT SYSTEM ASSEMBLY WITH RH B-PILLAR MOUNTED VERTICAL TAILPIPE	30	25
28F-007	ENGINE AFTERTREATMENT DEVICE, AUTOMATIC OVER THE ROAD ACTIVE REGENERATION AND DASH MOUNTED SINGLE REGENERATION REQUEST/INHIBIT SWITCH		
239-020	10 FOOT 00 INCH (120 INCH+0/-5.9 INCH) EXHAUST SYSTEM HEIGHT		
233-017	STANDARD CURVE BRIGHT UPPER STACK(S)		
237-1CR	RH CURVED VERTICAL TAILPIPE B-PILLAR MOUNTED ROUTED FROM STEP		
23U-001	6 GALLON DIESEL EXHAUST FLUID TANK		
30N-003	100 PERCENT DIESEL EXHAUST FLUID FILL		
43X-999	AMBULANCE DEF CONFIGURATION		
43Y-001	STANDARD DIESEL EXHAUST FLUID TANK CAP		
242-001	STAINLESS STEEL AFTERTREATMENT DEVICE/MUFFLER/TAIPIPE SHIELD		
273-058	AIR POWERED ON/OFF ENGINE FAN CLUTCH		
276-002	AUTOMATIC FAN CONTROL WITH DASH SWITCH AND INDICATOR LIGHT, NON ENGINE MOUNTED		
110-003	CUMMINS SPIN ON FUEL FILTER		
118-001	FULL FLOW OIL FILTER		
266-100	700 SQUARE INCH ALUMINUM RADIATOR		

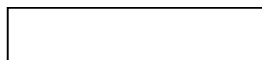

Prepared for:
 Paul Marshall
 OSAGE AMBULANCE INC
 194 TWIN RIDGE RD



LINN, MO 65051
 Phone: 314-566-4991

Prepared by:
 Rick Kinney
 TRUCK CTY OF WISCONSIN,
 INC.
 2401 PROGRESS WAY
 KAUKAUNA, WI 541309559
 Phone: 920-766-5222

Data Code	Description	Weight Front	Weight Rear
103-039	ANTIFREEZE TO -34F, OAT (NITRITE AND SILICATE FREE) EXTENDED LIFE COOLANT		
171-007	GATES BLUE STRIPE COOLANT HOSES OR EQUIVALENT		
172-001	CONSTANT TENSION HOSE CLAMPS FOR COOLANT HOSES		
270-016	RADIATOR DRAIN VALVE		
168-002	LOWER RADIATOR GUARD		
134-001	ALUMINUM FLYWHEEL HOUSING		
132-004	ELECTRIC GRID AIR INTAKE WARMER		
155-058	DELCO 12V 38MT HD STARTER WITH INTEGRATED MAGNETIC SWITCH		

Transmission

342-1KD	ALLISON 3000 EVS AUTOMATIC TRANSMISSION WITH PTO PROVISION	200	60
---------	--	-----	----

Transmission Equipment

343-343	ALLISON VOCATIONAL PACKAGE 227 - AVAILABLE ON 3000/4000 PRODUCT FAMILIES WITH VOCATIONAL MODEL EVS		
84B-003	ALLISON VOCATIONAL RATING FOR FIRE TRUCK/EMERGENCY VEHICLE APPLICATIONS AVAILABLE WITH ALL PRODUCT FAMILIES		
84C-023	PRIMARY MODE GEARS, LOWEST GEAR 1, START GEAR 1, HIGHEST GEAR 6, AVAILABLE FOR 3000/4000 PRODUCT FAMILIES ONLY		
84D-023	SECONDARY MODE GEARS, LOWEST GEAR 1, START GEAR 1, HIGHEST GEAR 6, AVAILABLE FOR 3000/4000 PRODUCT FAMILIES ONLY		
84E-000	PRIMARY SHIFT SCHEDULE RECOMMENDED BY DTNA AND ALLISON, THIS DEFINED BY ENGINE AND VOCATIONAL USAGE		
84F-000	SECONDARY SHIFT SCHEDULE RECOMMENDED BY DTNA AND ALLISON, THIS DEFINED BY ENGINE AND VOCATIONAL USAGE		
84G-000	PRIMARY SHIFT SPEED RECOMMENDED BY DTNA AND ALLISON, THIS DEFINED BY ENGINE AND VOCATIONAL USAGE		
84H-000	SECONDARY SHIFT SPEED RECOMMENDED BY DTNA AND ALLISON, THIS DEFINED BY ENGINE AND VOCATIONAL USAGE		
84J-000	ENGINE BRAKE RANGE PRESELECT RECOMMENDED BY DTNA AND ALLISON, THIS DEFINED BY ENGINE AND VOCATIONAL USAGE		



Prepared for:
 Paul Marshall
 OSAGE AMBULANCE INC
 194 TWIN RIDGE RD



LINN, MO 65051
 Phone: 314-566-4991

Prepared by:
 Rick Kinney
 TRUCK CTY OF WISCONSIN,
 INC.
 2401 PROGRESS WAY
 KAUKAUNA, WI 541309559
 Phone: 920-766-5222

Data Code	Description	Weight Front	Weight Rear
84K-000	ENGINE BRAKE RANGE ALTERNATE PRESELECT RECOMMENDED BY DTNA AND ALLISON, THIS DEFINED BY ENGINE AND VOCATIONAL USAGE		
84N-200	FUEL SENSE 2.0 DISABLED - PERFORMANCE - TABLE BASED		
84U-000	DRIVER SWITCH INPUT - DEFAULT - NO SWITCHES		
353-065	VEHICLE INTERFACE WIRING CONNECTOR WITH BLUNT CUTS, AT BACK OF CAB		
34C-001	ELECTRONIC TRANSMISSION CUSTOMER ACCESS CONNECTOR FIREWALL MOUNTED		
341-018	MAGNETIC PLUGS, ENGINE DRAIN, TRANSMISSION DRAIN, AXLE(S) FILL AND DRAIN		
345-003	PUSH BUTTON ELECTRONIC SHIFT CONTROL, DASH MOUNTED		
97G-004	TRANSMISSION PROGNOSTICS - ENABLED 2013		
370-015	WATER TO OIL TRANSMISSION COOLER, IN RADIATOR END TANK		
346-003	TRANSMISSION OIL CHECK AND FILL WITH ELECTRONIC OIL LEVEL CHECK		
35T-001	SYNTHETIC TRANSMISSION FLUID (TES-295 COMPLIANT)		

Front Axle and Equipment

400-1A5	DETROIT DA-F-10.0-3 10,000# FF1 71.5 KPI/3.74 DROP SINGLE FRONT AXLE		
402-020	MERITOR 15X4 Q+ CAM FRONT BRAKES		
403-026	FIRE AND EMERGENCY SEVERE SERVICE, NON-ASBESTOS FRONT LINING		
419-023	CONMET CAST IRON FRONT BRAKE DRUMS		
427-001	FRONT BRAKE DUST SHIELDS	5	
409-006	FRONT OIL SEALS		
408-001	VENTED FRONT HUB CAPS WITH WINDOW, CENTER AND SIDE PLUGS - OIL		
416-022	STANDARD SPINDLE NUTS FOR ALL AXLES		
405-003	HALDEX AUTOMATIC FRONT SLACK ADJUSTERS		
536-050	TRW THP-60 POWER STEERING		
539-003	POWER STEERING PUMP		
534-015	2 QUART SEE THROUGH POWER STEERING RESERVOIR		
40T-001	MINERAL SAE 80/90 FRONT AXLE LUBE		

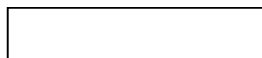

Prepared for:
 Paul Marshall
 OSAGE AMBULANCE INC
 194 TWIN RIDGE RD



LINN, MO 65051
 Phone: 314-566-4991

Prepared by:
 Rick Kinney
 TRUCK CTY OF WISCONSIN,
 INC.
 2401 PROGRESS WAY
 KAUKAUNA, WI 541309559
 Phone: 920-766-5222

Data Code	Description	Weight Front	Weight Rear
Front Suspension			
620-062	10,000# TAPERLEAF FRONT SUSPENSION		
619-005	MAINTENANCE FREE RUBBER BUSHINGS - FRONT SUSPENSION		
629-004	FRONT SWAYBAR	60	
410-001	FRONT SHOCK ABSORBERS		
Rear Axle and Equipment			
420-1C6	DETROIT DA-RS-17.5-2 17,500# R-SERIES SINGLE REAR AXLE		-170
421-478	4.78 REAR AXLE RATIO		
424-001	IRON REAR AXLE CARRIER WITH STANDARD AXLE HOUSING		
386-079	MXL 16T MERITOR EXTENDED LUBE MAIN DRIVELINE WITH HALF ROUND YOKES	-20	-20
423-020	MERITOR 16.5X7 Q+ CAST SPIDER CAM REAR BRAKES, DOUBLE ANCHOR, FABRICATED SHOES		
433-025	FIRE AND EMERGENCY SEVERE SERVICE NON-ASBESTOS REAR BRAKE LINING		
434-005	BRAKE CAMS AND CHAMBERS ON FORWARD SIDE OF DRIVE AXLE(S) WITH AUXILIARY SUPPORT BRACKETS		
451-023	CONMET CAST IRON REAR BRAKE DRUMS		
440-006	REAR OIL SEALS		
426-074	HALDEX GOLDSEAL LONGSTROKE 1-DRIVE AXLE SPRING PARKING CHAMBERS		
428-003	HALDEX AUTOMATIC REAR SLACK ADJUSTERS		
41T-001	MINERAL SAE 80/90 REAR AXLE LUBE		
Rear Suspension			
	AFTERMARKET LIQUID SPRING INSTALLATION		
Brake System			
018-002	AIR BRAKE PACKAGE		
490-100	WABCO 4S/4M ABS		
871-001	REINFORCED NYLON, FABRIC BRAID AND WIRE BRAID CHASSIS AIR LINES		
904-001	FIBER BRAID PARKING BRAKE HOSE		
412-001	STANDARD BRAKE SYSTEM VALVES		
46D-001	STANDARD AIR SYSTEM PRESSURE PROTECTION AND 85 PSI PRESSURE PROTECTION FOR AIR HORN(S)		
413-002	STD U.S. FRONT BRAKE VALVE		

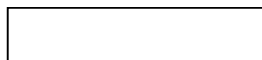

Prepared for:
 Paul Marshall
 OSAGE AMBULANCE INC
 194 TWIN RIDGE RD



LINN, MO 65051
 Phone: 314-566-4991

Prepared by:
 Rick Kinney
 TRUCK CTY OF WISCONSIN,
 INC.
 2401 PROGRESS WAY
 KAUKAUNA, WI 541309559
 Phone: 920-766-5222

Data Code	Description	Weight Front	Weight Rear
432-003	RELAY VALVE WITH 5-8 PSI CRACK PRESSURE, NO REAR PROPORTIONING VALVE		
480-086	BW AD-9SI BRAKE LINE AIR DRYER WITH HEATER		
479-012	AIR DRYER MOUNTED UNDER HOOD		
460-008	STEEL AIR BRAKE RESERVOIRS MOUNTED INSIDE RAIL		
46A-023	(1) 1730 CUBIC INCH AIR HORN TANK, 85 PSI PRESSURE PROTECTED INLET WITH CHECK VALVE AND QUICK DISCONNECT FITTING	20	25
607-001	CLEAR FRAME RAILS FROM BACK OF CAB TO FRONT REAR SUSPENSION BRACKET, BOTH RAILS OUTBOARD		
477-006	BW DV-2 AUTO DRAIN VALVE WITHOUT HEATER ON ALL TANK(S)		

Trailer Connections

296-010	PRIMARY CONNECTOR/RECEPTACLE WIRED FOR SEPARATE STOP/TURN, ABS CENTER PIN POWERED THROUGH IGNITION		
297-001	SAE J560 7-WAY PRIMARY TRAILER CABLE RECEPTACLE MOUNTED END OF FRAME	5	5
335-004	UPGRADED CHASSIS MULTIPLEXING UNIT		
32A-002	UPGRADED BULKHEAD MULTIPLEXING UNIT		

Wheelbase & Frame

545-442	4425MM (174 INCH) WHEELBASE		
546-094	9/32X3-7/16X10-1/16 INCH STEEL FRAME (7.14MMX255.6/0.281X10.06 INCH) 80KSI	-60	-10
552-042	1950MM (77 INCH) REAR FRAME OVERHANG		
55W-007	FRAME OVERHANG RANGE: 71 INCH TO 80 INCH	-20	80
AC8-99D	CALC'D BACK OF CAB TO REAR SUSP C/L (CA) : 108.66 in		
AE8-99D	CALCULATED EFFECTIVE BACK OF CAB TO REAR SUSPENSION C/L (CA) : 105.66 in		
AE4-99D	CALC'D FRAME LENGTH - OVERALL : 289.99 in		
FSS-0LH	CALCULATED FRAME SPACE LH SIDE : 118.26 in		
FSS-0RH	CALCULATED FRAME SPACE RH SIDE : 136.61 in		
AM6-99D	CALC'D SPACE AVAILABLE FOR DECKPLATE : 102.45 in		
553-001	SQUARE END OF FRAME		
550-001	FRONT CLOSING CROSSMEMBER		

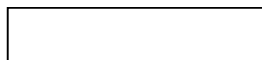

Prepared for:
Paul Marshall
OSAGE AMBULANCE INC
194 TWIN RIDGE RD



LINN, MO 65051
Phone: 314-566-4991

Prepared by:
Rick Kinney
TRUCK CTY OF WISCONSIN,
INC.
2401 PROGRESS WAY
KAUKAUNA, WI 541309559
Phone: 920-766-5222

Data Code	Description	Weight Front	Weight Rear
559-001	STANDARD WEIGHT ENGINE CROSSMEMBER		
561-001	STANDARD CROSSMEMBER BACK OF TRANSMISSION		
562-001	STANDARD MIDSHIP #1 CROSSMEMBER(S)		
572-001	STANDARD REARMOST CROSSMEMBER		
565-001	STANDARD SUSPENSION CROSSMEMBER		
Chassis Equipment			
556-1AR	THREE-PIECE 14 INCH CHROMED STEEL BUMPER WITH COLLAPSIBLE ENDS	30	
558-001	FRONT TOW HOOKS - FRAME MOUNTED	15	
574-001	BUMPER MOUNTING FOR SINGLE LICENSE PLATE		
586-024	FENDER AND FRONT OF HOOD MOUNTED FRONT MUDFLAPS		
551-017	GRADE 8 THREADED HEX HEADED FRAME FASTENERS INSTALLED WITH BOLT HEADS ON OUTSIDE OF FRAME		
Fuel Tanks			
204-998	NO LH FUEL TANK	-60	-20
230-043	40 GALLON/151 LITER RECTANGULAR STEEL FUEL TANK - BETWEEN RAILS		160
218-005	RECTANGULAR FUEL TANK(S)		
215-009	PAINTED FUEL TANK(S), PAINTED STRAPS WITH RUBBER ISOLATORS		
231-004	FUEL TANK(S) MOUNTED BETWEEN RAILS AFT OF REAR AXLE	10	155
664-001	PLAIN STEP FINISH		
205-060	LH SIDEFILL FUEL TANK PREP CAP		
122-1J2	DETROIT FUEL/WATER SEPARATOR WITH WATER IN FUEL SENSOR AND HAND PRIMER	-5	
216-001	SINGLE SUCTION AND RETURN FUEL LINES		
20E-001	AUXILIARY FUEL SUPPLY AND RETURN PORTS		
202-016	HIGH TEMPERATURE REINFORCED NYLON FUEL LINE		
847-002	IN TANK FUEL LEVEL SENDER(S)		
Tires			
093-0BN	MICHELIN XZE 255/70R22.5 16 PLY RADIAL FRONT TIRES	-34	
094-0BN	MICHELIN XZE 255/70R22.5 16 PLY RADIAL REAR TIRES		-68
Hubs			

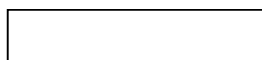

Prepared for:
 Paul Marshall
 OSAGE AMBULANCE INC
 194 TWIN RIDGE RD



LINN, MO 65051
 Phone: 314-566-4991

Prepared by:
 Rick Kinney
 TRUCK CTY OF WISCONSIN,
 INC.
 2401 PROGRESS WAY
 KAUKAUNA, WI 541309559
 Phone: 920-766-5222

Data Code	Description	Weight Front	Weight Rear
418-060	CONMET PRESET PLUS PREMIUM IRON FRONT HUBS		
450-060	CONMET PRESET PLUS PREMIUM IRON REAR HUBS		
Wheels			
502-693	ALCOA LVL ONE 88267X 22.5X8.25 10-HUB PILOT 5.80 INSET ALUMINUM DISC FRONT WHEELS	-56	
505-693	ALCOA LVL ONE 88267X 22.5X8.25 10-HUB PILOT ALUMINUM DISC REAR WHEELS		-112
524-001	POLISHED FRONT WHEELS; OUTSIDE ONLY		
525-001	POLISHED REAR WHEELS; OUTSIDE OF OUTER WHEELS ONLY		
52M-004	FORCEMATCH TIRE/WHEEL RUNOUT CHECK/MARK AND STATIC BALANCING - ALL TIRES/WHEELS		
496-011	FRONT WHEEL MOUNTING NUTS		
497-011	REAR WHEEL MOUNTING NUTS		
495-998	NO PUSHER/TAG WHEEL MOUNTING NUTS		
Cab Exterior			
829-071	106 INCH BBC FLAT ROOF ALUMINUM CONVENTIONAL CAB		
650-009	RUBBER CAB MOUNTS		
678-018	LH AND RH EXTERIOR GRAB HANDLES WITH SINGLE RUBBER INSERT		
646-023	HOOD MOUNTED CHROMED PLASTIC GRILLE		
65X-003	CHROME HOOD MOUNTED AIR INTAKE GRILLE		
644-004	FIBERGLASS HOOD		
690-002	TUNNEL/FIREWALL LINER		
727-1B0	DUAL 25 INCH ROUND STUTTER TONE HOOD MOUNTED AIR HORNS	8	
726-002	DUAL ELECTRIC HORNS		
728-002	DUAL HORN SHIELDS		
657-001	DOOR LOCKS AND IGNITION SWITCH KEYED THE SAME		
78G-002	KEY QUANTITY OF 2		
575-001	REAR LICENSE PLATE MOUNT END OF FRAME		
312-038	INTEGRAL HEADLIGHT/MARKER ASSEMBLY WITH CHROME BEZEL		
302-047	LED AERODYNAMIC MARKER LIGHTS		

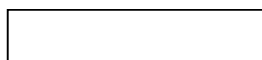

Prepared for:
 Paul Marshall
 OSAGE AMBULANCE INC
 194 TWIN RIDGE RD



LINN, MO 65051
 Phone: 314-566-4991

Prepared by:
 Rick Kinney
 TRUCK CTY OF WISCONSIN,
 INC.
 2401 PROGRESS WAY
 KAUKAUNA, WI 541309559
 Phone: 920-766-5222

Data Code	Description	Weight Front	Weight Rear
311-019	HEADLIGHTS ON WITH WIPERS, WITH DAYTIME RUNNING LIGHTS		
294-046	OMIT STOP/TAIL/BACKUP LIGHTS AND PROVIDE WIRING WITH SEPARATE STOP/TURN WIRES TO 4 FEET BEYOND END OF FRAME		-5
300-015	STANDARD FRONT TURN SIGNAL LAMPS		
744-1BC	DUAL WEST COAST BRIGHT FINISH HEATED MIRRORS WITH LH AND RH REMOTE		
797-001	DOOR MOUNTED MIRRORS		
796-001	102 INCH EQUIPMENT WIDTH		
743-204	LH AND RH 8 INCH BRIGHT FINISH CONVEX MIRRORS MOUNTED UNDER PRIMARY MIRRORS		
74A-001	RH DOWN VIEW MIRROR		
729-001	STANDARD SIDE/REAR REFLECTORS		
677-016	DUAL LEVEL CAB ENTRY STEPS ON BOTH SIDES		
764-010	COMPOSITE EXTERIOR SUN VISOR	10	
768-998	NO REAR WINDOW	-20	
661-004	TINTED DOOR GLASS LH AND RH WITH TINTED OPERATING WING WINDOWS		
654-027	RH AND LH ELECTRIC POWERED WINDOWS, PASSENGER SWITCHES ON DOOR(S)	4	
663-013	1-PIECE SOLAR GREEN GLASS WINDSHIELD		
659-019	2 GALLON WINDSHIELD WASHER RESERVOIR WITHOUT FLUID LEVEL INDICATOR, FRAME MOUNTED		

Cab Interior

707-1AK	OPAL GRAY VINYL INTERIOR		
706-016	MOLDED DOOR PANEL WITH UPPER VINYL INSERTS		
708-016	MOLDED DOOR PANEL WITH UPPER VINYL INSERTS		
772-006	BLACK MATS WITH SINGLE INSULATION		
691-014	FORWARD ROOF MOUNTED CONSOLE WITH UPPER STORAGE COMPARTMENTS AND ADDITIONAL CENTER COMPARTMENT WITHOUT NETTING		
694-010	IN DASH STORAGE BIN		
742-007	(2) CUP HOLDERS LH AND RH DASH		
680-006	GRAY/CHARCOAL FLAT DASH		
860-004	SMART SWITCH EXPANSION MODULE		

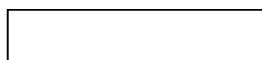

Prepared for:
 Paul Marshall
 OSAGE AMBULANCE INC
 194 TWIN RIDGE RD



LINN, MO 65051
 Phone: 314-566-4991

Prepared by:
 Rick Kinney
 TRUCK CTY OF WISCONSIN,
 INC.
 2401 PROGRESS WAY
 KAUKAUNA, WI 541309559
 Phone: 920-766-5222

Data Code	Description	Weight Front	Weight Rear
700-002	HEATER, DEFROSTER AND AIR CONDITIONER		
701-001	STANDARD HVAC DUCTING		
703-005	MAIN HVAC CONTROLS WITH RECIRCULATION SWITCH		
689-803	PREP KIT FOR CUSTOMER INSTALLED AUXILIARY HEATER, PLUMBING FROM ENGINE TO BACK OF CAB WITH SHUTOFF VALVES		
170-015	STANDARD HEATER PLUMBING		
724-001	AUXILIARY HEATER PLUMBING		
130-043	(1) VALEO HEAVY DUTY AND (1) SANDEN COMPACT REFRIGERANT COMPRESSORS	20	
702-002	BINARY CONTROL, R-134A		
739-034	PREMIUM INSULATION		
285-013	SOLID-STATE CIRCUIT PROTECTION AND FUSES		
280-007	12V NEGATIVE GROUND ELECTRICAL SYSTEM		
324-011	DOME DOOR ACTIVATED LH AND RH, DUAL READING LIGHTS, FORWARD CAB ROOF		
655-005	LH AND RH ELECTRIC DOOR LOCKS		
284-023	(1) 12 VOLT POWER SUPPLY IN DASH		
756-1E7	SEATS INC 911 UNIVERSAL SERIES HIGH BACK AIR SUSPENSION DRIVER SEAT WITH NFPA 1901-2009/2016 COMPLIANT SEAT SENSOR	50	
760-1E7	SEATS INC 911 UNIVERSAL SERIES HIGH BACK AIR SUSPENSION PASSENGER SEAT WITH NFPA 1901-2009/2016 COMPLIANT SEAT SENSOR	40	15
759-002	INBOARD DRIVER AND PASSENGER SEAT ARMRESTS	4	
711-004	LH AND RH INTEGRAL DOOR PANEL ARMRESTS		
758-036	VINYL WITH VINYL INSERT DRIVER SEAT		
761-036	VINYL WITH VINYL INSERT PASSENGER SEAT		
763-105	NFPA 1901-2009 HIGH VISIBILITY ORANGE SEAT BELTS		
532-002	ADJUSTABLE TILT AND TELESCOPING STEERING COLUMN	10	
540-015	4-SPOKE 18 INCH (450MM) STEERING WHEEL		
765-002	DRIVER AND PASSENGER INTERIOR SUN VISORS		

Instruments & Controls

732-003	WOODGRAIN DRIVER INSTRUMENT PANEL
734-003	WOODGRAIN CENTER INSTRUMENT PANEL



Prepared for:
 Paul Marshall
 OSAGE AMBULANCE INC
 194 TWIN RIDGE RD



LINN, MO 65051
 Phone: 314-566-4991

Prepared by:
 Rick Kinney
 TRUCK CTY OF WISCONSIN,
 INC.
 2401 PROGRESS WAY
 KAUKAUNA, WI 541309559
 Phone: 920-766-5222

Data Code	Description	Weight Front	Weight Rear
87L-003	ENGINE REMOTE INTERFACE WITH PARK BRAKE AND NEUTRAL INTERLOCKS		
870-001	BLACK GAUGE BEZELS		
486-001	LOW AIR PRESSURE INDICATOR LIGHT AND AUDIBLE ALARM		
840-002	2 INCH PRIMARY AND SECONDARY AIR PRESSURE GAUGES		
198-003	DASH MOUNTED AIR RESTRICTION INDICATOR WITH GRADUATIONS		
149-013	ELECTRONIC CRUISE CONTROL WITH SWITCHES IN LH SWITCH PANEL		
156-007	KEY OPERATED IGNITION SWITCH AND INTEGRAL START POSITION; 4 POSITION OFF/RUN/START/ACCESSORY		
811-042	ICU3S, 132X48 DISPLAY WITH DIAGNOSTICS, 28 LED WARNING LAMPS AND DATA LINKED		
160-038	HEAVY DUTY ONBOARD DIAGNOSTICS INTERFACE CONNECTOR LOCATED BELOW LH DASH		
844-001	2 INCH ELECTRIC FUEL GAUGE		
148-070	ENGINE REMOTE INTERFACE WITH PRESET FAST IDLE		
163-004	ENGINE REMOTE INTERFACE CONNECTOR IN ENGINE COMPARTMENT		
856-001	ELECTRICAL ENGINE COOLANT TEMPERATURE GAUGE		
864-001	2 INCH TRANSMISSION OIL TEMPERATURE GAUGE		
830-017	ENGINE AND TRIP HOUR METERS INTEGRAL WITHIN DRIVER DISPLAY		
852-002	ELECTRIC ENGINE OIL PRESSURE GAUGE		
679-998	NO OVERHEAD INSTRUMENT PANEL		
746-135	AM/FM/WB WORLD TUNER RADIO WITH SIRIUSXM, BLUETOOTH, IPOD INTERFACE, USB AND AUXILIARY INPUTS, J1939	10	
747-001	DASH MOUNTED RADIO		
750-002	(2) RADIO SPEAKERS IN CAB		
753-001	AM/FM ANTENNA MOUNTED ON FORWARD LH ROOF		
78C-003	INTEROPERABLE SDAR ANTENNA		
810-027	ELECTRONIC MPH SPEEDOMETER WITH SECONDARY KPH SCALE, WITHOUT ODOMETER		
817-001	STANDARD VEHICLE SPEED SENSOR		



Prepared for:
 Paul Marshall
 OSAGE AMBULANCE INC
 194 TWIN RIDGE RD



LINN, MO 65051
 Phone: 314-566-4991

Prepared by:
 Rick Kinney
 TRUCK CTY OF WISCONSIN,
 INC.
 2401 PROGRESS WAY
 KAUKAUNA, WI 541309559
 Phone: 920-766-5222

Data Code	Description	Weight Front	Weight Rear
812-001	ELECTRONIC 3000 RPM TACHOMETER		
162-002	IGNITION SWITCH CONTROLLED ENGINE STOP		
264-028	(2) LH AND RH FOOT SWITCHES WITH DASH SWITCH FOR HORN BUTTON TO CONTROL AIR HORN, DEFAULT TO ELECTRIC <85 PSI		
836-015	DIGITAL VOLTAGE DISPLAY INTEGRAL WITH DRIVER DISPLAY		
660-008	SINGLE ELECTRIC WINDSHIELD WIPER MOTOR WITH DELAY		
304-001	MARKER LIGHT SWITCH INTEGRAL WITH HEADLIGHT SWITCH		
27D-004	ALTERNATING FLASHING HEADLAMP SYSTEM WITH BODY BUILDER CONTROLLED ENGAGEMENT		
882-009	ONE VALVE PARKING BRAKE SYSTEM WITH WARNING INDICATOR		
299-013	SELF CANCELING TURN SIGNAL SWITCH WITH DIMMER, WASHER/WIPER AND HAZARD IN HANDLE		
298-039	INTEGRAL ELECTRONIC TURN SIGNAL FLASHER WITH HAZARD LAMPS OVERRIDING STOP LAMPS		

Design

065-000 PAINT: ONE SOLID COLOR

Color

980-5F6 CAB COLOR A: L0006EY WHITE ELITE EY
 986-020 BLACK, HIGH SOLIDS POLYURETHANE CHASSIS PAINT
 976-995 SUNVISOR PAINTED SAME AS CAB COLOR A
 963-003 STANDARD E COAT/UNDERCOATING

Certification / Compliance

996-001 U.S. FMVSS CERTIFICATION, EXCEPT SALES CABS AND GLIDER KITS

Secondary Factory Options

998-033 CORPORATE PDI CENTER IN-SERVICE AND OPTION INSTALLATION/MODIFICATION

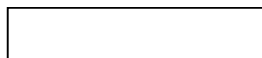

Prepared for:
 Paul Marshall
 OSAGE AMBULANCE INC
 194 TWIN RIDGE RD



LINN, MO 65051
 Phone: 314-566-4991

Prepared by:
 Rick Kinney
 TRUCK CTY OF WISCONSIN,
 INC.
 2401 PROGRESS WAY
 KAUKAUNA, WI 541309559
 Phone: 920-766-5222

Data Code	Description	Weight Front	Weight Rear
99B-001	SHIP TO FONTAINE (MOUNT HOLLY, NC) PRIOR TO LIQUID SPRING INSTALLATION PERFORMED AT FONTAINE MODIFICATION IN CHARLOTTE NC. LIQUID SPRING IS NOT A FREIGHTLINER OR DEALER INSTALLED OPTION AND IS NOT COVERED BY FREIGHTLINER WARRANTY, ANY LIQUID SPRING SERVICE NEEDS TO BE PROVIDED BY LIQUID SPRING AND/OR THEIR DEALERS, CUSTOMER MUST ASSUME RESPONSIBILITY FOR ANY CHARGES. ANY ADJUSTMENTS OR CHASSIS DIAGNOSTICS RELATED TO THE REMOVAL OF THE FACTORY SUSPENSION AND/OR HANDLING CHARACTERISTICS ARE NOT COVERED UNDER THE FREIGHTLINER WARRANTY. DELIVERY		

Raw Performance Data

AE8-99D	CALCULATED EFFECTIVE BACK OF CAB TO REAR SUSPENSION C/L (CA) : 105.66 in
AM6-99D	CALC'D SPACE AVAILABLE FOR DECKPLATE : 102.45 in

T O T A L V E H I C L E S U M M A R Y

Weight Summary

	Weight Front	Weight Rear	Total Weight
Factory Weight ⁺	6022 lbs	3603 lbs	9625 lbs
Total Weight ⁺	6022 lbs	3603 lbs	9625 lbs

Extended Warranty

WBB-344	TC4: MD MODERATE 5 YEARS/100,000 MILES / 161,000 KM EXTENDED TRUCK COVERAGE. FEX APPLIES
WAG-010	TOWING: 1 YEAR/UNLIMITED MILES/KM EXTENDED TOWING COVERAGE \$550 CAP FEX APPLIES

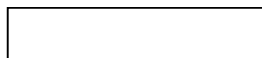

Prepared for:
Paul Marshall
OSAGE AMBULANCE INC
194 TWIN RIDGE RD

LINN, MO 65051
Phone: 314-566-4991

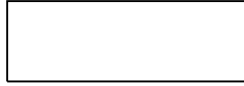

Prepared by:
Rick Kinney
TRUCK CTY OF WISCONSIN,
INC.
2401 PROGRESS WAY
KAUKAUNA, WI 541309559
Phone: 920-766-5222

(+) Weights shown are estimates only.
If weight is critical, contact Customer Application Engineering.

(***) All cost increases for major components (Engines, Transmissions, Axles, Front and Rear Tires) and government mandated requirements, tariffs, and raw material surcharges will be passed through and added to factory invoices.

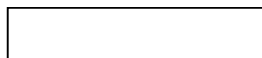



IN SERVICE TO SERVE YOU

TEN-8 FIRE & SAFETY, LLC
2904 59TH AVENUE DRIVE EAST
BRADENTON, FL 34203
Phone : 800-228-8368
Fax : 941-756-2598

Sales Quote

Page: 1

Sales Quote Number: Q226830
Sales Quote Date: 10/25/2021

Customer ID: TEN-8
SalesPerson: Mark Higgins
Email: mhiggins@ten8fire.com
Ten-8 Contact: Andrew Stinger
Email: astinger@ten8fire.com

Sell To:
BROWARD CO. SHERIFF'S OFFICE
FINANCE DIVISION
P.O. BOX 9507
FT. LAUDERDALE, FL 33310

Ship To:
OSAGE INDUSTRIES
194 TWIN RIDGE ROAD
LINN, MO 65051

Payment Terms : Due Upon Receipt of
Product Or Service

Ship Via : !!!!!!!!!!!!!!!!!!!SALES TO
FURNISH!!!!!!!!!!!!!!!!!!

Table with 6 columns: Item No., Description, Unit, Quantity, Selling Pric, Total Price. Contains multiple rows of item details including RUG-6506, FIR-5200D, FIR-HM10, etc.

Amount Subject to Sales Tax 0
Amount Exempt from Sales Tax 28,203.11

Subtotal: 28203.11
Invoice Discount: 0.00
Total Sales Tax: 0.00
Total: 28,203.11

This Quote is valid until 11/25/21

All returns must be initiated within 30 days of receipt of product and will be charged a restocking fee. Contact your sales representative to receive a Return Materials Authorization (RMA). Special order parts are not returnable. Full terms and conditions for returns can be found on our website at www.ten8fire.com/returns.

EXHIBIT B

WARRANTY



Emergency Vehicle Limited Warranty

TYPE I & III MODULARS

Subject to limitations, provisions and conditions set forth in this Warranty, Osage Industries, Inc. does hereby warrant to each Original Purchaser Only that each new vehicle conversion is free from defects and workmanship and materials used in the construction of a production model emergency vehicle for a period as follows:

A. **PRODUCT CONVERSION WARRANTY**

For **THREE 3 years or 36,000 miles**, whichever comes first, from the date of the original purchase. Osage Industries, Inc. will repair or replace, at no cost to purchaser, only those components manufactured by Osage Industries, Inc. for use in a production vehicle and excludes components from other manufacturers used in such conversions; i.e. sirens, inverters, lightbars, oxygen equipment, auto eject, siren drivers and chassis, etc. Individual warranties are covered by those manufacturers included in the Owner's Manual as supplied with the vehicle and shall apply as set forth by said manufacturer. Osage will only reimburse labor up to (3) years on those components with more than a (3) year warranty.

B. **ELECTRICAL WARRANTY**

For **SIX (6) years or 72,000 miles**, whichever comes first, from the date of the original purchase, Osage Industries, Inc. will cover the cost of labor and material, in the repair or replacement of the electrical systems furnished and installed by Osage Industries, Inc. This warranty shall include switch panels, electrical harnesses (and the installation), printed circuit boards and general design concept used by Osage Industries, Inc. at the time of manufacture. This warranty shall not apply to any electrical equipment furnished and warranted by other manufacturers. All other components are excluded from the coverage of this limited electrical warranty. **Extended Warranty if Purchased:** For up to **Seven 7 years or 100,000 miles** on electrical stated above.

C. **ALUMINUM MODULE BODY AND INTERIOR ALUMINUM CABINET STRUCTURE**

Lifetime warranted to the original purchaser, on the original chassis. This warranty can be transferred onto a new chassis, providing the remount is performed by Osage. At that time, Osage will thoroughly inspect and repair, if needed. **Door Hardware, Cabinet Finish and Latches** are warranted for a period of Three (3) years or 36,000 miles, whichever comes first from date of original purchase for defects under normal use; this does not include adjustments.

D. **PAINT WARRANTY 5 YEARS OR 100,000 MILES**

Complete, NON-PRO RATED warranty covers paint finish, corrosion and blistering of the ambulance body. Warranty covers the cost of parts and labor. Unless installed by Osage, lettering and graphics replacement due to paint failure will not be covered. Warranty is dependent on agreement by both parties (purchaser and seller) that failure is due to a manufacturing defect.

E. **GRAPHICS WARRANTY 3 YEARS OR 36,000 MILES**

Osage warrants its graphics and lettering package to be free from defects in material and workmanship for **three (3) years or 36,000 miles**. Warranty covers cost of parts and labor. Osage will not be liable for more than the amount of the purchase price of the graphics package.

The above warranties are conditioned upon normal use and reasonable maintenance and do not apply to any components, which have been subject to abuse, accident, alteration, vandalism, and improper or careless use. Any modification of any description made to any components on the conversion, without written approval by Osage Industries, Inc. shall void the warranty of said system and components parts.

Prompt written notice of all defects or claims against Osage shall be forwarded to Osage Industries, Inc., P.O. Box 718, Linn, Missouri (MO) 65051, or by calling at 800-822-3634. No repairs or additions shall be performed without prior approval from Osage Industries, Inc. Osage Industries, Inc. reserves the right to reject unauthorized claims and its decision in these matters shall be final.

If warranty repairs are necessary, all work must be performed by Osage Industries, Inc. or repair center authorized by Osage Industries, Inc. It is the responsibility of the purchaser to transport vehicle to and from Osage Industries, Inc., Linn, Missouri (MO), or repair center authorized by Osage Industries, Inc. for warranty repairs. Osage is not responsible for any loss or damage that may occur during said transportation.

Any expressed warranty not provided herein and any remedy for breach of contract which might arise by implication or operation of law, is hereby excluded and disclaimed. The implied warranties of merchantability and fitness for any particular purpose are expressly limited to the terms stated above. Some states do not allow limitations on how long an implied warranty lasts. Therefore, the above limitations may not apply to you. Osage is not responsible for any loss or damage that may occur during said transportation.

Under no circumstances shall Osage Industries, Inc. be liable to purchaser or any other person for any special or consequential damages, whether arising out of breach of warranty, breach of contract, or otherwise. Some states do not allow the exclusion or limitation of incidental or consequential damages. Therefore, the above limitations or exclusions may not apply to you.

This Warranty gives you specific legal rights, and you may have other rights, which vary, from state to state.

EXHIBIT C

PURCHASING TERMS AND CONDITIONS

PURCHASING TERMS AND CONDITIONS

(Florida)

These Purchasing Terms and Conditions, together with the Equipment Proposal and all attachments (collectively, the "Agreement") are entered into by and between Ten-8 Fire & Safety, LLC, a Florida company ("Company") and Customer (as defined in Ten-8 Fire & Safety, LLC's Equipment Proposal document) and is effective as of the date specified in Section 3 of these Purchasing Terms and Conditions. Both Company and Customer may be referred throughout this document individually as a "party" or collectively as the "parties."

1. Definitions.

- a. **"Acceptance"** has the same meaning set forth in Company's Equipment Proposal.
- b. **"Company's Equipment Proposal"** means the Equipment Proposal provided by Company and prepared in response to Customer's request for proposal for a fire apparatus, associated equipment or an ambulance.
- c. **"Cooperative Purchasing Contract"** means an Agreement between Company and a public authority, including without limitation, a department, division, agency of a municipal, county or state government ("Public Authority"), that adopts or participates in an existing agreement between Company and another non-party customer (including, but not limited to such non-party customer's equipment proposal, its applicable exhibits, attachments and purchasing terms and conditions), often referred to as a "piggyback arrangement," which is expressly agreed to, in writing, by Company. Company has sole discretion to determine whether it will agree to such a Cooperative Purchasing Contract.
- d. **"Delivery"** means when Company delivers physical possession of the Product to Customer.
- e. **"Manufacturer"** means the Manufacturer of any Product.
- f. **"Prepayment Discount"** means the prepayment discounts, if any, specified in Company's Equipment Proposal.
- g. **"Product"** means the fire apparatus and any associated equipment, or ambulance manufactured or furnished for Customer by Company pursuant to the Specifications.
- h. **"Purchasing Terms and Conditions"** means these Purchasing Terms and Conditions; however, if the Company's Equipment Proposal or the Customer's related Purchase Order states that it is governed by a Cooperative Purchasing Agreement, "Purchasing Terms and Conditions" shall mean those terms and conditions set forth in the applicable Cooperative Purchasing Agreement.
- i. **"Specifications"** means the general specifications, technical specifications, training, and testing requirements for the Product contained in Company's Equipment Proposal and its Exhibit A (Proposal Option List or for ambulance sales, the Quotation, or Order Form, as applicable), prepared in response to Customer's request for such a proposal.

2. Purpose. This Agreement sets forth the terms and conditions of Company's sale of the Product to Customer.

3. Term of Agreement. This Agreement will become effective on the date of Acceptance as defined in Company's Equipment Proposal ("Effective Date") and, unless earlier terminated pursuant to the terms of this Agreement, it will terminate upon Delivery and payment in full of the Purchase Price.

4. Purchase and Payment. Customer agrees to pay Company the Purchase Price for the Product(s) as set forth in Company's Equipment Proposal ("Purchase Price"). The Purchase Price is in U.S. dollars. Where Customer opts for a Prepayment Discount that specifies that Customer will tender one or more prepayments to Company, Customer must provide each prepayment within the time frame specified in the Equipment Proposal in order to receive the Prepayment Discount for that prepayment installment.

5. Representations and Warranties. Customer hereby represents and warrants to Company that the purchase of the Product(s) has been approved by Customer in accordance with applicable general laws and, as applicable, Customer's charter, ordinances and other governing documents, and funding for the purchase has been duly budgeted and appropriated.

6. Cancellation/Termination.

- a. Fire Equipment and Apparatus Sales. In the event this Agreement is cancelled or terminated by Customer before completion, Company may charge Customer a cancellation fee. The following charge schedule is based on costs incurred by Manufacturer and Company for the Product, which may be applied and charged to Customer: (a) 12% of the Purchase Price after the order for the Product(s) is accepted and entered into Manufacturer's system by Company; (b) 22% of

the Purchase Price after completion of approval drawings by Customer, and; (c) 32% of the Purchase Price upon any material requisition made by the Manufacturer for the Product. The cancellation fee will increase in excess of (c) in this Section 6, accordingly, as additional costs are incurred by Manufacturer and Company as the order progresses through engineering and into the manufacturing process.

- b. Ambulance Sales. This Section 6 for Cancellation/Termination does not apply to Ambulance Sales. An order for an ambulance cannot be cancelled or terminated once Company receives and processes Customer's Acceptance of Company's Equipment Proposal.
7. Delivery. The Product is scheduled to be delivered as specified in the Delivery Timing section of the Equipment Proposal ("Delivery Timing"), which will be F.O.B. Company's facility. The Delivery Timing is an estimate, and Company is not bound to such date unless it otherwise agrees in writing. Company is not responsible for Delivery delays caused by or as the result of actions, omissions or conduct of the Manufacturer, its employees, affiliates, suppliers, contractors, and carriers. All right, title and interest in and to the Product, and risk of loss, shall pass to Customer upon Delivery of the Product(s) to Customer.
8. Standard Warranty. The manufacturer warranties applicable to this Agreement, if any, are attached to Company's Equipment Proposal as Exhibit A and are incorporated herein as part of the Agreement.
 - a. Disclaimer. EXCEPT AS OTHERWISE SET FORTH IN THIS AGREEMENT, COMPANY, INCLUDING ITS PARENT COMPANY, AFFILIATES, SUBSIDIARIES, AND THEIR RESPECTIVE OFFICERS, DIRECTORS, EMPLOYEES, SHAREHOLDERS, AGENTS OR REPRESENTATIVES DO NOT MAKE ANY REPRESENTATIONS OR WARRANTIES, EXPRESS OR IMPLIED, WITH RESPECT TO THE PRODUCTS PROVIDED UNDER THIS AGREEMENT, WHETHER ORAL OR WRITTEN, EXPRESS, IMPLIED OR STATUTORY. WITHOUT LIMITING THE FOREGOING DISCLAIMER, ANY IMPLIED WARRANTY OR CONDITION OF MERCHANTABILITY, IMPLIED WARRANTY AGAINST INFRINGEMENT, AND IMPLIED WARRANTY OR CONDITION OF FITNESS FOR A PARTICULAR PURPOSE ARE EXPRESSLY EXCLUDED AND DISCLAIMED. STATEMENTS MADE BY SALES REPRESENTATIVES OR IN PROMOTIONAL MATERIALS DO NOT CONSTITUTE WARRANTIES.
9. Limitation of Liability. COMPANY WILL NOT BE LIABLE FOR ANY INCIDENTAL, CONSEQUENTIAL, INDIRECT, ECONOMIC, PUNITIVE, SPECIAL OR EXEMPLARY DAMAGES ARISING FROM OR IN ANY WAY CONNECTED WITH THIS AGREEMENT WITHOUT REGARD TO THE NATURE OF THE CLAIM OR THE UNDERLYING THEORY OR CAUSE OF ACTION (WHETHER IN CONTRACT, TORT, STRICT LIABILITY, EQUITY OR ANY OTHER THEORY OF LAW) ON WHICH SUCH DAMAGES ARE BASED. COMPANY'S LIMIT OF LIABILITY UNDER THIS AGREEMENT SHALL BE CAPPED AT THE TOTAL AMOUNT OF THE MONIES PAID BY CUSTOMER TO COMPANY UNDER THIS AGREEMENT.
10. Force Majeure. Company shall not be responsible nor deemed to be in default on account of delays in performance due to causes which are beyond Company's control which make Company's performance impracticable, including but not limited to civil wars, insurrections, strikes, riots, fires, storms, floods, other acts of nature, explosions, earthquakes, accidents, including transportation or delivery losses outside of Company's control, any act of government, delays in transportation, inability to obtain necessary labor supplies or manufacturing facilities, allocation regulations or orders affecting materials, equipment, facilities or completed products, failure to obtain any required license or certificates, acts of God or the public enemy or terrorism, failure of transportation, epidemics, quarantine restrictions, failure of vendors (due to causes similar to those within the scope of this clause) to perform their contracts or labor troubles causing cessation, slowdown, or interruption of work.
11. Customer's Obligations. Customer shall provide its timely and best efforts to cooperate with Company and Manufacturer during the manufacturing process to create the Product. Reasonable and timely cooperation includes, without limitation, Customer's providing timely information in response to a request from Manufacturer or Company and Customer's participation in traveling to Manufacturer's facility for inspections and approval of the Product.

12. Default. The occurrence of one or more of the following shall constitute a default under this Agreement: (a) Customer's failure to pay any amounts due under this Agreement or Customer's failure to perform any of its obligations under this Agreement; (b) Company's failure to perform any of its obligations under this Agreement; (c) either party becoming insolvent or becoming subject to bankruptcy or insolvency proceedings; (d) any representation made by either party to induce the other to enter into this Agreement, which is false in any material respect; (e) an action by Customer to dissolve, merge, consolidate or transfer a substantial portion of its property to another entity; or (f) a default or breach by Customer under any other contract or agreement with Company.
13. Manufacturer's Statement of Origin. Company shall retain possession of the manufacturer's statement of origin ("MSO") for the Product until the entire Purchase Price has been paid. If more than one Product is covered by this Agreement, Company shall retain the MSO for each individual Product until the Purchase Price for that Product has been paid in full.
14. Arbitration. Any controversy or claim arising out of or relating to this Agreement, or the breach thereof, shall be settled by arbitration administered by the American Arbitration Association in accordance with its Commercial Arbitration Rules, and judgment on the award rendered by the arbitrator(s) may be entered in any court having jurisdiction thereof. The Arbitration shall take place in Bradenton, Florida.
15. Miscellaneous. The relationship of the parties established under this Agreement is that of independent contractors and neither party is a partner, employee, agent, or joint venture of or with the other. Neither party may assign its rights and obligations under this Agreement without the prior written approval of the other party. This Agreement and all transactions between Ten-8 Fire & Safety, LLC will be governed by and construed in accordance with the laws of the State of Florida. The delivery of signatures to this Agreement may be via facsimile transmission or other electronic means and shall be binding as original signatures. This Agreement shall constitute the entire agreement and supersede any prior agreement between the parties concerning the subject matter of this Agreement. This Agreement may only be modified by an amendment, in writing, signed by duly authorized representatives of both parties with authority to sign such amendments to this Agreement. In the event of a conflict between the Ten-8 Proposal and these Terms and Conditions, the Ten-8 Proposal shall control except in the case of a Cooperative Purchasing Contract as set forth in Section 1(c) and (h) of these Purchasing Terms and Conditions. If any term of this Agreement is determined to be invalid or unenforceable by a competent legal authority, such term will be either reformed or deleted, as the case may be, but only to the extent necessary to comply with the applicable law, regulation, order or rule, and the remaining provisions of the Agreement will remain in full force and effect.