

City of Coachella
Bank Reconciliation - Wells Fargo Bank A/C#7100772636
April 30, 2023

	BEGINNING BALANCE	RECEIPT	DISBURSEMENT	ENDING BALANCE	
Bank Statement	10,678,584.06	3,054,573.19	5,925,596.01	7,807,561.24	1
Cleared Deposits in Transit					
Cash & Checks	171,828.54	(171,828.54)		-	2
UB Auto Pay In Transit	-	-		-	
Credit Cards	8,257.09	(8,257.09)			
Deposits in Transit					
Cash & Checks		873,540.21		873,540.21	3
UB Auto Pay In Transit				-	
Credit Cards		2,562.47		2,562.47	4
Last Month's O/S Checks	(2,127,836.66)		(2,127,836.66)	-	
Outstanding Checks			1,848,462.41	(1,848,462.41)	5
Reconciled Bank Balance	8,730,833.03	3,750,590.24	5,646,221.76	6,835,201.51	
Book Balance	8,730,833.03			8,730,833.03	
<u>Daily Cash Received</u>					
Cash Receipts		3,750,590.24		3,750,590.24	6
Book Transfers				0.00	7
Adjusting Journal Entries				0.00	8
<u>Other Fees And Revenues Affecting Cash</u>					
NSF/Chargeback			5,161.10	(5,161.10)	9
Merchant Fees			4,365.68	(4,365.68)	10
Deposit Bags			-	-	11
Currency Purchase and Increase Drawers			1,222.00	(1,222.00)	12
<u>Cash Disbursements</u>					
Payroll transfers			833,668.53	(833,668.53)	13
Checks			5,550,927.51	(5,550,927.51)	14
Voided check(s)			(751,536.26)	751,536.26	15
WF Adjustments		-	-	-	16
AJE2223-04011-Global Payments			2,413.20	(2,413.20)	8
				-	
				-	
				-	
	8,730,833.03	3,750,590.24	5,646,221.76	6,835,201.51	
DIFFERENCE (Short)Over	-	-	(0.00)	0.00	

City of Coachella
Bank Reconciliation - Wells Fargo Bank A/C#7100772636
April 30, 2023

	BEGINNING BALANCE	RECEIPT	DISBURSEMENT	ENDING BALANCE
--	----------------------	---------	--------------	-------------------

GL Balance - Wells Fargo Bank A/C#7100772636

4/30/2023 GL Balance				9,924,925.66	17
Less Road Maint. & Rehab (Wells Fargo)				(1,827,450.05)	18
Less Gas Tax (Wells Fargo Bank)				(1,262,298.22)	19
Less Payroll (Mechanics Bank and WFB)				24.12	20

G/L Balance WF only				6,835,201.51
---------------------	--	--	--	---------------------

DIFFERENCE (Short)Over				-
------------------------	--	--	--	---

Completed by: <u>Lourdes Marron</u>			Date: <u>6/14/2023</u>
-------------------------------------	--	--	------------------------

Reviewed By: _____			Date: _____
--------------------	--	--	-------------

(751,536.26)

Analyzed Business Checking - PF

Account number: 7100772636 ■ April 1, 2023 - April 30, 2023 ■ Page 1 of 8

WELLS
FARGO

CITY OF COACHELLA
GENERAL OPERATING ACCOUNT
53990 ENTERPRISE WAY
COACHELLA CA 92236-2724

Questions?

Call your Customer Service Officer or Client Services
1-800-AT WELLS (1-800-289-3557)
5:00 AM TO 6:00 PM Pacific Time Monday - Friday

Online: wells Fargo.com

Write: Wells Fargo Bank, N.A. (114)
P.O. Box 6995
Portland, OR 97228-6995

Account summary

Analyzed Business Checking - PF

Account number	Beginning balance	Total credits	Total debits	Ending balance
7100772636	\$10,678,584.06	\$3,054,573.19	-\$5,925,596.01	\$7,807,561.24

Credits

Electronic deposits/bank credits

Effective date	Posted date	Amount	Transaction detail
	04/03	274.00	Checkbook Inc Individual Check 8124 Horne LLP DBA CA Lihwap
	04/03	408.61	ACH Origination - Citycoac - File Ebillxprss Coid 3956000693
	04/03	1,770.20	04/03Bankcard Deposit -0482213064
	04/03	1,828.15	Ecs E-Box Settle Ebx Settle 040323 City of Coachel x
	04/03	2,043.41	ACH Origination - Citycoac - File Ebillxprss Coid 3956000693
	04/03	2,591.45	04/03Bankcard Deposit -0482213064
	04/03	5,821.82	04/03Bankcard Deposit -0482213064
	04/03	11,547.83	Riverside Cnty Payment 230403 2740029552 Rmr*IV*Fy23 1/2% Sales Tax 03/23**11547.83\
	04/03	15,294.49	Riverside Cnty Payment 230403 2740029552 Rmr*IV*D00065**15294.49\
	04/03	17,282.03	Coachella Valley AP03.31.23 Coachella Inv St-93-2023-015 Ave 50 Fm Calhoun/Harrison
	04/03	99,464.93	WT Fed#00980 Mufg Union Bank, N /Org=Imperial Irrigation District Srf# 2023040300018739 Trn#230403130974 Rfb# Uboc Ub123501N
	04/04	3,603.96	Ecs E-Box Settle Ebx Settle 040423 City of Coachel x
	04/04	3,961.62	ACH Origination - Citycoac - File Ebillxprss Coid 3956000693
	04/04	5,074.13	04/04Bankcard Deposit -0482213064
	04/04	11,330.23	04/04Bankcard Deposit -0483233883
	04/05	157.51	Capturis Bill Pay 230404 13183 *PO*157.51*157.51\SE*9*000058887\GE*1*000058887\I
	04/05	414.60	Capturis Bill Pay 230404 13183 PO*414.60*414.60\SE*9*000058901\GE*1*000058901\I
	04/05	420.82	Cash Vault Deposit
	04/05	1,296.50	Cash Vault Deposit
	04/05	1,431.72	Cash Vault Deposit

Commercial Checking Acct Public Funds

Account number: 4144869831 ■ April 1, 2023 - April 30, 2023 ■ Page 1 of 1

WELLS
FARGO

CITY OF COACHELLA
ROAD MAINTENANCE & REHABILITATION
1515 6TH ST
COACHELLA CA 92236-1757

Questions?

Call your Customer Service Officer or Client Services
1-800-AT WELLS (1-800-289-3557)
5:00 AM TO 6:00 PM Pacific Time Monday - Friday

Online: wells Fargo.com

Write: Wells Fargo Bank, N.A. (182)
PO Box 63020
San Francisco, CA 94163

Account summary

Commercial Checking Acct Public Funds

Account number	Beginning balance	Total credits	Total debits	Ending balance
4144869831	\$1,747,867.70	\$79,582.35	\$0.00	\$1,827,450.05

Credits

Electronic deposits/bank credits

Effective date	Posted date	Amount	Transaction detail
	04/21	79,582.35	Apport St of CA Apsapports 041823 4180 Coachella City Treasur
		\$79,582.35	Total electronic deposits/bank credits
		\$79,582.35	Total credits

Daily ledger balance summary

Date	Balance	Date	Balance
03/31	1,747,867.70	04/21	1,827,450.05
Average daily ledger balance		\$1,774,395.15	

Analyzed Business Checking - PF

Account number: 7100772644 ■ April 1, 2023 - April 30, 2023 ■ Page 1 of 1



CITY OF COACHELLA
GAS TAX ACCOUNT
53990 ENTERPRISE WAY
COACHELLA CA 92236-2724

Questions?

Call your Customer Service Officer or Client Services
1-800-AT WELLS (1-800-289-3557)
5:00 AM TO 6:00 PM Pacific Time Monday - Friday

Online: wells Fargo.com

Write: Wells Fargo Bank, N.A. (114)
P.O. Box 6995
Portland, OR 97228-6995

Account summary

Analyzed Business Checking - PF

Account number	Beginning balance	Total credits	Total debits	Ending balance
7100772644	\$1,188,975.08	\$73,323.14	\$0.00	\$1,262,298.22

Credits

Electronic deposits/bank credits

Effective date	Posted date	Amount	Transaction detail
	04/03	73,323.14	Apport St of CA Apsapports 032823 588 Coachella City Treasur
		\$73,323.14	Total electronic deposits/bank credits
		\$73,323.14	Total credits

Daily ledger balance summary

Date	Balance	Date	Balance
03/31	1,188,975.08	04/03	1,262,298.22
Average daily ledger balance		\$1,257,410.01	

City of Coachella
Bank Reconciliation -Payroll Account **1679
April 30, 2023

	BEGINNING BALANCE	RECEIPT	DISBURSEMENT	ENDING BALANCE	
Bank Statement-Mechanics	4,880.92	-	4,880.92	-	21
Bank Statement-WFB	67,369.70	838,420.69	666,261.51	239,528.88	
Last Month's Outstanding Checks	(71,396.26)		(71,396.26)	-	
Current Month's Outstanding Checks			239,553.00	(239,553.00)	22
Reconciled Bank Balance	854.36	838,420.69	839,299.17	(24.12)	

Book Balance	854.36			854.36	
Revenue Postings (transfer amt)		838,420.69		838,420.69	13
WFB Adjustments		-	-	-	23
Interest		-		-	24
Bank fees			128.76	(128.76)	24
Voided Checks		-	0.00	-	25
Total Payroll Checks			209,002.13		
Total Direct Deposits			629,418.56	(838,420.69)	26
AJE2223-04005 PERS Emp Cont.			662.70	(662.70)	27
AJE2223-04005 Rounding			(0.11)	0.11	27
AJE2223-04012 Ben/Deds Over/Short			87.13	(87.13)	
				-	
	854.36	838,420.69	839,299.17	(24.12)	
DIFFERENCE	-	0.00	(0.00)	0.00	

GL Balance - Mechanics Bank A/C#0005501679

4/30/2023 GL Balance (Rabo & B of A)	9,924,925.66
Less Road Maint. & Rehab (Wells Fargo)	(1,827,450.05)
Less Gas Tax (Wells Fargo Bank)	(1,262,298.22)
	-
	-
G/L balance both banks	6,835,177.39
Less WF portion	6,835,201.51
G/L Mechanics only	(24.12)
Difference (Short/Over)	0.00

20

Completed by: Lourdes Marron

Date: 6/15/2023

Reviewed By: _____

Date: _____

Commercial Checking Acct Public Funds

Account number: 4943186197 ■ April 1, 2023 - April 30, 2023 ■ Page 1 of 2

WELLS
FARGO

CITY OF COACHELLA
PAYROLL
53990 ENTERPRISE WAY
COACHELLA CA 92236-2724

Questions?

Call your Customer Service Officer or Client Services
1-800-AT WELLS (1-800-289-3557)
5:00 AM TO 6:00 PM Pacific Time Monday - Friday

Online: wells Fargo.com

Write: Wells Fargo Bank, N.A. (182)
PO Box 63020
San Francisco, CA 94163

Account summary

Commercial Checking Acct Public Funds

Account number	Beginning balance	Total credits	Total debits	Ending balance
4943186197	\$67,369.70	\$838,420.69	-\$666,261.51	\$239,528.88

Credits

Electronic deposits/bank credits

Effective date	Posted date	Amount	Transaction detail
	04/11	328,477.90	WT Seq456636 City of Coachella, Gene /Org=City of Coachella Srf# Gb00000057726463 Trn#230411456636 Rfb# 421
	04/18	4,752.16	eDeposit IN Branch/Store 04/18/23 09:48:31 Am 49201 Grapefruit Blvd Coachella CA
	04/25	505,190.63	WT Seq456775 City of Coachella, Gene /Org=City of Coachella Srf# Gb00000058020993 Trn#230425456775 Rfb# 423
		\$838,420.69	Total electronic deposits/bank credits
		\$838,420.69	Total credits

Debits

Electronic debits/bank debits

Effective date	Posted date	Amount	Transaction detail
	04/11	209,616.96	ACH Prep Origintn - City of Coachell - File 4956000693 Coid 5956000693
	04/14	509.26 <	Business to Business ACH Debit - Missionsquare Investment 230413 302310 230412 City of Coachella
	04/14	2,039.28 <	Business to Business ACH Debit - Employment Devel EDD Eftpmt 041323 1361605536 City of Coachella
	04/14	6,015.00	Nationwide Payments 230414 Dcd0009431500 City of Coachella
	04/14	10,901.32 <	Business to Business ACH Debit - Employment Devel EDD Eftpmt 041323 xxxxx8272 City of Coachella
	04/14	35,884.88 <	Business to Business ACH Debit - IRS Usatxpymt 041423 270350474728850 City of Coachella
	04/18	47.12 <	Business to Business ACH Debit - Calpers 3100 6373819375 100000017111002



EQUIPMENT FINANCING

Great rates for the equipment you need

Learn more at www.MechanicsBank.com/GetEquipment



PUBLIC INTEREST CHECKING-XXXXXXXX1679

Account Summary

Date	Description	Amount	Interest Summary	Amount
04/01/2023	Beginning Balance	\$4,880.92	Annual Percentage Yield Earned	0.00%
	0 Credit(s) This Period	\$0.00	Interest Days	0
	2 Debit(s) This Period	\$4,880.92	Interest Earned	\$0.00
04/18/2023	Ending Balance	\$0.00	Interest Paid This Period	\$0.00
			Interest Paid Year-to-Date	\$0.13

Other Debits

Date	Description	Amount
04/10/2023	Analysis Charges March 2023	\$118.76
04/17/2023	CLOSING WITHDRAWAL	\$4,762.16

Daily Balances

Date	Amount	Date	Amount
04/10/2023	\$4,762.16	04/17/2023	\$0.00

Overdraft and Returned Item Fees

	Total for this period	Total year-to-date
Total Overdraft Fees	\$0.00	\$0.00
Total Returned Item Fees	\$0.00	\$0.00



California State Treasurer Fiona Ma, CPA



Local Agency Investment Fund
P.O. Box 942809
Sacramento, CA 94209-0001
(916) 653-3001

May 02, 2023

[LAIF Home](#)
[PMIA Average Monthly Yields](#)

AB3107 S/A CITY OF COACHELLA FOR

COACHELLA RDA 1998 TAB
FINANCE DIRECTOR
1515 6TH STREET
COACHELLA, CA 92236

Acct#	Beg Bal	Interest	End Bal
11-33-001	126.45	0.85	127.30
65-33-004	2,529.66	17.05	2,546.71
70-33-001	-	-	-
98-33-171	18,092,725.80	121,942.05	18,214,667.85
		121,959.95	18,217,341.86

Account Number: 11-33-001

Apr 2023 Statement

[Tran Type Definitions](#)

<u>Effective Date</u>	<u>Transaction Date</u>	<u>Trans Type</u>	<u>Confirm Number</u>	<u>Web Confirm Number</u>	<u>Bond ID</u>	<u>Auth. Caller</u>	<u>Amount</u>
4/14/2023	4/13/2023	QBD	1725997	N/A		SYSTEM	0.85

Account Summary

Total Deposit: **0.85**
Total Withdrawal: 0.00

Beginning Balances

Principal: 0.00
Interest: 126.45

Ending Balances

Principal: 0.00
Interest: 127.30
Grand Total: 127.30

Bond ID	Bond Name	Principal Balance	Next Maturity Date
9201031	1990 PROJECT AREA #4	0.00	1/1/2012
9201032	1991 PROJECT AREA #3	0.00	1/31/2012
9812231	1998 TAX ALLOCATION REFUNDING, AREA #3	0.00	1/31/2012

California State Treasurer
Fiona Ma, CPA



Local Agency Investment Fund
 P.O. Box 942809
 Sacramento, CA 94209-0001
 (916) 653-3001

May 02, 2023

[LAIF Home](#)
[PMIA Average Monthly Yields](#)

S/A CITY OF COACHELLA FOR
 COACHELLA REDEVELOPMENT AGENCY
 FINANCE DIRECTOR
 1515 6TH STREET
 COACHELLA, CA 92236

[Tran Type Definitions](#)

Account Number: 65-33-004

April 2023 Statement

Effective Date	Transaction Date	Tran Type	Confirm Number	Web Confirm Number	Authorized Caller	Amount
4/14/2023	4/13/2023	QRD	1726961	N/A	SYSTEM	17.05

Account Summary

Total Deposit:	17.05	Beginning Balance:	2,529.66
Total Withdrawal:	0.00	Ending Balance:	2,546.71

California State Treasurer
Fiona Ma, CPA



Local Agency Investment Fund
 P.O. Box 942809
 Sacramento, CA 94209-0001
 (916) 653-3001

May 02, 2023

[LAIF Home](#)
[PMIA Average Monthly Yields](#)

CITY OF COACHELLA

FINANCE DIRECTOR
 1515 SIXTH STREET
 COACHELLA, CA 92236

[Tran Type Definitions](#)

Account Number: 98-33-171

April 2023 Statement

Effective Date	Transaction Date	Tran Type	Confirm Number	Web Confirm Number	Authorized Caller	Amount
4/14/2023	4/13/2023	QRD	1728007	N/A	SYSTEM	121,942.05

Account Summary

Total Deposit:	121,942.05	Beginning Balance:	18,092,725.80
Total Withdrawal:	0.00	Ending Balance:	18,214,667.85

00218301
22- -01-B -82 -124-01
0102 -11-04304-01



CITY OF COACHELLA
ACCOUNT 291144545

Page 5 of 42
Period from April 1, 2023 to April 30, 2023

ASSET SUMMARY

ASSETS	04/30/2023 MARKET VALUE	% OF MARKET
Cash And Equivalents	456,117.30	1.35
U.S. Government Issues	26,937,314.79	79.68
Corporate Issues	5,097,616.09	15.08
Foreign Issues	430,197.00	1.27
Municipal Issues	752,243.60	2.23
Total Assets	33,673,488.78	99.61
Accrued Income	131,621.13	0.39
Grand Total	33,805,109.91	100.00

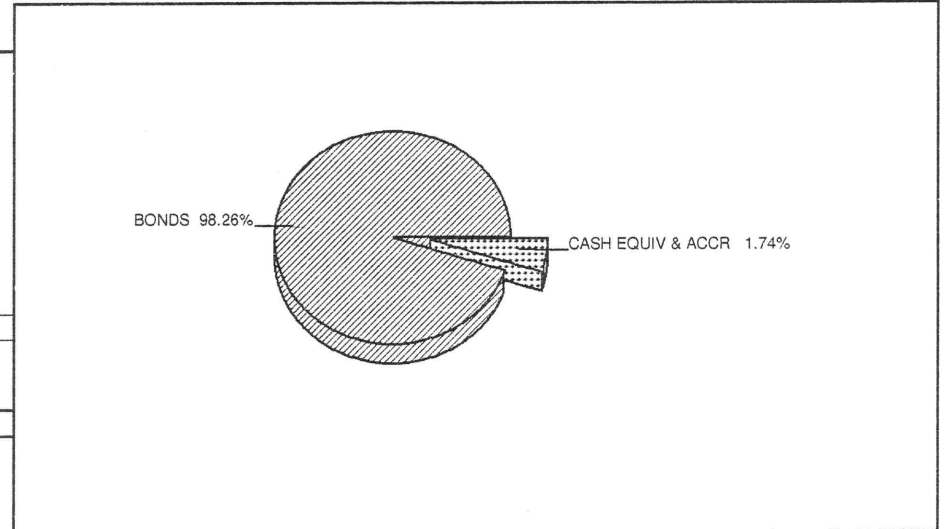



ACCOUNT NUMBER: 6712104701
SUCCESSOR AGENCY TO THE COACHELLA
REDEVELOPMENT AGENCY SUBORDINATE
TAX ALLOCATION BONDS (MERGED PROJECT
PROJECT AREAS) 2014 SERIES
DEBT SERVICE FUND

This statement is for the period from
April 1, 2023 to **April 30, 2023**

MARKET VALUE SUMMARY

	Current Period 04/01/23 to 04/30/23
Beginning Market Value	\$765.63
Investment Results	
Interest, Dividends and Other Income	2.87
Total Investment Results	\$2.87
Ending Market Value	\$768.50





ACCOUNT NUMBER: 6712104702
SUCCESSOR AGENCY TO THE COACHELLA
REDEVELOPMENT AGENCY SUBORDINATE
TAX ALLOCATION BONDS (MERGED PROJECT
PROJECT AREAS) 2014 SERIES
INTEREST ACCOUNT

This statement is for the period from
April 1, 2023 to **April 30, 2023**

MARKET VALUE SUMMARY

Current Period
04/01/23 to 04/30/23

Beginning Market Value	\$0.00
-------------------------------	---------------

Ending Market Value	\$0.00
----------------------------	---------------

MARKET VALUE SUMMARY MESSAGES

No activity qualifies for this statement period.





ACCOUNT NUMBER: 6712104703
SUCCESSOR AGENCY TO THE COACHELLA
REDEVELOPMENT AGENCY SUBORDINATE
TAX ALLOCATION BONDS (MERGED PROJECT
PROJECT AREAS) 2014 SERIES
PRINCIPAL ACCOUNT

This statement is for the period from
April 1, 2023 to **April 30, 2023**

MARKET VALUE SUMMARY

Current Period
04/01/23 to 04/30/23

Beginning Market Value	\$0.00
-------------------------------	---------------

Ending Market Value	\$0.00
----------------------------	---------------

MARKET VALUE SUMMARY MESSAGES

No activity qualifies for this statement period.





ACCOUNT NUMBER: 6712104704
SUCCESSOR AGENCY TO THE COACHELLA
REDEVELOPMENT AGENCY SUBORDINATE
TAX ALLOCATION BONDS (MERGED PROJECT
PROJECT AREAS) 2014 SERIES
RESERVE ACCOUNT

This statement is for the period from
April 1, 2023 to **April 30, 2023**

MARKET VALUE SUMMARY

Current Period
04/01/23 to 04/30/23

Beginning Market Value	\$827,612.50
-------------------------------	---------------------

Ending Market Value	\$827,612.50
----------------------------	---------------------

MARKET VALUE SUMMARY MESSAGES

No activity qualifies for this statement period.





ACCOUNT NUMBER: 6712148601
COACHELLA SANITARY DISTRICT
WASTEWATER REVENUE REFUNDING BONDS,
SERIES 2015A
BOND FUND

This statement is for the period from
April 1, 2023 to **April 30, 2023**

MARKET VALUE SUMMARY

	Current Period 04/01/23 to 04/30/23
Beginning Market Value	\$178.71
Contributions	157.96
Adjusted Market Value	\$336.67
Investment Results	
Interest, Dividends and Other Income	783.21
Total Investment Results	\$783.21
Ending Market Value	\$1,119.88





ACCOUNT NUMBER: 6712148602
COACHELLA SANITARY DISTRICT
WASTEWATER REVENUE REFUNDING BONDS,
SERIES 2015A
INTEREST ACCOUNT OF BOND FUND

This statement is for the period from
April 1, 2023 to **April 30, 2023**

MARKET VALUE SUMMARY

	Current Period 04/01/23 to 04/30/23
Beginning Market Value	\$60,712.51
Distributions	- 60,751.54
Adjusted Market Value	- \$39.03
Investment Results	
Interest, Dividends and Other Income	39.03
Total Investment Results	\$39.03
Ending Market Value	\$0.00





ACCOUNT NUMBER: 6712148603
COACHELLA SANITARY DISTRICT
WASTEWATER REVENUE REFUNDING BONDS,
SERIES 2015A
PRINCIPAL ACCOUNT OF BOND FUND

This statement is for the period from
April 1, 2023 to **April 30, 2023**

MARKET VALUE SUMMARY

	Current Period 04/01/23 to 04/30/23
Beginning Market Value	\$185,000.00
Distributions	- 185,118.93
Adjusted Market Value	- \$118.93
Investment Results	
Interest, Dividends and Other Income	118.93
Total Investment Results	\$118.93
Ending Market Value	\$0.00





ACCOUNT NUMBER: 6712148604
COACHELLA SANITARY DISTRICT
WASTEWATER REVENUE REFUNDING BONDS,
SERIES 2015A
RESERVE ACCOUNT OF BOND FUND

This statement is for the period from
April 1, 2023 to **April 30, 2023**

MARKET VALUE SUMMARY

Current Period
04/01/23 to 04/30/23

Beginning Market Value	\$310,175.00
-------------------------------	---------------------

Ending Market Value	\$310,175.00
----------------------------	---------------------

MARKET VALUE SUMMARY MESSAGES

No activity qualifies for this statement period.





ACCOUNT NUMBER: 6711963500
COACHELLA SANITARY DISTRICT CUSTODY
ACCOUNT FOR PROJECT FUND 2011

This statement is for the period from
April 1, 2023 to **April 30, 2023**

MARKET VALUE SUMMARY

	Current Period 04/01/23 to 04/30/23
Beginning Market Value	\$25,828.44
Investment Results	
Interest, Dividends and Other Income	98.85
Total Investment Results	\$98.85
Ending Market Value	\$25,927.29





ACCOUNT NUMBER: 6712071401
SUCCESSOR AGENCY TO THE COACHELLA
REDEVELOPMENT AGENCY SUBORDINATE TAX
ALLOCATION BONDS (MERGED PROJECT
AREAS) SERIES 2013
DEBT SERVICE FUND

This statement is for the period from
April 1, 2023 to **April 30, 2023**

MARKET VALUE SUMMARY

	Current Period 04/01/23 to 04/30/23
Beginning Market Value	\$233.61
Investment Results	
Interest, Dividends and Other Income	0.88
Total Investment Results	\$0.88
Ending Market Value	\$234.49





ACCOUNT NUMBER: 6712071402
SUCCESSOR AGENCY TO THE COACHELLA
REDEVELOPMENT AGENCY SUBORDINATE TAX
ALLOCATION BONDS (MERGED PROJECT
AREAS) SERIES 2013
INTEREST ACCOUNT

This statement is for the period from
April 1, 2023 to **April 30, 2023**

MARKET VALUE SUMMARY

Current Period
04/01/23 to 04/30/23

Beginning Market Value	\$0.00
-------------------------------	---------------

Ending Market Value	\$0.00
----------------------------	---------------

MARKET VALUE SUMMARY MESSAGES

No activity qualifies for this statement period.





ACCOUNT NUMBER: 6712071403
SUCCESSOR AGENCY TO THE COACHELLA
REDEVELOPMENT AGENCY SUBORDINATE TAX
ALLOCATION BONDS (MERGED PROJECT
AREAS) SERIES 2013
PRINCIPAL ACCOUNT

This statement is for the period from
April 1, 2023 to **April 30, 2023**

MARKET VALUE SUMMARY

Current Period
04/01/23 to 04/30/23

Beginning Market Value	\$0.00
-------------------------------	---------------

Ending Market Value	\$0.00
----------------------------	---------------

MARKET VALUE SUMMARY MESSAGES

No activity qualifies for this statement period.





ACCOUNT NUMBER: 6712071404
SUCCESSOR AGENCY TO THE COACHELLA
REDEVELOPMENT AGENCY SUBORDINATE TAX
ALLOCATION BONDS (MERGED PROJECT
AREAS) SERIES 2013
RESERVE ACCOUNT

This statement is for the period from
April 1, 2023 to **April 30, 2023**

MARKET VALUE SUMMARY

Current Period
04/01/23 to 04/30/23

Beginning Market Value	\$406,487.50
-------------------------------	---------------------

Ending Market Value	\$406,487.50
----------------------------	---------------------

MARKET VALUE SUMMARY MESSAGES

No activity qualifies for this statement period.





ACCOUNT NUMBER: 6712160601
SUCCESSOR AGENCY TO COACHELLA
RDA TAX ALLOCATION REFUNDING BONDS
SERIES 2016A & 2016B
DEBT SERVICE FUND

This statement is for the period from
April 1, 2023 to **April 30, 2023**

MARKET VALUE SUMMARY

	Current Period 04/01/23 to 04/30/23
Beginning Market Value	\$1,972.26
Investment Results	
Interest, Dividends and Other Income	7.41
Total Investment Results	\$7.41
Ending Market Value	\$1,979.67





ACCOUNT NUMBER: 6712160602
SUCCESSOR AGENCY TO COACHELLA
RDA TAX ALLOCATION REFUNDING BONDS
SERIES 2016A & 2016B
INTEREST ACCOUNT

This statement is for the period from
April 1, 2023 to **April 30, 2023**

MARKET VALUE SUMMARY

Current Period
04/01/23 to 04/30/23

Beginning Market Value	\$0.00
-------------------------------	---------------

Ending Market Value	\$0.00
----------------------------	---------------

MARKET VALUE SUMMARY MESSAGES

No activity qualifies for this statement period.





ACCOUNT NUMBER: 6712160603
SUCCESSOR AGENCY TO COACHELLA
RDA TAX ALLOCATION REFUNDING BONDS
SERIES 2016A & 2016B
PRINCIPAL ACCOUNT

This statement is for the period from
April 1, 2023 to **April 30, 2023**

MARKET VALUE SUMMARY

Current Period
04/01/23 to 04/30/23

Beginning Market Value	\$0.00
-------------------------------	---------------

Ending Market Value	\$0.00
----------------------------	---------------

MARKET VALUE SUMMARY MESSAGES

No activity qualifies for this statement period.





ACCOUNT NUMBER: 6712179801
COACHELLA FINANCING AUTHORITY
LEASE REVENUE BONDS, SERIES 2016
PAYMENT FUND

This statement is for the period from
April 1, 2023 to **April 30, 2023**

MARKET VALUE SUMMARY

	Current Period 04/01/23 to 04/30/23
Beginning Market Value	\$481.55
Investment Results	
Interest, Dividends and Other Income	1.72
Total Investment Results	\$1.72
Ending Market Value	\$483.27





ACCOUNT NUMBER: 6712179802
COACHELLA FINANCING AUTHORITY
LEASE REVENUE BONDS, SERIES 2016
INTEREST ACCOUNT OF PAYMENT FUND

This statement is for the period from
April 1, 2023 to **April 30, 2023**

MARKET VALUE SUMMARY

Current Period
04/01/23 to 04/30/23

Beginning Market Value	\$0.00
-------------------------------	---------------

Ending Market Value	\$0.00
----------------------------	---------------

MARKET VALUE SUMMARY MESSAGES

No activity qualifies for this statement period.





ACCOUNT NUMBER: 6712179803
COACHELLA FINANCING AUTHORITY
LEASE REVENUE BONDS, SERIES 2016
PRINCIPAL ACCOUNT OF PAYMENT FUND

This statement is for the period from
April 1, 2023 to April 30, 2023

MARKET VALUE SUMMARY

Current Period
04/01/23 to 04/30/23

Beginning Market Value	\$0.00
-------------------------------	---------------

Ending Market Value	\$0.00
----------------------------	---------------

MARKET VALUE SUMMARY MESSAGES

No activity qualifies for this statement period.





ACCOUNT NUMBER: 6712179804
COACHELLA FINANCING AUTHORITY
LEASE REVENUE BONDS, SERIES 2016
COMMON RESERVE ACCOUNT

This statement is for the period from
April 1, 2023 to **April 30, 2023**

MARKET VALUE SUMMARY

Current Period
04/01/23 to 04/30/23

Beginning Market Value	\$612,331.26
-------------------------------	---------------------

Ending Market Value	\$612,331.26
----------------------------	---------------------

MARKET VALUE SUMMARY MESSAGES

No activity qualifies for this statement period.



STATEMENT OF TRANSACTIONS
FOR THE PERIOD APRIL 1, 2023 THROUGH APRIL 30, 2023

CITY OF COACHELLA SER19 DEBT SERV FD
ACCOUNT NUMBER 83925300

STATEMENT OF TRANSACTIONS

<u>DATE</u>	<u>PAR VALUE/SHARES</u>	<u>DESCRIPTION</u>	<u>PRINCIPAL CASH</u>	<u>INCOME CASH</u>	<u>COST VALUE</u>	<u>REALIZED GAIN/LOSS</u>
		<u>BEGINNING BALANCE</u>	<u>0.00</u>	<u>0.00</u>	<u>171.08</u>	
04/03/23		TRANSFER TO PRINCIPAL TRANSFER INCOME TO PRINCIPAL		0.60-		
04/03/23		ADDITION TO ACCOUNT TRANSFER FROM INCOME TRANSFER INCOME TO PRINCIPAL	0.60			
04/03/23		INTEREST RECEIVED ALLSPRING GOVERNMENT MM FD-SVC #743 INTEREST FROM 3/1/23 TO 3/31/23		0.60		
04/30/23	1.2	CASH SWEEP PURCHASES FOR STMT PERIOD ALLSPRING GOVERNMENT MM FD-SVC #743 2 TRANSACTIONS	1.20-		1.20	
04/30/23	0.6-	CASH SWEEP SALES FOR STMT PERIOD ALLSPRING GOVERNMENT MM FD-SVC #743 1 TRANSACTION	0.60		0.60-	
		<u>ENDING BALANCE</u>	<u>0.00</u>	<u>0.00</u>	<u>171.68</u>	

STATEMENT OF TRANSACTIONS
FOR THE PERIOD APRIL 1, 2023 THROUGH APRIL 30, 2023

CITY OF COACHELLA SER19 INTEREST ACC
ACCOUNT NUMBER 83925301

STATEMENT OF TRANSACTIONS

<u>DATE</u>	<u>PAR VALUE/SHARES</u>	<u>DESCRIPTION</u>	<u>PRINCIPAL CASH</u>	<u>INCOME CASH</u>	<u>COST VALUE</u>	<u>REALIZED GAIN/LOSS</u>
		<u>BEGINNING BALANCE</u>	<u>0.00</u>	<u>0.00</u>	<u>7.62</u>	
04/03/23		TRANSFER TO PRINCIPAL TRANSFER INCOME TO PRINCIPAL		0.03-		
04/03/23		ADDITION TO ACCOUNT TRANSFER FROM INCOME TRANSFER INCOME TO PRINCIPAL	0.03			
04/03/23		INTEREST RECEIVED ALLSPRING GOVERNMENT MM FD-SVC #743 INTEREST FROM 3/1/23 TO 3/31/23		0.03		
04/30/23	0.06	CASH SWEEP PURCHASES FOR STMT PERIOD ALLSPRING GOVERNMENT MM FD-SVC #743 2 TRANSACTIONS	0.06-		0.06	
04/30/23	0.03-	CASH SWEEP SALES FOR STMT PERIOD ALLSPRING GOVERNMENT MM FD-SVC #743 1 TRANSACTION	0.03		0.03-	
		<u>ENDING BALANCE</u>	<u>0.00</u>	<u>0.00</u>	<u>7.65</u>	

STATEMENT OF TRANSACTIONS
FOR THE PERIOD APRIL 1, 2023 THROUGH APRIL 30, 2023

CITY OF COACHELLA SER19 PRIN ACCT
ACCOUNT NUMBER 83925302

STATEMENT OF TRANSACTIONS

<u>DATE</u>	<u>PAR VALUE/SHARES</u>	<u>DESCRIPTION</u>	<u>PRINCIPAL CASH</u>	<u>INCOME CASH</u>	<u>COST VALUE</u>	<u>REALIZED GAIN/LOSS</u>
		<u>BEGINNING BALANCE</u>	<u>0.00</u>	<u>0.00</u>	<u>17.90</u>	
04/03/23		TRANSFER TO PRINCIPAL TRANSFER INCOME TO PRINCIPAL		0.06-		
04/03/23		ADDITION TO ACCOUNT TRANSFER FROM INCOME TRANSFER INCOME TO PRINCIPAL	0.06			
04/03/23		INTEREST RECEIVED ALLSPRING GOVERNMENT MM FD-SVC #743 INTEREST FROM 3/1/23 TO 3/31/23		0.06		
04/30/23	0.12	CASH SWEEP PURCHASES FOR STMT PERIOD ALLSPRING GOVERNMENT MM FD-SVC #743 2 TRANSACTIONS	0.12-		0.12	
04/30/23	0.06-	CASH SWEEP SALES FOR STMT PERIOD ALLSPRING GOVERNMENT MM FD-SVC #743 1 TRANSACTION	0.06		0.06-	
		<u>ENDING BALANCE</u>	<u>0.00</u>	<u>0.00</u>	<u>17.96</u>	

Portfolio Valuations & Activity Summary

Category	Current Period	Year-to-Date
Opening Market Value	\$102.77	\$191,104.40
Accrued Income	0.31	61.29
Opening Market Value w/Accrued Income	\$103.08	\$191,165.69
Contributions		
Cash Receipts	-	-
Intra-Account Transfers	-	-
Other Receipts	0.31	103.08
Securities Transferred In	-	-
Tax Refunds	-	-
Total Contributions	\$0.31	\$103.08
Withdrawals		
Cash Disbursements	-0.31	-191,207.48
Intra-Account Transfers	-	-
Other Disbursements	-	-
Other Fees	-	-
Securities Transferred Out	-	-
Tax Payments	-	-
Taxes Withheld	-	-
Wilmington Trust Fees	-	-
Total Withdrawals	-\$0.31	-\$191,207.48
Net Contributions & Withdrawals	-	-\$191,104.40
Closing Market Value	103.08	103.08
Accrued Income	0.30	0.30
Closing Market Value w/Accrued Income	\$103.38	\$103.38
Net Investment Change	\$0.30	\$42.09

Net Investment Change Detail

	Current Period	Year-to-Date
Net Investment Change	\$0.30	\$42.09
Income Earned		
Dividends	0.31	103.08
Net Interest	-	-
Other Income	-	-
Change in Accrual	-0.01	-60.99
Total Income Earned	\$0.30	\$42.09
Market Appreciation	-	-

Management and advisory fees charged through accounts not listed under the Market Value Summary will not be shown in this schedule. Transactions classified in Other (Receipts, Fees, and Disbursements) categories are identified in the Transaction Activity Detail.

Market Appreciation reflects your Closing Market Value w/Accrued Income, less the net of contributions, withdrawals, and income earned, less your Opening Market Value w/Accrued Income.

Portfolio Valuations & Activity Summary

Category	Current Period	Year-to-Date
Opening Market Value	\$11,237.20	\$10,498.88
Accrued Income	40.61	31.48
Opening Market Value w/Accrued Income	\$11,277.81	\$10,530.36
Contributions		
Cash Receipts	-	86,601.12
Intra-Account Transfers	4,241.97	15,479.17
Other Receipts	-	-
Securities Transferred In	-	-
Tax Refunds	-	-
Total Contributions	\$4,241.97	\$102,080.29
Withdrawals		
Cash Disbursements	-	-97,100.00
Intra-Account Transfers	-40.61	-318.63
Other Disbursements	-	-
Other Fees	-	-
Securities Transferred Out	-	-
Tax Payments	-	-
Taxes Withheld	-	-
Wilmington Trust Fees	-	-
Total Withdrawals	-\$40.61	-\$97,418.63
Net Contributions & Withdrawals	\$4,201.36	\$4,661.66
Closing Market Value	15,479.17	15,479.17
Accrued Income	55.35	55.35
Closing Market Value w/Accrued Income	\$15,534.52	\$15,534.52
Net Investment Change	\$55.35	\$342.50

Net Investment Change Detail

	Current Period	Year-to-Date
Net Investment Change	\$55.35	\$342.50
Income Earned		
Dividends	40.61	318.63
Net Interest	-	-
Other Income	-	-
Change in Accrual	14.74	23.87
Total Income Earned	\$55.35	\$342.50
Market Appreciation	-	-

Management and advisory fees charged through accounts not listed under the Market Value Summary will not be shown in this schedule. Transactions classified in Other (Receipts, Fees, and Disbursements) categories are identified in the Transaction Activity Detail.

Market Appreciation reflects your Closing Market Value w/Accrued Income, less the net of contributions, withdrawals, and income earned, less your Opening Market Value w/Accrued Income.

Portfolio Valuations & Activity Summary

Category	Current Period	Year-to-Date
Opening Market Value	-	-
Accrued Income	-	-
Opening Market Value w/Accrued Income	-	-
Contributions		
Cash Receipts	-	95,100.00
Intra-Account Transfers	-	-
Other Receipts	-	-
Securities Transferred In	-	-
Tax Refunds	-	-
Total Contributions	-	\$95,100.00
Withdrawals		
Cash Disbursements	-	-95,100.00
Intra-Account Transfers	-	-59.64
Other Disbursements	-	-
Other Fees	-	-
Securities Transferred Out	-	-
Tax Payments	-	-
Taxes Withheld	-	-
Wilmington Trust Fees	-	-
Total Withdrawals	-	-\$95,159.64
Net Contributions & Withdrawals	-	-\$59.64
Closing Market Value	-	-
Accrued Income	-	-
Closing Market Value w/Accrued Income	-	-
Net Investment Change	-	\$59.64
Net Investment Change Detail		
	Current Period	Year-to-Date
Net Investment Change	-	\$59.64
Income Earned		
Dividends	-	59.64
Net Interest	-	-
Other Income	-	-
Change in Accrual	-	-
Total Income Earned	-	\$59.64
Market Appreciation	-	-

Management and advisory fees charged through accounts not listed under the Market Value Summary will not be shown in this schedule. Transactions classified in Other (Receipts, Fees, and Disbursements) categories are identified in the Transaction Activity Detail.

Market Appreciation reflects your Closing Market Value w/Accrued Income, less the net of contributions, withdrawals, and income earned, less your Opening Market Value w/Accrued Income.

Portfolio Valuations & Activity Summary

Category	Current Period	Year-to-Date
Opening Market Value	-	-
Accrued Income	-	-
Opening Market Value w/Accrued Income	-	-
Contributions		
Cash Receipts	-	-
Intra-Account Transfers	-	-
Other Receipts	-	-
Securities Transferred In	-	-
Tax Refunds	-	-
Total Contributions	-	-
Withdrawals		
Cash Disbursements	-	-
Intra-Account Transfers	-	-
Other Disbursements	-	-
Other Fees	-	-
Securities Transferred Out	-	-
Tax Payments	-	-
Taxes Withheld	-	-
Wilmington Trust Fees	-	-
Total Withdrawals	-	-
Net Contributions & Withdrawals	-	-
Closing Market Value	-	-
Accrued Income	-	-
Closing Market Value w/Accrued Income	-	-
Net Investment Change	-	-

Net Investment Change Detail

Category	Current Period	Year-to-Date
Net Investment Change	-	-
Income Earned		
Dividends	-	-
Net Interest	-	-
Other Income	-	-
Change in Accrual	-	-
Total Income Earned	-	-
Market Appreciation	-	-

Management and advisory fees charged through accounts not listed under the Market Value Summary will not be shown in this schedule. Transactions classified in Other (Receipts, Fees, and Disbursements) categories are identified in the Transaction Activity Detail.

Market Appreciation reflects your Closing Market Value w/Accrued Income, less the net of contributions, withdrawals, and income earned, less your Opening Market Value w/Accrued Income.

Portfolio Valuations & Activity Summary

Category	Current Period	Year-to-Date
Opening Market Value	\$1,158,118.37	\$1,158,118.37
Accrued Income	4,201.36	3,507.10
Opening Market Value w/Accrued Income	\$1,162,319.73	\$1,161,625.47
Contributions		
Cash Receipts	-	-
Intra-Account Transfers	-	-
Other Receipts	-	-
Securities Transferred In	-	-
Tax Refunds	-	-
Total Contributions	-	-
Withdrawals		
Cash Disbursements	-	-
Intra-Account Transfers	-4,201.36	-15,100.90
Other Disbursements	-	-
Other Fees	-	-
Securities Transferred Out	-	-
Tax Payments	-	-
Taxes Withheld	-	-
Wilmington Trust Fees	-	-
Total Withdrawals	-\$4,201.36	-\$15,100.90
Net Contributions & Withdrawals	-\$4,201.36	-\$15,100.90
Closing Market Value	1,158,118.37	1,158,118.37
Accrued Income	4,259.68	4,259.68
Closing Market Value w/Accrued Income	\$1,162,378.05	\$1,162,378.05
Net Investment Change	\$4,259.68	\$15,853.48
Net Investment Change Detail		
Net Investment Change	\$4,259.68	\$15,853.48
Income Earned		
Dividends	4,201.36	15,100.90
Net Interest	-	-
Other Income	-	-
Change in Accrual	58.32	752.58
Total Income Earned	\$4,259.68	\$15,853.48
Market Appreciation	-	-

Management and advisory fees charged through accounts not listed under the Market Value Summary will not be shown in this schedule. Transactions classified in Other (Receipts, Fees, and Disbursements) categories are identified in the Transaction Activity Detail.

Market Appreciation reflects your Closing Market Value w/Accrued Income, less the net of contributions, withdrawals, and income earned, less your Opening Market Value w/Accrued Income.

Portfolio Valuations & Activity Summary

Category	Current Period	Year-to-Date
Opening Market Value	\$323.32	\$112.97
Accrued Income	1.24	0.31
Opening Market Value w/Accrued Income	\$324.56	\$113.28
Contributions		
Cash Receipts	-	114,087.03
Intra-Account Transfers	1.24	324.56
Other Receipts	-	-
Securities Transferred In	-	-
Tax Refunds	-	-
Total Contributions	\$1.24	\$114,411.59
Withdrawals		
Cash Disbursements	-	-114,200.00
Intra-Account Transfers	-1.24	-252.93
Other Disbursements	-	-
Other Fees	-	-
Securities Transferred Out	-	-
Tax Payments	-	-
Taxes Withheld	-	-
Wilmington Trust Fees	-	-
Total Withdrawals	-\$1.24	-\$114,452.93
Net Contributions & Withdrawals	-	-\$41.34
Closing Market Value	324.56	324.56
Accrued Income	1.20	1.20
Closing Market Value w/Accrued Income	\$325.76	\$325.76
Net Investment Change	\$1.20	\$253.82

Net Investment Change Detail

	Current Period	Year-to-Date
Net Investment Change	\$1.20	\$253.82
Income Earned		
Dividends	1.24	252.93
Net Interest	-	-
Other Income	-	-
Change in Accrual	-0.04	0.89
Total Income Earned	\$1.20	\$253.82
Market Appreciation	-	-

Management and advisory fees charged through accounts not listed under the Market Value Summary will not be shown in this schedule. Transactions classified in Other (Receipts, Fees, and Disbursements) categories are identified in the Transaction Activity Detail.

Market Appreciation reflects your Closing Market Value w/Accrued Income, less the net of contributions, withdrawals, and income earned, less your Opening Market Value w/Accrued Income.

Portfolio Valuations & Activity Summary

Category	Current Period	Year-to-Date
Opening Market Value	-	-
Accrued Income	-	-
Opening Market Value w/Accrued Income	-	-
Contributions		
Cash Receipts	-	-
Intra-Account Transfers	-	-
Other Receipts	-	-
Securities Transferred In	-	-
Tax Refunds	-	-
Total Contributions	-	-
Withdrawals		
Cash Disbursements	-	-
Intra-Account Transfers	-	-
Other Disbursements	-	-
Other Fees	-	-
Securities Transferred Out	-	-
Tax Payments	-	-
Taxes Withheld	-	-
Wilmington Trust Fees	-	-
Total Withdrawals	-	-
Net Contributions & Withdrawals	-	-
Closing Market Value	-	-
Accrued Income	-	-
Closing Market Value w/Accrued Income	-	-
Net Investment Change	-	-
Net Investment Change Detail		
Net Investment Change	-	-
Income Earned		
Dividends	-	-
Net Interest	-	-
Other Income	-	-
Change in Accrual	-	-
Total Income Earned	-	-
Market Appreciation	-	-

Management and advisory fees charged through accounts not listed under the Market Value Summary will not be shown in this schedule. Transactions classified in Other (Receipts, Fees, and Disbursements) categories are identified in the Transaction Activity Detail.

Market Appreciation reflects your Closing Market Value w/Accrued Income, less the net of contributions, withdrawals, and income earned, less your Opening Market Value w/Accrued Income.

Portfolio Valuations & Activity Summary

Category	Current Period	Year-to-Date
Opening Market Value	-	-
Accrued Income	-	-
Opening Market Value w/Accrued Income	-	-
Contributions		
Cash Receipts	-	114,200.00
Intra-Account Transfers	-	-
Other Receipts	-	-
Securities Transferred In	-	-
Tax Refunds	-	-
Total Contributions	-	\$114,200.00
Withdrawals		
Cash Disbursements	-	-114,200.00
Intra-Account Transfers	-	-71.63
Other Disbursements	-	-
Other Fees	-	-
Securities Transferred Out	-	-
Tax Payments	-	-
Taxes Withheld	-	-
Wilmington Trust Fees	-	-
Total Withdrawals	-	-\$114,271.63
Net Contributions & Withdrawals	-	-\$71.63
Closing Market Value	-	-
Accrued Income	-	-
Closing Market Value w/Accrued Income	-	-
Net Investment Change	-	\$71.63
Net Investment Change Detail		
Net Investment Change	-	\$71.63
Income Earned		
Dividends	-	71.63
Net Interest	-	-
Other Income	-	-
Change in Accrual	-	-
Total Income Earned	-	\$71.63
Market Appreciation	-	-

Management and advisory fees charged through accounts not listed under the Market Value Summary will not be shown in this schedule. Transactions classified in Other (Receipts, Fees, and Disbursements) categories are identified in the Transaction Activity Detail.

Market Appreciation reflects your Closing Market Value w/Accrued Income, less the net of contributions, withdrawals, and income earned, less your Opening Market Value w/Accrued Income.